

# 1997 Civic Coupe Online Reference Owner's Manual

Use these links (and links throughout this manual) to navigate through this reference.

For a printed owner's manual, click on authorized manuals or go to [www.helminc.com](http://www.helminc.com).

## Contents

---

### Owner's Identification

<b>Introduction</b> .....	<b>i</b>
<b>A Few Words About Safety</b> .....	<b>ii</b>
<b>Driver and Passenger Safety</b> .....	<b>3</b>
Proper use and care of your vehicle's seat belts, and Supplemental Restraint System.	
<b>Instruments and Controls</b> .....	<b>31</b>
Instrument panel indicator and gauge, and how to use dashboard and steering column controls.	
<b>Comfort and Convenience Features</b> .....	<b>67</b>
How to operate the climate control system, the audio system, and other convenience features.	
<b>Before Driving</b> .....	<b>89</b>
What gasoline to use, how to break-in your new vehicle, and how to load luggage and other cargo.	
<b>Driving</b> .....	<b>99</b>
The proper way to start the engine, shift the transmission, and park, plus towing a trailer.	
<b>Maintenance</b> .....	<b>121</b>
The Maintenance Schedule shows you when you need to take your vehicle to the dealer.	
<b>Appearance Care</b> .....	<b>173</b>
Tips on cleaning and protecting your vehicle. Things to look for if your car ever needs body repairs.	
<b>Taking Care of the Unexpected</b> .....	<b>179</b>
This section covers several problems motorists sometimes experience, and how to handle them.	
<b>Technical Information</b> .....	<b>201</b>
ID numbers, dimensions, capacities, and technical information.	
<b>Warranty and Customer Relations (U.S. and Canada)</b> .....	<b>213</b>
A summary of the warranties covering your new Honda, and how to contact us.	
<b>Authorized Manuals (U.S. only)</b> .....	<b>219</b>
How to order manuals and other technical literature.	
<b>Index</b> .....	<b>I</b>

### Gas Station Information

A summary of information you need when you pull up to the fuel pump.

Congratulations ! Your selection of a 1997 Honda Civic was a wise investment. It will give you years of driving pleasure.

One of the best ways to enhance the enjoyment of your new Honda is to read this manual. In it, you will learn how to operate its driving controls and convenience items. Afterwards, keep this owner's manual in your vehicle so you can refer to it at any time.

Several warranties protect your new Honda. Read the warranty booklet thoroughly so you understand the coverages and are aware of your rights and responsibilities.

Maintaining your vehicle according to the schedules given in this manual helps to keep your driving trouble-free while it preserves your investment. When your vehicle needs maintenance, keep in mind that your Honda dealer's staff is specially trained in servicing the many systems unique to your Honda. Your Honda dealer is dedicated to your satisfaction and will be pleased to answer any questions and concerns.

As you read this manual, you will find information that is preceded by a **NOTICE** symbol. This information is intended to help you avoid damage to your Honda, other property, or the environment.

## A Few Words About Safety

---

Your safety, and the safety of others, is very important. And operating this vehicle safely is an important responsibility.

To help you make informed decisions about safety, we have provided operating procedures and other information on labels and in this manual.

This information alerts you to potential hazards that could hurt you or others.

Of course, it is not practical or possible to warn you about all the hazards associated with operating or maintaining your vehicle. You must use your own good judgement.

You will find important safety information in a variety of forms, including:

- **Safety Labels** — on the vehicle.
- **Safety Messages** — preceded by a safety alert symbol  and one of three signal words: **DANGER**, **WARNING**, or **CAUTION**.

These signal words mean:

You **WILL** be **KILLED** or **SERIOUSLY HURT** if you do not follow instructions.

You **CAN** be **KILLED** or **SERIOUSLY HURT** if you do not follow instructions.

You **CAN** be **HURT** if you do not follow instructions.

- **Safety Headings** — such as Important Safety Reminders or Important Safety Precautions.
- **Safety Section** — such as Driver and Passenger Safety.
- **Instructions** — how to use this vehicle correctly and safely.

This entire book is filled with important safety information — please read it carefully.

This section gives you important information about occupant protection. It shows how to use seat belts properly. It explains the Supplemental Restraint System. And it gives useful information about how to protect infants and children in your car.

Your Occupant Protection System..	4
The Seat Belt System and How It Works.....	5
Why Wear Seat Belts.....	5

Important Safety Reminders.....	5
Seat Belt System Components....	6
Lap/Shoulder Belt.....	6
Lap Belt.....	7
Wearing Seat Belts Properly.....	7
Wearing a Lap/Shoulder Belt.....	7
Wearing the Lap Belt.....	9
Advice for Pregnant Women.....	10
Seat Belt Maintenance.....	11
Supplemental Restraint System....	12
SRS Components.....	12
What Happens In a Crash.....	12
Important Facts About Airbags.....	13
How the Driver's Airbag Works.....	14
How the Passenger's Airbag Works.....	15
How the SRS Indicator Light Works.....	16
System Service.....	16
System Service Precautions.....	17
Additional Safety Information.....	18
Seat-back Position.....	18
Head Restraint Position.....	18
Door Locks.....	19

Storing Cargo Safely.....	19
Driving with Pets.....	19
Child Safety.....	20
Where Should Children Sit?.....	20
Important Safety Reminders.....	21
General Guidelines for Restraining Children Under 40 lbs (18 kg).....	22
Restraining an Infant Who Weighs Less Than 20 lbs (9 kg).....	22
Restraining a Child Who Weighs Between 20 and 40 lbs (9 and 18 kg)....	23
Restraining a Child Who Weighs Over 40 lbs (18 kg).....	24
Securing a Child Seat with a Lap/Shoulder Belt.....	24
Using Child Restraints with Tethers.....	25
Storing a Child Seat.....	26
Alcohol and Drugs.....	27
Carbon Monoxide Hazard.....	28
Safety Labels.....	29

# Your Occupant Protection System

---

Your Honda is equipped with seat belts and other features that work together to protect you and your passengers during a crash.

Seat belts are the most important part of your occupant protection system. When worn properly, seat belts can reduce the chance of serious injury or death in a crash.

For added protection during a severe frontal collision, your Honda has a Supplemental Restraint System (SRS) with airbags for the driver and a front seat passenger.

Two indicator lights are also part of your safety system. One reminds you to make sure you and your passengers wear seat belts. The other alerts you to a possible problem with your supplemental restraint system (see page 16).

The seats, head restraints and door locks also play a role in occupant safety. For example, reclining the seat-back can decrease the effectiveness of your seat belt. Head restraints can help protect your neck and head, especially during rear-end impacts. Door locks help keep your doors from being accidentally opened during a crash.

To get the maximum protection from your occupant protection system, check the following before you drive away:

- Everyone in the car is wearing a seat belt properly (see page 7).
- Infants and small children are properly secured in child safety seats (see page 20).
- Both doors are closed and locked (see page 19).
- Seat-backs are upright and head restraints are properly adjusted (see pages 18 and 57).
- There are no loose items that could be thrown around and hurt someone during a crash or sudden stop (see page 19).

By following these guidelines, you can reduce injuries to yourself and your passengers in many crash situations. Remember, however, that no safety system can prevent all injuries or deaths that can occur in severe crashes.

## Why Wear Seat Belts

Wearing seat belts, and wearing them properly, is fundamental to your safety and the safety of your passengers.

During a crash or emergency stop, seat belts can help keep you from being thrown against the inside of the car, against other occupants, or out of the car.

Of course, seat belts cannot completely protect you in every crash. But, in most cases, seat belts reduce your chance of serious injury. They can even save your life. That is why many states and all Canadian provinces require you to wear seat belts.

Not wearing a seat belt increases the chance of serious injury or death in a crash.

Be sure you and your passengers always wear seat belts and wear them properly.

## Important Safety Reminders

Seat belts are designed for adults and larger children. All infants and small children must be properly restrained in child safety seats (see page 20).

A pregnant woman needs to wear a seat belt to protect herself and her unborn child (see page 10).

Two people should never use the same seat belt. If they do, they could be very seriously injured in a crash.

Do not place the shoulder portion of a lap/shoulder belt under your arm or behind your back. This could increase the chance of serious injuries in a crash.

Do not put shoulder belt pads or other accessories on seat belts. They can reduce the effectiveness of the belts and increase the chance of injury.

# The Seat Belt System and How It Works

## Seat Belt System Components

Your Honda has seat belts in all five seating positions. The front seats and the outside positions of the rear seat have lap/shoulder belts. The center position of the rear seat has a lap belt.

Your seat belt system also includes a light on the instrument panel to remind you to fasten your seat belt, and to make sure your passengers fasten theirs. This light comes on when you turn on the ignition if you have not fastened your seat belt. A beeper also sounds for several seconds (see page 34).

The following pages cover more about the seat belt components and how they work.

## Lap/Shoulder Belt

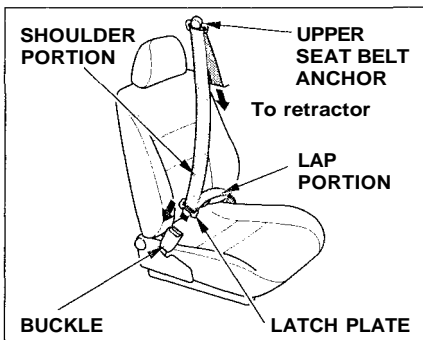

This style of seat belt has a single belt that goes over your shoulder, across your chest, and across your hips.

Each lap/shoulder belt has an emergency locking retractor. In normal driving, the retractor lets you move freely in your seat while it keeps some tension on the belt. During a collision or sudden stop, the retractor automatically locks the belt to help restrain your body.

The lap/shoulder belt retractor in each passenger seating position has an additional locking mechanism intended to secure a child seat (see page 24). If the shoulder part of the belt is pulled all the way out, this mechanism will engage. The belt will retract, but it will not allow the passenger to move freely. If the belt feels too tight, unlatch it, let it retract fully, then pull it out as far as needed.

## Lap Belt

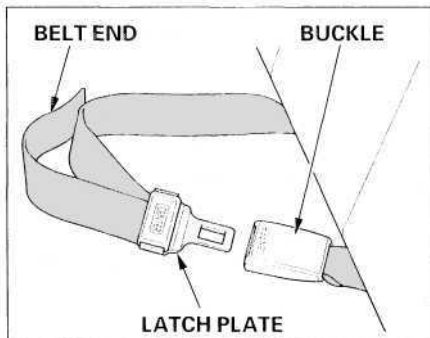

The lap belt has one manually-adjusted belt that fits across the hips. It is similar to safety belts used in airplanes.

## Wearing Seat Belts Properly

You can increase the effectiveness of your seat belts if you take a little time to read the following pages and make sure you know how to wear seat belts properly.

Not wearing a seat belt properly increases the chance of serious injury or death in a crash.

Be sure you and your passengers always wear seat belts and wear them properly.

## Wearing a Lap/Shoulder Belt

Before putting on the seat belt, move the driver's seat as far back as is practical while still allowing you to maintain full control of the vehicle. Make sure the seat-back is upright (see page 18). The front seat passenger should move the seat as far back as possible.

CONTINUED



## The Seat Belt System and How It Works

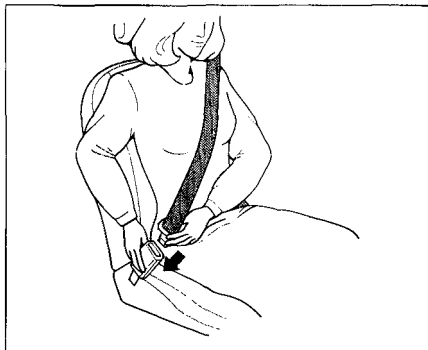

1. Pull the latch plate across your body and insert it into the buckle. Tug on the belt to make sure the latch is securely locked.

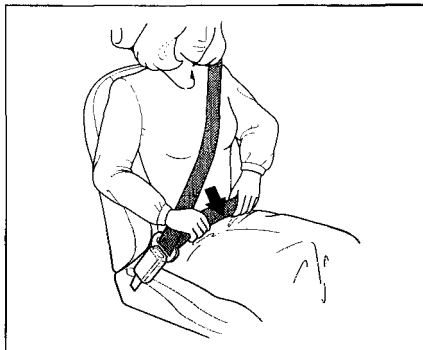

2. Check that the belt is not twisted.
3. Position the lap portion of the belt as low as possible across your hips, not across your stomach. This lets your strong pelvic bones take the force of a crash.

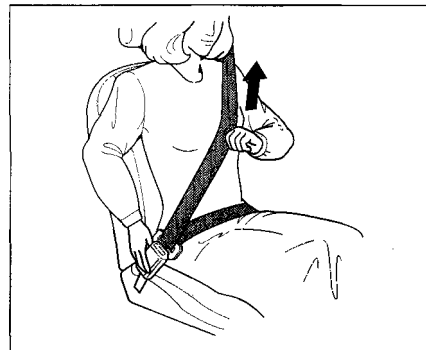

4. Pull up on the shoulder part of the belt to remove any slack. Make sure the belt goes over your collarbone and across your chest.

5. If the shoulder belt crosses your neck while you are sitting in one of the outside positions of the rear seat, you need to adjust your seating position. Move toward the center of the seat until the belt fits over your collarbone.

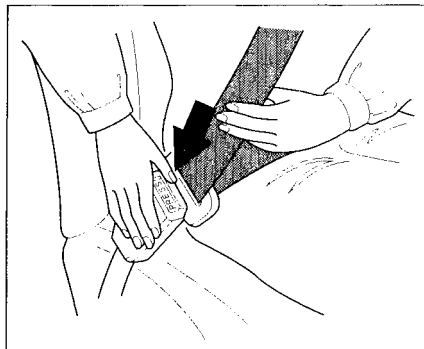

To unlatch the seat belt, push the red PRESS button on the buckle. Guide the belt across your body to the door pillar.

After you exit the vehicle, make sure the seat belt is out of the way and will not get closed in the door.

## Wearing the Lap Belt

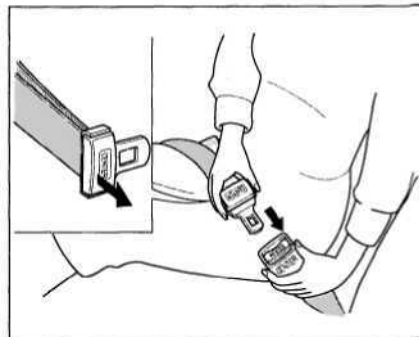

1. Pull the latch plate across your hips and insert it into the buckle marked CENTER.

If the belt is too short, hold the latch plate at a right angle, and pull it to extend the belt. Insert the latch plate into the buckle.

*CONTINUED*

# The Seat Belt System and How It Works

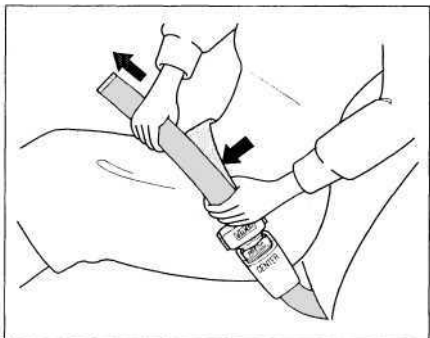

2. Position the belt as low as possible across your hips and pelvic bones, not across your stomach. Pull the loose end of the belt to adjust for a snug but comfortable fit.

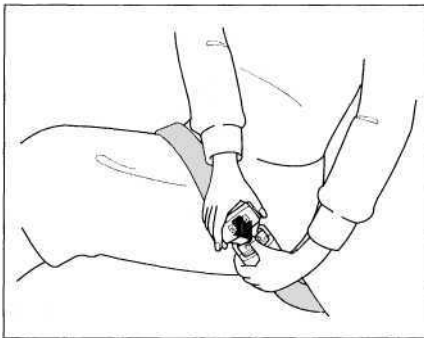

To unlatch the belt, push the red PRESS button on the buckle.

## Advice for Pregnant Women

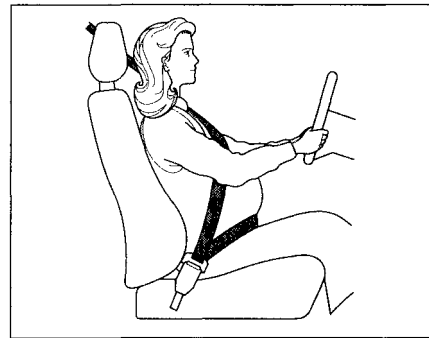

Protecting the mother is the best way to protect her unborn child. Therefore, a pregnant woman should wear a properly-positioned seat belt whenever she drives or rides in a car.

If possible, use a lap/shoulder seat belt, remembering to keep the lap portion as low as possible (see page [7](#)).

Each time you have a check-up, ask your doctor if it's okay for you to drive and how you should position a lap/shoulder seat belt.

### **Seat Belt Maintenance**

For safety, you should check the condition of your seat belts regularly.

Pull out each belt fully and look for frays, cuts, burns, and wear. Check that the latches work smoothly and the lap/shoulder belts retract easily. Any belt not in good condition or not working properly should be replaced.

If a seat belt is worn during a crash, have your dealer replace the belt and inspect the anchors for damage.

For information on how to clean your seat belts, see page [176](#).

Your car is equipped with a Supplemental Restraint System (SRS) to help protect the head and chest of the driver and front seat passenger during a severe frontal collision.

*This system does not replace your seat belts.* It supplements, or adds to, the protection offered by seat belts and other occupant protection features.

Not wearing a seat belt increases the chance of serious injury or death in a crash, even if you have airbags.

Be sure you and your passengers always wear seat belts and wear them properly.

### SRS Components

Your supplemental restraint system includes:

- One airbag in the steering wheel for the driver and another in the dashboard for the passenger.
- Sensors that can detect a severe frontal collision.
- A sophisticated electronic system that continually monitors the sensors, control unit, airbag activators, and all related wiring when the ignition is ON (II).
- An indicator light on the instrument panel to alert you to a possible problem with the system.
- Emergency backup power in case your car's electrical system is disconnected in a crash.

### What Happens In a Crash

If you ever have a severe frontal collision, the sensors will detect rapid deceleration and signal the control unit to instantly inflate the airbags.

During a crash, your seat belts will help to restrain your lower body and torso. The airbags will provide a cushion to absorb crash energy and help keep the head and chest of the driver and front passenger from striking the interior of the car.

After inflating, the airbags will immediately deflate. The entire process, from detection to deflation, takes a fraction of a second. This process occurs so quickly that you may not hear the loud noise created by the airbag inflators, or realize what has happened.

After the crash, you may see what looks like smoke. This is actually powder from the airbag's surface. People with respiratory problems may experience some temporary discomfort from the chemicals used by the airbag's activators.

### Important Facts About Airbags

Airbags inflate only when needed; **in a severe frontal collision**. A severe collision would be similar to a crash into a parked vehicle of similar size and weight at 25 mph (40 km/h). Airbags will not inflate in a moderate frontal collision, or during a rear impact, side impact, or rollover — even if the impact is severe.

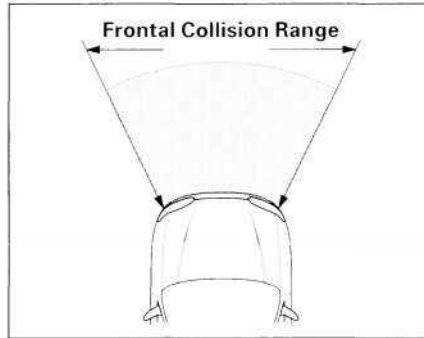

Airbags inflate and deflate only once. They cannot protect you during any additional impacts that can occur

during a crash sequence.

Injuries, including fatal injuries, can occur in a severe collision, even if seat belts are worn properly and the airbags inflate. No safety system can provide complete protection in a severe crash.

Just from viewing the vehicle damage after a crash, it is very difficult to accurately determine if the airbags should or should not have inflated. In some cases where the airbag did not inflate, extensive visible damage indicated that the car absorbed much of the crash energy, and the airbags were not needed. In other cases, a severe jolt, such as an impact to the undercarriage, may not cause extensive body damage but may still cause the airbags to inflate.

## How the Driver's Airbag Works

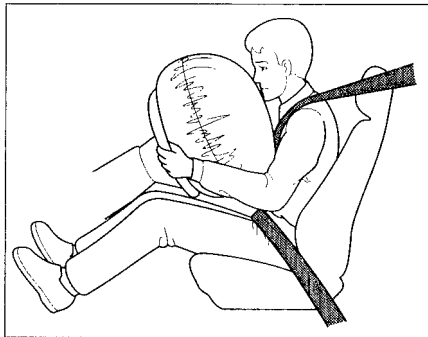

If you ever have a severe frontal collision, your airbag will instantly inflate to help protect your head and chest.

To do its job, the airbag inflates with considerable force. So, while it can reduce serious injuries and even save your life, the airbag might cause some facial abrasions or other injuries. To reduce the possibility of injury, you should always sit back as far from the steering wheel as practical while still maintaining full vehicle control.

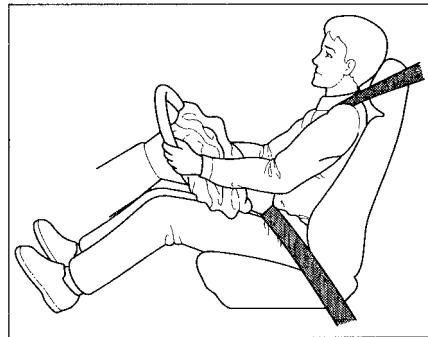

After the bag completely inflates, it immediately starts deflating so it won't interfere with your visibility, ability to steer, or ability to operate other controls. The total time for inflation and deflation is a fraction of a second. You may not even be aware that the airbag has been fully inflated.

The driver's airbag is stored in the center of the steering wheel. For your safety, do not attach any items to the steering wheel. They could interfere with the proper operation of the airbag. Or, if the airbag inflates, they could be propelled inside the car and hurt someone.

### How the Passenger's Airbag Works

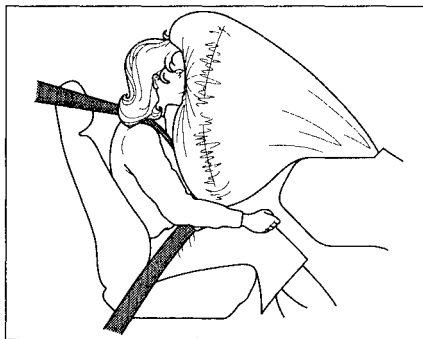

If you ever have a severe frontal collision, the passenger's airbag will inflate at the same time as the driver's airbag.

This airbag is quite large and inflates with considerable force. It can seriously hurt a front seat passenger who is not in the proper position and wearing the seat belt properly.

Front seat passengers should move the seat as far back as practical and sit well back in the seat.

We strongly recommend that you do not put an infant seat in the front passenger's seat. If the airbag inflates, it can hit the infant seat with great force. The infant seat can be dislodged or struck with enough force to cause very serious injury to the infant.

If a toddler seat is used in the front passenger's seat, the vehicle seat should be moved as far back as possible. If the passenger's bag inflates, it could seriously hurt a toddler who is not in the proper position or properly restrained.

*CONTINUED*



The passenger's airbag is stored near the top of the dashboard, under a lid marked SRS. Do not place any objects on top of this lid. If the airbag inflates, those objects can be propelled inside the car and possibly hurt someone.

### **SRS**

#### **How the SRS Indicator Light Works**

The purpose of the SRS light on your instrument panel is to alert you to a potential problem with your supplemental restraint system.

Have the system checked if:

- The light does not come on when you turn the ignition ON (II).
- The light stays on after the engine starts.
- The light comes on or flashes while you are driving.

If you see any of these indications, the airbag may not work when needed in an accident. Take the car to your dealer promptly for diagnosis and service.

#### **System Service**

Your supplemental restraint system is virtually maintenance-free. The only scheduled maintenance is an inspection of the system by the dealer when the car is ten years old. For your convenience, the car's production date is on a label on the driver's doorjamb.

If either of the following happens, you must have an authorized Honda dealer service the system. There are no parts you can safely service.

- If your airbags ever inflate, the airbags and control unit must be replaced. Do not try to remove or discard the airbags yourself. This must be done by a Honda dealer.

- If the SRS indicator light alerts you to a problem, have the supplemental restraint system inspected as soon as possible. If you ignore this indication, the airbags might not inflate when you need them.

### **System Service Precautions**

Do not modify your steering wheel or any other part of the supplemental restraint system. Modifications could make the system ineffective.

Do not tamper with the system's components or wiring. This could cause the airbags to inflate inadvertently, possibly injuring someone very seriously.

Tell anyone who works on your car that you have a supplemental restraint system. Failure to follow the procedures and precautions in the official Honda service manual could result in personal injury or damage to the system.

Scrapping an entire car that has uninflated airbags can be dangerous. Get assistance from a Honda dealer if your car must be scrapped.

If you sell your car, please be sure to tell the new owner that the car has a supplemental restraint system. Alert them to the information and precautions in this part of the owner's manual.

## Additional Safety Information

---

The seat belts and airbags are obviously important parts of your occupant protection system.

In addition, you should know that sitting upright, adjusting the head restraints properly, locking the doors, and stowing things properly can also increase your safety and possibly even save your life.

### Seat-back Position

The seat-backs should be in an upright position for you and your passengers to get the most protection from the seat belts.

If you recline a seat-back, you reduce the protective capability of your seat belt. The farther a seat-back is reclined, the greater the risk that you will slide under the belt in a severe crash and be very seriously injured.

For information on how to adjust the seat-back, see page [56](#).

### Head Restraint Position

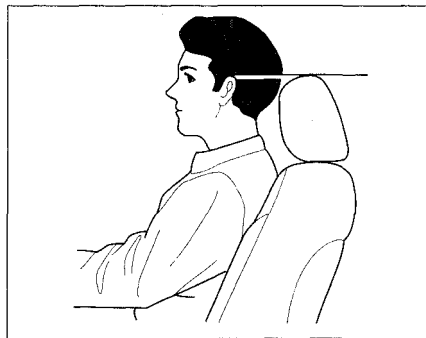

Head restraints can help protect you from whiplash and other injuries. For the best protection, adjust the top of the restraint so it is even with the tops of your ears, or as high as possible. For instructions on adjusting the head restraints, see page [57](#).

### Door Locks

It is not safe to leave your car doors unlocked. A passenger, especially a child, could open a door and accidentally fall out. Also, there is a greater chance of being thrown out of the car during a crash when the doors are not locked.

### Storing Cargo Safely

Before you drive, make sure you first securely store or tie down any items that could be thrown around the car and hurt someone, or interfere with your ability to operate the controls.

Do not put any items on top of the rear shelf. They can block your view and they could be thrown about the car in a crash.

Be sure to keep compartment doors closed when the car is moving. If a front passenger hits the door of an open glove box, for example, he could injure his knees.

For information on loading cargo, see page [98](#).

### Driving with Pets

Loose pets can be a *hazard* while you are driving. An unrestrained pet can interfere with your ability to drive the car. In a crash or sudden stop, loose pets or cages can be thrown around inside the car and hurt you or your passengers. It is also for their safety that pets should be properly restrained in your car.

The recommended way to restrain a medium-sized or larger dog is with a special traveling harness. This harness can be secured to the rear seat with a seat belt. Travel harnesses are available at pet stores.

A small dog, cat, or other small animal will be safest in a pet carrier with rigid sides. Choose a style that allows you to secure it to the car's seat by routing a seat belt through the carrier's handle.

For further information, contact your veterinarian or local animal protection society.



Children depend on adults to protect them. To help make sure we do, every state and Canadian province has laws requiring infants and young children to be properly restrained whenever they ride in a car.

An infant or child who is not properly restrained can be killed or seriously injured in a crash.

Be sure any child too small for seat belts is properly secured in a child restraint.

### **Where Should Children Sit?**

According to accident statistics, children of all sizes and ages are safer when they are properly restrained in the rear seat rather than the front seat.

We recommend that, whenever possible, you secure your child's infant or toddler seat in the center position of the rear seat with the lap belt.

We strongly recommend that you do not put an infant seat in the front passenger's seat. If the airbag inflates, it can hit the infant seat with great force. The infant seat can be dislodged or struck with enough force to cause very serious injury to the infant.

If a toddler seat is used in the front passenger's seat, the vehicle seat should be moved as far back as possible. If the passenger's bag inflates, it could seriously hurt a toddler who is not in the proper position or properly restrained.

We also recommend that any child who is too large to use an infant or toddler seat ride in one of the outside positions of the rear seat. The child should then wear the lap/shoulder belt properly for protection. If the child is not large enough to wear the lap/shoulder belt properly, you should use a booster seat.

### **Important Safety Reminders**

Never hold a baby or child on your lap when riding in a car. If you are wearing your seat belt, the violent forces created during a crash will tear the child from your arms. The child could be seriously hurt or killed.

If you are holding a child and not wearing a seat belt in a crash, you could crush the child against the car's interior.

Never put your seat belt over yourself and a child. During a crash, the belt could press deep into the child, causing serious internal injuries.

Two children should never use the same seat belt. If they do, they could be very seriously injured in a crash.

For their safety, do not leave children alone in your car without adult supervision.

### General Guidelines for Restraining Children Under 40 lbs (18 kg)

*Use an approved child seat.* The seat must meet Federal Motor Vehicle Safety Standard 213 (FMVSS-213) or Canadian Motor Vehicle Safety Standards. Look for the manufacturer's statement of compliance on the box and seat.

*Use a seat of the right size.* Make sure the seat fits your child. Check the seat manufacturer's instructions and labels for height and weight limits.

*Secure the child seat to the car.* All approved child seats are designed to be secured to the car seat by the lap belt or the lap belt portion of a lap/shoulder belt. A child whose seat is not properly secured to the car can be endangered in a crash.

To properly route a seat belt through a child seat, follow the seat maker's instructions. If you use a lap/shoulder belt, be sure to follow the instructions for securing a child seat with a lap/shoulder belt on page 24.

*Secure the child in the child seat.* Make sure the infant or child is firmly secured to the child seat. Use the straps provided, and carefully follow the manufacturer's instructions.

### Restraining an Infant Who Weighs Less Than 20 lbs (9 kg)

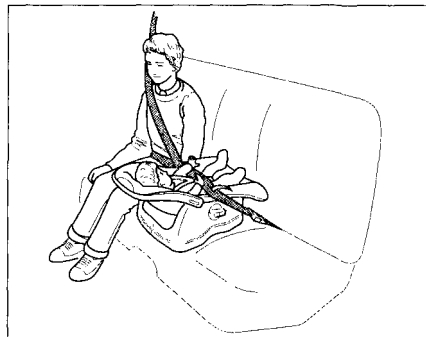

An infant up to about 20 lbs (9 kg) must be restrained in an infant seat or a convertible seat designed for a baby. Because infants must ride in a reclining position, be sure the infant seat always faces the REAR of the car as shown.

We recommend that, whenever possible, you put the infant seat in the center position of the rear seat and secure it to the car with the lap belt.

If you decide to put an infant seat in any other seating position, be sure to follow the instructions for securing a child seat with a lap/shoulder belt on page [24](#).

We strongly recommend that you do not put an infant seat in the front passenger's seat. If the airbag inflates, it can hit the infant seat with great force. The infant seat can be dislodged or struck with enough force to cause very serious injury to the infant.

## Restraining a Child Who Weighs Between 20 and 40 lbs (9 and 18 kg)



Toddler seats are designed for children who weigh between 20 and 40 lbs (9 and 18 kg).

The preferred place to put a toddler seat is in the center position of the rear seat. Use the car's lap belt to secure the seat to the car.

If you decide to put a toddler seat in any other seating position, be sure to follow the instructions for securing a child seat with a lap/shoulder belt on page [24](#).

If you are using a toddler seat in the front passenger's seat, move the passenger's seat as far back as possible before installing the child seat. If the passenger's bag inflates, it could seriously hurt a toddler who is not in the proper position or properly restrained.



### Restraining a Child Who Weighs Over 40 lbs (18 kg)

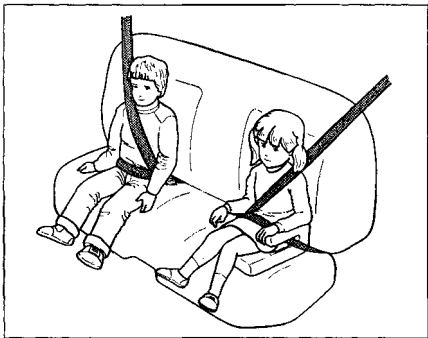

We recommend that, whenever possible, a child who has outgrown a toddler seat ride in one of the outside positions of the rear seat and use a lap/shoulder belt.

Put the lap/shoulder belt on your child and check its fit. The shoulder belt should fit over the collarbone and across the chest. The lap belt should sit low on your child's hips, not across the stomach.

If the shoulder belt crosses the neck, have your child move toward the center of the rear seat until the belt fits properly. If the belt still crosses the child's neck, you should use a booster seat.

Several styles of booster seats are available. We recommend a design that allows the child to use the car's lap/shoulder belt.

Whichever style you select, follow the booster seat manufacturer's instructions.

### Securing a Child Seat with a Lap/Shoulder Belt

The lap/shoulder belt retractors in the passenger seating positions have a built-in locking mechanism intended to secure a child seat. When you are placing a child seat in one of these outside seating positions, do the following:

1. Place the child seat in the desired seating position. Route the lap/shoulder belt through the seat according to the seat manufacturer's instructions.
2. Insert the latch plate into the buckle. Make sure it is fully latched.
3. Slowly pull the shoulder portion of the belt out of the retractor until it stops.

4. Allow the belt to slowly feed back into the retractor. You should hear a clicking noise that indicates the locking mechanism has engaged.
5. After the belt has retracted fully, pull up on the shoulder portion to remove any slack.
6. Push and pull on the child seat to verify that it is held firmly in place. If not, unlatch the seat belt, allow it to retract fully, and repeat these steps.

To unlatch the seat belt, push the red **PRESS** button on the buckle. Guide the belt across to the door pillar. If the belt doesn't retract easily, pull it out and check for twists or kinks.

### Using Child Restraints with Tethers

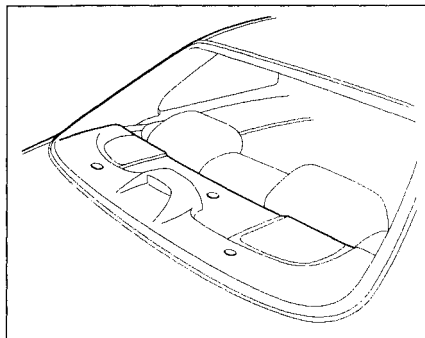

Your Honda has three attachment points for tether-style child seats.

Select the attachment point you want to use and remove the plug with a small flat-tipped screwdriver or fingernail file.

Then install the tether hardware that came with the child seat.

Tighten the bolt to:

22 N.m (2.2 kgf.m, 16 lbf.ft)

If you are not sure how to install the hardware, have it installed by your authorized Honda dealer.

If you need an anchor plate and mounting hardware, contact your Honda dealer.

*CONTINUED*

## Canadian Models

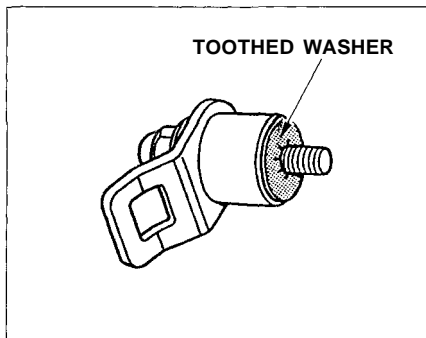

The anchor plate and mounting hardware for a top tether are supplied with the car. When installing, make sure the toothed washer is on the bottom of the bolt.

The supplied anchor plate is designed only for mounting a child restraint. Do not use it for any other purpose.

## Storing a Child Seat

When you are not using an infant seat or other child restraint, either remove it or make sure it is properly secured so it cannot be thrown around the car during a crash.

Driving a car requires your full attention and alertness. Traffic conditions change rapidly. You must be able to react just as rapidly. Alcohol or drugs directly affect your alertness and ability to react. Even prescription and non-prescription medicines can have this effect.

There are laws that deal with drunken driving. These laws define how much alcohol it takes in your system to be legally "drunk." However, your judgment and reaction time get worse with every drink—even the first one.

The safest thing you can do is never drink and drive. This can be done if you plan ahead. If you know you are going to be drinking, make plans to ride with a friend who will not be drinking.

What if you find that you've been drinking and cannot get a ride from a friend? Find alternative transportation. Call a taxi. Take a bus. Many communities have transportation services devoted to shuttling people who have been drinking.

If you have no choice but to drive, stop drinking and give yourself lots of time to sober up. Time is the only thing that can make you sober. Things like coffee or a cold shower don't speed up the process.

If you see friends trying to get behind the wheel after drinking, stop them. Drive them yourself or arrange other transportation. If you think you are interfering, remember that your interference will keep them from sharing the road with you.

## Carbon Monoxide Hazard

---

Your car's exhaust contains carbon monoxide gas. You should have no problem with carbon monoxide entering the car in normal driving if you maintain your car properly. Have the exhaust system inspected for leaks whenever:

- The car is raised for an oil change.
- You notice a change in the sound of the exhaust.
- The car was in an accident that may have damaged the underside.

Carbon monoxide gas is toxic. Breathing it can cause unconsciousness and even kill you.

Avoid any enclosed areas or activities that expose you to carbon monoxide.

High levels of carbon monoxide can collect rapidly in enclosed areas, such as a garage. Do not run the engine with the garage door closed. Even with the door open, run the engine only long enough to move the car out of the garage.

With the trunk lid open, air flow can pull exhaust gas into your car's interior and create a hazardous condition. If you must drive with the trunk lid open, open all the windows and set the heating and cooling system as shown below.

If you must sit in your parked car, even in an unconfined area, with the engine running, adjust the heating and cooling system as follows:

1. Select the Fresh Air mode.
2. Select the  mode.
3. Turn the fan on high speed,
4. Set the temperature control to a comfortable setting.

These labels are in the locations shown. They warn you of potential hazards that could cause serious injury. Read these labels carefully and don't remove them.

If a label comes off or becomes hard to read, contact your Honda dealer for a replacement.

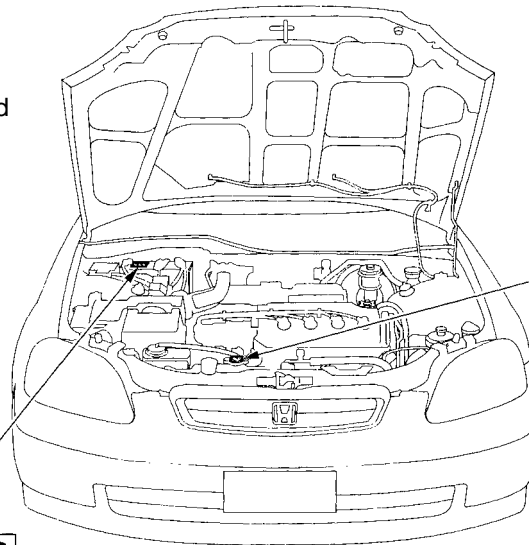

## BATTERY

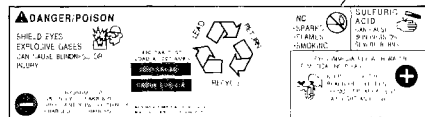

## RADIATOR CAP



This section gives information about the controls and displays that contribute to the daily operation of your Honda. All the essential controls are within easy reach.

Control Locations.....	32	Ignition Switch.....	49
Indicator Lights.....	33	Door Locks.....	50
Gauges.....	37	Power Door Locks.....	51
Speedometer.....	37	Remote Transmitter.....	52
Tachometer.....	37	Trunk.....	55
Odometer.....	37	Seat Adjustments.....	56
Trip Meter.....	37	Front Seat Adjustments.....	56
Fuel Gauge.....	38	Rear Seat Access.....	57
Temperature Gauge.....	38	Head Restraints.....	57
Maintenance Required		Folding Rear Seat.....	58
Indicator.....	39	Power Windows.....	59
Controls Near the Steering		Moonroof.....	61
Wheel.....	40	Mirrors.....	61
Headlights.....	41	Adjusting the Power Mirrors.....	62
Daytime Running Lights.....	41	Parking Brake.....	62
Instrument Panel Brightness.....	42	Glove Box.....	63
Turn Signals.....	42	Beverage Holder.....	64
Windshield Wipers.....	43	Accessory Power Socket.....	65
Windshield Washers.....	43	Ashtrays.....	65
Hazard Warning.....	44	Interior Light.....	66
Rear Window Defogger.....	44		
Steering Wheel Adjustment.....	45		
Steering Wheel Controls .....	46		
Cruise Control.....	46		
Keys and Locks.....	49		
Keys.....	49		

# Control Locations

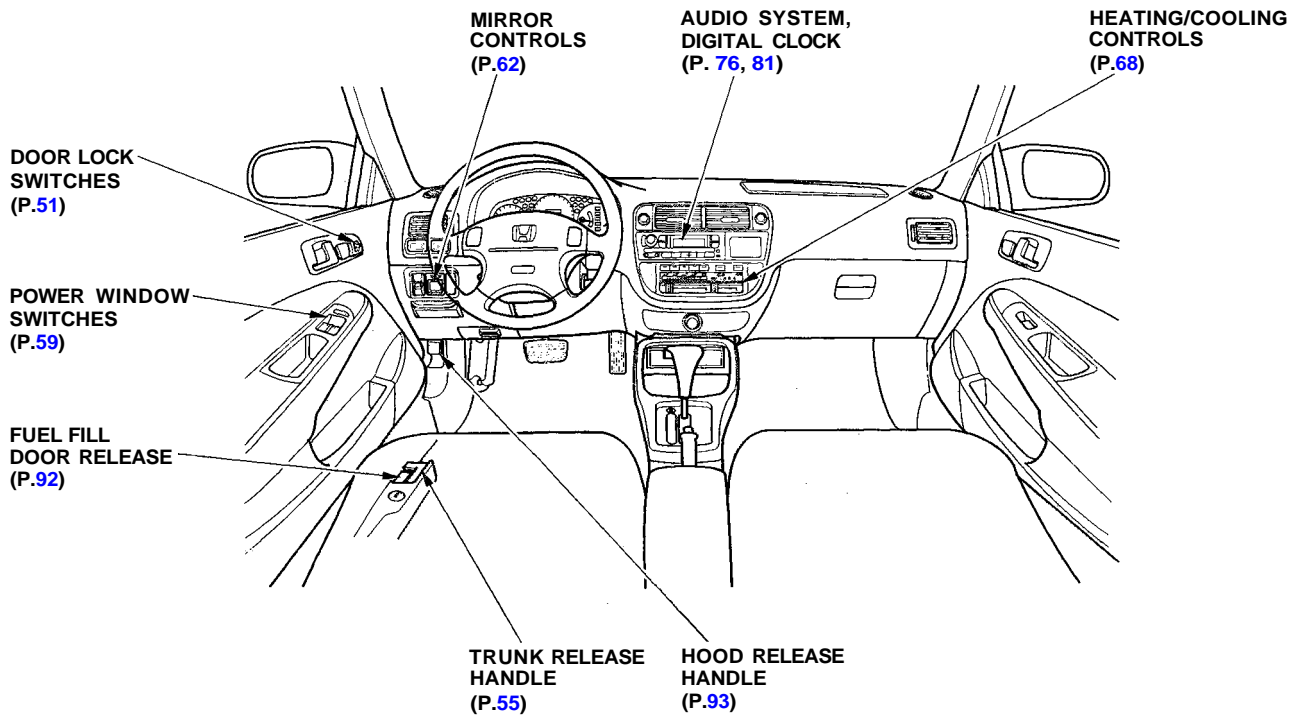



The instrument panel has many indicators to give you important information about your car.

## Lamp Check

These indicator lights come on when you turn the ignition switch ON (II), allowing you to see that they are working:

- SRS Indicator
- Malfunction Indicator Lamp
- Charging System Indicator
- Low Oil Pressure Indicator
- Anti-lock Brake System Indicator
- Seat Belt Reminder Light
- D<sub>4</sub> Lamp

If an indicator does not light during this test, it cannot alert you if that system develops a problem. Have the dealer check your car for burned-out bulbs or other problems.

\* The U.S. instrument panel is shown. Differences for the Canadian model are noted in the text.

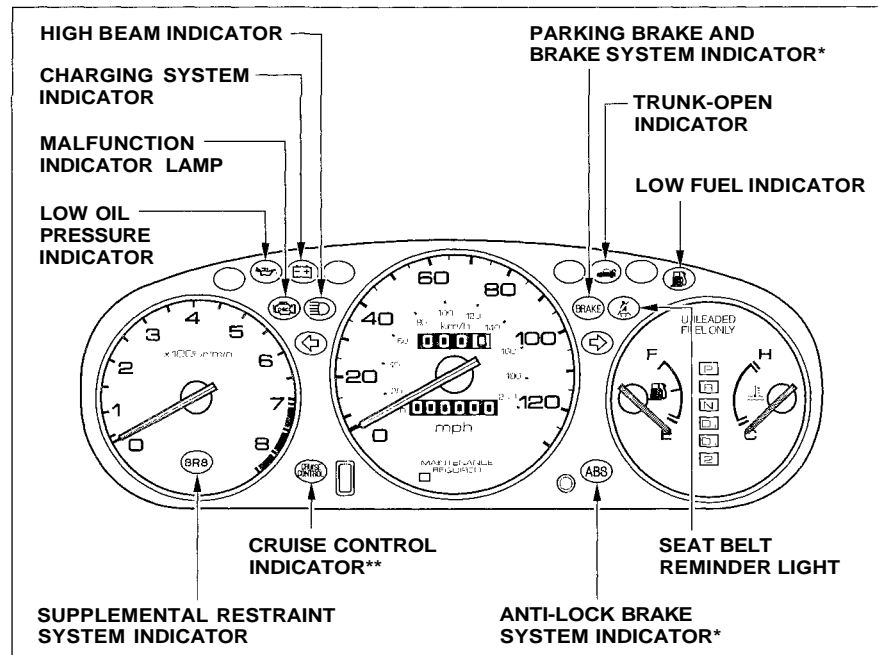

\*\* The HX model with manual transmission has an upshift indicator  in this position.

# Indicator Lights

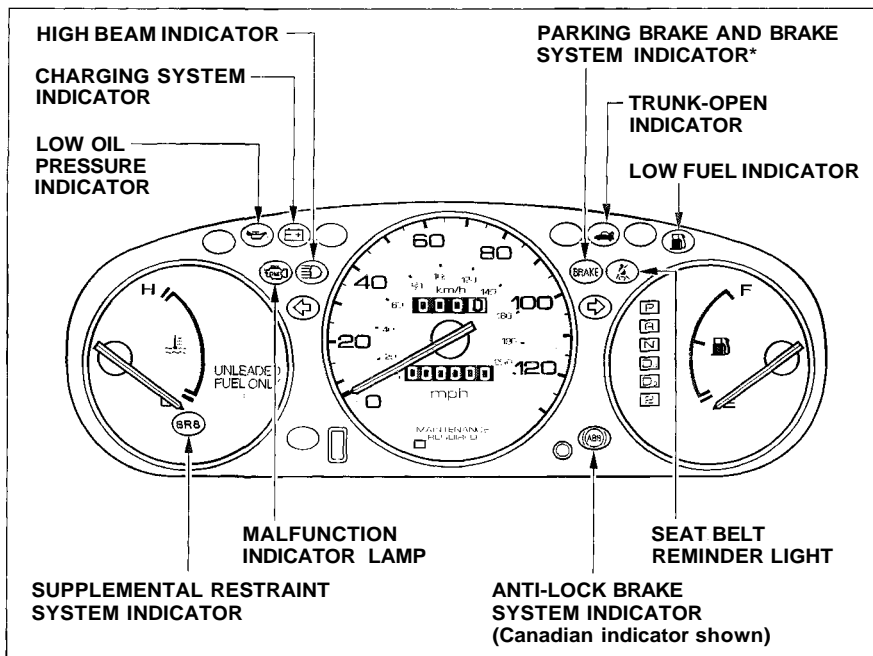

\* Differences in the indicators for Canadian models are noted in the text.



## Seat Belt Reminder Light

This indicator lights when you turn the ignition ON (II). It is a reminder to you and your passengers to protect yourselves by fastening the seat belts. A beeper also sounds if you have not fastened your seat belt.

If you do not fasten your seat belt, the beeper will stop after a few seconds but the light stays on until you do. Both the light and the beeper stay off if you fasten your seat belt before turning on the ignition.



## Supplemental Restraint System Indicator

This indicator lights when you turn the ignition ON (II). If it comes on at any other time, it indicates a problem in the supplemental restraint system. For complete information, see page

16.

**Charging System Indicator**

If this light comes on when the engine is running, the battery is not being charged. For complete information, see page [192](#).

**Low Oil Pressure Indicator**

The engine can be severely damaged if this light flashes or stays on when the engine is running. For complete information, see page [191](#).

**High Beam Indicator**

This light Comes on with the high beam headlights. See page [41](#) for information on the headlight controls.

On Canadian models, this indicator comes on with reduced brightness when the Daytime Running Lights (DRL) are on (see page [41](#)).

**Parking Brake and Brake System Indicator**

This light has two functions:

1. It lights as a reminder that you have not released the parking brake. Driving with the parking brake applied can damage the brakes and tires.
2. If it remains lit after you release the parking brake, or comes on while driving, it can indicate that the brake fluid level is low. This is normally due to worn brake pads. Have your dealer check the braking system for worn pads or fluid leaks.

**Malfunction Indicator Lamp**

See page [193](#).

**Anti-lock Brake System (ABS) Indicator**

*Only on cars equipped with ABS (see page [117](#))*

This light normally comes on for a few seconds when you turn the ignition ON (II), and when the ignition switch is turned to START (III). If this light comes on at any other time, there is a problem in the ABS. If this happens, take the car to your dealer to have it checked. With the light on, your car still has normal braking ability but no anti-lock.



### Turn Signal and Hazard Warning Indicators

The left or right turn signal light blinks when you signal a lane change or turn. If the light does not blink or blinks rapidly, it usually means one of the turn signal bulbs is burned out (see page 166). Replace the bulb as soon as possible, since other drivers cannot see that you are signalling.

When you turn on the Hazard Warning switch, both turn signal lights blink. All turn signals on the outside of the car should flash.



### Trunk-open Indicator

This light comes on if the trunk lid is not closed tightly.



### Low Fuel Indicator

This light comes on as a reminder that you must refuel soon.



### Upshift Indicator

*On HX model with manual transmission*

The upshift indicator's purpose is to help you get better fuel economy. It does this by lighting to inform you of the most economical point to upshift your manual transmission.

You get the best fuel economy by driving in the highest gear practical for your road speed, and by using light to moderate pressure on the accelerator pedal. When you are accelerating moderately, the upshift indicator will light when it is the best time to shift to the next higher gear. By shifting as soon as the light comes on, you will keep the engine operating in its most economical range. The upshift indicator will then go out until it is time to upshift again.

Some road or traffic conditions may require you to accelerate more rapidly or press the accelerator pedal almost to the floor. The light will not come on under those conditions.



### Cruise Control Indicator

*Only on cars equipped with Cruise Control System*

This lights when you set the cruise control. See page 46 for information on operating the cruise control.

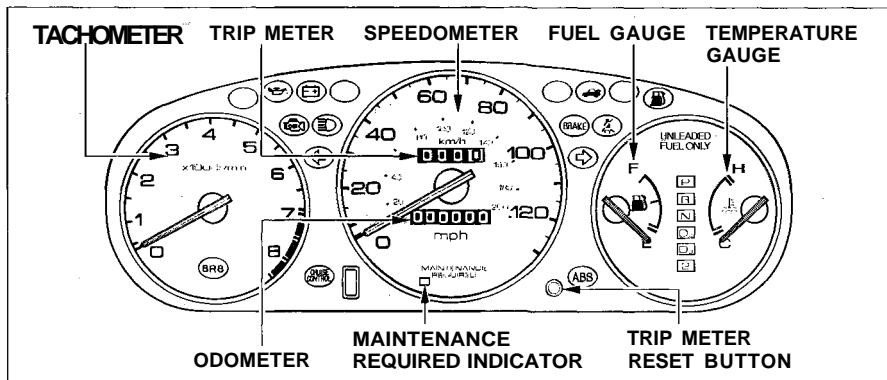

### Speedometer

#### *U.S. Models*

This shows your speed in miles per hour (mph). The smaller inner numbers are the speed in kilometers per hour (km/h).

#### *Canadian Models*

This shows your speed in kilometers per hour (km/h). The smaller inner numbers are the speed in miles per hour (mph).

### Tachometer

*On HX and EX models in the U.S., and Si model in Canada*

The tachometer shows the engine speed in revolutions per minute (rpm). To protect the engine from damage, never drive with the tachometer needle in the red zone.

### Odometer

The odometer shows the total distance your car has been driven. It measures miles in U.S. models and kilometers in Canadian models. It is illegal under federal law (in the U.S.) and provincial regulations (in Canada) to disconnect, reset, or alter the odometer with the intent to change the number of miles or kilometers indicated.

### Trip Meter

This meter shows the number of miles (U.S.) or kilometers (Canada) driven since you last reset it. To reset it, push the trip meter reset button.

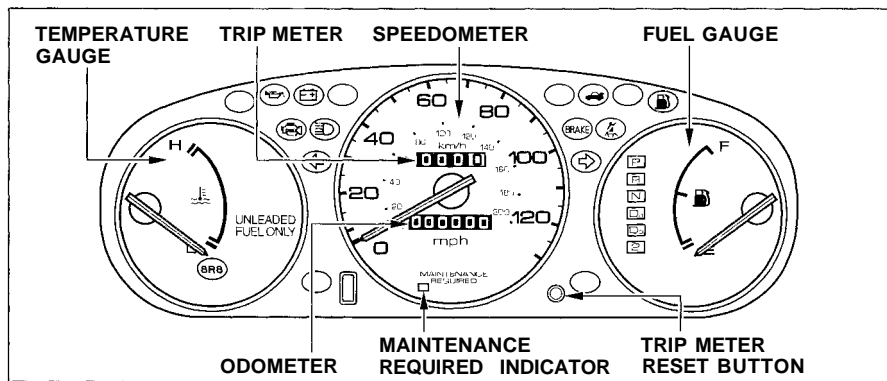

## Fuel Gauge

This shows how much fuel you have. It is most accurate when the car is on level ground. It may show slightly more or less than the actual amount when you are driving on curvy or hilly roads.

The gauge stays at the same fuel level reading after you turn off the ignition. When you add fuel, the gauge slowly changes to the new reading after you turn the ignition back ON (II).

## Temperature Gauge

This shows the temperature of the engine's coolant. During normal operation, the pointer should rise from the bottom white mark to about the middle of the gauge. In severe driving conditions, such as very hot weather or a long period of uphill driving, the pointer may rise to the upper blue zone. If it reaches the red (Hot) mark, pull safely to the side of the road. Turn to page 189 for instructions and precautions on checking the engine's cooling system.

## Maintenance Required Indicator

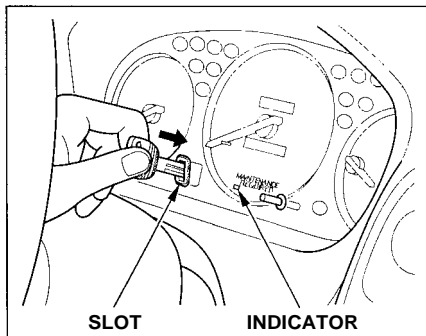

### *U.S. Models*

This indicator reminds you that it is nearing 7,500 miles (12,000 km) since the last scheduled maintenance. Refer to the Maintenance Schedules for Normal and Severe Driving Conditions on pages [126](#) — [127](#).

When the distance driven since the last scheduled maintenance nears 7,500 miles (12,000 km), the indicator will turn yellow. If you exceed 7,500 miles (12,000 km), the indicator will turn red. Your dealer will reset the indicator when he performs the scheduled maintenance. If someone else performs the maintenance, reset the indicator by inserting your key in the slot beside the indicator.

## Controls Near the Steering Wheel

The two levers on the steering column contain controls for driving features you use most often. The left lever controls the turn signals, headlights, and high beams. The right lever controls the windshield washers and wipers.

The rear window defogger switch is on the dashboard to the right of the center air vents.

The controls under the left air vent are for the moonroof, mirrors, cruise control and instrument panel brightness.

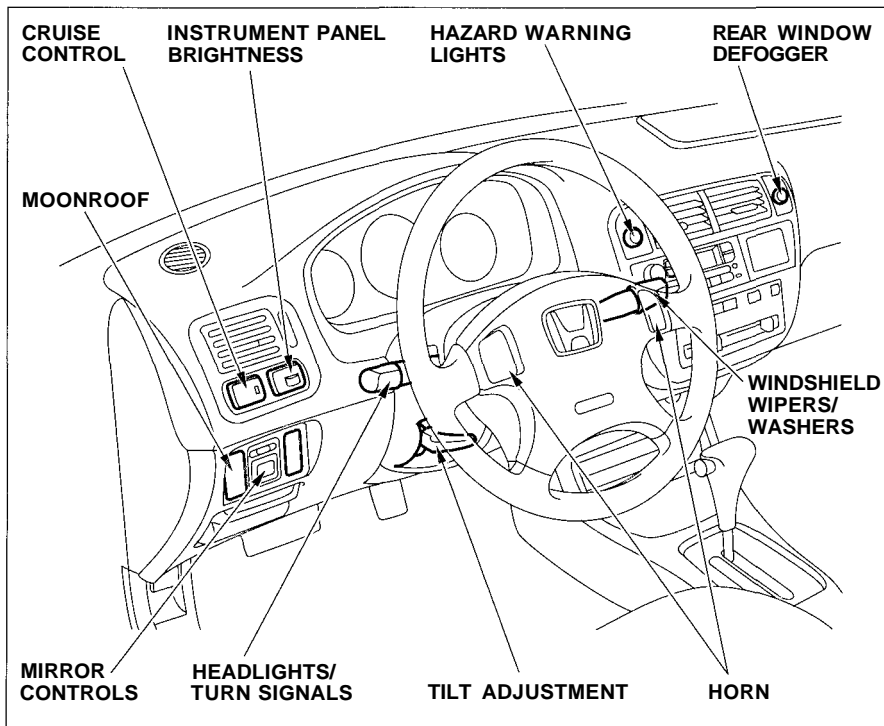

The tilt adjustment lever on the underside of the steering column allows you to tilt the steering wheel.



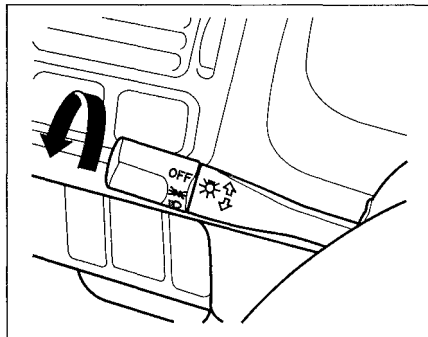

## Headlights



The rotating switch on the left lever controls the lights. Turning this switch to the “” position turns on the parking lights, taillights, instrument panel lights, side-marker lights, and rear license plate lights. Turning the switch to the “” position turns on the headlights.

If you leave the lights on with the ignition switch in ACCESSORY (I) or LOCK (0), you will hear a reminder beeper when you open the driver's door.

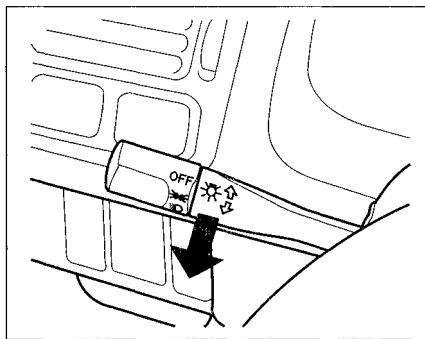

To change between low beams and high beams, pull the turn signal lever until you hear a click, then let go. The blue high beam indicator will light (see page 35).

To flash the high beams, pull the turn signal lever back lightly, then release it. The high beams will come on and go off.

The high beams will stay on for as long as you hold the lever back, no matter what position the headlight switch is in.

## Daytime Running Lights (Canadian Models)

With the headlight switch off, the high beam headlights come on with reduced brightness when you turn the ignition switch to ON (II) and release the parking brake. They remain on until you turn the ignition off, even if you set the parking brake.

The headlights revert to normal operation when you turn them on with the switch.

# Controls Near the Steering Wheel

## Instrument Panel Brightness

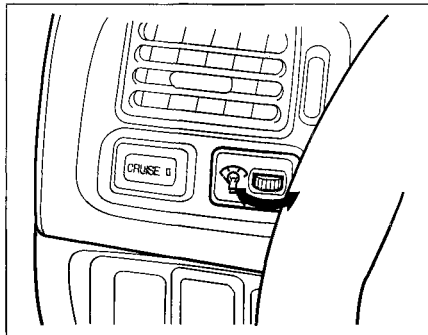

The dial on the dashboard to the left of the instrument panel controls the brightness of the instrument panel lights. Turn the dial to adjust the brightness.

## Turn Signals

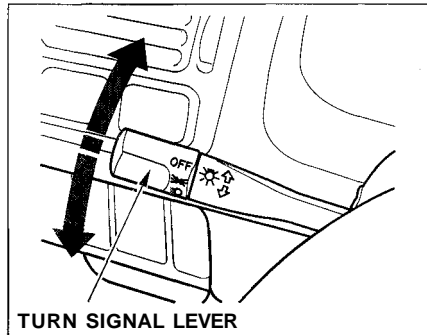

Signal a turn or lane change with this lever. Push down on the lever to signal a left turn, and up to signal a right turn. If you push it up or down all the way, the turn signal continues to blink even when you release the lever. It shuts off automatically as you complete the turn.

To signal a lane change, push lightly on the turn signal lever in the proper direction and hold it. The lever will return to the center position as soon as you release it.

## Windshield Wipers

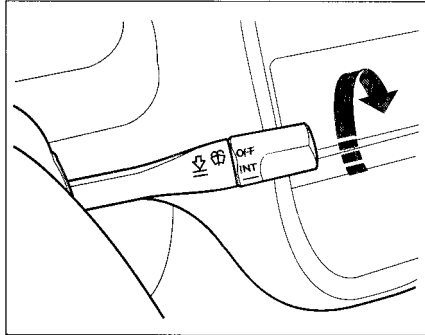

The right lever controls the windshield wipers and washers. The rotary switch at the end of the lever has three positions:

- INT : intermittent
- : low speed
- : high speed

In intermittent, the wipers operate every few seconds. In low speed and high speed, the wipers run continuously.

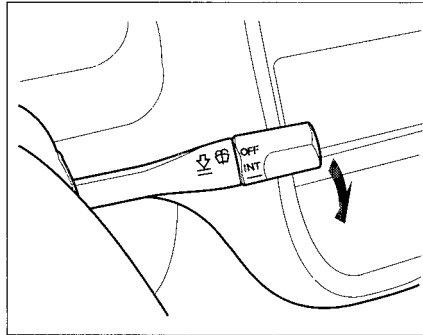

To operate the wipers in mist mode, push the control lever down. The wipers run at high speed until you release the lever. This gives you a quick way to clear the windshield.

## Windshield Washers

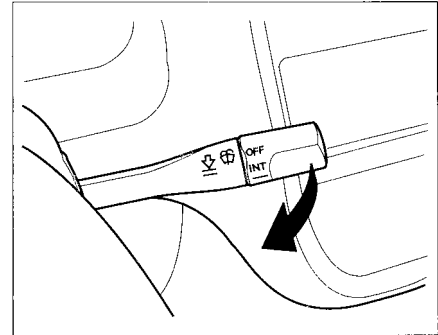

To clean the windshield, pull back on the wiper control lever. The washers spray until you release the lever.

*On Canadian models*

The wipers run at low speed while you're pulling the lever, then complete one more sweep of the windshield after you release it.

### Hazard Warning

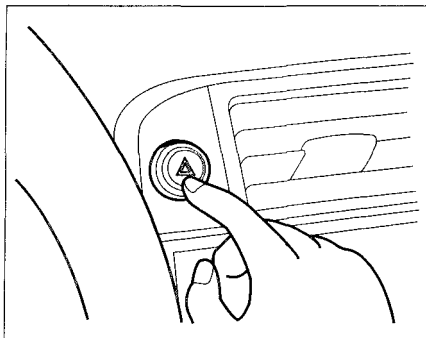

Push the red button to the left of the center vents to turn on the hazard warning lights (four-way flashers). This causes all four outside turn signals and both indicators in the instrument panel to flash. Use the hazard warning lights if you need to park in a dangerous area near heavy traffic, or if your car is disabled.

### Rear Window Defogger

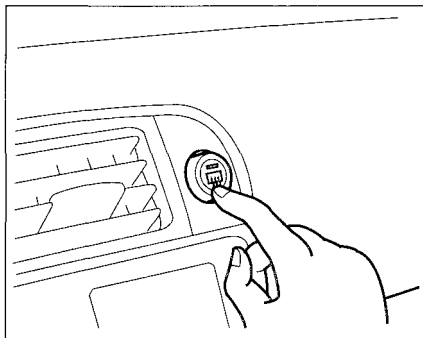

The rear window defogger will clear fog, frost, and thin ice from the window. Push the defogger button to turn it on and off. The light in the button lights to show the defogger is on. If you do not turn it off, the defogger will shut itself off after about 25 minutes. It also shuts off when you turn off the ignition. You have to turn it on again when you restart the car.

Make sure the rear window is clear and you have good visibility before starting to drive.

The defogger wires on the inside of the rear window can be accidentally damaged. When cleaning the glass, always wipe side to side.

### Steering Wheel Adjustment

You can adjust the steering wheel height to suit your preference. Do this before you begin driving.

Adjusting the steering wheel position while driving may cause you to lose control of the car and be seriously injured in a crash.

Adjust the steering wheel only when the car is stopped.

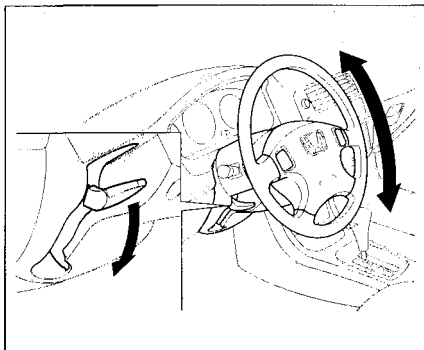

1. Adjust the seat so you are a comfortable distance from the pedals and can operate them safely.
2. The lever to tilt the steering wheel is under the steering column to the left. Push this lever all the way down.

3. Move the steering wheel up or down to the desired position. Position the wheel so you can see all the instrument panel gauges and warning lights. Push the lever up to lock the steering wheel in that position.
4. Make sure you have securely locked the steering wheel in place by trying to move it up and down.

## Cruise Control

On EX model in the U.S.. and Si model in Canada

Cruise control allows you to maintain a set speed above 25 mph (40 km/h) without keeping your foot on the accelerator pedal. It should be used for cruising on straight, open highways. It is not recommended for conditions such as city driving, winding roads, slippery roads, heavy rain, or bad weather. You should have full control of the car under those conditions.

Improper use of the cruise control can lead to a crash.

Use the cruise control only when traveling on open highways in good weather.

### NOTICE

*The cruise control, as it operates, moves the accelerator pedal. You can damage your car's accelerator mechanism by resting your foot under the pedal and blocking the movement.*

## Using the Cruise Control

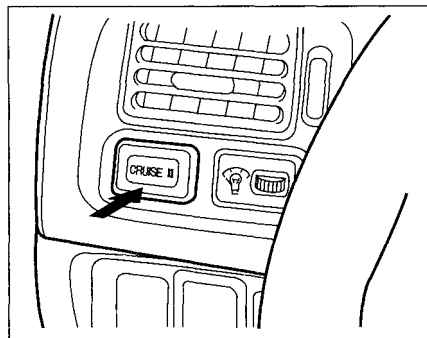

1. Push in the Cruise Control Master Switch to the left of the steering column. The indicator in the switch will light.
2. Accelerate to the desired cruising speed above 25 mph (40 km/h).

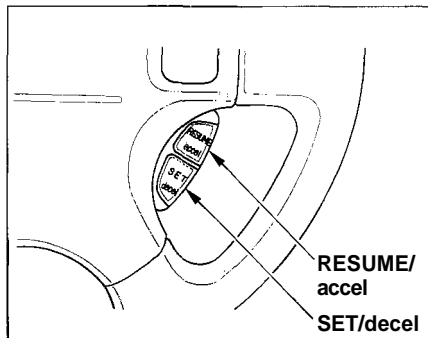

3. Press and hold the SET/decel button on the steering wheel until the CRUISE CONTROL light on the instrument panel comes on. This shows the system is now activated.

The set speed may vary slightly, particularly on hills.

### ***Changing the Set Speed***

You can increase the set cruising speed in either of two ways:

- Press and hold the RESUME/accel button. The car will accelerate slowly. When you reach the desired cruising speed, release the button.
- Push on the accelerator pedal. Accelerate to the desired cruising speed and press the SET/decel button.

You can decrease the set cruising speed in either of two ways:

- Press and hold the SET/decel button. The car will decelerate. Release the button when you reach the desired speed.
- Tap the brake or clutch pedal lightly with your foot. The CRUISE CONTROL light on the instrument panel will go out. When the car slows to the desired speed, press the SET/decel button. The car will then maintain the desired speed.

CONTINUED

Even with the cruise control turned on, you can still use the accelerator pedal to speed up for passing. After completing the pass, take your foot off the accelerator pedal. The car will return to the set cruising speed.

Resting your foot on the brake or clutch pedal will cause the cruise control to cancel.

### ***Cancelling the Cruise Control***

You can cancel the cruise control in any of these ways:

- Tap the brake or clutch pedal.
- Press the SET/decel and RESUME/accel buttons at the same time.
- Press the Cruise Control Master Switch.

When you tap the brake or clutch pedal, or press the SET and RESUME buttons at the same time, the CRUISE CONTROL light on the instrument panel will go out and the car will begin to slow down. You can use the accelerator pedal in the normal way.

If you use the brake or clutch pedal to cancel cruise control, the system remembers the previously-set cruising speed. To return to that

speed, accelerate to above 25 mph (40 km/h) and press the RESUME/accel button until the CRUISE CONTROL light comes on. The car will accelerate to the same cruising speed as before.

If you cancel cruise control by pressing the SET and RESUME buttons at the same time, the previously-set cruising speed is erased. To use the cruise control, accelerate to the desired cruising speed and press the SET/decel button.

Pressing the Cruise Control Master Switch turns the system completely off and erases the previous cruising speed from memory. To use the system again, refer to ***Using the Cruise Control.***



## Keys

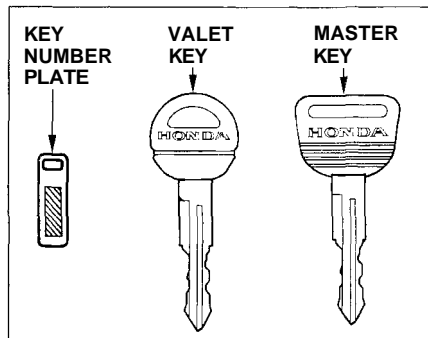

Your vehicle comes with two kinds of keys: a master key and a valet key. The master key fits all the locks on your car:

- Ignition
- Doors
- Trunk
- Trunk release handle
- Rear seat trunk access

The valet key works only in the ignition and the door locks. You can keep the trunk, trunk release handle and rear seat trunk access locked when you leave your car and valet key at a parking facility. (See Trunk, page 55.)

You should have received a key number plate with your set of keys. You will need this key number if you ever have to get a lost key replaced. Keep the plate stored in a safe place. When replacing keys, use only Honda-approved key blanks.

## Remote Transmitter

*On U.S. EX model*

Your car also comes with two remote transmitters; see page 52 for an explanation of the operation.

## Ignition Switch

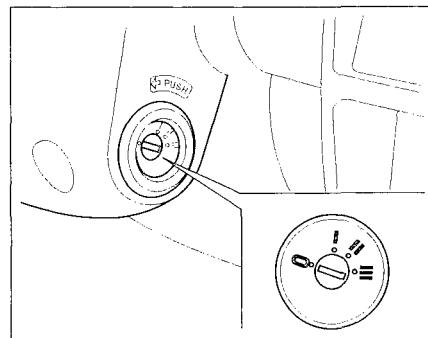

The ignition switch is on the right side of the steering column. It has four positions:

- LOCK (0)
- ACCESSORY (I)
- ON (II)
- START (III)

CONTINUED

**LOCK (0)** — You can insert or remove the key only in this position. When you turn the key from LOCK to ACCESSORY, you may have to turn the steering wheel to release the anti-theft lock. To switch from ACCESSORY to LOCK, you must push the key in slightly as you turn it. If your car has an automatic transmission, it must also be in Park. The anti-theft lock will lock the steering column when you remove the key.

Removing the key from the ignition switch while driving locks the steering. This can cause you to lose control.

Remove the key from the ignition switch only when parked.

**ACCESSORY (I)** — In this position, you can operate the audio system and the accessory power socket.

**ON (II)** — This is the normal key position when driving. All features and accessories on the car are usable. Several of the lights on the instrument panel come on as a test when you turn the ignition switch from ACCESSORY to ON (see page 33).

**START (III)** — Use this position only to start the engine. The switch returns to ON (II) when you let go of the key.

You will hear a reminder beeper if you leave the key in the ignition switch in the LOCK (0) or ACCESSORY (I) position and open the driver's door. Remove the key to turn off the beeper.

### Door Locks

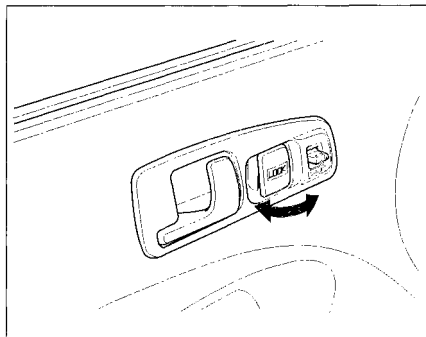

Each door has a lock tab next to the inside door handle. Push the tab in to lock the door and pull it out to unlock.

To lock the passenger's door when getting out of the car, push the lock tab in and close the door. To lock the driver's door, pull the door handle and push the lock tab in. Release the handle, then close the door.

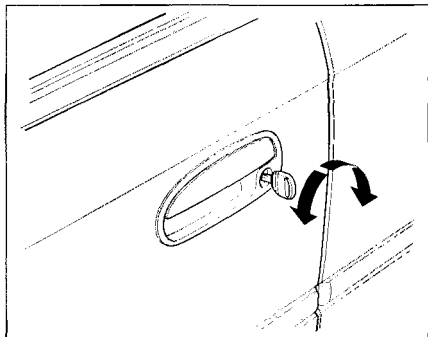

The doors can also be locked and unlocked from the outside with the key.

## Power Door Locks

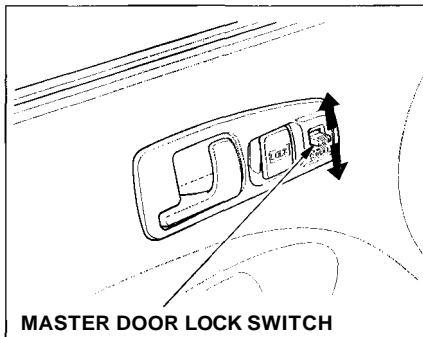

*On HX and EX models in the U.S., and Si model in Canada*

The master door lock switch allows control of both door locks from the driver's door. Push the switch down to lock both doors, and up to unlock them.

Both doors lock when you push the lock tab on the driver's door in, or lock the driver's door from the outside with the key. Only the driver's door unlocks when you use the key or lock tab. To unlock the passenger's door, use the master door lock switch or the lock tab on passenger's door.

## Remote Transmitter

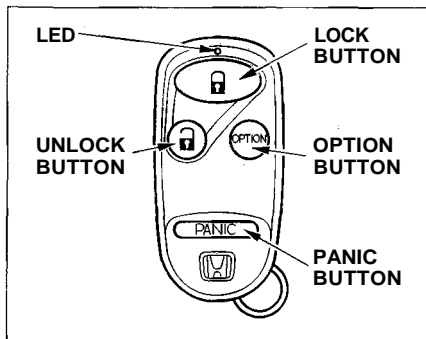

*On EX model in the U.S.* You can lock and unlock your vehicle with the remote transmitter. When you push the LOCK button, both doors lock.

When you push the UNLOCK button once, only the driver's door unlocks. The passenger's door unlocks when you push the button a second time.

The interior light (if the interior light switch is in the center position) will come on when you press the UNLOCK button. If you do not open either door, the light will go out in about 30 seconds and the doors will automatically relock. If you relock the doors with the remote transmitter before 30 seconds have elapsed, the light will go off immediately.

If you installed a non-Honda radio in your car, the keyless entry system and the interior light will no longer work.

You cannot lock or unlock the doors with the remote transmitter if either door is not fully closed or the key is in the ignition switch.

## Horn Operation

You can program the remote transmitter to have the horn beep when you lock and unlock the doors. It will beep once when you lock the doors, and twice when you unlock them.

To turn this feature on and off, press the OPTION and LOCK buttons at the same time for two seconds. If you are turning the horn on, the remote transmitter's LED will come on for one second. If you are turning the horn off, the LED will blink twice. Release the buttons after the LED goes out.

The horn feature will be off after you install a new battery in the remote transmitter. Use the above procedure to turn it on again.

## Panic Mode

Panic mode allows you to remotely sound your car's horn to attract attention. To activate this mode, press and hold the PANIC button for about one second. Your car's horn will beep for about 30 seconds.

To cancel PANIC mode before 30 seconds, press any button on the remote transmitter. You can also turn the ignition switch to ACCESSORY (I) or ON (II).

Panic mode will not activate if the ignition switch is in ACCESSORY (I) or ON (II).

## Replacing the Battery

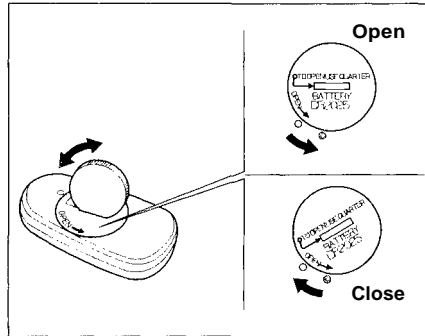

When the remote transmitter's battery begins to get weak, it may take several pushes on the button to lock or unlock the doors, and the LED will get dim. Replace the battery as soon as possible.

Battery type: CR2025

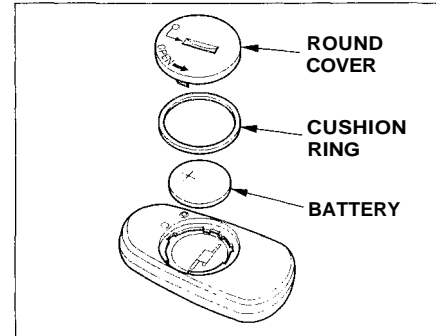

To replace the battery, remove the round cover on the back of the transmitter by turning it counterclockwise with a coin.

Remove the old battery and note the polarity. Make sure the polarity of the new battery is the same (+ side facing up), then insert it in the transmitter.

CONTINUED

Reinstall the cushion ring. Align the → mark on the cover with the © mark on the transmitter, then set the cover in place and turn it clockwise.

After the battery is changed, the transmitter must be synchronized with the main unit. With the doors and trunk lid closed, press either the LOCK or UNLOCK button six times.

Test the transmitter by locking and unlocking the doors several times.

### **Transmitter Care**

Avoid severe shock to the transmitter, such as dropping or throwing it. Also, protect it from extreme hot or cold temperatures.

Clean the transmitter case with a soft cloth. Do not use strong cleaners or solvents that could harm the case. Immersing the transmitter in any liquid will harm the transmitter and cause it to not function properly.

Use the ring on the transmitter to attach it to your main key ring. You could damage the transmitter if you try to use its ring as a key ring.

If you lose a transmitter, you will need to have the replacement programmed to your car's system by your Honda dealer. Any other transmitters you have will also need to be reprogrammed.

*As required by the FCC:*

*This device complies with Part 15 of the FCC rules. Operation is subject to the following two conditions: (1) This device may not cause harmful interference, and (2) this device must accept any interference received, including interference that may cause undesired operation.*

*Changes or modifications not expressly approved by the party responsible for compliance could void the user's authority to operate the equipment.*

## Trunk



You can open the trunk in two ways:

- Pull the trunk release handle to the left of the driver's seat.
- Use the master key to open the trunk lock. The valet key does not work in this lock.

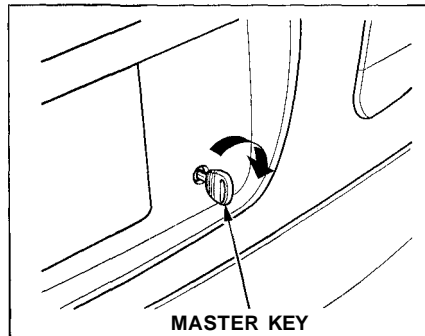

To close the trunk, press down on the trunk lid.

See page [98](#) for cargo loading and weight limit information. Keep the trunk lid closed at all times while driving to avoid damaging the lid, and to prevent exhaust gas from getting into the interior. See **Carbon Monoxide Hazard** on page [28](#).

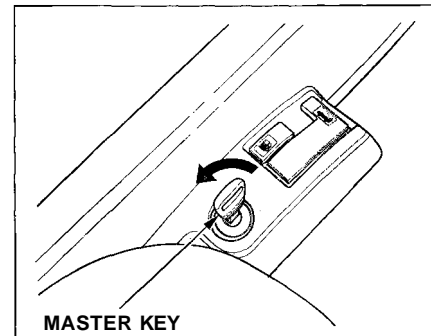

To protect items in the trunk when you need to give the key to someone else, lock the trunk release handle with the master key and give the other person the valet key.

# Seat Adjustments

## Front Seat Adjustments

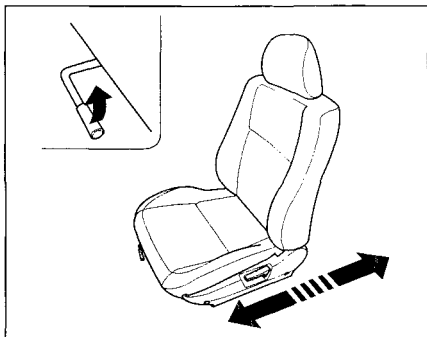

Adjust the seat before you start driving.

To adjust the seat forward and backward, pull up on the lever under the seat cushion's front edge. Move the seat to the desired position and release the lever. Try to move the seat to make sure it is locked in position.

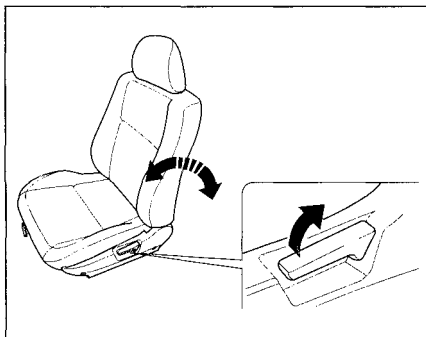

To change the angle of the seat-back, pull up on the lever on the outside of the seat bottom. Move the seat-back to the desired position and release the lever. Let the seat-back latch in the new position.

Reclining the seat-back can decrease the protection you get from your seat belt in a crash.

You can slide under the seat belt and be seriously injured.

Adjust the seat-back to an upright position and sit well back in the seat.



## Rear Seat Access

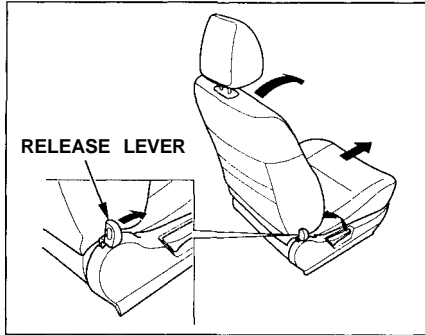

To get into the back seat on the driver's side, pull up on the seat-back adjustment lever.

To tilt the passenger's seat-back out of the way, push forward on the release lever at the base of the seat-back.

*On HX and EX models in the U.S., and Si model in Canada*

Push the passenger's seat-back while pushing the release lever to tilt the seat-back out of the way. The entire seat will slide forward at the same time.

## Head Restraints

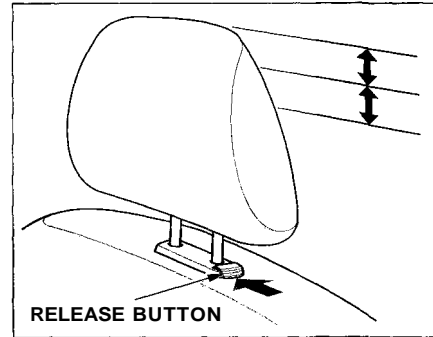

The front head restraints help protect you and your passenger from whiplash and other injuries. They are most effective when you adjust them so the top of the restraint is even with the top of your ears.

*CONTINUED*

## Seat Adjustments, Folding Rear Seat

The front head restraints adjust for height. You need both hands to adjust the restraint. Do not attempt to adjust it while driving. To raise it, pull upward. To lower the restraint, push the release button sideways and push the restraint down.

To remove a head restraint for cleaning or repair, pull it up as far as it will go. Push the release button and pull the restraint out of the seat-back.

Driving your car without head restraints can lead to serious injury to you and your passenger in a crash.

Make sure the head restraints are in place and adjusted properly before driving.

### Folding Rear Seat

The back of the rear seat folds down to give you direct access to the trunk. Each side folds down separately. With only half the seat folded, you can still carry a passenger in the back seat.

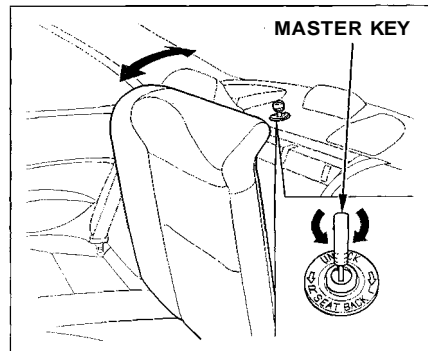

To fold down either side of the seat-back from inside the car, use the master key in the lock on the rear shelf. To fold down the driver's side, turn the key clockwise, fold down the seat-back, then release the key. To fold down the passenger's side, turn the key counterclockwise and perform the same procedure.

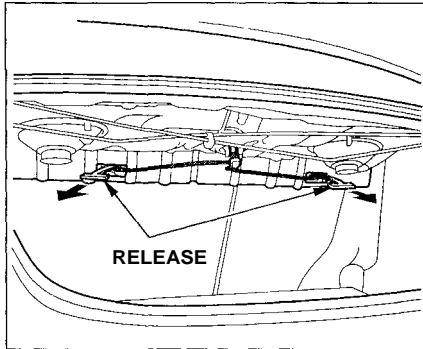

To release the seat-back from inside the trunk, pull the release under the rear shelf. Push the seat-back down, then let go of the release.

To lock the seat-back upright, push it firmly against the rear shelf. Make sure it is latched in place by pulling on the top of the seat.

Make sure all items in the trunk, or items extending through the opening into the back seat, are tied down. Loose items can fly forward and cause injury if you have to brake hard. See **Loading Cargo** on page 98.

Never drive with the seat-back folded down and the trunk lid open. See **Carbon Monoxide Hazard** on page 28.

### Power Windows

*On HX and EX models in the U.S., and Si model in Canada*

Your car's windows are electrically-powered. Turn the ignition switch to ON (II) to raise or lower any window.

Each door has a switch that controls its window. To open the window, push the switch down and hold it. Release the switch when you want the window to stop. Close the window by pulling back on the switch and holding it.

CONTINUED

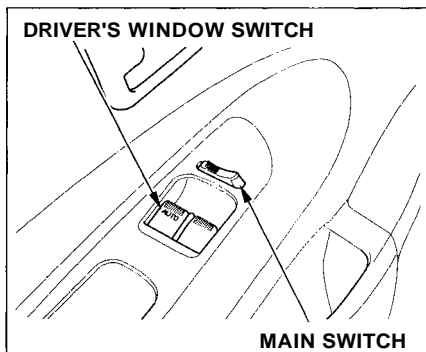

The driver's door has a master power window control panel. To open the passenger's window, push down on the switch and hold it down until the window reaches the desired position. To close the window, push up on the window switch. Release the switch when the window gets to the position you want.

Closing a power window on a child's hands or fingers can cause serious injury.

Make sure your children are away from the windows before closing them.

The master control panel also contains these extra features:

**AUTO** — To open the driver's window fully, push the window switch firmly down and release it. The window automatically goes all the way down. To stop the window from going all the way down, pull back on the window switch briefly.

To open the driver's window only partially, push the window switch down lightly and hold it. The window will stop as soon as you release the switch.

The AUTO function only works to lower the driver's window. To raise the window, you must pull back on the window switch and hold it until the window reaches the desired position.

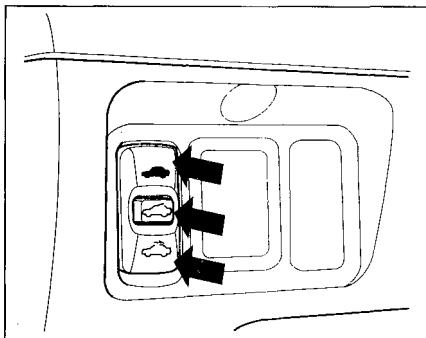

The MAIN switch controls power to the passenger's window. With this switch off, the passenger's window cannot be raised or lowered. The MAIN switch does not affect the driver's window. Keep the MAIN switch off when you have children in the car so they do not injure themselves by operating the window unintentionally.

## Moonroof



On EX model in the U.S., and Si model in Canada

Use the switches on the dashboard under the left vent to operate the moonroof. The ignition must be ON (II).

To lift the rear of the moonroof for ventilation, push the  button. To slide the moonroof back, push the  switch. Hold it until the moonroof reaches the desired

position, then release the switch. To close the moonroof, press and hold the  switch.

Closing the moonroof on someone's hands or fingers can cause serious injury.

Make sure passengers are clear of the moonroof before closing it.

## NOTICE

*If you try to open the moonroof in below-freezing temperatures, or when it is covered with snow or ice, you can damage the moonroof panel or motor.*

## Mirrors

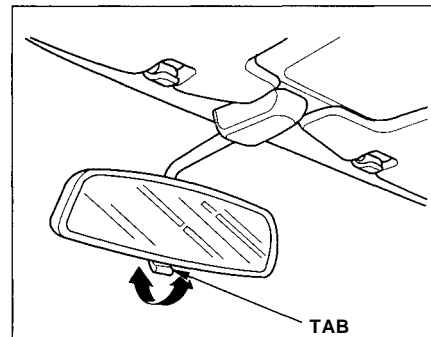

Keep the inside and outside mirrors clean and adjusted for best visibility. Be sure to adjust the mirrors before you start driving.

The inside mirror has day and night positions. The night position reduces glare from headlights behind you. Flip the tab on the bottom edge of the mirror to select the day or night position.

# Mirrors, Parking Brake

## Adjusting the Power Mirrors

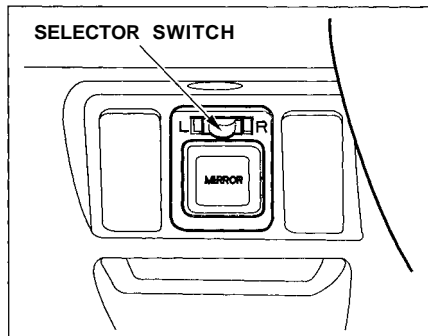

On HX and EX models in the U.S.. and Si model in Canada

Adjust the outside mirrors with the adjustment switch on the left side of the dashboard:

1. Turn the ignition switch ON (II).
2. Move the selector switch to L (driver's side) or R (passenger's side).

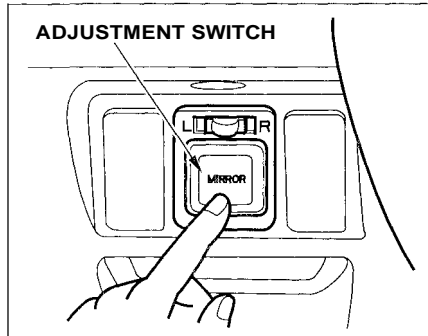

3. Push the appropriate edge of the adjustment switch to move the mirror right, left, up or down.
4. When you finish, move the selector switch to the center (off) position. This turns off the adjustment switch so you can't move a mirror out of position by accidentally bumping the switch.

## Parking Brake

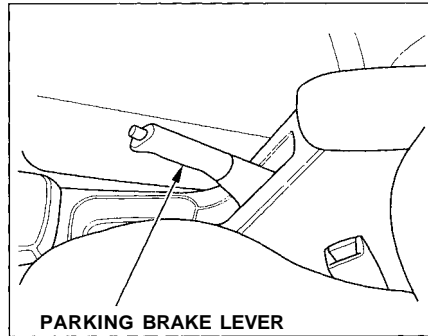

To apply the parking brake, pull the lever up fully. To release it, pull up slightly, push the button, and lower the lever. The parking brake light on the instrument panel should go out when the parking brake is fully released (see page 35).

### NOTICE

*Driving the car with the parking brake applied can damage the rear brakes and axles.*

### Glove Box

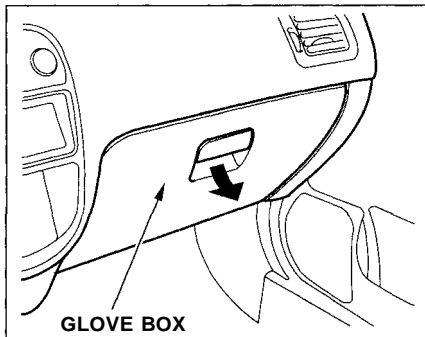

Open the glove box by pulling the handle. Close it with a firm push.

An open glove box can cause serious injury to your passenger in a crash, even if the passenger is wearing the seat belt.

Always keep the glove box closed while driving.

## Beverage Holder

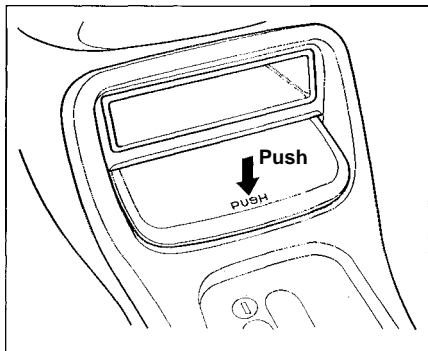

To open the beverage holder, push on the top. The beverage holder lid is spring-loaded and will swing open. To close it, push it down until it latches.

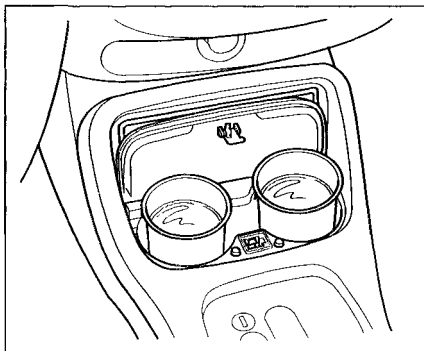

Use the beverage holder only when the car is parked. If you place cups in the holder while driving, the liquid may spill when you go over bumps or around corners.

Be careful when you are using the beverage holder. A spilled liquid that is very hot can scald you or your passengers. Spilled liquids can also damage the upholstery, carpeting, and electrical components in the interior.



### Accessory Power Socket

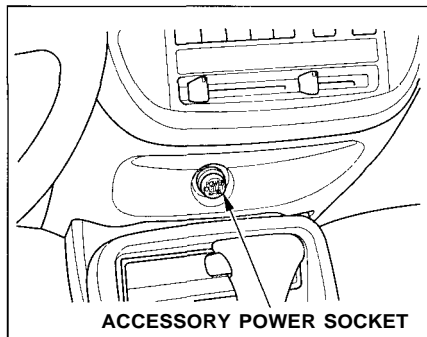

To use the accessory power socket, pull down the cover. The ignition switch must be in ACCESSORY (I) or ON (II).

This socket is intended to supply power for 12 volt DC accessories that are rated 120 watts or less (10 amps).

It will not power an automotive type cigarette lighter element.

### Ashtrays (Optional)

Front and rear ashtrays are available as options. The front ashtray fits in the beverage holder.

The rear ashtray fits in the rear of the center console.

Open the rear ashtray by swinging the upper edge down. To remove the ashtray for emptying, open the ashtray and then lift it up and out.

### NOTICE

*Use the ashtray only for cigarettes, cigars, and other smoking materials. To prevent a possible fire and damage to your car, don't put paper or other things that can burn in the ashtray.*

# Interior Light

(U.S.: EX, Canada: Si)

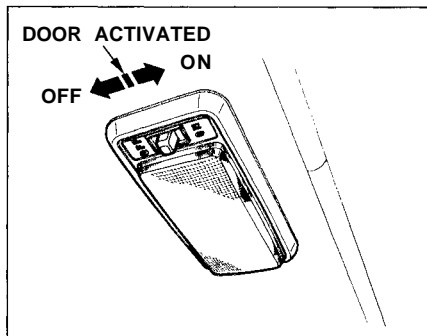

The interior light has a three-position switch. In the OFF position, the light does not come on. In the center position, the interior light comes on when you open any door. In the ON position, the interior light stays on continuously.

(U.S.: DX, HX, Canada: DX)

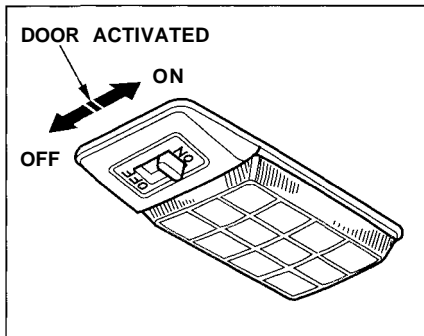

*On U.S. cars with remote transmitter*  
The interior light (with the switch in the center position) also comes on when you unlock the door with the remote transmitter (see page 52).

If you installed a non-Honda radio in your car, the interior light will no longer work.

The heating and air conditioning\* systems in your Honda provide a comfortable driving environment in all weather conditions.

The standard audio system has many features. This section describes those features and how to use them. (If you selected an optional audio system, refer to the operating instructions that came with it.)

\* Air conditioning is standard on the EX model in the U.S. It is optional on other models.

Heating and Cooling.....	68
What Each Control Does.....	68
How to Use the System.....	70
To Turn Everything Off.....	75
Audio System.....	76
Operating the Radio.....	76
Adjusting the Sound.....	78
Radio Frequencies.....	79
Radio Reception.....	79
Digital Clock.....	81
Operating the Cassette Player...	82
Tape Search Functions.....	82
Caring for the Cassette Player...	84
Operating the Optional CD Player/Changer.....	85
Protecting Compact Discs.....	87
CD Changer Error Indications...	88

# Heating and Cooling

Proper use of the Heating and Cooling system can make the interior dry and comfortable, and keep the windows clear for best visibility.

If your vehicle does not have air conditioning, it can be installed at any time. Your dealer will install a Genuine Honda air conditioning system that meets Honda's high quality standards and is designed to exactly fit your vehicle. Please contact your dealer for more information.

## What Each Control Does

### Fan Control Lever

Sliding this lever to the right increases the fan's speed, which increases air flow.

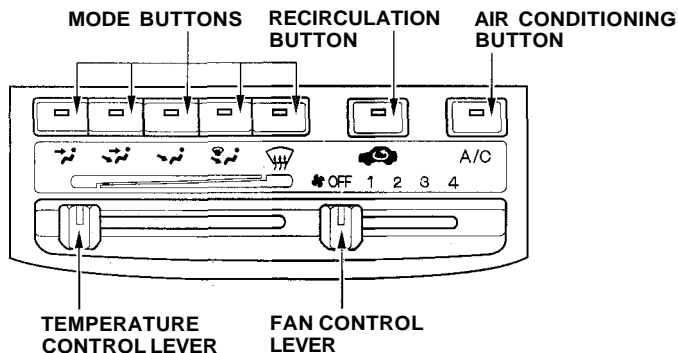

### Temperature Control Lever

Sliding this lever to the right increases the temperature of the air flow.

### Air Conditioning (A/C) Button

This button turns the air conditioning ON and OFF. The indicator in the button lights when the A/C is on.

### Recirculation Button

This button controls the source of the air going into the system. When the indicator in this button is lit, air from the vehicle's interior is sent through the system again (Recirculation mode). When the indicator is off, air is brought in from outside the vehicle (Fresh Air mode).

## Mode Buttons

Use the MODE buttons to select the vents the air flows from.

 Air flows from the center and corner vents in the dashboard.

 Air flow is divided between the vents in the dashboard and the floor vents.

 Air flows from the floor vents.

 Air flow is divided between the floor vents and the defroster vents at the base of the windshield.

 Air flows from the defroster vents at the base of the windshield.

When you select  , the system automatically switches to Fresh Air mode and turns on the A/C.

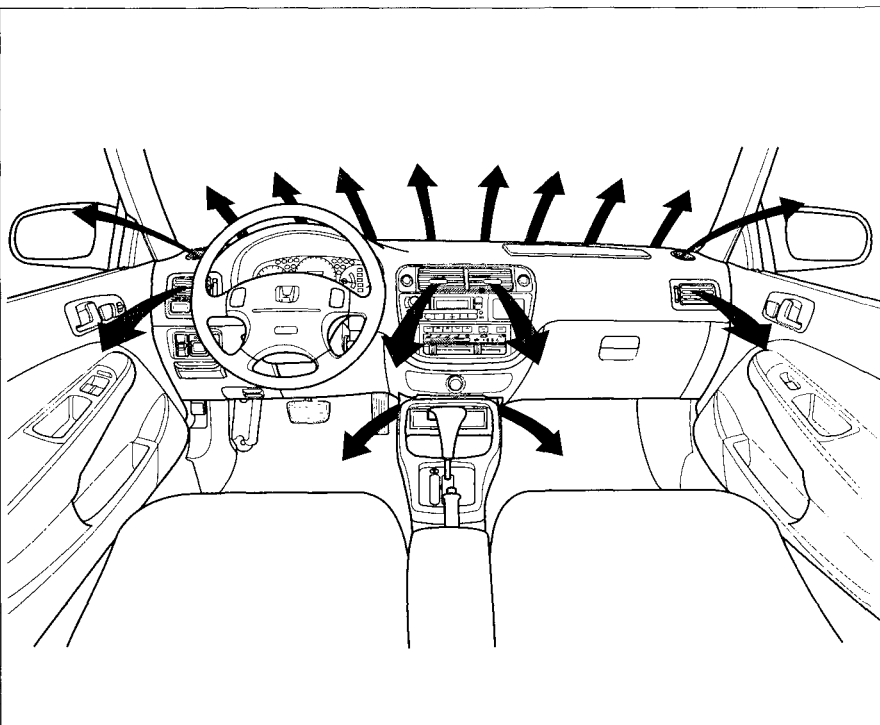

# Heating and Cooling

## Vent Controls

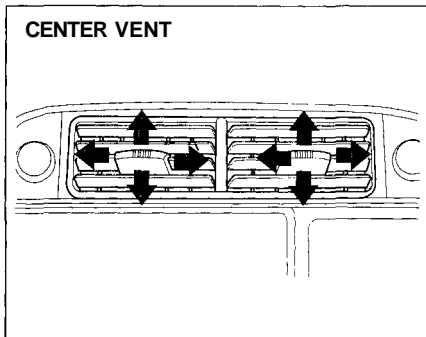

You can adjust the direction of the air coming from the dashboard vents by moving the tab in the center of each vent up-and-down and side-to-side.

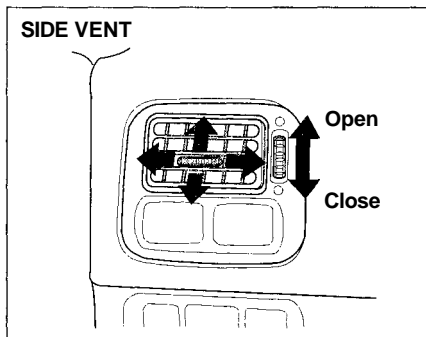

The vents in the corners of the dashboard can be opened and closed with the dials next to them.

## How to Use the System

This section covers how to set up the system controls for ventilation, heating, cooling, dehumidifying, and defrosting.

The engine must be running for the heater and air conditioning to generate hot and cold air. The heater uses engine coolant to warm the air. If the engine is cold, it will be several minutes before you feel warm air coming from the system. The air conditioning does not rely on engine temperature.

It is best to leave the system in Fresh Air mode under almost all conditions. Keeping the system in Recirculation mode, particularly with the A/C off, can cause the windows to fog up. Switch to Recirculation mode when you are driving through smoky or dusty conditions, then switch back to Fresh Air mode when the condition clears.

The outside air intakes for the heating and cooling system are at the base of the windshield. Keep these clear of leaves and other debris.

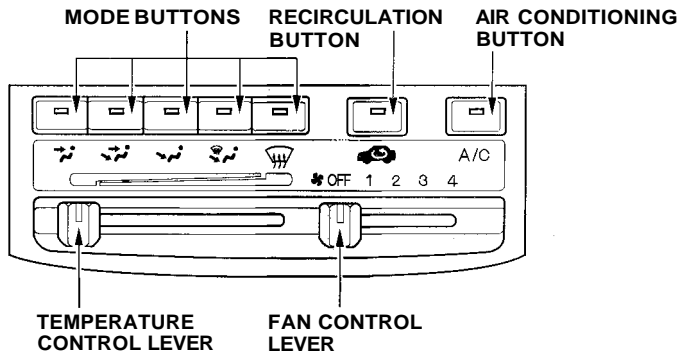

### ***Ventilation***

The flow-through ventilation system draws in outside air, circulates it through the interior, then exhausts it through vents near the rear window.

1. Slide the temperature control lever all the way to the left. Make sure the A/C is off.
2. Select  and Fresh Air mode.
3. Set the fan to the desired speed.

CONTINUED

# Heating and Cooling

## To Cool with A/C

1. Turn on the A/C by pressing the button. The light in the button should come on.
2. Make sure the temperature control lever is all the way to the left,
3. Select  and Fresh Air mode.
4. Set the fan to the desired speed.

If the interior is very warm from being parked in the sun, you can cool it down more rapidly by setting up the controls this way:

1. Start the engine.
2. Turn on the A/C by pressing the button. Make sure the temperature control lever is all the way to the left.
3. Set the fan to maximum speed.
4. Open the windows partially. Select  and Recirculation mode.

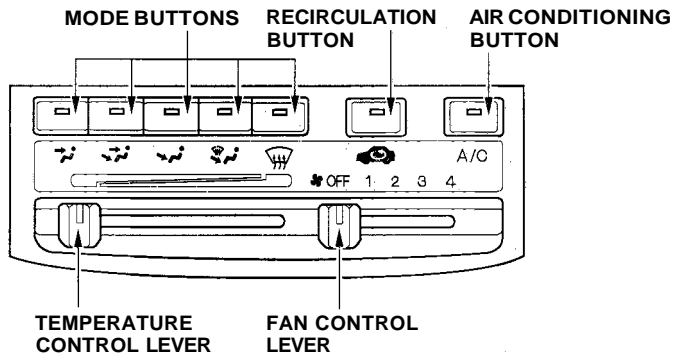

When the interior has cooled down to a more comfortable temperature, close the windows and set the controls as described for normal cooling.

Air conditioning places an extra load on the engine. Watch the engine coolant temperature gauge (see page 38) when driving in stop-and-go traffic or climbing a long, steep hill. If it moves near the red zone, turn off the A/C until the gauge reads normally.



## To Heat

To warm the interior:

1. Start the engine.
2. Select  and Fresh Air mode.
3. Set the fan to the desired speed.
4. Adjust the warmth of the air with the temperature control lever.

## To Heat and Dehumidify with Air Conditioning



Air conditioning, as it cools, removes moisture from the air. When used in combination with the heater, it makes the interior warm and dry.

1. Switch the fan on.
2. Turn on the air conditioning.
3. Select  and Fresh Air mode.
4. Adjust the temperature control lever so the mixture of heated and cooled air feels comfortable.

This setting is suitable for all driving conditions whenever the outside temperature is above 32°F (0°C).

## To Defog and Defrost

To remove fog from the inside of the windows:



1. Switch the fan on.
2. Select  .  
When you select  , the system automatically switches to Fresh Air mode and turns on the A/C.
3. Adjust the temperature control lever so the air flow from the defroster vents feels warm.
4. Turn on the rear window defogger to help clear the rear window.

When you switch to another mode from  , the A/C stays on. Press the A/C button to turn it off.

CONTINUED

## Heating and Cooling

To remove exterior frost or ice from the windshield and side windows after the car has been sitting out in cold weather:

1. Start the engine.
2. Select  .  
When you select  , the system automatically switches to Fresh Air mode and turns on the A/C.
3. Switch the fan and temperature controls to maximum.

To rapidly remove exterior frost or ice from the windshield (on very cold days), first select the Recirculation mode. Once the windshield is clear, select the Fresh Air mode to avoid fogging the windows.

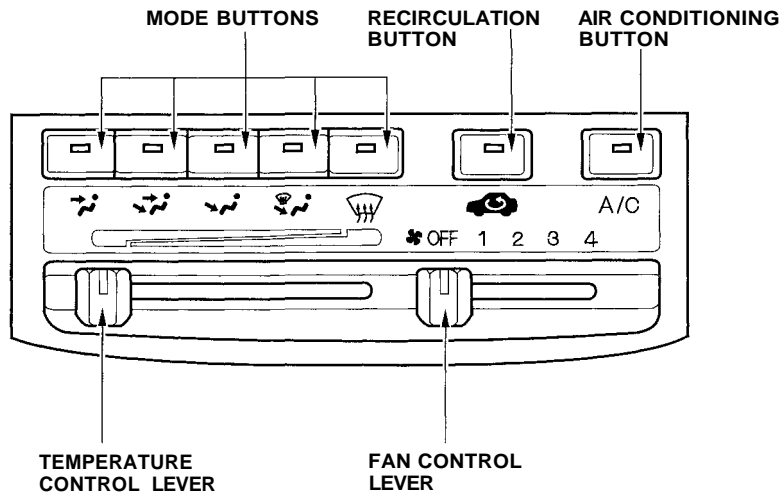

These settings direct all the air flow to the defroster vents at the base of the windshield and the side window defroster vents. The air flow will get warmer and clear the windows faster as the engine warms up. You can close the side vents with the dial beside each vent. This will send more warm air to the windshield defroster vents.

For safety, make sure you have a clear view through all the windows before driving away.

### **To Turn Everything Off**

To shut off the system temporarily, slide the fan speed and temperature control levers all the way to the left.

You should shut the system completely off only for the first few minutes of driving in cold weather, until the engine coolant warms up enough to operate the heater. Keep the fan on at all other times so stale air does not build up in the interior.

## AM/FM Stereo Audio System

Your Honda's audio system provides clear reception on both AM and FM bands, while the preset buttons allow you to easily select your favorite stations.

A cassette player, CD player or CD changer is available as optional equipment. The cassette player is standard on the Si model in Canada.

## Operating the Radio

The ignition switch must be in ACCESSORY (I) or ON (II) to operate the audio system. Turn the system on by pressing the PWR/VOL knob or the AM/FM button. Adjust the volume by turning the knob.

The band and frequency that the radio was last tuned to is displayed. To change bands, press the AM/FM button. On the FM band, ST will be displayed if the station is broadcasting in stereo. Stereo reproduction on AM is not available.

You can use any of three methods to find radio stations on the selected band: TUNE, SEEK, or the Preset buttons.

**TUNE** — Use the TUNE/SEEK bar to tune the radio to a desired frequency. Press the right side ( ^ ) to tune to a higher frequency, or the

left side ( v ) to tune to a lower frequency. The frequency numbers will start to change rapidly. Release the bar when the display reaches the desired frequency. To change the frequency in small increments, press and release the TUNE/SEEK bar quickly.

**SEEK** — The SEEK function searches the band for a station with a strong signal. To activate it, press the TUNE/SEEK bar until you hear a beep, then release it. Depending on which side of the bar you press, the system scans upward or downward from the current frequency. It stops when it finds a station with a strong signal.

**Preset** — You can store the frequencies of your favorite radio stations in the six preset buttons. Each button will store one frequency on the AM band, and two on the FM band.

To store a frequency:

1. Select the desired band, AM or FM. FM1 and FM2 let you store two frequencies with each Preset button.
2. Use the TUNE or SEEK function to tune the radio to a desired station.
3. Pick the Preset button you want for that station. Press the button and hold it until you hear a beep.
4. Repeat steps 1 to 3 to store a total of six stations on AM and twelve on FM.

Once a station's frequency is stored, simply press and release the proper Preset button to tune to it. The preset frequencies will be lost if your vehicle's battery goes dead, is disconnected or the radio fuse is removed.

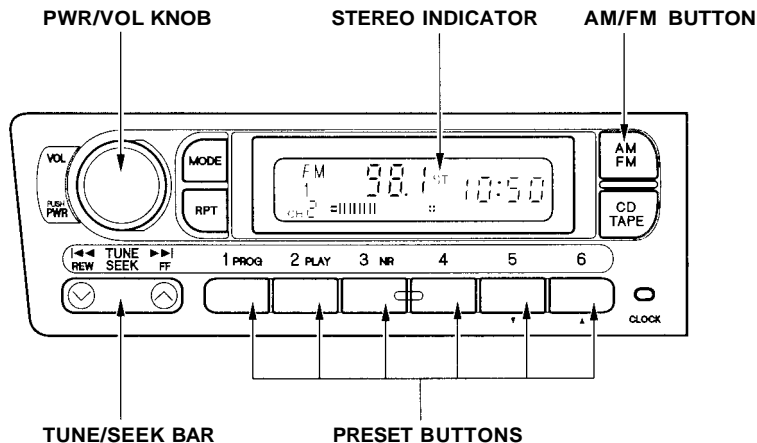

## Adjusting the Sound

Bass, Treble, Balance, and Fader are each adjustable. You select which of these you want to adjust by pressing the MODE button. The mode changes from BAS to TRE to FAD to BAL, and then back to VOL each time you press the button. Each mode is shown in the display as it changes.

**Balance/Fader** — These two modes adjust the strength of the sound coming from each speaker. BAL adjusts the side-to-side strength, while FAD adjusts the front-to-back strength.

Select BAL or FAD by pressing the MODE button. Adjust the Balance or Fader to your liking by turning the PWR/VOL knob. The indicator bars on the display show you the range.

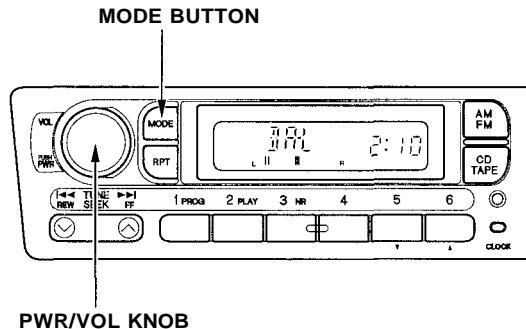

**Treble/Bass** — Use these modes to adjust the tone to your liking. Select TRE or BAS by pressing the MODE button. Adjust the desired mode by turning the PWR/VOL knob. The indicator bars on the display show you the range.

As you adjust a mode, you will hear a beep whenever the indicator bar reaches the center, far left, and far right of its range. The system will automatically return the display to normal mode about seven seconds after you stop adjusting a mode with the PWR/VOL knob.

## Radio Frequencies

Your Honda's radio can receive the complete AM and FM bands. Those bands cover these frequencies:

AM band:

530 to 1,710 kilohertz

FM band:

87.7 to 107.9 megahertz

Radio stations on the AM band are assigned frequencies at least ten kilohertz apart (530, 540, 550). Stations on the FM band are assigned frequencies at least 0.2 megahertz apart (87.9, 88.1, 88.3).

Stations must use these exact frequencies. It is fairly common for stations to round-off the frequency in their advertising, so your radio could display a frequency of 100.9 even though the announcer may identify the station as "FM101."

## Radio Reception

How well your Honda's radio receives stations is dependent on many factors, such as the distance from the station's transmitter, nearby large objects, and atmospheric conditions.

A radio station's signal gets weaker as you get farther away from its transmitter. If you are listening to an AM station, you will notice the sound volume becoming weaker, and the station drifting in and out. If you are listening to an FM station, you will see the stereo indicator flickering off and on as the signal weakens. Eventually, the stereo indicator will go off and the sound will fade completely as you get out of range of the station's signal.

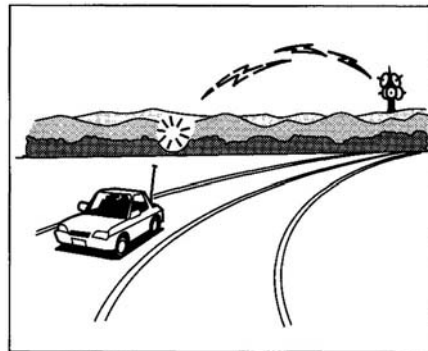

Driving very near the transmitter of a station that is broadcasting on a frequency close to the frequency of the station you are listening to can also affect your radio's reception. You may temporarily hear both stations, or hear only the station you are close to.

*CONTINUED*

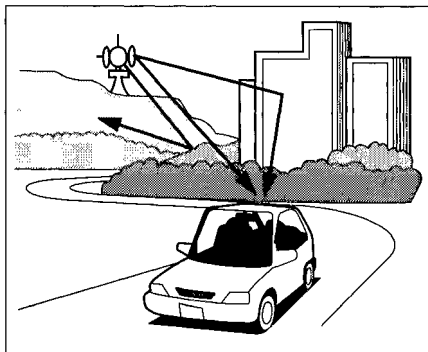

Radio signals, especially on the FM band, are deflected by large objects such as buildings and hills. Your radio then receives both the direct signal from the station's transmitter, and the deflected signal. This causes the sound to distort or flutter. This is a main cause of poor radio reception in city driving.



Radio reception can be affected by atmospheric conditions such as thunderstorms, high humidity, and even sunspots. You may be able to receive a distant radio station one day and not receive it the next day because of a change in conditions.

Electrical interference from passing vehicles and stationary sources can cause temporary reception problems.



## Digital Clock

The audio system also displays the time. The ignition switch must be in ACCESSORY (I) or ON (II).

To set the time, press the CLOCK button. The hour numbers will begin blinking. Press the Preset 5 button to get the numbers to count down, or the Preset 6 button to get the hours to count up.

Press the CLOCK button again, and the minutes numbers will begin blinking. Use the Preset 5 or Preset 6 button to change the minutes to the correct value.

After you have set the clock, press the CLOCK button again to return to the normal display. If you do not, the system will automatically return to the normal display about seven seconds after you stop pressing the Preset buttons.

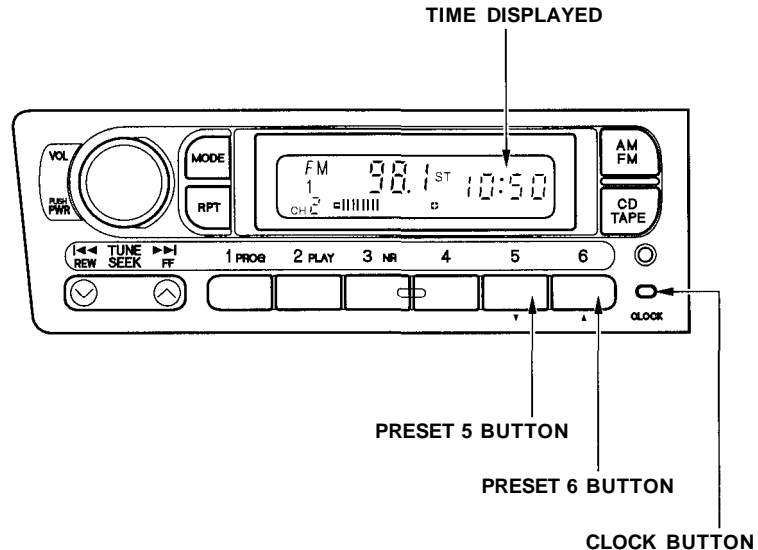

## Operating the Cassette Player

*Standard on Si model in Canada*

The cassette system features Dolby B\* noise reduction, automatic sensing of chromium-dioxide (CrO<sub>2</sub>) tape, and autoreverse for continuous play.

\* Dolby noise reduction manufactured under license from Dolby Laboratories Licensing Corporation. "DOLBY" and the double-D symbol  are trademarks of Dolby Laboratories Licensing Corporation.

Make sure the tape opening on the cassette is facing to the right, then insert the cassette most of the way into the slot. The system will pull it in the rest of the way, and begin to play.

The tape direction indicator will light to show you which side of the cassette is playing. The ▲ indicates the side you inserted facing upward is now playing. If you want to play

the other side, press the PROG button.

Dolby B noise reduction turns on when you insert a cassette. If the tape was not recorded with Dolby B noise reduction, turn it off by pressing the NR button.

When the system reaches the end of the tape, it will automatically reverse direction and play the other side. If you want to remove the cassette from the drive, press the EJECT button.

If you turn the system off while a tape is playing, either with the PWR/VOL knob or by turning off the ignition, the cassette will remain in the drive. When you turn the system back on, the tape will begin playing where it left off.

To switch to the radio or optional CD changer while listening to a tape,

press the AM/FM or CD/TAPE button. To change back to the cassette player, press the CD/TAPE button.

## Tape Search Functions

With a cassette playing, you can use the FF, REW, TMS, or REPEAT function to find a desired program.

**FF/REW** — Fast Forward and Rewind move the tape rapidly. Press and release the REW side of the TUNE/SEEK bar to rewind the tape, or the FF side to fast forward. Press the PLAY button to take the system out of rewind or fast forward. If the system reaches the end of the tape while in fast forward or rewind, it automatically stops that function, reverses direction, and begins to play.

**TMS** — The Tape Music Search function allows you to find the beginning of a song or passage. To activate TMS, press FF or REW until you hear a beep. You will see TMS displayed. When the system reaches the beginning of the next song or passage (FF), or the beginning of the song just played (REW), it goes back to PLAY mode.

**REPEAT** — The Repeat function continuously replays the current song or passage. Press the RPT button to activate it; you will see RPT displayed as a reminder. When the system reaches the end of the song or passage currently playing, it will automatically go into rewind. When it senses the beginning of the same song or passage, the system returns to PLAY mode. It will continue to repeat this same program until you deactivate REPEAT by pressing the button again.

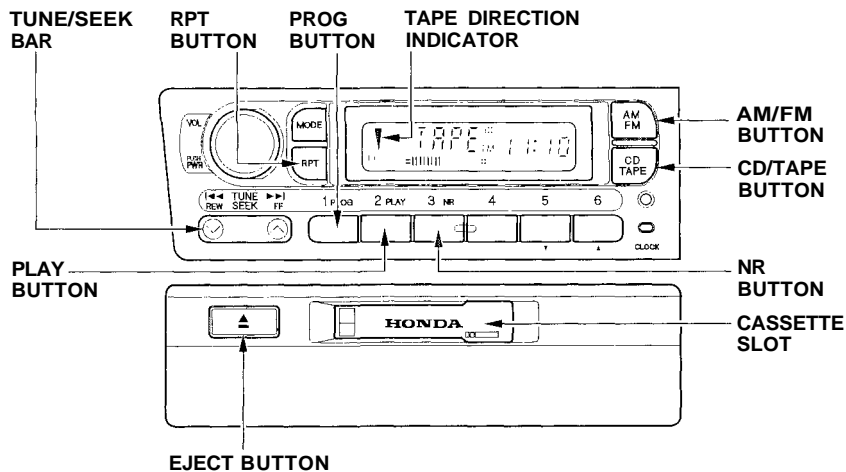

The TMS and REPEAT functions use silent periods on the tape to find the end of a song or passage. These features may not work to your satisfaction if there is almost no gap between selections, a high noise level between selections, or a silent period in the middle of a selection.

### Caring for the Cassette Player

The cassette player picks up dirt and oxides from the tape. This contamination builds up over time and causes the sound quality to degrade. To prevent this, you should clean the player after every 30 hours of use. Your dealer has a cleaning kit available.

If you do not clean the cassette player regularly, it may eventually become impossible to remove the contamination with a normal cleaning kit.

Use 100-minute or shorter cassettes. Cassettes longer than that use thinner tape that may break or jam the drive.

Look at the cassette before you insert it. If the tape is loose, tighten it by turning a hub with a pencil or your finger.

If the label is peeling off, remove it from the cassette or it could cause the cassette to jam in the player. Never try to insert a warped or damaged cassette in the player.

When they are not in use, store cassettes in their cases to protect them from dust and moisture. Never place cassettes where they will be exposed to direct sunlight, high heat, or high humidity. If a cassette is exposed to extreme heat or cold, let it reach a moderate temperature before inserting it in the player.

Never try to insert foreign objects into the cassette player.

If you see the error indication “**TAPER**” on the display, press the **EJECT** button and remove the cassette from the unit. Make sure the tape is not damaged. If the cassette will not eject or the error indication stays on after the cassette ejects, take the car to your Honda dealer.

If a problem develops in the connection between the cassette player and the radio, you will see “**TEEE**” in the display. Take the car to your Honda dealer.

## Operating the Optional CD Player/Changer

A Compact Disc changer is available through your dealer. It holds up to six discs, providing several hours of continuous entertainment. You operate the CD changer with the same controls used for the radio.

Your dealer also has an accessory in-dash single CD player available that is operated by the radio controls. To operate this unit, use the instructions (except for those relating to multiple discs) in this section.

To operate the CD player or changer, the ignition must be in ACCESSORY (I) or ON (II).

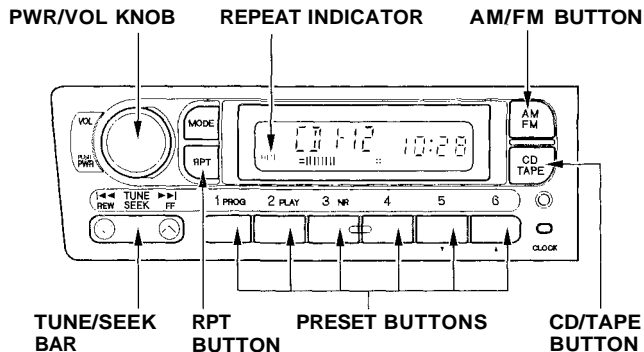

### CD Player

Insert the disc into the CD slot. Push the disc in halfway, the drive will pull it in the rest of the way. Push the CD/TAPE button and the disc will start to play.

You will see the track number being played in the display.

You can also play 3-inch (8-cm) discs without using an adapter ring.

When the system reaches the end of the disc, it will return to the beginning and play that disc again.

CONTINUED

Press the EJECT button to remove the disc from the player.

If you eject the disc, but do not remove it from the slot, the system will automatically reload the disc after 15 seconds and put the CD player in pause mode. To begin playing the disc, press the CD button.

### **CD Changer**

Using the instructions that came with the changer, load the desired CDs in the magazine, and load the magazine in the changer.

Press the CD/TAPE button. You will see "CD" in the display. The system will start to play the first track of the first disc. When that disc ends, the next disc in the magazine is loaded and played. After the last disc finishes, the system returns to disc 1.

To select a different disc, press the appropriate preset button (1 — 6). If you select an empty slot in the magazine, the changer will, after finding that slot empty, try to load the CD in the next slot. This continues until it finds a CD to load and play.

### **CD Player and Changer**

You can use the TUNE/SEEK bar to select tracks within a disc. If you press and release the TUNE/SEEK bar, the system will move to the beginning of a track. Press the ►► side to move to the beginning of the next track, and the ◀◀ side to move to the beginning of the current track.

If you press and hold the TUNE/SEEK bar, you will hear a beep and the system will continue to move across tracks. Release the bar when you think it has reached the desired place on the disc.

**REPEAT** — When you activate the Repeat feature by pressing the RPT button, the system continuously replays the current track. You will see RPT in the display as a reminder. Press the RPT button again to turn it off.

To take the system out of CD mode, press the AM/FM button or insert a cassette in the player. If a tape is already in the cassette player, press the CD/TAPE button. When you return to CD mode, play will continue at the same point that it left off.

If you turn the system off while a CD is playing, either with the PWR/VOL knob or the ignition switch, play will continue at the same point when you turn it back on.

## Protecting Compact Discs

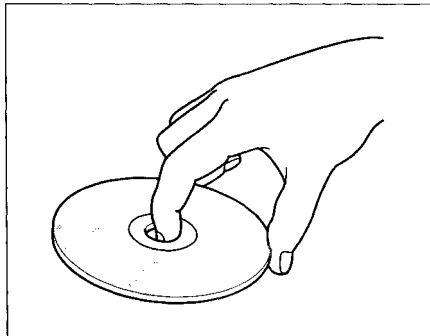

Handle a CD by its edges; never touch either surface. Contamination from fingerprints, liquids, felt-tip pens, and labels can cause the CD to not play properly, or possibly jam in the drive.

When a CD is not being played, store it in its case to protect it from dust and other contamination. To prevent warpage, keep CDs out of direct sunlight and extreme heat.

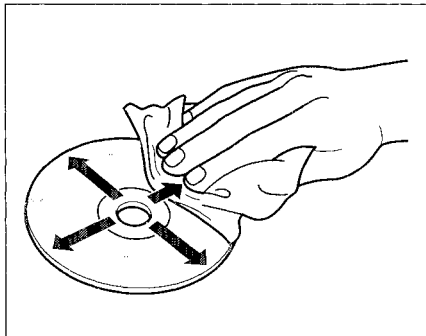

To clean a disc, use a clean soft cloth. Wipe across the disc from the center to the outside edge.

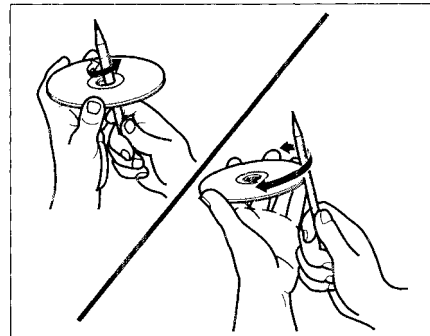

A new CD may be rough on the inner and outer edges. The small plastic pieces causing this roughness can flake off and fall on the re-recording surface of the disc, causing skipping or other problems. Remove these pieces by rubbing the inner and outer edges with the side of a pencil or pen.

Never try to insert foreign objects in the CD player or the magazine.

## CD Changer Error Indications

If you see an error indication in the display while operating the CD changer, find the cause in the chart to the right. If you cannot clear the error indication, take the car to your Honda dealer.

Indication	Cause	Solution
CD0000	No CD in the CD magazine	Insert CD.
CD---	No CD magazine in the CD changer	Insert CD magazine.
CD--H	High temperature	Will disappear when the temperature returns to normal.
CD EEE	Misconnection or disconnection of CD changer	See your Honda dealer.
CD E-1	Disc-changer malfunction	Consult your Honda dealer.
CD E-2	Disc is in changer mechanism	Press the magazine eject button, and insert an empty magazine.
CD E-3 CD E-4 CD E-5	Disc-changer malfunction	If the code disappears within a few seconds, unit is OK. If it does not, consult your Honda dealer.
CD E-6	Disc-changer malfunction	Press the magazine eject button and pull out the magazine, check for error indication. Insert the magazine again. If the magazine cannot be pulled out, consult your Honda dealer.
CD E-7	CD magazine ejection impossible	Press the magazine eject button. If the magazine does not eject, consult your Honda dealer.



Before you begin driving your Honda, you should know what gasoline to use, and how to check the levels of important fluids. You also need to know how to properly store luggage or packages. The information in this section will help you. If you plan to add any accessories to your car, please read the information in this section first.

Break-in Period.....	90
Gasoline.....	90
Oxygenated Fuels.....	90
Driving in Foreign Countries.....	91
Service Station Procedures .....	92
Filling the Fuel Tank.....	92
Opening the Hood.....	93
Oil Check.....	94
Engine Coolant Check.....	95
Fuel Economy.....	96
Vehicle Condition.....	96
Driving Habits.....	96
Accessories.....	97
Loading Cargo.....	98

### Break-in Period

Help assure your car's future reliability and performance by paying extra attention to how you drive during the first 600 miles (1,000 km). During this period:

- Avoid full-throttle starts and rapid acceleration.
- Avoid hard braking. New brakes need to be broken-in by moderate use for the first 200 miles (300 km).

You should follow these same recommendations with an overhauled or exchanged engine, or when the brakes are relined.

### Gasoline

Your Honda is designed to operate on unleaded gasoline with a pump octane number of 86 or higher. Use of a lower octane gasoline can cause a persistent, heavy metallic rapping noise in the engine that can lead to mechanical damage.

We recommend gasolines containing detergent additives that help prevent fuel system and engine deposits.

Using gasoline containing lead will damage your car's emission controls. This contributes to air pollution.

In Canada, some gasolines contain an octane-enhancing additive called MMT. If you use such gasolines, your emission control system performance may deteriorate and the Malfunction Indicator Lamp on your instrument panel may turn on. If this happens, contact your authorized Honda dealer for service.

### Oxygenated Fuels

Some conventional gasolines are being blended with alcohol or an ether compound. These gasolines are collectively referred to as oxygenated fuels. To meet clean air standards, some areas of the United States and Canada use oxygenated fuels to help reduce emissions.

If you use an oxygenated fuel, be sure it is unleaded and meets the minimum octane rating requirement.

Before using an oxygenated fuel, try to confirm the fuel's contents. Some states/provinces require this information to be posted on the pump.

The following are the EPA-approved percentages of oxygenates:

**ETHANOL** (ethyl or grain alcohol)

You may use gasoline containing up to 10 percent ethanol by volume.

Gasoline containing ethanol may be marketed under the name "Gasohol."

**MTBE** (Methyl Tertiary Butyl Ether)

You may use gasoline containing up to 15 percent MTBE by volume.

**METHANOL** (methyl or wood alcohol)

You may use gasoline containing up to 5 percent methanol by volume as long as it also contains cosolvents and corrosion inhibitors to protect the fuel system. Gasoline containing more than 5 percent methanol by volume may cause starting and/or performance problems. It may also damage metal, rubber and plastic parts of your fuel system.

If you notice any undesirable operating symptoms, try another service station or switch to another brand of gasoline.

Fuel system damage or performance problems resulting from the use of an oxygenated fuel containing more than the percentages of oxygenates given above are not covered under warranty.

***Driving in Foreign Countries***

If you are planning to take your Honda outside the U.S. or Canada, contact the tourist bureaus in the areas you will be traveling in to find out about the availability of unleaded gasoline with the proper octane rating.

If unleaded gasoline is not available, be aware that using leaded gasoline in your Honda will affect performance and fuel mileage, and damage its emissions controls. It will no longer comply with U.S. and Canadian emissions regulations, and will be illegal to operate in North America. To bring your car back into compliance will require the replacement of several components, such as the oxygen sensors and the three way catalytic converter. These replacements are not covered under warranty.

## Filling the Fuel Tank

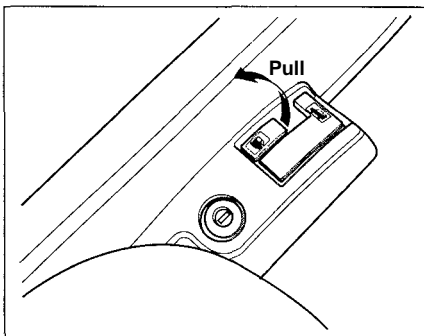

Gasoline is highly flammable and explosive. You can be burned or seriously injured when handling fuel.

- Stop the engine and keep heat, sparks, and flame away.
- Handle fuel only outdoors.
- Wipe up spills immediately.

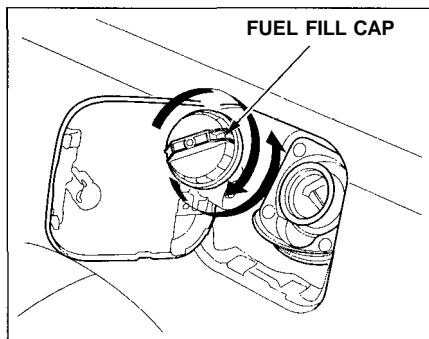

1. Because the fuel fill cap is on the driver's side of the car, park with that side closest to the service station pumps.
2. Open the fuel fill door by pulling on the handle to the left of the driver's seat.

3. Remove the fuel fill cap slowly. You may hear a hissing sound as pressure inside the tank escapes.
4. Stop filling the tank after the fuel pump automatically clicks off. Do not try to "top off" the tank, leave some room for the fuel to expand with temperature changes.
5. Screw the fuel fill cap back on, tighten it until it clicks. If you do not properly tighten the cap, the Malfunction Indicator Lamp may come on (see page [193](#)).
6. Push the fuel fill door closed until it latches.

## Opening the Hood

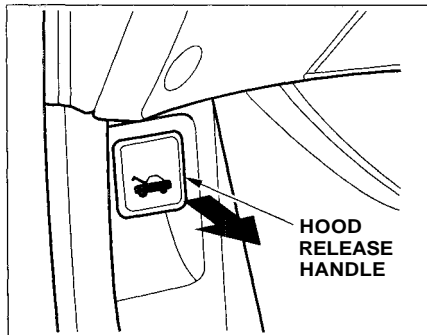

1. Shift to Park or Neutral and set the parking brake. Pull the hood release handle located under the lower left corner of the dashboard. The hood will pop up slightly.

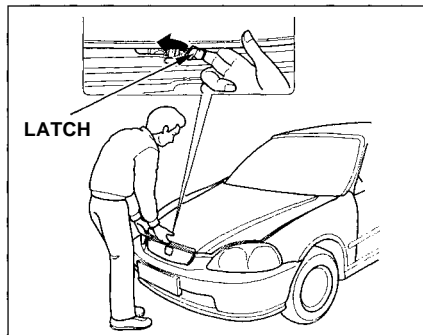

2. Standing in front of the car, put your fingers under the front edge of the hood to the right of center. Slide your hand to the left until you feel the hood latch handle. Push this handle to the left until it releases the hood. Lift the hood.

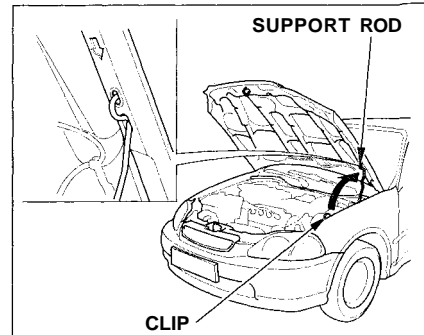

3. Pull the support rod out of its clip and insert the end into the hole on the left side of the hood.

To close the hood, lift it up slightly to remove the support rod from the hole. Put the support rod back into its holding clip. Lower the hood to about a foot above the fender, then let it drop.

*CONTINUED*

# Service Station Procedures

## Oil Check

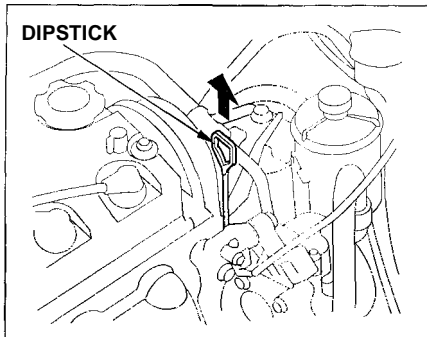

Check the engine oil level every time you fill the car with fuel. Wait at least two minutes after turning the engine off before you check the oil.

1. Remove the dipstick (orange handle).

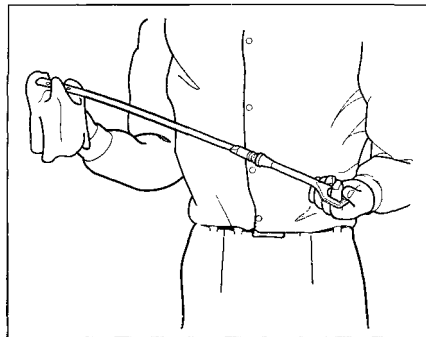

2. Wipe the dipstick with a clean cloth or paper towel.

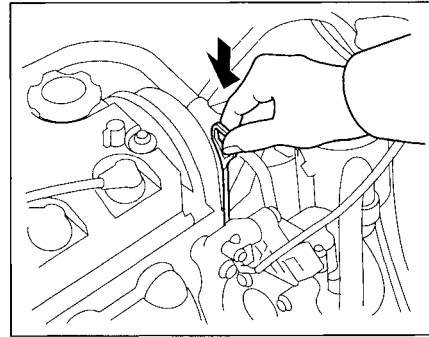

3. Insert it all the way back in its tube.

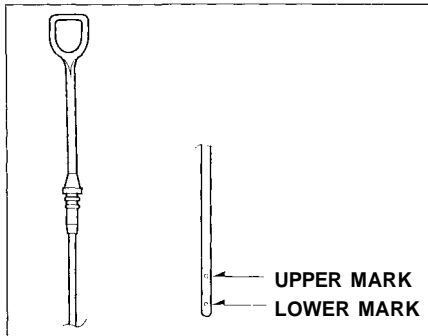

4. Remove the dipstick again and check the level. It should be between the upper and lower marks.

If it is near or below the lower mark, see **Adding Oil** on page [132](#).

## Engine Coolant Check

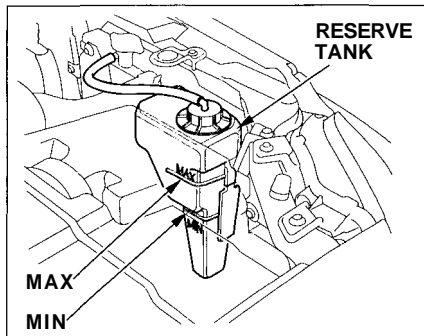

Look at the coolant level in the radiator reserve tank. Make sure it is between the MAX and MIN lines. If it is below the MIN line, **see Adding Engine Coolant** on page [136](#) for information on adding the proper coolant.

Refer to **Owner Maintenance Checks** on page [130](#) for information on checking other items in your Honda.

The condition of your car and your driving habits are the two most important things that affect the fuel mileage you get.

### Vehicle Condition

Always maintain your car according to the maintenance schedule. This will keep it in top operating condition.

An important part of that maintenance is the **Owner Maintenance Checks** (see page 130). For example, an underinflated tire causes more "rolling resistance," which uses fuel. It also wears out faster, so check the tire pressure at least monthly.

In winter, the build-up of snow on your car's underside adds weight and rolling resistance. Frequent cleaning helps your fuel mileage and reduces the chance of corrosion.

### Driving Habits

You can improve fuel economy by driving moderately. Rapid acceleration, abrupt cornering, and hard braking use more fuel.

Always drive in the highest gear practical for your speed and road conditions. Gain the best fuel economy by using the upshift indicator, if equipped, to direct your shifting during acceleration (see page 36).

Depending on traffic conditions, try to maintain a constant speed. Every time you slow down and speed up, your car uses extra fuel. Use the cruise control, when appropriate, to increase fuel economy.

A cold engine uses more fuel than a warm engine. It is not necessary to "warm-up" a cold engine by letting it idle for a long time. You can drive away in about a minute, no matter how cold it is outside. The engine will warm up faster, and you get better fuel economy. To cut down on the number of "cold starts," try to combine several short trips into one.

The air conditioning puts an extra load on the engine which makes it use more fuel. Turn off the A/C to cut down on air conditioning use. Use the flow-through ventilation when the outside air temperature is moderate.



Your Honda dealer has many Genuine Honda Accessories that allow you to personalize your car. These have all been approved for installation and use on your car, and are covered by warranty.

Some non-Honda accessories you can buy in the "aftermarket" are designed for universal applications. Although they may fit your Honda, they may not be within factory specifications. For example, aftermarket wheels may not meet Honda's specifications for width and offset. They could cause suspension problems that would not be covered by your warranty. Improperly-designed accessories can adversely affect your car's handling and stability.

Your car has several computer-controlled systems, including the SRS system, the engine's fuel injection, and the Anti-lock brake system. Strong electronic interference can affect their operation.

Electronic communications equipment, such as cellular telephones and two-way radios are regulated by the FCC (DOC in Canada) and should not interfere with your car's systems. Improper installation, or using electrical equipment not intended for mobile use may interfere with your car's operation. If you want to install a cellular telephone, other mobile communications equipment or even add-on stereo amplifiers, please discuss it first with your Honda dealer.

In many cases, improper installation is the real cause of problems with aftermarket accessories. Have these accessories installed by qualified technicians who are familiar with your Honda. If possible, have your Honda dealer inspect the final installation.

## Loading Cargo

---

The maximum load you can carry in your Honda is 850 lbs (395 kg). It includes the total weight of all passengers, their belongings and any accessories. This 850 lbs (395 kg) figure is shown as the Vehicle Capacity Weight on the tire information label attached to the driver's doorjamb.

To figure out how much cargo you can carry:

- Figure the total "occupant weight" you will be transporting. To do this, multiply the number of people (driver and all passengers) by 150 lbs (70 kg).
- Subtract this number from the Vehicle Capacity Weight (850 lbs/395 kg).

This final number is the total weight of cargo you can load in or on the car. With five occupants (driver and four passengers), the maximum recommended weight for cargo is 100 lbs (45 kg).

Where you store this cargo, and how well you secure it, are just as important as how much it weighs. Make sure you load cargo so it will not shift while driving. Items stored in the cargo area should be stored as far forward as possible.

You could store additional items on the floor behind the front seats. Make sure they cannot roll under the front seat and interfere with the pedals.

If you must carry large objects that prevent you from closing the trunk lid, be aware that exhaust gas can enter the interior. See **Carbon Monoxide Hazard** on page 28.

Never place items on the shelf behind the back seat. Those items can fly forward and injure you or your passengers if you brake hard or are involved in a collision.

This section gives you tips on starting the engine under various conditions, and how to operate the 5-speed manual and automatic transmissions. It also includes important information on parking your car, and the braking system.

Preparing to Drive.....	100
Starting the Engine.....	101
Starting in Cold Weather at High Altitude .....	101
5-speed Manual Transmission.....	102
Recommended Shift Points.....	102
Maximum Speeds.....	103
Automatic Transmission.....	104
Shift Lever Position Indicator..	104
Shift Lever Positions.....	105
Maximum Speeds.....	107
Shift Lock Release.....	108
Continuously Variable Transmission (CVT).....	109
Parking.....	113
The Braking System.....	114
Brake Wear Indicators.....	114
Brake System Design.....	115
Anti-lock Brakes.....	115
Important Safety Reminders....	116
ABS Indicator.....	117
Driving in Bad Weather.....	118
Towing a Trailer.....	119

## Preparing to Drive

---

You should do the following checks and adjustments every day before you drive your car.

1. Make sure all windows, mirrors, and outside lights are clean and unobstructed. Remove frost, snow, or ice.
2. Check that the hood and trunk are fully closed.
3. Visually check the tires. If a tire looks low, use a gauge to check its pressure.
4. Check that any items you may be carrying with you inside are stored properly or fastened down securely.
5. Check the adjustment of the seat (see page 56).
6. Check the adjustment of the inside and outside mirrors (see page 61).
7. Check the adjustment of the steering wheel (see page 45).
8. Make sure the doors are securely closed and locked.
9. Fasten your seat belt. Check that your passengers have fastened their seat belts (see page 7).
10. Turn the ignition ON (II). Check the indicator lights in the instrument panel.
11. Start the engine (see page 101).
12. Check the gauges and indicator lights in the instrument panel (see page 33).

1. Apply the parking brake.
2. In cold weather, turn off all electrical accessories to reduce the drain on the battery.
3. *Manual Transmission:*  
Push the clutch pedal down all the way. START (III) does not function unless the clutch pedal is depressed.  
  
*Automatic Transmission (Including CVT):*  
Make sure the shift lever is in Park. Press on the brake pedal.
4. Without touching the accelerator pedal, turn the ignition key to the START (III) position. If the engine does not start right away, do not hold the key in START (III) for more than 15 seconds at a time. Pause for at least 10 seconds before trying again.

5. If the engine does not start within 15 seconds, or starts but stalls right away, repeat step 4 with the accelerator pedal pressed half-way down. If the engine starts, release pressure on the accelerator pedal so the engine does not race.
6. If the engine still does not start, press the accelerator pedal all the way down and hold it there while starting in order to clear flooding. As before, keep the ignition key in the START (III) position for no more than 15 seconds. Return to step 5 if the engine does not start. If it starts, lift your foot off the accelerator pedal so the engine does not race.

### **Starting in Cold Weather at High Altitude (Above 8,000 feet/ 2,400 meters)**

An engine is harder to start in cold weather. The thinner air found at high altitude above 8,000 feet (2,400

meters) adds to the problem. Use the following procedure:

1. Turn off all electrical accessories to reduce the drain on the battery.
2. Push the accelerator pedal half-way to the floor and hold it there while starting the engine. Do not hold the ignition key in START (III) for more than 15 seconds. When the engine starts, release the accelerator pedal gradually as the engine speeds up and smooths out.
3. If the engine fails to start in step 2, push the accelerator pedal to the floor and hold it there while you try to start the engine for no more than 15 seconds. If the engine does not start, return to step 2.

## 5-speed Manual Transmission

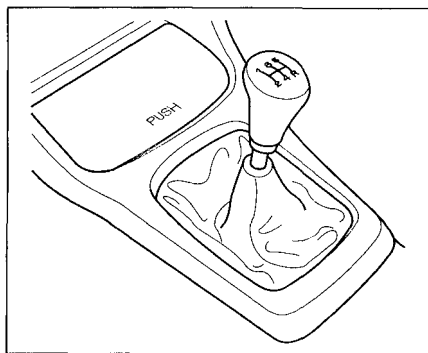

The manual transmission is synchronized in all forward gears for smooth operation. It has a lockout so you cannot shift directly from Fifth to Reverse. When shifting up or down, make sure you push the clutch pedal down all the way, shift to the next gear, and let the pedal up gradually. When you are not shifting, do not rest your foot on the clutch pedal. This can cause your clutch to wear out faster.

Come to a full stop before you shift into Reverse. You can damage the transmission by trying to shift into Reverse with the car moving. Push down the clutch pedal, and pause for a few seconds before shifting into Reverse, or shift into one of the forward gears for a moment. This stops the gears so they won't "grind".

When slowing down, you can get extra braking from the engine by shifting to a lower gear. This extra braking can help you maintain a safe speed and prevent your brakes from overheating while going down a steep hill. Before downshifting, make sure engine speed will not go into the tachometer's red zone in the lower gear. Refer to the Maximum Speeds chart.

Rapid slowing or speeding-up can cause loss of control on slippery surfaces. If you crash, you can be injured.

Use extra care when driving on slippery surfaces.

### Recommended Shift Points

Drive in the highest gear that lets the engine run and accelerate smoothly. This will give you the best fuel economy and effective emissions control. The following shift points are recommended:  
(U.S.: DX, EX, Canada: DX, Si)

Shift up	Normal acceleration
1st to 2nd	15 mph (24 km/h)
2nd to 3rd	27 mph (43 km/h)
3rd to 4th	39 mph (63 km/h)
4th to 5th	53 mph (85 km/h)

Shift up	Cruise from acceleration
1st to 2nd	9 mph (14 km/h)
2nd to 3rd	20 mph (32 km/h)
3rd to 4th	33 mph (53 km/h)
4th to 5th	48 mph (77 km/h)

The HX model has an Upshift Indicator (see page 36).

Use this indicator to help determine the shift points for best fuel economy.

Shift up	Normal acceleration
1st to 2nd	15 mph (24 km/h)
2nd to 3rd	25 mph (40 km/h)
3rd to 4th	40 mph (64 km/h)
4th to 5th	47 mph (76 km/h)

## Maximum Speeds

The speeds in this table are the maximums for the given gears. If you exceed these speeds, the engine speed will enter into the tachometer's red zone. If this occurs, you may feel the engine cut in and out. This is caused by a limiter in the engine's computer controls. The engine will run normally when you reduce the RPM below the red zone.

(DX)

Gear	Maximum speeds
1st	32 mph (52 km/h)
2nd	59 mph (95 km/h)
3rd	92 mph (148 km/h)
4th	118 mph (190 km/h)
5th	Top speed

(U.S.: EX, Canada: Si)

Gear	Maximum speeds
1st	32 mph (52 km/h)
2nd	53 mph (86 km/h)
3rd	82 mph (132 km/h)
4th	113 mph (182 km/h)
5th	Top speed

(HX)

Gear	Maximum speeds
1st	35 mph (56 km/h)
2nd	64 mph (103 km/h)
3rd	100 mph (161 km/h)
4th	Top speed
5th	Top speed

# Automatic Transmission

Your Honda's transmission has four forward speeds, and is electronically controlled for smoother shifting. It also has a "lock-up" torque converter for better fuel economy. You may feel what seems like another shift when the converter locks.

*On cars with Continuously Variable Transmission (CVT):*

To operate your Honda's Continuously Variable Transmission (CVT), refer to the page [109](#).

## Shift Lever Position Indicator

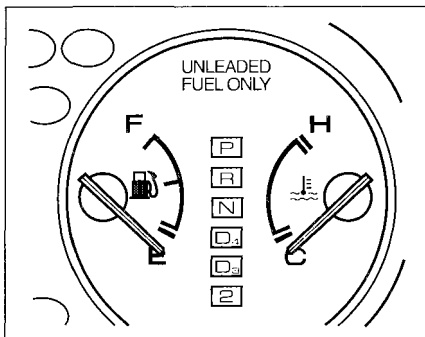

This indicator on the instrument panel shows which shift position the shift lever is in.

The "D<sub>4</sub>" indicator comes on for a few seconds when you turn the ignition switch ON (II). If it flashes while driving (in any shift position), it indicates a possible problem in the transmission. Avoid rapid acceleration and have the transmission checked by an authorized Honda

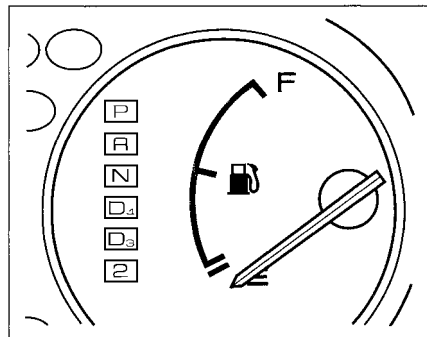

dealer as soon as possible.



## Shift Lever Positions

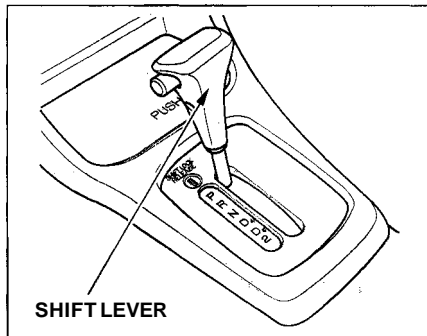

The shift lever has six positions. It must be in Park or Neutral to start the engine. When you are stopped in D<sub>4</sub>, D<sub>3</sub>, 2, N or R, press firmly on the brake pedal, and keep your foot off the accelerator pedal.

To shift from:	Do this:
P to R	Press the brake pedal and press the release button.
R to P N to R D <sub>3</sub> to 2	Press the release button.
2 to D <sub>3</sub> D <sub>3</sub> to D <sub>4</sub> D <sub>4</sub> to N D <sub>4</sub> to D <sub>3</sub> N to D <sub>4</sub> R to N	Move the lever.

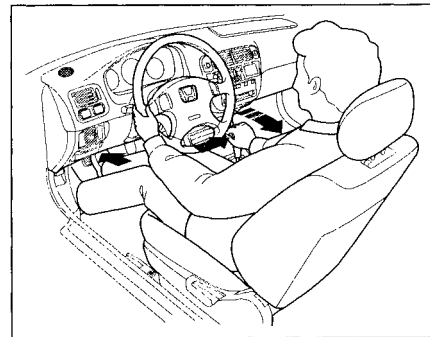

**Park (P)** — This position mechanically locks the transmission. Use Park whenever you are turning off or starting the engine. To shift out of Park, you must press on the brake pedal and have your foot off the accelerator pedal. Press the release button on the side of the shift lever to move it.

*CONTINUED*

If you have done all of the above and still cannot move the lever out of Park, see Shift Lock Release on page 108.

You must also press the release button to shift into Park. To avoid transmission damage, come to a complete stop before shifting into Park. The shift lever must be in Park before you can remove the key from the ignition switch.

**Reverse (R)** — To shift to Reverse from Park, see the explanation under Park. To shift to Reverse from Neutral, come to a complete stop and then shift. Press the release button before shifting into Reverse from Neutral.

**Neutral (N)** — Use Neutral if you need to restart a stalled engine, or if it is necessary to stop briefly with the engine idling. Shift to Park position if you need to leave the car for any reason. Press on the brake pedal when you are moving the shift lever from Neutral to another gear.

**Drive (D<sub>4</sub>)** — Use this position for your normal driving. The transmission automatically selects a suitable gear for your speed and acceleration. You may notice the transmission shifting up at higher speeds when the engine is cold. This helps the engine warm up faster.

**Drive (D<sub>3</sub>)** — This position is similar to D<sub>4</sub>, except only the first three gears are selected. Use D<sub>3</sub> to provide engine braking when going down a steep hill. D<sub>3</sub> can also keep the transmission from cycling between third and fourth gears in stop-and-go driving.

For faster acceleration when in D<sub>3</sub> or D<sub>4</sub>, you can get the transmission to automatically downshift by pushing the accelerator pedal to the floor. The transmission will shift down one or two gears, depending on your speed.

**Second (2)** — To shift to Second, press the release button on the side of the shift lever. This position locks the transmission in second gear. It does not downshift to first gear when you come to a stop. Second gives you more power when climbing, and increased engine braking when going down steep hills. Use second gear when starting out on a slippery surface or in deep snow. It will help reduce wheelspin.

Whenever you move the shift lever to a lower gear, the transmission downshifts only if the engine's redline will not be exceeded in the lower gear.

### Maximum Speeds

The speeds in this table are the maximums for the given position. If you exceed these speeds, the engine speed will enter into the tachometer's red zone. If this occurs, you will feel the engine cut in and out. This is caused by a limiter in the engine's computer controls. The engine will run normally when you reduce the RPM below the red zone.

(DX)

Position	Maximum speeds
2	68 mph (108 km/h)
D3	114 mph (182 km/h)
D4	Top speed

(U.S.: EX, Canada: Si)

Position	Maximum speeds
2	66 mph (106 km/h)
D3	109 mph (175 km/h)
D4	Top speed

# Automatic Transmission

## Shift Lock Release

This allows you to move the shift lever out of Park if the normal method of pushing on the brake pedal and pressing the release button does not work.

1. Set the Parking brake.
2. Remove the key from the ignition switch.

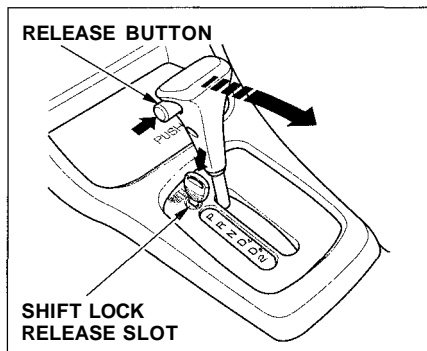

3. Insert the key in the Shift Lock Release slot next to the shift lever.
4. Push down on the key while you press the release button and move the shift lever out of Park to Neutral.

5. Remove the key from the Shift Lock Release slot. Depress the brake pedal and restart the engine.

If you need to use the Shift Lock Release, it means your car is developing a problem. Have the car checked by your Honda dealer.

## Continuously Variable Transmission (CVT)

*On HX model*

Honda's Continuously Variable automatic transmission's unique design provides a smooth, constant flow of power. It is electronically controlled for more precise operation and better fuel economy.

## Shift Lever Position Indicator

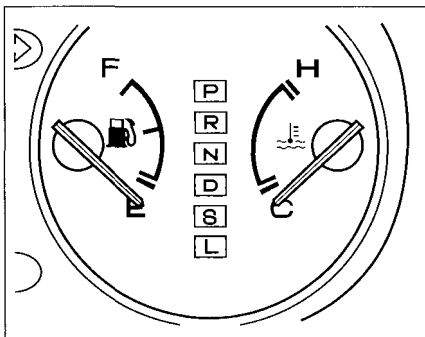

This indicator on the instrument panel shows which shift position the shift lever is in.

The "D" indicator comes on for a few seconds when you turn the ignition switch ON (II). If it flashes while driving (in any shift position), it indicates a possible problem in the transmission. Avoid rapid acceleration and have the transmission checked by an authorized Honda dealer as soon as possible.

## Shift Lever Positions

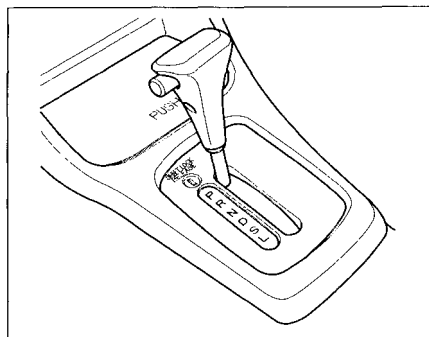

The shift lever has six positions. It must be in Park or Neutral to start the engine. When you are stopped in D, S, L, N or R, press firmly on the brake pedal and keep your foot off the accelerator pedal.

CONTINUED

# Automatic Transmission (CVT)

To shift from:	Do this:
P to R	Press the brake pedal and press the release button.
R to P N to R S to L	Press the release button.
S to D D to S D to N N to D R to N	Move the lever.

**Park (P)** — This position mechanically locks the transmission. Use Park whenever you are turning off or starting the engine. To shift out of Park, you must press on the brake pedal, have your foot off the accelerator pedal, and press the release button on the side of the shift lever. If you have done all of the above and still cannot move the lever out of Park, see Shift Lock Release on page [108](#).

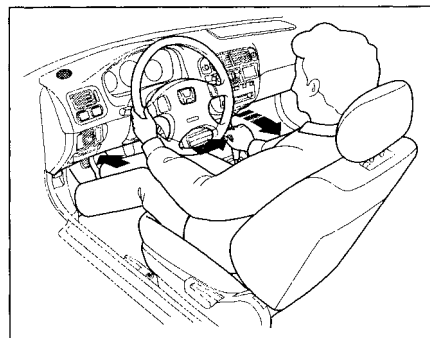

You must also press the release button to shift into Park. To avoid transmission damage, come to a complete stop before shifting into Park. The shift lever must be in Park before you can remove the key from the ignition switch.

**Reverse (R)** — To shift from Reverse to Park, see the explanation under Park. To shift to Reverse from Neutral, come to a complete stop first. Press the release button before shifting into Reverse from Neutral.

**Neutral (N)** — Use Neutral if you need to restart a stalled engine, or if it is necessary to stop briefly with the engine idling. Always shift to Park position if you need to leave the car for any reason. Press on the brake pedal when you are moving the shift lever from Neutral to another position.

**Drive (D)** — Use this position for your normal driving. The transmission automatically adjusts to keep the engine at the best speed for driving conditions. To help the engine warm up faster, the transmission will select ratios that allow the engine to run at higher speeds when it is cold.

**Second (S)** — Selecting Second shifts the transmission into a lower range of ratios for better acceleration and increased engine braking. Use Second when you are going down a steep hill, or in stop-and-go driving.

**Low (L)** — To shift to Low, press the release button on the side of the shift lever. Use Low to get more power when climbing, and for maximum engine braking when going down steep hills.

For faster acceleration when in D, S or L, the transmission will automatically "kick down" to a lower range of ratios by pushing the accelerator pedal to the floor.

## Automatic Transmission (CVT)

---

### Maximum Speeds

The CVT shifts automatically to maintain proper engine speed in any shift position.

When the vehicle reaches the maximum speed in any shift position, you may feel the engine cut in and out. This is caused by a limiter in the engine's computer controls. The engine will run normally when you reduce the speed below the maximum.



Always use the parking brake when you park your vehicle. The indicator on the instrument panel shows that the parking brake is not fully released; it does not indicate that the parking brake is firmly set. Make sure the parking brake is set firmly or your vehicle may roll if it is parked on an incline.

If your vehicle has an automatic transmission, set the parking brake before you put the transmission in Park. This keeps the vehicle from moving and putting pressure on the parking mechanism in the transmission — making it easier to move the shift lever out of Park when you want to drive away.

If the vehicle is facing uphill, turn the front wheels away from the curb. If you have a manual transmission, put it in first gear.

If the vehicle is facing downhill turn the front wheels toward the curb. If you have a manual transmission, put it in reverse gear.

Make sure the parking brake is fully released before driving away. Driving with the parking brake partially set can overheat or damage the rear brakes.

## Parking Tips

- Make sure the moonroof and the windows are closed.
- Turn off the lights.
- Place any packages, valuables, etc., in the trunk or take them with you.
- Lock the doors with the key or the remote transmitter.
- Never park over dry leaves, tall grass, or other flammable materials. The three way catalytic converter gets very hot, and could cause these materials to catch on fire.

# The Braking System

---

All Civics are equipped with front disc brakes. The brakes on the rear wheels are drum. A power assist helps reduce the effort needed on the brake pedal.

Put your foot on the brake pedal only when you intend to brake. Resting your foot on the pedal keeps the brakes applied lightly, causing them to build up heat. Heat build-up can reduce how well your brakes work. It also keeps your brake lights on all the time, confusing drivers behind you.

Constant application of the brakes when going down a long hill builds up heat and reduces their effectiveness. Use the engine to assist the brakes by downshifting to a lower gear and taking your foot off the accelerator pedal.

Check your brakes after driving through deep water. Apply the brakes moderately to see if they feel normal. If not, apply them gently and frequently until they do. Since a longer distance is needed to stop with wet brakes, be extra cautious and alert in your driving.

## **Brake Wear Indicators**

The front disc brakes on all cars have audible brake wear indicators. When the brake pads need replacing, you will hear a distinctive metallic "screeching" sound when you apply the brakes. If you do not have the brake pads replaced, they will begin screeching all the time.

Your brakes may sometimes squeal or squeak when you apply them lightly. Do not confuse this with the brake wear indicators. They make a very audible "screeching".

## Brake System Design

The hydraulic system that operates the brakes has two separate circuits. Each circuit works diagonally across the car (the left-front brake is connected with the right-rear brake, etc.). If one circuit should develop a problem, you will still have braking at two wheels.

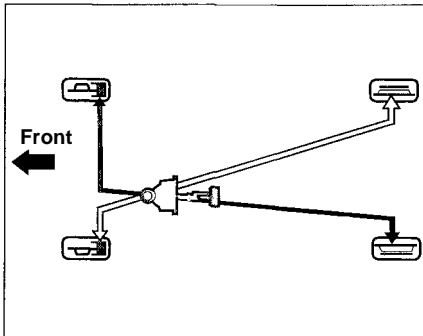

If this happens, you will immediately notice that the brake pedal goes down much farther and you need to press on it much harder. A much longer distance will be needed to stop the car.

Slow the car by downshifting to a lower gear and removing your foot from the accelerator pedal. Pull to the side of the road as soon as it is safe. Because of the longer stopping distance needed, brake system failure is very hazardous. You should have your car towed, but if you must drive the car in this condition, be extremely cautious. Have your car repaired as soon as possible.

## Anti-lock Brakes

Anti-lock brakes (ABS) is optional on the U.S. EX model with automatic transmission and all Canadian models.

ABS helps to prevent the wheels

from locking up and skidding during hard braking, allowing you to retain steering control.

When the front tires skid, you lose steering control; the car continues straight ahead even though you turn the steering wheel. The ABS helps to prevent lock-up and retain steering control by pumping the brakes rapidly; much faster than a person can do it.

**You should never pump the brake pedal,** this defeats the purpose of the ABS. Let the ABS work for you by always keeping firm, steady pressure on the brake pedal as you steer away from the hazard. This is sometimes referred to as *"stomp and steer."*

CONTINUED

# The Braking System

---

You will feel a pulsation in the brake pedal when the ABS activates, and you may hear some noise. This is normal, it is the ABS rapidly pumping the brakes.

Activation varies with the amount of traction your tires have. On dry pavement, you will need to press on the brake pedal very hard before you activate the ABS. However, you may feel the ABS activate immediately if you are trying to stop on snow or ice.

## *Important Safety Reminders*

**ABS does not reduce the time or distance it takes to stop the car**, it only helps with steering control during braking. You should always maintain a safe following distance from other vehicles.

**ABS will not prevent a skid that results from changing direction abruptly**, such as trying to take a corner too fast or making a sudden lane change. Always drive at a safe, prudent speed for the road and weather conditions.

**ABS cannot prevent a loss of stability**. Always steer moderately when you are braking hard. Severe or sharp steering wheel movement can still cause your vehicle to veer into oncoming traffic or off the road.

**A vehicle with ABS may require a longer distance to stop** on loose or uneven surfaces, such as gravel or snow, than a vehicle without anti-lock. Slow down and allow a greater distance between vehicles under those conditions.

## ABS Indicator

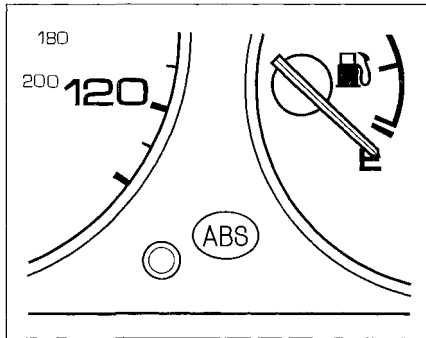

The ABS is self-checking. It also checks itself whenever you use the brakes.

If anything goes wrong, the ABS indicator on the instrument panel comes on (see page 35). This means the anti-lock function of the braking system has shut down. The brakes still work like a conventional system without anti-lock, providing normal stopping ability. You should have the

dealer inspect your vehicle as soon as possible if this light stays on after you start the engine, or comes on while driving.

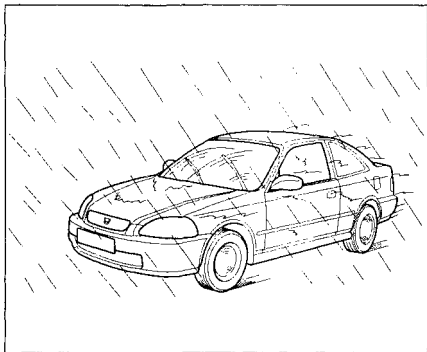

Rain, fog, and snow conditions require a different driving technique because of reduced traction and visibility. Keep your car well-maintained and exercise greater caution when you need to drive in bad weather. The cruise control should not be used in these conditions.

**Driving Technique** — Always drive slower than you would in dry weather. It takes your car longer to react, even in conditions that may seem just barely damp. Apply smooth, even pressure to all the controls. Abrupt steering wheel movements or sudden, hard application of the brakes can cause loss of control in wet weather. Be extra cautious for the first few miles (kilometers) of driving while you adjust to the change in driving conditions. This is especially true in snow. A person can forget some snow-driving techniques during the summer months. Practice is needed to relearn those skills.

Exercise extra caution when driving in rain after a long dry spell. After months of dry weather, the first rains bring oil to the surface of the roadway, making it slippery.

**Visibility** — Being able to see clearly in all directions and being visible to other drivers are important in all weather conditions. This is more difficult in bad weather. To be seen more clearly during daylight hours, turn on your headlights.

Inspect your windshield wipers and washers frequently. Keep the windshield washer reservoir full of the proper fluid. Have the windshield wiper blades replaced if they start to streak the windshield or leave parts unwiped. Use the defrosters and air conditioning to keep the windows from fogging up on the inside (see page [73](#)).

**Traction** — Check your tires frequently for wear and proper pressure. Both are important in preventing "hydroplaning" (loss of traction on a wet surface). In the winter, mount snow tires on all four wheels for the best handling.

Watch road conditions carefully, they can change from moment to moment. Wet leaves can be as slippery as ice. "Clear" roads can have patches of ice. Driving conditions can be very hazardous when the outside temperature is near freezing. The road surface can become covered with areas of water puddles mixed with areas of ice, so your traction can change without warning.

Be careful when downshifting. If traction is low, you can lock up the drive wheels for a moment and cause a skid.

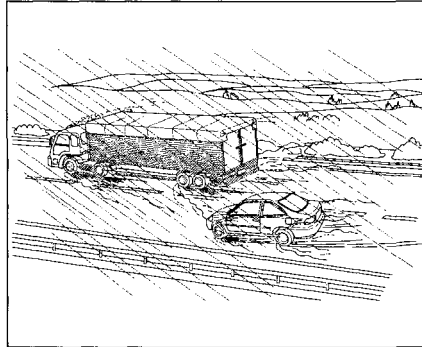

Be very cautious when passing, or being passed by, other vehicles. The spray from large vehicles reduces your visibility, and the wind buffeting can cause you to lose control.

### **Towing a Trailer**

Your car is not designed to tow a trailer. Attempting to do so can void your warranties.

This section explains why it is important to keep your car well maintained and to follow basic maintenance safety precautions.

This section also includes Maintenance Schedules for normal driving and severe driving conditions, a Maintenance Record, and instructions for simple maintenance tasks you may want to take care of yourself.

If you have the skills and tools to perform more complex maintenance tasks on your Honda, you may want to purchase the Service Manual. See page 219 for information on how to obtain a copy, or see your Honda dealer.

Maintenance Safety.....	122	Air Cleaner Element.....	146
Important Safety Precautions..	123	Spark Plugs.....	148
Maintenance Schedule.....	124	Replacement.....	148
Maintenance Record.....	128	Specifications.....	149
Owner Maintenance Checks.....	130	Battery.....	150
Fluid Locations.....	131	Windshield Wipers.....	152
Engine Oil.....	132	Air Conditioning System.....	154
Adding Oil.....	132	Drive Belts.....	155
Recommended Oil.....	132	Timing Belt.....	155
Synthetic Oil.....	133	Tires.....	156
Additives.....	133	Inflation.....	156
Changing the Oil and Filter.....	134	Recommended Tire Pressures	
Cooling System.....	136	for Normal Driving.....	157
Adding Engine Coolant.....	136	Inspection.....	158
Replacing Engine Coolant.....	138	Maintenance.....	158
Windshield Washers.....	141	Tire Rotation.....	159
Transmission Fluid.....	141	Replacing Tires and Wheels ...	159
Automatic		Wheels and Tires.....	160
Transmission.....	141	Winter Driving.....	160
5-speed Manual		Snow Tires.....	161
Transmission.....	143	Tire Chains.....	161
Brake and Clutch Fluid.....	143	Lights.....	162
Brake Fluid.....	144	Headlight Aiming.....	162
Brake System.....	144	Replacing Bulbs.....	164
Clutch System.....	144	Storing Your Car.....	172
Power Steering.....	145		



## Maintenance Safety

---

Regularly maintaining your car is the best way to protect your investment. Proper maintenance is essential to your safety and the safety of your passengers. It will also reward you with more economical, trouble-free driving and help reduce air pollution.

Improperly maintaining this car or failing to correct a problem before driving can cause a crash in which you can be seriously hurt or killed.

Always follow the inspection and maintenance recommendations and schedules in this owner's manual.

This section includes instructions for simple maintenance tasks, such as checking and adding oil. Any service items not detailed in this section should be performed by a Honda technician or other qualified mechanic.

Some of the most important safety precautions are given here. However, we cannot warn you of every conceivable hazard that can arise in performing maintenance. Only you can decide whether or not you should perform a given task.

Failure to properly follow maintenance instructions and precautions can cause you to be seriously hurt or killed.

Always follow the procedures and precautions in this owner's manual.

### **Important Safety Precautions**

Before you begin any maintenance, make sure your car is parked on level ground and that the parking brake is on. Also, be sure the engine is off. This will help to eliminate several potential hazards:

- **Carbon monoxide poisoning from engine exhaust.** Be sure there is adequate ventilation whenever you operate the engine.
- **Burns from hot parts.** Let the engine and exhaust system cool before touching any parts.
- **Injury from moving parts.** Do not run the engine unless instructed to do so.

Read the instructions before you begin, and make sure you have the tools and skills required.

To reduce the possibility of fire or explosion, be careful when working around gasoline or batteries. Use a nonflammable solvent, not gasoline, to clean parts. Keep cigarettes, sparks, and flames away from the battery and all fuel-related parts.

You should wear eye protection and protective clothing when working near the battery or when using compressed air.

# Maintenance Schedule

---

The Maintenance Schedule specifies how often you should have your car serviced and what things need attention. It is essential that you have your car serviced as scheduled to retain its high level of safety, dependability, and emission control performance.

The services and time or distance intervals shown in the maintenance schedule assume you will use your car as normal transportation for passengers and their possessions. You should also follow these recommendations:

- Avoid exceeding your car's load limit. This puts excess stress on the engine, brakes, and many other parts of your car. The load limit is shown on the label on the driver's doorjamb.
- Operate your car on reasonable roads within the legal speed limit.
- Drive your car regularly over a distance of several miles (kilometers).
- Always use unleaded gasoline with the proper octane rating (see page [90](#)).

## **Which Schedule to Follow:**

Service your car according to the time and mileage periods on one of the Maintenance Schedules on the following pages. Select the schedule for "Severe Conditions" if most of your driving is done under one or more of the conditions listed on that page. Otherwise, follow the schedule for "Normal Conditions."

Your authorized Honda dealer knows your car best and can provide competent, efficient service. However, service at a dealer is not mandatory to keep your warranties in effect. Maintenance may be done by any qualified service facility or person who is skilled in this type of automotive service. Keep all the receipts as proof of completion, and have the person who does the work fill out the Maintenance Record. Check your warranty booklet for more information.

We recommend the use of Genuine Honda parts and fluids whenever you have maintenance done. These are manufactured to the same high-quality standards as the original components, so you can be confident of their performance and durability.

U.S. Cars:

**Maintenance, replacement or repair of emission control devices and systems may be done by any automotive repair establishment or individual using parts that are "certified" to EPA standards.**

According to state and federal regulations, failure to perform maintenance on the items marked with an asterisk (\*) will not void your emissions warranties. However, Honda recommends that all maintenance services be performed at the recommended time or mileage period to ensure long-term reliability.

# Maintenance Schedule (Normal Conditions)

Service at the indicated distance or time -- whichever comes first.	miles x 1,000	15	30	45	60	75	90	105	120
	km x 1,000	24	48	72	96	120	144	168	192
	months	12	24	36	48	60	72	84	96
Replace engine oil	Replace every 7,500 miles (12,000 km) or 12 months								
Replace engine oil filter	•	•	•	•	•	•	•	•	•
Check engine oil and coolant	Check oil and coolant at each fuel stop								
Replace air cleaner element		•			•		•		•
Inspect valve clearance	At 30,000 miles (48,000 km) only								
Replace spark plugs		•			•		•		•
Replace timing belt and inspect water pump								•	
Inspect and adjust drive belts		•			•		•		•
Inspect idle speed								•	
Replace engine coolant			•			•		•	
Replace transmission fluid	MT/AT							•	
	CVT		•		•		•		•
Inspect front and rear brakes	•	•	•	•	•	•	•	•	•
Replace brake fluid			•				•		
Check parking brake adjustment	•	•	•	•	•	•	•	•	•
Rotate tires (Check tire inflation and condition at least once per month)	Rotate tires every 7,500 miles (12,000 km)								
Inspect Supplemental Restraint System	10 years after production								
<b>Visually inspect the following items:</b>									
Tie rod ends, steering gear box, and boots									
Suspension components									
Driveshaft boots									
Brake hoses and lines (including ABS)	•	•	•	•	•	•	•	•	•
All fluid levels and condition of fluids									
Cooling system hoses and connections									
Exhaust system*									
Fuel lines and connections*									

Follow the Normal Maintenance Schedule if the severe driving conditions specified in the Severe Conditions Maintenance Schedule on the next page do not apply.

**NOTE:** If you only *OCCASIONALLY* drive under a "severe" condition, you should follow the Normal Conditions Maintenance Schedule.

# Maintenance Schedule (Severe Conditions)

Service at the indicated distance or time - whichever comes first.	miles x 1,000	15	30	45	60	75	90	105	120
	km x 1,000	24	48	72	96	120	144	168	192
	months	12	24	36	48	60	72	84	96
Replace engine oil and oil filter	Replace every 3,750 miles (6,000 km) or 6 months								
Check engine oil and coolant	Check oil and coolant at each fuel stop								
Replace air cleaner element		•	•	•	•	•	•	•	•
Use normal schedule except in dusty conditions									
Inspect valve clearance	At 30,000 miles (48,000 km) only								
Replace spark plugs			•		•		•		•
Replace timing belt*1 and inspect water pump								•	
Inspect and adjust drive belts		•		•		•		•	
Inspect idle speed								•	
Replace engine coolant			•		•			•	
Replace transmission fluid	MT/AT		•		•		•		•
	CVT*2		•		•		•		•
Inspect front and rear brakes	Inspect every 7,500 miles (12,000 km) or 6 months								
Replace brake fluid				•			•		
Check parking brake adjustment	•	•	•	•	•	•	•	•	•
Lubricate locks and hinges	•	•	•	•	•	•	•	•	•
Clean antenna mast	•	•	•	•	•	•	•	•	•
Rotate tires (Check tire inflation and condition at least once per month)	Rotate tires every 7,500 miles (12,000 km)								
Inspect Supplemental Restraint System	10 years after production								
<b>Visually inspect the following items:</b>									
Tie rod ends, steering gear box, and boots Suspension components, Driveshaft boots	Every 7,500 miles (12,000 km) or 6 months								
Brake hoses and lines (including ABS) All fluid levels and condition of fluids Cooling system hoses and connections Exhaust system*, Fuel lines and connections Lights and controls, Vehicle underbody	•	•	•	•	•	•	•	•	•

Follow the Severe Maintenance Schedule if you drive your vehicle *MAINLY* under one or more of the following conditions:

- Driving less than 5 miles (8 km) per trip or, in freezing temperatures, driving less than 10 miles (16 km) per trip.
- Driving in hot [over 90°F (32°C)] conditions.
- Extensive idling or long periods of stop-and-go driving.
- Driving with a car-top carrier, or driving in mountainous conditions.
- Driving on muddy, dusty, or de-iced roads.

**For Canadian Owners**  
Follow the Maintenance Schedule for Severe Conditions.

\* 1 : Refer to page 155 for replacement information under special driving conditions.

\* 2 : Refer to page 142 for replacement information under special driving conditions.

# Required Maintenance Record

Have your servicing dealer record all Required Maintenance below. Keep receipts for all work done on your car.

<b>7,500 Mi.</b> 12,000 km (or 6 Mo.)	(Sign or Stamp)	Mi. (Km) ----- Date
<b>15,000 Mi.</b> 24,000 km (or 12 Mo.)	(Sign or Stamp)	Mi. (Km) ----- Date
<b>22,500 Mi.</b> 36,000 km (or 18 Mo.)	(Sign or Stamp)	Mi. (Km) ----- Date
<b>30,000 Mi.</b> 48,000 km (or 24 Mo.)	(Sign or Stamp)	Mi. (Km) ----- Date
<b>37,500 Mi.</b> 60,000 km (or 30 Mo.)	(Sign or Stamp)	Mi. (Km) ----- Date
<b>45,000 Mi.</b> 72,000 km (or 36 Mo.)	(Sign or Stamp)	Mi. (Km) ----- Date
<b>52,500 Mi.</b> 84,000 km (or 42 Mo.)	(Sign or Stamp)	Mi. (Km) ----- Date
<b>60,000 Mi.</b> 96,000 km (or 48 Mo.)	(Sign or Stamp)	Mi. (Km) ----- Date

<b>67,500 Mi.</b> 108,000 km (or 54 Mo.)	(Sign or Stamp)	Mi. (Km) ----- Date
<b>75,000 Mi.</b> 120,000 km (or 60 Mo.)	(Sign or Stamp)	Mi. (Km) ----- Date
<b>82,500 Mi.</b> 132,000 km (or 66 Mo.)	(Sign or Stamp)	Mi. (Km) ----- Date
<b>90,000 Mi.</b> 144,000 km (or 72 Mo.)	(Sign or Stamp)	Mi. (Km) ----- Date
<b>97,500 Mi.</b> 156,000 km (or 78 Mo.)	(Sign or Stamp)	Mi. (Km) ----- Date
<b>105,000 Mi.</b> 168,000 km (or 84 Mo.)	(Sign or Stamp)	Mi. (Km) ----- Date
<b>112,500 Mi.</b> 180,000 km (or 90 Mo.)	(Sign or Stamp)	Mi. (Km) ----- Date
<b>120,000 Mi.</b> 192,000 km (or 96 Mo.)	(Sign or Stamp)	Mi. (Km) ----- Date

# Non-Scheduled Maintenance Record

Record additional maintenance for severe driving conditions or non-scheduled maintenance on this page (see page [127](#)).

<b>Maintenance Performed:</b>	(Sign or Stamp)	Mi. (Km)
		Date
<b>Maintenance Performed:</b>	(Sign or Stamp)	Mi. (Km)
		Date
<b>Maintenance Performed:</b>	(Sign or Stamp)	Mi. (Km)
		Date
<b>Maintenance Performed:</b>	(Sign or Stamp)	Mi. (Km)
		Date
<b>Maintenance Performed:</b>	(Sign or Stamp)	Mi. (Km)
		Date
<b>Maintenance Performed:</b>	(Sign or Stamp)	Mi. (Km)
		Date
<b>Maintenance Performed:</b>	(Sign or Stamp)	Mi. (Km)
		Date

<b>Maintenance Performed:</b>	(Sign or Stamp)	Mi. (Km)
		Date
<b>Maintenance Performed:</b>	(Sign or Stamp)	Mi. (Km)
		Date
<b>Maintenance Performed:</b>	(Sign or Stamp)	Mi. (Km)
		Date
<b>Maintenance Performed:</b>	(Sign or Stamp)	Mi. (Km)
		Date
<b>Maintenance Performed:</b>	(Sign or Stamp)	Mi. (Km)
		Date
<b>Maintenance Performed:</b>	(Sign or Stamp)	Mi. (Km)
		Date
<b>Maintenance Performed:</b>	(Sign or Stamp)	Mi. (Km)
		Date



## Owner Maintenance Checks

---

You should check the following items at the specified intervals. If you are unsure of how to perform any check, turn to the page given.

- Engine oil level — Check every time you fill the fuel tank. See page [94](#).
- Engine coolant level — Check the radiator reserve tank every time you fill the fuel tank. See page [95](#).
- Windshield washer fluid — Check the level in the reservoir monthly. If weather conditions cause you to use the washers frequently, check the reservoir each time you stop for fuel. See page [141](#).
- Tires — Check the tire pressure monthly. Examine the tread for wear and foreign objects. See page [156](#).
- Lights — Check the operation of the headlights, parking lights, taillights, high-mount brake light, turn signals, brake lights, and license plate lights monthly. See page [162](#).

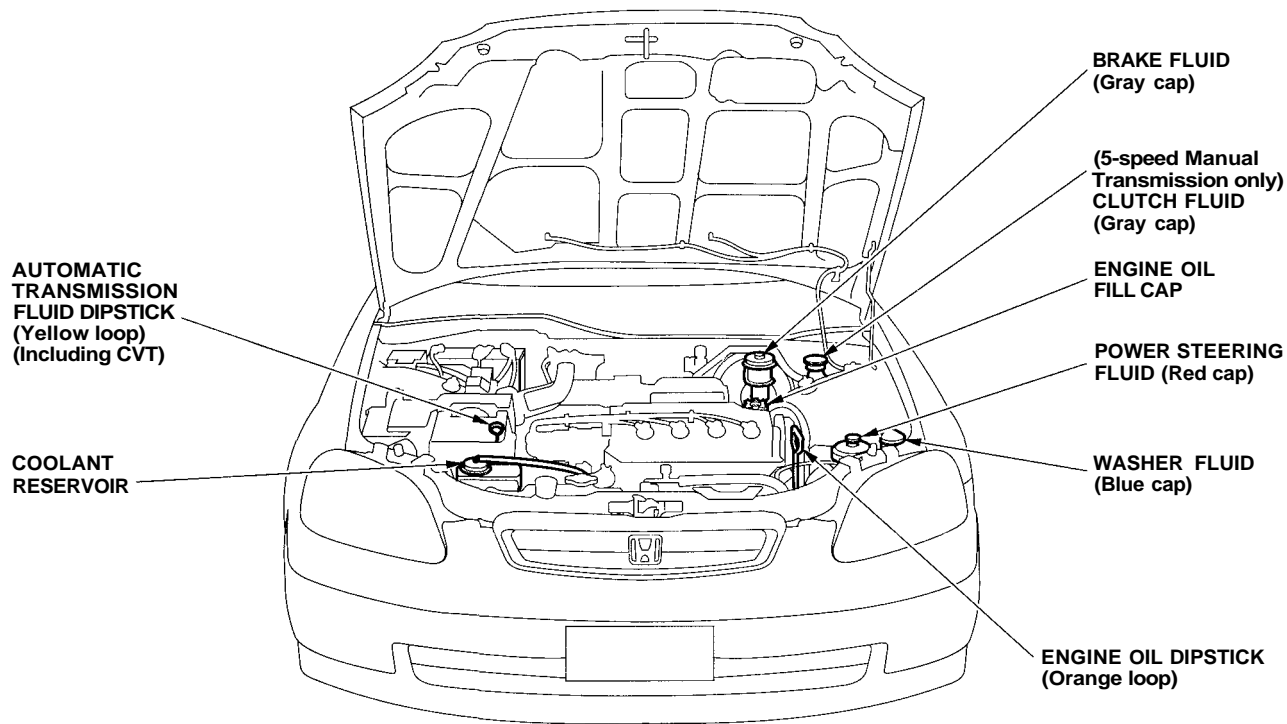

## Adding Oil

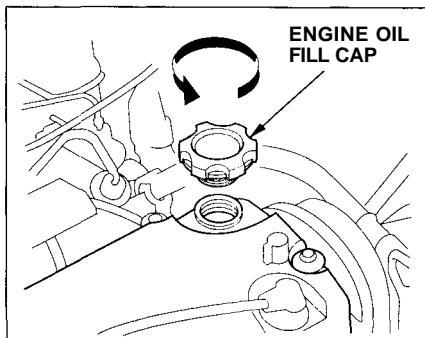

To add oil, unscrew and remove the engine oil fill cap on top of the valve cover. Pour in the oil, and replace the engine oil fill cap. Tighten it securely. Wait a few minutes and recheck the oil level. Do not fill above the upper mark; you could damage the engine.

## Recommended Oil

Oil is a major contributor to your engine's performance and longevity. Always use a premium-grade detergent oil.

You can determine an oil's SAE viscosity and Service Classification from the API Service label on the oil container.

A fuel-efficient oil is recommended for your Honda. This is shown on the API Service label by the words "Energy Conserving" or "Energy Conserving II." This oil is formulated to help your engine use less fuel.

The API Service label also tells you the service classification of the oil. Always use an oil that is labeled "API Service SJ" or "API Service SH." This service rating may include other classifications, such as CD. These additional classifications are not a problem, as long as the label also carries the SJ or SH classification. An oil that is only classified SG is not recommended.

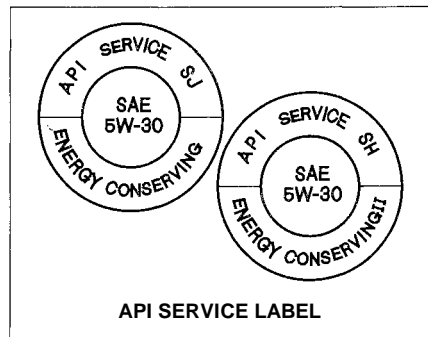

The oil container may also display the API Certification mark. Make sure it says "For Gasoline Engines."

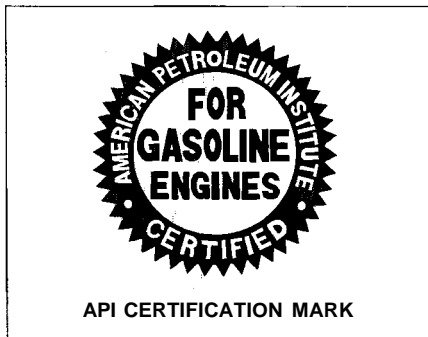

The SAE numbers tell you the oil's viscosity or weight. Select the oil for your car according to this chart.

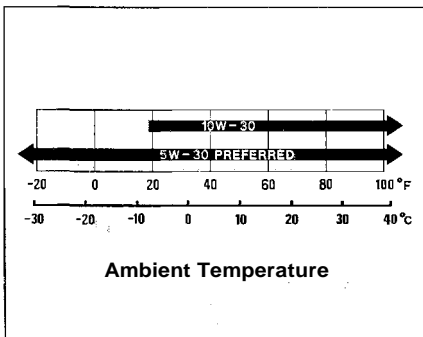

An oil with a viscosity of 5W-30 is preferred for improved fuel economy and year-round protection in your Honda. You may use a 10W-30 oil if the temperature in your area never goes below 20°F (— 7°C).

## Synthetic Oil

You may use a synthetic motor oil if it meets the same requirements given for conventional motor oil; energy conserving, a service classification of SJ or SH, and the proper weight as shown on the chart. When using synthetic oil, you must follow the oil and filter change intervals given in the maintenance schedule.

## Additives

Your Honda does not need any oil additives. Purchasing additives for the engine or transmission will not increase your car's performance or longevity. It only increases the cost of operating your car.

## Changing the Oil and Filter

Always change the oil and filter according to the time and distance (miles/kilometers) recommendations in the maintenance schedule. The oil and filter collect contaminants that can damage your engine if they are not removed regularly.

Changing the oil and filter requires special tools and access from underneath the car. The car should be raised on a service station-type hydraulic lift for this service. Unless you have the knowledge and proper equipment, you should have this maintenance done by a skilled mechanic.

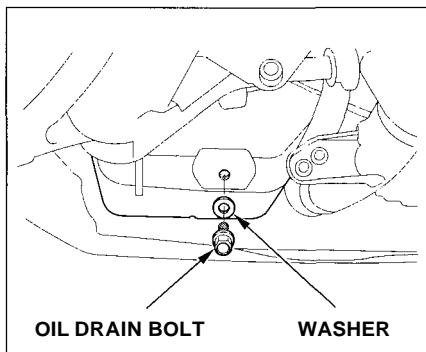

1. Run the engine until it reaches normal operating temperature, then shut it off.
2. Open the hood and remove the engine oil fill cap. Remove the oil drain bolt and washer from the bottom of the engine. Drain the oil into an appropriate container.

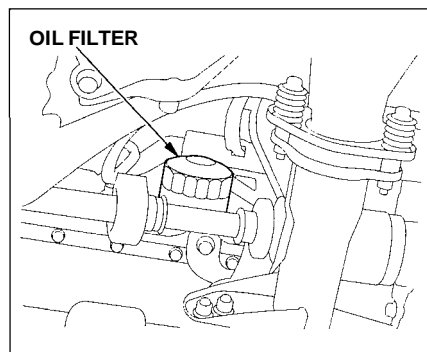

3. Remove the oil filter and let the remaining oil drain. A special wrench (available from your Honda dealer) is required to remove the filter.
4. Install a new oil filter according to instructions that come with it.

5. Put a new washer on the drain bolt, then reinstall the drain bolt.

Tighten it to:

(DX)

44 N.m (4.5 kgf.m , 33 lbf-ft)

(U.S.: HX, EX, Canada: Si)

39 N.m (4.0 kgf.m , 29 lbf-ft)

6. Refill the engine with the recommended oil.

Engine oil change capacity  
(including filter):

(DX)

3.3 ℓ (3.5US qt, 2.9Impqt)

(U.S.: HX, EX, Canada: Si)

3.6 ℓ (3.8 US qt ,3.2 Imp qt)

7. Replace the engine oil fill cap.

Start the engine. The oil pressure indicator light should go out within five seconds. If it does not, turn off the engine and reinspect your work.

8. Let the engine run for several minutes and check the drain bolt and oil filter for leaks.

9. Turn off the engine, let it sit for several minutes, then check the oil level. If necessary, add oil to bring the level to the upper mark on the dipstick.

## NOTICE

*Improper disposal of engine oil can be harmful to the environment. If you change your own oil, please dispose of the used oil properly. Put it in a sealed container and take it to a recycling center. Do not discard it in a trash bin or dump it on the ground.*

# Cooling System

## Adding Engine Coolant

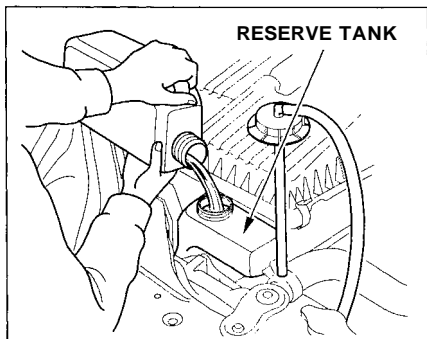

If the coolant level in the reserve tank is at or below the MIN line, add coolant to bring it up to the MAX line. Inspect the cooling system for leaks. This coolant should always be a mixture of 50 percent antifreeze and 50 percent water. Never add straight antifreeze or plain water.

Always use Genuine Honda antifreeze/coolant. If it is not available, you may use another major-brand non-silicate coolant as a temporary replacement. Make sure it is a high-quality coolant recommended for aluminum engines. However, continued use of any non-Honda coolant can result in corrosion, causing the cooling system to malfunction or fail. Have the cooling system flushed and refilled with Honda antifreeze/coolant as soon as possible.

Removing the radiator cap while the engine is hot can cause the coolant to spray out, seriously scalding you.

Always let the engine and radiator cool down before removing the radiator cap.

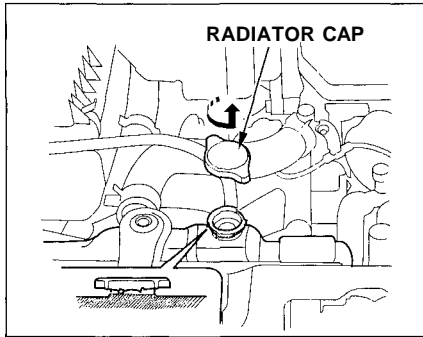

1. Make sure the engine and radiator are cool.
2. Turn the radiator cap counter-clockwise, without pressing down on it, until it stops. This relieves any pressure remaining in the cooling system.
3. Remove the radiator cap by pushing down and turning counterclockwise.

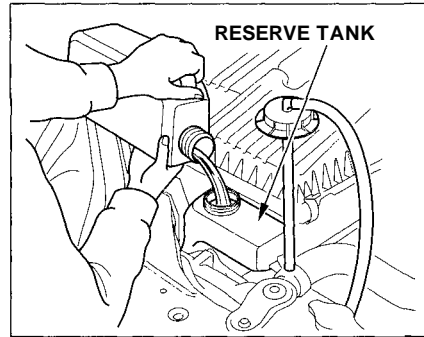

4. The coolant level should be up to the base of the filler neck. Add coolant if it is low.
5. Put the radiator cap back on. Tighten it fully.
6. Pour coolant into the reserve tank. Fill it to halfway between the MAX and MIN marks. Put the cap back on the reserve tank.

Do not add any rust inhibitors or other additives to your car's cooling system. They may not be compatible with the coolant or engine components.



# Cooling System

## Replacing Engine Coolant

The cooling system should be completely drained and refilled with new coolant according to the time and distance recommendations in the maintenance schedule. Only use Genuine Honda antifreeze/coolant.

Draining the coolant requires access to the underside of the car. Unless you have the tools and knowledge, you should have this maintenance done by a skilled mechanic.

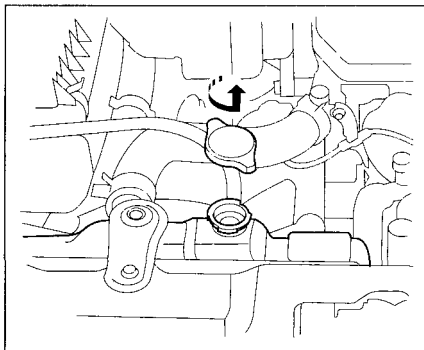

1. Slide the heater temperature control lever to maximum heat. Open the hood. Make sure the engine and radiator are cool to the touch.
2. Remove the radiator cap.

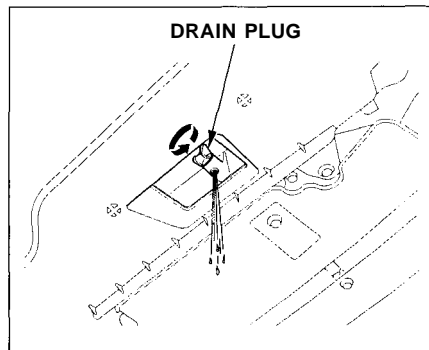

3. Loosen the drain plug on the bottom of the radiator. The coolant will come out through the hole in the splash cover.

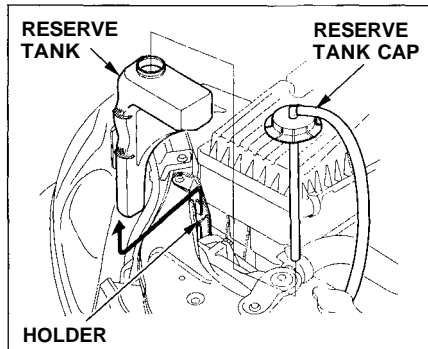

4. Remove the reserve tank from its holder by pulling it straight up. Drain the coolant, then put the tank back in its holder.

5. When the coolant stops draining, tighten the drain plug in the bottom of the radiator.
6. Mix the recommended antifreeze with an equal amount of purified or distilled water in a clean container. The cooling system capacity is:

*With 5-speed manual transmission:*

3.1 l (0.82 US gal, 0.68 Imp gal)

*With automatic transmission:*

(DX)

3.0 l (0.79 US gal, 0.66 Imp gal)

(U.S.: HX, EX, Canada: Si)

3.2 l (0.85 US gal, 0.70 Imp gal)

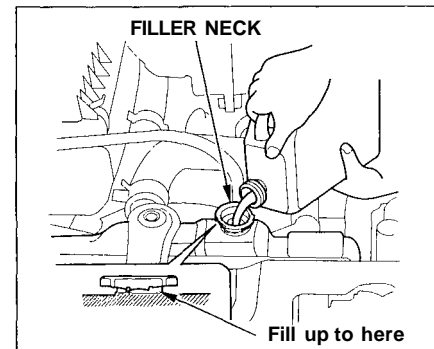

7. Pour coolant into the radiator up to the base of the filler neck.

CONTINUED

## Cooling System

---

- Put the cap on the radiator, and tighten it only to the first stop. Start the engine and let it run until it warms up (the radiator cooling fan comes on at least twice).
- Turn off the engine. Check the level in the radiator, add coolant if needed. Install the radiator cap, and tighten it fully.

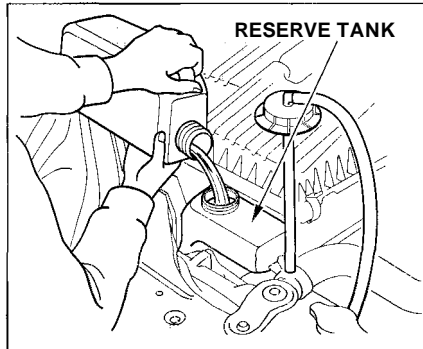

- Fill the reserve tank to the MAX mark. Install the reserve tank cap.

Check the level in the windshield washer reservoir at least monthly during normal usage. In bad weather, when you use the washers often, check the level every time you stop for fuel.

The windshield washer reservoir is located behind the driver's side headlight. Check the reservoir's fluid level by removing the cap and looking at the level gauge attached to the cap.

Fill the reservoir with a good-quality windshield washer fluid. This increases the cleaning capability and prevents freezing in cold weather.

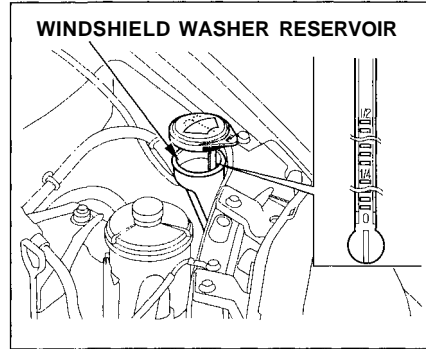

## NOTICE

*Do not use engine antifreeze or a vinegar/water solution in the windshield washer reservoir.*

*Antifreeze can damage your car's paint, while a vinegar/water solution can damage the windshield washer pump.*

*Use only commercially-available windshield washer fluid.*

## Automatic Transmission

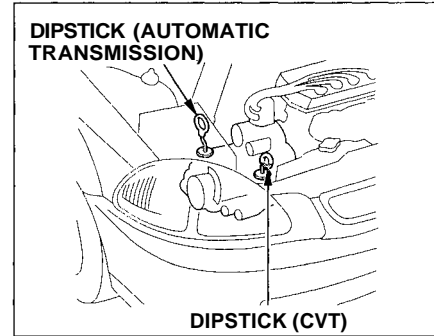

The engine and transmission must be at normal operating temperature before checking the fluid level. Drive the car at least 10 miles (16 kilometers) before checking.

1. Park the car on level ground. Shut off the engine. For accurate results, wait at least 60 seconds, and no more than 90 seconds, after shutting off the engine to check the fluid level.

CONTINUED

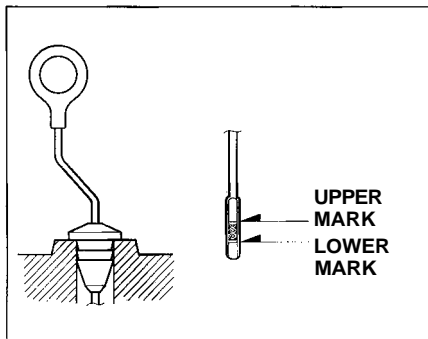

2. Remove the dipstick (yellow loop) from the transmission and wipe it with a clean cloth.
3. Insert the dipstick all the way into the transmission securely as shown in the illustration.
4. Remove the dipstick and check the fluid level. It should be between the upper and lower marks.

5. If the level is below the lower mark, add fluid into the filler hole to bring it to the upper mark. Always use Honda Premium Formula Automatic Transmission Fluid (ATF). If it is not available, you may use a DEXRON® III automatic transmission fluid as a temporary replacement. However, continued use can affect shift quality. Have the transmission drained and refilled with Honda ATF as soon as it is convenient,

*HX model (CVT) only:*

Use Genuine Honda CVT fluid only. Using other fluids can affect transmission operation and may reduce transmission life.

6. Insert the dipstick all the way back into the transmission securely as shown in the illustration.

The transmission should be drained and refilled with new fluid according to the time and distance recommendations in the maintenance schedule.

*HX model (CVT) only:*

If you drive at high speeds in high (90° F/32°C and above) temperatures, the transmission fluid should be changed every 15,000 miles (24,000 km).

## 5-speed Manual Transmission

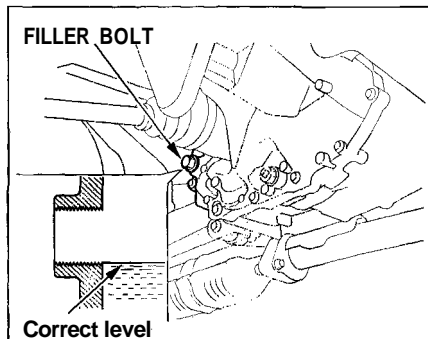

Check the fluid level with the transmission at normal operating temperature and the vehicle sitting on level ground. Remove the transmission filler bolt and carefully feel inside the bolt hole with your finger. The fluid level should be up to the edge of the bolt hole. If it is not, add Genuine Honda Manual Transmission Fluid (MTF) until it starts to run out of the hole. Reinstall the filler bolt and tighten it securely.

If Honda MTF is not available, you may use an API service SG or SH grade motor oil with a viscosity of SAE 10W-30 or 10W-40 as a temporary replacement. However, motor oil does not contain the proper additives and continued use can cause stiffer shifting. Replace as soon as convenient.

The transmission should be drained and refilled with new fluid according to the time and distance recommendations in the maintenance schedule.

## Brake and Clutch Fluid

Check the fluid level in the reservoirs monthly. There are one or two reservoirs, depending on model. They are:

- Brake fluid reservoir (all models)
- Clutch fluid reservoir (manual transmission only)

The brake fluid in the brake system should be replaced according to the time and distance recommendations in the maintenance schedule.

# Brake and Clutch Fluid

## Brake Fluid

Always use Genuine Honda DOT 3 brake fluid. If it is not available, you should use only DOT 3 or DOT 4 fluid, from a sealed container, as a temporary replacement. However, the use of any non-Honda brake fluid can cause corrosion and decrease the life of the system. Have the brake system flushed and refilled with Honda DOT 3 brake fluid as soon as possible.

Brake fluid marked DOT 5 is not compatible with your car's braking system and can cause extensive damage.

## Brake System

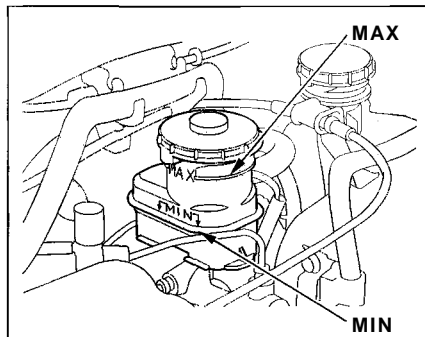

The fluid level should be between the MIN and MAX marks on the side of the reservoir. If the level is at or below the MIN mark, your brake system needs attention. Have the brake system inspected for leaks or worn brake pads.

## Clutch System

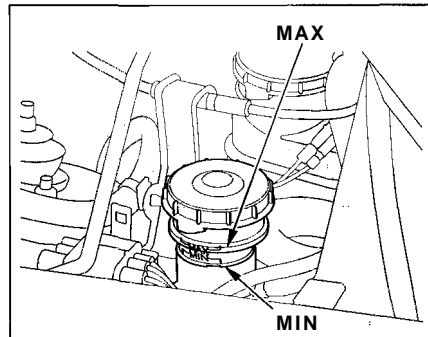

The fluid should be between the MIN and MAX marks on the side of the reservoir. If it is not, add brake fluid to bring it up to that level. Use the same fluid specified for the brake system.

Low fluid level can indicate a leak in the clutch system. Have this system inspected as soon as possible.

*On DX model with automatic transmission, HX and EX models in the U.S., and DX and Si models in Canada*  
Check the level when the engine is cold. Look at the side of the reservoir. The fluid should be between the UPPER LEVEL and LOWER LEVEL. If it is below the LOWER LEVEL, add power steering fluid to the UPPER LEVEL.

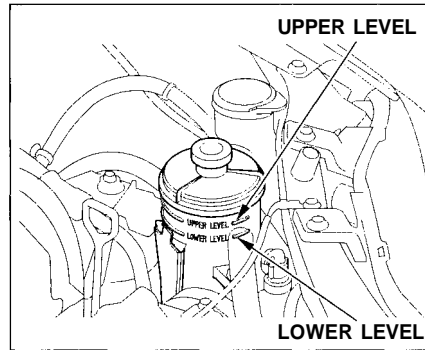

Always use Genuine Honda Power Steering Fluid. If it is not available, you may use another power steering fluid as an emergency replacement. However, continued use can cause increased wear and poor steering in cold weather. Have the power steering system flushed and refilled with Honda PSF as soon as possible.

A low power steering fluid level can indicate a leak in the system. Check the fluid level frequently and have the system inspected as soon as possible.

### NOTICE

*Turning the steering wheel to full left or right lock and holding it there can damage the power steering pump.*



# Air Cleaner Element

The air cleaner element should be replaced according to the time and distance recommendations in the maintenance schedule.

## Replacement

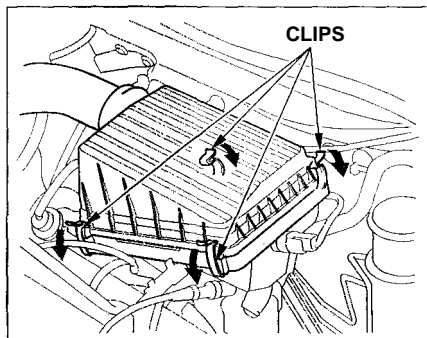

### *On DX model*

The air cleaner element is inside the air cleaner housing in the engine compartment.

To replace it:

1. Unsnap the four clips and remove the air cleaner housing cover.
2. Remove the old air cleaner element.

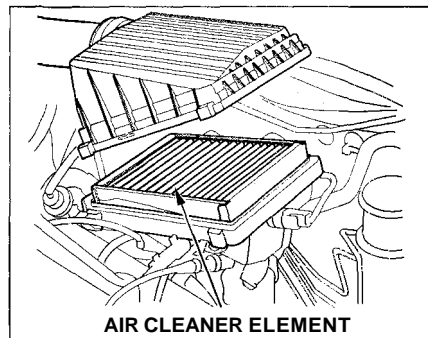

Clean the inside of the air cleaner housing with a damp rag.

3. Place the new air cleaner element in the air cleaner housing.
4. Reinstall the air cleaner housing cover, snap the four clips back into place.

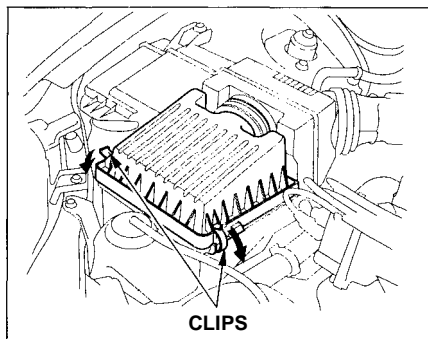

*On HX and EX models in the U.S., and Si model in Canada*

The air cleaner element is inside the air cleaner housing on the passenger's side of the engine compartment.

To replace it:

1. Unsnap the two clips and remove the air cleaner housing cover.

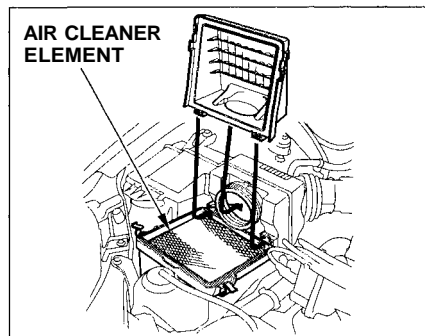

2. Remove the old air cleaner element.

Clean the inside of the air cleaner housing with a damp rag.

3. Place the new air cleaner element in the air cleaner housing.

4. Align the tabs and reinstall the air cleaner housing cover, snap the two clips back into place.

# Spark Plugs

The spark plugs in your car need to be replaced every 2 years or 30,000 miles (48,000 km), whichever comes first.

## Replacement

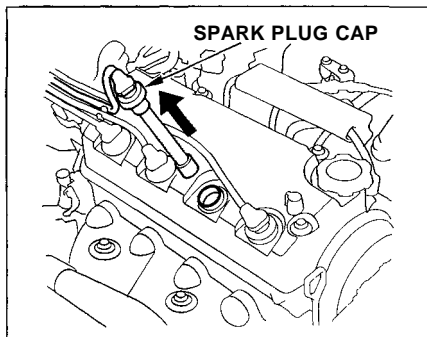

1. Clean up any dirt and oil around the spark plug caps.
2. Remove the spark plug cap by pulling it straight out.
3. Remove the spark plug with a five-eighths inch (16 mm) spark plug socket.

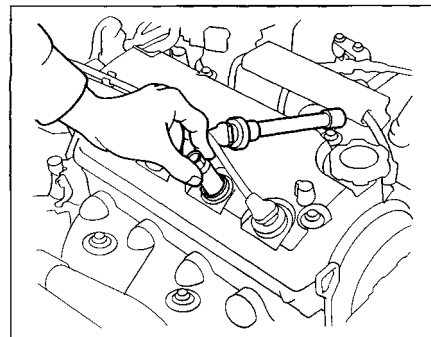

4. Put the new spark plug into the socket; then screw it into the hole. Screw it in by hand so you do not crossthead it.

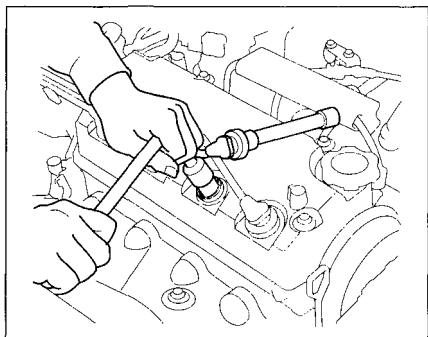

## NOTICE

*Tighten the spark plugs carefully. A spark plug that is too loose can overheat and damage the engine. Overtightening can cause damage to the threads in the cylinder head.*

6. Install the spark plug cap.
7. Repeat this procedure for the other three spark plugs.

5. Torque the spark plug. (If you do not have a torque wrench, tighten the spark plug two-thirds of a turn after it contacts the cylinder head.)  
Tightening torque:  
18 N.m (1.8 kgf.m, 13 lbf.ft)

## Specifications:

(U.S.: HX)

NGK: ZFR4F-11  
DENSO: KJ14CR-L11

(U.S.: DX, EX, Canada: DX, Si)

NGK: ZFR5F-11  
DENSO: KJ16CR-L11

Spark Plug Gap:

1.1 mm (0.04 in)  $\begin{matrix} +0 \\ 0.1\text{mm} \end{matrix}$

## Battery

Check the condition of your car's battery monthly. You should check the color of the test indicator window, and for corrosion on the terminals.

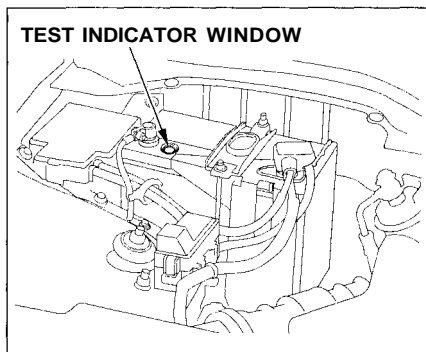

Check the battery condition by looking at the test indicator window on the battery. The label on the battery explains the test indicator's colors.

Check the battery terminals for corrosion (a white or yellowish powder). To remove it, cover the terminals with a solution of baking soda and water. It will bubble up and turn brown. When this stops, wash it off with plain water. Dry off the battery with a cloth or paper towel. Coat the terminals with grease to help prevent future corrosion.

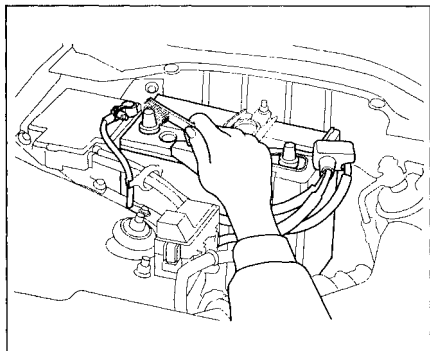

If the terminals are severely corroded, clean them with baking soda and water. Then use a wrench to loosen and remove the cables from the terminals. Always disconnect the negative ( — ) cable first and reconnect it last. Clean the battery terminals with a terminal cleaning tool or wire brush. Reconnect and tighten the cables, then coat the terminals with grease.

If you need to connect the battery to a charger, disconnect both cables to prevent damage to the car's electrical system.

The battery gives off explosive hydrogen gas during normal operation.

A spark or flame can cause the battery to explode with enough force to kill or seriously hurt you.

Wear protective clothing and a face shield, or have a skilled mechanic do the battery maintenance.

## NOTICE

*Charging the battery with the cables connected can seriously damage your car's electronic controls. Detach the battery cables before connecting the battery to a charger.*

## Windshield Wipers

Check the condition of the windshield wiper blades at least every six months. Look for signs of cracking in the rubber, or areas that are getting hard. Replace the blades if you find these signs, or they leave streaks and unwiped areas when used.

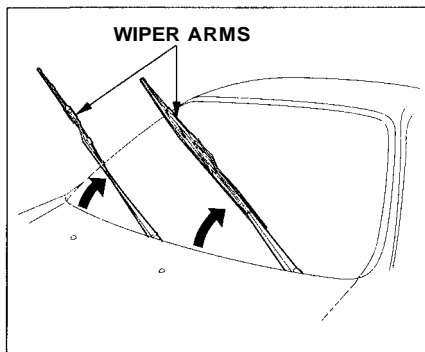

To replace the blade:

1. Raise the wiper arm off the windshield.

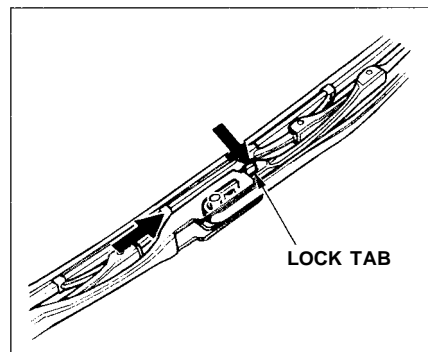

2. Disconnect the blade assembly from the wiper arm by pushing in the lock tab. Hold it in while you push the blade assembly toward the base of the arm.

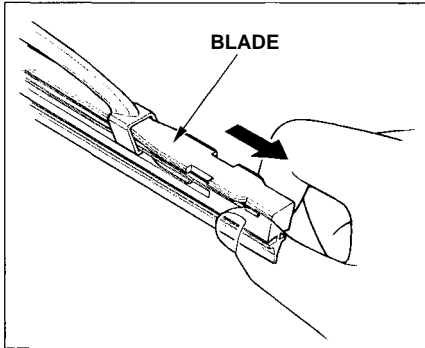

3. Remove the blade from its holder by grasping the tabbed end of the blade. Pull firmly until the tabs come out of the holder.

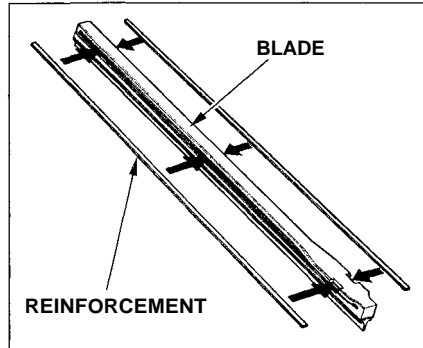

4. Examine the new wiper blades. If they have no plastic or metal reinforcement along the back edge, remove the metal reinforcement strips from the old wiper blade and install them in the slots along the edge of the new blade.

5. Slide the new wiper blade into the holder until the tabs lock.
6. Slide the wiper blade assembly onto the wiper arm. Make sure it locks in place.
7. Lower the wiper arm down against the windshield.



# Air Conditioning System

*Standard on U.S. EX model*

Your car's air conditioning is a sealed system. Any major maintenance, such as recharging, should be done by a qualified technician. You can do a couple of things to make sure the air conditioning works efficiently.

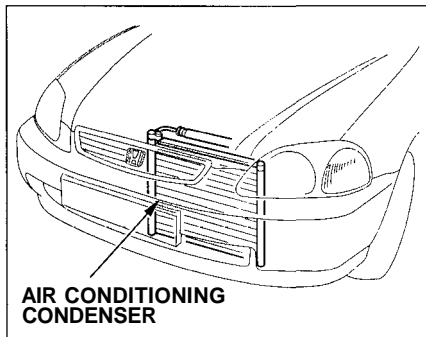

Periodically check the engine's radiator and air conditioning condenser for leaves, insects, and dirt stuck to the front surface. These block the air flow and reduce cooling efficiency. Use a light spray from a hose or a soft brush to remove them.

## NOTICE

*The condenser and radiator fins bend easily. Only use a low-pressure spray or soft-bristle brush to clean them.*

Run the air conditioning at least once a week during the cold weather months. Run it for at least ten minutes while you are driving at a steady speed with the engine at normal operating temperature. This circulates the lubricating oil contained in the refrigerant.

If the air conditioning does not get as cold as before, have your dealer check the system. Recharge the system with Refrigerant HFC-134a (R-134a). (See Specifications on page 205.)

## NOTICE

*Whenever you have the air conditioning system serviced, make sure the service facility uses a refrigerant recycling system. This systems captures the refrigerant for reuse. Releasing refrigerant into the atmosphere can damage the environment. .*

## Drive Belts

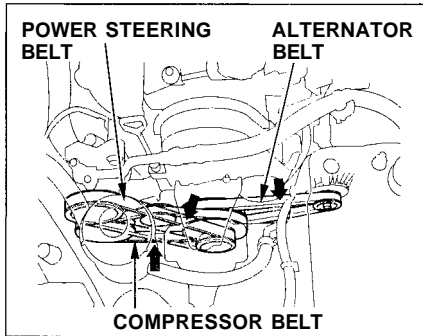

Check the condition of the two or three drive belts. Examine the edges of each belt for cracks or fraying. Check the tension of each belt by pushing on it with your thumb midway between the pulleys.

The belts should have the following "play" or deflection.

Alternator belt:

8.0 — 10.5 mm (0.31 — 0.41 in)

Power steering belt:

10.5 — 14.0 mm (0.41 — 0.55 in)

*On cars with Air Conditioning*

Compressor belt:

7.5 — 9.5 mm (0.30 — 0.37 in)

If you see signs of wear or looseness, have your dealer adjust or replace the belts.

## Timing Belt

The timing belt should normally be replaced at the intervals shown in the maintenance schedule.

Replace this belt at 60,000 miles (U.S.) or 100,000 km (Canada) if you regularly drive your car in one or more of these conditions:

- In very high temperatures (over 110°F, 43°C).
- In very low temperatures (under —20°F, —29°C).

To safely operate your car, your tires must be the proper type and size, in good condition with adequate tread, and correctly inflated. The following pages give more detailed information on how and when to check air pressure, how to inspect your tires for damage and wear, and what to do when your tires need to be replaced.

Using tires that are excessively worn or improperly inflated can cause a crash in which you can be seriously hurt or killed.

Follow all instructions in this owner's manual regarding tire inflation and maintenance.

## **Inflation**

Keeping the tires properly inflated provides the best combination of handling, tread life and riding comfort. Underinflated tires wear unevenly, adversely affect handling and fuel economy, and are more likely to fail from being overheated. Overinflated tires can make your car ride more harshly, are more prone to damage from road hazards, and wear unevenly.

We recommend that you visually check your tires every day. If you think a tire might be low, check it immediately with a tire gauge.

Use a gauge to measure the air pressure at least once a month. Even tires that are in good condition may lose one to two psi per month. Remember to check the spare tire at the same time you check all the other tires.

Check the pressure in the tires when they are cold. This means the car has been parked for at least three hours. If you have to drive the car before checking the tire pressure, the tires can still be considered "cold" if you drive less than 1 mile (1.6km).

If you check the pressure when the tires are hot (the car has been driven several miles), you will see readings 4 to 6 psi (0.3 to 0.4 kgf/cm<sup>2</sup>, 30 to 40 kPa) higher than the cold reading. This is normal. Do not let air out to match the specified cold pressure. The tire will be underinflated.

You should get your own tire pressure gauge and use it whenever you check your tire pressures. This will make it easier for you to tell if a pressure loss is due to a tire problem and not due to a variation between gauges.

### **Recommended Tire Pressures for Normal Driving**

The following chart shows the recommended cold tire pressures for most normal driving conditions and speeds. Tire pressures for high speed driving are shown on page 207.

Tire Size	Cold Tire Pressure for Normal Driving
P185/65R14 85S	Front: 210 kPa (2.1 kgf/cm <sup>2</sup> , 30 psi) Rear: 200 kPa (2.0 kgf/cm <sup>2</sup> , 29 psi)

The compact spare tire pressure is:  
420 kPa (4.2 kgf/cm<sup>2</sup>, 60 psi)

These pressures are also given on the tire information label on the driver's doorjamb.

Tubeless tires have some ability to self-seal if they are punctured. However, because leakage is often very slow, you should look closely for punctures if a tire starts losing pressure.

## Inspection

Every time you check inflation, you should also examine the tires for damage, foreign objects, and wear. You should look for:

- Bumps or bulges in the tread or side of the tire. Replace the tire if you find either of these conditions.
- Cuts, splits, or cracks in the side of the tire. Replace the tire if you can see fabric or cord.
- Excessive tread wear.

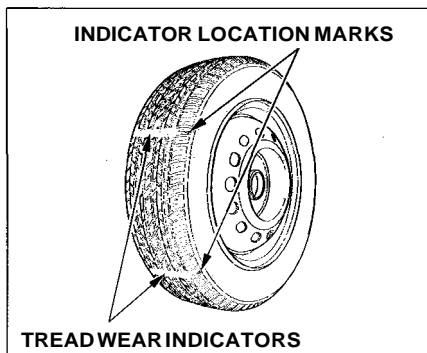

Your car's tires have wear indicators molded into the tread. When the tread wears down to that point, you will see a 1/2 inch (12.7 mm) wide band running across the tread. This shows there is less than 1/16 inch (1.6 mm) of tread left on the tire. A tire that is this worn gives very little traction on wet roads. You should replace the tire if you can see the tread wear indicator in three or more places around the tire.

## Maintenance

In addition to proper inflation, correct wheel alignment helps to decrease tire wear. If you find a tire is worn unevenly, have your dealer check the wheel alignment.

The tires were properly balanced by the factory. They may need to be rebalanced at some time before they are worn out. Have your dealer check the tires if you feel a consistent vibration while driving. A tire should always be rebalanced if it is removed from the wheel for repair.

Make sure the installer balances the wheels when you have new tires installed. This increases riding comfort and tire life. Your car's original tires were dynamic or "spin" balanced at the factory. For best results, have the installer perform a dynamic balance.

### NOTICE

(HX)

*Improper wheel weights can damage your car's aluminum wheels. Use only Genuine Honda wheel weights for balancing.*

### Tire Rotation

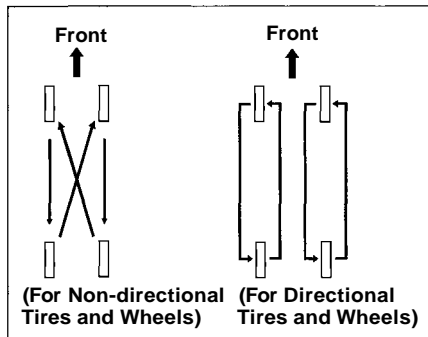

To help increase tire life and distribute wear more evenly, you should have the tires rotated every 7,500 miles (12,000 km). Move the tires to the positions shown in the chart each time they are rotated.

When shopping for replacement tires, you may find that some tires are "directional." This means they are designed to rotate only in one direction. If you use directional tires, they should be rotated only front-to-back.

### Replacing Tires and Wheels

The tires that came with your car were selected to match the performance capabilities of the car while providing the best combination of handling, ride comfort, and long life. You should replace them with radial tires of the same size, load range, speed rating, and maximum cold tire pressure rating (as shown on the tire's sidewall). Mixing radial and bias-ply tires on your car can reduce its braking ability, traction, and steering accuracy.

CONTINUED

Installing improper tires on your car can affect handling and stability. This can cause a crash in which you can be seriously hurt or killed.

Always use the size and type of tires recommended in this owner's manual.

It is best to replace all four tires at the same time. If that is not possible or necessary, then replace the two front tires or the two rear tires as a pair. Replacing just one tire can seriously affect your car's handling.

The ABS works by comparing the speed of the wheels. When replacing tires, use the same size originally supplied with the car. Tire size and construction can affect wheel speed and may cause the system to work inconsistently.

If you ever need to replace a wheel, make sure the wheel's specifications match those of the original wheel that came on your car. Replacement wheels are available at your Honda dealer.

## Wheels and Tires

Wheels:  
(U.S.: DX, EX, Canada: Si)  
14 x 5 J  
(U.S.: HX)  
14 x 5 1/2 JJ

Tires:  
P185/65R1485S

See *Tire Information* on page [206](#) for additional information about tire and wheel size designations. See page [207](#) for information about DOT Tire Quality Grading.

## Winter Driving

Tires that are marked "M+S" or "All Season" on the sidewall have an all-weather tread design. They should be suitable for most winter driving conditions. Tires without these markings are designed for optimum traction in dry conditions. They may not provide adequate performance in winter driving. For the best performance in snowy or icy conditions, you should install snow tires or tire chains. They may be required by local laws under certain conditions.

**Snow Tires**

If you mount snow tires on your Honda, make sure they are radial tires of the same size and load range as the original tires. Mount snow tires on all four wheels to balance your car's handling in all weather conditions. Keep in mind the traction provided by snow tires on dry roads may not be as high as your car's original equipment tires. You should drive cautiously even when the roads are clear. Check with the tire dealer for maximum speed recommendations.

**Tire Chains**

Mount snow chains on your car when warranted by driving conditions or required by local laws. Make sure the chains are the correct size for your tires. Install them only on the front tires. If metal chains are used, they must be SAE class "S". Cable type traction devices can also be used.

When installing chains, follow the manufacturer's instructions and mount them as tightly as you can. Drive slowly with chains installed. If you hear the chains contacting the body or chassis, stop and tighten them. If they still make contact, slow down until it stops. Remove the chains as soon as you begin driving on cleared roads.

**NOTICE**

*Chains of the wrong size or that are improperly installed can damage your car's brake lines, suspension, body, and wheels. Stop driving if you hear the chains hitting any part of the car.*



Check the operation of your car's exterior lights at least once a month. A burned out bulb can create an unsafe condition by reducing your car's visibility and the ability to signal your intentions to other drivers.

Check the following:

- Headlights (low and high beam)
- Parking lights
- Taillights
- Brake lights
- High-mount brake light
- Turn signals
- Back-up lights
- Hazard light function
- License plate light
- Side marker lights
- Daytime running lights (Canadian cars)

If you find any bulbs are burned out, replace them as soon as possible. Refer to the chart on page [205](#) to determine what type of replacement bulb is needed.

## Headlight Aiming

The headlights were properly aimed when your car was new. You should check their aim if you regularly carry heavy items in the trunk. Each headlight assembly has horizontal and vertical adjustment indicators. These are set to their "0" positions after the headlights are aimed at the factory.

To check these settings:

1. Make sure the fuel tank is full. Park the car on level ground.
2. The driver or someone who weighs the same should be sitting in the driver's seat for all checks and adjustments. Load the trunk with the items you normally carry.

## HORIZONTAL ANGLE GAUGE

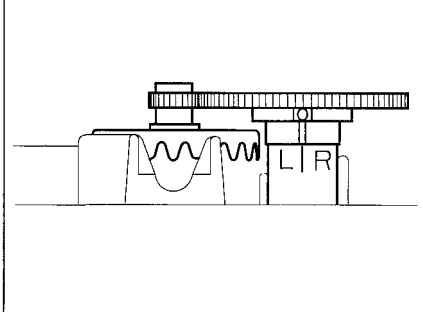

3. Open the hood.
4. Check the horizontal angle gauge. The line on the adjustment screw indicator should line up with the "0" mark on the gauge.

## VERTICAL ANGLE GAUGE

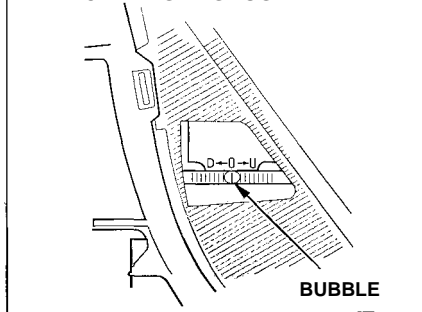

5. Check the vertical angle gauge. The bubble should be centered underneath the longest scribe mark on the gauge.

## HORIZONTAL ADJUSTMENT

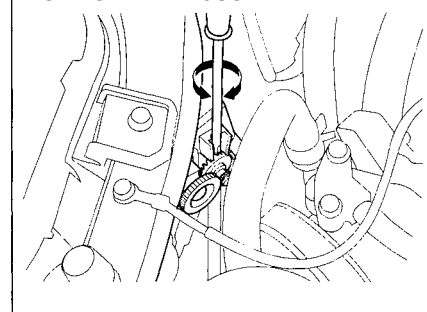

6. If either indicator is not aligned with its "0" mark as described, an adjustment can be made using a Phillips-head screwdriver to realign it with the "0" mark. Please refer to the illustrations.

CONTINUED

## VERTICAL ADJUSTMENT

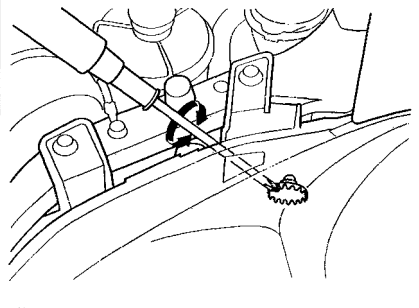

7. If you cannot get an indicator to align, have your Honda dealer inspect the car for body damage or suspension problems.

## Replacing a Headlight Bulb

Your car has halogen headlight bulbs, one on each side. When replacing a bulb, handle it by its steel base and protect the glass from contact with your skin or hard objects. If you touch the glass, clean it with denatured alcohol and a clean cloth.

### NOTICE

*Halogen headlight bulbs get very hot when lit. Oil, perspiration, or a scratch on the glass can cause the bulb to overheat and shatter.*

## HOLDER

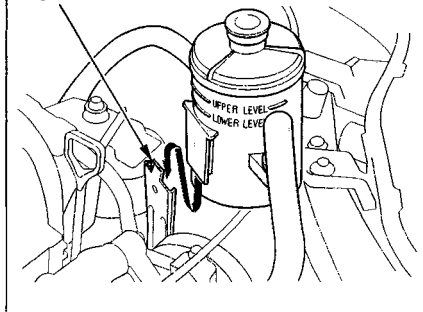

1. Open the hood.  
If you need to change the headlight bulb on the driver's side, remove the power steering reservoir tank by pulling it out of its holder.

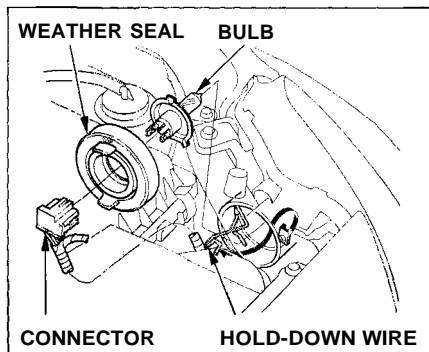

2. Remove the electrical connector from the bulb by squeezing the connector on both sides to unlock the tab. Pull the connector straight off.

3. Remove the rubber weather seal by pulling on the tab.

4. Unclip the end of the hold-down wire from its slot. Pivot it out of the way and remove the bulb.

5. Insert the new bulb into the hole, making sure the tabs are in their slots. Pivot the hold-down wire back in place and clip the end into the slot.

6. Install the rubber seal over the back of the headlight assembly. Make sure it is right side up; it is marked "TOP".

7. Push the electrical connector onto the tabs of the new bulb. Make sure it locks in place. Turn on the headlights to test the new bulb.

8. (Driver's side)  
Reinstall the power steering reservoir.

## Replacing the Front Side Marker/ Turn Signal and Parking Light Bulb

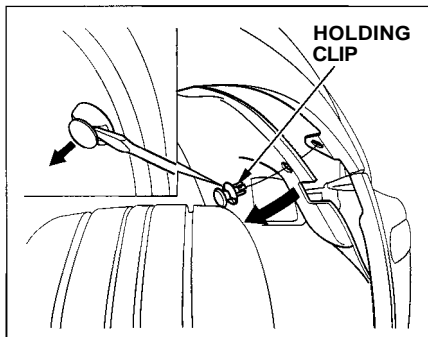

1. If you are changing the bulb on the driver's side, start the engine, turn the steering wheel all the way to the right, and turn off the engine. If you are changing the bulb on the passenger's side, turn the steering wheel to the left.

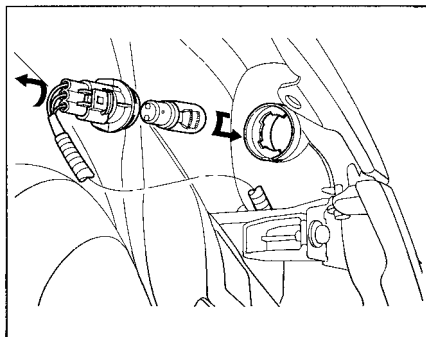

2. Use a flat-tipped screwdriver to remove the holding clip from the inner fender.
3. Pull the inner fender cover off.
4. Remove the socket from the headlight assembly by turning it one-quarter turn counterclockwise.

5. Remove the burned out bulb from the socket by pushing it in and turning counterclockwise until it unlocks.
6. Install the new bulb in the socket. Turn it clockwise to lock it in place.
7. Insert the socket back into the headlight assembly. Turn it clockwise to lock it in place.
8. Test the lights to make sure the new bulb is working.
9. Put the inner fender cover in place. Install the holding clip and tighten it securely.

## Replacing Rear Bulbs (in Fenders)

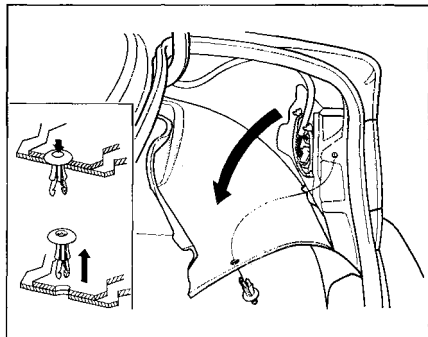

1. Open the trunk.

Undo the fastener on the side of the trunk lining by pushing on the center of the fastener's head until it pops in. Pull the lining back.

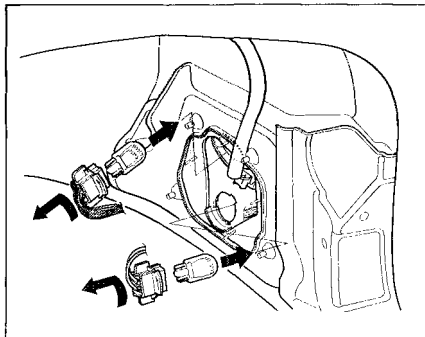

2. Determine which of the two bulbs is burned out: stop/taillight/side marker light or turn signal.
3. Remove the socket by turning it one-quarter turn counterclockwise.

4. Pull the bulb straight out of its socket. Push the new bulb straight into the socket until it bottoms.
5. Reinstall the socket into the light assembly by turning it clockwise until it locks.
6. Test the lights to make sure the new bulb is working.
7. Reinstall the trunk lining.

*CONTINUED*

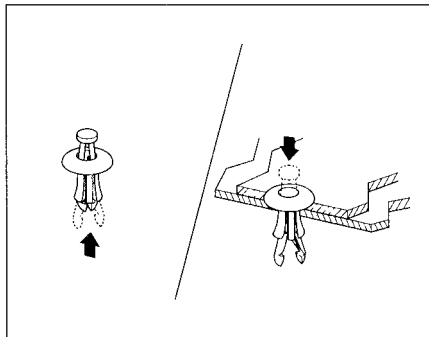

8. Reset the fastener by pushing on the pointed end until it pops back almost flush with the fingers on the housing.
9. Put the fastener in the hole of the side of the trunk lining and push on the center until it locks (the center is flush with the head).

## Replacing Rear Bulbs (in Trunk Lid)

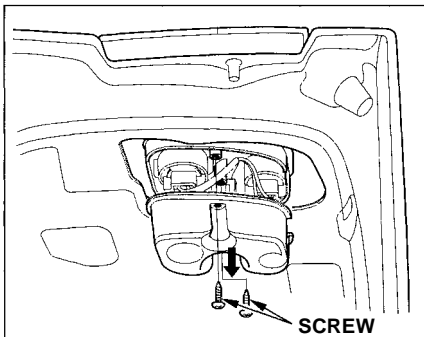

1. Open the trunk.
2. Use a Phillips-head screwdriver to remove the two screws from the bulb holder. Remove the holder from the taillight assembly.

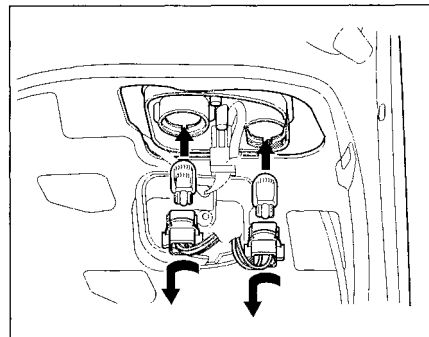

3. Determine which of the two bulbs is burned out: stop/taillight/side marker or back-up light.
4. Remove the socket by turning it one-quarter turn counterclockwise.

5. Pull the bulb straight out of its socket.  
Push the new bulb straight into the socket until it bottoms.
6. Insert the socket back into the light assembly. Turn it clockwise to lock it in place.
7. Test the lights to make sure the new bulb is working.
8. Reinstall the bulb holder assembly. Install the screw and tighten it securely.

## Replacing a High-mount Brake Light Bulb

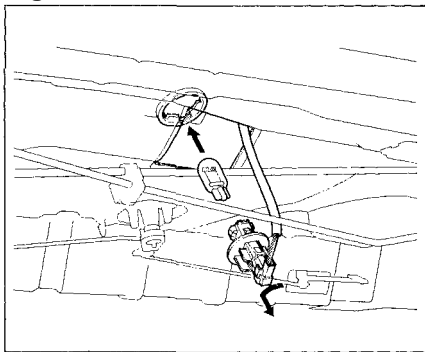

1. Open the trunk and remove the socket from the light assembly by turning it one-quarter turn counter-clockwise.
2. Pull the bulb straight out of its socket.  
Push the new bulb straight into the socket until it bottoms.

3. Reinstall the socket. Turn it clockwise until it locks. Make sure the new bulb is working.



## Replacing a Rear License Bulb

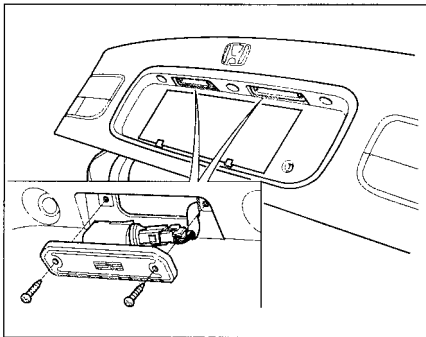

1. Remove the two screws and remove the license light assembly.
2. Remove the socket from the light assembly by turning it one-quarter turn counterclockwise.
3. Pull the bulb straight out of its socket. Push the new bulb in until it bottoms in the socket.

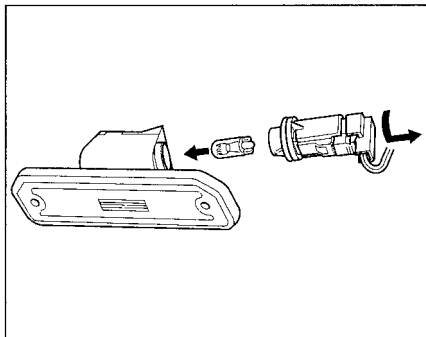

4. Turn on the parking lights and check that the new bulb is working.
5. Reinstall the socket. Turn it clockwise until it locks.
6. Put the license light assembly in place. Reinstall the two screws and tighten them securely.

## Replacing an Interior Light Bulb (U.S.: EX, Canada: Si)

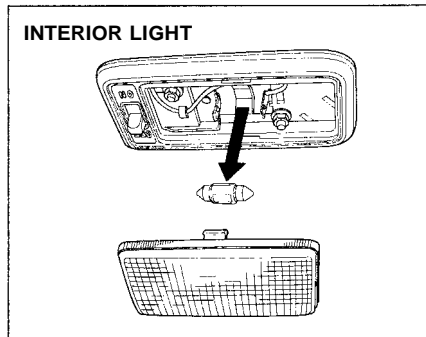

1. Remove the lens by carefully prying on the edge of the lens in the middle with a fingernail file or a small flat-tip screwdriver. Do not pry on the edge of the housing around the lens.

(U.S.: DX, HX, Canada: DX)

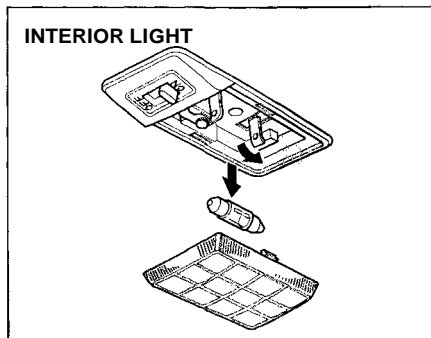

2. Remove the bulb by pulling it straight out of its metal tabs.
3. Push the new bulb into the metal tabs. Snap the lens back in place.

## Replacing the Trunk Light Bulb

*The trunk light is available on HX and EX models in the U.S., and Si model in Canada*

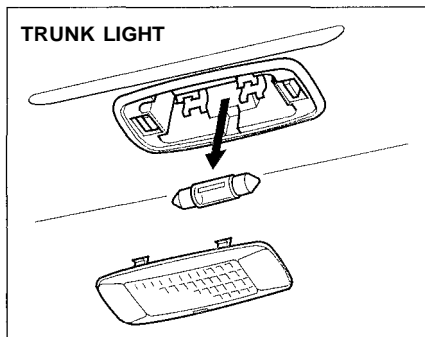

1. Remove the lens by carefully prying on the edge of the lens in the middle with a fingernail file or a small flat-tip screwdriver. Do not pry on the edge of the housing around the lens.

2. Remove the bulb by pulling it straight out of its metal tabs.
3. Push the new bulb into the metal tabs. Snap the lens back in place.

## Storing Your Car

---

If you need to park your car for an extended period (more than one month), there are several things you should do to prepare it for storage. Proper preparation helps prevent deterioration and makes it easier to get your car back on the road. If possible, store your car indoors.

- Fill the fuel tank.
- Change the engine oil and filter (see page 134).
- Wash and dry the exterior completely.
- Clean the interior. Make sure the carpeting, floor mats, etc. are completely dry.
- Leave the parking brake off. Put the transmission in Reverse (5-speed manual) or Park (automatic).

- Block the rear wheels.
- If the car is to be stored for a longer period, it should be supported on jackstands so the tires are off the ground.
- Leave one window open slightly (if the car is being stored indoors).
- Disconnect the battery.
- Support the front wiper blade arms with a folded towel or rag so they do not touch the windshield.
- To minimize sticking, apply a silicone spray lubricant to all door and trunk seals. Also, apply a car body wax to the painted surfaces that mate with the door and trunk seals.

- Cover the car with a "breathable" car cover, one made from a porous material such as cotton. Nonporous materials, such as plastic sheeting, trap moisture, which can damage the paint.
- If possible, run the engine for a while periodically (preferably once a month).

If you store your car for 12 months or longer, have your Honda dealer perform the inspections called for in the 24 months/30,000 miles (48,000 km) maintenance schedule (Normal Conditions) as soon as you take it out of storage (see page 126). The replacements called for in the maintenance schedule are not needed unless the car has actually reached that time or mileage.

Regular cleaning and polishing of your Honda helps to keep it "new" looking. This section gives you hints on how to clean your car and preserve its appearance: the paint, brightwork, wheels and interior. Also included are several things you can do to help prevent corrosion.

Exterior Care.....	174
Washing.....	174
Waxing.....	174
Aluminum Wheels.....	175
Paint Touch-up.....	175
Interior Care.....	176
Carpeting.....	176
Fabric.....	176
Vinyl.....	176
Seat Belts.....	176
Windows.....	177
Air Fresheners.....	177
Corrosion Protection.....	177
Body Repairs.....	178

### Washing

Frequent washing helps preserve your car's beauty. Dirt and grit can scratch the paint, while tree sap and bird droppings can permanently ruin the finish.

Wash your car in a shady area, not in direct sunlight. If the car is parked in the sun, move it into the shade and let the exterior cool down before you start.

Only use the solvents and cleaners recommended in this Owner's Manual.

#### NOTICE

*Chemical solvents and strong cleaners can damage the paint, metal, and plastic on your car.*

- Rinse the car thoroughly with cool water to remove loose dirt.

- Fill a bucket with cool water. Mix in a mild detergent, such as dishwashing liquid or a product made especially for car washing.
- Wash the car, using the water and detergent solution and a soft-bristle brush, sponge, or soft cloth. Start at the top and work your way down. Rinse frequently.
- Check the body for road tar, tree sap, etc. Remove these stains with tar remover or turpentine. Rinse it off immediately so it does not harm the finish. Remember to re-wax these areas, even if the rest of the car does not need waxing.
- When you have washed and rinsed the whole exterior, dry it with a chamois or soft towel. Letting it air-dry will cause dulling and water spots.

As you dry the car, inspect it for chips and scratches that could allow corrosion to start. Repair them with touch-up paint (see page 175).

### Waxing

Always wash and dry the whole car before waxing it. You should wax your car, including the metal trim, whenever water sits on the surface in large patches. It should form into beads or droplets after waxing.

You should use a quality liquid or paste wax. Apply it according to the instructions on the container. In general, there are two types of products:

**Waxes** — A wax coats the finish and protects it from damage by exposure to sunlight, air pollution, etc. You should use a wax on your Honda when it is new.

**Polishes** — Polishes and cleaner/waxes can restore the shine to paint that has oxidized and lost some of its shine. They normally contain mild abrasives and solvents that remove the top layer of the finish. You should use a polish on your Honda if the finish does not have its original shine after using a wax.

Cleaning tar, insects, etc. with removers also takes off the wax. Remember to re-wax those areas, even if the rest of the car does not need waxing.

### **Aluminum Wheels**

*On some models*

Clean your Honda's aluminum alloy wheels as you do the rest of the exterior. Wash them with the same solution, and rinse them thoroughly.

The wheels have a protective clear-coat that keeps the aluminum from corroding and tarnishing. Using harsh chemicals, including some commercial wheel cleaners, or stiff brushes can damage this clear-coat. Only use a mild detergent and soft brush or sponge to clean the wheels.

### **Paint Touch-up**

Your dealer has touch-up paint to match your car's color. The color code is printed on a sticker on the driver's doorjamb. Take this code to your dealer so you are sure to get the correct color.

Inspect your car frequently for chips or scratches in the paint. Repair them right away to prevent corrosion of the metal underneath. Use the touch-up paint only on small chips and scratches. More extensive paint damage should be repaired by a professional.

### Carpeting

Vacuum the carpeting frequently to remove dirt. Ground-in dirt will make the carpet wear out faster.

Periodically shampoo the carpet to keep it looking new. Use one of the foam-type carpet cleaners on the market. Follow the instructions that come with the cleaner, applying it with a sponge or soft brush. Keep the carpeting as dry as possible by not adding water to the foam.

### Fabric

Vacuum dirt and dust out of the material frequently. For general cleaning, use a solution of mild soap and lukewarm water, letting it air dry. To clean off stubborn spots, use a commercially-available fabric cleaner. Test it on a hidden area of the fabric first, to make sure it does not bleach or stain the fabric. Follow the instructions that come with the cleaner.

### Vinyl

Remove dirt and dust with a vacuum cleaner. Wipe the vinyl with a soft cloth dampened in a solution of mild soap and water. Use the same solution with a soft-bristle brush on more difficult spots. You can also use commercially-available spray or foam-type vinyl cleaners.

### Seat Belts

If your seat belts get dirty, you can use a soft brush with a mixture of mild soap and warm water to clean them. Do not use bleach, dye, or cleaning solvents. They can weaken the belt material. Let the belts air-dry before you use the car.

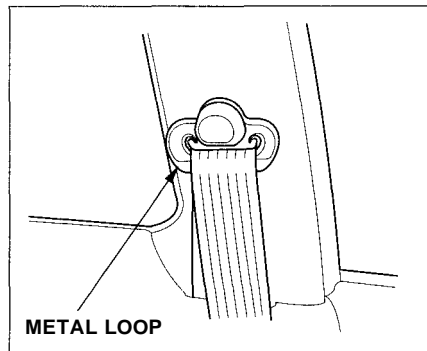

Dirt build-up in the metal loops of the seat belt anchors can cause the belts to retract slowly. Wipe the insides of the loops with a clean cloth dampened in mild soap and warm water or isopropyl alcohol.

## Windows

Clean the windows, inside and out, with a commercially-available glass cleaner. You can also use a mixture of one part white vinegar to ten parts water. This will remove the haze that builds up on the inside of the windows. Use a soft cloth or paper towels to clean all glass and clear plastic surfaces.

### NOTICE

*The rear window defogger wires are bonded to the inside of the glass. Wiping vigorously up-and-down can dislodge and break the defogger wires. When deeming the rear window, use gentle pressure and wipe side-to-side.*

## Air Fresheners

If you want to use an air freshener/deodorizer in the interior of your car, it is best to use a solid type. Some liquid air fresheners contain chemicals that may cause parts of the interior trim and fabric to crack or discolor.

If you use a liquid air freshener, make sure you fasten it securely so it does not spill as you drive.

## Corrosion Protection

Two factors normally contribute to causing corrosion in your car:

1. Moisture trapped in body cavities. Dirt and road salt that collects in hollows on the underside of the car stays damp, promoting corrosion in that area.
2. Removal of paint and protective coatings from the exterior and underside of the car.

Many corrosion-preventive measures are built into your Honda. You can help keep your car from corroding by performing some simple periodic maintenance:

- Repair chips and scratches in the paint as soon as you discover them.

CONTINUED



- Inspect and clean out the drain holes in the bottom of the doors and body.
- Check the floor coverings for dampness. Carpeting and floor mats may remain damp for a long time, especially in winter. This dampness can eventually cause the floor panels to corrode.
- Use a high-pressure spray to clean the underside of your car. This is especially important in areas that use road salt in winter. It is also a good idea in humid climates and areas subject to salt air. Cars equipped with ABS have a sensor and wiring at each wheel. Be careful not to damage them.
- Have the corrosion-preventive coatings on the underside of your car inspected and repaired periodically.

### **Body Repairs**

Body repairs can affect your car's resistance to corrosion. If your car needs repairs after a collision, pay close attention to the parts used in the repair and the quality of the work.

Make sure the repair facility uses Genuine Honda replacement body parts. Some companies make sheet metal pieces that seem to duplicate the original Honda body parts, but are actually inferior in fit, finish, and corrosion resistance. Once installed, they do not give the same high-quality appearance.

When reporting your collision to the insurance company, tell them you want Genuine Honda parts used in the repair. Although most insurers recognize the quality of original parts, some may try to specify that the repairs be done with other available parts. You should investigate this before any repairs are begun.

Take your car to your authorized Honda dealer for inspection after the repairs are completed. He can make sure that quality materials were used, and that corrosion-preventive coatings were applied to all repaired and replaced parts.

This section covers the more-common problems that motorists experience with their cars. It gives you information about how to safely evaluate the problem and what to do to correct it. If the problem has stranded you on the side of the road, you may be able to get going again. If not, you will also find instructions on getting your car towed.

Compact Spare Tire.....	180
Changing a Flat Tire.....	181
If Your Engine Won't Start.....	186
Nothing Happens or the Starter Motor Operates Very Slowly.....	186
The Starter Operates Normally.....	187
Jump Starting.....	187
If Your Engine Overheats.....	189
Low Oil Pressure Indicator.....	191
Charging System Indicator.....	192
Malfunction Indicator Lamp .....	193
Closing the Moonroof.....	194
Fuses.....	195
Checking and Replacing.....	196
Towing.....	200

## Compact Spare Tire

Your car has a compact spare tire that takes up less space. Use this spare tire as a temporary replacement only. Get your regular tire repaired or replaced and put back on your car as soon as you can.

Check the inflation pressure of the compact spare tire every time you check the other tires. It should be inflated to:  
420 kPa (4.2 kgf/cm<sup>2</sup> , 60 psi)

Follow these precautions whenever you are using the compact spare tire:

- Do not exceed 50 mph (80 km/h) under any circumstances.
- This tire gives a harsher ride and less traction on some road surfaces than the regular tire. Use greater caution while driving on this tire.
- Do not mount snow chains on the compact spare.
- The wheel of the compact spare tire is designed especially to fit your car. Do not use your spare tire on another car unless it is the same make and model.

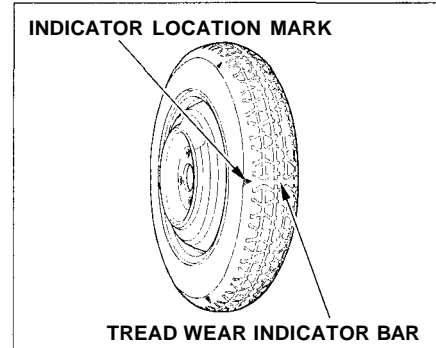

The compact spare tire has a shorter tread life than a regular tire. Replace it when you can see the tread wear indicator bars. The replacement should be the same size and design tire, mounted on the same wheel. The compact spare tire is not designed to be mounted on a regular wheel, and the compact wheel is not designed for mounting a regular tire.

If you have a flat tire while driving, stop in a safe place to change it. Stopping in traffic or on the shoulder of a busy road is dangerous. Drive slowly along the shoulder until you get to an exit or an area to stop that is far away from the traffic lanes.

The car can easily roll off the jack, seriously injuring anyone underneath.

Follow the directions for changing a tire exactly, and never get under the car when it is supported only by the jack.

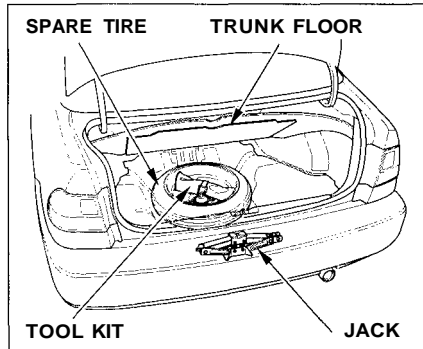

1. Park the car on firm, level ground away from traffic. Turn on the hazard warning lights and turn the ignition to LOCK (0).
2. Put the transmission in Park (automatic) or Reverse (manual). Set the parking brake. Have all of the passengers get out of the car while you change the tire.

3. Open the trunk. Raise the trunk floor by lifting up on the back edge.
4. Take the tool kit out of the trunk.
5. Unscrew the wing bolt and take the spare tire out of the trunk.

*CONTINUED*

## Changing a Flat Tire

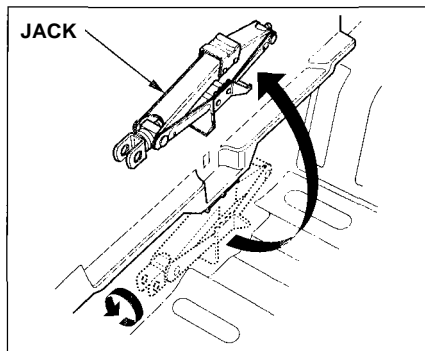

6. Turn the jack's end bracket counterclockwise to loosen it, then remove the jack.

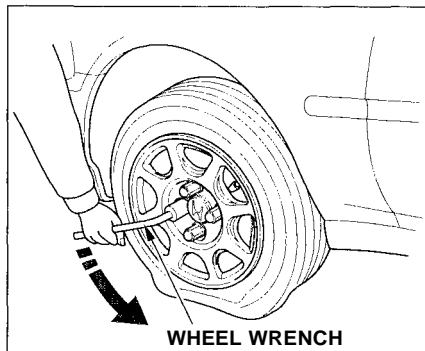

7. Loosen the four wheel nuts 1/2 turn with the wheel wrench.

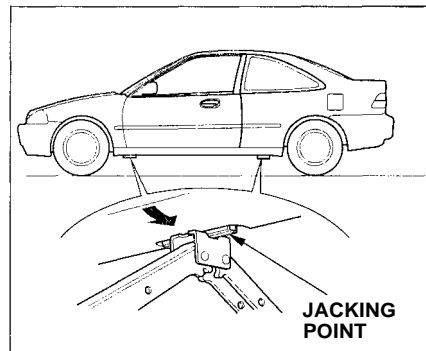

8. Locate the jacking point nearest the tire you need to change. It is pointed to by an arrow molded into the underside of the body. Place the jack under the jacking point. Turn the end bracket clockwise until the top of the jack contacts the jacking point. Make sure the jacking point tab is resting in the jack notch.

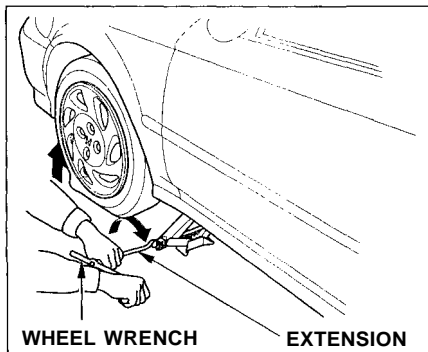

9. Use the extension and wheel wrench as shown to raise the car until the flat tire is off the ground.
10. Remove the wheel nuts and flat tire. Temporarily place the flat tire on the ground with the outside surface of the wheel facing up. You could scratch the wheel if you put it face down.

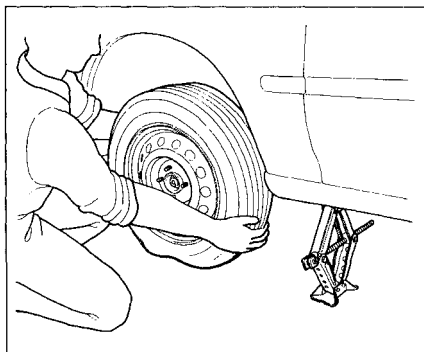

- On DX and EX models in the U.S., and DX and Si in Canada*
- Do not attempt to forcibly pry the wheel cover off with a screwdriver or other tool. The wheel cover cannot be removed without first removing the wheel nuts.

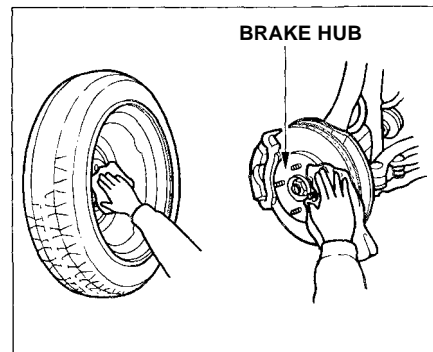

11. Before mounting the spare tire, wipe any dirt off the mounting surface of the wheel and hub with a clean cloth.

CONTINUED

## Changing a Flat Tire

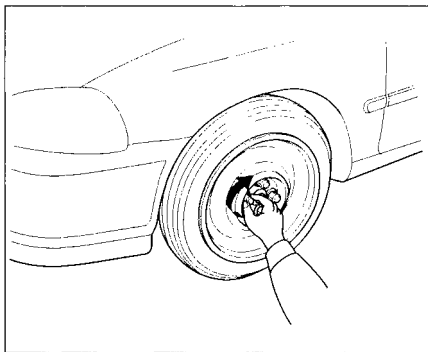

12. Put on the spare tire. Put the wheel nuts back on finger-tight, then tighten them in a crisscross pattern with the wheel wrench until the wheel is firmly against the hub. Do not try to tighten them fully.

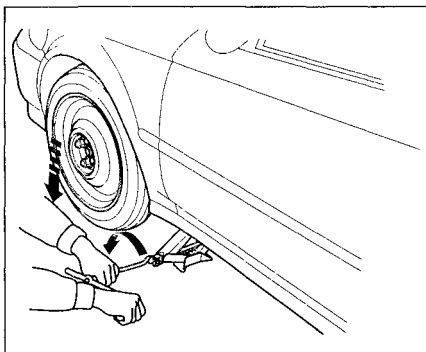

13. Lower the car to the ground and remove the jack.

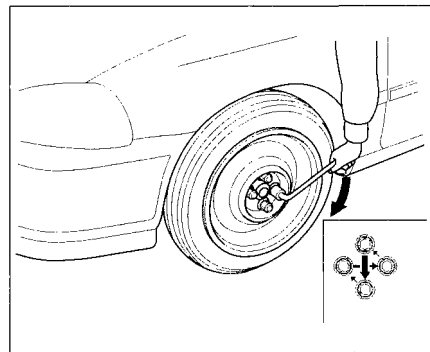

14. Tighten the wheel nuts securely in the same crisscross pattern. Have the wheel nut torque checked at the nearest automotive service facility.

Tighten the wheel nuts to:  
108 N.m (11 kgf.m , 80 lbf.ft)

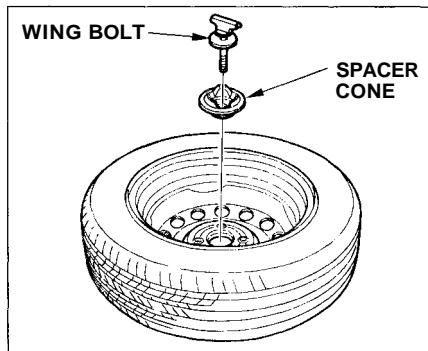

15. Remove the wheel cover or center cap.  
Place the flat tire face down in the trunk well.
16. Remove the spacer cone from the wing bolt, turn it over, and put it back on the bolt.
17. Secure the flat tire by screwing the wing bolt back into its hole.

18. Store the jack in the trunk with the end bracket on the left side. Turn the jack's end bracket to lock it in place. Store the tool kit.

Loose items can fly around the interior in a crash and could seriously injure the occupants.

Store the wheel, jack and tools securely before driving.

19. Store the wheel cover or center cap in the trunk. Make sure it does not get scratched or damaged.
20. Lower the trunk floor, then close the trunk lid.



Diagnosing why your engine won't start falls into two areas, depending on what you hear when you turn the key to START (III):

- You hear nothing, or almost nothing. The engine's starter motor does not operate at all, or operates very slowly.
- You can hear the starter motor operating normally, or the starter motor sounds like it is spinning faster than normal, but the engine does not start up and run.

### **Nothing Happens or the Starter Motor Operates Very Slowly**

When you turn the ignition switch to START (III), you do not hear the normal noise of the engine trying to start. You may hear a clicking sound or series of clicks, or nothing at all. Check these things:

- Check the transmission interlock. If you have a manual transmission, the clutch pedal must be pushed all the way to the floor or the starter will not operate. With an automatic transmission, it must be in Park or Neutral.
- Turn the ignition switch to ON (II). Turn on the headlights and check their brightness. If the headlights are very dim or don't light at all, the battery is discharged. See **Jump Starting** on page [187](#).

- Turn the ignition switch to START (III). If the headlights do not dim, check the condition of the fuses. If the fuses are OK, there is probably something wrong with the electrical circuit for the ignition switch or starter motor. You will need a qualified technician to determine the problem. (See **Towing** on page [200](#).)

If the headlights dim noticeably or go out when you try to start the engine, either the battery is discharged or the connections are corroded. Check the condition of the battery and terminal connections (see page [150](#)). You can then try jump starting the car from a booster battery (see page [187](#)).

## The Starter Operates Normally

In this case, the starter motor's speed sounds normal, or even faster than normal, when you turn the ignition switch to START (III), but the engine does not run.

- Are you using the proper starting procedure? Refer to **Starting the Engine** on page 101.
- Do you have fuel? Turn the ignition switch to ON (II) for a minute and watch (he fuel gauge. The low fuel level warning light may not be working, so you were not reminded to fill the tank.
- There may be an electrical problem, such as no power to the fuel pump. Check all the fuses (see page 195).

If you find nothing wrong, you will need a qualified technician to find the problem. See **Towing** on page 200.

## Jump Starting

If your car's battery has run down, you may be able to start the engine by using a booster battery. Although this seems like a simple procedure, you should take several precautions.

A battery can explode if you do not follow the correct procedure, seriously injuring anyone nearby.

Keep all sparks, open flames, and smoking materials away from the battery.

You cannot start a Honda with an automatic transmission by pushing or pulling it.

To jump start your car, follow these directions closely:

1. Open the hood and check the physical condition of the battery (see page 150). In very cold weather, check the condition of the electrolyte. If it seems slushy or like ice, do not try jump starting until it thaws.

### NOTICE

*If a battery sits in extreme cold, the electrolyte inside can freeze. Attempting to jump start with a frozen battery can cause it to rupture.*

2. Turn off all the electrical accessories: heater, A/C, stereo system, lights, etc.  
Put the transmission in Neutral or Park and set the parking brake.

CONTINUED

## Jump Starting

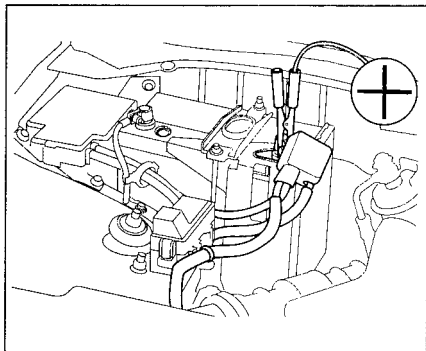

3. Connect one jumper cable to the positive (+) terminal on the booster battery. Connect the other end to the positive (+) terminal on your Honda's battery.

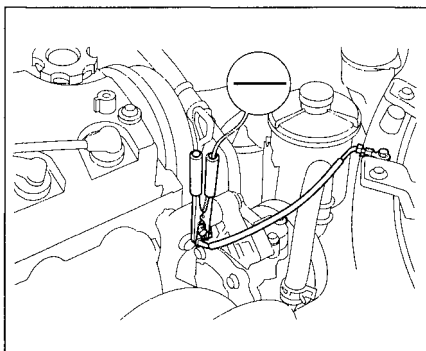

4. Connect the second jumper cable to the negative ( — ) terminal on the booster battery. Connect the other end to the grounding strap as shown. Do not connect this jumper cable to any other part of the engine.

5. If the booster battery is in another car, have an assistant start that car and run it at a fast idle.

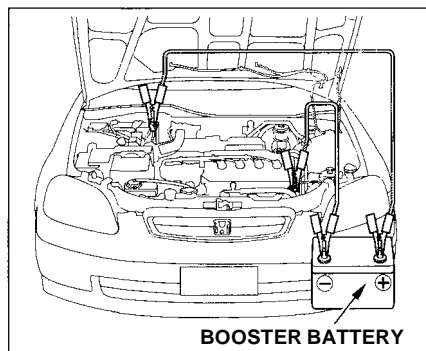

6. Start your car. If the starter motor still operates slowly, check the jumper cable connections to make sure they have good metal-to-metal contact.

7. Once your car is running, disconnect the negative cable from your car, then from the booster battery. Disconnect the positive cable from your car, then the booster battery.

The pointer of your car's temperature gauge should stay in the mid-range under most conditions. It may go higher if you are driving up a long steep hill on a very hot day. If it climbs to the red mark, you should determine the reason.

### NOTICE

*Driving with the temperature gauge pointer at the red mark can cause serious damage to your engine.*

Your car can overheat for several reasons, such as lack of coolant or a mechanical problem. The only indication may be the temperature gauge climbing to or above the red mark. Or you may see steam or spray coming from under the hood. In either case, you should take immediate action.

Steam and spray from an overheated engine can seriously scald you.

Do not open the hood if steam is coming out.

1. Safely pull to the side of the road. Put the transmission in Neutral or Park and set the parking brake. Turn off the heating and cooling system and all other accessories. Turn on the hazard warning indicators.
2. If you see steam and/or spray coming from under the hood, turn off the engine.
3. If you do not see steam or spray, leave the engine running and watch the temperature gauge. If the high heat is due to overloading (climbing a long, steep hill on a hot day with the A/C running, for example), the engine should start to cool down almost immediately. If it does, wait until the temperature gauge comes down to the mid-point then continue driving.

CONTINUED

## If Your Engine Overheats

---

4. If the temperature gauge stays at the red mark, turn off the engine.
5. Wait until you see no more signs of steam or spray, then open the hood.
6. Look for any obvious coolant leaks, such as a split radiator hose. Everything is still extremely hot, so use caution. If you find a leak, it must be repaired before you continue driving (see **Towing** on page 200).
7. If you don't find an obvious leak, check the coolant level in the radiator reserve tank (see page 95 ). If the level is below the MIN mark, add coolant to halfway between the MIN and MAX marks.
8. If there was no coolant in the reserve tank, you may also have to add coolant to the radiator. Let the engine cool down until the pointer

reaches the middle of the temperature gauge, or lower, before checking the radiator.

Removing the radiator cap while the engine is hot can cause the coolant to spray out, seriously scalding you.

Always let the engine and radiator cool down before removing the radiator cap.

9. Using gloves or a large heavy cloth, turn the radiator cap counterclockwise, without pushing down, to the first stop. This releases any remaining pressure in the cooling system. After the pressure releases, push down on the cap and turn it until it comes off.

10. Start the engine and set the temperature control lever to maximum. Add coolant to the radiator up to the base of the filler neck. If you do not have the proper coolant mixture available, you can add plain water. Remember to have the cooling system drained and refilled with the proper mixture as soon as you can.

11. Put the radiator cap back on tightly. Run the engine and watch the temperature gauge. If it goes back to the red mark, the engine needs repair. (See **Towing** on page 200.)

12. If the temperature stays normal, check the coolant level in the radiator reserve tank. If it has gone down, add coolant to the MAX mark. Put the cap back on tightly.

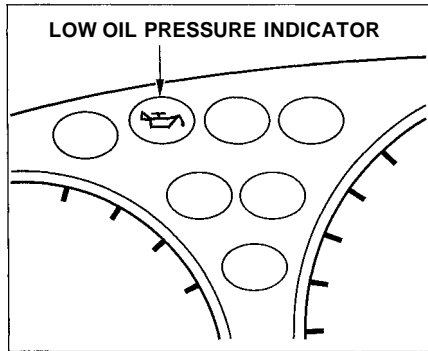

This indicator should light when the ignition is ON (II), and go out after the engine starts. It should never come on when the engine is running. If it starts flashing, it indicates that the oil pressure dropped very low for a moment, then recovered. If the indicator stays on with the engine running, it shows that the engine has lost oil pressure and serious engine damage is possible. In either case, you should take immediate action.

## NOTICE

*Running the engine with low oil pressure can cause serious mechanical damage almost immediately. Turn off the engine as soon as you can safely get the car stopped.*

1. Safely pull off the road and shut off the engine. Turn on the hazard warning indicators.
2. Let the car sit for a minute. Open the hood and check the oil level (see page 94). Although oil level and oil pressure are not directly connected, an engine that is very low on oil can lose pressure during cornering and other driving maneuvers.
3. If necessary, add oil to bring the level back to the full mark on the dipstick (see page 132).
4. Start the engine and watch the oil pressure indicator. If the light does not go out within ten seconds, turn off the engine. There is a mechanical problem that needs to be repaired before you can continue driving. (See **Towing** on page 200.)

## Charging System Indicator

---

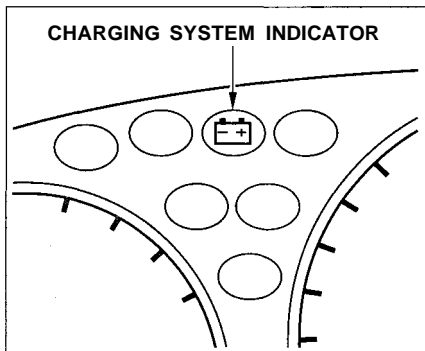

This indicator should come on when the ignition is ON (II), and go out after the engine starts. If it comes on brightly when the engine is running, it indicates that the charging system has stopped charging the battery.

Immediately turn off all electrical accessories: radio, heater, A/C, rear defogger, cruise control, etc. Try not to use other electrically-operated controls such as the power windows. Keep the engine running and take extra care not to stall it. Starting the engine will discharge the battery rapidly.

By eliminating as much of the electrical load as possible, you can drive several miles before the battery is too discharged to keep the engine running. Drive to a service station or garage where you can get technical assistance.

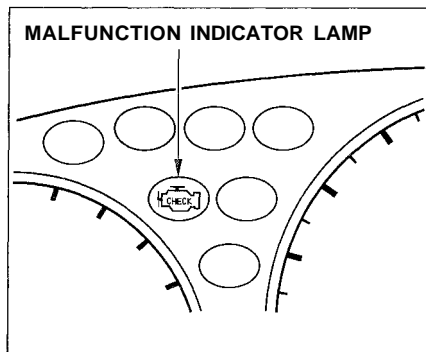

This indicator comes on for a few seconds when you turn the ignition switch ON (II). If it comes on at any other time, it indicates one of the engine's emissions control systems may have a problem. Even though you may feel no difference in your car's performance, it can reduce your fuel economy and cause your car to put out excessive emissions. Continued operation may cause serious damage.

If you have recently refueled your vehicle, the cause of this indicator coming on could be a loose or missing fuel fill cap. Check the cap and tighten it until it clicks. Replace the fuel fill cap if it is missing. Tightening the cap will not make the indicator turn off immediately; it takes three driving trips.

If the indicator remains on past three driving trips, or the fuel cap was not loose or missing, have the vehicle checked by the dealer as soon as possible. Drive moderately until the dealer has inspected the problem. Avoid full-throttle acceleration and driving at high speed.

You should also have the dealer inspect your vehicle if this indicator comes on repeatedly, even though it may turn off as you continue driving.

## NOTICE

*If you keep driving with the malfunction indicator lamp on, you can damage your car's emission controls and engine. Those repairs may not be covered by your car's warranties.*



## Closing the Moonroof

If the electric motor will not close the moonroof, do the following:

1. Check the fuse for the moonroof motor (see page 195). If the fuse is blown, replace it with one of the same or lower rating.
2. Try closing the moonroof. If the new fuse blows immediately or the moonroof motor still does not operate, you can close the moonroof manually.
3. Get the tool out of the tool kit in the trunk.

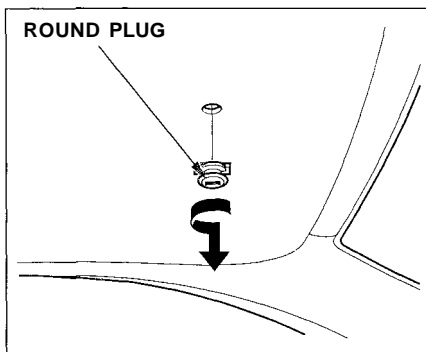

4. Use a screwdriver or coin to remove the round plug in the center of the headliner.

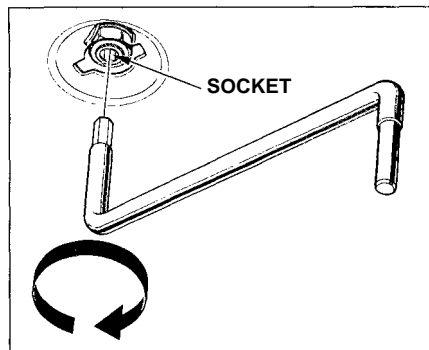

5. Insert the moonroof wrench into the socket behind this plug. Turn the wrench until the moonroof is fully closed.
6. Remove the wrench. Replace the round plug.

All the electrical circuits in your car have fuses to protect them from a short circuit or overload. These fuses are located in two or three fuse boxes.

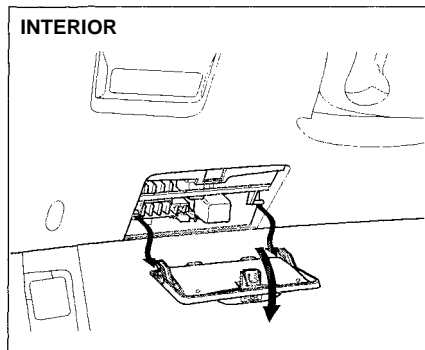

The interior fuse box is underneath the dashboard on the driver's side. Remove the fuse box lid by swinging the lid down and pulling it straight out of its hinges.

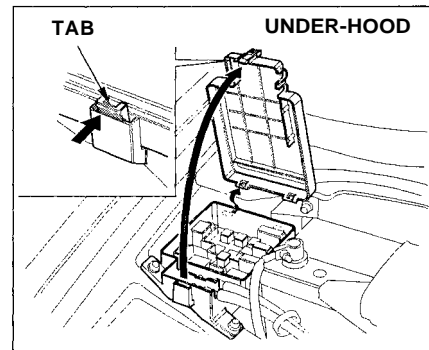

The under-hood fuse box is located in the engine compartment next to the battery. To open it, push the tab as shown.

*CONTINUED*

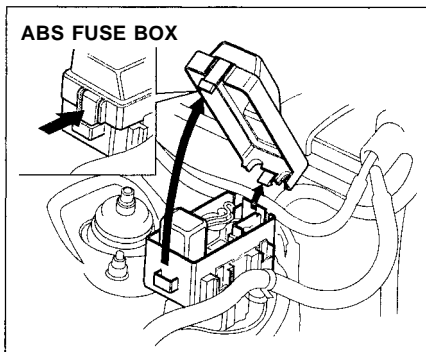

Cars equipped with ABS have a third fuse box for the ABS. It is in the engine compartment on the passenger's side.

## Checking and Replacing Fuses

If something electrical in your car stops working, the first thing you should check for is a blown fuse. Determine from the chart on pages 198 and 199, or the diagram on the fuse box lid, which fuse or fuses control that component. Check those fuses first, but check all the fuses before deciding that a blown fuse is not the cause. Replace any blown fuses and check the component's operation.

1. Turn the ignition switch to LOCK (0). Make sure the headlights and all other accessories are off.
2. Remove the cover from the fuse box.

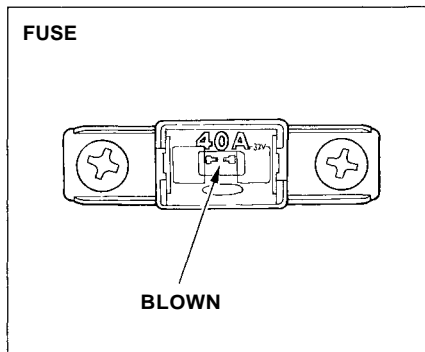

3. Check each of the large fuses in the under-hood fuse box by looking through the top at the wire inside. Removing these fuses requires a Phillips-head screwdriver.

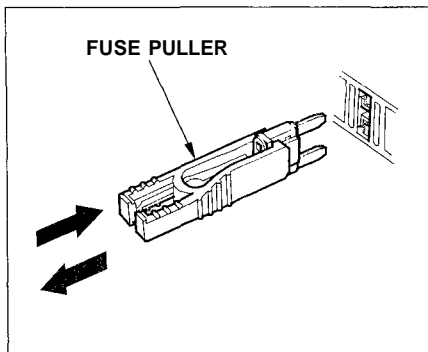

4. Check the smaller fuses in the under-hood fuse box and all the fuses in the interior fuse box by pulling out each fuse with the fuse puller provided in the interior fuse box.

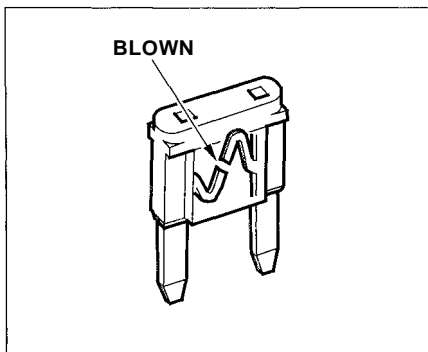

5. Look for a burned wire inside the fuse. If it is burned, replace it with one of the spare fuses of the same rating or lower.

If you cannot drive the car without fixing the problem, and you do not have a spare fuse, take a fuse of the same rating or a lower rating from one of the other circuits. Make sure you can do without that circuit temporarily (such as the accessory socket or radio).

If you replace the blown fuse with a spare fuse that has a lower rating, it might blow out again. This does not indicate anything wrong. Replace the fuse with one of the correct rating as soon as you can.

#### NOTICE

*Replacing a fuse with one that has a higher rating greatly increases the chances of damaging the electrical system. If you do not have a replacement fuse with the proper rating for the circuit, install one with a lower rating.*

6. If the replacement fuse of the same rating blows in a short time, there is probably a serious electrical problem in your car. Leave the blown fuse in that circuit and have your car checked by a qualified technician.

CONTINUED

## INTERIOR FUSE BOX

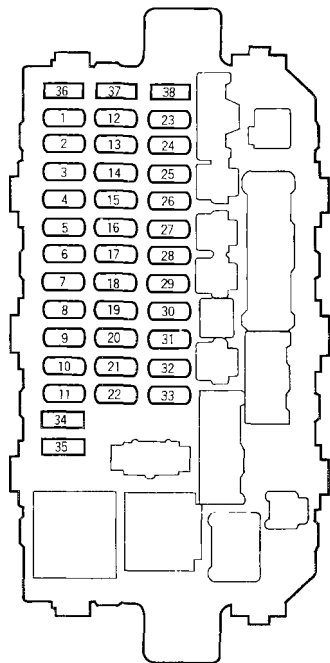

No.	Amps.	Circuits Protected
1	--	Not Used
2	--	Not Used
3	--	Not Used
4	10 A	Right Headlight High Beam
5	10 A	Left Headlight High Beam
6	--	Not Used
7	--	Not Used
8	--	Not Used
9	15 A	Ignition Coil
10	20 A	Front Right Power Window
11	20 A	Front Left Power Window
12	7.5 A	Turn Signal Lights
13	15 A	Fuel Pump (SRS Unit)
14	7.5 A	Cruise Control, Keyless
15	7.5 A	Alternator, SP Sensor
16	7.5 A	Rear Defroster Relay
17	7.5 A	Heater, Air Conditioning Relay
18	7.5 A	Daytime Running Lights Relay*
19	7.5 A	Back-up Lights
20	10 A	Daytime Running Lights*

No.	Amps.	Circuits Protected
21	10 A	Right Headlight Low Beam
22	10 A	Left Headlight Low Beam
23	10 A	SRS
24	7.5 A	Power Window Relay, Moonroof Relay
25	7.5 A	Meter
26	20 A	Front Wiper, Front Washer
27	10 A	Accessory Socket
28	10 A	Radio, Clock
29	--	Not Used
30	7.5 A	Instrument Lights
31	7.5 A	Starter Signal
32	7.5 A	License Plate Lights, Taillights
33	7.5 A	Inter Lock Unit
34	20 A	Spare Fuse
35	7.5 A	Spare Fuse
36	--	Not Used
37	10 A	Spare Fuse
38	15 A	Spare Fuse

\* : On Canadian cars

## UNDER-HOOD FUSE BOX

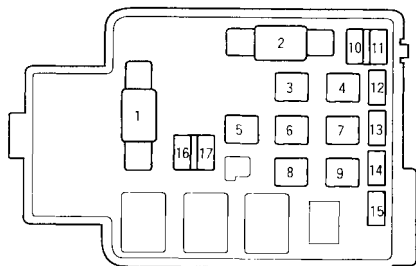

No.	Amps.	Circuits Protected
1	80 A	Battery
2	40 A	Ignition 1
3		Not Used
4	40 A	Power Window
5	30 A	Headlight, Small Light
6		Not Used
7	30 A	Rear Defroster
8	40 A	Option

No.	Amps.	Circuits Protected
9	40 A	Heater Motor
10	7.5 A	Interior Light
11	15 A	FI E/M (ECM/PCM)
12	7.5 A	Back Up, Radio
13	20 A	Door Lock Unit, Moonroof
14	20 A	Magnetic Clutch (A/C), Condenser Fan (A/C)
15	20 A	Cooling Fan
16	15 A	Horn, Stop Light
17	10 A	Hazard

## ABS FUSE BOX

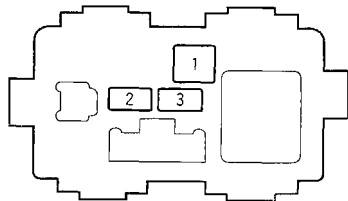

No.	Amps.	Circuits Protected
1	40 A	ABS Pump Motor
2	20 A	ABS + B
3	7.5 A	Motor Check

If your car needs to be towed, call a professional towing service or, if you belong to one, an organization that provides roadside assistance. Never tow your car behind another car with just a rope or chain. It is very dangerous.

## Emergency Towing

There are three popular methods of towing a car:

**Flat-bed Equipment** — The operator loads your car on the back of a truck. **This is the best way of transporting your Honda.**

**Wheel Lift Equipment** — The tow truck uses two pivoting arms that go under the tires (front or rear) and lift them off the ground. The other two tires remain on the ground.

**Sling-type Equipment** — The tow truck uses metal cables with hooks on the ends. These hooks go around parts of the frame or suspension and the cables lift that end of the car off the ground. Your car's suspension and body can be seriously damaged if this method of towing is attempted.

If your Honda cannot be transported by flat-bed, it should be towed with the front wheels off the ground. If due to damage, your car must be towed with the front wheels on the ground, do the following:

*5-speed Manual Transmission and Continuously Variable Transmission (CVT)*

- Release the parking brake.
  - Shift the transmission to Neutral.
- Automatic Transmission:*
- Release the parking brake.
  - Start the engine.
  - Shift to D<sub>4</sub>, then to N.
  - Turn off the engine.

## NOTICE

*Improper towing preparation will damage the transmission. Follow the above procedure exactly. If you cannot shift the transmission or start the engine (automatic transmission), your car must be transported, on a flat-bed.*

- It is best to tow the car no farther than 50 miles (80 km), and keep the speed below 35 mph (55 km/h).
- If your car is equipped with a front spoiler, remove it before towing so it is not damaged.

## NOTICE

*Trying to lift or tow your car by the bumpers will cause serious damage. The bumpers are not designed to support the car's weight.*

The diagrams in this section give you the dimensions and capacities of your Honda, and the locations of the identification numbers. The explanations of several electronic and mechanical systems on your Honda are for the more technically-oriented owner.

Identification Numbers.....	202
Specifications.....	204
Tire Information.....	206
Tire Size Designation.....	206
Wheel Size Designation.....	206
Tire Speed Ratings.....	206
Tire Pressure Adjustment For High Speed Driving.....	207
DOT Tire Quality Grading.....	207
Treadwear.....	207
Traction.....	208
Temperature.....	208

Emission Controls.....	209
The Clean Air Act.....	209
Crankcase Emission Control System.....	209
Evaporative Emission Control System.....	209
Exhaust Emission Controls.....	210
PGM-FI System.....	210
Ignition Timing Control System.....	210
Exhaust Gas Recirculation (EGR) System.....	210
Three Way Catalytic Converter.....	210
Replacement Parts.....	210
Three Way Catalytic Converter...	211



## Identification Numbers

Your car has several identifying numbers located in various places.

The Vehicle Identification Number (VIN) is the 17-digit number your Honda dealer uses to register your car for warranty purposes. It is also necessary for licensing and insuring your car. The easiest place to find the VIN is on a plate fastened to the top of the dashboard. You can see it by looking through the windshield on the driver's side. It is also on the Certification label attached to the driver's doorjamb, and is stamped on the engine compartment bulkhead. The VIN is also provided in bar code on the Certification label.

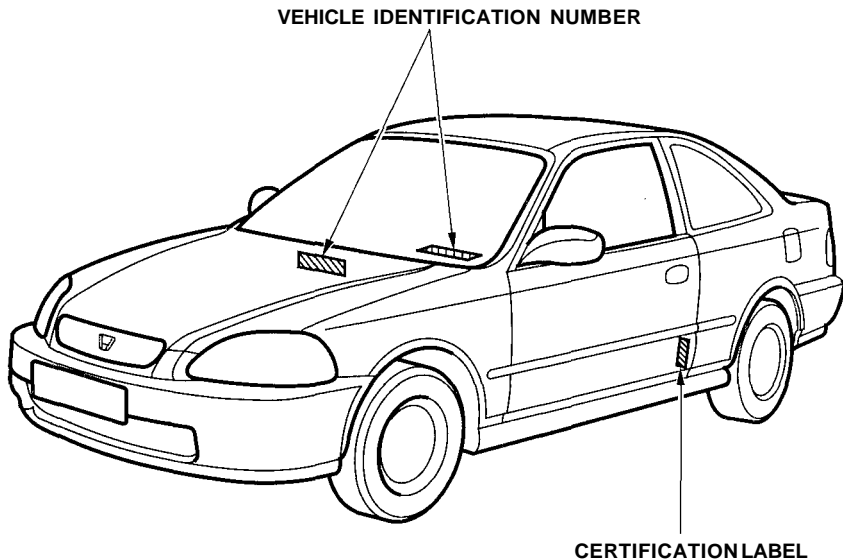

The Engine Number is stamped into the engine block.

The Transmission Number is on a label on top of the transmission.

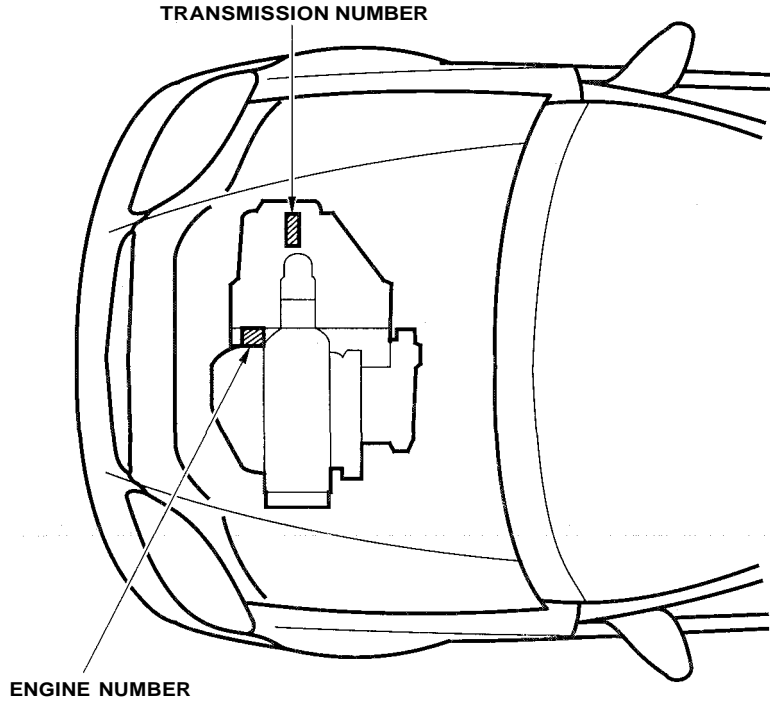

# Specifications

## Dimensions

Length		4,450 mm (175.2 in)
Width		1,705 mm (67.1 in)
Height		1,375 mm (54.1 in)
Wheelbase		2,620 mm (103.1 in)
Track	Front	1,475 mm (58.1 in)
	Rear	1,475 mm (58.1 in)

## Weights

Gross vehicle weight rating	See the certification label attached to the driver's doorjamb.
-----------------------------	--

## Engine

Type	Water cooled 4-stroke SOHC <sup>*1</sup> , SOHC VTEC <sup>*2</sup> 4-cylinder gasoline engine
Bore x Stroke	75.0 x 90.0 mm (2.95 x 3.54 in)
Displacement	1,590 cm <sup>3</sup> (97.0 cu-in)
Compression ratio	9.4 : 1 <sup>*5</sup>
	9.6 : 1 <sup>*6</sup>
Spark plugs	See spark plug maintenance section page 149.

\* 1 : DX

\* 2 : U.S.: HX, EX, Canada: Si

\* 3 : U.S.: DX, HX, Canada: DX

\* 4 : U.S.: EX, Canada: Si

## Capacities

Fuel tank		Approx. 45 ℓ (11.9 US gal , 9.9 Imp gal)
Engine coolant	Change <sup>*1</sup>	
	Manual	3.1 ℓ (0.82 US gal , 0.68 Imp gal)
	Automatic	3.0 ℓ (0.79 US gal , 0.66 Imp gal) <sup>*2</sup> 3.2 ℓ (0.85 US gal , 0.70 Imp gal) <sup>*3</sup>
	Total	
	Manual	4.2 ℓ (1.11 US gal , 0.92 Imp gal)
	Automatic	4.1 ℓ (1.08 US gal , 0.90 Imp gal) <sup>*2</sup> 4.3 ℓ (1.14 US gal , 0.95 Imp gal) <sup>*3</sup>
Engine oil	Change <sup>*4</sup>	
	Including filter	3.3 ℓ (3.5 US qt , 2.9 Imp qt) <sup>*2</sup> 3.6 ℓ (3.8 US qt , 3.2 Imp qt) <sup>*3</sup>
	Without filter	3.0 ℓ (3.2 US qt , 2.6 Imp qt) <sup>*2</sup> 3.3 ℓ (3.5 US qt , 2.9 Imp qt) <sup>*4</sup>
	Total	4.0 ℓ (4.2 US qt , 3.5 Imp qt)
Manual transmission fluid	Change	1.8 ℓ (1.9 US qt , 1.6 Imp qt)
	Total	1.9 ℓ (2.0 US qt , 1.7 Imp qt)
Automatic transmission fluid	Change	2.7 ℓ (2.9 US qt , 2.4 Imp qt)
	Total	3.9 ℓ (4.1 US qt , 3.4 Imp qt) <sup>*6</sup>
		5.9 ℓ (6.2 US qt , 5.2 Imp qt) 6.3 ℓ (6.7 US qt , 5.5 Imp qt) <sup>*6</sup>
Windshield washer reservoir		2.5 ℓ (2.6 US qt , 2.2 Imp qt)
		4.5 ℓ (4.8 US qt , 4.0 Imp qt) <sup>*5</sup>

\* 1 : Including the coolant in the reserve tank and that remaining in the engine.

Reserve tank capacity: 0.4ℓ (0.11 US gal, 0.09 Imp gal)

\* 2 : DX \* 3 : U.S.: HX, EX, Canada: Si

\* 4 : Excluding the oil remaining in the engine.

\* 5 : Canadian Cars \* 6 : U.S.: HX (CVT)

## Air Conditioning

Refrigerant type	HFC-134a (R-134a)
Charge quantity	600 – 650 g (21.2 – 22.9 oz)
Lubricant type	SP-10

## Lights

Headlights (HI/LO)	12 V – 60/55W (HB2)
Front turn signal/side marker/ parking lights	12 V – 43/3 CP (SAE 3496)
Rear turn signal lights	12 V – 21 W
Stop/Taillights/Rear side marker lights	12 V – 21/5 W
Back-up lights	12 V – 21 W
High-mount brake light	12 V – 21 W
License plate lights	12 V – 3 CP
Interior light	12 V – 5 W *1 12 V – 8 W *2
Trunk light	12 V – 3.4 W

\* 1 : Without moonroof

\* 2 : With moonroof

## Battery

Capacity	12 V – 38 AH/5 HR 12 V – 47 AH/20 HR
----------	---

## Fuses

Interior	See page 198 or the fuse label attached to the inside of the fuse box door under the dashboard.
Under-hood	See page 199 or the fuse box cover.

## Alignment

Toe-in	Front	1.0 mm (0.04 in)
	Rear	2.0 mm (0.08 in)
Camber	Front	0°
	Rear	-1°
Caster	Front	1°40'

## Tires

Size	Front/Rear	P185/65R14 85S
	Spare	T105/80D13 82M *1
		T105/70D14 83M *2
		T125/70D14 93M *3
Pressure	Front	210 kPa (2.1 kgf/cm <sup>2</sup> , 30 psi)
	Rear	200 kPa (2.0 kgf/cm <sup>2</sup> , 29 psi)
	Spare	420 kPa (4.2 kgf/cm <sup>2</sup> , 60 psi)

\* 1 : U.S. DX, HX, Canada: DX

\* 2 : U.S. EX without ABS, Canada: Si without ABS

\* 3 : U.S. EX with ABS, Canada: Si with ABS

# Tire Information

## Tire Size Designation

A tire's sidewall is marked with a tire size designation. You will need this information when selecting replacement tires for your car. The following explains what the letters and numbers in the tire size designation mean.

(Example tire size designation)  
P185/65R14 85S

**P** — Applicable vehicle type (tires marked with the prefix "P" are intended for use on passenger cars; however, not all tires have this marking).

**185** — Tire width in millimeters.

**65** — Aspect ratio. The tire's section height as a percentage of its width.

**R** — Tire construction code (Radial).

**14** — Rim diameter in inches.

**85** — Load Index, a numerical code associated with the maximum load the tire can carry.

**S** — Speed Rating Symbol. See the speed rating chart in this section for additional information.

## Wheel Size Designation

Wheels are also marked with important information that you need if you ever have to replace one. The following explains what the letters and numbers in the wheel size designation mean.

(Example wheel size designation)  
14 x 5 J

**14** — Rim diameter in inches.

**5** — Rim width in inches.

**J** — Rim contour designation.

## Tire Speed Ratings

The chart below shows many of the different speed ratings currently being used for passenger car tires. The speed rating symbol is part of the tire size designation on the sidewall of the tire. This symbol corresponds to that tire's designed maximum safe operating speed.

Speed Rating Symbol	Maximum Speed
S	112 mph (180 km/h)
T	118 mph (190 km/h)
H	130 mph (210 km/h)
V	149 mph (240 km/h)
Z	Above 149 mph (240 km/h)

### Tire Pressure Adjustment For High Speed Driving

Honda strongly recommends that you not drive faster than posted speed limits and conditions allow. If you decide it is safe to drive at high speeds, be sure to adjust the cold tire pressures as shown below. If you do not adjust the tire pressure, excessive heat can build up and cause sudden tire failure.

Tire Size	Cold Tire Pressure for Speeds over 100 mph (160 km/h)
P185/65R14 85S	Front: 250 kPa (2.5 kgf/cm <sup>2</sup> , 36 psi) Rear: 240 kPa (2.4 kgf/cm <sup>2</sup> , 35 psi)

Be sure to readjust the pressure for normal driving speeds. You should wait until the tires are cold before adjusting the tire pressure (see page 157).

### DOT Tire Quality Grading (U.S. Cars)

The tires on your car meet all U.S. Federal Safety Requirements. All tires are also graded for treadwear, traction, and temperature performance according to Department of Transportation (DOT) standards. The following explains these gradings.

#### *Treadwear*

The treadwear grade is a comparative rating based on the wear rate of the tire when tested under controlled conditions on a specified government test course. For example, a tire graded 150 would wear one and one half (1-1/2) times as well on the government course as a tire graded 100. The relative performance of tires depends upon the actual conditions of their use, however, and may depart significantly from the norm due to variations in driving habits, service practices and differences in road characteristics and climate.

CONTINUED

### ***Traction***

The traction grades, from highest to lowest, are A, B, and C, and they represent the tire's ability to stop on wet pavement as measured under controlled conditions on specified government test surfaces of asphalt and concrete. A tire marked C may have poor traction performance.

Warning: The traction grade assigned to this tire is based on braking (straight ahead) traction tests and does not include cornering (turning) traction.

### ***Temperature***

The temperature grades are A (the highest), B, and C, representing the tire's resistance to the generation of heat and its ability to dissipate heat when tested under controlled conditions on a specified indoor laboratory test wheel. Sustained high temperature can cause the material of the tire to degenerate and reduce tire life, and excessive temperature can lead to sudden tire failure. The grade C corresponds to a level of performance which all passenger car tires must meet under the Federal Motor Vehicle Safety Standard No. 109. Grades B and A represent higher levels of performance on the laboratory test wheel than the minimum required by law.

Warning: The temperature grade for this tire is established for a tire that is properly inflated and not overloaded. Excessive speed, underinflation, or excessive loading either separately or in combination, can cause heat build-up and possible tire failure.

The burning of gasoline in your car's engine produces several byproducts. Some of these are carbon monoxide (CO), oxides of nitrogen (NOx) and hydrocarbons (HC). Gasoline evaporating from the tank also produces hydrocarbons. Controlling the production of NOx, CO, and HC is important to the environment. Under certain conditions of sunlight and climate, NOx and HC react to form photochemical "smog." Carbon monoxide does not contribute to smog creation, but it is a poisonous gas.

### **The Clean Air Act**

The United States Clean Air Act\* sets standards for automobile emissions. It also requires that automobile manufacturers explain to owners how their emission controls work and what to do to maintain them. This section summarizes how the emission controls work. Scheduled maintenance is on page [126](#).

\* In Canada, Honda vehicles comply with the Canadian Motor Vehicle Safety Standards (CMVSS) for Emissions valid at the time they are manufactured.

### **Crankcase Emission Control System**

Your car has a Positive Crankcase Ventilation System. This keeps gasses that build up in the engine's crankcase from going into the atmosphere. The Positive Crankcase Ventilation valve routes them from the crankcase back to the intake manifold. They are then drawn into the engine and burned.

### **Evaporative Emission Control System**

As gasoline evaporates in the fuel tank, an evaporative emission control canister filled with charcoal adsorbs the vapor. It is stored in this canister while the engine is off. After the engine is started and warmed up, the vapor is drawn into the engine and burned during driving.



## **Exhaust Emission Controls**

The exhaust emission controls include three systems: PGM-FI, Ignition Timing Control and Three Way Catalytic Converter. These three systems work together to control the engine's combustion and minimize the amount of HC, CO, and NOx that comes out the tailpipe. The exhaust emission control systems are separate from the crankcase and evaporative emission control systems.

### ***PGM-FI System***

The PGM-FI System uses sequential multiport fuel injection. It has three subsystems: Air Intake, Engine Control, and Fuel Control. The Engine Control Module (ECM)/ Powertrain Control Module (PCM-A/T only) uses various sensors to determine how much air is going into the engine. It then controls how much fuel to inject under all operating conditions.

### ***Ignition Timing Control System***

This system constantly adjusts the ignition timing, reducing the amount of HC, CO and NOx produced.

### ***Exhaust Gas Recirculation (EGR) System***

*Only on HX model*

The Exhaust Gas Recirculation (EGR) system takes some of the exhaust gas and routes it back into the intake manifold. Adding exhaust gas to the air/fuel mixture reduces the amount of NOx produced when the fuel is burned.

### ***Three Way Catalytic Converter***

The three way catalytic converter is in the exhaust system. Through chemical reactions, it converts HC, CO, and NOx in the engine's exhaust to carbon dioxide (CO<sub>2</sub>), dinitrogen (N<sub>2</sub>), and water vapor.

## **Replacement Parts**

The emission control systems are designed and certified to work together in reducing emissions to levels that comply with the Clean Air Act. To make sure the emissions remain low, you should use only new Genuine Honda replacement parts or their equivalent for repairs. Using lower quality parts may increase the emissions from your car.

The emissions control systems are covered by warranties separate from the rest of your car. Read your warranty manual for more information.

The three way catalytic converter contains precious metals that serve as catalysts, promoting chemical reactions to convert the exhaust gasses without affecting the metals. The catalytic converter is referred to as a three-way catalyst, since it acts on HC, CO, and NOx. A replacement unit must be an original Honda part or its equivalent.

The three way catalytic converter must operate at a high temperature for the chemical reactions to take place. It can set on fire any combustible materials that come near it. Park your car away from high grass, dry leaves, or other flammables.

(U.S.: EX, Canada: Si)

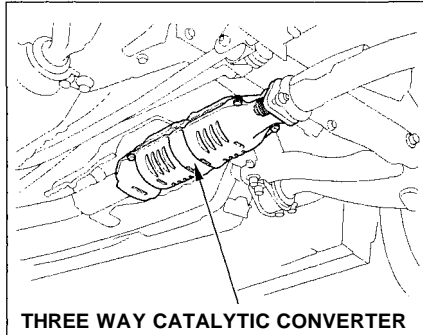

A defective three way catalytic converter contributes to air pollution, and can impair your engine's performance. Follow these guidelines to protect your car's three way catalytic converter.

- Always use unleaded gasoline. Even a small amount of leaded gasoline can contaminate the catalyst metals, making the three way catalytic converter ineffective.

(U.S.: DX, HX, Canada: DX)

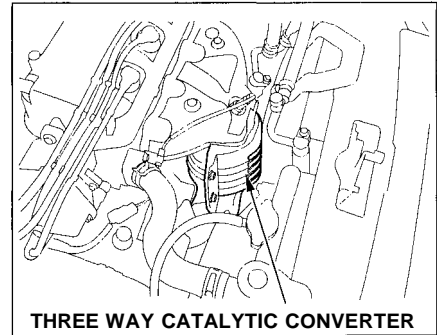

- Keep the engine tuned-up.
- Have your car diagnosed and repaired if it is misfiring, back-firing, stalling, or otherwise not running properly.

Customer Relations	
Information.....	214
U.S. Zone Office Map.....	215
Canada Zone Office Map.....	216
Warranty Coverages.....	217
Reporting Safety Defects (U.S. Cars).....	218
Authorized Manuals.....	219

## Customer Relations Information

---

Honda dealership personnel are trained professionals. They should be able to answer all your questions. If you encounter a problem that your dealership does not solve to your satisfaction, please discuss it with the dealership's management. The Service Manager or General Manager can help. Almost all problems are solved in this way.

If you are dissatisfied with the decision made by the dealership's management, contact your Honda Customer Relations Zone Office. Refer to the U.S. and Canadian Zone Office maps on the following pages.

When you call or write, please give us this information:

- Vehicle Identification Number (see page 202)
- Name and address of the dealer who services your car
- Date of purchase
- Mileage on your car
- Your name, address, and telephone number
- A detailed description of the problem
- Name of the dealer who sold the car to you

### **U.S. Owners**

Your new Honda is covered by these warranties:

***New Car Limited Warranty*** — covers your new car, except for the battery, emissions control systems and accessories, against defects in materials and workmanship.

***Emissions Control Systems Defects Warranty and Emissions Performance Warranty*** — these two warranties cover your car's emissions control systems. Time, mileage, and coverage are conditional. Please read the warranty manual for exact information.

***Original Equipment Battery Limited Warranty*** — this warranty gives up to 100 percent credit toward a replacement battery.

***Seat Belt Limited Warranty*** — a seat belt that fails to function properly is covered for the useful life of the car.

***Rust Perforation Limited Warranty*** — all exterior body panels are covered for rust-through from the inside for the specified time period with no mileage limit.

***Accessory Limited Warranty*** — Genuine Honda Accessories are covered under this warranty. Time and mileage limits depend on the type of accessory and other factors. Please read your warranty manual for details.

***Replacement Parts Limited Warranty*** — covers all Genuine Honda replacement parts against defects in materials and workmanship.

***Replacement Battery Limited Warranty*** — provides prorated coverage for a replacement battery purchased from a Honda dealer.

***Replacement Muffler Lifetime Limited Warranty*** — provides coverage for as long as the purchaser of the muffler owns the car.

Restrictions and exclusions apply to all these warranties. Please read the 1997 Honda Warranties booklet that came with your car for precise information on warranty coverages. Your Honda's original tires are covered by their manufacturer. Tire warranty information is in a separate booklet.

### **Canadian Owners**

Please refer to the 1997 Warranty Manual that came with your car.

## Reporting Safety Defects (U.S. Cars)

---

If you believe that your vehicle has a defect which could cause a crash or could cause injury or death, you should immediately inform the National Highway Traffic Safety Administration (NHTSA) in addition to notifying American Honda Motor Co., Inc.

If NHTSA receives similar complaints, it may open an investigation, and if it finds that a safety defect exists in a group of vehicles, it may order a recall and remedy campaign. However, NHTSA cannot become involved in individual problems between you, your dealer, or American Honda Motor Co., Inc.

To contact NHTSA, you may either call the Auto Safety Hotline toll-free at 1-800-424-9393 (or 366-0123 in Washington D.C. area) or write to: NHTSA, U.S. Department of Transportation, Washington, D.C. 20590. You can also obtain other information about motor vehicle safety from the Hotline.

## A

Accessories	
Installation.....	97
ACCESSORY (Ignition Key Position).....	50
Accessory Power Socket.....	65
Adding	
Automatic Transmission Fluid.....	142
Brake Fluid.....	144
Clutch Fluid.....	144
Engine Coolant.....	136
Engine Oil.....	132
Manual Transmission Fluid....	143
Power Steering Fluid.....	145
Windshield Washer Fluid.....	141
Additional Safety Information.....	18
Door Locks.....	19
Driving with Pets.....	19
Head Restraint Position.....	18
Seat-back Position.....	18
Storing Cargo Safely .....	19
Additives, Engine Oil.....	133
Adjustments	
Headlights.....	162

Head Restraints.....	57
Mirrors.....	61
Seats.....	56
Steering Wheel.....	45
Airbag (SRS).....	12
Air Cleaner Element.....	146
Air Conditioning.....	68
Maintenance.....	154
Usage.....	68
Air Outlets (Vents).....	70
Air Pressure, Tires.....	156
Normal Driving.....	157
High Speed Driving.....	207
Alcohol and Drugs.....	27
Alcohol in Gasoline.....	90
Antifreeze.....	136
Anti-lock Brakes (ABS)	
Indicator Light.....	35, 117
Operation.....	115
Anti-theft Steering Column Lock.....	50
Appearance Care.....	173
Ashtrays (Optional).....	65
Audio System.....	76
Automatic Speed Control.....	46

Automatic Transmission.....	104
Capacity, Fluid.....	204
Checking Fluid Level.....	141
Shifting.....	105
Shift Lever Position Indicator.....	104, 109
Shift Lever Positions.....	104, 109
Shift Lock Release.....	108

## B

Battery	
Charging System Indicator.....	35, 192
Jump Starting.....	187
Maintenance.....	150
Specifications.....	205
Before Driving.....	89
Belts, Seat.....	5
Beverage Holder.....	64
Body Repair.....	178

CONTINUED

Brakes			
Anti-lock System (ABS).....	115	Trunk Light.....	171
Break-in, New Linings.....	90	Turn Signal Lights.....	166
Fluid.....	143	Bulbs, Halogen.....	164
Light, Burned-out.....	167		
Parking.....	62	<b>C</b>	
System Indicator.....	35	Cables, Jump Starting With.....	187
Wear Indicators.....	114	Capacities Chart.....	204
Brakes, ABS		Carbon Monoxide Hazard.....	28
Operation.....	115	Cargo, Loading.....	98
System Indicator.....	35, 117	Cassette Player	
Braking System.....	114	Care.....	84
Break-in, New Car.....	90	Operation.....	82
Brightness Control, Instruments...	42	CAUTION, Explanation of.....	ii
Blights, Headlights.....	41	CD Changer.....	85
Bulb Replacement		CD Changer/Player.....	85
Back-up Lights.....	168	Certification Label.....	202
Brake Lights.....	167	Chains.....	161
Front Parking Lights.....	166	Change Oil	
Front Side Marker Lights.....	166	How to.....	134
Headlights.....	164	When to.....	126
High-mount Brake Light.....	169	Changing a Flat Tire.....	181
Interior Light.....	170	Changing Engine Coolant.....	138
License Plate Lights.....	170	Charging System Indicator ...	35, 192
Rear Side Marker Lights.....	167		
Specifications.....	205	Checking	
		Automatic Transmission	
		Fluid.....	141
		Battery Condition.....	150
		Brake Fluid.....	144
		Clutch Fluid.....	144
		Drive Belts.....	155
		Engine Coolant.....	95
		Engine Oil.....	94
		Fuses.....	196
		Manual Transmission Fluid .....	143
		Power Steering Fluid.....	145
		Checklist, Before Driving.....	100
		Child Safety.....	20
		Cleaner, Air.....	146
		Cleaning	
		Exterior.....	174
		Interior.....	176
		Seat Belts.....	176
		Vinyl.....	176
		Windows.....	177
		Clock, Setting the .....	81
		Clutch Fluid.....	144
		CO in the Exhaust.....	209
		Cold Weather, Starting in.....	101
		Compact Spare.....	180



Consumer Information* .....	214
Continuously Variable Transmission (CVT).....	109
Fluid.....	142
Shift Lever Position Indicator..	109
Shift Lever Positions.....	109
Controls, Instruments and.....	31
Coolant	
Adding.....	136
Checking.....	95
Proper Solution.....	136
Replacing.....	138
Temperature Gauge.....	38
Corrosion Protection.....	177
Crankcase Emission Control System.....	209
Cruise Control Operation.....	46
Customer Relations Office.....	215

## D

DANGER, Explanation of.....	ii
Dashboard.....	32
Daytime Running Lights.....	41
Dead Battery, What to Do.....	187
Defects, Reporting Safety.....	218

Defog and Defrost.....	73
Defogger, Rear Window.....	44
Defrosting the Windows.....	73
DEXRON® III Automatic Transmission Fluid.....	142
Dimensions.....	204
Dimming the Headlights.....	41
Dipstick	
Automatic Transmission.....	142
Engine Oil.....	94
Directional Signals.....	42
Disabled, Towing Your Car If.....	200
Disc Brake Wear Indicators.....	114
Disposal of Used Oil.....	135
Doors	
Locking and Unlocking.....	50
Power Door Locks.....	51
DOT Tire Quality Grading.....	207
Downshifting, 5-speed Manual Transmission.....	102
Drive Belts.....	155
Driving.....	99
Economy.....	96
In Bad Weather.....	118
In Foreign Countries.....	91

## E

Economy, Fuel.....	96
Emergencies on the Road.....	179
Battery, Jump Starting.....	187
Changing a Flat Tire.....	181
Charging System Indicator.....	192
Checking the Fuses.....	196
Low Oil Pressure Indicator.....	191
Malfunction Indicator Lamp... ..	193
Manually Closing Moonroof... ..	194
Overheated Engine.....	189
Emergency Brake.....	62
Emergency Flashers.....	44
Emission Controls.....	209
Engine	
Coolant Temperature Gauge .....	38
Malfunction Indicator Lamp.....	35, 193
Oil Pressure Indicator.....	35, 191
Oil, What Kind to Use.....	132
Overheating.....	189
Specifications.....	204
Ethanol in Gasoline .....	91

CONTINUED

# Index

Evaporative Emission Controls....	209
Exhaust Fumes.....	28
Expectant Mothers, Use of Seat Belts by.....	10
Exterior, Cleaning the.....	174

## F

Fabric, Cleaning.....	176
Fan, Interior.....	68
Features, Comfort and Convenience.....	67
Filling the Fuel Tank.....	92
Filters	
Air.....	146
Oil.....	134
5-speed Manual Transmission	
Checking Fluid Level.....	143
Shifting the.....	102
Flashers, Hazard Warning.....	44
Flat Tire, Changing a.....	180
Fluids	
Automatic Transmission.....	141
Brake.....	144
Clutch.....	144
Manual Transmission.....	143

Power Steering.....	145
Windshield Washer.....	141
FM Stereo Radio	
Reception.....	76
Folding Rear Seat.....	58
Foreign Countries, Driving in.....	91
Four-way Flashers.....	44
Front End, Towing by	
Emergency Wrecker.....	200
Fuel.....	90
Fill Door and Cap.....	92
Gauge.....	38
Octane Requirement.....	90
Oxygenated.....	90
Reserve Indicator.....	36
Tank, Filling the.....	92
Fuses, Checking the.....	196

## G

Gas Mileage, Improving.....	96
Gasohol.....	91
Gasoline.....	90
Fuel Reserve Indicator.....	36
Gauge.....	38
Octane Requirement.....	90

Tank, Filling the.....	92
Gas Station Procedures.....	92
Gauges	
Engine Coolant Temperature ....	38
Fuel.....	38
Gearshift Lever Positions	
Automatic Transmission.....	105
CVT.....	109
5-speed Manual Transmission.....	102
Glass Cleaning.....	177
Glove Box.....	63

## H

Halogen Headlight Bulbs.....	164
Hazard Warning Flashers.....	44
Headlights	
Aiming.....	162
Daytime Running Lights.....	41
High Beam Indicator.....	35
High Beams, Turning on.....	41
Low Beams, Turning on .....	41
Reminder Beeper.....	41
Replacing Halogen Bulbs .....	164
Turning on.....	41

Head Restraints.....	57
Heating and Cooling.....	68
High Altitude, Starting at.....	101
High-Low Beam Switch .....	41
High-mount Brake Light.....	169
Hood, Opening the .....	93
Horn.....	40
Hot Coolant, Warning about.....	136
Hydraulic Clutch.....	144
Hydroplaning.....	119

**I**

Identification Number, Vehicle....	202
If Your Car Has to be Towed.....	200
Ignition	
Keys.....	49
Switch.....	49
Timing Control System.....	210
Indicator Lights, Instrument	
Panel.....	33
Infant Restraint.....	22
Inflation, Proper Tire .....	156
Normal Driving.....	157
High Speed Driving.....	207
Inside Mirror.....	61

Inspection, Tire.....	158
Instrument Panel.....	32
Instrument Panel Brightness.....	42
Interior Cleaning.....	176
Interior Light.....	66
Introduction.....	i

**J**

Jacking up the Car.....	182
Jack, Tire.....	181
Jump Starting.....	187

**K**

Keys.....	49
-----------	----

**L**

Label, Certification.....	202
Lane Change, Signaling.....	42
Lap Belt.....	7
Lap/Shoulder Belts.....	6
Leaking of Exhaust into Car.....	28
Lights	
Bulb Replacement.....	164

Indicator.....	33
Parking.....	41
Turn Signal.....	42
Loading Cargo.....	98
LOCK (Ignition Key Position).....	50
Locks	
Anti-theft Steering Column.....	50
Fuel Fill Door.....	92
Power Door.....	51
Trunk.....	55
Low Coolant Level.....	136
Low Fuel Indicator.....	36
Lower Gear, Downshifting to a....	102
Low Oil Pressure Indicator....	35, 191
Lubricant Specifications Chart....	204
Luggage.....	98

**M**

Maintenance.....	121
Owner Maintenance Checks....	130
Periodic Items.....	130
Record.....	128-129
Required Indicator.....	39

CONTINUED

# Index

Maintenance	
Safety.....	122
Schedule.....	126-127
Malfunction Indicator Lamp .	35, 193
Manual Transmission.....	102
Manual Transmission Fluid .....	143
Maximum Shift Speeds.....	103, 107
Meters, Gauges.....	37
Methanol in Gasoline.....	91
Mirrors, Adjusting.....	61
Moonroof.....	61
Closing Manually.....	194
Operation.....	61

## N

Neutral Gear Position.....	106
New Vehicle Break-in .....	90
Normal Shift Speeds.....	102
NOTICE, Explanation of.....	ii
Numbers, Identification.....	202

## O

Occupant Protection System.....	4
Octane Requirement, Gasoline.....	90

Odometer.....	37
Odometer, Trip.....	37
Oil	
Change, How to.....	134
Change, When to.....	126
Checking Engine.....	94
Pressure Indicator.....	35, 191
Selecting Proper Viscosity Chart.....	133
ON (Ignition Key Position).....	50
Opening the Hood .....	93
Opening the Trunk.....	55
Operation in Foreign Countries.....	91
Outside Mirrors.....	61
Overheating, Engine.....	189
Owner Maintenance Checks.....	130

## P

Panel Brightness Control.....	42
Park Gear Position.....	105
Parking.....	113
Parking Brake.....	62
Parking Eights.....	41
Parking Over Things that Burn...	211
PGM-FI System.....	210

Polishing and Waxing.....	174
Power	
Door Locks.....	51
Mirrors.....	62
Steering.....	145
Windows.....	59
Pregnancy, Using Seat Belts.....	10
Proper Seat Belt Usage.....	7

## R

Radiator Overheating.....	189
Radio/Cassette Sound System.....	76
Rear End Towing.....	200
Rear Lights, Bulb Replacement...	167
Rear Seat, Folding.....	58
Rear View Mirror.....	61
Rear Window Defogger.....	44
Reclining the Seat Backs.....	56
Recommended Shift Speeds .....	102
Reminder Lights.....	33
Remote Transmitter.....	52
Replacement Information	
Air Cleaner Element.....	146
Coolant.....	138
Engine Oil and Filter.....	134

Replacement Information			
Fuses.....	196		
Light Bulbs.....	164		
Schedule.....	126		
Spark Plugs.....	148		
Timing Belt.....	155		
Tires.....	159		
Wiper Blades.....	152		
Replacing Seat Belts After a			
Crash.....	11		
Reserve Tank, Engine			
Coolant.....	95, 136		
Restraint, Child.....	20		
Reverse Gear Position.....	106		
Rotation, Tire.....	159		
<b>S</b>			
Safety Belts.....	5		
Safety Defects, Reporting* .....	218		
Safety Labels, Location of.....	29		
Safety Messages.....	ii		
Seat Belts.....	5		
Advice for Pregnant Women.....	10		
Child Seat Anchor Plate.....	25		
Cleaning.....	176		
Frayed or Torn.....	11		
Maintenance.....	11		
Reminder Light and Beeper.....	34		
Replacement.....	11		
System Components.....	6		
Tether Attachment Points.....	25		
Use During Pregnancy.....	10		
Wearing a Lap/Shoulder Belt.....	7		
Wearing the Lap Belt.....	9		
Seats, Adjusting the.....	56		
Serial Number.....	202		
Service Intervals.....	126		
Service Manual* .....	219		
Service Station Procedures .....	92		
Setting the Clock.....	81		
Shifting			
The Automatic Transmission ..	103		
The CVT.....	109		
The 5-speed Manual			
Transmission.....	102		
Shift Lever Position Indicator.....	109		
Shift Lock Release.....	108		
Side Marker Lights, Bulb			
Replacement in.....	166		
Signaling Turns.....	42		
Snow Tires.....	161		
Solvent-type Cleaners.....	174		
Sound System.....	76		
Spare Tire			
Inflating.....	180		
Specifications.....	205		
Spark Plugs, Replacing.....	148		
Specifications Charts.....	204		
Speed Control.....	46		
Speedometer.....	37		
SRS Indicator.....	16, 34		
START (Ignition Key Position) .....	50		
Starting the Engine.....	101		
In Cold Weather at High			
Altitude.....	101		
With a Dead Battery .....	187		
Steam Coming from Engine.....	189		
Steering Wheel			
Adjustment.....	45		
Anti-theft Column Lock.....	50		
Stereo Sound System .....	76		
Storing Your Car.....	172		

CONTINUED

Supplemental Restraint System	
Important Facts.....	13
Service Precautions.....	17
Servicing.....	16
SRS Indicator.....	16, 34
System Components.....	12
What Happens In a Crash.....	12
Synthetic Oil.....	133

## T

Tachometer.....	37
Taillights, Changing Bulbs in.....	167
Taking Care of the Unexpected ..	179
Tape Player.....	82
Technical Descriptions	
Emission Control Systems.....	209
Three Way Catalytic Converter.....	211
Tire Information.....	206
Temperature Gauge.....	38
Tether Attachment Points.....	25
Three Way Catalytic Converter...	211
Time, Setting the.....	81
Timing Belt.....	155
Tire Chains.....	161

Tire, How to Change a Flat.....	181
Tires.....	156
Air Pressure.....	156
Checking Wear.....	158
Compact Spare.....	180
DOT Tire Quality Grading.....	207
Inflation.....	156
Inspection.....	158
Maintenance.....	158
Replacing.....	159
Rotating.....	159
Snow.....	161
Specifications.....	205
Technical Information.....	206
Technical Information.....	201
Tools, Tire Changing.....	181
Torn Seat Belts.....	11
Towing	
A Trailer.....	119
By Emergency Wrecker.....	200
Transmission	
Checking Fluid Level, Automatic.....	141
Checking Fluid Level, Manual.....	143
Fluid Selection.....	142

Identification Number.....	203
Shifting the Automatic.....	104
Shifting the CVT.....	109
Shifting the Manual.....	102
Treadwear.....	207
Trip Meter.....	37
Trunk.....	55
Opening.....	55
Open Monitor Light.....	36
Turn Signals.....	42

## U

Underside, Cleaning.....	177
Unexpected, Taking Care of the.....	179
Uniform Tire Quality Grading.....	207
Unleaded Gasoline.....	90
Upholstery Cleaning.....	176
Used Oil, How to Dispose of.....	135

## V

Vehicle Capacity Load .....	98
Vehicle Dimensions.....	204
Vehicle Identification Number.....	202

Vehicle Storage.....	172
Ventilation.....	71
VIN.....	202
Vinyl Cleaning.....	176
Viscosity, Oil.....	133

<b>W</b>
----------

Warning Bleepers	
Headlights on.....	41
Key in Ignition.....	50
Seat Belts.....	34
WARNING, Explanation of.....	ii
Warning Labels, Location of.....	29
Warranty Coverages*.....	217
Washer, Windshield	
Checking the Fluid Level.....	141
Operation.....	43
Washing.....	174
Waxing and Polishing.....	174
Wheels	
Adjusting the Steering.....	45
Alignment and Balance.....	158
Compact Spare.....	180
Wrench.....	182

Windows	
Cleaning.....	177
Operating the Power.....	59
Rear, Defogger.....	44
Windshield	
Cleaning.....	43
Defroster.....	73
Wipers, Windshield	
Changing Blades.....	152
Operation.....	43
Worn Tires.....	158
Wrecker, Emergency Towing.....	200

\* : U.S. and Canada only

## Gas Station Information

---

### Gasoline:

UNLEADED gasoline  
Pump octane number of 86 or higher

### Fuel Tank Capacity:

45 l (11.9 US gal, 9.9 Imp gal)

### Recommended Engine Oil:

API SJ or SH grade  
"Energy Conserving" or  
"Energy Conserving II" oil  
SAE 5W-30 viscosity

### Tire Pressure (measured cold):

Front:

210 kPa (2.1 kgf/cm<sup>2</sup>, 30 psi)

Rear:

200 kPa (2.0 kgf/cm<sup>2</sup>, 29 psi)

### Spare Tire Pressure:

420 kPa (4.2 kgf/cm<sup>2</sup>, 60 psi)

### Automatic Transmission Fluid:

Honda Premium Formula Automatic Transmission Fluid (ATF)

*HX model (CVT) only:*

Use Honda CVT Fluid only