

2007 Civic Hybrid Online Reference Owner's Manual

Use these links (and links throughout this manual) to navigate through this reference.
For a printed owner's manual, click on authorized manuals or go to www.helminc.com.

Contents

Owner's Identification Form

Introduction	i
A Few Words About Safety	iii
Your Vehicle at a Glance	3
Driver and Passenger Safety	5
Proper use and care of your vehicle's seat belts, and Supplemental Restraint System.	
Instruments and Controls	55
Instrument panel indicator and gauge, and how to use dashboard and steering column controls.	
Comfort and Convenience Features	99
How to operate the climate control system, the audio system, and other convenience features.	
Before Driving	149
What gasoline to use, how to break-in your new vehicle, and how to load luggage and other cargo.	
Driving	163
The proper way to start the engine, shift the transmission, and park, plus towing a trailer.	
Maintenance	177
The Maintenance Schedule shows you when you need to take your vehicle to the dealer.	
Taking Care of the Unexpected	215
This section covers several problems motorists sometimes experience, and how to handle them.	
Technical Information	239
ID numbers, dimensions, capacities, and technical information.	
Warranty and Customer Relations (U.S. and Canada)	251
A summary of the warranties covering your new Acura, and how to contact us.	
Authorized Manuals (U.S. only)	255
How to order manuals and other technical literature.	
Index	I

Service Information Summary

A summary of information you need when you pull up to the fuel pump.

Navigation System

Congratulations! Your selection of a 2007 Honda Civic Hybrid was a wise investment. It will give you years of driving pleasure.

One of the best ways to enhance the enjoyment of your new vehicle is to read this manual. In it, you will learn how to operate its driving controls and convenience items. Afterwards, keep this owner's manual in your vehicle so you can refer to it at any time.

Several warranties protect your new vehicle. Read the warranty booklet thoroughly so you understand the coverages and are aware of your rights and responsibilities.

Maintaining your vehicle according to the schedules given in this manual helps to keep your driving trouble-free while it preserves your investment. When your vehicle needs maintenance, keep in mind that your dealer's staff is specially trained in servicing the many systems unique to your vehicle. Your dealer is dedicated to your satisfaction and will be pleased to answer any questions and concerns.

As you read this manual, you will find information that is preceded by a **NOTICE** symbol. This information is intended to help you avoid damage to your vehicle, other property, or the environment.

Introduction

California Proposition 65 Warning

WARNING: This product contains or emits chemicals known to the state of California to cause cancer and birth defects or other reproductive harm.

Event Data Recorders

This vehicle is equipped with one or more devices commonly referred to as event data recorders. These devices record front seat belt use, front passenger seat occupancy, airbag deployment data, and the failure of any airbag system component. This data belongs to the vehicle owner and may not be accessed by anyone else except as legally required or with the permission of the vehicle owner.

Service Diagnostic Recorders

This vehicle is equipped with service-related devices that record information about powertrain performance. The data can be used to verify emissions law requirements and/or help technicians diagnose and solve service problems. It may also be combined with data from other sources for research purposes, but it remains confidential and is never linked to the vehicle owner.

Your safety, and the safety of others, is very important. And operating this vehicle safely is an important responsibility.

To help you make informed decisions about safety, we have provided operating procedures and other information on labels and in this manual. This information alerts you to potential hazards that could hurt you or others.

Of course, it is not practical or possible to warn you about all the hazards associated with operating or maintaining your vehicle. You must use your own good judgement.

You will find this important safety information in a variety of forms, including:

- **Safety Labels** – on the vehicle.
- **Safety Messages** – preceded by a safety alert symbol  and one of three signal words: **DANGER**, **WARNING**, or **CAUTION**.
These signal words mean:

 **DANGER**

You **WILL** be **KILLED** or **SERIOUSLY HURT** if you don't follow instructions.

 **WARNING**

You **CAN** be **KILLED** or **SERIOUSLY HURT** if you don't follow instructions.

 **CAUTION**

You **CAN** be **HURT** if you don't follow instructions.

- **Safety Headings** – such as Important Safety Reminders or Important Safety Precautions.
- **Safety Section** – such as Driver and Passenger Safety.
- **Instructions** – how to use this vehicle correctly and safely.

This entire book is filled with important safety information – please read it carefully.

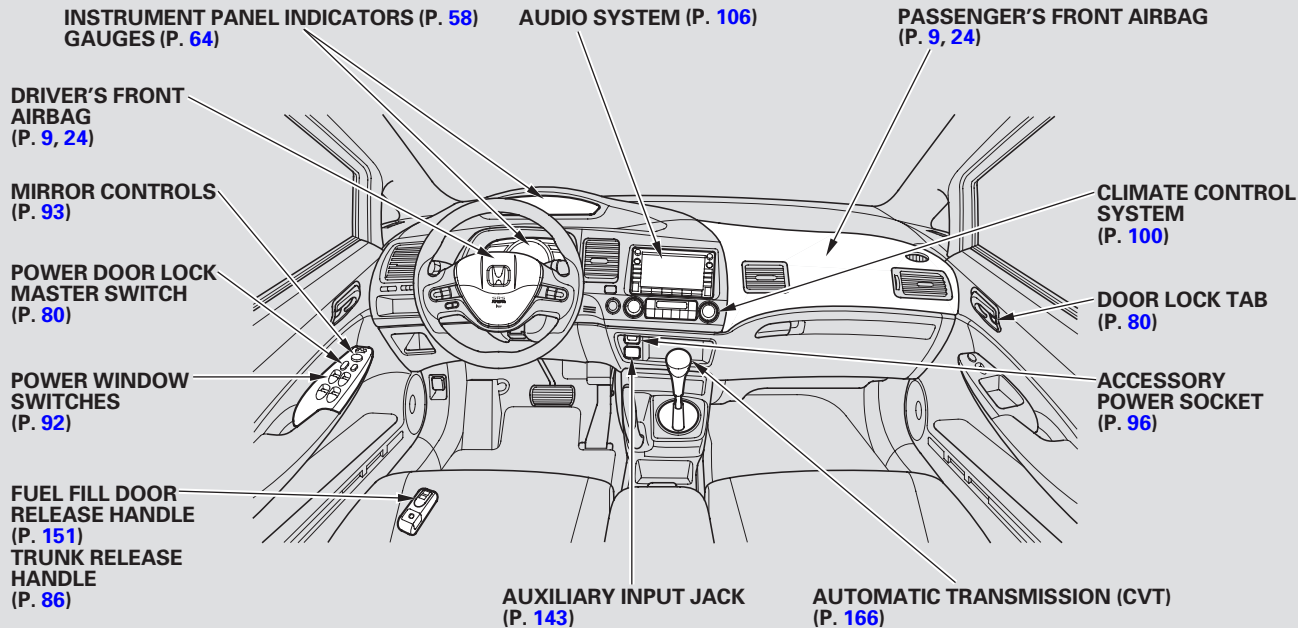

Vehicle with navigation system is shown

Your Vehicle at a Glance

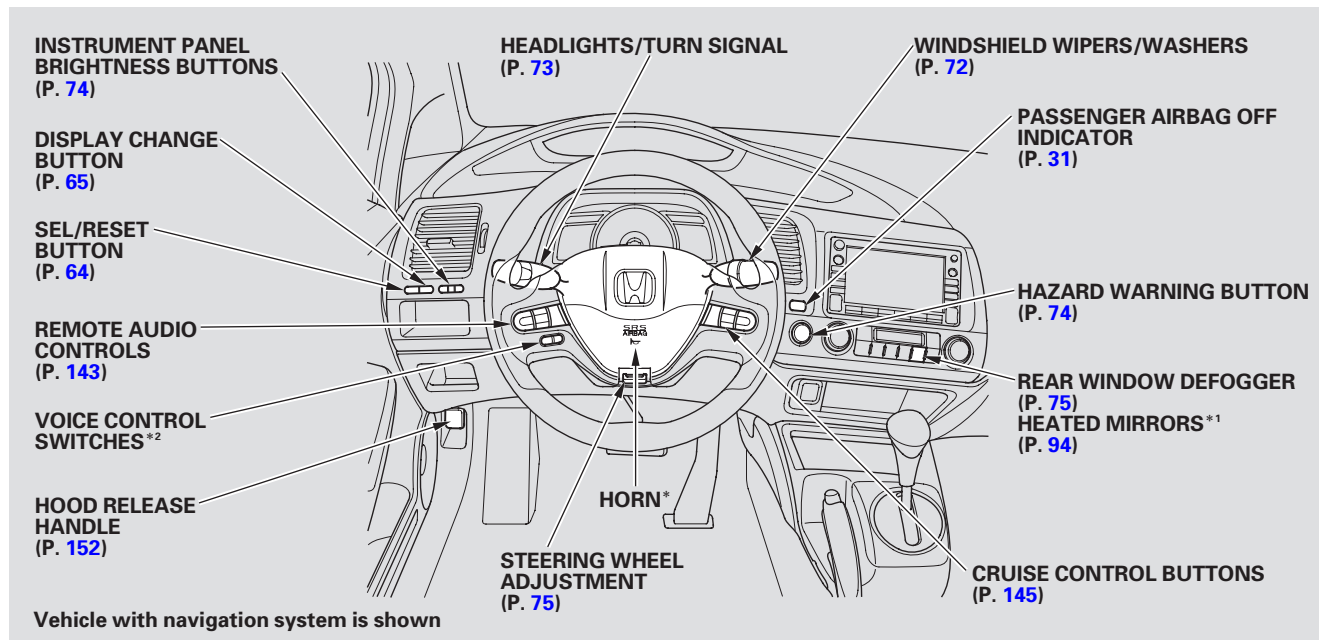

* : To use the horn, press the pad around the “H” logo.

* 1 : Canadian model only

* 2 : Only on vehicles equipped with navigation system. Refer to the navigation system manual.

This section gives you important information about how to protect yourself and your passengers. It shows you how to use seat belts. It explains how your airbags work. And it tells you how to properly restrain infants and children in your vehicle.

Important Safety Precautions	6
Your Vehicle's Safety Features.....	7
Seat Belts	8
Airbags.....	9
Protecting Adults and Teens.....	11
1. Close and Lock the Doors.....	11
2. Adjust the Front Seats	11
3. Adjust the Seat-Backs	12
4. Adjust the Head Restraints	13
5. Fasten and Position the Seat Belts.....	14
6. Maintain a Proper Sitting Position	15
Advice for Pregnant Women.....	16
Additional Safety Precautions....	17

Additional Information About Your Seat Belts	18
Seat Belt System Components...	18
Lap/Shoulder Belt.....	19
Automatic Seat Belt Tensioners.....	19
Seat Belt Maintenance	20
Additional Information About Your Airbags	21
Airbag System Components.....	21
How Your Front Airbags Work.....	24
How Your Side Airbags Work....	28
How Your Side Curtain Airbags Work.....	29
How the SRS Indicator Works...	30
How the Side Airbag Off Indicator Works.....	30
How the Passenger Airbag Off Indicator Works.....	31
Airbag Service.....	32
Additional Safety Precautions....	32
Protecting Children – General Guidelines.....	34
All Children Must Be Restrained	34

All Children Should Sit in a Back Seat	35
The Passenger's Front Airbag can Pose Serious Risks	35
If You Must Drive with Several Children	37
If a Child Requires Close Attention	37
Additional Safety Precautions....	38
Protecting Infants and Small Children	39
Protecting Infants.....	39
Protecting Small Children	40
Selecting a Child Seat.....	41
Installing a Child Seat	42
With LATCH	43
With a Lap/shoulder Belt.....	45
With a Tether	47
Protecting Larger Children	48
Checking Seat Belt Fit	48
Using a Booster Seat.....	49
When Can a Larger Child Sit in Front.....	50
Additional Safety Precautions....	51
Carbon Monoxide Hazard	52
Safety Labels	53

Important Safety Precautions

You'll find many safety recommendations throughout this section, and throughout this manual. The recommendations on this page are the ones we consider to be the most important.

Always Wear Your Seat Belt

A seat belt is your best protection in all types of collisions. Airbags are designed to supplement seat belts, not replace them. So even though your vehicle is equipped with airbags, make sure you and your passengers always wear your seat belts, and wear them properly (see page 14).

Restrain All Children

Children age 12 and under should ride properly restrained in a back seat, not the front seat. Infants and small children should be restrained in a child seat. Larger children should use a booster seat and a lap/shoulder belt until they can use the belt properly without a booster seat (see pages 34 – 51).

Be Aware of Airbag Hazards

While airbags can save lives, they can cause serious or fatal injuries to occupants who sit too close to them, or are not properly restrained. Infants, young children, and short adults are at the greatest risk. Be sure to follow all instructions and warnings in this manual.

Don't Drink and Drive

Alcohol and driving don't mix. Even one drink can reduce your ability to respond to changing conditions, and your reaction time gets worse with

every additional drink. So don't drink and drive, and don't let your friends drink and drive, either.

Control Your Speed

Excessive speed is a major factor in crash injuries and deaths. Generally, the higher the speed, the greater the risk, but serious injuries can also occur at lower speeds. Never drive faster than is safe for current conditions, regardless of the maximum speed posted.

Keep Your Vehicle in Safe Condition

Having a tire blowout or a mechanical failure can be extremely hazardous. To reduce the possibility of such problems, check your tire pressures and condition frequently, and perform all regularly scheduled maintenance (see page 179).

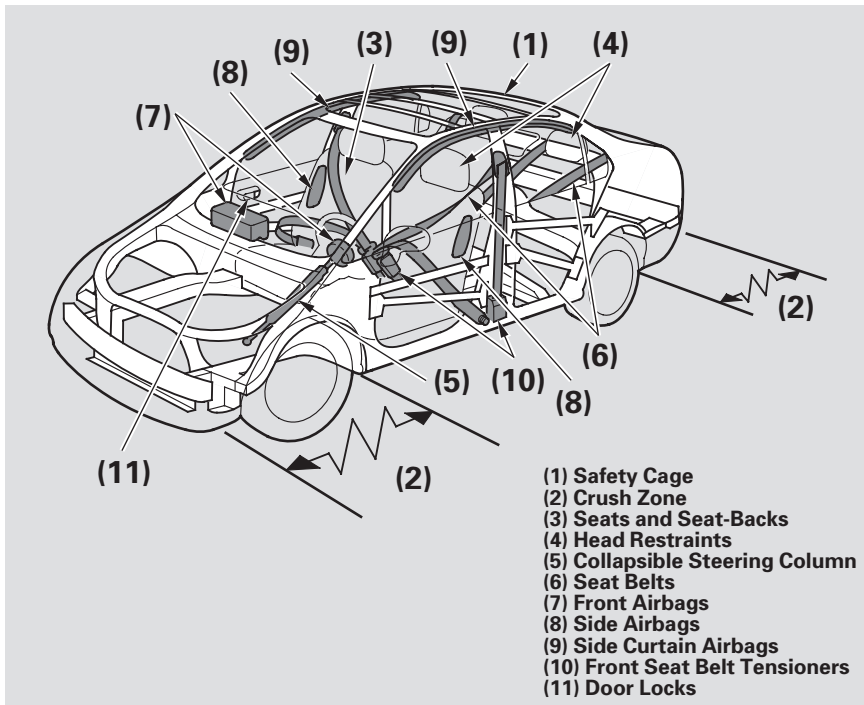

Your vehicle is equipped with many features that work together to protect you and your passengers during a crash.

Some features do not require any action on your part. These include a strong steel framework that forms a safety cage around the passenger compartment, front and rear crush zones, a collapsible steering column, and tensioners that tighten the front seat belts in a crash.

However, you and your passengers can't take full advantage of these features unless you remain sitting in a proper position and ***always wear your seat belts***. In fact, some safety features can contribute to injuries if they are not used properly.

The following pages explain how you can take an active role in protecting yourself and your passengers.

Your Vehicle's Safety Features

Seat Belts

Your vehicle is equipped with seat belts in all seating positions.

Your seat belt system also includes an indicator on the instrument panel and a beeper to remind you and your passengers to fasten your seat belts.

Why Wear Seat Belts

Seat belts are the single most effective safety device for adults and larger children. (Infants and smaller children must be properly restrained in child seats.)

Not wearing a seat belt properly increases the chance of serious injury or death in a crash, even though your vehicle has airbags.

In addition, most states and all Canadian provinces require you to wear seat belts.

▲ WARNING

Not wearing a seat belt properly increases the chance of serious injury or death in a crash, even though your vehicle has airbags.

Be sure you and your passengers always wear seat belts and wear them properly.

When properly worn, seat belts:

- Keep you connected to the vehicle so you can take advantage of the vehicle's built-in safety features.
- Help protect you in almost every type of crash, including frontal, side and rear impacts, and rollovers.

- Help keep you from being thrown against the inside of the vehicle and against other occupants.
- Keep you from being thrown out of the vehicle.
- Help keep you in a good position should the airbags ever deploy. A good position reduces the risk of injury from an inflating airbag and allows you to get the best advantage from the airbag.

Of course, seat belts cannot completely protect you in every crash. But in most cases, seat belts can reduce your risk of serious injury.

What You Should Do:

Always wear your seat belt, and make sure you wear it properly.

Airbags

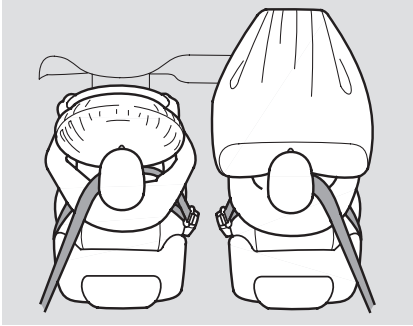

Your vehicle has a supplemental restraint system (SRS) with front airbags to help protect the heads and chests of the driver and a front seat passenger during a moderate to severe frontal collision (see page [24](#) for more information on how your front airbags work).

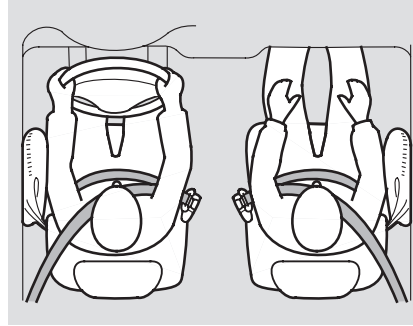

Your vehicle also has side airbags to help protect the upper torso of the driver or a front seat passenger during a moderate to severe side impact (see page [28](#) for more information on how your side airbags work).

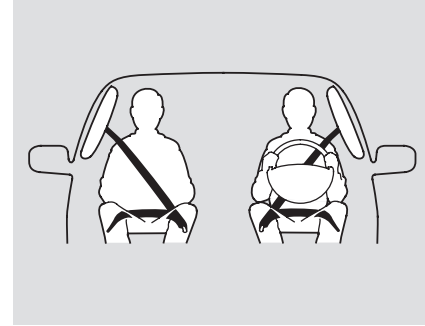

In addition, your vehicle has side curtain airbags to help protect the heads of the driver, front passenger, and passengers in the outer rear seating positions during a moderate to severe side impact (see page [29](#) for more information on how your side curtain airbags work).

CONTINUED

Your Vehicle's Safety Features

The most important things you need to know about your airbags are:

- ***Airbags do not replace seat belts.*** They are designed to supplement the seat belts.
- ***Airbags offer no protection in rear impacts, or minor frontal or side collisions.***
- ***Airbags can pose hazards.*** To do their job, airbags must inflate with tremendous force. So while airbags help save lives, they can cause minor injuries or more serious or even fatal injuries if occupants are not properly restrained or sitting properly.

What you should do: Always wear your seat belt properly, and sit upright and as far back from the steering wheel as possible while allowing full control of the vehicle. A front passenger should move their seat as far back from the dashboard as possible.

The rest of this section gives more detailed information about how you can maximize your safety.

Remember however, that no safety system can prevent all injuries or deaths that can occur in a severe crash, even when seat belts are properly worn and the airbags deploy.

Introduction

The following pages provide instructions on how to properly protect the driver, adult passengers and teenage children who are large enough and mature enough to drive or ride in the front seat.

See pages [34](#) – [51](#) for important guidelines on how to properly protect infants, small children, and larger children who ride in your vehicle.

1. Close and Lock the Doors

After everyone has entered the vehicle, be sure the doors are closed and locked.



Your vehicle has a door-open indicator on the instrument panel to indicate when any door is not tightly closed.

Locking the doors reduces the chance of someone being thrown out of the vehicle during a crash, and it helps prevent passengers from accidentally opening a door and falling out.

Locking the doors also helps prevent an outsider from unexpectedly opening a door when you come to a stop.

See page [80](#) for how to lock the doors, page [60](#) for how the door-open indicator works, and page [81](#) for how the automatic door locking and unlocking feature works.

2. Adjust the Front Seats

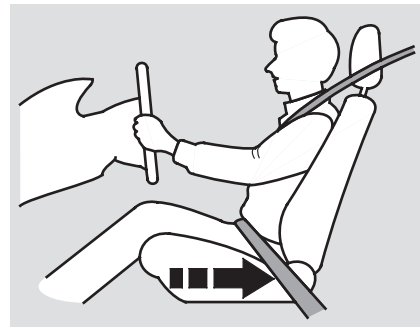

Adjust the driver's seat as far to the rear as possible while allowing you to maintain full control of the vehicle. Have a front passenger adjust their seat as far to the rear as possible.

CONTINUED

Protecting Adults and Teens

If you sit too close to the steering wheel or dashboard, you can be seriously injured by an inflating front airbag, or by striking the steering wheel or dashboard.

The National Highway Traffic Safety Administration and Transport Canada recommend that drivers allow at least 10 inches (25 cm) between the center of the steering wheel and the chest. In addition to adjusting the seat, you can adjust the steering wheel up and down, and in and out (see page 75).

If you cannot get far enough away from the steering wheel and still reach the controls, we recommend that you investigate whether some type of adaptive equipment may help.

⚠ WARNING

Sitting too close to a front airbag can result in serious injury or death if the front airbags inflate.

Always sit as far back from the front airbags as possible.

Once a seat is adjusted correctly, rock it back and forth to make sure it is locked in position.

See page 89 for how to adjust the front seats.

3. Adjust the Seat-Backs

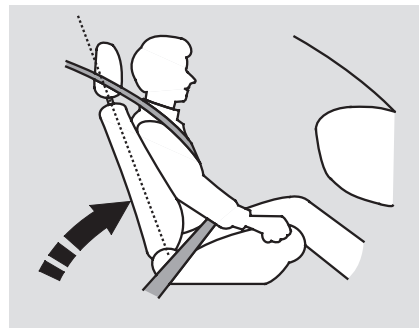

Adjust the driver's seat-back to a comfortable, upright position, leaving ample space between your chest and the airbag cover in the center of the steering wheel.

Passengers with adjustable seat-backs should also adjust their seat-back to a comfortable, upright position.

⚠ WARNING

Reclining the seat-back too far can result in serious injury or death in a crash.

Adjust the seat-back to an upright position, and sit well back in the seat.

Reclining a seat-back so that the shoulder part of the belt no longer rests against the occupant's chest reduces the protective capability of the belt. It also increases the chance of sliding under the belt in a crash and being seriously injured. The farther a seat-back is reclined, the greater the risk of injury.

See page [90](#) for how to adjust the seat-backs.

4. Adjust the Head Restraints

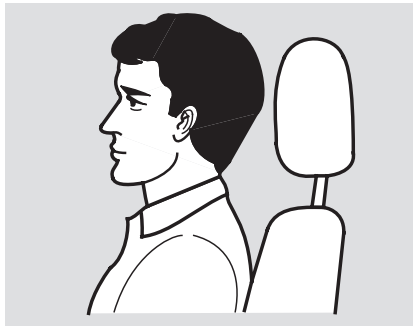

Adjust the driver's head restraint so the back of your head rests against the center of the restraint.

Have passengers adjust their head restraints properly as well. Taller persons should adjust their restraint as high as possible.

When a passenger is seated in the rear center seating position, make sure the center head restraint is adjusted to its highest position.

⚠ WARNING

Improperly positioning head restraints reduces their effectiveness, and you can be seriously injured in a crash.

Make sure head restraints are in place and positioned properly before driving.

Properly adjusted head restraints will help protect occupants from whiplash and other crash injuries.

See page [91](#) for how to adjust the head restraints.

Protecting Adults and Teens

5. Fasten and Position the Seat Belts

Insert the latch plate into the buckle, then tug on the belt to make sure the belt is securely latched. Check that the belt is not twisted, because a twisted belt can cause serious injuries in a crash.



Position the lap part of the belt as low as possible across your hips, then pull up on the shoulder part of the belt so the lap part fits snugly. This lets your strong pelvic bones take the force of a crash and reduces the chance of internal injuries.

⚠ WARNING

Improperly positioning the seat belts can cause serious injury or death in a crash.

Make sure all seat belts are properly positioned before driving.

If the seat belt touches or crosses your neck, or if it crosses your arm instead of your shoulder, you need to adjust the seat belt anchor height.

If necessary, pull up on the belt again to remove any slack, then check that the belt rests across the center of your chest and over your shoulder. This spreads the forces of a crash over the strongest bones in your upper body.

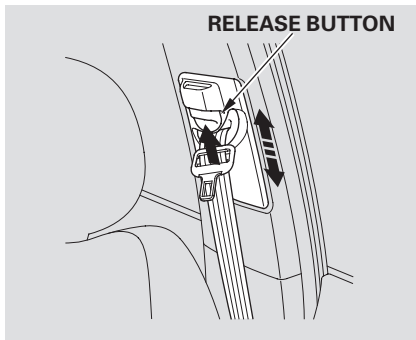

The front seats have adjustable seat belt anchors. To adjust the height of an anchor, press and hold the release button and slide the anchor up or down as needed (it has four positions).

Never place the shoulder portion of a lap/shoulder belt under your arm or behind your back. This could cause very serious injuries in a crash.

If a seat belt does not seem to work properly, it may not protect the occupant in a crash.

No one should sit in a seat with an inoperative seat belt. Using a seat belt that is not working properly can result in serious injury or death. Have your dealer check the belt as soon as possible.

See page 18 for additional information about your seat belts and how to take care of them.

6. Maintain a Proper Sitting Position

After all occupants have adjusted their seats and put on seat belts, it is very important that they continue to sit upright, well back in their seats, with their feet on the floor, until the vehicle is parked and the engine is off.

Sitting improperly can increase the chance of injury during a crash. For example, if an occupant slouches, lies down, turns sideways, sits forward, leans forward or sideways, or puts one or both feet up, the chance of injury during a crash is greatly increased.

CONTINUED

Protecting Adults and Teens

In addition, an occupant who is out of position in the front seat can be seriously or fatally injured in a crash by striking interior parts of the vehicle or being struck by an inflating front airbag.

⚠ WARNING

Sitting improperly or out of position can result in serious injury or death in a crash.

Always sit upright, well back in the seat, with your feet on the floor.

Advice for Pregnant Women



If you are pregnant, the best way to protect yourself and your unborn child when driving or riding in a vehicle is to always wear a seat belt, and keep the lap part of the belt as low as possible across the hips.

When driving, remember to sit upright and adjust the seat as far back as possible while allowing full control of the vehicle. When riding as a front passenger, adjust the seat as far back as possible.

This will reduce the risk of injuries to both you and your unborn child that can be caused by a crash or an inflating front airbag.

Each time you have a checkup, ask your doctor if it's okay for you to drive.

Additional Safety Precautions

- **Two people should never use the same seat belt.** If they do, they could be very seriously injured in a crash.
- **Do not put any accessories on seat belts.** Devices intended to improve occupant comfort or reposition the shoulder part of a seat belt can reduce the protective capability of the seat belt and increase the chance of serious injury in a crash.
- **Do not place hard or sharp objects between yourself and a front airbag.** Carrying hard or sharp objects on your lap, or driving with a pipe or other sharp object in your mouth, can result in injuries if your front airbag inflates.
- **Do not attach or place objects on the front airbag covers.** Objects on the covers marked “SRS AIRBAG” could interfere with the proper operation of the airbags or be propelled inside the vehicle and hurt someone if the airbags inflate.
- **Keep your hands and arms away from the airbag covers.** If your hands or arms are close to an airbag cover, they could be injured if the airbag inflates.
- **Do not attach hard objects on or near a door.** If a side airbag or a side curtain airbag inflates, a cup holder or other hard object attached on or near the door could be propelled inside the vehicle and hurt someone.

Additional Information About Your Seat Belts

Seat Belt System Components

Your seat belt system includes lap/shoulder belts in all seating positions. The front seat belts are also equipped with automatic seat belt tensioners.

This system uses the same sensors as the front airbags to monitor whether the front seat belts are latched or unlatched, and how much weight is on the front passenger's seat (see pages 26 and 27).

Seat Belt Indicator



The seat belt system includes an indicator on the instrument panel and a beeper to remind you and your passengers to fasten your seat belts.

This system monitors the front seat belts. If you turn the ignition switch to the ON (II) position before your seat belt is fastened, the beeper will sound and the indicator will flash. If your seat belt is not fastened before the beeper stops, the indicator will stop flashing but remain on.

If a front passenger does not fasten their seat belt, the indicator will come on about 6 seconds after the ignition switch is turned to the ON (II) position.

If either the driver or a front passenger does not fasten their seat belt while driving, the beeper will sound and the indicator will flash again at regular intervals.

When no one is sitting in the front passenger's seat, or a child or small adult is riding there, the indicator should not come on and the beeper should not sound.

If the indicator comes on or the beeper sounds when the driver's seat belt is latched and there is no front seat passenger and no items on the front seat, something may be interfering with the monitoring system. Look for and remove:

- Any items under the front passenger's seat.
- Any objects hanging on the seat or in the seat-back pocket.
- Any object on the floor that is touching the rear of the seat-back.

If no obstructions are found, have your vehicle checked by a dealer.

Lap/Shoulder Belt

The lap/shoulder belt goes over your shoulder, across your chest, and across your hips.

To fasten the belt, insert the latch plate into the buckle, then tug on the belt to make sure the buckle is latched (see page 14 for how to properly position the belt).

To unlock the belt, press the red PRESS button on the buckle. Guide the belt across your body so that it retracts completely. After exiting the vehicle, be sure the belt is out of the way and will not get closed in the door.

All seat belts have an emergency locking retractor. In normal driving, the retractor lets you move freely in your seat while it keeps some tension on the belt. During a collision or sudden stop, the retractor automatically locks the belt to help

restrain your body.

The seat belts in all positions except the driver's have an additional lockable retractor that must be activated to secure a child seat (see page 45).

If the shoulder part of the belt is pulled all the way out, the lockable retractor will activate. The belt will retract, but it will not allow the passenger to move freely.

To deactivate the lockable retractor, unlatch the buckle and let the seat belt fully retract. To refasten the seat belt, pull it out only as far as needed.

Automatic Seat Belt Tensioners

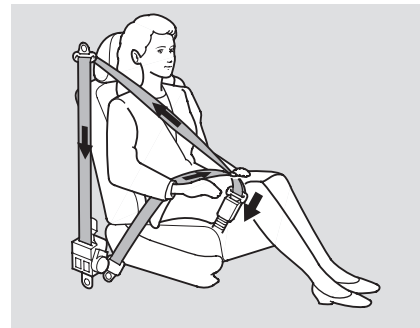

For added protection, the front seat belts are equipped with automatic seat belt tensioners. When activated, the tensioners immediately tighten the belts to help hold the driver and a front passenger in position.

The tensioners are designed to activate in any collision severe enough to cause a front, side, or side curtain airbag to inflate.

CONTINUED

Additional Information About Your Seat Belts

If a side airbag or side curtain airbag deploys during a side impact, the tensioner on that side of the vehicle will also deploy.

The tensioners can also be activated during a collision in which the front airbags *do not deploy*. In this case, the airbags would not be needed, but the additional restraint could be helpful.

When the tensioners are activated, the seat belts will remain tight until they are unbuckled.

Seat Belt Maintenance

For safety, you should check the condition of your seat belts regularly.

Pull each belt out fully, and look for frays, cuts, burns, and wear. Check that the latches work smoothly and the belts retract easily. If a belt does not retract easily, cleaning the belt may correct the problem (see page 203). Any belt that is not in good condition or working properly will not provide good protection and should be replaced as soon as possible.

Honda provides a limited warranty on seat belts. See your *Honda Warranty Information* booklet for details.

If a seat belt is worn during a crash, it must be replaced by your dealer. A belt that has been worn during a crash may not provide the same level of protection in a subsequent crash.

The dealer should also inspect the anchors for damage and replace them if needed. If the automatic seat belt tensioners activate during a crash, they must be replaced.

WARNING

Not checking or maintaining seat belts can result in serious injury or death if the seat belts do not work properly when needed.

Check your seat belts regularly, and have any problem corrected as soon as possible.

Airbag System Components

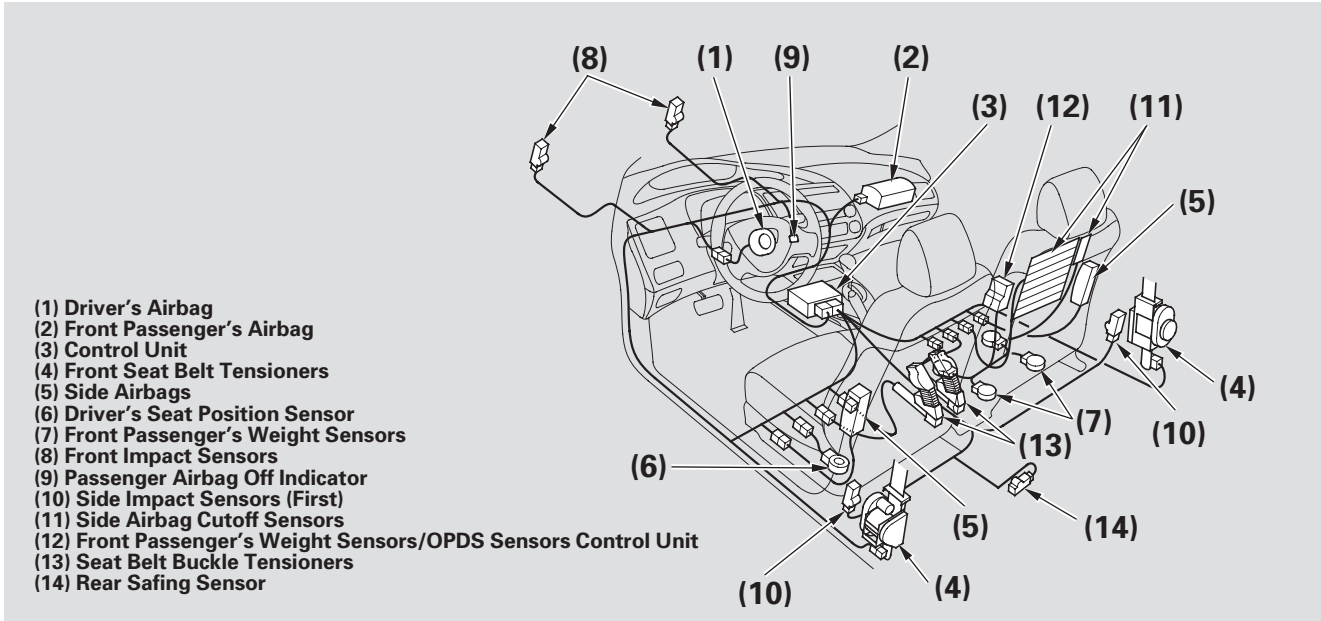

CONTINUED

Additional Information About Your Airbags

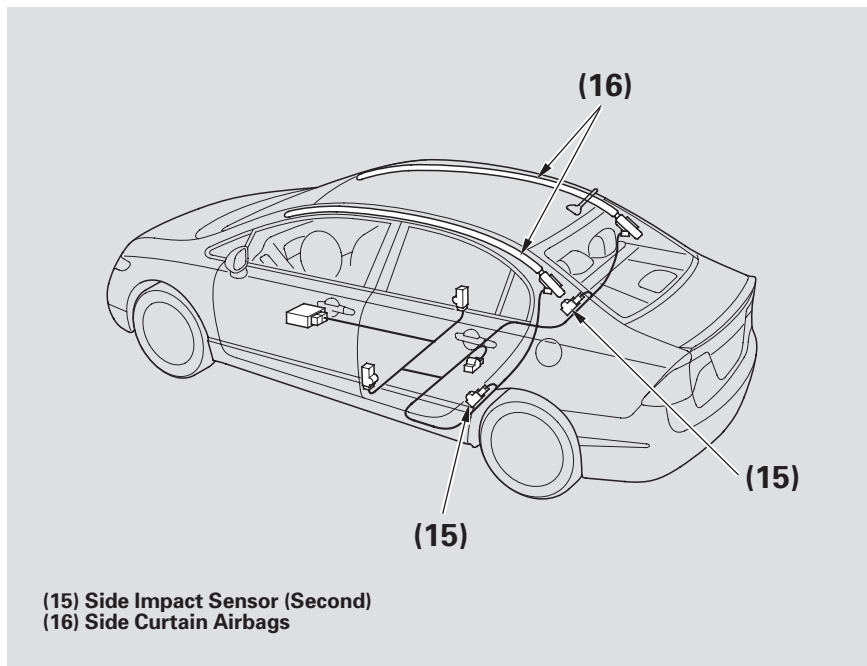

Your Airbag System includes:

- Two SRS (supplemental restraint system) front airbags. The driver's airbag is stored in the center of the steering wheel; the front passenger's airbag is stored in the dashboard. Both are marked "SRS AIRBAG" (see page [24](#)).
- Two side airbags, one for the driver and one for a front passenger. The airbags are stored in the outer edges of the seat-backs. Both are marked "SIDE AIRBAG" (see page [28](#)).
- Two side curtain airbags, one for each side of the vehicle. The airbags are stored in the ceiling, above the side windows. The front and rear pillars are marked "SIDE CURTAIN AIRBAG" (see page [29](#)).

- Automatic front seat belt tensioners (see page 19).
- Sensors that can detect a moderate to severe front impact or side impact.
- Sensors that can detect whether a small person or child is in the passenger's side airbag path and signal the control unit to turn the airbag off (see page 31).
- Sensors that can detect whether the driver's seat belt and a front passenger's seat belt is latched or unlatched (see page 18).
- A driver's seat position sensor that monitors the distance of the seat from the front airbag. If the seat is too far forward, the airbag will inflate with less force (see page 26).
- Sensors that monitor the weight on the front passenger's seat. If the weight is about 65 lbs (29 kg) or less (the weight of an infant or small child), the passenger's front airbag will be turned off (see page 26).
- A sophisticated electronic system that continually monitors and records information about the sensors, the control unit, the airbag activators, the seat belt tensioners, and driver and front passenger seat belt use when the ignition switch is in the ON (II) position.
- An indicator on the instrument panel that alerts you to a possible problem with your airbags, sensors, or seat belt tensioners (see page 30).
- An indicator on the instrument panel that alerts you that the passenger's side airbag has been turned off (see page 30).
- An indicator on the dashboard that alerts you that the passenger's front airbag has been turned off (see page 31).
- Emergency backup power in case your vehicle's electrical system is disconnected in a crash.

Additional Information About Your Airbags

How Your Front Airbags Work

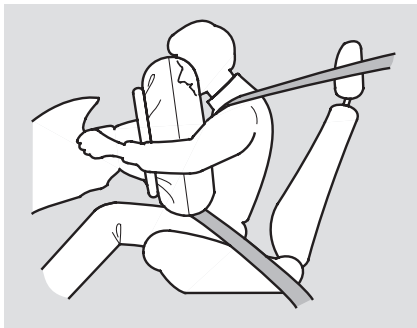

If you ever have a moderate to severe frontal collision, sensors will detect the vehicle's rapid deceleration.

If the rate of deceleration is high enough, the control unit will instantly inflate the driver's and front passenger's airbags, at the time and with the force needed.

During a frontal crash, your seat belt restrains your lower body and torso, and the front airbag helps protect your head and chest.

Although both airbags normally inflate within a split second of each other, it is possible for only one airbag to deploy.

This can happen if the severity of a collision is at the margin, or threshold, that determines whether or not the airbags will deploy. In such cases, the seat belt will provide sufficient protection, and the supplemental protection offered by the airbag would be minimal.

Only the driver's airbag will deploy if there is no passenger in the front seat, or if the advanced airbag system has turned the passenger's airbag off (see page 31).

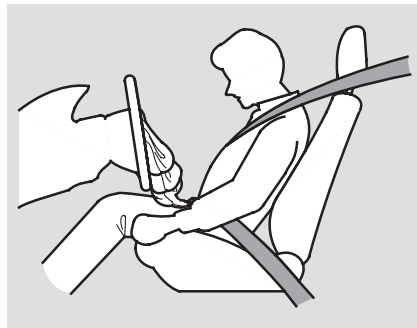

After inflating, the front airbags immediately deflate, so they won't interfere with the driver's visibility, or the ability to steer or operate other controls.

The total time for inflation and deflation is one-tenth of a second, so fast that most occupants are not aware that the airbags deployed until they see them lying in their laps.

After a crash, you may see what looks like smoke. This is actually powder from the airbag's surface. Although the powder is not harmful, people with respiratory problems may experience some temporary discomfort. If this occurs, get out of the vehicle as soon as it is safe to do so.

Dual-Stage Airbags

Your front airbags are dual-stage airbags. This means they have two inflation stages that can be ignited sequentially or simultaneously, depending on crash severity.

In a ***more severe*** crash, both stages will ignite simultaneously to provide the quickest and greatest protection.

In a ***less severe*** crash, one stage will ignite first, then the second stage will ignite a split second later. This provides longer airbag inflation time with a little less force.

Dual-Threshold Airbags

Your front airbags are also dual-threshold airbags. Airbags with this feature have two deployment thresholds that depend on whether sensors detect the occupant is wearing a seat belt or not.

If the occupant's belt is ***not latched***, the airbag will deploy at a slightly lower threshold, because the occupant would need extra protection.

If the occupant's belt is ***latched***, the airbag will inflate at a slightly higher threshold, when the airbag would be needed to supplement the protection provided by the seat belt.

CONTINUED

Additional Information About Your Airbags

Advanced Airbags

Your front airbags are also advanced airbags. The main purpose of this feature is to help prevent airbag-caused injuries to short drivers and children who ride in front.

For both advanced airbags to work properly:

- Occupants must sit upright and wear their seat belts properly.
- Do not spill any liquids on or under the seats, cover the sensors, or put any objects or metal items under the front seats.
- Back-seat passengers should not put their feet under the front seats.

Failure to follow these instructions could damage the sensors or prevent them from working properly.

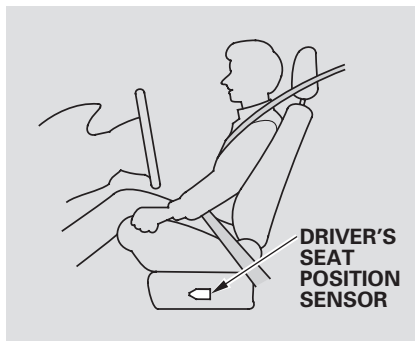

The driver's advanced front airbag system includes a seat position sensor under the seat. If the seat is too far forward, the airbag will inflate with less force, regardless of the severity of the impact.

If there is a problem with the sensor, the SRS indicator will come on, and the airbag will inflate in the normal manner regardless of the driver's seating position.

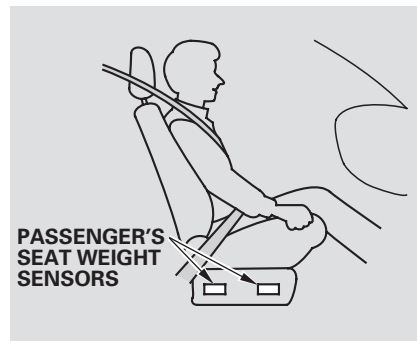

The passenger's advanced front airbag system has weight sensors under the seat. Although Honda does not encourage carrying an infant or small child in front, if the sensors detect the weight of an infant or small child (up to about 65 lbs or 29 kg), the system will automatically turn the passenger's front airbag off. Be aware that objects placed on the passenger's seat can also cause the airbag to be turned off.

When the airbag is turned off, a “passenger airbag off” indicator in the center of the dashboard comes on (see page 31).

If the weight sensors detect there is no passenger in the front seat, the airbag will be off. However, the passenger airbag off indicator will not come on.

To ensure that the passenger’s advanced front airbag system will work properly, ***do not do anything that would increase or decrease the weight on the front passenger’s seat.*** This includes:

- A rear passenger pushing or pulling on the back of the front passenger’s seat.

- Moving the front seat forcibly back against cargo on the seat or floor behind it.
- Hanging heavy items on the front passenger seat, or placing heavy items in the seat-back pocket.

If equipped

Also, make sure the floor mat behind the front passenger’s seat is hooked to the floor mat anchor (see page 203). If it is not, the mat may interfere with the proper operation of the sensors and operation of the seat.

Additional Information About Your Airbags

How Your Side Airbags Work

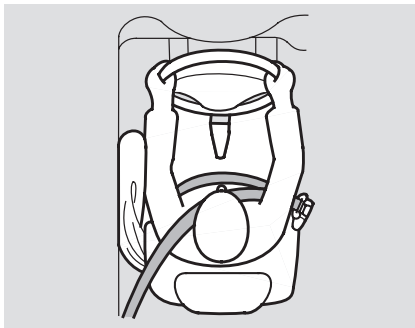

If you ever have a moderate to severe side impact, sensors will detect rapid acceleration and signal the control unit to instantly inflate either the driver's or the passenger's side airbag and activate the seat belt tensioner on the affected side.

Only one airbag will deploy during a side impact. If the impact is on the passenger's side, the passenger's side airbag will deploy even if there is no passenger.

To get the best protection from the side airbags, front seat occupants should wear their seat belts and sit upright and well back in their seats.

Side Airbag Cutoff System

Your vehicle has a side airbag cutoff system designed primarily to protect a child riding in the front passenger's seat.

Although Honda does not encourage children to ride in front, if sensors in the seat detect a child has leaned into the side airbag's deployment path, the airbag will shut off.

The side airbag may also shut off if a short adult leans sideways, or a larger adult slouches and leans sideways into the airbag's deployment path.

Objects placed on the front passenger seat can also cause the side airbag to be shut off.

If the side airbag off indicator comes on (see page 31), have the passenger sit upright. Once the passenger is out of the airbag's deployment path, the system will turn the airbag back on, and the indicator will go out.

There will be some delay between the moment the passenger moves into or out of the airbag deployment path and when the indicator comes on or goes off.

A front seat passenger should not use a cushion or other object as a backrest. It may prevent the cutoff system from working properly.

How Your Side Curtain Airbags Work

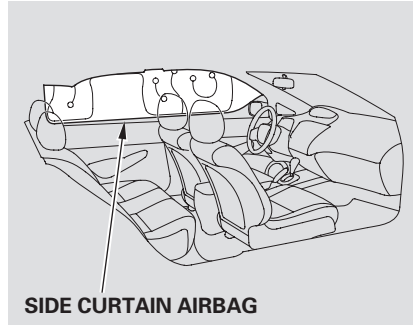

In a moderate to severe side impact, sensors will detect rapid acceleration and signal the control unit to instantly inflate the side curtain airbag and activate the seat belt tensioner on the driver's or the passenger's side of the vehicle.

If the impact is on the passenger's side, the passenger's side curtain airbag will inflate even if there are no occupants on that side of the vehicle.

To get the best protection from the side curtain airbags, occupants should wear their seat belts and sit upright and well back in their seats.

Additional Information About Your Airbags

How the SRS Indicator Works



The SRS indicator alerts you to a potential problem with your airbags or seat belt tensioners (see page 19).

When you turn the ignition switch to the ON (II) position, this indicator comes on for several seconds then goes off. This tells you the system is working properly.

If the indicator comes on at any other time, or does not come on at all, you should have the system checked by your dealer. For example:

- If the SRS indicator does not come on after you turn the ignition switch to the ON (II) position.
- If the indicator stays on after the engine starts.
- If the indicator comes on or flashes on and off while you drive.

⚠ WARNING

Ignoring the SRS indicator can result in serious injury or death if the airbag systems or tensioners do not work properly.

Have your vehicle checked by a dealer as soon as possible if the SRS indicator alerts you to a possible problem.

If you see any of these indications, the airbags and seat belt tensioners may not work properly when you need them.

How the Side Airbag Off Indicator Works

U.S.

Canada



This indicator alerts you that the passenger's side airbag has been automatically shut off. It does **not** mean there is a problem with your side airbags.

When you turn the ignition switch to the ON (II) position, the indicator should come on for several seconds and then go off (see page 59). If it doesn't come on, stays on, or comes on while driving without a passenger in the front seat, have the system checked.

How the Passenger Airbag Off Indicator Works

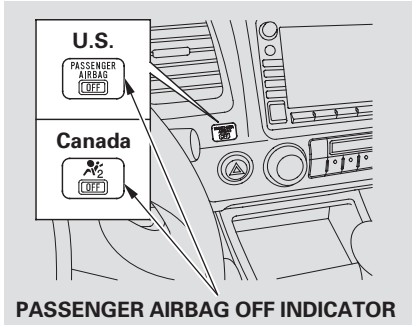

This indicator alerts you that the passenger's front airbag has been shut off because weight sensors detect about 65 lbs (29 kg) or less (the weight of an infant or small child) on the front passenger's seat. It does **not mean** there is a problem with the airbag.

Be aware that objects placed on the front seat can cause the indicator to come on.

If no weight is detected on the front seat, the airbag will be automatically shut off. However, the indicator will not come on.

The passenger airbag off indicator may come on and off repeatedly if the total weight on the seat is near the airbag cutoff threshold.

If an adult or teenage passenger is riding in front, move the seat as far to the rear as possible, and have the passenger sit upright and wear the seat belt properly.

If the indicator comes on with no front seat passenger and no objects on the seat, or with an adult riding there, something may be interfering with the weight sensors. Look for and remove:

- Any items under the front passenger's seat.
- Any object hanging on the seat or in the seat-back pocket.
- Any object on the floor that is touching the rear of the seat-back.

If no obstructions are found, have your vehicle checked by a dealer as soon as possible.

Additional Information About Your Airbags

Airbag Service

Your airbag systems are virtually maintenance free, and there are no parts you can safely service.

However, you must have your vehicle serviced if:

- ***An airbag ever inflates.*** Any airbag that has deployed must be replaced along with the control unit and other related parts. Any seat belt tensioner that activates must also be replaced.

Do not try to remove or replace any airbag by yourself. This must be done by an authorized dealer or a knowledgeable body shop.

- ***The SRS indicator alerts you to a problem.*** Take your vehicle to an authorized dealer as soon as possible. If you ignore this indication, your airbags may not operate properly.
- ***If your vehicle has a moderate to severe impact.*** Even if your airbags do not inflate, your dealer should inspect the driver's seat position sensor, the front passenger's weight sensors, the front seat belt tensioners, and all seat belts worn during the crash to make sure they are operating properly.

Additional Safety Precautions

- ***Do not attempt to deactivate your airbags.*** Together, airbags and seat belts provide the best protection.
- ***Do not tamper with airbag components or wiring for any reason.*** Tampering could cause the airbags to deploy, possibly causing very serious injury.

- ***Do not remove or modify a front seat without consulting your dealer.*** This could make the driver's seat position sensor or the front passenger's weight sensors ineffective. If it is necessary to remove or modify a front seat to accommodate a person with disabilities, first contact Honda Automobile Customer Service at (800) 999-1009.
- ***Do not cover or replace front seat-back covers without consulting your dealer.*** Improperly replacing or covering front seat-back covers can prevent your side airbags from inflating during a side impact.
- ***Do not expose the front passenger's seat-back to liquid.*** If water or another liquid soaks into a seat-back, it can prevent the side airbag cutoff system from working properly.



Children depend on adults to protect them. However, despite their best intentions, many adults do not know how to *properly* protect child passengers.

If you have children, or ever need to drive with a child in your vehicle, be sure to read this section. It begins with important general guidelines, then presents special information for infants, small children, and larger children.

All Children Must Be Restrained

Each year, many children are injured or killed in vehicle crashes because they are either unrestrained or not properly restrained. In fact, vehicle accidents are the number one cause of the death of children age 12 and under.

To reduce the number of child deaths and injuries, every state and Canadian province requires that infants and children be properly restrained when they ride in a vehicle.

Infants and small children must be restrained in an approved child seat that is properly secured to the vehicle (see pages 39 – 47).

⚠ WARNING

Children who are unrestrained or improperly restrained can be seriously injured or killed in a crash.

Any child too small for a seat belt should be properly restrained in a child seat. A larger child should be properly restrained with a seat belt and use a booster seat if necessary.

Larger children must be restrained with a lap/shoulder belt and ride on a booster seat until the seat belt fits them properly (see pages 48 – 51).

All Children Should Sit in a Back Seat

According to accident statistics, children of all ages and sizes are safer when they are restrained in a back seat.

The National Highway Traffic Safety Administration and Transport Canada recommend that all children aged 12 and under be properly restrained in a back seat. Some states have laws restricting where children may ride.

Children who ride in back are less likely to be injured by striking interior vehicle parts during a collision or hard braking. Also, children cannot be injured by an inflating front airbag when they ride in the back.

The Passenger's Front Airbag Can Pose Serious Risks

Front airbags have been designed to help protect adults in a moderate to severe frontal collision. To do this, the passenger's front airbag is quite large, and it can inflate with enough force to cause very serious injuries.

Even though your vehicle has an advanced front airbag system that automatically turns the passenger's front airbag off (see page 31), please follow these guidelines:

Infants

Never put a rear-facing child seat in the front seat of a vehicle equipped with a passenger's front airbag. If the airbag inflates, it can hit the back of the child seat with enough force to kill or very seriously injure an infant.

Small Children

Placing a forward-facing child seat in the front seat of a vehicle equipped with passenger's front airbag can be hazardous. If the vehicle seat is too far forward, or the child's head is thrown forward during a collision, an inflating front airbag can strike the child with enough force to kill or very seriously injure a small child.

Larger Children

Children who have outgrown child seats are also at risk of being injured or killed by an inflating passenger's front airbag. Whenever possible, larger children should sit in the back seat, on a booster seat if needed, and be properly restrained with a seat belt. (See page 48 for important information about protecting larger children.)

CONTINUED

Protecting Children – General Guidelines

To remind you of the passenger's front airbag hazards, and that children must be properly restrained in a back seat, your vehicle has warning labels on the dashboard (U.S. models) and on the front visors. Please read and follow the instructions on these labels.

U.S. Models

SUN VISORS



Canadian Models

SUN VISORS

CAUTION

TO AVOID SERIOUS INJURY:

- FOR MAXIMUM SAFETY PROTECTION IN ALL TYPES OF CRASHES, YOU MUST ALWAYS WEAR YOUR SAFETY BELT.
- DO NOT INSTALL REARWARD-FACING CHILD SEATS IN ANY FRONT PASSENGER SEAT POSITION.
- DO NOT SIT OR LEAN UNNECESSARILY CLOSE TO THE AIR BAG.
- DO NOT PLACE ANY OBJECTS OVER THE AIR BAG OR BETWEEN THE AIR BAG AND YOURSELF.
- SEE THE OWNER'S MANUAL FOR FURTHER INFORMATION AND EXPLANATIONS.

DASHBOARD

This Vehicle is Equipped with
Advanced Air Bags

Even with Advanced Air Bags

Children can be killed or seriously injured by the air bag.
The back seat is the safest place for children.
Never put a rear-facing child seat in the front.
Always use seat belts and child restraints.
See owner's manual for more information about air bags.

To be removed by owner only.

PRECAUTIONS:

- POUR EVITER DES BLESSURES GRAVES: POUR PROFITER D'UNE PROTECTION MAXIMALE LORS D'UNE COLLISION BOUCLEZ TOUJOURS VOTRE CEINTURE DE SECURITE.
- N'INSTALLEZ JAMAIS UN SIEGE POUR ENFANTS FAISANT FACE A L'ARRIERE SUR LE SIEGE DU PASSAGER AVANT.
- NE VOUS APPUYEZ PAS ET NE VOUS ASSOYEZ PAS PRES DU COUSSIN GONFLABLE.
- NE DEPOSEZ AUCUN OBJET SUR LE COUSSIN GONFLABLE OU ENTRE LE COUSSIN GONFLABLE ET VOUS.
- LISEZ LE GUIDE UTILISATEUR POUR DE PLUS AMPLES RENSEIGNEMENTS.

If You Must Drive with Several Children

Your vehicle has a back seat where children can be properly restrained. If you ever have to carry a group of children, and a child must ride in front:

- Place the largest child in the front seat, provided the child is large enough to wear the lap/shoulder belt properly (see page [48](#)).
- Move the vehicle seat as far to the rear as possible (see page [89](#)).
- Have the child sit upright and well back in the seat (see page [15](#)).
- Make sure the seat belt is properly positioned and secured (see page [14](#)).

If a Child Requires Close Attention

Many parents say they prefer to put an infant or a small child in the front passenger seat so they can watch the child, or because the child requires attention.

Placing a child in the front seat exposes the child to hazards in a frontal collision, and paying close attention to a child distracts the driver from the important tasks of driving, placing both of you at risk.

If a child requires close physical attention or frequent visual contact, we strongly recommend that another adult ride with the child in the back seat. The back seat is far safer for a child than the front.

Additional Safety Precautions

- **Never hold an infant or child on your lap.** If you are not wearing a seat belt in a crash, you could be thrown forward and crush the child against the dashboard or a seat-back. If you are wearing a seat belt, the child can be torn from your arms and be seriously hurt or killed.
- **Never put a seat belt over yourself and a child.** During a crash, the belt could press deep into the child and cause serious or fatal injuries.
- **Never let two children use the same seat belt.** If they do, they could be very seriously injured in a crash.
- **Use the childproof door locks to prevent children from opening the rear doors.** This can prevent children from accidentally falling out (see page 81).

- **Make sure any unused seat belt that a child can reach is buckled, the lockable retractor is activated, and the belt is fully retracted and locked.** If a child wraps a loose seat belt around their neck, they can be seriously or fatally injured. (See pages 45 and 46 for how to activate and deactivate the lockable retractor.)

- **Do not leave children alone in a vehicle.** Leaving children without adult supervision is illegal in most states and Canadian provinces, and can be very hazardous.

For example, infants and small children left in a vehicle on a hot day can die from heatstroke. A child left alone with the key in the ignition switch can accidentally set the vehicle in motion, possibly injuring themselves or others.

- **Lock all doors and the trunk when your vehicle is not in use.** Children who play in vehicles can accidentally get trapped inside. Teach your children not to play in or around vehicles. Know how to operate the emergency trunk opener and decide if your children should be shown how to use this feature (see page 80).
- **Keep vehicle keys and remote transmitters out of the reach of children.** Even very young children learn how to unlock vehicle doors, turn on the ignition switch, and open the trunk, which can lead to accidental injury or death.

Protecting Infants

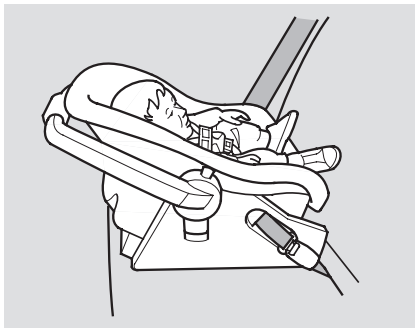

Child Seat Type

An infant must be properly restrained in a rear-facing, reclining child seat until the child reaches the seat maker's weight or height limit for the seat, and the child is at least one year old.

Only a rear-facing child seat provides proper support for a baby's head, neck, and back.

Two types of seats may be used: a seat designed exclusively for infants, or a convertible seat used in the rear-facing, reclining mode.

Do not put a rear-facing child seat in a forward-facing position. If placed facing forward, an infant could be very seriously injured during a frontal collision.

Child Seat Placement

A rear-facing child seat can be placed in any seating position in the back seat, but not in the front. ***Never put a rear-facing child seat in the front seat.***

If the passenger's front airbag inflates, it can hit the back of the child seat with enough force to kill or seriously injure an infant.

When properly installed, a rear-facing child seat may prevent the driver or a front passenger from moving their seat as far back as recommended, or from locking their seat-back in the desired position.

It can also interfere with proper operation of the passenger's advanced front airbag system.

CONTINUED

Protecting Infants and Small Children

In any of these situations, we strongly recommend that you install the child seat directly behind the front passenger's seat, move the seat as far forward as needed, and leave it unoccupied. Or, you may wish to get a smaller rear-facing child seat.

⚠ WARNING

Placing a rear-facing child seat in the front seat can result in serious injury or death if the passenger's front airbag inflates.

Always place a rear-facing child seat in the back seat, not the front.

Protecting Small Children



Child Seat Type

A child who is at least one year old, and who fits within the child seat maker's weight and height limits, should be restrained in a forward-facing, upright child seat.

Of the different seats available, we recommend those that have a five-point harness system as shown.

We also recommend that a small child use the child seat as long as possible, until the child reaches the weight or height limit for the seat.

Child Seat Placement

We strongly recommend placing a forward-facing child seat in a back seat, not the front.

Placing a forward-facing child seat in the front seat of a vehicle equipped with a passenger's airbag can be hazardous. If the vehicle seat is too far forward, or the child's head is thrown forward during a collision, an inflating airbag can strike the child with enough force to cause very serious or fatal injuries.

Even with advanced front airbags, which can automatically turn the passenger's front airbag off (see page 31), a back seat is the safest place for a small child.

If it is necessary to put a forward-facing child seat in the front, move the vehicle seat as far to the rear as possible, and be sure the child seat is firmly secured to the vehicle and the child is properly strapped in the seat.

⚠ WARNING

Placing a forward-facing child seat in the front seat can result in serious injury or death if the front airbag inflates.

If you must place a forward-facing child seat in front, move the vehicle seat as far back as possible, and properly restrain the child.

Selecting a Child Seat

When buying a child seat, you need to choose either a conventional child seat, or one designed for use with the lower anchors and tethers for children (LATCH) system.

Conventional child seats must be secured to a vehicle with a seat belt, whereas LATCH-compatible seats are secured by attaching the seat to hardware built into the two outer seating positions in the back seat.

Since LATCH-compatible child seats are easier to install and reduce the possibility of improper installation, we recommend selecting this style.

In seating positions and vehicles not equipped with LATCH, a LATCH-compatible child seat can be installed using a seat belt.

Whatever type of seat you choose, to provide proper protection, a child seat should meet three requirements:

- 1. The child seat should meet U.S. or Canadian Motor Vehicle Safety Standard 213.*** Look for FMVSS 213 or CMVSS 213 on the box.
- 2. The child seat should be of the proper type and size to fit the child.*** Rear-facing for infants, forward-facing for small children.
- 3. The child seat should fit the vehicle seating position (or positions) where it will be used.***

CONTINUED

Selecting a Child Seat, Installing a Child Seat

Before purchasing a conventional child seat, or using a previously purchased one, we recommend that you test the seat in the specific vehicle seating position or positions where the seat will be used.

Installing a Child Seat

After selecting a proper child seat and a good place to install the seat, there are three main steps in installing the seat:

1. Properly secure the child seat to the vehicle. All child seats must be secured to the vehicle with the lap part of a lap/shoulder belt or with the LATCH (lower anchors and tethers for children) system. A child whose seat is not properly secured to the vehicle can be endangered in a crash.

2. Make sure the child seat is firmly secured. After installing a child seat, push and pull the seat forward and from side-to-side to verify that it is secure.

A child seat secured with a seat belt should be installed as firmly as possible. However, it does not need to be “rock solid.” Some side-to-side

movement can be expected and should not reduce the child seat’s effectiveness.

If the child seat is not secure, try installing it in a different seating position, or use a different style of child seat that can be firmly secured.

3. Secure the child in the child seat.

Make sure the child is properly strapped in the child seat according to the child seat maker’s instructions. A child who is not properly secured in a child seat can be seriously injured in a crash.

The following pages provide guidelines on how to properly install a child seat. A forward-facing child seat is used in all examples, but the instructions are the same for a rear-facing child seat.

Installing a Child Seat with LATCH

Your vehicle is equipped with LATCH (lower anchors and tethers for children) at the outer rear seats.

The lower anchors are located between the seat-back and seat bottom, and are to be used only with a child seat designed for use with LATCH.

The location of each lower anchor is indicated by a small button above the anchor point.

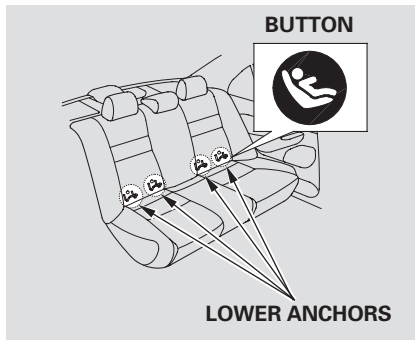

To install a LATCH-compatible child seat:

1. Move the seat belt buckle or tongue away from the lower anchors.
2. Make sure there are no objects near the anchors that could prevent a secure connection between the child seat and the anchors.

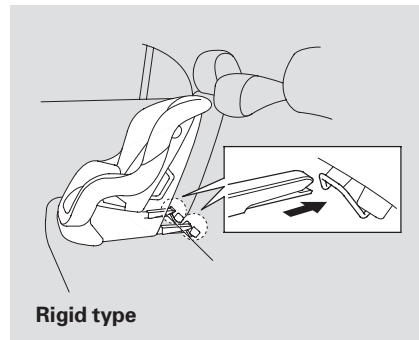

3. Place the child seat on the vehicle seat, then attach the seat to the lower anchors according to the child seat maker's instructions.

Some LATCH-compatible seats have a rigid-type connector as shown above.

CONTINUED

Installing a Child Seat

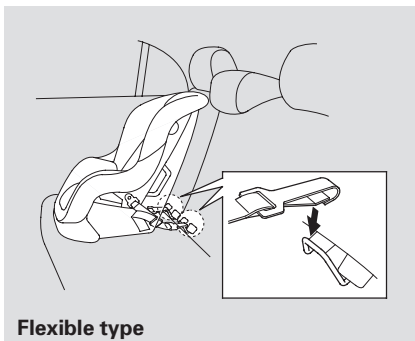

Other LATCH-compatible seats have a flexible-type connector as shown above.

4. Whatever type you have, follow the child seat maker's instructions for adjusting or tightening the fit.

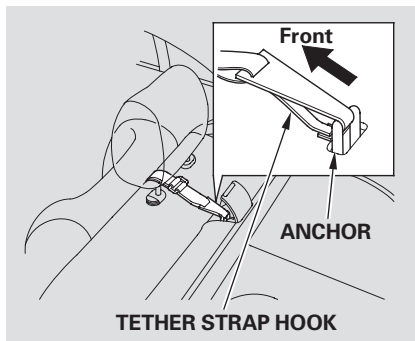

5. Lift the head restraint (see page 90), then route the tether strap through the legs of the head restraint and over the seat-back, making sure the strap is not twisted.
6. Tighten the strap according to the seat maker's instructions.

If the tether strap is too long and cannot be tightened firmly, find a route where the strap can be tightened securely.

7. Attach the tether strap hook to the tether anchor, then tighten the strap as instructed by the child seat maker.
8. Push and pull the child seat forward and from side-to-side to verify that it is secure.

Installing a Child Seat with a Lap/Shoulder Belt

When not using the LATCH system, all child seats must be secured to the vehicle with the lap part of a lap/shoulder belt.

In addition, the lap/shoulder belts in all seating positions except the driver's have a lockable retractor that must be activated to secure a child seat.

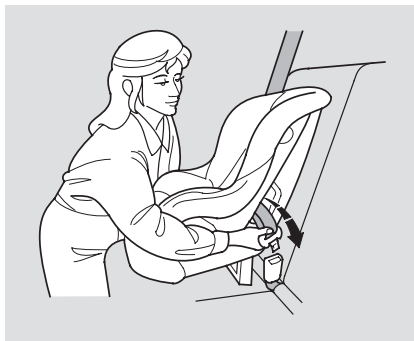

1. With the child seat in the desired seating position, route the belt through the child seat according to the seat maker's instructions, then insert the latch plate into the buckle.



2. To activate the lockable retractor, slowly pull the shoulder part of the belt all the way out until it stops, then let the belt feed back into the retractor.
3. After the belt has retracted, tug on it. If the belt is locked, you will not be able to pull it out. If you can pull the belt out, it is not locked, and you will need to repeat these steps.

CONTINUED

Installing a Child Seat



4. After confirming that the belt is locked, grab the shoulder part of the belt near the buckle, and pull up to remove any slack from the lap part of the belt. Remember, if the lap part of the belt is not tight, the child seat will not be secure.

To remove slack, it may help to put weight on the child seat, or push on the back of the seat while pulling up on the belt.



5. Push and pull the child seat forward and from side-to-side to verify that it is secure enough to stay upright during normal driving maneuvers. If the child seat is not secure, unlatch the belt, allow it to retract fully, then repeat these steps.

To deactivate the lockable retractor and remove a child seat, unlatch the buckle, unrout the seat belt, and let the belt fully retract.

Installing a Child Seat with a Tether

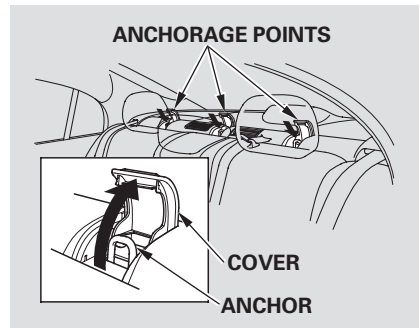

A child seat with a tether can be installed in any seating position in the back seat, using one of the anchorage points shown above.

Since a tether can provide additional security to the lap/shoulder belt installation, we recommend using a tether whenever one is required or available.

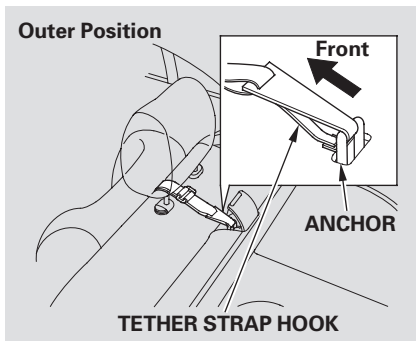

1. After properly securing the child seat (see page 45), lift the head restraint, then route the tether strap over the seat-back and through the head restraint legs.

If the tether strap is too long and cannot be tightened firmly, find a route where the strap can be tightened securely.

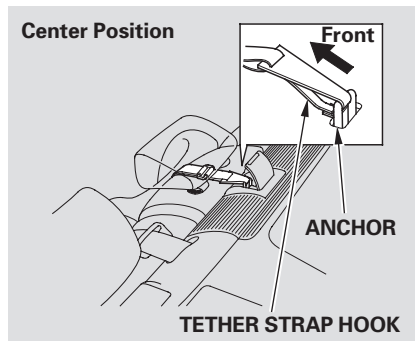

2. Lift the anchor cover, then attach the tether strap hook to the anchor, making sure the strap is not twisted.
3. Tighten the strap according to the seat maker's instructions.

Protecting Larger Children

When a child reaches the recommended weight or height limit for a forward-facing child seat, the child should sit in a back seat on a booster seat and wear a lap/shoulder belt.

The following pages give instructions on how to check proper seat belt fit, what kind of booster seat to use if one is needed, and important precautions for a child who must sit in front.

⚠ WARNING

Allowing a child age 12 or under to sit in front can result in injury or death if the passenger's front airbag inflates.

If a child must ride in front, move the vehicle seat as far back as possible, use a booster seat if needed, have the child sit up properly and wear the seat belt properly.

Checking Seat Belt Fit



To determine if a lap/shoulder belt properly fits a child, have the child put on the seat belt, then ask yourself:

1. Does the child sit all the way back against the seat?
2. Do the child's knees bend comfortably over the edge of the seat?

3. Does the shoulder belt cross between the child's neck and arm?
4. Is the lap part of the belt as low as possible, touching the child's thighs?
5. Will the child be able to stay seated like this for the whole trip?

If you answer yes to all these questions, the child is ready to wear the lap/shoulder belt correctly. If you answer no to any question, the child needs to ride on a booster seat.

Using a Booster Seat



A child who has outgrown a forward-facing child seat should ride in a back seat and use a booster seat until the lap/shoulder belt fits them properly without the booster.

Some states and Canadian provinces also require children to use a booster seat until they reach a given age or weight (e.g., 6 years or 60 lbs). Be sure to check current laws in the states or provinces where you intend

to drive.

Booster seats can be high-back or low-back. Whichever style you select, make sure the booster seat meets federal safety standards (see page 41) and that you follow the booster seat maker's instructions.

If a child who uses a booster seat must ride in front, move the vehicle seat as far back as possible, and be sure the child is wearing the seat belt properly.

A child may continue using a booster seat until the tops of their ears are even with the top of the vehicle's or booster's seat-back. A child of this height should be tall enough to use the lap/shoulder belt without a booster seat.

When Can a Larger Child Sit in Front

The National Highway Traffic Safety Administration and Transport Canada recommend that all children age 12 and under be properly restrained in the back seat.

If the passenger's front airbag inflates in a moderate to severe frontal collision, the airbag can cause serious injuries to a child who is unrestrained, improperly restrained, sitting too close to the airbag, or out of position.

A side airbag also poses risks. If any part of a larger child's body is in the path of a deploying side airbag, the child could receive possibly serious injuries.

Of course, children vary widely. And while age may be one indicator of when a child can safely ride in front, there are other important factors you should consider.

Physical Size

Physically, a child must be large enough for the lap/shoulder belt to properly fit (see pages 14 and 48). If the seat belt does not fit properly, with or without the child sitting on a booster seat, the child should not sit in front.

Maturity

To safely ride in front, a child must be able to follow the rules, including sitting properly, and wearing the seat belt properly throughout a ride.

If you decide that a child can safely ride up front, be sure to:

- Carefully read the owner's manual, and make sure you understand all seat belt instructions and all safety information.
- Move the vehicle seat to the rear-most position.
- Have the child sit up straight, back against the seat, and feet on or near the floor.
- Check that the child's seat belt is properly and securely positioned.
- Supervise the child. Even a mature child sometimes needs to be reminded to fasten the seat belt or sit properly.

Additional Safety Precautions

- ***Do not let a child wear a seat belt across the neck.*** This could result in serious neck injuries during a crash.
- ***Do not let a child put the shoulder part of a seat belt behind the back or under the arm.*** This could cause very serious injuries during a crash. It also increases the chance that the child will slide under the belt in a crash and be injured.
- ***Two children should never use the same seat belt.*** If they do, they could be very seriously injured in a crash.
- ***Do not put any accessories on a seat belt.*** Devices intended to improve a child's comfort or reposition the shoulder part of a seat belt can make the belt less effective and increase the chance of serious injury in a crash.

Carbon Monoxide Hazard

Your vehicle's exhaust contains carbon monoxide gas. Carbon monoxide should not enter the vehicle in normal driving if you maintain your vehicle properly and follow the information on this page.

Have the exhaust system inspected for leaks whenever:

- The vehicle is raised for an oil change.
- You notice a change in the sound of the exhaust.
- The vehicle was in an accident that may have damaged the underside.

WARNING

Carbon monoxide gas is toxic. Breathing it can cause unconsciousness and even kill you.

Avoid any enclosed areas or activities that expose you to carbon monoxide.

High levels of carbon monoxide can collect rapidly in enclosed areas, such as a garage. Do not run the engine with the garage door closed. Even with the door open, run the engine only long enough to move the vehicle out of the garage.

With the trunk open, airflow can pull exhaust gas into your vehicle's interior and create a hazardous condition. If you must drive with the trunk open, open all the windows, and set the heating and cooling system as shown below.

If you must sit in your parked vehicle with the engine running, even in an unconfined area, adjust the heating and cooling system as follows:

1. Select the fresh air mode.
2. Select the  mode.
3. Set the fan speed to high.
4. Set the temperature control to a comfortable setting.

These labels are in the locations shown. They warn you of potential hazards that could cause serious injury. Read these labels carefully.

If a label comes off or becomes hard to read (except for the U.S. dashboard label, which is removed by the owner), contact your dealer for a replacement.

DASHBOARD

U.S. models only

This Vehicle is Equipped with
Advanced Air Bags

Even with Advanced Air Bags

Children can be killed or seriously injured by the air bag.
The back seat is the safest place for children.
Never put a rear-facing child seat in the front.
Always use seat belts and child restraints.
See owner's manual for more information about air bags.

To be removed by owner only.

SUN VISORS

U.S. models



AIR BAG WARNING

FLIP VISOR OVER

WARNING

EVEN WITH ADVANCED AIR BAGS



- Children can be killed or seriously injured by the air bag
- The back seat is the safest place for children
- Never put a rear-facing child seat in the front
- Always use seat belts and child restraints
- See owner's manual for more information about air bags

Canadian models

CAUTION

- TO AVOID SERIOUS INJURY:
- FOR MAXIMUM SAFETY PROTECTION IN ALL TYPES OF CRASHES, YOU MUST ALWAYS WEAR YOUR SAFETY BELT.
- DO NOT INSTALL REARWARD-FACING CHILD SEATS IN ANY FRONT PASSENGER SEAT POSITION.
- DO NOT SIT OR LEAN UNNECESSARILY CLOSE TO THE AIR BAG.
- DO NOT PLACE ANY OBJECTS OVER THE AIR BAG OR BETWEEN THE AIR BAG AND YOURSELF.
- SEE THE OWNER'S MANUAL FOR FURTHER INFORMATION AND EXPLANATIONS.

PRECAUTIONS:

- POUR ÉVITER DES BLESSURES GRAVES:
- POUR PROFITER D'UNE PROTECTION MAXIMALE EN CAS D'UNE COLLISION, BOUCLEZ TOUJOURS VOTRE CEINTURE DE SÉCURITÉ.
- N'INSTALLEZ JAMAIS UN SIÈGE POUR ENFANTS FAISANT FACE À L'ARRIÈRE SUR LE SIÈGE DU PASSAGER AVANT.
- NE VOUS APPUYEZ PAS ET NE VOUS ASSOYEZ PAS PRES DU COUSSIN GONFLABLE.
- NE DÉPOSEZ AUCUN OBJET SUR LE COUSSIN GONFLABLE OU ENTRE LE COUSSIN GONFLABLE ET VOUS.
- LISEZ LE GUIDE UTILISATEUR POUR DE PLUS AMPLES RENSEIGNEMENTS.

RADIATOR CAP

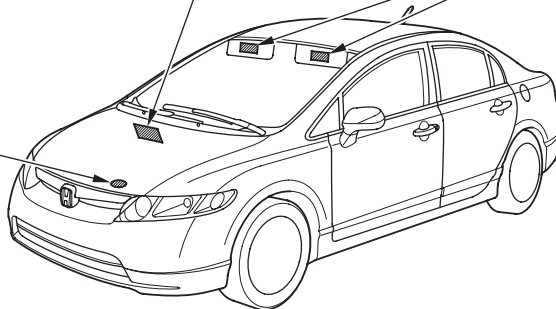

Safety Labels

HOOD

U.S. models

SUPPLEMENTAL RESTRAINT SYSTEM (SRS)

This vehicle is equipped with front airbags, side airbags in the front seats, front seatbelt tensilebars, and side curtain airbags. All SRS electrical wiring and connectors are colored yellow. Tampering with, disconnecting or using test equipment on the SRS wiring can make the system inoperative or cause accidental deployment.

▲ WARNING

Accidental deployment can seriously hurt or kill you. Follow Service Manual instructions carefully.

Canadian models

SUPPLEMENTAL RESTRAINT SYSTEM (SRS)

This vehicle is equipped with front airbags, side airbags in the front seats, front seatbelt tensilebars, and side curtain airbags. All SRS electrical wiring and connectors are colored yellow. Tampering with, disconnecting or using test equipment on the SRS wiring can make the system inoperative or cause accidental deployment.

▲ WARNING

Accidental deployment can seriously hurt or kill you. Follow Service Manual instructions carefully.

SYSTEME DE RETENUE SUPPLEMENTAIRE (SRS)

Cette véhicule est équipée de coussins gonflables latéraux, coussins gonflables avant et de dispositifs de tension de ceinture avant. Tous les câbles électriques et connecteurs du système SRS sont jaunes. L'altération ou le détachement des fils du système SRS ou l'usage d'équipement de test sur le système peut rendre le système inopérant ou provoquer un déploiement accidentaire.

▲ ATTENTION

Un déploiement accidentaire risque de causer graves blessures, voire la mort. Suivez attentivement les instructions du manuel de réparation.

HOOD

U.S. models

AIR CONDITIONER SYSTEM

REFRIGERANT: HC134a (SAE J639)
 RECHARGE: MAX. 4.0 g (15.0oz) MIN. 0.400 g (1.4oz)
 CAUTION: SYSTEM TO BE SERVICED BY A QUALIFIED PERSONNEL

▲ WARNING

Improper service can cause shock and death.
 Use "SE-10" oil only for this compressor.
 Follow instructions in service manual.

American Honda Motor Co., Inc. Torrance, CA 

Canadian models

AIR CONDITIONER SYSTEM

HFC134a (R134a)

▲  WARNING ▲  WAARSCHUWING

▲  ATTENTION ▲  VARNING

▲  WARNUNG ▲  ATENÇÃO

▲  ATTENZIONE ▲  ADVERTENCIA

Use "SE-10" oil only for this compressor.

DOORJAMBS

U.S. models

SIDE AIRBAG

- This car is equipped with side airbags in the front seats and side curtain airbags.
- Do not lean against the door.
- See owner's manual for more information.

Canadian models

SIDE AIRBAG

- This car is equipped with side airbags in the front seats and side curtain airbags.
- Do not lean against the door.
- See owner's manual for more information.

COUSSIN GONFLABLE LATERAL

- Cette automobile est équipée de coussins gonflables latéraux dans les sièges avant ainsi que de coussins gonflables latéraux de type rideau.
- Ne vous appuyez pas sur la porte.
- Consultez le Manuel du propriétaire pour en savoir plus.

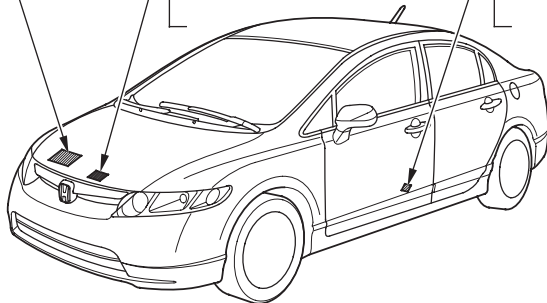

This section gives information about the controls and displays that contribute to the daily operation of your vehicle. All the essential controls are within easy reach.

Control Locations	56	Keys and Locks.....	76
Instrument Panel	57	Immobilizer System.....	78
Instrument Panel Indicators.....	58	Ignition Switch	79
Gauges	64	Door Locks	80
Odometer.....	64	Power Door Locks.....	80
Display Change Button.....	65	Childproof Door Locks	81
Current Fuel Mileage.....	65	Auto Door Locking/Unlocking..	81
Temperature Gauge.....	65	Auto Door Locking.....	81
Trip Meter	66	Auto Door Unlocking	83
Average Fuel Mileage.....	66	Trunk.....	86
Fuel Gauge	66	Emergency Trunk Opener	86
Outside Temperature		Remote Transmitter	87
Indicator.....	67	Seats	89
Check Fuel Cap Indicator.....	68	Power Windows	92
Maintenance Minder.....	68	Mirrors.....	93
IMA Battery Level Gauge	69	Parking Brake	94
Charge/Assist Gauge	70	Interior Convenience Items.....	95
Controls Near the Steering		Beverage Holder.....	96
Wheel	71	Accessory Power Socket	96
Windshield Wipers and Washers ..	72	Glove Box	96
Turn Signal and Headlights.....	73	Console Compartment	96
Daytime Running Lights.....	74	Interior Lights	97
Instrument Panel Brightness	74		
Hazard Warning Button.....	74		
Rear Window Defogger	75		
Steering Wheel Adjustment	75		

Control Locations

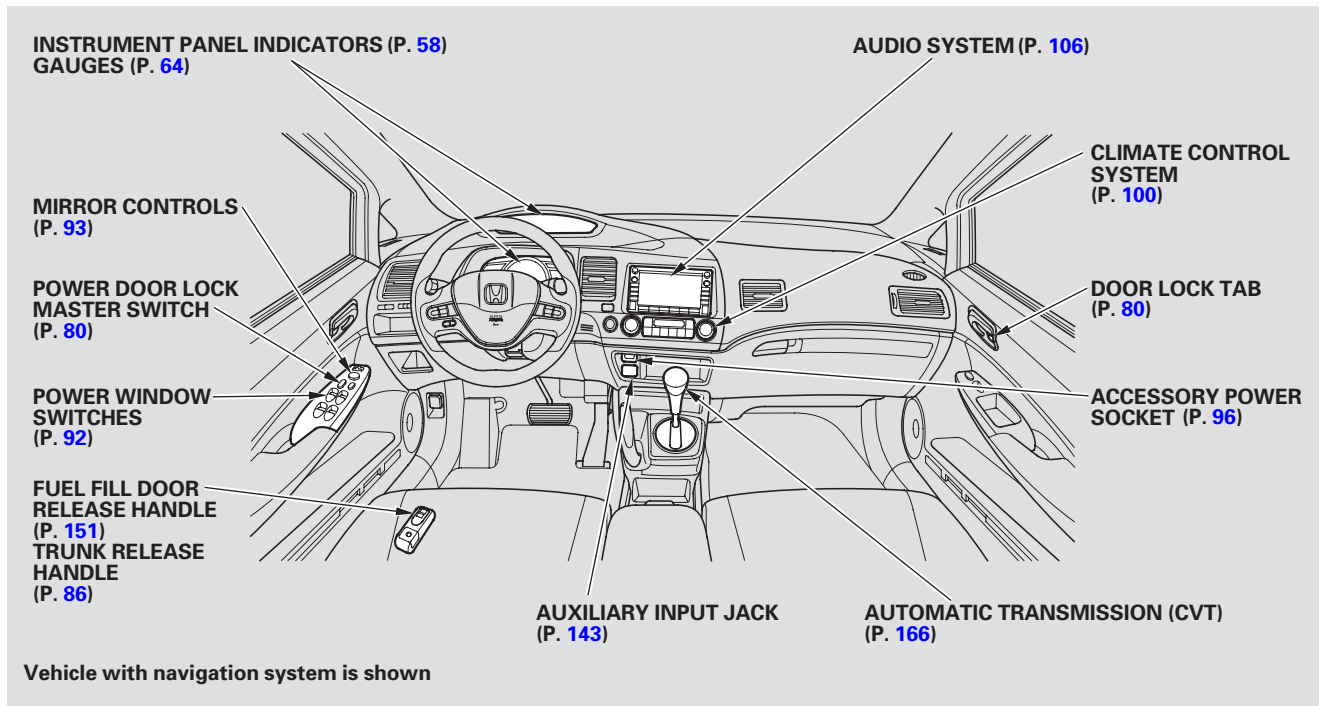

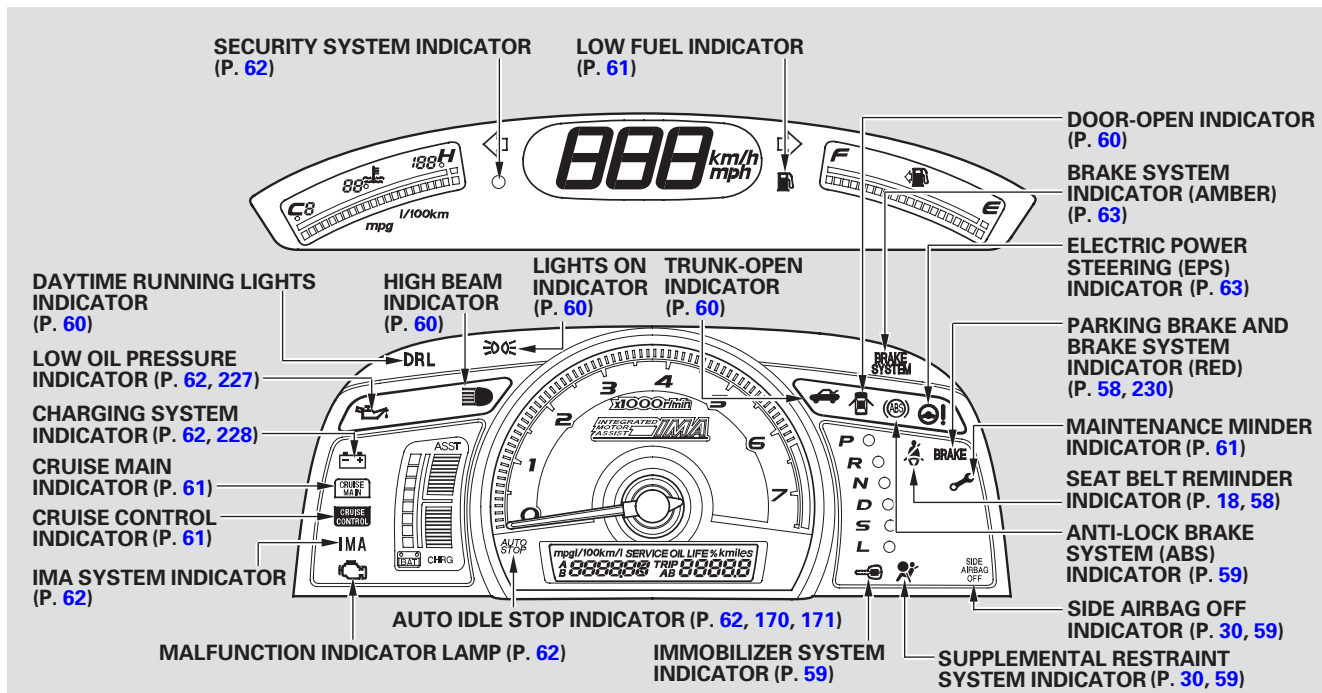

* The U.S. instrument panel is shown. Differences for the Canadian models are noted in the text.

Instrument Panel Indicators

The instrument panel has many indicators to give you important information about your vehicle.



Seat Belt Reminder Indicator

This indicator reminds you and your passengers to fasten your seat belts.

If you turn the ignition switch to the ON (II) position before fastening your seat belt, the beeper sounds and the indicator flashes. If you do not fasten your seat belt before the beeper stops, the indicator stops flashing but remains on.

If your front passenger does not fasten their seat belt, the indicator comes on about 6 seconds after the ignition switch is turned to the ON (II) position.

If either of you do not fasten your seat belt while driving, the beeper will sound and the indicator will flash again at regular intervals. For more information, see page [18](#).



This indicator has two functions:

1. It comes on when you turn the ignition switch to the ON (II) position. It is a reminder to check the parking brake. A beeper sounds if you drive with the parking brake not fully released. Driving with the parking brake not fully released can damage the brakes and tires.

2. If it stays on after you have fully released the parking brake while the engine is running, or if it comes on while driving, there could be a problem with the brake system. For more information, see page [230](#).



Supplemental Restraint System Indicator

This indicator comes on for several seconds when you turn the ignition switch to the ON (II) position. If it comes on at any other time, it indicates a potential problem with your front airbags. This indicator will also alert you to a potential problem with your side airbags, passenger's side airbag automatic cutoff system, side curtain airbags, automatic seat belt tensioners, driver's seat position sensor, or the front passenger's weight sensors. For more information, see page 30 .



Side Airbag Off Indicator

This indicator comes on for several seconds when you turn the ignition switch to the ON (II) position. If it comes on at any other time, it indicates that the passenger's side airbag has automatically shut off. For more information, see page 30 .



Anti-lock Brake System (ABS) Indicator

This indicator normally comes on for a few seconds when you turn the ignition switch to the ON (II) position. If it comes on at any other time, there is a problem with the ABS. If this happens, have your vehicle checked at a dealer. With this indicator on, your vehicle still has normal braking ability but no anti-lock function. For more information, see page 174 .



Immobilizer System Indicator

This indicator comes on briefly when you turn the ignition switch to the ON (II) position. It will then go off if you have inserted a properly-coded ignition key. If it is not a properly-coded key, the indicator will blink, and the engine's fuel system will be disabled (see page 78).

Instrument Panel Indicators



Turn Signal and Hazard Warning Indicators

The left or right turn signal indicator blinks when you signal a lane change or turn. If an indicator does not blink or blinks rapidly, it usually means one of the turn signal bulbs is burned out (see pages [199](#) and [200](#)). Replace the bulb as soon as possible, since other drivers cannot see that you are signaling.

When you press the hazard warning button, both turn signal indicators and all turn signals on the outside of the vehicle flash.



“Daytime Running Lights” Indicator

If this indicator comes on when the ignition switch is turned to the ON (II) position and the parking brake is released, it means there is a problem in a circuit. Have your vehicle checked by your dealer.





High Beam Indicator

This indicator comes on with the high beam headlights. For more information, see page [73](#).

This indicator also comes on with reduced brightness when the daytime running lights (DRL) are on (see page [74](#)).



Lights On Indicator

This indicator reminds you that the exterior lights are on. It comes on when the light switch is in either the  or  position. If you turn the ignition switch to the ACCESSORY (I) or the LOCK (0) position without turning off the light switch, this indicator will remain on. A reminder chime will also sound when you open the driver's door and remove the key from the ignition switch.



Trunk-open Indicator

This indicator comes on if the trunk lid is not closed tightly.



Door-open Indicator

This indicator comes on if any door is not closed tightly.



Cruise Main Indicator

This indicator comes on when you turn on the cruise control system by pressing the CRUISE button (see page [145](#)).



Cruise Control Indicator

This indicator comes on when you set the cruise control. See page [145](#) for information on operating the cruise control.



Washer Level Indicator

Canadian models only

This indicator comes on when the washer fluid level is low. Add washer fluid when you see this indicator come on (see page [194](#)).



Low Fuel Indicator

This indicator is in the fuel gauge. It comes on as a reminder that you must refuel soon. When the indicator comes on, there is about 0.9 US gal (3.5 ℓ) of fuel remaining in the tank before the reading reaches E. There is a small reserve of fuel remaining in the tank when the reading does reach E.



Maintenance Minder Indicator

This indicator reminds you that it is time to take your vehicle in for scheduled maintenance. The maintenance main items and sub items will be displayed in the information display. See page [179](#) for more information on the maintenance minder.

This indicator goes off when your dealer resets it after completing the required maintenance service.

Instrument Panel Indicators

Security System Indicator

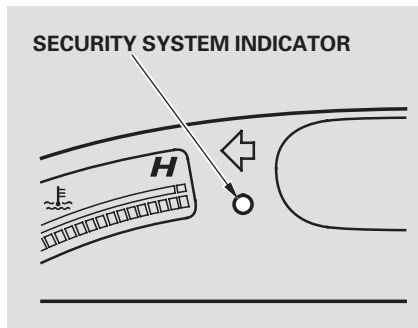

This indicator comes on when the security system is set. For more information, see page [144](#).



Malfunction Indicator Lamp

See page [229](#).



Low Oil Pressure Indicator

The engine can be severely damaged if this indicator flashes or stays on when the engine is running. For more information, see page [227](#).



Charging System Indicator

If this indicator comes on when the engine is running, the battery is not being charged. For more information, see page [228](#).



IMA System Indicator

This indicator normally comes on for a few seconds when you turn the ignition switch to the ON (II) position. If it comes on at any other time, it indicates a problem in the integrated motor assist (IMA) system. With the IMA indicator on, the vehicle may not accelerate as it normally does. Have the vehicle checked by the dealer as soon as possible.



Auto Idle Stop Indicator

See pages [170](#) and [171](#).



Electric Power Steering (EPS) Indicator

This indicator normally comes on when you turn the ignition to the ON (II) position and goes off after the engine starts. If it comes on at any other time, there is a problem in the electric power steering system. If this happens, stop the vehicle in a safe place and turn off the engine. Reset the system by restarting the engine. The indicator will not turn off immediately. If it does not go off after driving a short distance, or comes on again while driving, take the vehicle to your dealer to have it checked. With the indicator on, the EPS may be turned off, making the vehicle harder to steer.

If you turn the steering wheel to the full left or right position repeatedly while stopping or driving at very low speed, you may feel slightly harder steering due to overheating of the steering gear box.

Continuously driving under those conditions could damage the power steering system.

U.S.



Canada



Brake System Indicator (Amber)

This indicator normally comes on for a few seconds when you turn the ignition switch to the ON (II) position. When the brake system indicator (amber) is on, there is the problem with the Cooperative Control with regenerative brake, Creep Aid System or Brake Assist (the normal brake operates properly). Have your vehicle checked by your dealer.

For more information, see page [173](#).

Gauges

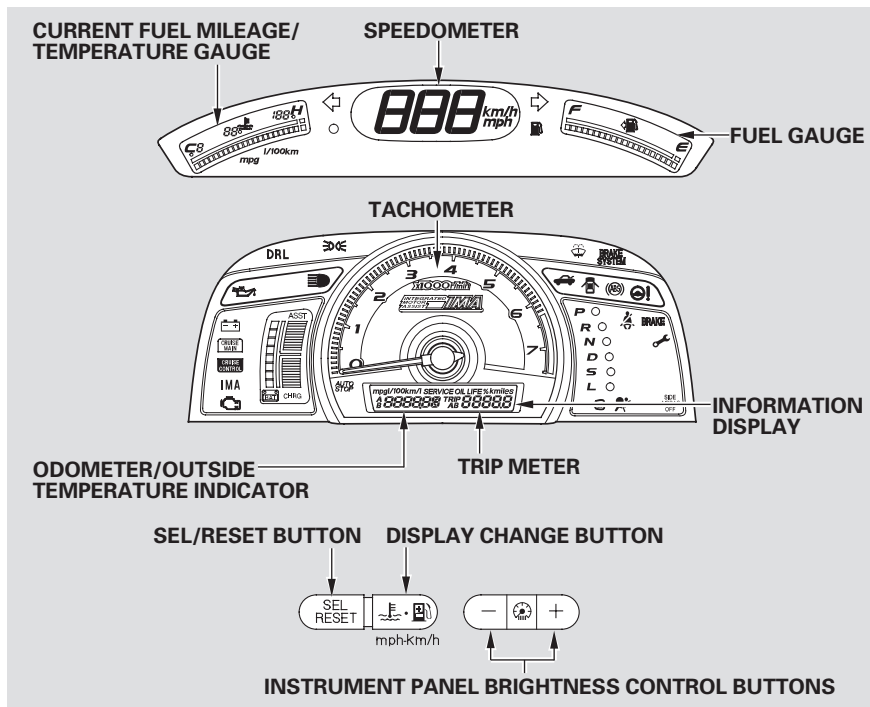

To switch the information display between the odometer, trip meter, outside temperature, and engine oil life and maintenance item code(s), press the SEL/RESET button repeatedly.

Odometer

The odometer shows the total distance your vehicle has been driven. It measures in miles or kilometers. It is illegal under U.S. federal law and Canadian provincial regulations to disconnect, reset, or alter the odometer with the intent to change the number of miles or kilometers indicated.

Display Change Button

Every time you press the display change button, the display changes from the current fuel mileage to the temperature gauge, or from the temperature gauge to the current fuel mileage.

Press and hold the display change button until you hear a beep. Each time you press the button, the speedometer, trip meter, average fuel mileage and current fuel mileage readings switches their measures.

Depending on the selected measures (mph or km/h), the trip meter and odometer readings are shown with miles or km. The average fuel mileage and current fuel mileage are shown with mpg or l/100 km.

Current Fuel Mileage

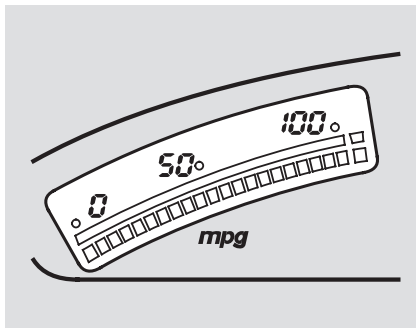

This display shows the current, or instant fuel mileage you are getting.

It shows the number of mpg or l/100 km.

Temperature Gauge

This shows the temperature of the engine's coolant. During normal operation, the reading should be in the middle of the gauge. In severe driving conditions, such as very hot weather or a long period of uphill driving, the reading may reach near the red mark. If it reaches the red (Hot) mark, pull safely to the side of the road. See page [225](#) for instructions and precautions on checking the engine's cooling system.

Gauges

Trip Meter

This meter shows the number of miles or kilometers driven since you last reset it.

There are two trip meters: TRIP A and TRIP B. Switch between these displays by pressing the SEL/RESET button repeatedly.

Each trip meter works independently, so you can keep track of two different distances.

To reset a trip meter, display it, and then press and hold the SEL/RESET button until the number resets to "0.0."

Average Fuel Mileage

When either of the trip meters (trip A or trip B) is displayed, your vehicle's average fuel mileage since you last reset that trip meter can be shown on the information display (mpg or l/100km). This number is updated once per 10 seconds. To see the average fuel mileage, press and release the SEL/RESET button repeatedly.

The average fuel mileage will be reset when you reset the trip meter, or if the vehicle's battery goes dead or is disconnected.

Fuel Gauge

This shows how much fuel you have. It may show slightly more or less than the actual amount.

NOTICE

Avoid driving with an extremely low fuel level. Running out of fuel could cause the engine to misfire, damaging the catalytic converter.

Outside Temperature Indicator

This indicator displays the outside temperature in Fahrenheit (U.S. models) or Centigrade (Canadian models). To see the outside temperature, press and release the SEL/RESET button until the temperature is shown on the information display.

The temperature sensor is in the front bumper. Therefore, the temperature reading can be affected by heat reflection from the road surface, engine heat, and the exhaust from surrounding traffic. This can cause an incorrect temperature reading when your speed is under 19 mph (30 km/h).

The sensor delays the display update until it reaches the correct outside temperature. This may take several minutes.

If the outside temperature is incorrectly displayed, you can adjust it up to $\pm 5^{\circ}\text{F}$ ($\pm 3^{\circ}\text{C}$) warmer or cooler.

NOTE: The temperature must be stabilized before doing this procedure.

Select the outside temperature display, then press the SEL/RESET button for 10 seconds. The following sequence will appear for 1 second each: 0, 1, 2, 3, 4, 5, -5, -4, -3, -2, -1, 0 (U.S.) or 0, 1, 2, 3, -3, -2, -1, 0 (Canada).

When it reaches the desired value, release the SEL/RESET button. You should see the new outside temperature displayed.

In certain weather conditions, temperature readings near freezing (32°F , 0°C) could mean that ice is forming on the road surface.

Check Fuel Cap Message

Your vehicle's on board diagnostic system will detect a loose or missing fuel fill cap as an evaporative system leak. The first time a leak is detected a "CHECK FUEL CAP" message appears on the information display. Turn the engine off, and confirm the fuel fill cap is installed. If it is, loosen it, then retighten it until it clicks at least once. The message should go off after several days of normal driving once you tighten or replace the fuel fill cap. To scroll to another display, press the SEL/RESET button. The "CHECK FUEL CAP" message will appear each time you restart the engine until the system turns the message off.

If the system still detects a leak in the vehicle's evaporative emissions system, the malfunction indicator lamp (MIL) comes on. If the fuel fill cap was not already tightened, turn the engine off, and check or retighten the fuel fill cap until it clicks at least once. The MIL should go off after several days of normal driving once the cap is tightened or replaced. If the MIL does not go off, have your vehicle inspected by a dealer. For more information, see page [229](#) .

Maintenance Minder

The information display in the instrument panel shows you the engine oil life and maintenance service items when the ignition switch is in the ON (II) position. This information helps to keep you aware of the periodic maintenance your vehicle needs for continued trouble-free driving. Refer to page [179](#) for more information.

IMA Battery Level Gauge

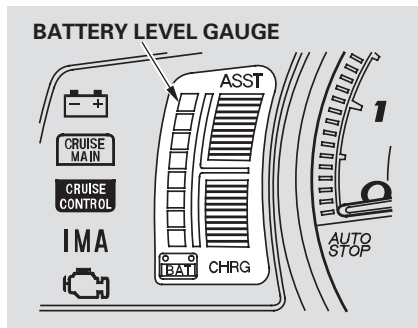

This gauge shows you the state of charge of the battery for the Integrated Motor Assist (IMA). This battery is recharged by the IMA motor, and discharged by the IMA when it is assisting the engine with powering the vehicle.

The gauge reading may drop near the bottom under driving conditions that require IMA motor assistance for a long time, such as prolonged

acceleration or climbing a long hill. The IMA motor will recharge the battery as you continue driving.

If the battery is mostly discharged, the Auto Idle Stop function is disabled (see page 170).

The battery level gauge does not read the battery level directly. It calculates the level by continuously measuring the current flow, voltage, and temperature.

Since the level is not read directly, small sensing errors can, over time, cause the gauge to read higher than the actual battery level. The system will then perform a correction, and the battery level gauge reading will drop suddenly. When this happens, IMA assist and Auto Idle Stop are disabled until the IMA battery is sufficiently recharged by normal driving. This should take only a few minutes.

This correction of the battery level gauge is normal and does not indicate a problem. If the IMA battery develops a problem or becomes deteriorated, the IMA system indicator will come on. If this happens, have the vehicle checked by your dealer as soon as possible.

Gauges

Charge/Assist Gauge

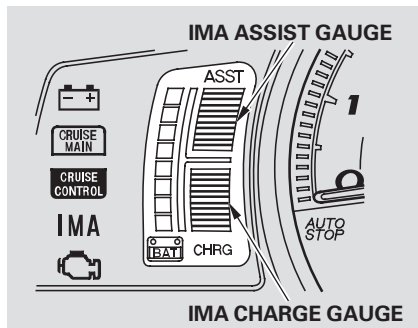

This gauge shows you the status of the Integrated Motor Assist (IMA). When the IMA battery is being charged, the bottom side of the gauge illuminates. When the IMA is assisting the engine, the upper side of the gauge illuminates.

If the IMA battery is too hot or too cold, the IMA system limits the IMA battery's output power to protect the battery. This disables the IMA assist and Auto Idle Stop, even though the Battery Level Gauge may show that the battery is well-charged. Therefore, if the motor assist is frequently used, the battery becomes hot and starts to limit its output power.

It takes the IMA system a few minutes in cold weather to normalize the IMA battery's output power, and about 15 minutes in hot weather.

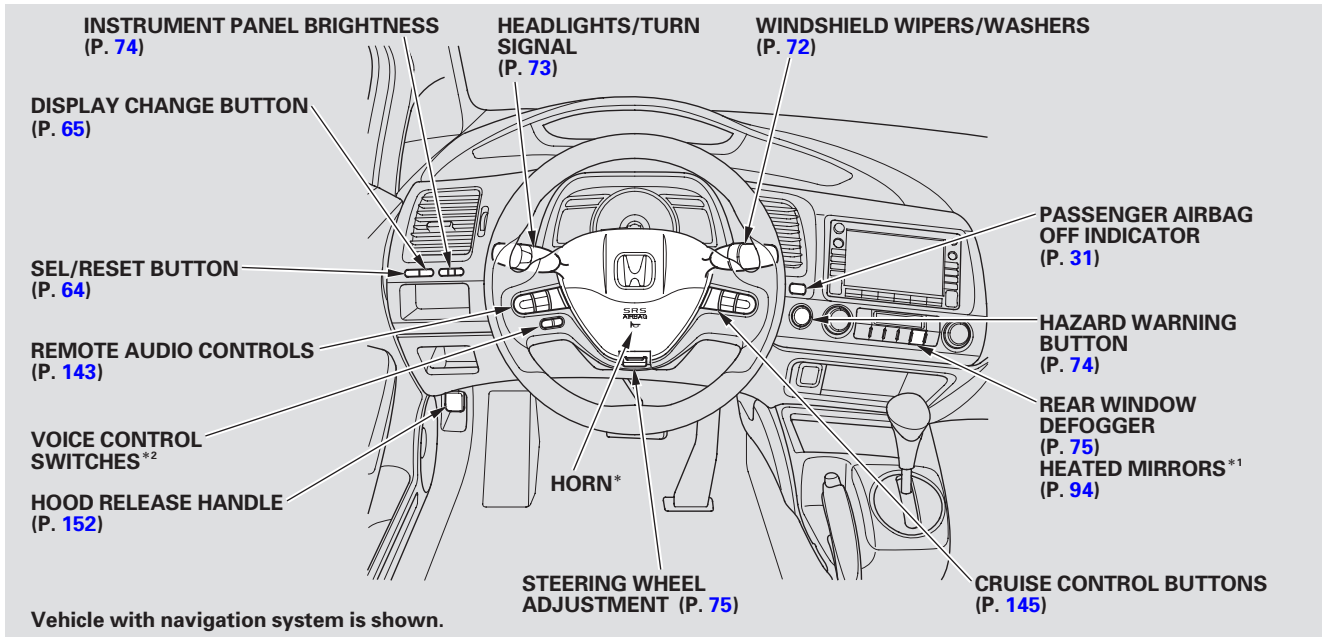

* : To use the horn, press the pad around the “H” logo.

* 1 : Canadian model only

* 2 : Only on vehicles equipped with navigation system. Refer to the navigation system manual.

Windshield Wipers and Washers

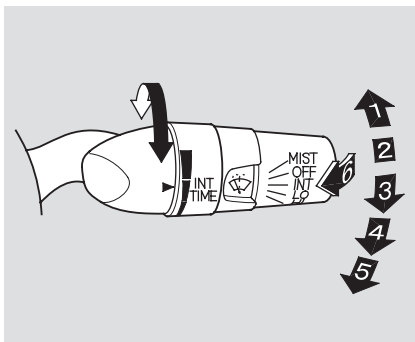

1. MIST
2. OFF
3. INT – Intermittent
4. LO – Low speed
5. HI – High speed
6. Windshield washers

Push the right lever up or down to select a position.

MIST – The wipers run at high speed until you release the lever.

OFF – The wipers are not activated.

INT – The length of the wiper interval is varied automatically according to the vehicle's speed.

Vary the delay by turning the INT TIME ring.

If you turn it to the shortest delay, the wipers will change to low speed operation when the vehicle speed exceeds 12 mph (20 km/h).

While the vehicle is stopped and in gear, the wipers sweep the windshield whenever you remove your foot from the brake pedal.

LO – The wipers run at low speed.

HI – The wipers run at high speed.

Windshield Washers – Pull the wiper control lever toward you, and hold it. The washers spray until you release the lever. The wipers run at low speed, then complete one more sweep after you release the lever.

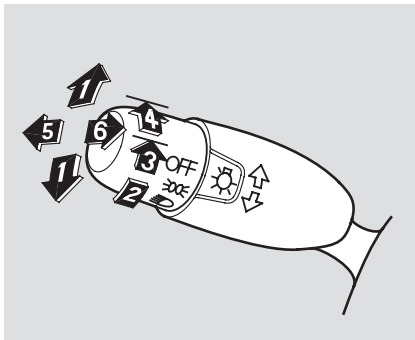



1. Turn signal
2. Off
3. Parking and interior lights
4. Headlights
5. High beams
6. Flash high beams

Turn Signal — Push down on the lever to signal a left turn and up to signal a right turn. To signal a lane change, push lightly on the lever, and hold it. The lever will return to center when you release it or complete a turn.

Headlights — Turning the switch to the “” position turns on the parking lights, taillights, instrument panel lights, side-marker lights, and rear license plate lights.

Turning the switch to the “” position turns on the headlights.

When the light switch is in the “” or “” position, the lights on indicator comes on as a reminder. This indicator stays on if you leave the light switch on and turn the ignition switch to the ACCESSORY (I) or the LOCK (0) position.

If you leave the lights on with the key removed from the ignition switch, you will hear a reminder chime when you open the driver's door.

High Beams — Push the lever forward and the high beam indicator will come on (see page 60). Pull it back to return to low beams.

To flash the high beams, pull the lever back lightly, then release it. The high beams will stay on as long as you hold the lever back.

Headlights, Instrument Panel Brightness, Hazard Warning Button

Daytime Running Lights

With the headlight switch off or $\Rightarrow 0 \Leftarrow$ position, the high beam headlights come on with reduced brightness when you turn the ignition switch to the ON (II) position and release the parking brake. They remain on until you turn the ignition switch off, even if you set the parking brake.

The headlights revert to normal operation when you turn them on with the switch.

Instrument Panel Brightness

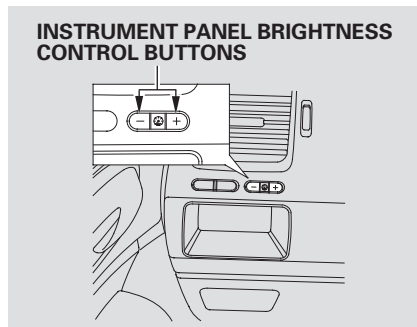

The buttons under the left side vent control the brightness of the instrument panel. Push the + or - button to adjust the brightness.

Separate adjustments can be made when the headlights are on and off.

Hazard Warning Button

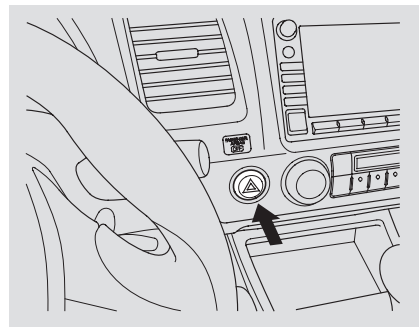

Push the button to turn on the hazard warning lights (four-way flashers). This causes all four outside turn signals and both turn indicators in the instrument panel to flash. Use the hazard warning lights if you need to park in a dangerous area near heavy traffic, or if your vehicle is disabled.

Rear Window Defogger

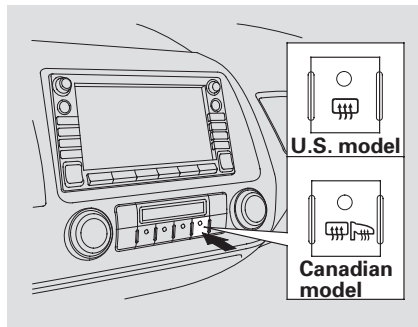

The rear window defogger will clear fog, frost, and thin ice from the window. Push the defogger button to turn it on and off. The indicator in the button comes on to show the defogger is on. If you do not turn it off, the defogger will shut itself off after about 15 minutes. It also shuts off when you turn off the ignition switch. You have to turn the defogger on again when you restart the vehicle.

Make sure the rear window is clear and you have good visibility before starting to drive.

The defogger wires on the inside of the rear window can be accidentally damaged. When cleaning the glass, always wipe side-to-side.

On Canadian models
Pushing this button also turns the mirror heaters on or off. For more information, see page [94](#) .

Steering Wheel Adjustment

Make any steering wheel adjustment before you start driving.

WARNING

Adjusting the steering wheel position while driving may cause you to lose control of the vehicle and be seriously injured in a crash.

Adjust the steering wheel only when the vehicle is stopped.

CONTINUED

Steering Wheel Adjustment, Keys and Locks

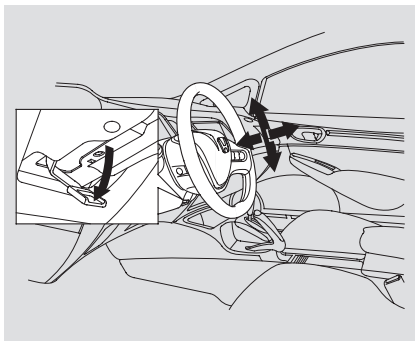

1. Push the lever under the steering column all the way down.
2. Move the steering wheel up or down and in or out to the desired position. Make sure you can see the instrument panel gauges and the indicators.

3. Push the lever up to lock the steering wheel in that position.
4. Make sure you have securely locked the steering wheel in place by trying to move it up, down, in, and out.

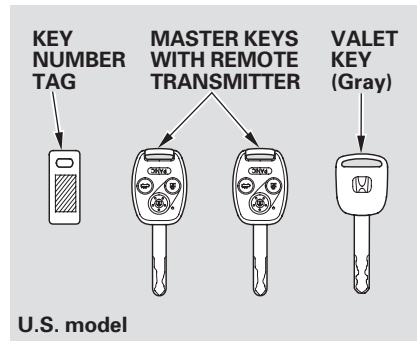

The master key fits all the locks on your vehicle.

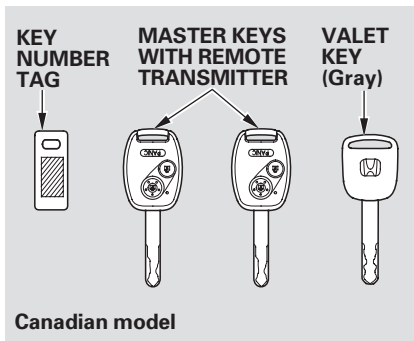

The valet key works only in the ignition and the door locks. You can keep the trunk and trunk release handle locked when you leave your vehicle and the valet key at a parking facility.

You should have received a key number tag with your keys. You will need this key number if you ever have to get a lost key replaced. Use only Honda-approved key blanks.

These keys contain electronic circuits that are activated by the immobilizer system. They will not work to start the engine if the circuits are damaged.

- Protect the keys from direct sunlight, high temperature, and high humidity.
- Do not drop the keys or set heavy objects on them.
- Keep the keys away from liquids. If they get wet, dry them immediately with a soft cloth.

The keys without a remote transmitter do not contain batteries. Do not try to take them apart.

Immobilizer System

The immobilizer system protects your vehicle from theft. If an improperly-coded key (or other device) is used, the engine's fuel system is disabled.

When you turn the ignition switch to the ON (II) position, the immobilizer system indicator should come on briefly, then go off. If the indicator starts to blink, it means the system does not recognize the coding of the key. Turn the ignition switch to the LOCK (0) position, remove the key, reinsert it, and turn the ignition switch to the ON (II) position again.

The system may not recognize your key's coding if another immobilizer key or other metal object (i.e. key fob) is near the ignition switch when you insert the key.

If the system repeatedly does not recognize the coding of your key, contact your dealer.

Do not attempt to alter this system or add other devices to it. Electrical problems could result that may make your vehicle undrivable.

If you have lost your key and cannot start your engine, contact your dealer.

As required by the FCC:

This device complies with Part 15 of the FCC rules. Operation is subject to the following two conditions: (1) This device may not cause harmful interference, and (2) this device must accept any interference received, including interference that may cause undesired operation.

Changes or modifications not expressly approved by the party responsible for compliance could void the user's authority to operate the equipment.

This device complies with Industry Canada Standard RSS-210.

Operation is subject to the following two conditions: (1) this device may not cause interference, and (2) this device must accept any interference that may cause undesired operation of the device.

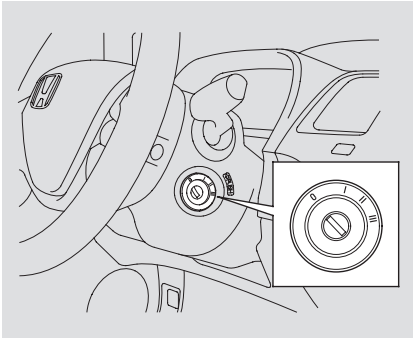

The ignition switch has four positions: LOCK (0), ACCESSORY (I), ON (II), and START (III).

LOCK (0) – You can insert or remove the key only in this position. To turn the key, the shift lever must be in Park, and you must push the key in slightly.

If the front wheels are turned, the anti-theft lock may make it difficult to turn the key. Firmly turn the steering wheel to the left or right as you turn the key.

ACCESSORY (I) – You can operate the audio system and the accessory power sockets in this position.

ON (II) – This is the normal key position when driving. Several of the indicators on the instrument panel come on as a test when you turn the ignition switch from the ACCESSORY (I) to the ON (II) position.

START (III) – Use this position only to start the engine. The switch returns to the ON (II) position when you let go of the key.

You will hear a reminder beeper if you leave the key in the LOCK (0) or the ACCESSORY (I) position and open the driver's door. Remove the key to turn off the beeper.

The shift lever must be in Park before you can remove the key from the ignition switch.

Door Locks

Power Door Locks

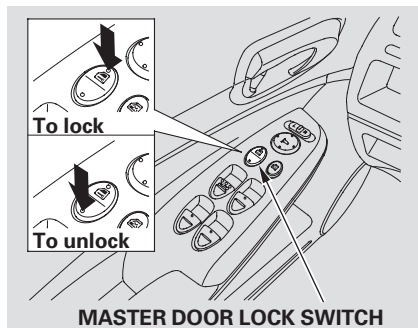

Each front door has a master door lock switch. Either switch locks and unlocks all doors. Push the top of the switch to lock all doors; push the bottom to unlock them.

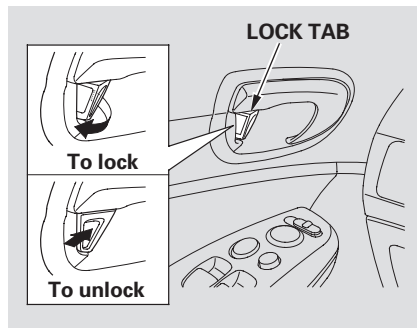

Each door has a lock tab next to the inside door handle. Pull out the tab to lock the door, and push it in to unlock.

The lock tab on each door locks and unlocks that door. Pulling out on the driver's door lock tab locks all doors. To unlock the driver's door from the outside, turn the key and release it. If you turn it again, all the doors unlock.

To lock any door when getting out of the vehicle, pull the lock tab out, and close the door.

To lock the doors when getting out of the vehicle, remove the key from the ignition switch, and push the top of the master door lock switch, then close the door.

Lockout Prevention

With any door open and the key in the ignition, both master door lock switches and driver's door lock tab are disabled. They are not disabled when all the doors are closed, or when the key is not in the ignition.

Childproof Door Locks

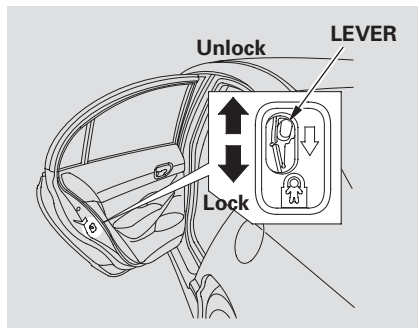

The childproof door locks are designed to prevent children seated in the rear from accidentally opening the rear doors. Each rear door has a lock lever near the edge. With the lever in the LOCK position, the door cannot be opened from the inside regardless of the position of the lock tab. To open the door, push the lock tab in, and use the outside door handle.

Auto Door Locking/Unlocking

Your vehicle has customizable settings for the doors to automatically lock and unlock. Make all settings before you start driving.

Auto Door Locking

The auto door locking feature has three possible settings:

- The doors lock when the vehicle speed reaches 9 mph (15 km/h).
- The auto door locking is deactivated all the time.
- The doors lock whenever you move the shift lever out of the Park position.

To activate an auto door lock mode: Locks all doors when the vehicle's speed reaches about 9 mph (15 km/h).

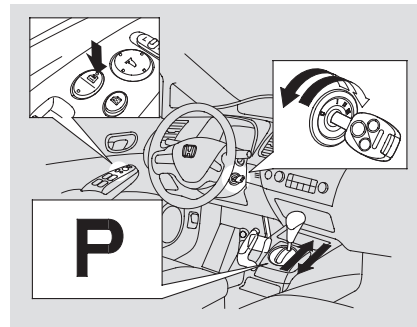

1. Make sure the shift lever is in Park (P), and close the driver's door.
2. Turn the ignition switch to the ON (II) position.
3. Set the parking brake.

Door Locks

4. Push and hold the brake pedal, then move the shift lever out of Park (P).
5. Push and hold the lock side of the master door lock switch on the driver's door. You will hear a clicking sound, and after about 5 seconds, you will hear another clicking sound.
6. Release the switch, turn the ignition switch to the ACCESSORY (I) position within 5 seconds and move the shift lever to Park (P).

To turn off the auto door lock modes:

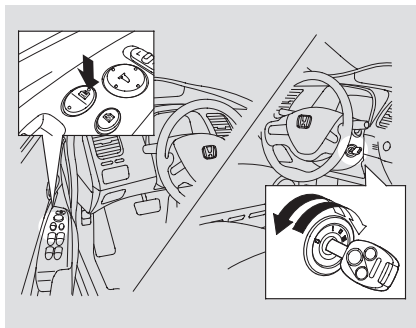

1. Make sure the shift lever is in Park (P), and open the driver's door.
2. Turn the ignition switch to the ON (II) position.
3. Set the parking brake.

4. Push and hold the lock side of the master door lock switch on the driver's door. You will hear a clicking sound after about 5 seconds.
5. Release the switch, and turn the ignition switch to the ACCESSORY (I) position within 5 seconds.

To activate an auto door lock mode:
Locks all doors when the shift lever is moved out of Park (P).

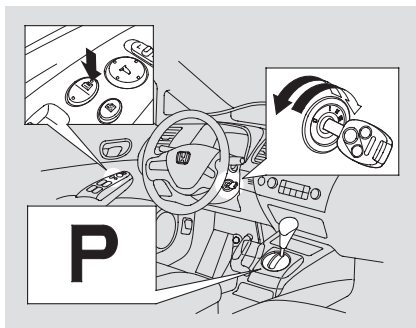

1. Make sure the shift lever is in Park (P), and close the driver's door.
2. Turn the ignition switch to the ON (II) position.

3. Push and hold the lock side of the master door lock switch on the driver's door. You will hear a clicking sound, and after about 5 seconds, you will hear another clicking sound.
4. Release the switch, and turn the ignition switch to the ACCESSORY (I) position within 5 seconds.

Auto Door Unlocking

The auto door unlocking feature has five possible settings:

- The driver's door unlocks whenever you turn the ignition switch to the ACCESSORY (I) position.
- The auto door unlocking is deactivated all the time.
- The driver's door unlocks when you move the shift lever to the Park position.
- All doors unlock when you move the shift lever to the Park position.
- All doors unlock whenever you turn the ignition switch to the ACCESSORY (I) position.

Door Locks

To activate an auto door unlock mode:

Unlocks driver's door or all doors when the ignition switch is out of the ON (II) position.

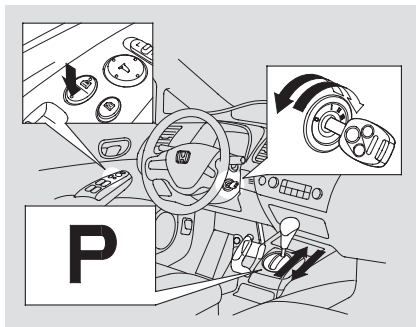

1. Make sure the shift lever is in Park (P), and close the driver's door.
2. Turn the ignition switch to the ON (II) position.
3. Set the parking brake.

4. Push and hold the brake pedal, then move the shift lever out of Park (P).
5. Push and hold the unlock side of the master door lock switch on the driver's door. You will hear a clicking sound, and after about 5 seconds, you will hear another clicking sound.

- Until you hear one click (after about 5 seconds) to activate the driver's door unlock feature.
- Or, until you hear a second click (after about 10 seconds) to activate the all doors unlock feature.

6. Release the switch, turn the ignition switch to the ACCESSORY (I) position within 5 seconds and move the shift lever to Park (P).

To turn off the auto door lock modes:

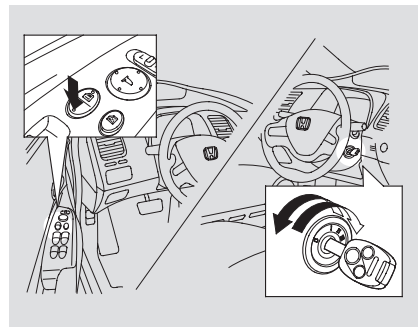

1. Make sure the shift lever is in Park (P), and open the driver's door.
2. Turn the ignition switch to the ON (II) position.
3. Set the parking brake.

4. Push and hold the unlock side of the master door lock switch on the driver's door. You will hear a clicking sound, and after about 5 seconds, you will hear another clicking sound.
5. Release the switch, and turn the ignition switch to the ACCESSORY (I) position within 5 seconds.

To activate an auto door unlock mode:

Unlocks driver's door or all doors when the shift lever is moved to Park (P).

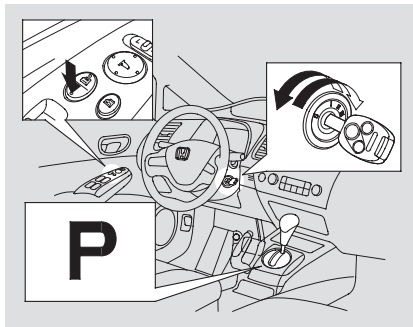

1. Make sure the shift lever is in Park (P), and close the driver's door.
2. Turn the ignition switch to the ON (II) position.

3. Push and hold the unlock side of the master door lock switch on the driver's door. You will hear a clicking sound, and after about 5 seconds, you will hear another clicking sound.
 - Until you hear one click (after about 5 seconds) to activate the driver's door unlock feature.
 - Or, until you hear a second click (after about 10 seconds) to activate the all doors unlock feature.
4. Release the switch, and turn the ignition switch to the ACCESSORY (I) position within 5 seconds.

Trunk

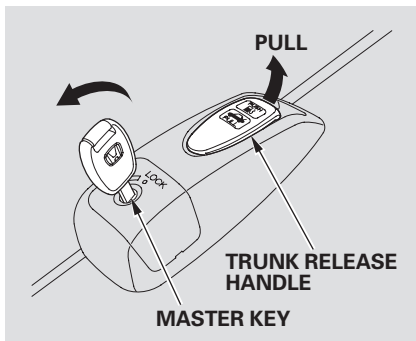

To open the trunk, pull the trunk release handle on the left side of the driver's seat. To protect items in the trunk when you need to give the key to someone else, lock the trunk release handle with the master key, and give the other person the valet key.

U.S. model only

Press and hold the trunk release button on the remote transmitter.



You can also use the master key to open the trunk lock.

To close the trunk, press down on the trunk lid.

Keep the trunk lid closed at all times while driving to avoid damaging it, and to prevent exhaust gas from getting into the interior. See **Carbon Monoxide Hazard**, page [52](#).

Emergency Trunk Opener

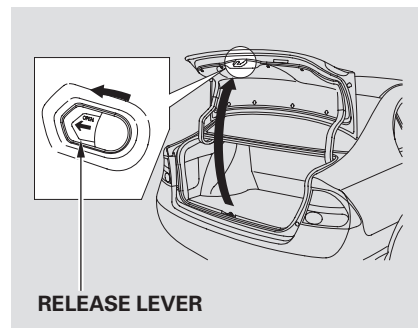

As a safety feature, your vehicle has a release lever on the trunk latch so the trunk can be opened from the inside. To open the trunk, push the release lever to the left.

Parents should decide if their children should be shown how to use this feature. For more information about child safety, see page [38](#).

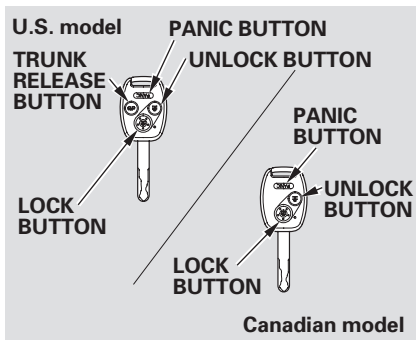

LOCK — Press this button once to lock all doors. Some exterior lights will flash once. When you push LOCK twice within 5 seconds, you will hear a horn to verify that the doors are locked. You cannot lock the doors if any door is not fully closed or the key is in the ignition switch.

If you push the LOCK button twice within 5 seconds, you will hear a horn to verify that the security system has set.

UNLOCK — Press this button once to unlock the driver's door. Push it twice to unlock the other doors. Some exterior lights will flash twice each time you press the button. This button does not work when the key is in the ignition switch.

The ceiling light (if the ceiling light switch is in the door activated position) will come on when you press the UNLOCK button. If you do not open any door, the light stays on for about 30 seconds, then fades out. If you relock the doors with the remote transmitter before 30 seconds have elapsed, the light goes off immediately.

If you unlock the doors with the remote transmitter, but do not open any of the doors within 30 seconds, the doors automatically relock and the security system will also set.

PANIC — Press this button for about 1 second to attract attention; the horn will sound and the exterior lights will flash for about 30 seconds. To cancel panic mode, press any other button on the remote transmitter, or turn the ignition switch to the ON (II) position.

On U.S. model

TRUNK RELEASE — Press this button for about 1 second to open the trunk. You cannot open the trunk if the key is in the ignition switch.

Remote Transmitter Care

- Avoid dropping or throwing the transmitter.
- Protect the transmitter from extreme temperature.
- Do not immerse the transmitter in any liquid.
- If you lose a transmitter, the replacement needs to be reprogrammed by your dealer.

Remote Transmitter

Replacing the Transmitter Battery

If it takes several pushes on the button to lock or unlock the doors, replace the battery as soon as possible.

Battery type: CR1616

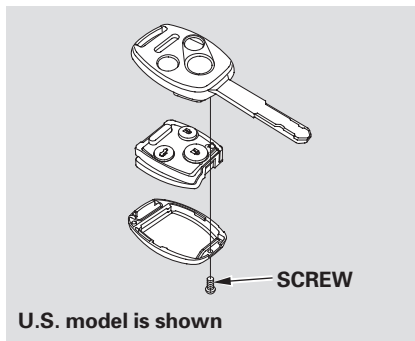

To replace the battery:

1. Remove the screw at the base of the transmitter with a small Phillips-head screwdriver.
2. Separate the transmitter by prying its middle seam with your fingernail.

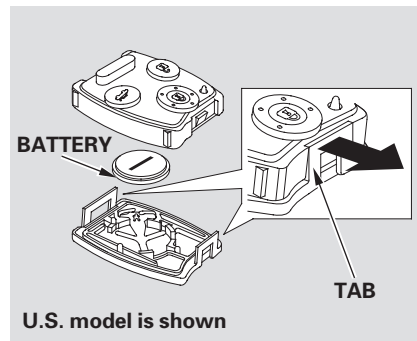

3. Inside the transmitter, separate the inner cover from the keypad by releasing the two tabs on the cover.

4. Remove the old battery from the back of the inner cover, and note the polarity. Make sure the polarity of the new battery is the same (+ side facing down), then insert it into the back of the cover.

An improperly disposed of battery can hurt the environment. Always confirm local regulations for battery disposal.

5. Install the parts in reverse order.

As required by the FCC:

This device complies with Part 15 of the FCC rules. Operation is subject to the following two conditions: (1) This device may not cause harmful interference, and (2) this device must accept any interference received, including interference that may cause undesired operation.

Changes or modifications not expressly approved by the party responsible for compliance could void the user's authority to operate the equipment.

This device complies with Industry Canada Standard RSS-210.

Operation is subject to the following two conditions: (1) this device may not cause interference, and (2) this device must accept any interference that may cause undesired operation of the device.

Front Seat Adjustments

See pages 11 – 13 for important safety information and warnings about how to properly position seats and seat-backs. Make all adjustments before you start driving.

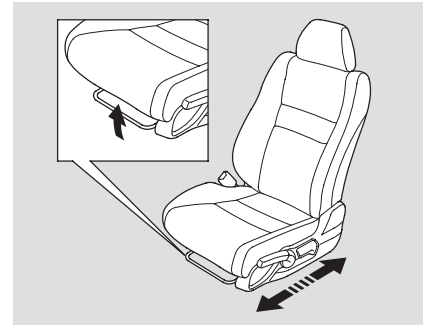

To adjust the seat forward or backward, pull up on the bar under the seat cushion's front edge. Move the seat to the desired position, and release the bar. Try to move the seat to make sure it is locked in position.

CONTINUED

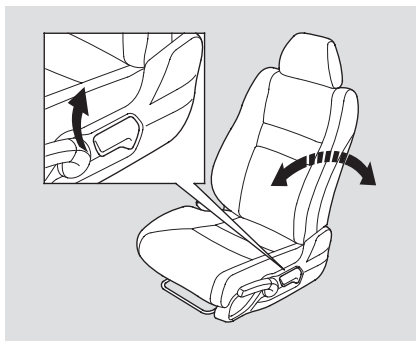

To change the seat-back angle of the front seat, pull up the lever on the outside of the seat bottom.

Once a seat is adjusted correctly, rock it back and forth to make sure it is locked in position.

Driver's Seat Height Adjustment

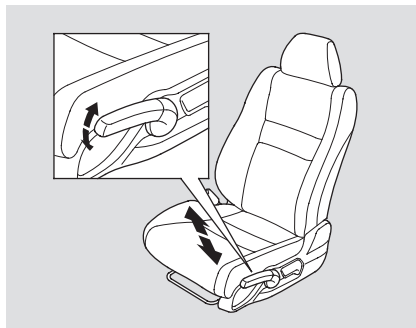

The height of your driver's seat is adjustable. To raise the seat, repeatedly pull up the lever on the outside of the seat cushion. To lower the seat, push the lever down repeatedly.

Head Restraints

See page 13 for important safety information and a warning about how to properly position the head restraints.

Your vehicle is equipped with head restraints in all seating positions to help protect you and your passengers from whiplash and other injuries.

They are most effective when you adjust them so the back of the occupant's head rests against the center of the restraint.

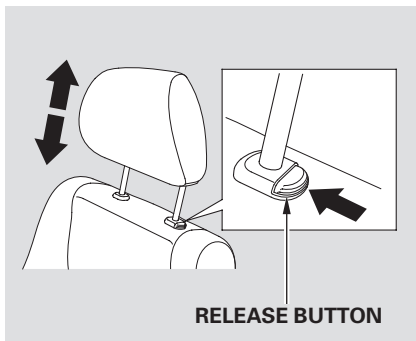

The head restraints adjust for height. You need both hands to adjust a restraint. Do not attempt to adjust it while driving. To raise it, pull upward. To lower the restraint, push the release button sideways, and push the restraint down.

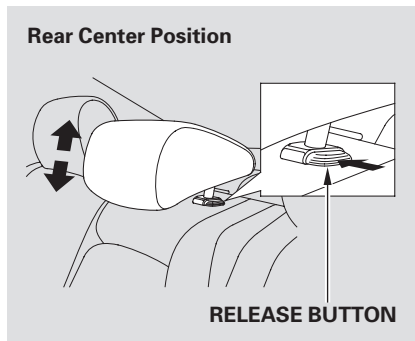

When a passenger is seated in the rear center seating position, make sure the center head restraint is adjusted to its highest position.

Armrest

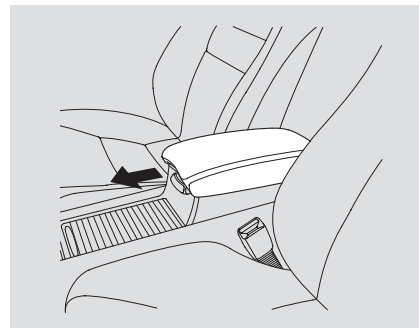

The lid of the console compartment can be used as an armrest by moving it forward and backward. Make sure the armrest is securely latched.

Make sure your passenger's hands or fingers are away from the armrest before moving it.

Power Windows

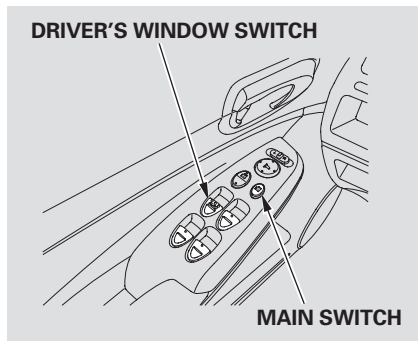

Turn the ignition switch to the ON (II) position to raise or lower any window. To open the window, push the switch down and hold it. Release the switch when you want to stop the window. To close the window, pull back on the switch and hold it.

The windows operate for up to 10 minutes after you turn off the ignition switch. Opening either front door cancels this function.

⚠ WARNING

Closing a power window on someone's hands or fingers can cause serious injury.

Make sure your passengers are away from the windows before closing them.

If the MAIN switch is OFF, the passenger windows cannot be raised or lowered. Keep the MAIN switch off when you have children in the vehicle so they do not injure themselves by operating the windows unintentionally.

AUTO — To open or close the driver's window, push or pull the window switch firmly down or up to the second detent, and release it. The window will automatically go down or up all the way. To stop the window, pull or push the window switch briefly.

AUTO REVERSE — If the driver's window senses any obstacle while it is closing automatically, it will reverse direction, and then stop. To close the window, remove the obstacle, then use the window switch again.

Auto reverse stops sensing when the window is almost closed. You should always check that all passengers and objects are away from the window before closing it.

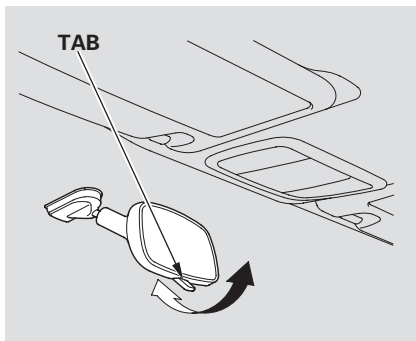

Keep the inside and outside mirrors clean and adjusted for best visibility. Be sure to adjust the mirrors before you start driving.

The inside mirror has day and night positions. The night position reduces glare from headlights behind you. Flip the tab on the bottom edge of the mirror to select the day or night position.

Adjusting the Power Mirrors

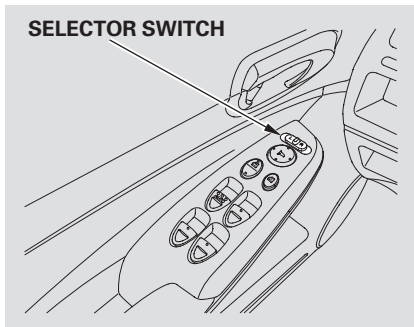

1. Turn the ignition switch to the ON (II) position.
2. Move the selector switch to L (driver's side) or R (passenger's side).

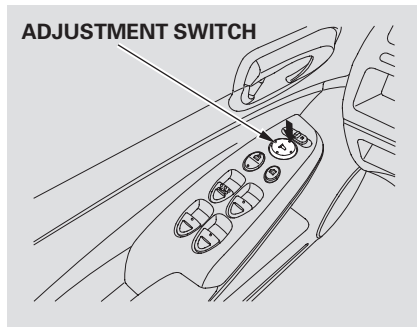

3. Push the appropriate edge of the adjustment switch to move the mirror right, left, up, or down.
4. When you finish, move the selector switch to the center (off) position. This turns the adjustment switch off to keep your settings.

Mirrors, Parking Brake

Heated Mirrors

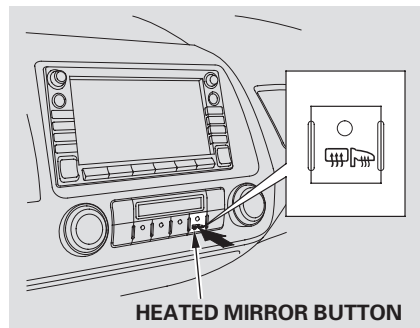

On Canadian models
The outside mirrors are heated to remove fog and frost. With the ignition switch in the ON (II) position, turn on the heaters by pressing the button. The indicator in the button comes on as a reminder. Press the button again to turn the heaters off. Pressing this button also turns the rear window defogger on and off.

Parking Brake

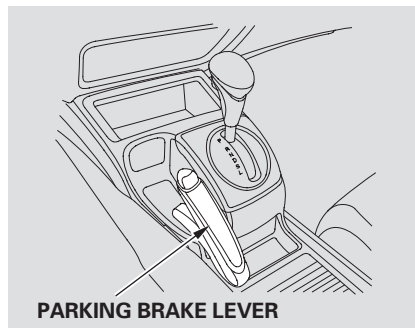

To apply the parking brake, pull the lever up fully. To release it, pull up slightly, push the button, and lower the lever. The parking brake indicator on the instrument panel should go out when the parking brake is fully released (see page [58](#)).

NOTICE

Driving the vehicle with the parking brake applied can damage the rear brakes and axles. A beeper will sound if the vehicle is driven with the parking brake on.

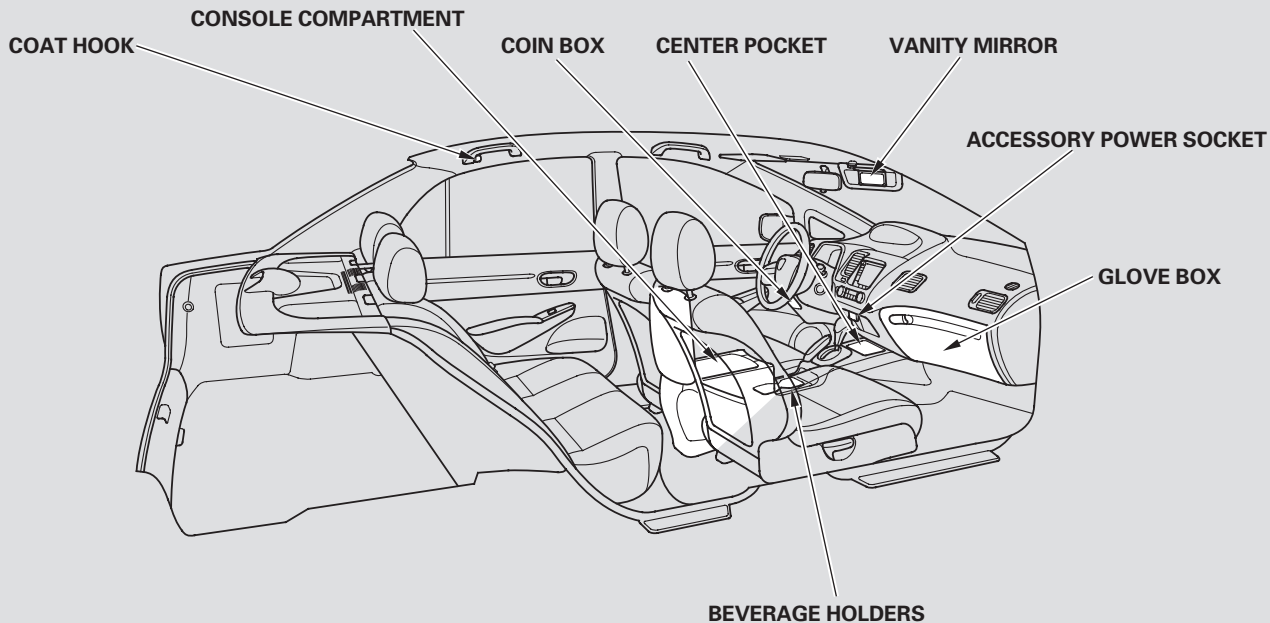

Interior Convenience Items

Beverage Holders

Be careful when you are using the beverage holders. A spilled liquid that is very hot can scald you or your passengers. Spilled liquids can damage the upholstery, carpeting, and electrical components in the interior.

Open the front beverage holder by sliding its cover backward.

Accessory Power Socket

This socket is intended to supply power for 12 volt DC accessories that are rated 120 watts or less (10 amps). It will not power an automotive type cigarette lighter element.

To use an accessory power socket, the ignition switch must be in the ACCESSORY (I) or ON (II) position.

Another accessory power socket is in the center console compartment. When more than one socket is being used, the combined power rating of the accessories should be 120 watts or less (10 amps).

Glove Box

Open the glove box by pulling the handle to the left. Close it with a firm push.

⚠ WARNING

An open glove box can cause serious injury to your passenger in a crash, even if the passenger is wearing the seat belt.

Always keep the glove box closed while driving.

Console Compartment

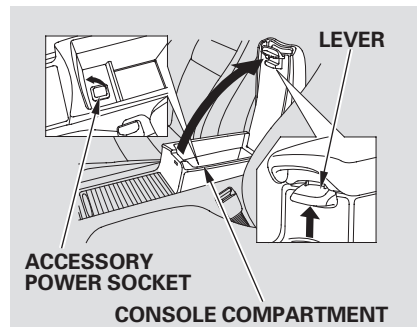

To open the console compartment, pull up on the lever, and lift the lid.

To close, lower the lid, and push it down until it latches.

Ceiling Light

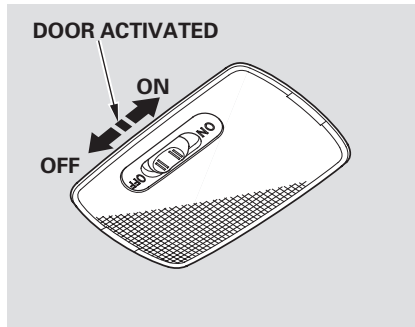

The ceiling light has a three-position switch; ON, Door Activated, and OFF. In the Door Activated (center) position, the light comes on when you:

- Open any door.
- Unlock the doors with the key or remote transmitter.
- Remove the key from the ignition.

After all doors are closed tightly, the light dims slightly, then fades out in about 30 seconds.

If you do not open either door after you unlock the driver's door or remove the key from the ignition switch, the light fades out in about 30 seconds.

If you leave either door open without the key in the ignition switch, the ceiling light will go off after 3 minutes.

Spotlights

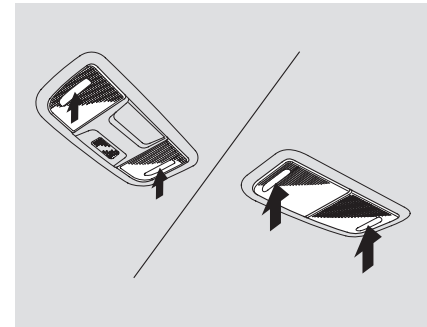

The front ceiling light has two spotlights. Push the spotlight lenses to turn them on and off.

The heating and air conditioning system in your vehicle provides a comfortable driving environment in all weather conditions.

The standard audio system has many features. This section describes those features and how to use them. (If you have an optional audio system, refer to the operating instructions that came with it.)

Your vehicle has an anti-theft audio system that requires a code number to enable it.

The security system helps to discourage vandalism and theft of your vehicle.

Climate Control.....	100
Audio System	106
Playing the Radio	109
Playing a Disc.....	112
Disc Player Error Messages	118
Setting the Clock	119
Playing the Radio (Vehicles with Navigation System)	121
Playing a Disc (Vehicles with Navigation System)	125
Playing a PC Card (Vehicles with Navigation System)	129
Disc Player Error Messages (Vehicles with Navigation System)	138
Radio Reception	139
Protecting Your Discs.....	141
Radio Theft Protection.....	142
Remote Audio Controls.....	143
Security System	144
Cruise Control.....	145

Climate Control

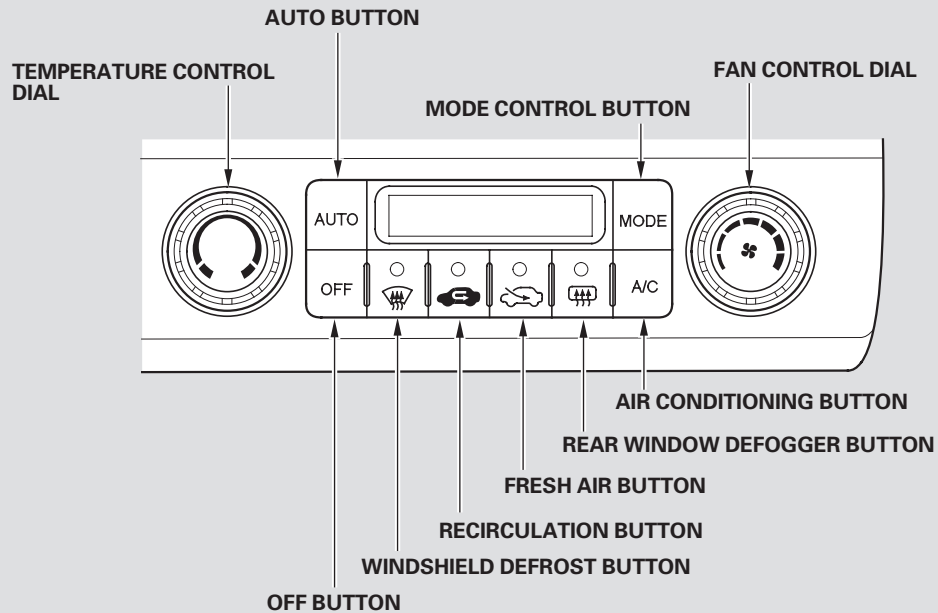

Voice Control System

Only on models equipped with Navigation System

The climate control system for your vehicle can also be operated using the voice control system. See the Navigation section in your Quick Start Guide for an overview of this system and the Navigation System manual for complete details.

Using Automatic Climate Control

The automatic climate control system adjusts the fan speed and airflow levels to maintain the interior temperature you select.

- Press the AUTO button.
- Set the desired temperature by turning the temperature control dial. You will see AUTO in the system's display.

The system automatically selects the proper mix of conditioned and/or heated air that will, as quickly as possible, raise or lower the interior temperature to your preference.

When you set the temperature to its lower limit (**Lo**) or its upper limit (**Hi**), the system runs at full cooling or heating only. It does not regulate the interior temperature.

In cold weather, the fan will not come on automatically until the heater starts to develop warm air.

In "AUTO" mode, the air conditioner may not work if the humidity inside the vehicle is low. To activate the air conditioner, press A/C button.

Semi-automatic Operation

You can manually select various functions of the climate control system when it is in full automatic mode. All other features remain automatically controlled.

Making any manual selection causes the word AUTO in the display to go out.

Fan Control Dial

Turn this dial to increase or decrease the fan speed and airflow.

Temperature Control Dial

Turning this dial clockwise increases the temperature of the airflow.

Climate Control

Air Conditioning (A/C) Button

This button turns the air conditioning on and off. The indicator in the button is on when the A/C is on.

Recirculation Button

When the recirculation indicator is on, air from the vehicle's interior is sent throughout the system again. To select recirculation mode when driving through dusty or smoky conditions, then return to fresh air mode.

Fresh Air Button

The outside air intakes for the heating and cooling system are at the base of the windshield. Keep this area clear of leaves and other debris.

When the fresh air indicator is on, air is brought in from the outside of the vehicle.



The system should be left in fresh air mode under almost all conditions. Keeping the system in recirculation mode, particularly with the A/C off, can cause the windows to fog up.

Mode Control Button

Use the mode control buttons to select the vents air flows from. Some air will flow from the dashboard corner vents in all modes.

 Air flows from the center and corner vents in the dashboard.

 Airflow is divided between the vents in the dashboard and the floor vents.

 Air flows from the floor vents. When you select  , the system automatically switches to fresh air mode.

 Airflow is divided between the floor vents and defroster vents at the base of the windshield.

 Air flows from the defroster vents at the base of the windshield.

When you select  , the system automatically switches to fresh air mode and turns on the A/C.

In AUTO mode, the system controls the airflow direction automatically between the dashboard vents and the floor vents.



Ventilation

The flow-through ventilation system draws in outside air, circulates it through the interior, then exhausts it through vents near the rear side panels.

1. Set the temperature to the lower limit.
2. Make sure the A/C is off.
3. Select  and fresh air mode.
4. Set the fan to the desired speed.

Using the Heater

The heater uses engine coolant to warm the air. If the engine is cold, it will be several minutes before you feel warm air coming from the system.

1. Select  .
When you select  , the system automatically switches to the fresh air mode.
2. Set the fan to the desired speed.
3. Adjust the warmth of the air with the temperature control dial.

Using the A/C

Air conditioning places an extra load on the engine. Watch the engine coolant temperature gauge (see page 65). If it moves near the red zone, turn off the A/C until the gauge reading returns to normal.

1. Turn on the A/C by pressing the button. The indicator in the button comes on when a fan speed is selected.
2. Make sure the temperature is set to maximum cool.
3. Select  .
4. If the outside air is humid, select recirculation mode. If the outside air is dry, select fresh air mode.
5. Set the fan to the desired speed.

If the interior is very warm, you can cool it down more rapidly by partially opening the windows, turning on the A/C, and setting the fan to maximum speed in fresh air mode.

Dehumidify the Interior



Air conditioning, as it cools, removes moisture from the air. When used in combination with the heater, it makes the interior warm and dry and can prevent the windows from fogging up.

1. Turn the fan on.
2. Turn on the air conditioning.
3. Select  and fresh air mode.
4. Adjust the temperature to your preference.



This setting is suitable for all driving conditions whenever the outside temperature is above 32°F (0°C).

To Defog and Defrost

To remove fog from the inside of the windows:

1. Set the fan to the desired speed, or high for faster defrosting.
2. Select . When you select , the system automatically switches to fresh air mode and turns on the A/C. The A/C indicator will not come on, if it was previously off.
3. Adjust the temperature so the airflow feels warm.
4. Select  to help clear the rear window.
5. To increase airflow to the windshield, close the corner vents.

To Remove Exterior Frost or Ice From the Windows

1. Select . When you select , the system automatically switches to fresh air mode and turns on the A/C. The A/C indicator will not come on, if it was previously off.
2. Select .
3. Set the fan and temperature controls to maximum level.

To clear the windows faster, you can close the dashboard corner vents by rotating the wheel below each vent. This sends more warm air to the windshield defroster vents. Once the windshield is clear, select fresh air mode to avoid fogging the windows.

For your safety, make sure you have a clear view through all the windows before driving.

To Turn Everything Off

Press the OFF button. However, a lack of airflow can cause the windows to fog up. You should keep the fan on at all times so stale air and moisture do not build up in the interior and cause fogging.

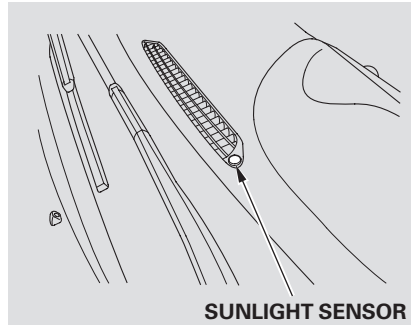
Sunlight, Temperature, and Humidity Sensors

To regulate the interior temperature and humidity, the climate control system has two sensors. A sunlight sensor is located in the top of the dashboard and a temperature/humidity sensor is next to the steering column. Do not cover the sensors or, spill liquid or spray chemical cleaners on the sensors.

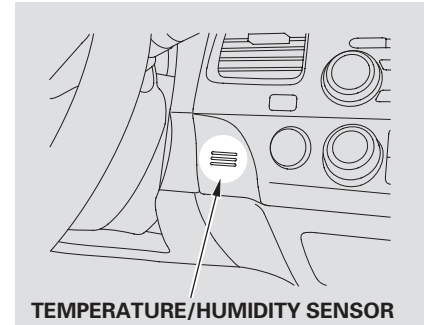

Audio System

Read the appropriate pages in this section for operation of the audio systems installed in your vehicle.

- page 108 to 120 for A and B type
- page 121 to 138 for C type

If your vehicle has a different audio system, refer to its manual for operating instructions.

(A type) Canadian model

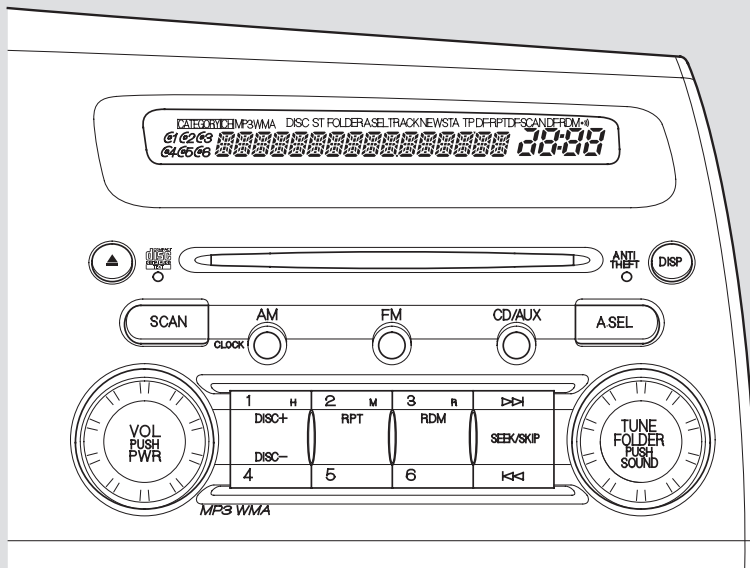

(B type)

U.S. model without navigation system

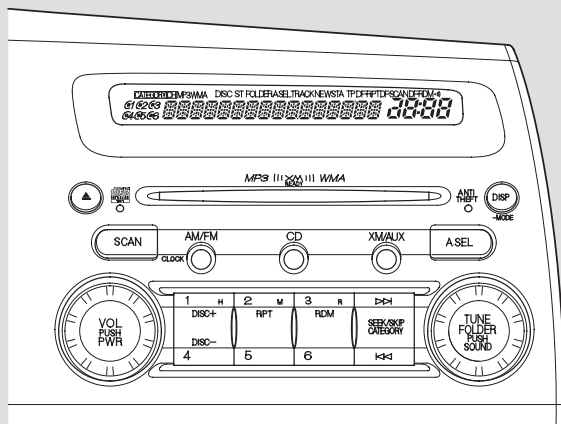

(C type)

U.S. model with navigation system

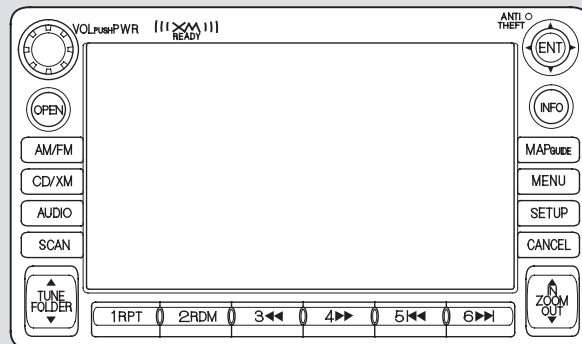

Playing the Radio

(A type)

Canadian model

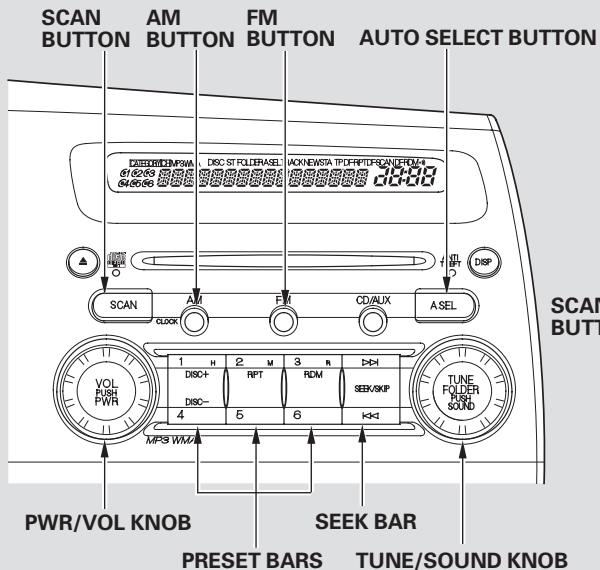

(B type)

U.S. model without navigation system

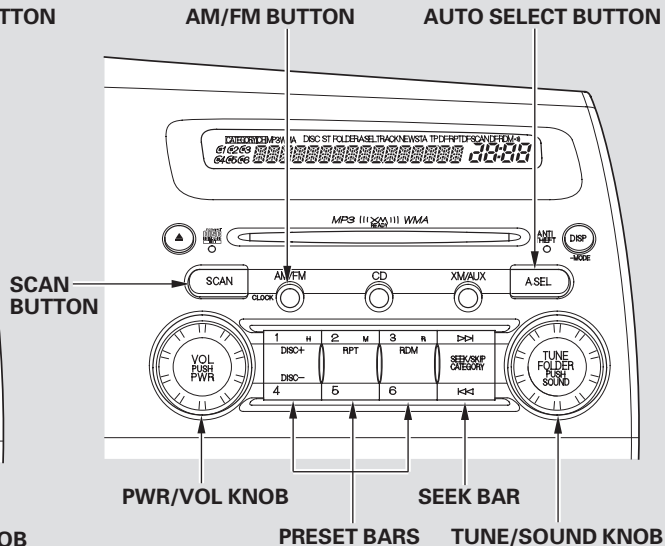

To Play the Radio

The ignition switch must be in the ACCESSORY (I) or ON (II) position. Turn the system on by pushing the PWR/VOL knob. Adjust the volume by turning the same knob.

The band and frequency that the radio was last tuned to is displayed. To change bands, press the AM/FM button (AM or FM button). On the FM band, ST will be displayed if the station is broadcasting in stereo. Stereo reproduction in AM is not available.

To Select a Station

You can use any of five methods to find radio stations on the selected band: TUNE, SEEK, SCAN, the preset bars, and AUTO SELECT.

TUNE — Use the TUNE knob to tune the radio to a desired frequency. Turn the knob right to tune to a higher frequency, or left to tune to a lower frequency.

SEEK — The seek function searches up and down from the current frequency to find a station with a strong signal. To activate it, press the ◀◀ or ▶▶ side of the SEEK bar, then release it.

SCAN — The scan function samples all stations with strong signals on the selected band. To activate it, press the SCAN button, then release it. You will see SCAN in the display. The system will scan for a station with a strong signal. When it finds one, it will stop and play that station for about 10 seconds.

If you do nothing, the system will then scan for the next strong station and play it for 10 seconds. When it plays a station you want to listen to, press the SCAN button again.

PRESET — Each side of the bars (1–6) can store one station on AM, and two stations on FM.

1. Select the desired band, AM or FM. FM1 and FM2 let you store twelve stations.
2. Use the tune, seek, or scan function to tune the radio to a desired station.
3. Pick a preset number (1–6), and hold it until you hear a beep.
4. Repeat steps 1 through 3 to store a total of six stations on AM and twelve stations on FM.

CONTINUED

Playing the Radio

AUTO SELECT — If you are traveling far from home and can no longer receive your preset stations, you can use the auto select feature to find stations in the local area.

Press the A. SEL button. “A.SEL” flashes in the display, and the system goes into scan mode for several seconds. It stores the frequencies of six AM, and twelve FM stations in the preset bars.

You will see a “0” displayed after pressing a preset bar if auto select cannot find a strong station for every preset bar.

If you do not like the stations auto select has stored, you can store other frequencies on the preset bars as previously described.

To turn off auto select, press the A. SEL (auto select) button. This restores the presets you originally set.

Adjusting the Sound

Press the SOUND (TUNE) knob repeatedly to display the bass (BAS), treble (TRE), fader (FAD), balance (BAL), and speed-sensitive volume compensation (SVC) settings.

Each mode is shown in the display as it changes. Turn the SOUND (TUNE) knob to adjust the setting to your liking. When the level reaches the center, you will see “ [” in the display. The system will automatically return the display to the selected audio mode about 5 seconds after you stop adjusting a mode.

Treble/Bass — Use the TREBLE/BASS modes to adjust the tone to your liking.

Balance/Fader — These two modes adjust the strength of the sound coming from each speaker. BALANCE adjusts the side-to-side strength, while FADER adjusts the front-to-back strength.

Speed-sensitive volume compensation (SVC) — The SVC mode controls the volume based on vehicle speed. The faster you go, the louder the audio volume becomes. As you slow down, the audio volume decreases.

The SVC has four modes; SVC OFF, SVC LOW, SVC MID, and SVC HIGH. The default setting is MID. Turn the SOUND (TUNE) knob to adjust the setting to your liking. If you feel the sound is too loud, choose low. If you feel the sound is too quiet, choose high.

Audio System Lighting

You can use the instrument panel brightness control buttons to adjust the illumination of the audio system (see page 74). The audio system illuminates when the parking lights are on, even if the radio is off.

Playing a Disc

(A type)

Canadian model

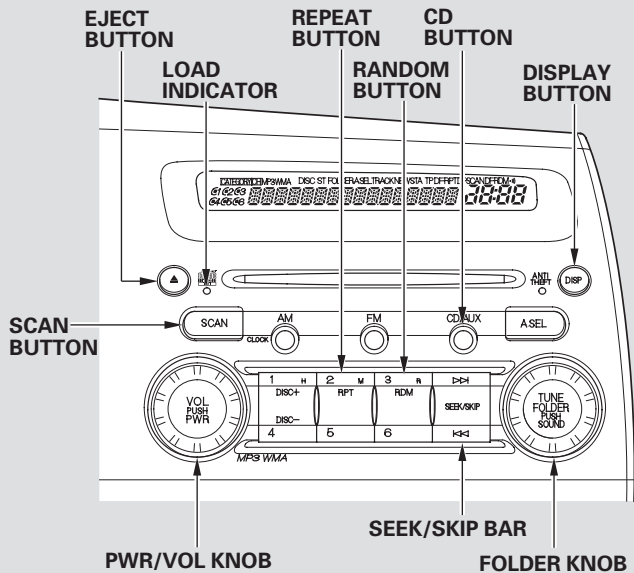

(B type)

U.S. model without navigation system

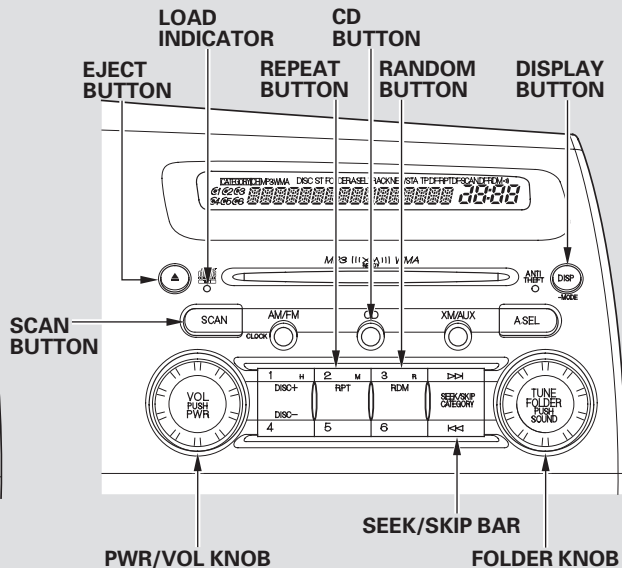

To Play a Disc

To load or play discs, the ignition switch must be in the ACCESSORY (I) or ON (II) position.

You operate the CD player with the same controls used for the radio. To select the CD player, press the CD button. You will see “CD” in the display. The number of the track playing is shown in the display. The system will continuously play a disc until you change modes.

The disc player can also play CD-Rs and CD-RWs compressed in CD-TEXT, MP3, and WMA formats. When playing a disc in MP3 or WMA, you will see “MP3” or “WMA” in the display. You can select up to 255 folders or tracks.

Video CDs and DVDs will not work in this unit.

The specifications of the compatible MP3 file are:

Sampling frequency: 32/44.1/48 kHz
(MPEG1), 24, 22.05, 16 kHz
(MPEG2)

Bit rate: 32/40/48/56/64/80/96/
112/128/160/192/224/256/320 kbps
(MPEG1), 8/16/24/32/40/48/56/
64/80/96/112/128/160 kbps
(MPEG2)

Compatible with variable bit rate and multi-session.

Maximum layers
(including ROOT): 8 layers

The specifications of the compatible WMA file are:

Sampling frequency: 32/44.1/48 kHz
Bit rate: 48/64/80/96/128/160/192
kbps

Compatible with variable bit rate and multi-session.

Maximum layers (including ROOT):
8 layers

Insert the disc about halfway into the disc slot. The drive will pull the disc in the rest of the way and begin to play it. When the system reaches the end of the disc, it will return to the beginning and play the disc again.

You can also play 3-inch (8-cm) discs without using an adapter ring.

To play the radio when a disc is playing, press the AM/FM button (AM or FM button). Press the CD button again to switch back to the CD player.

NOTICE

Do not use discs with adhesive labels. The label can curl up and cause the disc to jam in the unit.

CONTINUED

Name Display Function

Each time you press the DISP button while playing a CD-TEXT, the display mode changes from album name, to artist name, to track name, and then to normal display. When playing a disc in MP3/WMA, the display mode changes from folder name, to file name, to artist tag, to album tag, to track tag, and then to normal display.

If the title is too long, it will not show all at once. Press and hold the DISP button, and the rest of the title will show in the display.

You will also see the album and track name (CD-TEXT), or the folder and file name (MP3/WMA) under these conditions:

- When you insert a disc, and the system begins to play.
- Each time a new track, file, or folder plays, other than in normal display mode.

To Change or Select Tracks/Files

You can use the SEEK/SKIP bar while a disc is playing to select passages and change tracks (files in MP3/WMA mode).

In MP3/WMA mode, use the FOLDER (TUNE) knob to select folders in the disc, and use the SEEK/SKIP bar to change files.

SEEK/SKIP — Each time you press and release the ►►| side, the player skips forward to the beginning of the next track (files in MP3/WMA mode). Press and release the |◄◄ side to skip backward to the beginning of the current track. Press it again to skip to the beginning of the previous track.

To move rapidly within a track, press and hold the ►►| or |◄◄ side of the SEEK/SKIP bar.

In MP3/WMA mode

FOLDER SELECTION — To select a different folder, turn the FOLDER (TUNE) knob clockwise to move to the beginning of the next folder. Turn the knob counterclockwise to move to the beginning of the current folder. Turn it counterclockwise again to skip to the beginning of the previous folder.

REPEAT (TRACK/FILE REPEAT) — To continuously replay a track (file in MP3/WMA mode), press and release the RPT button. You will see RPT in the display. Press and hold the RPT button to turn it off.

CONTINUED

Playing a Disc

In MP3/WMA mode

FOLDER-REPEAT — This feature, when activated, replays all the files on the selected folder in the order they are compressed in MP3/WMA. To activate folder repeat mode, press the RPT button repeatedly until you see F-RPT in the display. The system continuously replays the current folder. Press and hold the RPT button to turn it off.

Each time you press and release the RPT button, the mode changes from file repeat to folder repeat, then to normal playing.

RANDOM (Random within a Disc) — This feature plays the track within a disc in random order. In MP3/WMA mode, this feature only plays folders within a disc in random order. Files in the folder are played in recorded order. To activate random play, press and release the RDM button. In MP3/WMA mode, press the RDM button twice to select within a disc random play. You will see RDM in the display. Press and release the RDM button again to return to normal play.

In MP3/WMA mode

FOLDER-RANDOM — This feature, when activated, plays the files in the current folder in random order, rather than in the order they are compressed in MP3/WMA. To activate folder random play, press the RDM button. You will see F-RDM in the display. The system will then select and play files randomly. This continues until you deactivate folder random play by pressing and holding the RDM button.

Each time you press and release the RDM button, the mode changes from folder random play, to within a disc random play, then to normal play.

SCAN — The scan function samples all the tracks/files on the disc in the order they are recorded on the disc. To activate the scan feature, press the SCAN button. You will see SCAN in the display. You will get a 10 second sampling of each track on the disc. You will also see a track/file name in the display. Press and hold the SCAN button to get out of the system and play the last track sampled.

In MP3/WMA mode

F-SCAN — This feature, when activated, samples the first file of each folder for 10 seconds. To activate the folder scan feature, press the SCAN button until you see F-SCAN in the display. The folder name is also displayed. To hear the rest of the folder, press the SCAN button, within 10 seconds. If you do not, the system advances to the next folder, plays 10 seconds of it, and continues throughout the rest of the folder the same way. When the system samples the first file of all folders, F-SCAN is cancelled, and the system plays normally.

To Stop Playing a Disc

Press the eject button () to remove the CD. If you eject the CD, but do not remove it from the slot, the system will automatically reload the CD after 10 seconds and put it in pause mode. To begin playing, press the CD button.

Press the AM/FM button (AM or FM button) to switch to the radio while a CD is playing. Press the CD button to play the CD.

If you turn the system off while a disc is playing, either with the PWR/VOL knob or by turning off the ignition switch, the disc will stay in the drive. When you turn the system back on, the disc will begin playing where it left off.

Protecting Discs

For information on how to handle and protect compact discs, see page [141](#).



Disc Player Error Messages

The chart on the right explains the error messages you may see in the display while playing a disc.

If you see an error message in the display while playing a disc, press the eject button. After ejecting the disc, check it for damage or deformation. If there is no damage, insert the disc again.

If there is still a problem, the error message will reappear. Press the eject button, and pull out the disc.

Insert a different disc. If the new disc plays, there is a problem with the first disc. If the error message cycle repeats and you cannot clear it, take your vehicle to a dealer.

Indication	Cause	Solution
 DISC ERROR	FOCUS Error	Press the EJECT button, and pull out the disc. Check if it is inserted correctly in the disc player. Make sure the disc is not scratched or damaged.
 MECH ERROR	Mechanical Error	Press the EJECT button, and pull out the disc. Check the disc for damage or deformation. If the disc cannot be pulled out, or the error message does not disappear after the disc is ejected, see your dealer.
 HEAT ERROR	High temperature	Will disappear when the temperature returns to normal.

(A type)
Canadian model

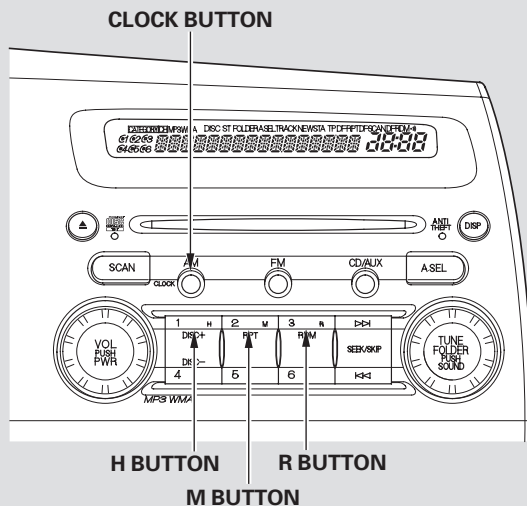

(B type)
U.S. model without navigation system

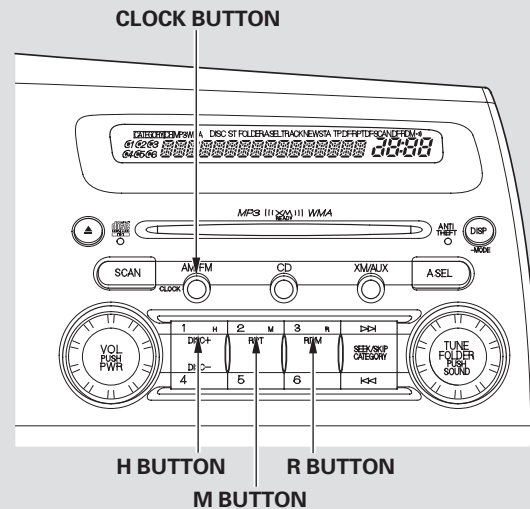

CONTINUED

Setting the Clock

To set the time, press the CLOCK (AM/FM or AM) button until you hear a beep, then release the button. The displayed time begins to blink.

Change the hour by pressing the H (preset 1) button until the numbers advance to the desired time. Change the minute by pressing the M (preset 2) button until the numbers advance to the desired time.

Press the CLOCK button again to enter the set time.

You can quickly set the time to the nearest hour. If the displayed time is before the half hour, pressing the CLOCK button until you hear a beep, then pressing the R (preset 3) button sets the clock back to the previous hour. If the displayed time is after the half hour, the clock sets forward to the beginning of the next hour.

(C type)

with navigation system

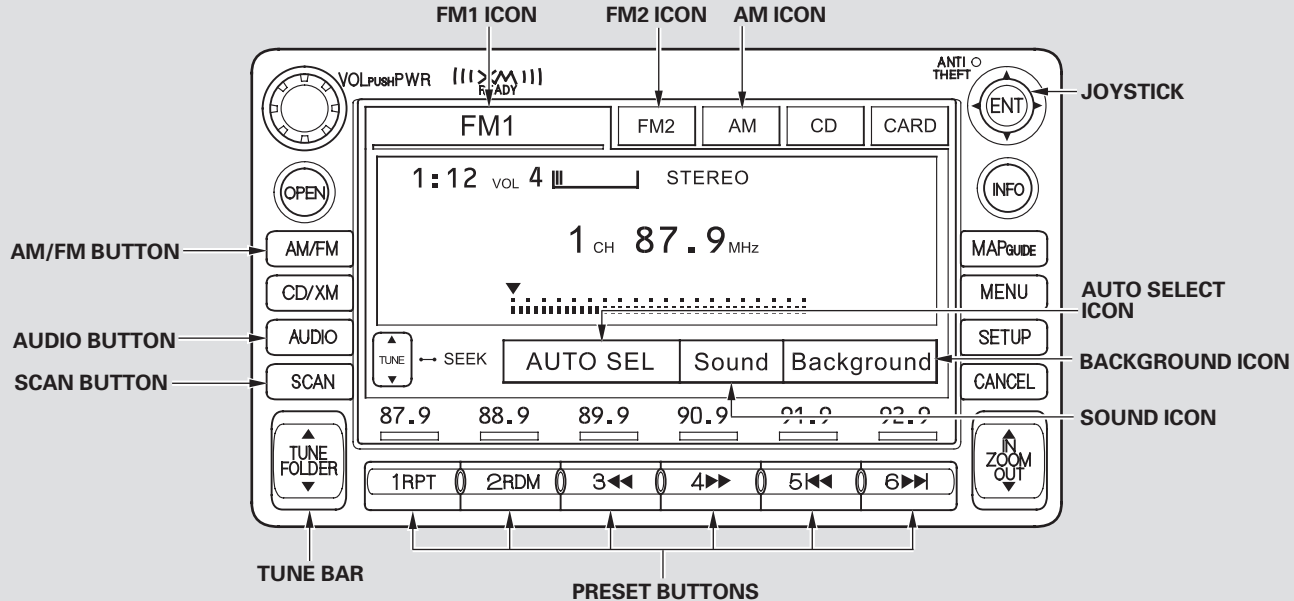

Playing the Radio (Vehicles with Navigation System)

Voice Control System

In addition to the standard audio controls, the audio system in your vehicle can be operated using the voice control system. See the Navi section in your Quick Start Guide for an overview of this system, and the navigation system manual for complete details.

To Play the Radio

The ignition switch must be in the ACCESSORY (I) or ON (II) position. Turn the system on by pushing the PWR/VOL knob. Adjust the volume by turning the same knob.

Push the AUDIO button to show the audio system screen. You can also operate the audio system without showing the audio system screen by using the standard controls. The status bar is shown at the bottom of the screen each time you press a button.

The band and frequency that the radio was last tuned to is displayed. To change bands, press the AM/FM button, or touch the desired band icon (FM1, FM2, or AM). On the FM band, STEREO will be displayed if the station is broadcasting in stereo. Stereo reproduction on AM is not available.

To Select a Station

You can use any of five methods to find radio stations on the selected band: **TUNE**, **SEEK**, **SCAN**, the preset buttons, and **AUTO SELECT**.

TUNE — Use the TUNE bar to tune the radio to a desired frequency. Press the ▲ bar to tune to a higher frequency, and the ▼ bar to tune to a lower frequency. When you press and hold the ▲ or ▼ bar, the system beeps twice, and the frequency goes up or down until you release the bar.

SEEK — The SEEK function searches up and down from the current frequency to find a station with a strong signal. To activate it, press and hold ▲ or ▼ on the TUNE bar until you hear a beep, then release the bar.

SCAN — The scan function samples all stations with strong signals on the selected band. To activate it, press the SCAN button, then release it. You will see SCAN in the display. The system will scan for a station with a strong signal. When it finds one, it will stop and play that station for about 10 seconds. If you do nothing, the system will scan for the next strong station and play it for 10 seconds. When it plays a station that you want to listen to, press the SCAN button again.

Preset — Each preset button can store one frequency on AM and two frequencies on FM.

1. Select the desired band, AM or FM. FM1 and FM2 let you store two frequencies with each preset button.
2. Use the tune, seek, or scan function to tune the radio to a desired station.
3. Pick a preset button, and hold it until you hear a beep.
4. Repeat steps 1 through 3 to store a total of six stations on AM and twelve stations on FM.

AUTO SELECT — If you are traveling far from home and can no longer receive your preset stations, you can use the auto select feature to find stations in the local area.

Press the AUTO SEL icon. “AUTO SEL” flashes in the display, and the system goes into scan mode for several seconds. It stores the frequencies of six AM, and twelve FM stations in the preset buttons.

You will see a “0” displayed after pressing a preset button if auto select cannot find a strong station for every preset button.

If you do not like the stations auto select has stored, you can store other frequencies on the preset buttons. Use the TUNE, SEEK, or SCAN functions to find stations, then store them in the preset buttons as described.

To turn off Auto Select, press the AUTO SEL icon. This restores the presets you originally set.

To Change the Background Image

There are three modes of display: level (the audio level appears as ten vertical bar graphs), spectrum analysis (the audio level appears as ripples of water), and off (a plain background is displayed). Each time you touch the Background icon, the mode changes.

CONTINUED

Playing the Radio (Vehicles with Navigation System)

Adjusting the Sound

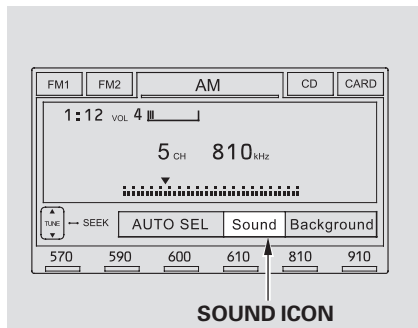

To adjust the sound, push the AUDIO button, then enter the sound grid by touching the SOUND icon on the display.

Treble/Bass — To adjust the treble and bass, touch + or – on each side of the treble or bass adjustment bar, or move the joystick. The adjustment bar shows you the current setting.

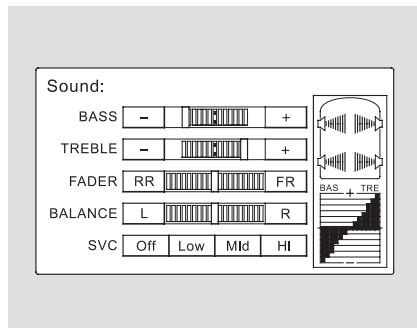

Left/Right Balance and Front/Rear Fader — These modes adjust the strength of the sound coming from each speaker. Left/Right balance adjusts the side-to-side strength, while Front/Rear fader adjusts the front-to-back strength. To adjust the left/right balance, touch the “L” or “R” icon, or move the joystick. To adjust the front/rear fader, touch the “FR” or “RR” icon, or move the joystick.

Speed-sensitive volume compensation (SVC) — The SVC mode controls the volume based on vehicle speed. The faster you go, the louder the audio volume becomes. As you slow down, the audio volume decreases.

The default setting is Mid. If you feel the sound is too loud, choose low. If you feel the sound is too quiet, choose Hi.

To see the audio display when you are finished adjusting the sound, wait 5 seconds.

Audio System Lighting

You can use the instrument panel brightness control buttons to adjust the illumination of the audio system (see page 74). The audio system illuminates when the parking lights are on, even if the radio is off.

(C type)
with navigation system

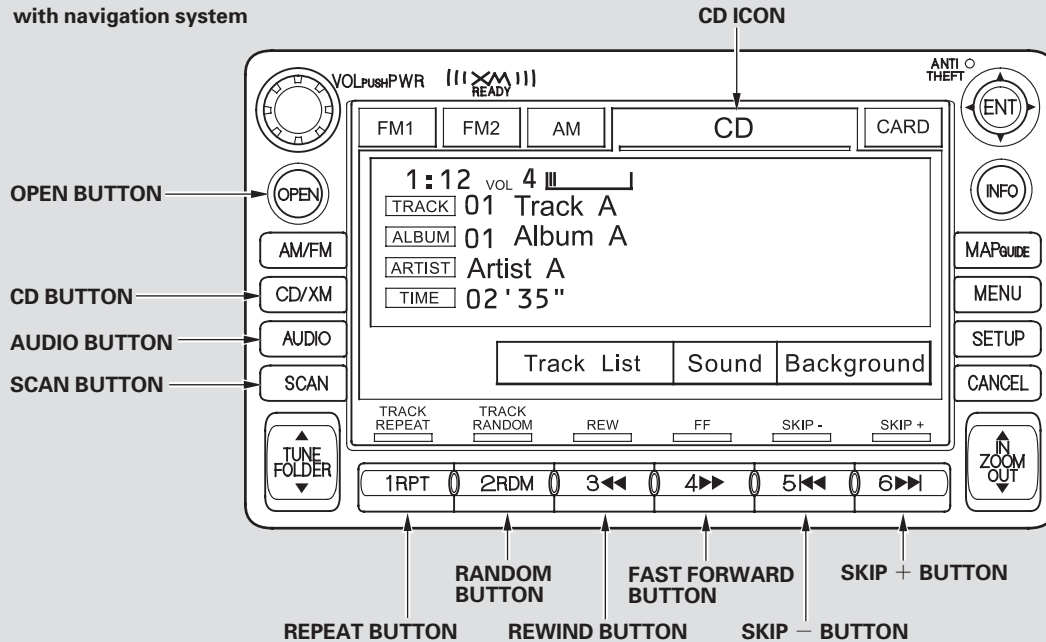

Playing a Disc (Vehicles with Navigation System)

Disc Player

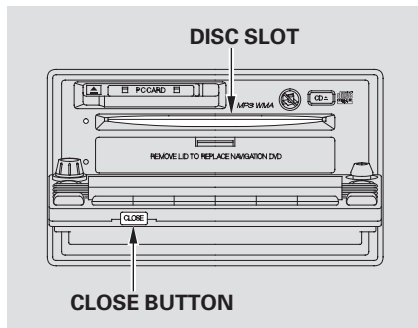

With the ignition in the ACCESSORY (I) or ON (II) position, press the OPEN button, and insert a disc about halfway into the disc slot. The drive will pull the disc in the rest of the way, and the disc will begin to play. You operate the disc player with the same controls used for the radio. The number of the track playing is shown in the display. The system will continuously play a disc until you change modes.

NOTICE

Avoid using discs with adhesive labels. The label can curl up and cause the disc to jam in the unit.

Push the AUDIO button to show the audio system screen. You can also operate the audio system without showing the audio system screen by using the standard controls. The status bar is shown at the bottom of the screen each time you press a button.

The player can also play CD-TEXT, MP3, and WMA formats.

When you play CD-TEXT, you will see the track name, artist name, and album name on the screen. When you play MP3/WMA discs, you will see the track name and folder name on the screen. If the disc was not recorded with this information, it will not be displayed.

To Change Tracks

Push the ►► button to play the next track on the disc. Push the ◀◀ button once to replay the track in play; press it twice to replay the previous track. To move rapidly within a track, press and hold the ◀◀ or the ►► button.

REPEAT — Press the RPT button to continuously replay a track. You will see REPEAT in the display. Press the RPT button again to turn it off. In MP3/WMA mode, press and hold the RPT button to activate folder repeat. Folder repeat continuously replays the folder.

RANDOM – Press the RDM button to play the tracks in random order. You will see RANDOM in the display. Press the RDM button again to return to normal play. In MP3/WMA mode, press and hold the RDM button to activate folder random. Folder random plays the tracks in random order within the current folder.

SCAN – The SCAN function samples all the tracks on the disc in the order they are recorded. To activate it, press and release the SCAN button. You will see SCAN in the display, and you will get a 10 second sampling of each track on the disc. Press the SCAN button again to get out of scan mode. In MP3/WMA mode, press and hold the SCAN button to activate folder scan. Folder scan samples the first track of each folder.

To Choose a Track

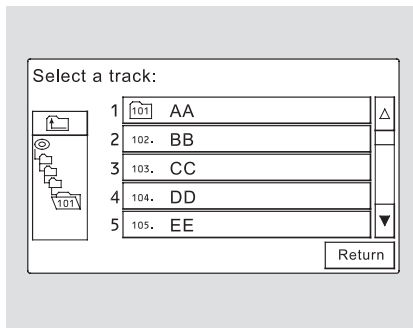

You can also choose a track directly from a track list. Touch TRACK LIST on the screen, and the track list screen is shown.

If you are playing a CD, the screen shows the track number. If you are playing a CD-TEXT disc, the track name is also shown. If you are playing an MP3 or WMA disc, the folders will also be shown.

If there are no track names, the track numbers are displayed. You will see the current track highlighted. Select the desired track. If you are checking the track list and want to go back to previous screen, touch Return.

Playing a Disc (Vehicles with Navigation System)

To Stop Playing a Disc

To take the system out of disc mode, press the AM/FM button or CD/XM button (if the XM radio is connected). You can also touch the FM1, FM2, AM, or CARD icon on the screen. To return to disc mode, press the CD/XM button or touch the CD icon.

Removing a Disc

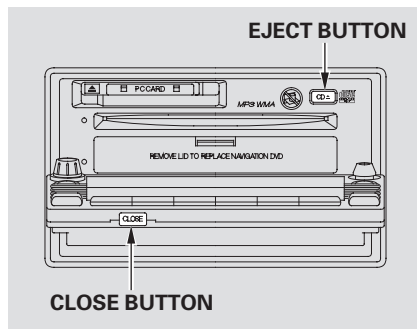

Press the OPEN button. The screen folds back, and the disc player appears. Press the eject button (▲) to remove the disc. If you eject the disc, but do not remove it from the slot, the system will automatically reload it after 10 seconds and will remain there in a pause mode.

To close the screen, press the CLOSE button. The screen will not close if you have a partially inserted CD or PC card.

Playing an MP3/WMA Disc

The disc player plays MP3/WMA folders in recorded order. Maximum playable folder layers are 8, total playable folders are 99, and total playable tracks are 999 per disc. If your disc has a complex structure, the disc player takes some time to read the disc before playing it.

Protecting Discs

For information on how to handle and protect discs, see page 141.

(C type)

With navigation system

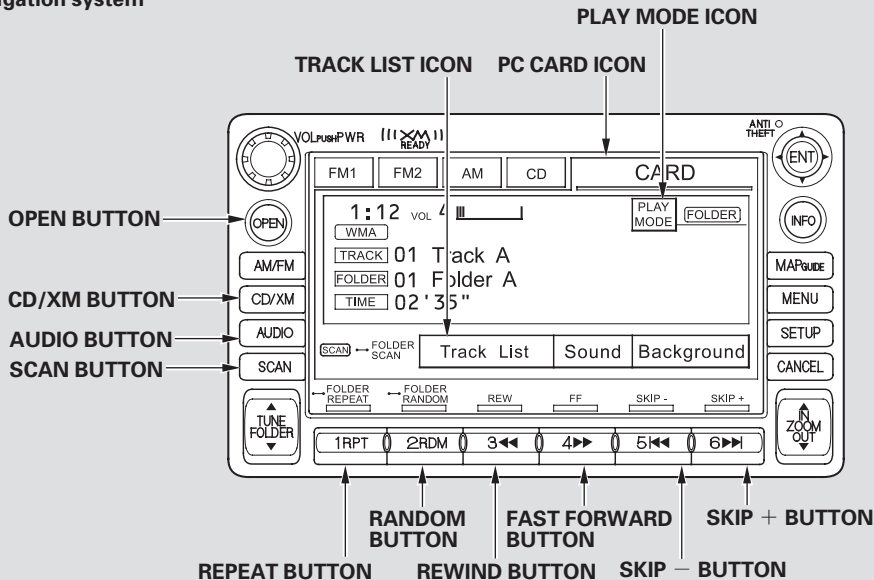

Playing a PC Card (Vehicles with Navigation System)

PC Card

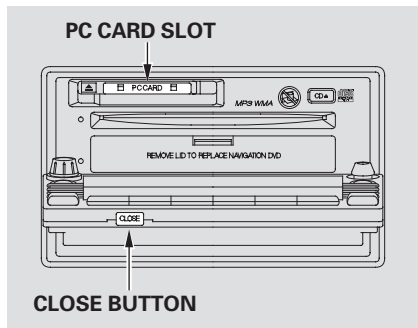

With the ignition in the ACCESSORY (I) or ON (II) position, press the OPEN button, insert a PC card all the way into the card slot, then press the CLOSE button. The PC card will begin to play. You operate the PC card with the same controls used for the radio. The number of the track playing is shown in the display. The system will continuously play a card until you change modes.

Push the AUDIO button to show the audio system screen. You can also operate the audio system without showing the audio system screen by using the standard controls. The status bar is shown at the bottom of the screen each time you press a button.

The PC card player can play MP3 and WMA formats.

NOTE:

- When you insert a PC card into the slot, make sure you put it in straight. If you cannot insert it, remove it, and insert again.
- Do not keep PC cards in the vehicle. Direct sunlight and high heat will damage them.
- To avoid damaging the card reader, do not insert hard disc drive cards into the PC card slot.

- You cannot close the display until the PC card is inserted all the way in or removed.
- Never insert foreign objects into the PC card slot.

The system may not be able to read some memory cards depending on the type of memory card or combination of PC card adaptor and memory card. Recommended memory cards are CompactFlash and Flash ATA memory cards.

Play Mode

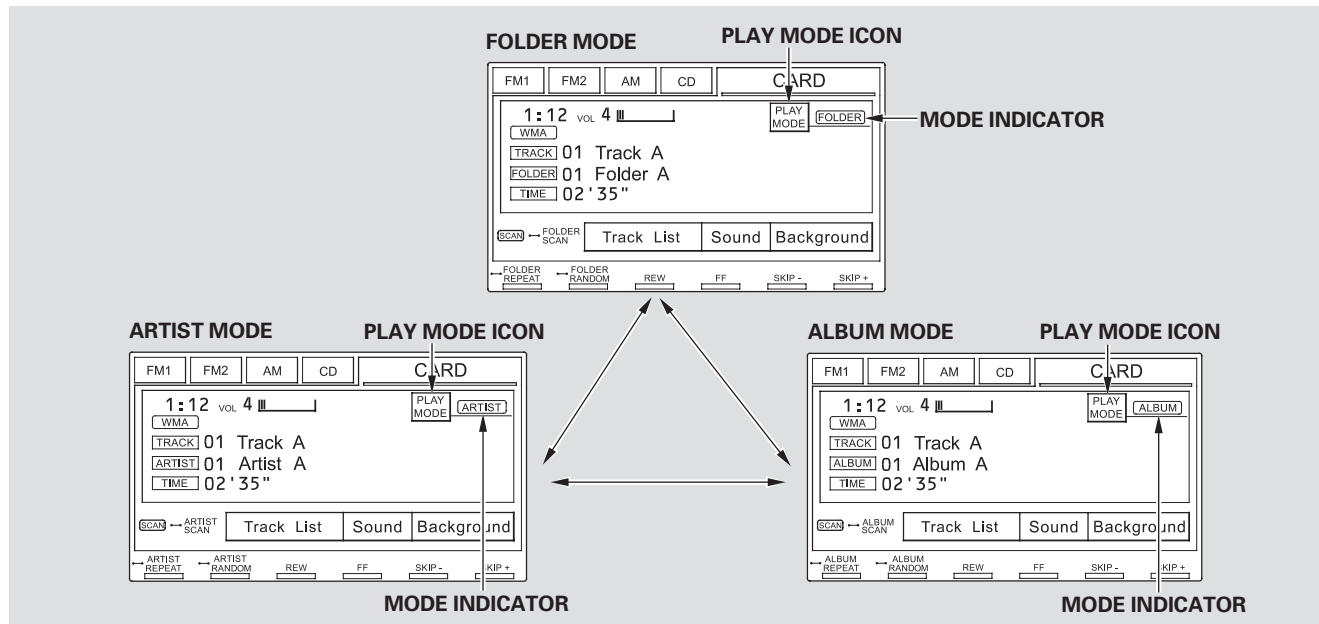

CONTINUED

Playing a PC Card (Vehicles with Navigation System)

To select a play mode

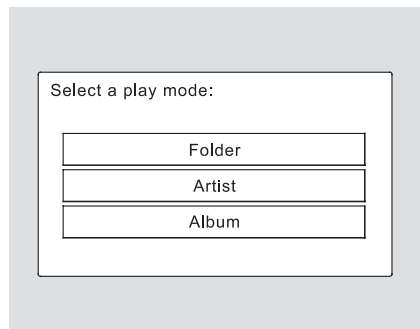

There are three modes to choose from: folder, artist, and album. Touch the PLAY MODE icon, then choose one.

Folder mode plays tracks in the order they are recorded in. Artist mode plays tracks in alphabetical order by artist and song title. Album mode plays albums in alphabetical order. If the ID3 tag information is not in your card, the play mode might not work properly.

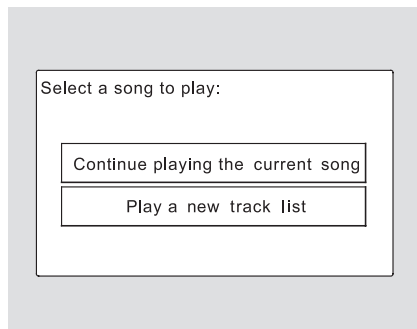

Choose “Continue playing the current song” or “Play a new track list.” Continue playing the Current Song plays the current song, then goes into the play mode you chose. Play a new track list plays the play mode you chose.

You can always go back to the previous screen by pressing the CANCEL button. Press the AUDIO button to exit.

To Change Tracks

Push the ►► button to play the next track. Push the ◀◀ button once to replay the track in play; press it twice to replay the previous track. To move rapidly within a track, press and hold the ◀◀ or the ►► button.

REPEAT — Press the RPT button to continuously replay a track. You will see TRACK REPEAT in the display. Press RPT button again to turn it off.

Press and hold the RPT button until you hear a beep. Folder, artist, or album repeat will be activated depending on which play mode you chose. Folder repeat continuously replays the folder. Artist repeat continuously replays by that artist. Album repeat continuously replays the album. Press the RPT button again to turn it off.

RANDOM — Press the RDM button to play the tracks in random order. You will see TRACK RANDOM in the display. Press the RDM button again to return to normal play.

Press and hold the RDM button until you hear a beep. Folder, artist, or album random will be activated depending on which play mode you chose. Folder random plays the tracks in random order within a folder. Artist random plays the artist's tracks in random order. Album random plays the tracks in random order within an album. Press the RDM button again to turn it off.

SCAN — The SCAN function samples all the tracks on the PC card in the order they are recorded. To activate it, press and release the SCAN button. You will see TRACK SCAN in the display, and you will get a 10 second sampling of each track on the card. Press the SCAN button again to get out of scan mode.

Press and hold the SCAN button until you hear a beep. Folder, artist, or album scan will be activated depending on which play mode you chose. You will get a 10 second sampling of each track. Folder scan samples the first track of each folder. Artist scan samples the first track of each artist. Album scan samples the first track of each album. To hear the rest of the folder, the artist, or the album, press the SCAN button, within 10 seconds. If you do not, the system advances to the next folder, artist, or album, plays for 10 seconds of it, and continues throughout the rest of folders, artists, or albums the same way. When the system reaches the last folder, artist, or album, the scan mode is cancelled, and the PC card plays normally.

Playing a PC Card (Vehicles with Navigation System)

To Choose a Track

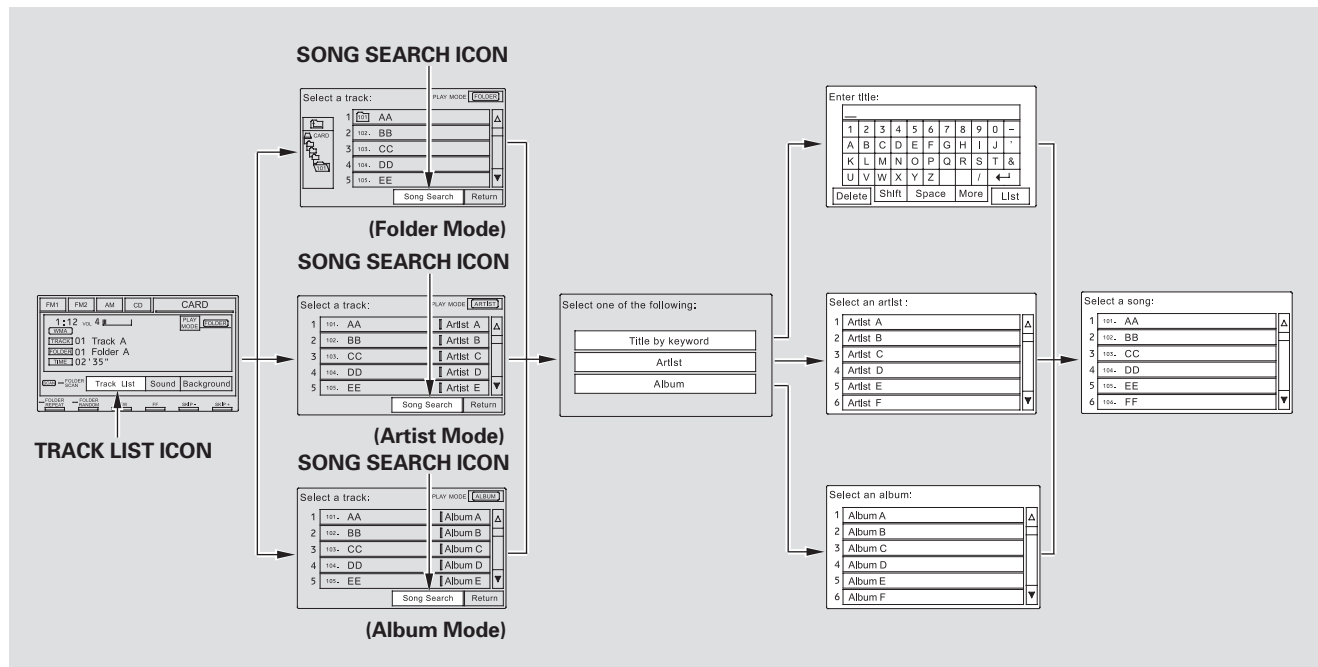

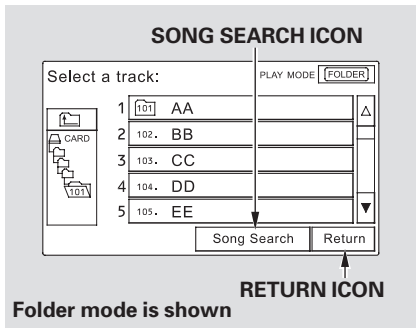

You can also choose a track directly from a track list. Touch TRACK LIST on the screen, and the track list screen will be shown. The display changes depending on which play mode you chose. You will see the current track highlighted. Select the desired track. If you want to go back to the previous screen, press Return.

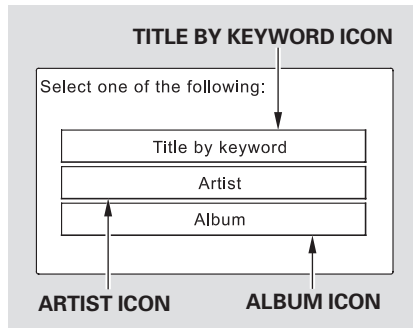

If you want to search for a particular song, select Song Search on the track list screen. You can search a song from Title by Keyword, Artist, or Album.

Search by Title by Keyword

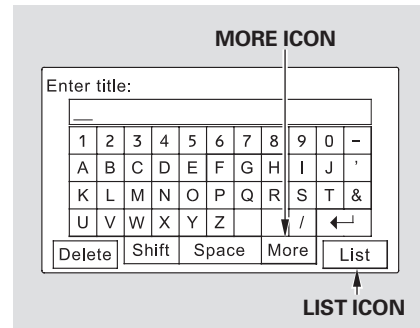

If you choose Title by Keyword, enter the title or any keyword, then press List. The system will search to find the song or songs.

If you cannot find characters, select More to show other characters.

CONTINUED

Playing a PC Card (Vehicles with Navigation System)

Select a song:

1	101. AA	▲
2	102. BB	
3	103. CC	
4	104. DD	
5	105. EE	
6	106. FF	▼

Then select a song.

Search by Artist

Select an artist :

1	Artist A	▲
2	Artist B	
3	Artist C	
4	Artist D	
5	Artist E	
6	Artist F	▼

If you choose Artist, select an artist, then select a song.

Search by Album

Select an album:

1	Album A	▲
2	Album B	
3	Album C	
4	Album D	
5	Album E	
6	Album F	▼

If you choose Album, select an album, then select a song.

Playing an MP3/WMA Card

The player plays recorded MP3/WMA cards in recorded order.

Maximum playable folder layers are 8, total playable folders are 99, and total playable tracks are 999 per card. If your card has a complex structure, the player takes some time to read the card before playing it.

To Stop Playing a Card

To take the system out of card mode, press the AM/FM button or CD/XM button (if a disc is loaded or the XM radio is connected). You can also touch the FM1, FM2, AM, or CD icon on the screen. To return to card mode, press the CD/XM button or touch the CARD icon.

Removing a PC Card

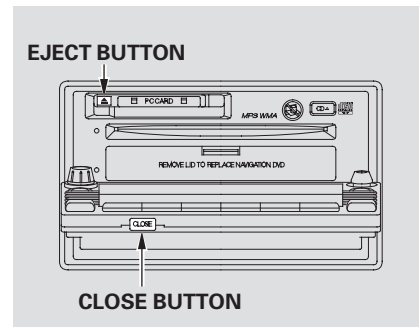

Press the OPEN button. The screen folds back, and the player appears. Press the eject button (▲), and remove the card, then press the CLOSE button.

You cannot close the display until the PC card is inserted all the way in or removed.

Disc Player Error Messages (Vehicles with Navigation System)

The chart on the right explains the error messages you may see in the display while playing a disc.

If you see an error message in the display while playing a disc, press the eject button. After ejecting the disc, check it for damage or deformation. If there is no damage, insert the disc again.

If there is still a problem, the error message will reappear. Press the eject button, and pull out the disc.

Insert a different disc. If the new disc plays, there is a problem with the first disc. If the error message cycle repeats and you cannot clear it, take your vehicle to a dealer.

Indication	Cause	Solution
CD DISC ERROR	FOCUS Error	Press the EJECT button, and pull out the disc. Check if it is inserted correctly in the disc player. Make sure the disc is not scratched or damaged.
CD MECH ERROR	Mechanical Error	Press the EJECT button, and pull out the disc. Check the disc for damage or deformation. If the disc cannot be pulled out, or the error message does not disappear after the disc is ejected, see your dealer.
CD HEAT ERROR	High temperature	Will disappear when the temperature returns to normal.

Radio Frequencies

The radio can receive the complete AM and FM bands.

Those bands cover these frequencies:

AM band: 530 to 1,710 kHz

FM band: 87.7 to 107.9 MHz

Radio stations on the AM band are assigned frequencies at least 10 kHz apart (530, 540, 550). Stations on the FM band are assigned frequencies at least 0.2 MHz apart (87.9, 88.1, 88.3).

Stations must use these exact frequencies. It is fairly common for stations to round-off the frequency in their advertising, so your radio could display a frequency of 100.9 even though the announcer may identify the station as "FM101."

Radio Reception

How well the radio receives stations is dependent on many factors, such as the distance from the station's transmitter, nearby large objects, and atmospheric conditions.

A radio station's signal gets weaker as you get farther away from its transmitter. If you are listening to an AM station, you will notice the sound volume becoming weaker, and the station drifting in and out. If you are listening to an FM station, you will see the stereo indicator flickering off and on as the signal weakens. Eventually, the stereo indicator will go off and the sound will fade completely as you get out of range of the station's signal.

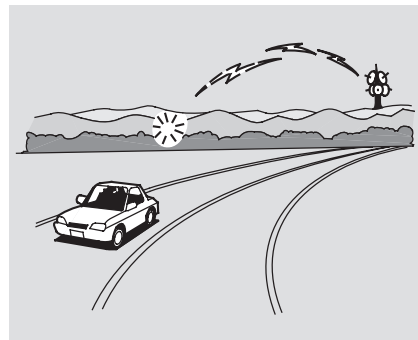

Driving very near the transmitter of a station that is broadcasting on a frequency close to the frequency of the station you are listening to can also affect your radio's reception. You may temporarily hear both stations, or hear only the station you are close to.

CONTINUED

Radio Reception

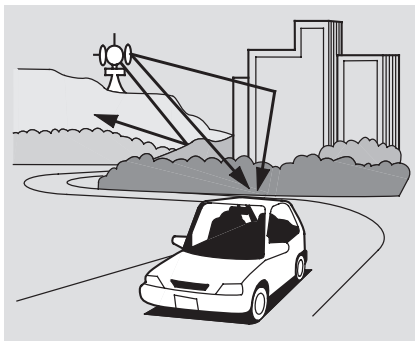

Radio signals, especially on the FM band, are deflected by large objects such as buildings and hills. Your radio then receives both the direct signal from the station's transmitter, and the deflected signal. This causes the sound to distort or flutter. This is a main cause of poor radio reception in city driving.



Radio reception can be affected by atmospheric conditions such as thunderstorms, high humidity, and even sunspots. You may be able to receive a distant radio station one day and not receive it the next day because of a change in conditions.

Electrical interference from passing vehicles and stationary sources can cause temporary reception problems.

*As required by the FCC:
Changes or modifications not expressly
approved by the party responsible for
compliance could void the user's
authority to operate the equipment.*

General Information

- When using CD-R or CD-RW discs, use only high quality discs labeled for audio use.
- When recording a CD-R or CD-RW, the recording must be closed for it to be used by the system.
- Play only standard round discs. Odd-shaped discs may jam in the drive or cause other problems.
- Handle your discs properly to prevent damage and skipping.

NOTICE

Do not use discs with adhesive labels. The label can curl up and cause the disc to jam in the unit.

Protecting Discs

When a disc is not being played, store it in its case to protect it from dust and other contamination. To prevent warpage, keep discs out of direct sunlight and extreme heat.

To clean a disc, use a clean soft cloth. Wipe across the disc from the center to the outside edge.

A new disc may be rough on the inner and outer edges. The small plastic pieces causing this roughness can flake off and fall on the recording surface of the disc, causing skipping or other problems. Remove these pieces by rubbing the inner and outer edges with the side of a pencil or pen.

Never try to insert foreign objects in the disc player.

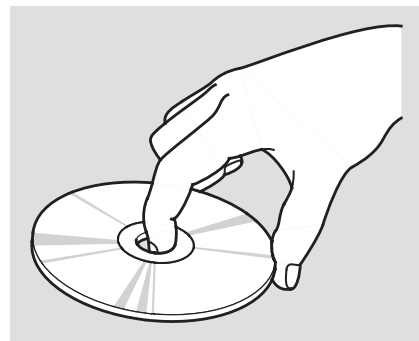

Handle a disc by its edges; never touch either surface. Do not place stabilizer rings or labels on the disc. These, along with contamination from finger prints, liquids, and felt-tip pens, can cause the disc to not play properly, or possibly jam in the drive.

Radio Theft Protection

Your vehicle's audio system will disable itself if it is disconnected from electrical power for any reason. To make it work again, you must enter a specific five-digit code (except for model with navigation system)/four-digit code (model with navigation system) in the preset buttons. Because there are hundreds of number combinations possible from five or four-digits, making the system work without knowing the exact code is nearly impossible.

You should have received a card that lists your audio system's code and serial numbers. It is best to store this card in a safe place at home. In addition, you should write the audio system's serial number in this owner's manual.

If you lose the card, you must obtain the code number from a dealer. To do this, you will need the system's serial number.

If your vehicle's battery is disconnected or goes dead, or the radio fuse is removed, the audio system will disable itself. Use the preset buttons to enter the five-digit code (except for model with navigation system)/four-digit code (model with navigation system). The code is on the radio code card included in your owner's manual kit. When it is entered correctly, the radio will start playing.

If you make a mistake entering the code, do not start over; complete the five-digit (except for model with navigation system)/four-digit (model with navigation system) sequence, then enter the correct code. You have 10 tries to enter the correct code. If you are unsuccessful in 10 attempts, you must then leave the system on for 1 hour before trying again.

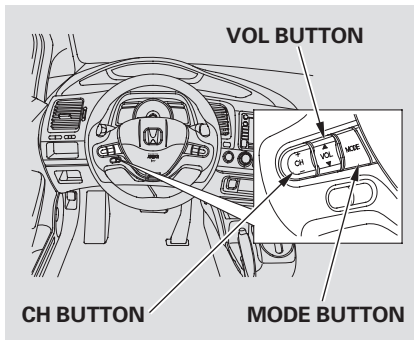

Three controls for the audio system are mounted in the steering wheel hub. These let you control basic functions without removing your hand from the wheel.

The VOL button adjusts the volume up (▲) or down (▼). Press the top or bottom of the button, hold it until the desired volume is reached, then release it.

The MODE button changes the mode. Pressing the button repeatedly selects FM1, FM2, AM, a disc (if a disc is loaded), or a PC card (if a card is loaded).

If you are listening to the radio, use the CH button to change stations. Each time you press the top (+) of the button, the system goes to the next preset station on the band you are listening to. Press the bottom (–) to go back to the previous station. If you press and hold the CH button (+) or (–) until you hear a beep, the system goes into the seek mode. It finds a station with a strong signal.

If you are playing a disc, the system skips to the beginning of the next track each time you press the top (+) of the CH button. Press the bottom (–) to return to the beginning of the current track. Press it again to return to the previous

track. You will see the disc and track numbers in the display. If you press and hold the CH button (+) or (–) until you hear a beep, you can select a different folder.

On models with navigation system
To use the voice control system, refer to the navigation system manual.

Auxiliary Input Jack

The auxiliary input jack is under the accessory power socket. The system will accept auxiliary input from standard audio accessories.

When the appropriate audio unit is connected to the auxiliary input jack, press the CD/XM or XM/AUX button to select the unit.

Security System

The security system helps to protect your vehicle and valuables from theft. The horn sounds and a combination of headlights (low beam), parking lights, side marker lights, and taillights flash if someone attempts to break into your vehicle or remove the radio. This alarm continues for 2 minutes, then it stops. To reset an alarming system before the 2 minutes have elapsed, unlock the driver's door with the key or the remote transmitter.

The security system automatically sets 15 seconds after you lock the doors, hood, and trunk. For the system to activate, you must lock the doors from the outside with the key, driver's lock tab, door lock switch, or remote transmitter. The security system indicator on the instrument panel starts blinking immediately to show you the system is setting itself.

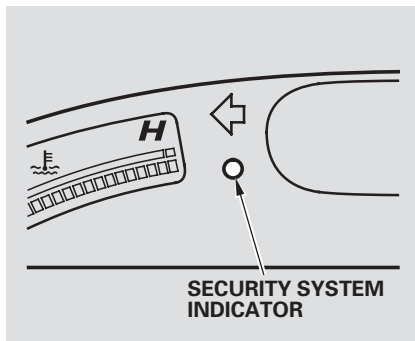

Once the security system is set, opening any door, the trunk, or the hood without using the key or the remote transmitter will cause it to alarm. It also alarms if the radio is removed from the dashboard or the wiring is cut.

With the system set, you can still open the trunk with the master key or the remote transmitter without triggering the alarm. The alarm will sound if the trunk lock is forced, or the trunk is opened with the trunk release handle.

The security system will not set if the hood, trunk, or any door is not fully closed. If the system will not set, check the door and trunk open indicators on the instrument panel (see page 62) to see if the doors and trunk are fully closed. Since it is not part of the monitor display, manually check the hood.

NOTE: To see if the system is set after you exit the vehicle, press the LOCK button on the remote transmitter within 5 seconds. If the system is set, the horn will beep once.

Do not attempt to alter this system or add other devices to it.

Cruise control allows you to maintain a set speed above 25 mph (40 km/h) without keeping your foot on the accelerator pedal. It should be used for cruising on straight, open highways. It is not recommended for city driving, winding roads, slippery roads, heavy rain, or bad weather.

⚠ WARNING

Improper use of the cruise control can lead to a crash.

Use the cruise control only when traveling on open highways in good weather.

Using the Cruise Control

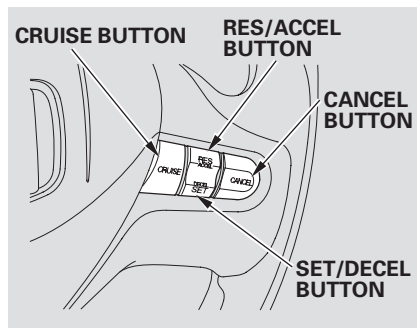

1. Push the CRUISE button on the steering wheel. The CRUISE MAIN indicator on the instrument panel comes on.
2. Accelerate to the desired cruising speed above 25 mph (40 km/h).

3. Press and release the SET/DECEL button on the steering wheel. The CRUISE CONTROL indicator on the instrument panel comes on to show the system is now activated.

Cruise control may not hold the set speed when you are going up and down hills. If your speed increases going down a hill, use the brakes to slow down. This will cancel cruise control. To resume the set speed, press the RES/ACCEL button. The indicator on the instrument panel will come back on.

When climbing a steep hill, the automatic transmission may downshift to hold the set speed.

Cruise Control

Changing the Set Speed

You can increase the set cruising speed in any of these ways:

- Press and hold the RES/ACCEL button. When you reach the desired cruising speed, release the button.
- To increase your speed in very small amounts, tap the RES/ACCEL button. Each time you do this, the vehicle will speed up about 1 mph (1.6 km/h).
- Push on the accelerator pedal. Accelerate to the desired cruising speed, then press the SET/DECEL button.

You can decrease the set cruising speed in any of these ways:

- Press and hold the SET/DECEL button. Release the button when you reach the desired speed.
- To slow down in very small amounts, tap the SET/DECEL button. Each time you do this, your vehicle will slow down about 1 mph (1.6 km/h).
- Tap the brake pedal lightly with your foot. The CRUISE CONTROL indicator on the instrument panel will go out. When the vehicle slows to the desired speed, press the SET/DECEL button.

Even with the cruise control turned on, you can still use the accelerator pedal to speed up for passing. After completing the pass, take your foot off the accelerator pedal. The vehicle will return to the set cruising speed.

Resting your foot on the brake pedal causes cruise control to cancel.

Canceling Cruise Control

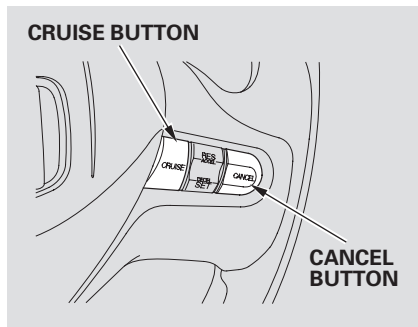

You can cancel cruise control in any of these ways:

- Tap the brake pedal.
- Push the CANCEL button on the steering wheel.
- Push the CRUISE button on the steering wheel.

Resuming the Set Speed

When you push the CANCEL button, or tap the brake or clutch pedal, the system will remember the previously set cruising speed. To return to that speed, accelerate to above 25 mph (40 km/h) then press and release the RES/ACCEL button. The CRUISE CONTROL indicator comes on. The vehicle will accelerate to the same cruising speed as before.

Pressing the CRUISE button turns the system off and erases the previous cruising speed.

Before you begin driving your vehicle, you should know what gasoline to use and how to check the levels of important fluids. You also need to know how to properly store luggage or packages. The information in this section will help you. If you plan to add any accessories to your vehicle, please read the information in this section first.

Break-in Period	150
Fuel Recommendation	150
Service Station Procedures	151
Refueling.....	151
Opening and Closing the Hood.....	152
Oil Check	153
Engine Coolant Check	154
Fuel Economy	154
Accessories and Modifications	156
Carrying Cargo	158

Break-in Period, Fuel Recommendation

Break-in Period

Help assure your vehicle's future reliability and performance by paying extra attention to how you drive during the first 600 miles (1,000 km). During this period:

- Avoid full-throttle starts and rapid acceleration.
- Do not change the oil until the scheduled maintenance time.
- Avoid hard braking for the first 200 miles (300 km).

You should also follow these recommendations with an overhauled or exchanged engine, or when the brakes are replaced.

Fuel Recommendation

Your vehicle is designed to operate on unleaded gasoline with a pump octane number of 87 or higher. Use of a lower octane gasoline can cause a persistent, heavy metallic rapping noise that can lead to engine damage.

We recommended using a quality gasoline containing detergent additives that help prevent fuel system and engine deposits.

In addition, in order to maintain good performance, fuel economy, and emissions control, we strongly recommend, in areas where it is available, the use of gasoline that does NOT contain manganese-based fuel additives such as MMT.

Use of gasoline with these additives may adversely affect performance, and cause the malfunction indicator lamp on your instrument panel to come on. If this happens, contact your authorized dealer for service.

Some gasoline today is blended with oxygenates such as ethanol or MTBE. Your vehicle is designed to operate on oxygenated gasoline containing up to 10 % ethanol by volume and up to 15 % MTBE by volume. Do not use gasoline containing methanol.

If you notice any undesirable operating symptoms, try another service station or switch to another brand of gasoline.

For further important fuel-related information, please refer to your **Quick Start Guide**.

Refueling

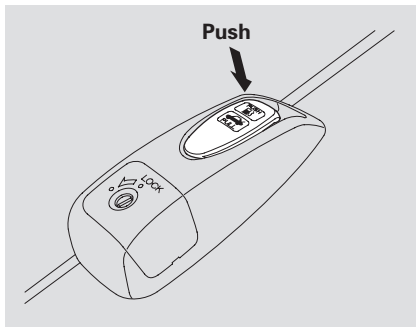

1. Park with the driver's side closest to the gas pump.
2. To open the fuel fill door, push down the lever on the left of the driver's seat.

⚠ WARNING

Gasoline is highly flammable and explosive. You can be burned or seriously injured when handling fuel.

- Stop the engine, and keep heat, sparks, and flame away.
- Handle fuel only outdoors.
- Wipe up spills immediately.

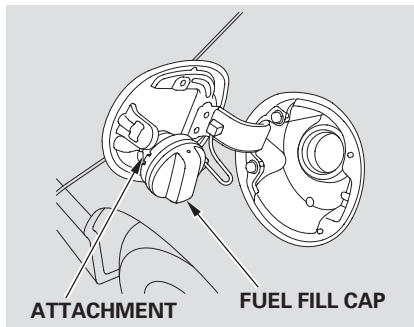

3. Remove the fuel fill cap slowly. You may hear a hissing sound as pressure inside the tank escapes. The fuel fill cap is attached to the fuel filler with a tether. Insert the attachment on the fuel fill cap into the slit on the fuel fill door.
4. Stop filling the tank after the fuel nozzle automatically clicks off. Do not try to "top off" the tank. Leave some room for the fuel to expand with temperature changes.

If the fuel nozzle keeps clicking off even though the tank is not full, there may be a problem with your vehicle's fuel vapor recovery system. The system helps keep fuel vapor from going into the atmosphere. Try filling at another pump. If this does not fix the problem, consult your dealer.

CONTINUED

5. Screw the fuel fill cap back on until it clicks at least once. If you do not properly tighten the cap, the malfunction indicator lamp may come on (see page 229). You will also see a “CHECK FUEL CAP” message on the information display.
6. Push the fuel fill door closed until it latches.

Opening and Closing the Hood

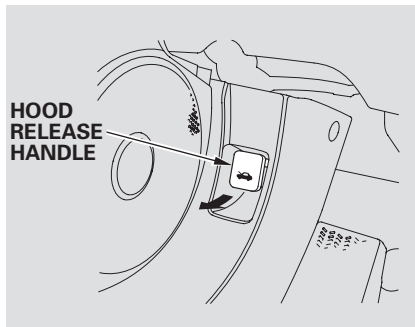

1. Park the vehicle, and set the parking brake. Pull the hood release handle located under the lower left corner of the dashboard. The hood will pop up slightly.
2. Put your fingers under the front edge of the hood near the center. Slide your hand to the left until you feel the hood latch handle. Push this handle up to release it. Lift up the hood.

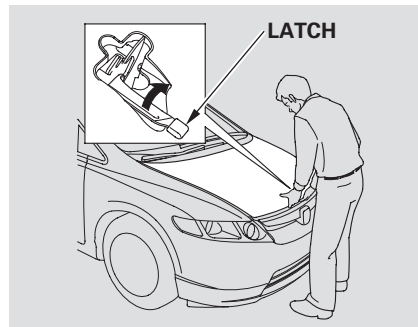

- If the hood latch handle moves stiffly, or if you can open the hood without lifting the handle, the mechanism should be cleaned and lubricated.
3. Holding the grip, pull the support rod out of its clip. Insert the end into the designated hole in the hood.

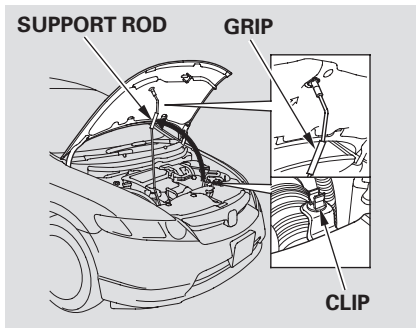

To close the hood, lift it up slightly to remove the support rod from the hole. Put the support rod back into its holding clip. Lower the hood to about a foot (30 cm) above the fender, then let it drop. Make sure it is securely latched.

Oil Check

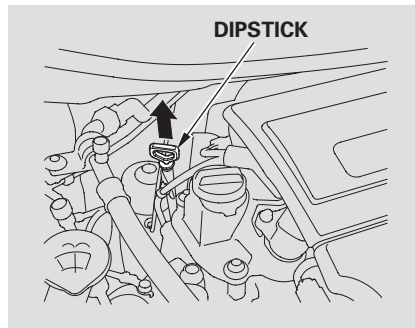

Wait a few minutes after turning the engine off before you check the oil.

1. Remove the dipstick (orange loop).
2. Wipe off the dipstick with a clean cloth or paper towel.
3. Insert the dipstick all the way back into its hole.

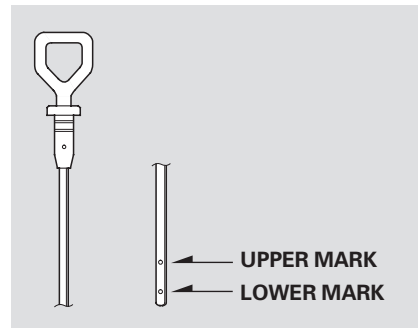

4. Remove the dipstick again, and check the level. It should be between the upper and lower marks.

If it is near or below the lower mark, see **Adding Engine Oil** on page [189](#).

Engine Coolant Check

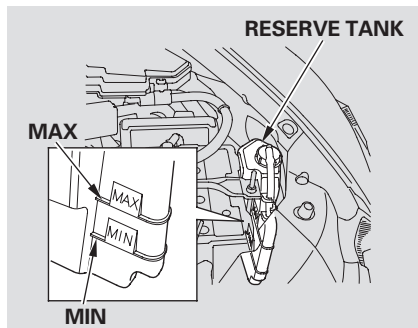

Look at the coolant level in the radiator reserve tank. Make sure it is between the MAX and MIN lines. If it is below the MIN line, see **Adding Engine Coolant** on page 192 for information on adding the proper coolant.

Refer to **Owner's Maintenance Checks** on page 184 for information about checking other items on your vehicle.

Improving Fuel Economy

- Always maintain your vehicle according to the maintenance messages displayed in the information display. See **Owner's Maintenance Checks** on page 184 .

For example, an underinflated tire causes more “rolling resistance,” which uses more fuel.

Engine oil also affects fuel economy. The fuel efficient, low-viscosity 0W-20 oil recommended for your Civic Hybrid is formulated to help the engine use less fuel. This oil is available at your dealer.

The build-up of snow or mud on your vehicle's underside adds weight and rolling resistance. Frequent cleaning helps your fuel mileage and reduces the chance of corrosion.

- Drive moderately. Rapid acceleration, abrupt cornering, and hard braking use more fuel.

You may find that your Civic Hybrid's unique combination of an engine and an electric motor has driving characteristics that are somewhat different from what you are used to.

- Try to maintain a constant speed. Every time you slow down and speed up, your vehicle uses extra fuel. Use cruise control when appropriate.
- Wind resistance causes vehicles to use more fuel at higher speeds. Driving at moderate speeds on the highway also reduces wind resistance and conserves fuel.
- The current fuel mileage display allows you to monitor your fuel mileage and adjust your driving habits to save fuel.
- Combine several short trips into one.
- The air conditioning puts an extra load on the engine which makes it use more fuel. Use the fresh-air ventilation when possible.

You may notice that using the A/C causes a greater drop in fuel economy than you are used to in other vehicles. Although the amount of extra fuel used by the A/C load on the engine is no greater than other vehicles, it is more noticeable because of your Civic Hybrid's excellent fuel mileage. Using the A/C in hot weather may result in fuel economy that is lower than expected.

Accessories and Modifications

Modifying your vehicle, or installing some non-Honda accessories, can make it unsafe. Before you make any modifications or add any accessories, be sure to read the following information.

Accessories

Your dealer has Honda accessories that allow you to personalize your vehicle. These accessories have been designed and approved for your vehicle, and are covered by warranty.

Although non-Honda accessories may fit on your vehicle, they may not meet factory specifications, and could adversely affect your vehicle's handling and stability.

WARNING

Improper accessories or modifications can affect your vehicle's handling, stability, and performance, and cause a crash in which you can be hurt or killed.

Follow all instructions in this owner's manual regarding accessories and modifications.

When properly installed, cellular phones, alarms, two-way radios, and low-powered audio systems should not interfere with your vehicle's computer controlled systems, such as your airbags and anti-lock brakes.

Before installing any accessory:

- Make sure the accessory does not obscure any lights, or interfere with proper vehicle operation or performance.
- Be sure electronic accessories do not overload electrical circuits (see page 231) or interfere with the proper operation of your vehicle.
- Before installing any electronic accessory, have the installer contact your dealer for assistance. If possible, have your dealer inspect the final installation.
- Do not install accessories on the side pillars or across the rear windows. In these areas, accessories may interfere with proper operation of the side curtain airbags.

Modifying Your Vehicle

Removing parts from your vehicle, or replacing components with non-Honda components could seriously affect your vehicle's handling, stability, and reliability.

Some examples are:

- Lowering your vehicle with a non-Honda suspension kit that significantly reduces ground clearance can allow the undercarriage to hit speed bumps or other raised objects, which could cause the airbags to deploy.
- Raising your vehicle with a non-Honda suspension kit can affect the handling and stability.
- Non-Honda wheels, because they are a universal design, can cause excessive stress on suspension components.

- Larger or smaller wheels and tires can interfere with the operation of your vehicle's anti-lock brakes and other systems.
- Modifying your steering wheel or any other part of your vehicle's safety features can make the systems ineffective.

If you plan to modify your vehicle, consult your dealer.

Carrying Cargo

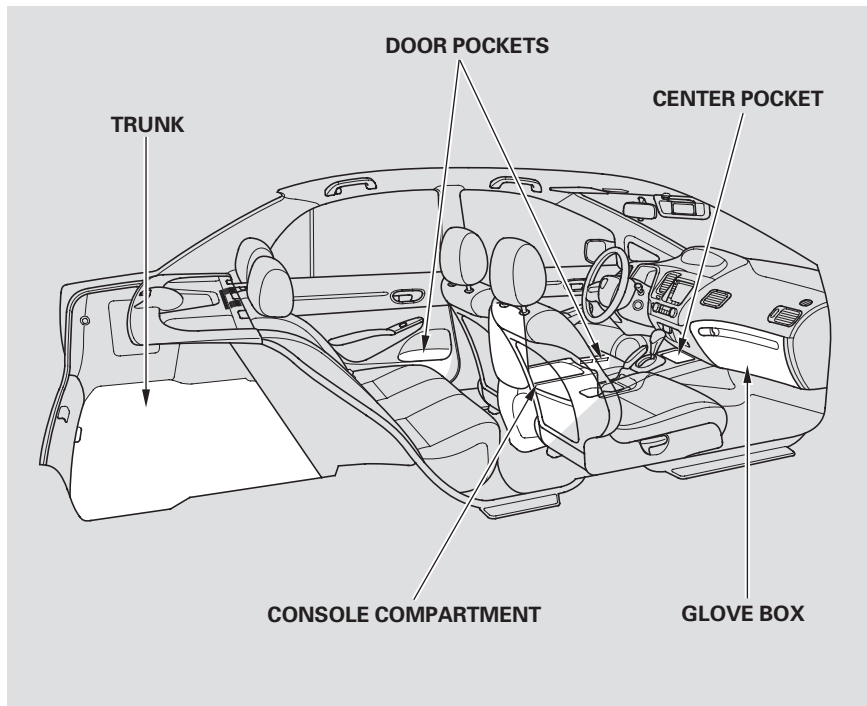

Your vehicle has several convenient storage areas:

- Glove box
- Door pockets
- Center pocket
- Console compartment
- Trunk

However, carrying too much cargo, or improperly storing it, can affect your vehicle's handling, stability, stopping distance, and tires, and make it unsafe. Before carrying any type of cargo, be sure to read the following pages.

Load Limits

The maximum load for your vehicle is 850 lbs (385 kg) for U.S. models and 395 kg for Canadian models. This figure includes the total weight of all occupants, cargo, and accessories.

⚠ WARNING

Overloading or improper loading can affect handling and stability and cause a crash in which you can be hurt or killed.

Follow all load limits and other loading guidelines in this manual.

Steps for Determining Correct Load Limit:

1. Locate the statement, “the combined weight of occupants and cargo should never exceed 850 lbs” on your vehicle’s placard. [The placard is on the driver’s doorjamb.]
2. Determine the combined weight of the driver and passengers that will be riding in your vehicle.
3. Subtract the combined weight of the driver and passengers from 850 lbs.

4. The resulting figure equals the available amount of cargo and luggage load capacity. For example, if the maximum load is 850 lbs and there will be five 150 lb passengers in your vehicle, the amount of available cargo and luggage load capacity is 100 lbs. $(850 - 750 (5 \times 150) = 100 \text{ lbs.})$
5. Determine the combined weight of luggage and cargo being loaded on the vehicle. That weight may not safely exceed the available cargo and luggage load capacity calculated in step 4.

In addition, the total weight of the vehicle, all passengers, accessories, and cargo must not exceed the Gross Vehicle Weight Rating (GVWR) or the Gross Axle Weight Rating (GAWR). Both are on a label on the driver’s doorjamb.

Carrying Cargo

Carrying Items in the Passenger Compartment

- Store or secure all items that could be thrown around and hurt someone during a crash.
- Do not put any items on the rear shelf that could cover the IMA battery air intake. They can block your view, or be thrown around the vehicle during a crash.
- Be sure items placed on the floor behind the front seats cannot roll under the seats and interfere with the pedals or seat operation.
- Keep the glove box closed while driving. If it is open, a passenger could injure their knees during a crash or sudden stop.

Carrying Cargo in the Trunk

- Distribute cargo evenly on the floor of the trunk, placing the heaviest items on the bottom and as far forward as possible.
- If you carry large items that prevent you from closing the trunk, exhaust can enter the passenger area. To avoid the possibility of **carbon monoxide poisoning**, follow the instructions on page 52 .

Air Intake

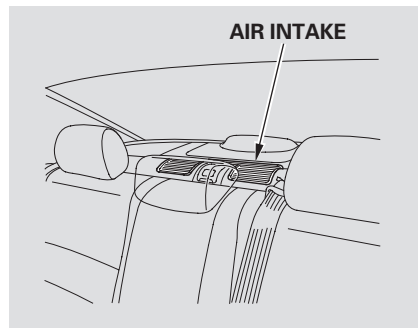

The air intake for the IMA battery and electronics is located on top of the rear shelf. Do not block this air intake; it may cause the IMA battery and the power control unit to overheat, causing the IMA system to shut down. It will start working again after it cools.

Do not spill any liquids over the air intake or put any small foreign objects in it. This may damage the IMA battery and the power control unit.

This section gives you tips on starting the engine under various conditions, and how to operate the automatic transmissions (CVT). It also includes important information on parking your vehicle and the braking system.

Preparing to Drive	164
Starting the Engine.....	165
Automatic Transmission (CVT) ..	166
Parking.....	172
Braking System.....	173
Anti-lock Brakes (ABS)	174
Towing a Trailer	175

Preparing to Drive

You should do the following checks and adjustments before you drive your vehicle.

1. Make sure all windows, mirrors, and outside lights are clean and unobstructed. Remove frost, snow, or ice.
2. Check that the hood and trunk are fully closed.
3. Visually check the tires. If a tire looks low, use a gauge to check its pressure (see page [207](#)).
4. Check that any items you may be carrying are stored properly or fastened down securely.
5. Check the seat adjustment (see page [89](#)).
6. Check the adjustment of the inside and outside mirrors (see page [93](#)).
7. Check the steering wheel adjustment (see page [75](#)).
8. Make sure the doors are securely closed and locked.
9. Fasten your seat belt. Check that your passengers have fastened their seat belts (see page [14](#)).
10. When you start the engine, check the gauges and indicators in the instrument panel (see page [57](#)).

1. Apply the parking brake.
2. In cold weather, turn off all electrical accessories to reduce the drain on the battery.
3. Make sure the shift lever is in Park. Press on the brake pedal.
4. Without touching the accelerator pedal, turn the ignition key to the START (III) position. Do not hold the key in the START (III) position for more than 15 seconds at a time. If the engine does not start right away, pause for at least 10 seconds before trying again.

NOTICE

The immobilizer system protects your vehicle from theft. If an improperly-coded key (or other device) is used, the engine's fuel system is disabled. For more information, see page 78 .

5. If the engine does not start within 15 seconds, or starts but stalls right away, repeat step 4 with the accelerator pedal pressed halfway down. If the engine starts, release pressure on the accelerator pedal so the engine does not race.
6. If the engine fails to start, press the accelerator pedal all the way down, and hold it there while starting to clear flooding. If the engine still does not start, return to step 5.

Starting in Cold Weather

In cold weather, conventional starter is used instead of the IMA system starter. This is normal.

NOTICE

The engine is harder to start in cold weather. Also, the thinner air found at altitudes above 8,000 feet (2,400 meters) adds to this problem.

Automatic Transmission (CVT)

Continuously Variable Transmission (CVT)

Honda's Continuously Variable Transmission's unique design provides a smooth, constant flow of power. It is electronically controlled for more precise operation and better fuel economy.

Shift Lever Position Indicators

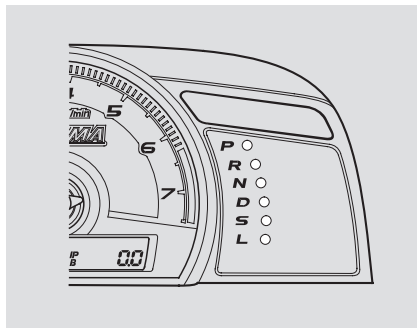

These indicators on the instrument panel show which position the shift lever is in.

The “D” indicator comes on for a few seconds when you turn the ignition switch to the ON (II) position. If it flashes while driving (in any shift position), it indicates a possible problem in the transmission.

If the malfunction indicator lamp comes on along with the “D” indicator, there is a problem with the automatic transmission control system. Avoid rapid acceleration, and have the transmission checked by your dealer as soon as possible.

Shifting

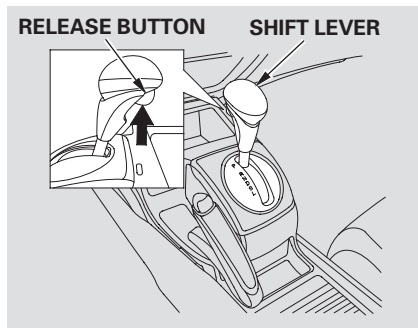

To shift from Park to any position, press firmly on the brake pedal and press the release button on the front of the shift lever, then pull the lever. You cannot shift out of Park when the ignition switch is in the LOCK (0) or the ACCESSORY (I) position.

To shift from:	Do this:
P to R	Press the brake pedal and press the release button.
R to P N to R S to L	Press the release button.
L to S S to D D to N D to S N to D R to N	Move the lever.

Park (P) – This position mechanically locks the transmission. Use Park whenever you are turning off or starting the engine. To shift out of Park, you must press on the brake pedal and have your foot off the accelerator pedal. Press the release button on the front of the shift lever to move it.

If you have done all of the above and still cannot move the lever out of Park, see **Shift Lock Release** on page 169.

You must also press the release button to shift into Park. To avoid transmission damage, come to a complete stop before shifting into Park. The shift lever must be in Park before you can remove the key from the ignition switch.

CONTINUED

Automatic Transmission (CVT)

Reverse (R) — Press the brake pedal and press the release button on the front of the shift lever to shift from Park to reverse. To shift from reverse to neutral, come to a complete stop, and then shift. Press the release button before shifting into reverse from neutral.

Neutral (N) — Use neutral if you need to restart a stalled engine, or if it is necessary to stop briefly with the engine idling. Shift to the Park position if you need to leave your vehicle for any reason. Press on the brake pedal when you are moving the shift lever from neutral to another gear.

Drive (D) — Use this position for your normal driving. The transmission automatically adjusts to keep the engine at the best speed for driving conditions. To help the engine warm up faster, the transmission will select ratios that

allow the engine to run at higher speeds when it is cold.

Second (S) — Selecting Second shifts the transmission into a lower range of ratios for better acceleration and increased engine braking. Use Second when you are going down a steep hill, or in stop-and-go driving.

Low (L) — To shift to Low, press the release button on the front of the shift lever. Use Low to get more power when climbing, and for maximum engine braking when going down steep hills.

For faster acceleration when in D, S or L, the transmission will automatically “kick down” to a lower range of ratios by pushing the accelerator pedal to the floor.

Engine Speed Limiter

When the vehicle reaches the maximum speed in any shift position, you may feel the engine cut in and out. This is caused by a limiter (112 mph, 180 km/h) in the engine's computer controls. The engine will run normally when you reduce the speed to below the maximum.

Shift Lock Release

Do this if pushing on the brake pedal and pressing the release button does not shift the transmission out of Park:

1. Set the parking brake.
2. Remove the key from the ignition switch.
3. Put a cloth on the notch of the shift lock release slot cover. Using a small flat-tipped screwdriver or a metal fingernail file, carefully pry on the notch of the cover to remove it.

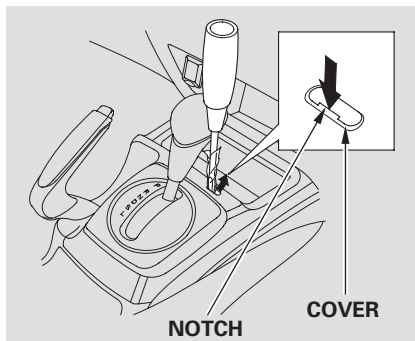

4. Insert a key into the shift lock release slot.
5. Push down on the key while you press the release button on the shift lever and move the shift lever out of Park to neutral.

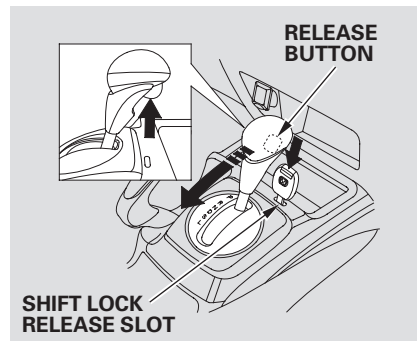

6. Remove the key from the shift lock release slot, then install the cover. Make sure the notch on the cover is on the shift lever side. Return the key to the ignition switch, press the brake pedal, and restart the engine.

If you need to use the shift lock release, it means your vehicle is developing a problem. Have it checked by your dealer.

Automatic Transmission (CVT)

Auto Idle Stop

To maximize fuel economy, your Civic Hybrid has an Auto Idle Stop function. Under certain conditions, the engine will shut off when you come to a stop. Those conditions are:

- The engine coolant is nearly up to normal operating temperature.
- The shift lever is in D or N.
- You are not pressing on the accelerator pedal.
- You are pressing on the brake pedal.
- The IMA battery is charged enough to operate the system.
- Fan speed – lower fan speeds, in either AUTO or manual modes.
- Outside temperature is between 10 – 100 degrees F.

- The front window defroster is off.

The Auto Idle Stop function activates if you speed up to over 8 mph (12 km/h) and brake to a stop. And it can activate twice even if you speed up to 8 mph (12 km/h) or below and brake to a stop.

The engine will start again when you release the brake pedal. It will also restart, even if you are still pressing the brake pedal, under these conditions:

- You move the shift lever from D or N to R or L.
- You press the accelerator pedal.
- You are on an incline, and the vehicle begins rolling.

The Auto Idle Stop function may activate when you slow down.

Auto Idle Stop Indicator

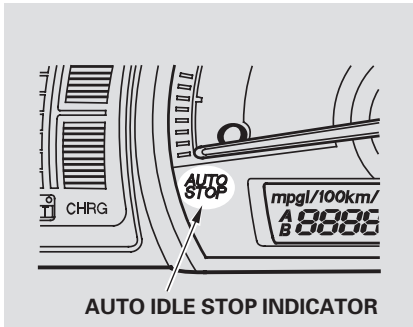

The indicator blinks as a reminder that the engine has stopped because of the Auto Idle Stop function. You cannot restart the engine with the ignition switch when this indicator is blinking.

If you open the driver's door when Auto Stop is active, the indicator will blink and you will hear a continuous beep. The beep will stop when you close the door.

With the driver's door open, you will hear a continuous beep even if the Auto Idle Stop function is deactivated and the engine restarts.

Always turn the ignition switch to the LOCK (0) position and remove the key if you are getting out of the vehicle.

Parking

Always use the parking brake when you park your vehicle. Make sure the parking brake is set firmly or your vehicle may roll if it is on an incline.

Set the parking brake before you put the transmission in Park. This keeps the vehicle from moving and putting pressure on the parking mechanism in the transmission.

Parking Tips

- Make sure the windows are closed.
- Turn off the lights.
- Place any packages, valuables, etc., in the trunk or take them with you.
- Lock the doors.

Check the indicator on the instrument panel to verify that the security system is set.

- Never park over dry leaves, tall grass, or other flammable materials. The hot three way catalytic converter could cause these materials to catch on fire.
- If the vehicle is facing uphill, turn the front wheels away from the curb.

- If the vehicle is facing downhill, turn the front wheels toward the curb.
- Make sure the parking brake is fully released before driving away. Driving with the parking brake partially set can overheat or damage the rear brakes.

NOTICE

Never install a sunshade between the upper and lower meters on the instrument panel. If you do, you could cause heat damage to the upper meter on a very hot day.

Your vehicle is equipped with front disc brakes. The brakes on the rear wheels are drum. A power assist helps reduce the effort needed on the brake pedal. The ABS helps you retain steering control when braking very hard.

Resting your foot on the brake pedal applies the brakes slightly. This builds up heat, and reduces brake effectiveness and brake pad life. In addition, fuel economy can be reduced. It also keeps your brake lights on all the time, confusing drivers behind you.

Constant application of the brakes when going down a long hill builds up heat and reduces their effectiveness. Use the engine to assist the brakes by taking your foot off the accelerator and downshifting to a lower gear.

Check the brakes after driving through deep water. Apply the brakes moderately to see if they feel normal. If not, apply them gently and frequently until they do. Be extra cautious in your driving.

Your vehicle is equipped with an advanced hydraulic booster. The advanced hydraulic booster has some features.

Power-Assist

This feature enables you to press the brake pedal with less force by the help of hydraulic pressure in the oil pressure pump.

Cooperative Control with Regenerative Brake

This feature controls the braking pressure appropriately, coordinating with the regenerating brake of the IMA motor.

Creep Aid System

When you release the brake pedal while the Auto Idle Stop function activates, this feature keeps the braking pressure until the engine starts, and prevents the vehicle from dropping back.

Brake-Assist

This feature helps you apply the brakes with less force during an emergency braking situation.

Anti-lock Brakes (ABS)

Braking System Design

The hydraulic system that operates the brakes has two separate circuits. Each circuit works diagonally across the vehicle (the left-front brake is connected with the right-rear brake, etc.). If one circuit should develop a problem, you will still have braking at two wheels.

Brake Pad Wear Indicators

If the brake pads need replacing, you will hear a distinctive, metallic screeching sound when you apply the brake pedal. If you do not have the brake pads replaced, they will screech all the time. It is normal for the brakes to occasionally squeal or squeak when you apply them.

The anti-lock brake system (ABS) helps prevent the wheels from locking up, and helps you retain steering control by pumping the brakes rapidly, much faster than a person can do it.

The electronic brake distribution (EBD) system, which is part of the ABS, also balances the front-to-rear braking distribution according to vehicle loading.

You should never pump the brake pedal. Let the ABS work for you by always keeping firm, steady pressure on the brake pedal. This is sometimes referred to as “stomp and steer.”

You will feel a pulsation in the brake pedal when the ABS activates, and you may hear some noise. This is normal: it is the ABS rapidly pumping the brakes. On dry pavement, you will need to press on the brake pedal very hard before the

ABS activates. However, you may feel the ABS activate immediately if you are trying to stop on snow or ice.



ABS Indicator

If this indicator comes on, the anti-lock function of the braking system has shut down. The brakes still work like a conventional system, but without anti-lock. You should have your dealer inspect your vehicle as soon as possible.

If the ABS indicator comes on while driving, test the brakes as shown on page [230](#).

If the ABS indicator and the brake system indicator come on together, and the parking brake is fully released, the EBD system may also be shut down.

Test your brakes as instructed on page 230. If the brakes feel normal, drive slowly and have your vehicle repaired by your dealer as soon as possible. Avoid sudden hard braking which could cause the rear wheels to lock up and possibly lead to a loss of control.

Important Safety Reminders
ABS does not reduce the time or distance it takes to stop the vehicle. It only helps with steering control during braking.

ABS will not prevent a skid that results from changing direction abruptly, such as trying to take a corner too fast or making a sudden lane change. Always drive at a safe speed for the road and weather conditions.

ABS cannot prevent a loss of stability. Always steer moderately when you are braking hard. Severe or sharp steering wheel movement can still cause your vehicle to veer into oncoming traffic or off the road.

A vehicle with ABS may require a longer distance to stop on loose or uneven surfaces, such as gravel or snow, than a vehicle without anti-lock.

Towing a Trailer

Your vehicle is not designed to tow a trailer; attempting to do so can void your warranties.

This section explains why it is important to keep your vehicle well maintained and how to follow basic maintenance safety precautions.

This section also includes instructions on how to read the maintenance minder messages on the information display, a maintenance record, and instructions for simple maintenance tasks you may want to take care of yourself.

If you have the skills and tools to perform more complex maintenance tasks on your vehicle, you may want to purchase the service manual. See page 255 for information on how to obtain a copy, or see your dealer.

Maintenance Safety	178
Maintenance Minder	179
Maintenance Record	186
Fluid Locations.....	188
Adding Engine Oil	189
Changing the Oil and Filter.....	190
Engine Coolant.....	192
Windshield Washers	194
Transmission Fluid.....	195
Continuously Variable Transmission (CVT)	195
Brake Fluid	196
Lights	197
Roof Antenna	202
Cleaning the Seat Belts.....	203
Floor Mats	203
Dust and Pollen Filter	204
Wiper Blades	205
Wheels	207
Tires	207
Checking the 12 Volt Battery.....	212
Vehicle Storage	213

Maintenance Safety

All service items not detailed in this section should be performed by a certified technician or qualified mechanic.

Important Safety Precautions

To eliminate potential hazards, read the instructions before you begin, and make sure you have the tools and skills required.

- Make sure your vehicle is parked on level ground, the parking brake is set, and the engine is off.
- To clean parts, use a commercially available degreaser or parts cleaner, not gasoline.
- To reduce the possibility of fire or explosion, keep cigarettes, sparks, and flames away from the battery and all fuel-related parts.

- Wear eye protection and protective clothing when working with the battery or compressed air.

WARNING

Improperly maintaining this vehicle or failing to correct a problem before driving can cause a crash in which you can be seriously hurt or killed.

Always follow the inspection, maintenance recommendations, and schedules in this owner's manual.

Potential Vehicle Hazards

- **Carbon Monoxide poison from engine exhaust.** Be sure there is adequate ventilation whenever you operate the engine.

- **Burns from hot parts.** Let the engine and exhaust system cool down before touching any parts.
- **Injury from moving parts.** Do not run the engine unless instructed to do so.

WARNING

Failure to properly follow maintenance instructions and precautions can cause you to be seriously hurt or killed.

Always follow the procedures and precautions in this owner's manual.

Some of the most important safety precautions are given here. However, we cannot warn you of every conceivable hazard that can arise in performing maintenance. Only you can decide whether or not you should perform a given task.

Your vehicle displays engine oil life and maintenance service items on the information display to show you when you should have your dealer perform engine oil replacement and indicated maintenance service.

Based on the engine operating conditions and accumulated engine revolutions, the onboard computer in your vehicle calculates the remaining engine oil life and displays it as a percentage.

Engine Oil Life Display

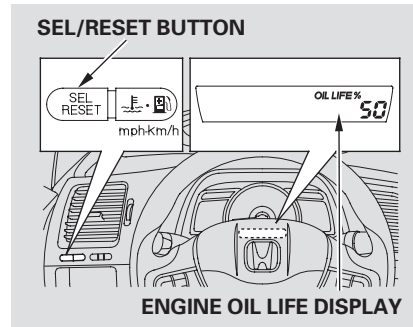

To see the current engine oil life, turn the ignition switch to the ON (II) position, and press the SEL/RESET button repeatedly until the engine oil life display appears (see [page 64](#)).

The remaining engine oil life is shown on the display according to this table:

Calculated Engine Oil Life (%)	Displayed Engine Oil Life (%)
100 % – 91 %	100 %
90 % – 81 %	90 %
80 % – 71 %	80 %
70 % – 61 %	70 %
60 % – 51 %	60 %
50 % – 41 %	50 %
40 % – 31 %	40 %
30 % – 21 %	30 %
20 % – 16 %	20 %
15 % – 11 %	15 %
10 % – 6 %	10 %
5 % – 1 %	5 %
0 %	0 %

CONTINUED

Maintenance Minder

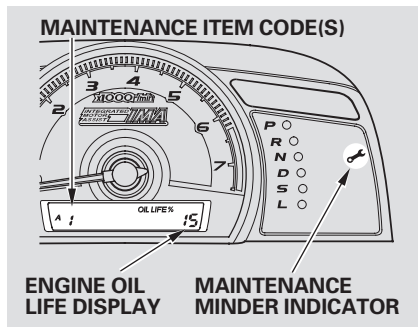

If the remaining engine oil life is 15 to 6 percent, you will see the engine oil life indicator every time you turn the ignition switch to the ON (II) position. The maintenance minder indicator will also come on, and the maintenance item code(s) for other scheduled maintenance items needing service will be displayed next to the engine oil life indicator.

The maintenance item code or codes indicate the main and sub items required at the time of the oil change (see page [185](#)).

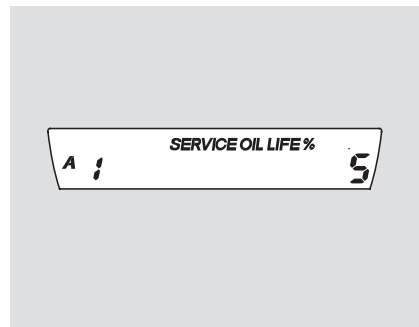

When the remaining engine oil life is 5 to 1 percent, you will see a "SERVICE OIL LIFE" message along with the same maintenance item code(s), every time you turn the ignition switch to the ON (II) position.

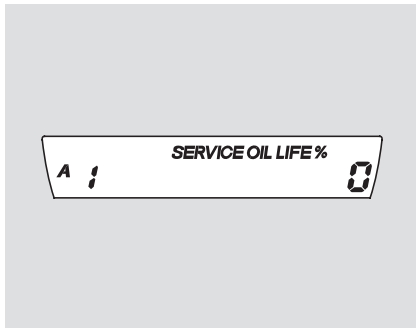

When the remaining engine oil life is 0 percent, the engine oil life indicator will blink. The display comes on every time you turn the ignition switch to the ON (II) position. When you see this message, have the indicated maintenance performed by your dealer as soon as possible.

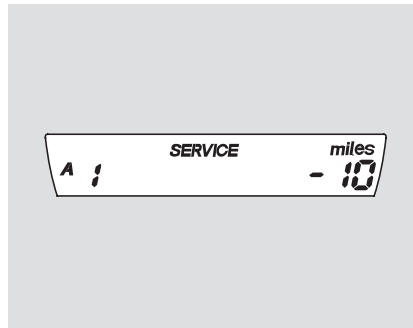

If you still do not perform the indicated maintenance, you will see negative mileage. It is displayed when you drive more than 10 miles (for U.S. models) or 10 km (for Canadian models) after seeing the 0 percent message. Afterward, it shows your driving distance if you continue to drive. Immediately have the indicated maintenance done by your dealer.

You can change the information display from the engine oil life display to the odometer, the trip meter, or the outside temperature every time you press and release the SEL/RESET button.

When the engine oil life is 0 percent or negative mileage, the maintenance minder indicator remains on even if you change the information display.

Immediately have the service done, and make sure to reset the display as described on the next page.

Maintenance Minder

Maintenance Main Items and Sub Items

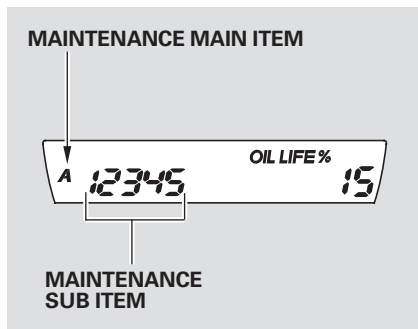

All maintenance items displayed in the information display are in code. For an explanation of these maintenance codes, see page [185](#).

Resetting the Engine Oil Life Display

Your dealer will reset the display after completing the required maintenance service. You will see “OIL LIFE 100%” on the information display the next time you turn the ignition switch to the ON (II) position.

If maintenance service is done by someone other than your dealer, reset the maintenance minder as follows:

1. Turn the ignition switch to the ON (II) position.
2. Press the SEL/RESET button repeatedly until the engine oil life is displayed.

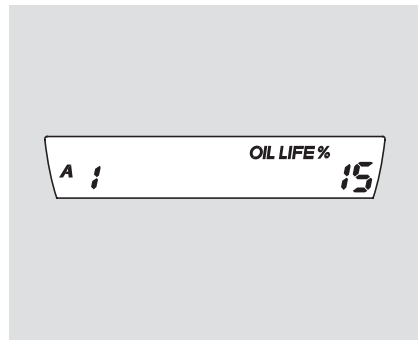

3. Press the SEL/RESET button for about 10 seconds. The engine oil life and the maintenance item code(s) will blink.



4. Press the SEL/RESET button for more than 5 seconds. The maintenance item code(s) will disappear, and the engine oil life will reset to "100."

Important Maintenance Precautions

If you have the required service done but do not reset the display, or reset the display without doing the service, the system will not show the proper maintenance intervals. This can lead to serious mechanical problems because you will no longer have an accurate record of when maintenance is needed.

Your authorized Honda dealer knows your vehicle best and can provide competent, efficient service.

However, service at a dealer is not mandatory to keep your warranties in effect. Maintenance may be done by any qualified service facility or person who is skilled in this type of automotive service. Make sure to have the service facility or person reset the display as previously described. Keep all receipts as proof of completion, and have the person who does the work fill out the maintenance record. Check your warranty booklet for more information.

We recommend using Honda parts and fluids whenever you have maintenance done. These are manufactured to the same high quality standards as the original components, so you can be confident of their performance and durability.

CONTINUED

U.S. Vehicles:

Maintenance, replacement, or repair of emissions control devices and systems may be done by any automotive repair establishment or individual using parts that are “certified” to EPA standards.

According to state and federal regulations, failure to perform maintenance on the items marked with # will not void your emissions warranties. However, all maintenance services should be performed in accordance with the intervals indicated by the information display.

Owner’s Maintenance Checks

You should check the following items at the specified intervals. If you are unsure of how to perform any check, turn to the appropriate page listed.

- Engine oil level — Check every time you fill the fuel tank. See page [153](#) .
 - Engine coolant level — Check the radiator reserve tank every time you fill the fuel tank. See page [154](#) .
 - Automatic transmission — Check the fluid level monthly. See page [195](#) .
 - Brakes — Check the fluid level monthly. See page [196](#) .
 - Tires — Check the tire pressure monthly. Examine the tread for wear and foreign objects. See page [207](#) .
- Lights — Check the operation of the headlights, parking lights, taillights, high-mount brake light, turn signals, brake lights, and license plate light monthly. See page [197](#) .

Symbol	Maintenance Main Items
A	<ul style="list-style-type: none"> ● Replace engine oil¹
B	<ul style="list-style-type: none"> ● Replace engine oil¹ and oil filter ● Inspect front and rear brakes ● Check parking brake adjustment ● Inspect these items: <ul style="list-style-type: none"> ● Tie rod ends, steering gear box, and boots ● Suspension components ● Driveshaft boots ● Brake hoses and lines (including ABS) ● All fluid levels and condition of fluids ● Exhaust system[#] ● Fuel lines and connections[#]

1 : If the message "SERVICE OIL" does not appear more than 12 months after the display is reset, change the engine oil every year.

: See information on maintenance and emissions warranty on page 183.

NOTE: ● Independent of the maintenance minder display, replace the brake fluid every 3 years.

- Inspect idle speed every 160,000 miles (256,000 km).
- Adjust the valves during services A, B, 1, 2, or 3 only if they are noisy.

Symbol	Maintenance Sub Items
1	<ul style="list-style-type: none"> ● Rotate tires
2	<ul style="list-style-type: none"> ● Replace air cleaner element If you drive in dusty conditions, replace every 15,000 miles (24,000 km). ● Replace dust and pollen filter If you drive primarily in urban areas that have high concentrations of soot in the air from industry and from diesel-powered vehicles, replace every 15,000 miles (24,000 km). ● Inspect drive belt
3	<ul style="list-style-type: none"> ● Replace transmission fluid
4	<ul style="list-style-type: none"> ● Replace spark plugs ● Inspect valve clearance
5	<ul style="list-style-type: none"> ● Replace engine coolant

Maintenance Record

You or the servicing dealer can record all completed maintenance here. When maintenance is performed, record the mileage, circle the coded item(s) completed, and write in any other non-coded items (such as brake fluid replacement) below the codes. Keep the receipts for all work done on your vehicle. Maintenance can also be recorded in your Honda service history booklet.

Mileage	Maintenance Performed	Signature
		Date
mi km	A B 1 2 3 4 5	
mi km	A B 1 2 3 4 5	
mi km	A B 1 2 3 4 5	
mi km	A B 1 2 3 4 5	
mi km	A B 1 2 3 4 5	
mi km	A B 1 2 3 4 5	
mi km	A B 1 2 3 4 5	

Mileage	Maintenance Performed	Signature
		Date
mi km	A B 1 2 3 4 5	
mi km	A B 1 2 3 4 5	
mi km	A B 1 2 3 4 5	
mi km	A B 1 2 3 4 5	
mi km	A B 1 2 3 4 5	
mi km	A B 1 2 3 4 5	
mi km	A B 1 2 3 4 5	

Mileage	Maintenance Performed							Signature
								Date
mi km	A	B	1	2	3	4	5	
mi km	A	B	1	2	3	4	5	
mi km	A	B	1	2	3	4	5	
mi km	A	B	1	2	3	4	5	
mi km	A	B	1	2	3	4	5	
mi km	A	B	1	2	3	4	5	
mi km	A	B	1	2	3	4	5	

Mileage	Maintenance Performed							Signature
								Date
mi km	A	B	1	2	3	4	5	
mi km	A	B	1	2	3	4	5	
mi km	A	B	1	2	3	4	5	
mi km	A	B	1	2	3	4	5	
mi km	A	B	1	2	3	4	5	
mi km	A	B	1	2	3	4	5	
mi km	A	B	1	2	3	4	5	

Fluid Locations

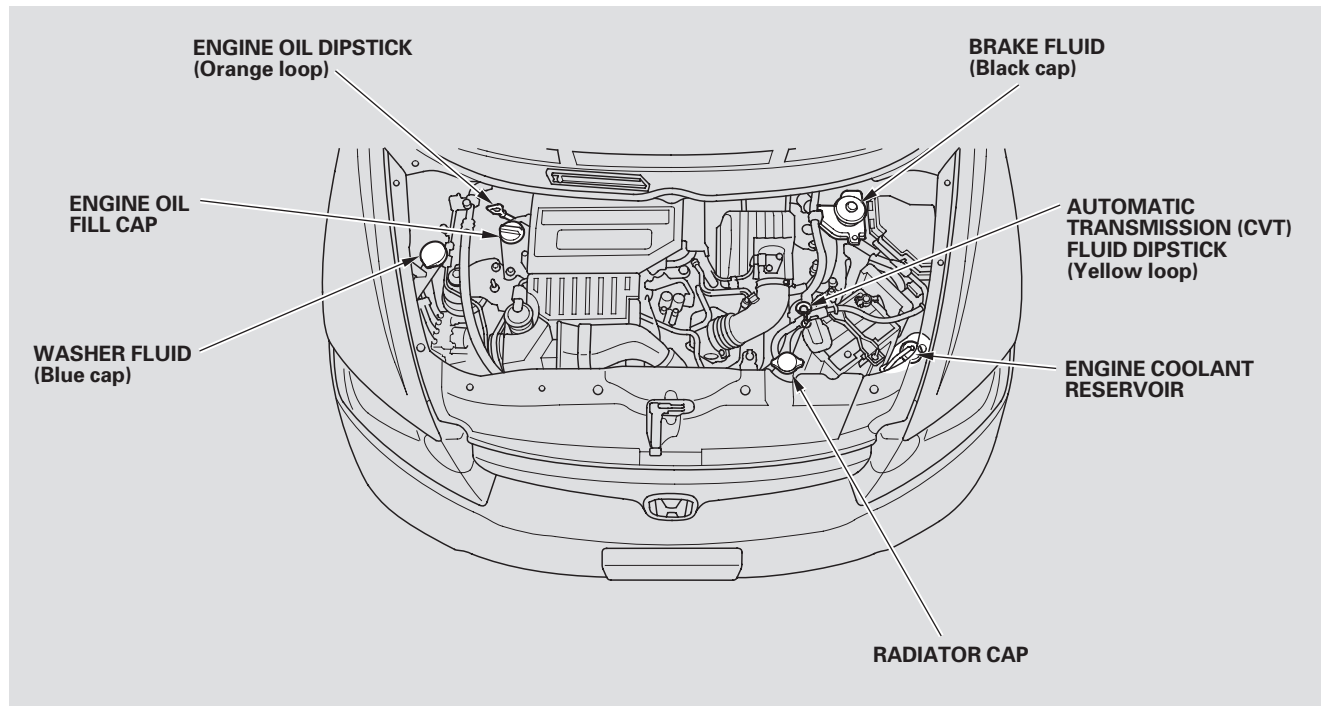

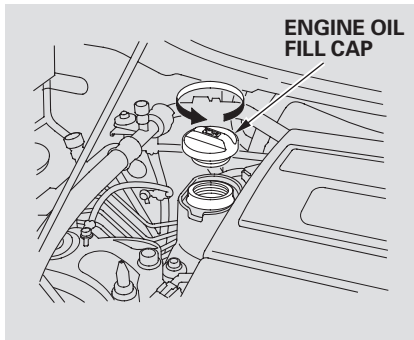

Unscrew and remove the engine oil fill cap on the valve cover. Pour in the oil slowly and carefully so you do not spill any. Clean up any spills immediately. Spilled oil could damage components in the engine compartment. Reinstall the engine oil fill cap, and tighten it securely. Wait a few minutes, and recheck the oil level on the engine oil dipstick. Do not fill above the upper mark; you could damage the engine.

Recommended Engine Oil

Oil is a major contributor to your engine's performance and longevity. Always use a premium-grade 0W-20 detergent oil displaying the API Certification Seal. This seal indicates the oil is energy conserving, and that it meets the American Petroleum Institute's latest requirements.



Honda Motor Oil is the preferred 0W-20 lubricant for your vehicle. It is highly recommended that you use Honda Motor Oil in your vehicle for

optimum engine protection. Make sure the API Certification Seal says "For Gasoline Engines".

The oil viscosity or weight is provided on the container's label.

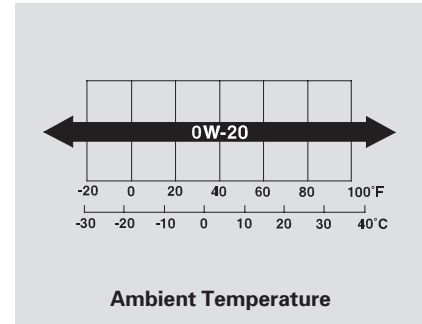

A very low-viscosity, fuel-efficient 0W-20 oil is the preferred engine lubricant for your Civic Hybrid. This special oil is formulated to help your engine use less fuel. It is available at your dealer. A 5W-20 oil may be used if 0W-20 is not available.

Adding Engine Oil, Changing the Oil and Filter

Synthetic Oil

You may use a synthetic motor oil if it meets the same requirements given for a conventional motor oil: it displays the API certification seal, and it is the proper weight. You must follow the oil and filter change intervals shown on the information display.

Engine Oil Additives

Your vehicle does not require any oil additives. Additives may adversely affect the engine or transmission performance and durability.

Changing the Oil and Filter

Always change the oil and filter according to the maintenance messages shown on the information display. The oil and filter collect contaminants that can damage your engine if they are not removed regularly.

Changing the oil and filter requires special tools and access from underneath the vehicle. The vehicle should be raised on a service station-type hydraulic lift for this service. Unless you have the knowledge and proper equipment, you should have this maintenance done by a skilled mechanic.

1. Run the engine until it reaches normal operating temperature, then shut it off.
2. Open the hood, and remove the engine oil fill cap.

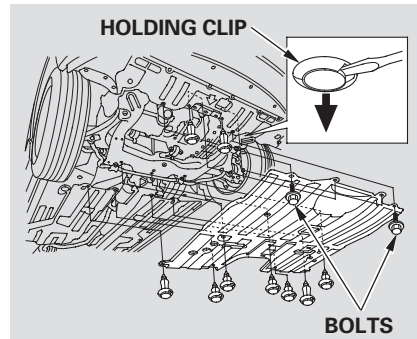

3. *Only on U.S. models*
Remove the nine holding clips with a flat-tipped screwdriver and two bolts, then pull the under-cover down.

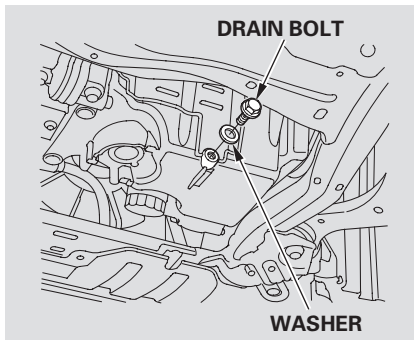

4. Remove the oil drain bolt and washer from the bottom of the engine. Drain the oil into an appropriate container.

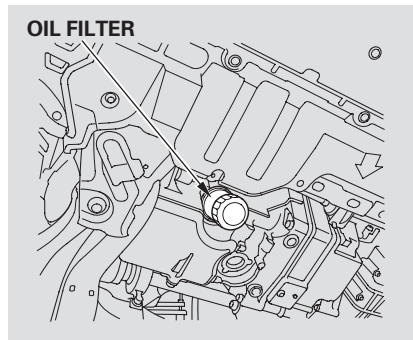

5. Remove the oil filter, and let the remaining oil drain. A special wrench (available from your dealer) is required.

Make sure the oil filter gasket is not stuck to the engine block. If it is, remove it before installing a new oil filter.

6. Install a new oil filter according to the instructions that come with it.

7. Put a new washer on the drain bolt, then reinstall the drain bolt. Tighten the drain bolt to:

29 lbf-ft (39 N·m , 4.0 kgf·m)

8. Refill the engine with the recommended oil.

Engine oil change capacity (including filter):

3.4 US qt (3.2 ℓ)

9. Reinstall the engine oil fill cap. Start the engine. The oil pressure indicator should go out within 5 seconds. If it does not, turn off the engine, and check your work.
10. Let the engine run for several minutes, then check the drain bolt and oil filter for leaks.

CONTINUED

Changing the Oil and Filter, Engine Coolant

11. Turn off the engine, let it sit for several minutes, then check the oil level on the dipstick. If necessary, add more oil.
12. *Only on U.S. models*
Put the under-cover back in place and reinstall the nine holding clips. Lock the clips securely by pushing on the center of each clip.

NOTICE

Improper disposal of engine oil can be harmful to the environment. If you change your own oil, please dispose of the used oil properly. Put it in a sealed container and take it to a recycling center. Do not discard it in a trash bin or dump it on the ground.

Adding Engine Coolant



If the coolant level in the reserve tank is at or below the MIN line, add coolant to bring it up to between the MIN and MAX lines. Inspect the cooling system for leaks.

Always use Honda Long-Life Antifreeze/Coolant Type 2. This coolant is pre-mixed with 50 % antifreeze and 50 % water. Never add straight antifreeze or plain water.

If Honda antifreeze/coolant is not available, you may use another major-brand non-silicate coolant as a temporary replacement. Make sure it is a high-quality coolant recommended for aluminum engines. Continued use of any non-Honda coolant can result in corrosion, causing the cooling system to malfunction or fail. Have the cooling system flushed and refilled with Honda antifreeze/coolant as soon as possible.

If the reserve tank is completely empty, you should also check the coolant level in the radiator.

⚠ WARNING

Removing the radiator cap while the engine is hot can cause the coolant to spray out, seriously scalding you.

Always let the engine and radiator cool down before removing the radiator cap.

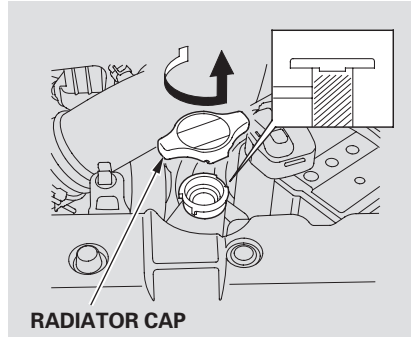

1. Make sure the engine and radiator are cool.
2. Relieve any pressure in the cooling system by turning the radiator cap counterclockwise, without pressing down.
3. Remove the radiator cap by pushing down and turning counterclockwise.

4. The coolant level should be up to the base of the filler neck. Add coolant if it is low.

Pour the coolant slowly and carefully so you do not spill any. Clean up any spill immediately; it could damage components in the engine compartment.

5. Put the radiator cap back on, and tighten it fully.

6. Pour coolant into the reserve tank. Fill it to halfway between the MAX and MIN marks. Put the cap back on the reserve tank.

Do not add any rust inhibitors or other additives to your vehicle's cooling system. They may not be compatible with the coolant or engine components.

Windshield Washers

Check the fluid level in the windshield washer reservoir at least monthly during normal use.

On Canadian models: The low washer level indicator comes on when the level is low (see page [61](#)).

Check the fluid level by removing the cap and looking at the level gauge.

Fill the reservoir with a good-quality windshield washer fluid. This increases the cleaning capability and prevents freezing in cold weather.

When you refill the reservoir, clean the edges of the windshield wiper blades with windshield washer fluid on a clean cloth. This will help to condition them.

NOTICE

Do not use engine antifreeze or a vinegar/water solution in the windshield washer reservoir. Antifreeze can damage your vehicle's paint, while a vinegar/water solution can damage the windshield washer pump. Use only commercially-available windshield washer fluid.

Continuously Variable Transmission (CVT)

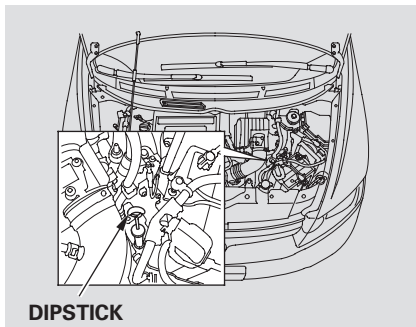

Check the fluid level with the engine at normal operating temperature.

1. Park the vehicle on level ground. Start the engine and let it run until the radiator fan comes on, then shut off the engine. For accurate results, wait about 60 seconds before going to step 2, but don't wait longer than 90 seconds.

2. Remove the dipstick (yellow loop) from the transmission, and wipe it with a clean cloth.
3. Insert the dipstick all the way into the transmission securely as shown in the illustration.

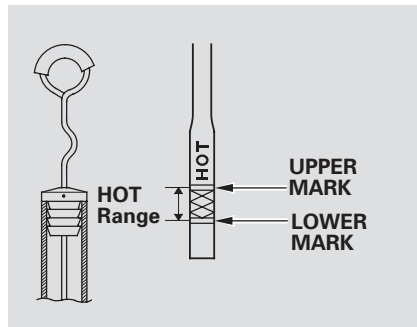

4. Remove the dipstick and check the fluid level. It should be between the upper and lower marks within the HOT range.

5. If the level is below the lower mark, add fluid into the dipstick hole to bring it to the level between the upper and lower marks.

Pour the fluid slowly and carefully so you do not spill any. Clean up any spill immediately; it could damage components in the engine compartment.

Always use Honda CVT Fluid (Continuously Variable Transmission fluid).

CONTINUED

Transmission Fluid, Brake Fluid

To thoroughly flush the transmission, the technician should drain and refill it with Honda CVT fluid, then drive the vehicle for a short distance. Do this three times. Then drain and refill the transmission a final time.

6. Insert the dipstick all the way back into the transmission securely.

The transmission should be drained and refilled with new fluid when this service is indicated by a maintenance message on the information display.

If you are not sure how to add fluid, contact your dealer.

Brake Fluid

Check the brake fluid level in the reservoirs monthly.

Replace the brake fluid every 3 years, independent of mileage.

Always use Honda Heavy Duty Brake Fluid DOT 3. If it is not available, you should use only DOT 3 or DOT 4 fluid, from a sealed container, as a temporary replacement.

Using any non-Honda brake fluid can cause corrosion and decrease the life of the system. Have the brake system flushed and refilled with Honda Heavy Duty Brake Fluid DOT 3 as soon as possible.

Brake fluid marked DOT 5 is not compatible with your vehicle's braking system and can cause extensive damage.

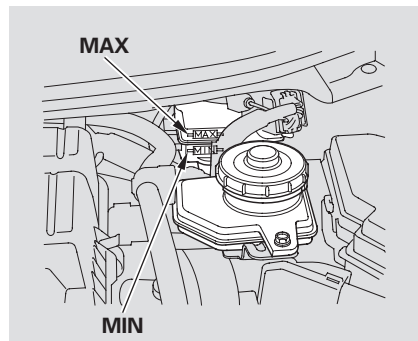

The fluid level should be between the MIN and MAX marks on the side of the reservoir. If the level is at or below the MIN mark, your brake system needs attention. Have the brake system inspected for leaks or worn brake pads/shoes.

Headlight Aiming

The headlights were properly aimed when your vehicle was new. If you regularly carry heavy items in the trunk, readjustment may be required. Adjustment should be done by your dealer or other qualified mechanic.

Replacing a Headlight Bulb

Your vehicle has halogen headlight bulbs. When replacing a bulb, handle it by its base, and protect the glass from contact with your skin or hard objects. If you touch the glass, clean it with denatured alcohol and a clean cloth.

NOTICE

Halogen headlight bulbs get very hot when lit. Oil, perspiration, or a scratch on the glass can cause the bulb to overheat and shatter.

High Beam Headlight

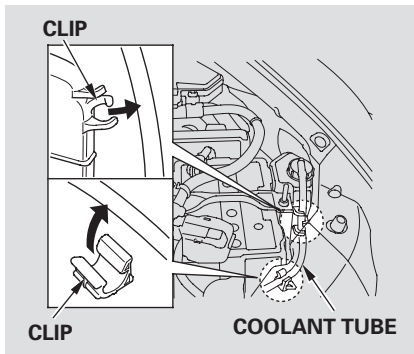

1. Open the hood.
To change a bulb on the left side, remove the coolant tube from the two clips.

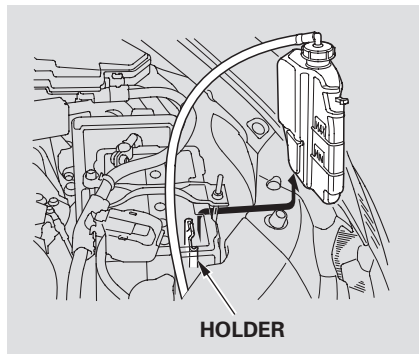

- Remove the reserve tank from its holder by pulling it straight up.

CONTINUED

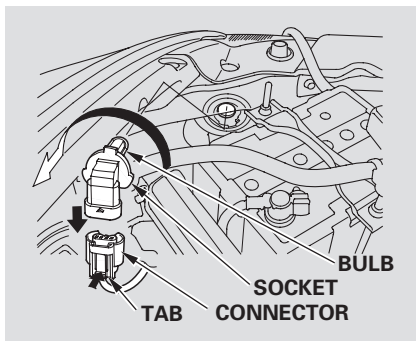

2. Remove the bulb from the headlight assembly by turning it one-quarter turn counterclockwise.
3. Remove the electrical connector from the socket by pushing on the tab and pulling the connector down.

4. Push the electrical connector back onto the bulb. Make sure it is on all the way.
5. Install the new bulb, and turn it one-quarter turn clockwise to lock it in place.
6. Turn on the headlights to test the new bulb.
7. If you replaced a headlight bulb on the driver's side, reinstall the engine coolant reserve tank.

Low Beam Headlight

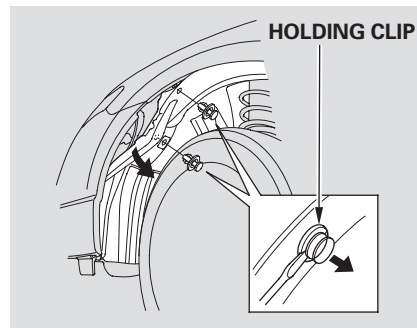

1. To change the bulb on the driver's side, start the engine, turn the steering wheel all the way to the right, then turn off the engine. To change the bulb on the passenger's side, turn the steering wheel to the left.
2. Use a flat-tipped screwdriver to remove the two holding clips from the inner fender, and pull the inner fender cover back.

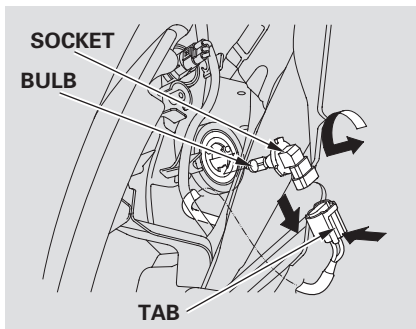

3. Remove the bulb from the headlight assembly by turning it one-quarter turn counterclockwise.
4. Remove the electrical connector from the socket by pushing on the tab and pulling the connector down.

5. Install the new bulb, and turn it one-quarter turn clockwise to lock it in place.
6. Push the electrical connector back onto the bulb. Make sure it is on all the way.
7. Turn on the headlights to test the new bulb.
8. Reinstall the inner fender cover. Then reinstall the holding clips, and lock them in place by pushing on their centers.

Replacing the Front Side Marker/ Turn Signal Light Bulb

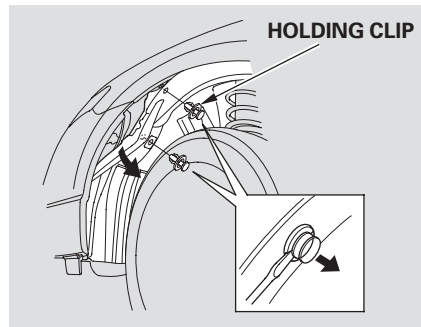

1. To change the bulb on the driver's side, start the engine, turn the steering wheel all the way to the right, then turn off the engine. To change the bulb on the passenger's side, turn the steering wheel to the left.

CONTINUED

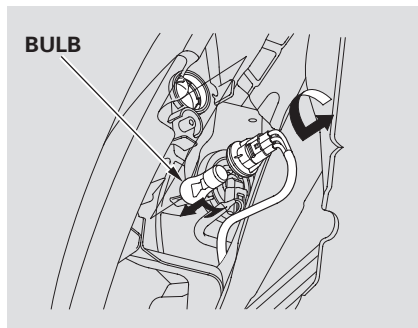

2. Use a flat-tipped screwdriver to remove the two holding clips from the inner fender, and pull the inner fender cover back.
3. Remove the bulb from the headlight assembly by turning it one-quarter turn counterclockwise.

4. Remove the bulb from the socket by pushing the bulb in and turning it counterclockwise until it unlocks.
5. Install the new bulb in the socket. Turn it clockwise to lock it in place.
6. Insert the socket back into the headlight assembly. Turn it clockwise to lock it in place.
7. Turn on the lights to make sure the new bulb is working.
8. Reinstall the inner fender cover. Then reinstall the holding clips, and lock them in place by pushing on their centers.

Replacing Rear Bulbs (In Fenders)

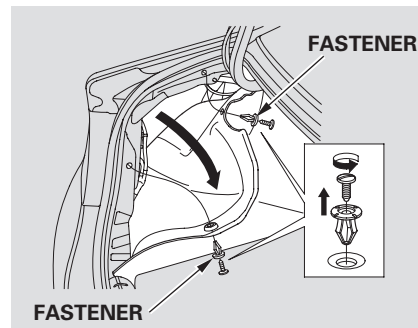

1. Open the trunk. Use the flat-tipped screwdriver to remove the screws in the center of each fastener on the side of the boot lining. Remove the fasteners first, then pull the lining back carefully.
2. Determine which of the four bulbs is burned out: stop/tail-light, back-up light, side marker light, or turn signal light.

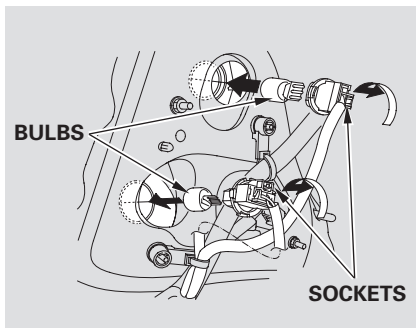

3. Remove the socket by turning it one-quarter turn counterclockwise.
4. Pull the bulb straight out of its socket. Push the new bulb straight into the socket until it bottoms.
5. Reinstall the socket into the light assembly by turning it clockwise until it locks.

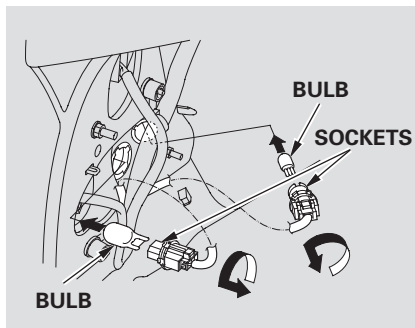

6. Turn on the lights to make sure the new bulb is working.
7. Reinstall the trunk lining. Make sure it is installed under the edge of the trunk seal.
8. Put the fasteners into the holes on the side of the trunk lining. Reinstall the screws.

Replacing Rear Bulbs (in Trunk Lid)

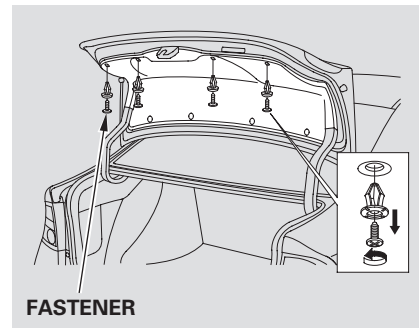

1. Open the trunk.

Use the Phillips-head screwdriver to remove the screws in the center of each fastener on the back of the boot lid. Remove the fasteners first, then pull the lining back carefully.

CONTINUED

Lights, Roof Antenna

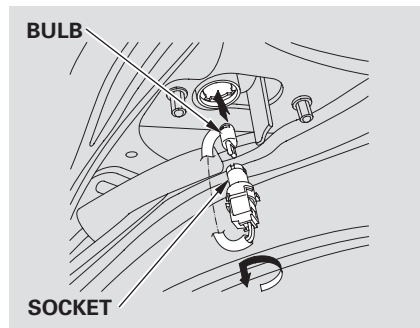

2. Remove the socket by turning it one-quarter turn counterclockwise.

3. Pull the bulb straight out of its socket. Push the new bulb straight into the socket until it bottoms.

4. Insert the socket back into the light assembly. Turn it clockwise to lock it in place.

5. Turn on the lights to make sure the new bulb is working.

6. Push the trunk lid trim back into position.

7. Put the fasteners into the holes on the trunk lid trim. Reinstall the screws.

Roof Antenna

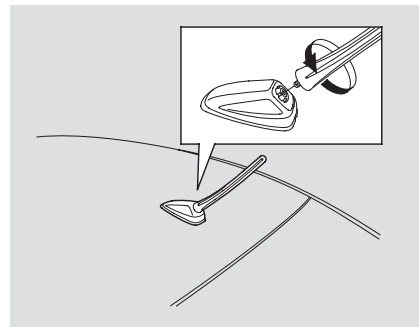

Before using an automatic car wash, remove the radio antenna so it does not get damaged. Remove the antenna by unscrewing it. When you reinstall the antenna, tighten it securely.

Before entering or parking in areas with low ceiling height, remove the antenna.

Seat Belts

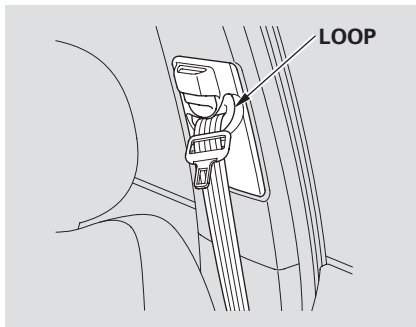

If your seat belts get dirty, use a soft brush with a mixture of mild soap and warm water to clean them. Do not use bleach, dye, or cleaning solvents. Let the belts air dry before you use the vehicle.

Dirt build-up in the loops of the seat belt anchors can cause the belts to retract slowly. Wipe the insides of the loops with a clean cloth dampened in mild soap and warm water or isopropyl alcohol.

Floor Mats

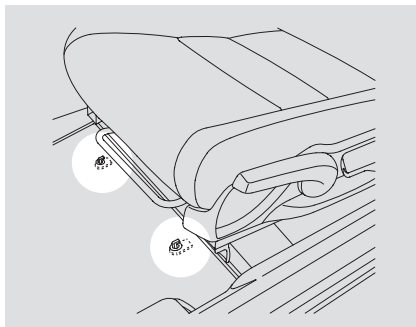

If equipped

The floor mats that came with your vehicle hooks over the floor mat anchors. This keeps the floor mat from sliding forward and possibly interfering with the pedals.

If you remove the driver's floor mat, make sure to re-anchor it when you put it back in your vehicle.

If you use non-Honda floor mats, make sure they fit properly and that they can be used with the floor mat anchors. Do not put additional floor mats on top of the anchored mats.

CONTINUED

Dust and Pollen Filter, Wiper Blades

Dust and Pollen Filter

This filter removes the dust and pollen that is brought in from the outside through the heating and cooling system/climate control system.

Have your dealer replace the filter when this service is indicated by a maintenance message on the information display. It should be replaced every 15,000 miles (24,000 km) if you drive primarily in urban areas that have high concentrations of soot in the air, or if the flow from the heating and cooling system becomes less than usual.

Wiper Blades

Check the condition of the wiper blades at least every 6 months. Replace them if you find signs of cracking in the rubber, and areas that are getting hard or if they leave streaks and unwiped areas when used.

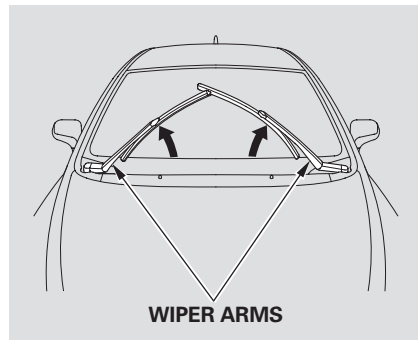

To replace a wiper blade:

1. Raise each wiper arm off the windshield, lifting the driver's side first, then the passenger's side.

NOTICE

Do not open the hood when the wiper arms are raised, or you will damage the hood and wiper arms.

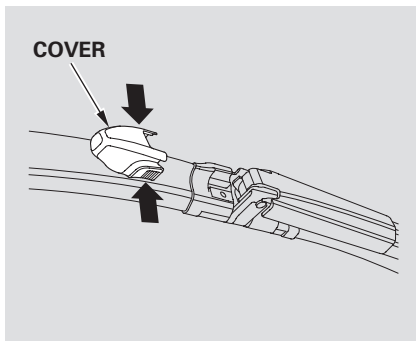

2. Remove the cover, by squeezing the two tabs and pulling it straight out.

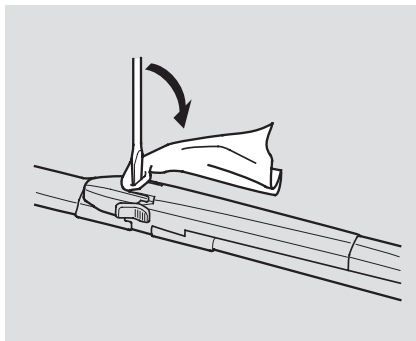

- As shown above, cover the tip of a flat-tipped screwdriver with a cloth and move the screwdriver in the direction of the arrow.

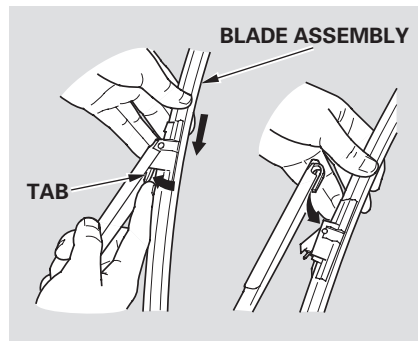

3. Disconnect the blade assembly from the wiper arm:
 - Press and hold the lock tab.
 - Slide the blade assembly toward the lock tab until it releases from the wiper arm.

When replacing a wiper blade, make sure not to drop the wiper blade or wiper arm down on the windshield.

CONTINUED

Wiper Blades

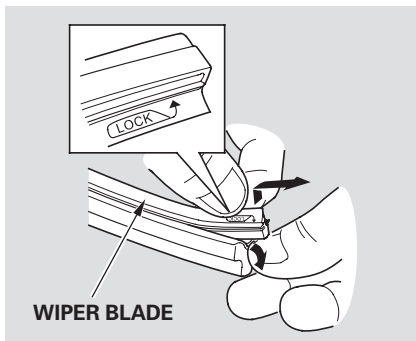

4. Remove the blade from the blade assembly:
 - Find the side of the blade labeled "LOCK." This is the side you pull out.
 - Pull back the end of the blade assembly on the "LOCK" side of the blade. Then grab the end of the blade, and slide it out.

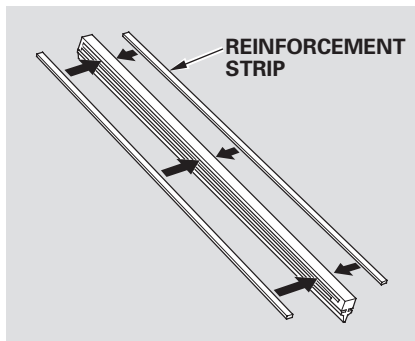

5. Examine the new wiper blades. If they have no plastic or metal reinforcement along the back edge, remove the metal reinforcement strips from the old wiper blade, and install them in the slots along the edge of the new blade.

6. Install the new blade onto the blade assembly:
 - Pull back either end of the blade assembly.
 - Place the side of the blade not labeled "LOCK" on the end of the blade assembly, and slide the blade onto the assembly until it is fully installed.
7. Slide the wiper blade assembly onto the wiper arm. Make sure it locks in place.
8. Reinstall the cover onto the blade assembly.
9. Make sure the blade is completely installed and that its edge is not bunched up.
10. Lower the wiper arm down against the windshield, the passenger's side first, then the driver's side.

Wheels

Clean the wheels as you would the rest of the exterior. Wash them with the same solution, and rinse them thoroughly.

Aluminum alloy wheels have a protective clear-coat that keeps the aluminum from corroding and tarnishing. Cleaning the wheels with harsh chemicals (including some commercial wheel cleaners) or a stiff brush can damage the clear-coat. To clean the wheels, use a mild detergent and a soft brush or sponge.

Tires

To safely operate your vehicle, your tires must be the proper type and size, in good condition with adequate tread, and correctly inflated.

The following pages give more detailed information on how to take care of your tires and what to do when they need to be replaced.

WARNING

Using tires that are excessively worn or improperly inflated can cause a crash in which you can be seriously hurt or killed.

Follow all instructions in this owner's manual regarding tire inflation and maintenance.

Inflation Guidelines

Keeping the tires properly inflated provides the best combination of handling, tread life, and riding comfort.

- Underinflated tires wear unevenly, adversely affect handling and fuel economy, and are more likely to fail from being overheated.
- Overinflated tires can make your vehicle ride more harshly, are more prone to damage from road hazards, and wear unevenly.

We recommend that you visually check your tires every day. If you think a tire might be low, check it immediately with a tire gauge.

Tires

Use a gauge to measure the air pressure in each tire at least once a month. Even tires that are in good condition may lose 1 to 2 psi (10 to 20 kPa, 0.1 to 0.2 kgf/cm²) per month. Remember to check the spare tire at the same time.

Check the air pressures when the tires are cold. This means the vehicle has been parked for at least 3 hours, or driven less than 1 mile (1.6 km). Add or release air, if needed, to match the recommended cold tire pressures.

If you check air pressures when the tires are hot [driven for several miles (kilometers)], you will see readings 4 to 6 psi (30 to 40 kPa, 0.3 to 0.4 kgf/cm²) higher than the cold readings. This is normal. Do not let air out to match the recommended cold air pressure. The tire will be underinflated.

You should get your own tire pressure gauge and use it whenever you check your tire pressures. This will make it easier for you to tell if a pressure loss is due to a tire problem and not due to a variation between gauges.

While tubeless tires have some ability to self-seal if they are punctured, you should look closely for punctures if a tire starts losing pressure.

Recommended Tire Pressures

The following chart shows the recommended cold tire pressures for most normal driving conditions.

Tire Size	Cold Tire Pressure
P195/65R15 89S	Front/Rear: 32 psi (220 kPa , 2.2 kgf/cm ²)

The compact spare tire pressure is: 60 psi (420 kPa , 4.2 kgf/cm²)

See page [243](#) or refer to the tire placard on the driver's doorjamb for correct tire pressure.

For convenience, the recommended tire sizes and cold tire pressures are on a label on the driver's doorjamb.

Tire Inspection

Every time you check inflation, you should also examine the tires for damage, foreign objects, and wear.

You should look for:

- Bumps or bulges in the tread or side of the tire. Replace the tire if you find either of these conditions.
- Cuts, splits, or cracks in the side of the tire. Replace the tire if you can see fabric or cord.
- Excessive tread wear.

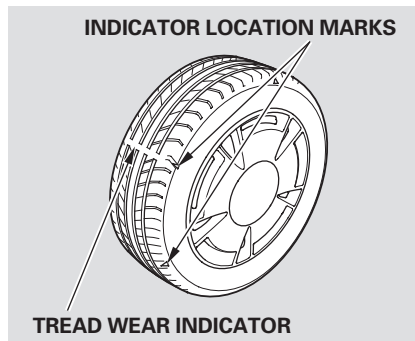

Your tires have wear indicators molded into the tread. When the tread wears down, you will see a 1/2 inch (12.7 mm) wide band across the tread. This shows there is less than 1/16 inch (1.6 mm) of tread left on the tire.

A tire this worn gives very little traction on wet roads. You should replace the tire if you can see three or more tread wear indicators.

Tire Maintenance

In addition to proper inflation, correct wheel alignment helps to decrease tire wear. If you find a tire is worn unevenly, have your dealer check the wheel alignment.

Have your dealer check the tires if you feel a consistent vibration while driving. A tire should always be rebalanced if it is removed from the wheel. When you have new tires installed, make sure they are balanced. This increases riding comfort and tire life. For best results, have the installer perform a dynamic balance.

NOTICE

Improper wheel weights can damage your vehicle's aluminum wheels. Use only Honda wheel weights for balancing.

Tires

Tire Rotation

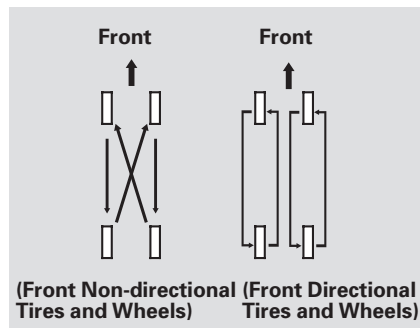

To help increase tire life and distribute wear more evenly, rotate the tires according to the maintenance messages displayed on the information display. Move the tires to the positions shown in the chart each time they are rotated. If you purchase directional tires, rotate only front-to-back.

Replacing Tires and Wheels

Replace your tires with radial tires of the same size, load range, speed rating, and maximum cold tire pressure rating (as shown on the tire's sidewall).

Mixing radial and bias-ply tires on your vehicle can reduce braking ability, traction, and steering accuracy. Using tires of a different size or construction can cause the ABS to work inconsistently.

It is best to replace all four tires at the same time. If that is not possible or necessary, replace the two front tires or two rear tires as a pair. Replacing just one tire can seriously affect your vehicle's handling.

The ABS works by comparing the speed of the wheels. When replacing tires, use the same size originally supplied with the vehicle. Tire size and construction can affect wheel

speed and may cause the system to activate.

If you ever replace a wheel, make sure the new one matches the specifications of the original. Replacement wheels are available at your dealer.

WARNING

Installing improper tires on your vehicle can affect handling and stability. This can cause a crash in which you can be seriously hurt or killed.

Always use the size and type of tires recommended in this owner's manual.

Wheel and Tire Specifications

Wheels:

15 x 6 J

Tires:

P195/65R15 89S

See page 244 for DOT tire quality grading information, and page 246 for tire size information.

Winter Driving

Tires marked “M + S” or “All Season” on the sidewall have an all-weather tread design suitable for most winter driving conditions.

For the best performance in snowy or icy conditions, you should install snow tires or tire chains. They may be required by local laws under certain conditions.

Snow Tires

If you mount snow tires on your vehicle, make sure they are radial tires of the same size and load range as original tires. Mount snow tires on all four wheels. The traction provided by snow tires on dry roads may be lower than your original tires. Check with the tire dealer for maximum speed recommendations.

Tire Chains

Because your vehicle has limited tire clearance, mount only SAE Class “S” cable-type traction devices, with rubber chain tensioners, on the front tires. Use traction devices only when required by driving conditions or local laws. Make sure they are the correct size for your tires. Metal link-type “chains” should not be used.

When installing cables, follow the manufacturer’s instructions, and mount them as tight as you can. Make sure they are not contacting the brake lines or suspension. Drive slowly with them installed. If you hear them coming into contact with the body or chassis, stop and investigate. Remove them as soon as you begin driving on cleared roads.

NOTICE

Traction devices that are the wrong size or improperly installed can damage your vehicle’s brake lines, suspension, body, and wheels. Stop driving if they are hitting any part of the vehicle.

Checking the 12 Volt Battery

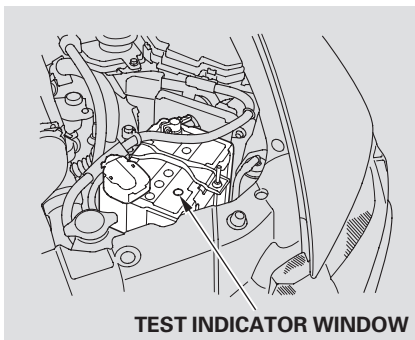

Check the condition of the 12 volt battery monthly by looking at the test indicator window. The label on the battery explains the test indicator's colors.

Check the terminals for corrosion (a white or yellowish powder). To remove it, cover the terminals with a solution of baking soda and water. It will bubble up and turn brown. When this stops, wash it off with plain water. Dry off the battery with a cloth or paper towel. Coat the terminals with grease to help prevent further corrosion.

If additional battery maintenance is needed, see your dealer or a qualified technician.

WARNING: Battery posts, terminals, and related accessories contain lead and lead compounds. **Wash your hands after handling.**

If you need to connect the battery to a charger, disconnect both cables to prevent damaging your vehicle's electrical system. Always disconnect the negative (–) cable first, and reconnect it last.

⚠ WARNING

The battery gives off explosive hydrogen gas during normal operation.

A spark or flame can cause the battery to explode with enough force to kill or seriously hurt you.

Wear protective clothing and a face shield, or have a skilled technician do the battery maintenance.

If your vehicle's 12 volt battery is disconnected or goes dead, the IMA battery level gauge reading will not be correct the next time you turn the ignition switch to the ON (II) position. It will show less than the actual level temporarily. It will show the correct level after you drive for at least 30 minutes.

If you need to park your vehicle for an extended period (more than 1 month), there are several things you should do to prepare it for storage. Proper preparation helps prevent deterioration and makes it easier to get your vehicle back on the road. If possible, store your vehicle indoors.

- Fill the fuel tank.
- Change the engine oil and filter.
- Wash and dry the exterior completely.
- Clean the interior. Make sure the carpeting, floor mats, etc., are completely dry.
- Leave the parking brake off. Put the transmission in Park.

- Block the rear wheels.
- If the vehicle is to be stored for a longer period, it should be supported on jackstands so the tires are off the ground.
- Leave one window open slightly (if the vehicle is being stored indoors).
- Disconnect the 12 volt battery.
- Support the front wiper blade arms with a folded towel or rag so they do not touch the windshield.
- To minimize sticking, apply a silicone spray lubricant to all door and trunk seals. Also, apply a vehicle body wax to the painted surfaces that mate with the door and trunk seals.

- Cover the vehicle with a “breathable” cover, one made from a porous material such as cotton. Non-porous materials, such as plastic sheeting, trap moisture, which can damage the paint.
- Reconnect the 12 volt battery and drive your vehicle every month for about 30 minutes. This will keep the IMA battery charged and in good condition.
- If possible, periodically run the engine until it reaches full operating temperature (the cooling fans cycle on and off twice). Preferably, do this once a month.

NOTICE

If this vehicle is unused for over one month, the service life of the 158V Nickel-Metal Hydride battery will be reduced and the battery may be permanently damaged.

This section covers the more common problems that motorists experience with their vehicles. It gives you information about how to safely evaluate the problem and what to do to correct it. If the problem has stranded you on the side of the road, you may be able to get going again. If not, you will also find instructions on getting your vehicle towed.

Compact Spare Tire.....	216
Changing a Flat Tire	217
If the Engine Won't Start.....	221
Jump Starting	223
If the Engine Overheats	225
Low Oil Pressure Indicator	227
Charging System Indicator.....	228
Malfunction Indicator Lamp	229
Brake System Indicator	230
Fuses	231
Fuse Locations.....	235
Emergency Towing	237

Compact Spare Tire

Use the compact spare tire as a temporary replacement only. Get your regular tire repaired or replaced, and put it back on your vehicle as soon as you can.

Check the inflation pressure of the compact spare tire every time you check the other tires. It should be inflated to:
60 psi (420 kPa , 4.2 kgf/cm²)

Follow these precautions:

- Never exceed 50 mph (80 km/h).
- This tire gives a harsher ride and less traction on some road surfaces. Use greater caution while driving.
- Do not mount snow chains on the compact spare tire.
- Do not use your compact spare tire on another vehicle unless it is the same make and model.

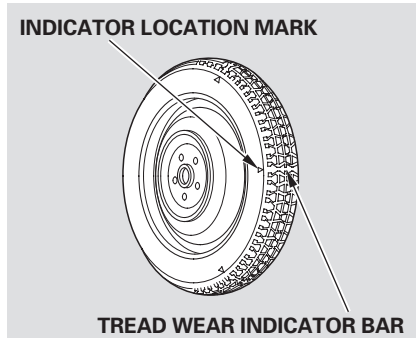

Replace the tire when you can see the tread wear indicator bars. The replacement should be the same size and design tire, mounted on the same wheel. The spare tire is not designed to be mounted on a regular wheel, and the spare wheel is not designed for mounting a regular tire.

If you have a flat tire while driving, stop in a safe place to change it. Drive slowly along the shoulder until you get to an exit or an area to stop that is far away from the traffic lanes.

⚠️ WARNING

The vehicle can easily roll off the jack, seriously injuring anyone underneath.

Follow the directions for changing a tire exactly, and never get under the vehicle when it is supported only by the jack.

1. Park the vehicle on firm, level, and non-slippery ground. Put the transmission in Park. Apply the parking brake.
2. Turn on the hazard warning lights, and turn the ignition switch to the LOCK (0) position. Have all passengers get out of the vehicle while you change the tire.

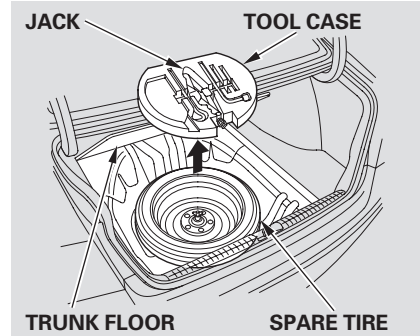

3. Open the trunk. Raise the trunk floor by lifting up on the back edge.
4. Take the tool case out of the spare tire.
5. Unscrew the wing bolt and take the spare tire out of its well.

CONTINUED

Changing a Flat Tire

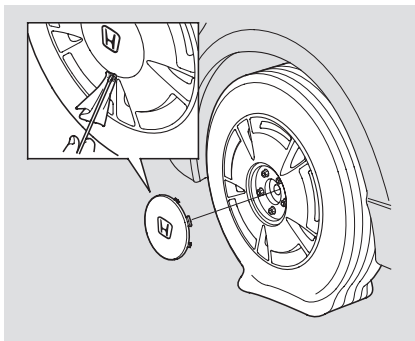

6. Remove the center cap from the wheel with the extension.

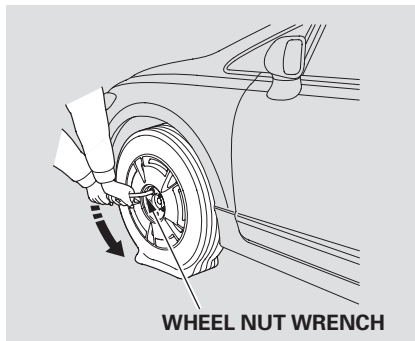

7. Loosen each wheel nut 1/2 turn with the wheel nut wrench.

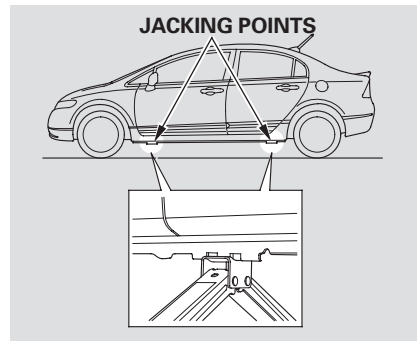

8. Place the jack under the jacking point nearest the tire you need to change. Turn the end bracket clockwise until the top of the jack contacts the jacking point. Make sure the jacking point tab is resting in the jack notch.

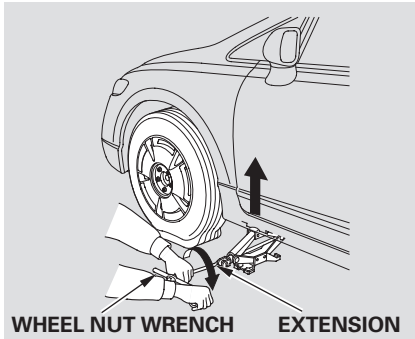

9. Use the extension and the wheel nut wrench as shown to raise the vehicle until the flat tire is off the ground.
10. Remove the wheel nuts, then remove the flat tire. Handle the wheel nuts carefully; they may be hot from driving. Place the flat tire on the ground with the outside surface facing up.

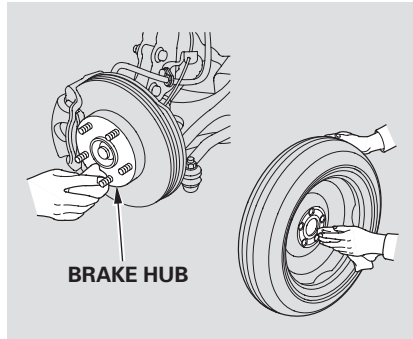

11. Before mounting the spare tire, wipe any dirt off the mounting surface of the wheel and hub with a clean cloth. Wipe the hub carefully; it may be hot from driving.

12. Put on the spare tire. Put the wheel nuts back on finger-tight, then tighten them in a crisscross pattern with the wheel nut wrench until the wheel is firmly against the hub. Do not try to tighten the wheel nuts fully.
13. Lower the vehicle to the ground, and remove the jack.

CONTINUED

Changing a Flat Tire

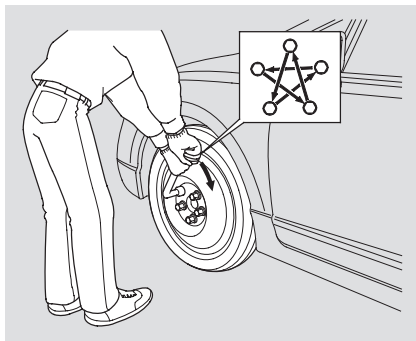

14. Tighten the wheel nuts securely in the same crisscross pattern. Have the wheel nut torque checked at the nearest automotive service facility.
Tighten the wheel nuts to:
80 lbf-ft (108 N·m , 11 kgf·m)

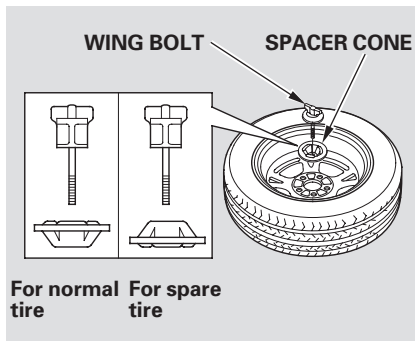

15. Place the flat tire face down in the spare tire well.
16. Remove the spacer cone from the wing bolt, turn it over, and put it back on the bolt.
17. Secure the flat tire by screwing the wing bolt back into its hole.

18. Store the jack in the tool case.

⚠ WARNING

Loose items can fly around the interior in a crash and could seriously injure the occupants.

Store the wheel, jack, and tools securely before driving.

19. Store the center cap in the trunk. Make sure it does not get scratched or damaged.
20. Lower the trunk floor, then close the trunk lid.

Diagnosing why the engine won't start falls into two areas, depending on what you hear when you turn the ignition switch to the START (III) position:

- You hear nothing, or almost nothing. The engine's starter motor does not operate at all, or operates very slowly.
- You can hear the starter motor operating normally, or the starter motor sounds like it is spinning faster than normal, but the engine does not start up and run.

Nothing Happens or the Starter Motor Operates Very Slowly

When you turn the ignition switch to the START (III) position, you do not hear the normal noise of the engine trying to start. You may hear a clicking sound, a series of clicks, or nothing at all.

Check these things:

- Check the transmission interlock. The transmission must be in Park or neutral or the starter will not operate.
- Turn the ignition switch to the ON (II) position. Turn on the headlights, and check their brightness. If the headlights are very dim or do not come on at all, the battery is discharged. See **Jump Starting** on page [223](#) .

- Turn the ignition switch to the START (III) position. If the headlights do not dim, check the condition of the fuses. If the fuses are OK, there is probably something wrong with the electrical circuit for the ignition switch or starter motor. You will need a qualified technician to determine the problem. See **Emergency Towing** on page [237](#) .

If the headlights dim noticeably or go out when you try to start the engine, either the battery is discharged or the connections are corroded. Check the condition of the 12 volt battery and terminal connections (see page [212](#)). You can then try jump starting the vehicle from a booster battery (see page [223](#)).

If the Engine Won't Start

The Starter Operates Normally

In this case, the starter motor's speed sounds normal, or even faster than normal, when you turn the ignition switch to the START (III) position, but the engine does not run.

- Are you using a properly coded key? An improperly coded key will cause the immobilizer system indicator in the instrument panel to blink rapidly (see page [59](#)).
- Are you using the proper starting procedure? Refer to **Starting the Engine** on page [165](#) .

- Do you have fuel? Check the fuel gauge; the low fuel indicator may not be working.
- There may be an electrical problem, such as no power to the fuel pump. Check all the fuses (see page [231](#)).

If you find nothing wrong, you will need a qualified technician to find the problem. See **Emergency Towing** on page [237](#) .

Although this seems like a simple procedure, you should take several precautions.

⚠ WARNING

A battery can explode if you do not follow the correct procedure, seriously injuring anyone nearby.

Keep all sparks, open flames, and smoking materials away from the battery.

You cannot start your vehicle by pushing or pulling it.

To jump start your vehicle:

1. Open the hood, and check the physical condition of the 12 volt battery.

NOTICE

If a battery sits in extreme cold, the electrolyte inside can freeze. Attempting to jump start with a frozen battery can cause it to rupture.

2. Turn off all electrical accessories: heater, A/C, climate control, audio system, lights, etc. Put the transmission in Park, and set the parking brake.

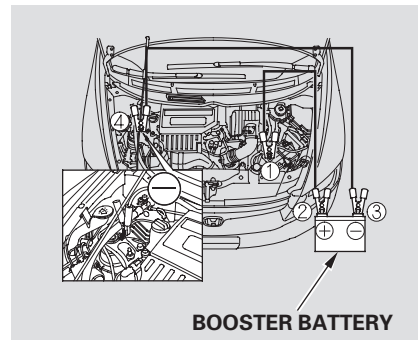

The numbers in the illustration show you the order to connect the jumper cables.

3. Connect one jumper cable to the positive (+) terminal on your battery. Connect the other end to the positive (+) terminal on the booster battery.

CONTINUED

Jump Starting

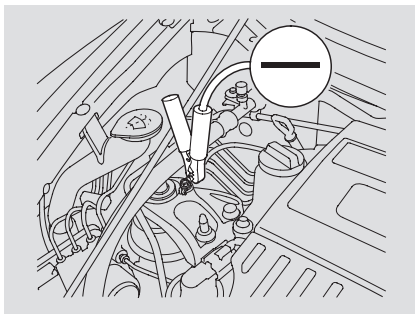

4. Connect the second jumper cable to the negative (–) terminal on the booster battery. Connect the other end to the grounding strap as shown. Do not connect this jumper cable to any other part of the engine.
5. If the booster battery is in another vehicle, have an assistant start that vehicle and run it at a fast idle.

6. Start the vehicle. If the starter motor still operates slowly, check that the jumper cables have good metal-to-metal contact.
7. Once your vehicle is running, disconnect the negative cable from your vehicle, then from the booster battery. Disconnect the positive cable from your vehicle, then from the booster battery.

Keep the ends of the jumper cables away from each other and any metal on the vehicle until everything is disconnected. Otherwise, you may cause an electrical short.

If your vehicle's 12 volt battery is disconnected or goes dead, the IMA battery level gauge reading will not be correct the next time you turn the ignition switch to the ON (II) position. It will show less than the actual level temporarily. It will show the correct level after you drive for at least 30 minutes.

The reading on the vehicle's temperature gauge should stay in the midrange. If it climbs to the red mark, you should determine the reason (hot day, driving up a steep hill, etc.).

When the current fuel mileage is shown on the display, the temperature gauge will interrupt on the display and blink for several times if the coolant temperature rises to 224°F (118°C) or more. At the same time, the beeper sounds once.

If your vehicle overheats, you should take immediate action. The only indication may be the temperature gauge climbing to or above the red mark. Or you may see steam or spray coming from under the hood.

NOTICE

Driving with the temperature gauge reading at the red mark can cause serious damage to your engine.

⚠ WARNING

Steam and spray from an overheated engine can seriously scald you.

Do not open the hood if steam is coming out.

1. Safely pull to the side of the road. Put the transmission in Park, and set the parking brake. Turn off all accessories, and turn on the hazard warning lights.

2. If you see steam and/or spray coming from under the hood, turn off the engine. Wait until you see no more signs of steam or spray, then open the hood.
3. If you do not see steam or spray, leave the engine running, and watch the temperature gauge. If the high heat is due to overloading, the engine should start to cool down almost immediately. If it does, wait until the temperature gauge reading comes down to the midpoint, then continue driving.
4. If the temperature gauge stays at the red mark, turn off the engine.

CONTINUED

If the Engine Overheats

5. Look for any obvious coolant leaks, such as a split radiator hose. Everything is still extremely hot, so use caution. If you find a leak, it must be repaired before you continue driving (see **Emergency Towing** on page [237](#)).
6. If you don't find an obvious leak, check the coolant level in the radiator reserve tank (see page [154](#)). Add coolant if the level is below the MIN mark.
7. If there was no coolant in the reserve tank, you may need to add coolant to the radiator. Let the engine cool down until the reading reaches the middle of the temperature gauge or lower before checking the radiator.

WARNING

Removing the radiator cap while the engine is hot can cause the coolant to spray out, seriously scalding you.

Always let the engine and radiator cool down before removing the radiator cap.

8. Using gloves or a large heavy cloth, turn the radiator cap counterclockwise, without pushing down, to the first stop. After the pressure releases, push down on the cap, and turn it until it comes off.
9. Start the engine, and set the interior temperature to maximum. Add coolant to the radiator up to the base of the filler neck. If you do not have the proper coolant mixture available, you can add plain water. Remember to have the cooling system drained and refilled with the proper mixture as soon as you can.
10. Put the radiator cap back on tightly. Run the engine, and check the temperature gauge. If it goes back to the red mark, the engine needs repair (see **Emergency Towing** on page [237](#)).
11. If the temperature stays normal, check the coolant level in the radiator reserve tank. If it has gone down, add coolant to the MAX mark. Put the cap back on tightly.



This indicator should never come on when the engine is running. If it starts flashing or stays on, the oil pressure has dropped very low or lost pressure. Serious engine damage is possible, and you should take immediate action.

NOTICE

Running the engine with low oil pressure can cause serious mechanical damage almost immediately. Turn off the engine as soon as you can safely get the vehicle stopped.

1. Safely pull off the road, and shut off the engine. Turn on the hazard warning lights.
2. Let the vehicle sit for a minute. Open the hood, and check the oil level (see page 153). An engine very low on oil can lose pressure during cornering and other driving maneuvers.
3. If necessary, add oil to bring the level back to the full mark on the dipstick (see page 189).
4. Start the engine and watch the oil pressure indicator. If it does not go out within 10 seconds, turn off the engine. There is a mechanical problem that needs to be repaired before you can continue driving (see **Emergency Towing** on page 237).

The engine running generates the oil pressure. When the Auto Idle Stop is activated, the engine is stopped, the oil pressure is dropped, and the low oil pressure indicator does not come on.

Charging System Indicator



If the charging system indicator comes on brightly when the engine is running, the 12 volt battery is not being charged.

Immediately turn off all electrical accessories. Try not to use other electrically operated controls such as the power windows. Keep the engine running; starting the engine will discharge the battery rapidly.

Go to a service station or garage where you can get technical assistance.

If the Auto Idle Stop is active for an extended period, the charging system indicator may come on. If it happens, start the engine.

The charging system indicator may also come on if the Integrated Motor Assist (IMA) battery charge drops below a desired level and the engine starts to recharge the battery.

This indicator may blink after you start the vehicle in the morning when the temperature is below -20°F (-30°C). It will stop blinking when the IMA battery warms up.



If the indicator comes on while driving, it means one of the engine's emissions control systems may have a problem. Even though you may feel no difference in your vehicle's performance, it can reduce your fuel economy and cause increased emissions. Continued operation may cause serious damage.

If you have recently refueled your vehicle, the indicator coming on could be due to a loose or missing fuel fill cap. You will also see a "CHECK FUEL CAP" message on the information display. Tighten the cap until it clicks at least once (see page 151). Tightening the cap will not turn the indicator off immediately; it takes at least three days of normal driving.

If the indicator comes on repeatedly, even though it may turn off as you continue driving, have your vehicle checked by your dealer as soon as possible.

NOTICE

If you keep driving with the Malfunction Indicator Lamp on, you can damage your vehicle's emissions controls and engine. Those repairs may not be covered by your vehicle's warranties. This indicator may also come on with the "D" indicator.

Readiness Code

Your vehicle has certain "readiness codes" that are part of the on-board diagnostics for the emissions systems. In some states, part of the emissions testing is to make sure these codes are set. If they are not set, the test cannot be completed.

If the battery in your vehicle has been disconnected or gone dead, these codes are erased. It takes at least three days of driving under various conditions to set the codes again.

To check if they are set, turn the ignition switch to the ON (II) position, without starting the engine. The malfunction indicator lamp will come on for 20 seconds. If it then goes off, the readiness codes are set. If it blinks five times, the readiness codes are not set. If possible, do not take your vehicle for a state emissions test until the readiness codes are set. Refer to **State Emissions Testing** for more information (see page 250).

Brake System Indicator

U.S. **Canada**

BRAKE



The brake system indicator normally comes on when

you turn the ignition switch to the ON (II) position and as a reminder to check the parking brake. It will stay on if you do not fully release the parking brake.

If the brake system indicator comes on while driving, the brake fluid level is probably low. Press lightly on the brake pedal to see if it feels normal. If it does, check the brake fluid level the next time you stop at a service station (see page [196](#)).

If the fluid level is low, take your vehicle to a dealer, and have the brake system inspected for leaks or worn brake pads.

However, if the brake pedal does not feel normal, you should take immediate action. A problem in one part of the system's dual circuit design will still give you braking at two wheels. You will feel the brake pedal go down much farther before the vehicle begins to slow down, and you will have to press harder on the pedal.

Slow down by shifting to a lower gear, and pull to the side of the road when it is safe. Because of the long distance needed to stop, it is hazardous to drive the vehicle. You should have it towed and repaired as soon as possible (see **Emergency Towing** on page [237](#)).

If you must drive the vehicle a short distance in this condition, drive slowly and carefully.

If the ABS indicator comes on with the brake system indicator, have your vehicle inspected by your dealer immediately.

If the regenerate brake system indicator (amber) comes on with the parking brake system indicator (red) with the parking brake released, there may be a malfunction with the power-assist feature. When the power-assist feature malfunctions, the brake indicator (red) comes on and a buzzer sounds for a second. The power-assist feature may stop when the brake effect is weak. Stop your vehicle immediately at a safe place and contact a dealer.

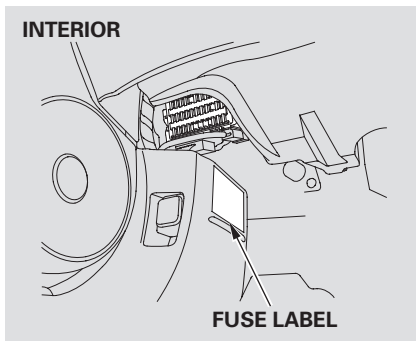

The vehicle's fuses are contained in three fuse boxes.

The interior fuse box is underneath the steering column.

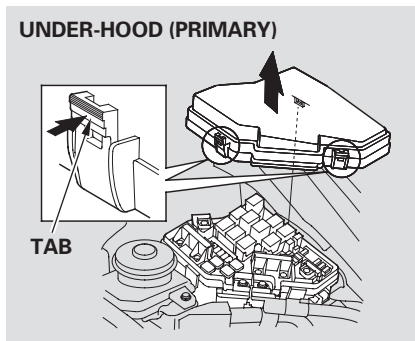

The primary and secondary under-hood fuse boxes are in the engine compartment on the driver's side.

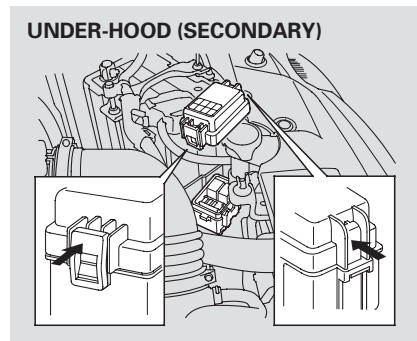

Fuses

Checking and Replacing Fuses

If something electrical in your vehicle stops working, the first thing you should check for is a blown fuse. Determine from the chart on pages [235](#) and [236](#), or the diagram on the fuse box lid, which fuse or fuses control that device. Check those fuses first, but check all the fuses before deciding that a blown fuse is the cause. Replace any blown fuses, and check if the device works.

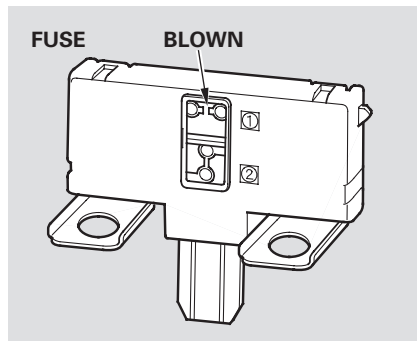

1. Turn the ignition switch to the LOCK (0) position. Make sure the headlights and all other accessories are off.
2. Remove the cover from the fuse box.

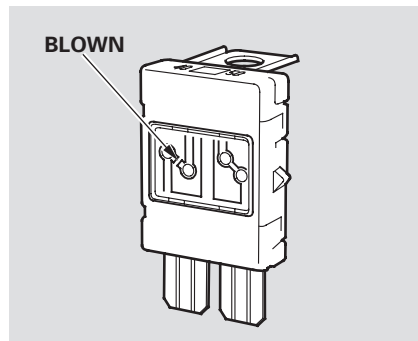

3. Check each of the large fuses in the primary under-hood fuse box by looking through the top at the wire inside. Remove the screws with a Phillips-head screwdriver.

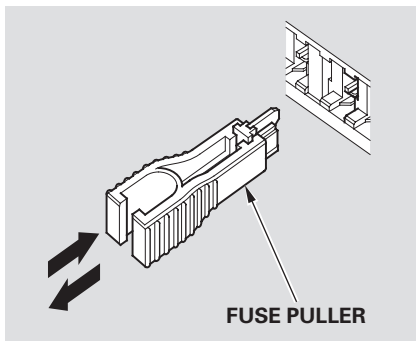

4. Check the smaller fuses in the under-hood fuse boxes and all the fuses in the interior fuse box by pulling out each one with the fuse puller provided in the primary under-hood fuse box.

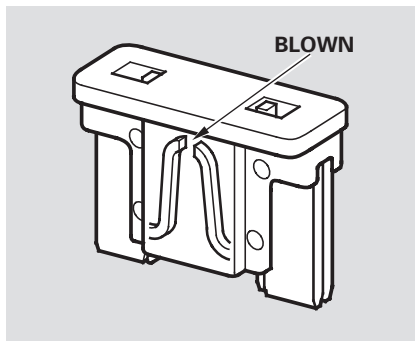

5. Look for a blown wire inside the fuse. If it is blown, replace it with one of the spare fuses of the same rating or lower. The spare fuses are provided back of the under-hood fuse cover.

If you cannot drive the vehicle without fixing the problem, and you do not have a spare fuse, take a fuse of the same rating or a lower rating from one of the other circuits. Make sure you can do without that circuit temporarily (such as the accessory power socket or radio).

If you replace the blown fuse with a spare fuse that has a lower rating, it might blow out again. This does not indicate anything wrong. Replace the fuse with one of the correct rating as soon as you can.

CONTINUED

NOTICE

Replacing a fuse with one that has a higher rating greatly increases the chances of damaging the electrical system. If you do not have a replacement fuse with the proper rating for the circuit, install one with a lower rating.

6. If the replacement fuse of the same rating blows in a short time, there is probably a serious electrical problem with your vehicle. Leave the blown fuse in that circuit, and have your vehicle checked by a qualified technician.

When the audio system is disabled, the clock setting in the audio system will be canceled. You will need to reset the clock according to the instructions in the audio system section in this owner's manual.

UNDER-HOOD PRIMARY FUSE BOX

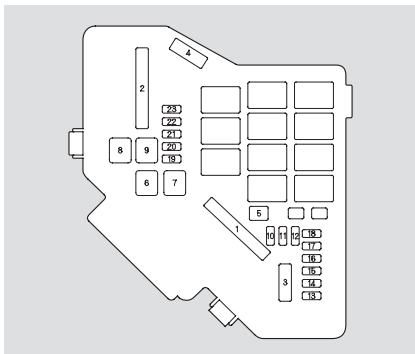

No.	Amps.	Circuits Protected
1	100 A	Main Fuse
	70 A	EPS
2	80 A	Option Main
	50 A	Ignition Switch Main
3	30 A	ABS Motor
	30 A	ABS F/S

No.	Amps.	Circuits Protected
4	50 A	Headlight Main
	40 A	Power Window Main
5	40 A	Booster Motor
6	20 A	Sub Fan Motor
7	20 A	Main Fan Motor
8	30 A	Rear Defogger
9	40 A	Blower
10	10 A	Hazard
11	15 A	FI Sub
12	15 A	Stop and Horn
13	15 A	IG Coil (EX)
14	15 A	IG Coil (IN)
15	7.5 A	Oil Level
16	—	Not Used
17	—	Not Used
18	20 A	IG Coil
19	15 A	FI Main
20	7.5 A	MG Clutch
21	15 A	DBW
22	7.5 A	Interior Light
23	10 A	Back Up

UNDER-HOOD SECONDARY FUSE BOX

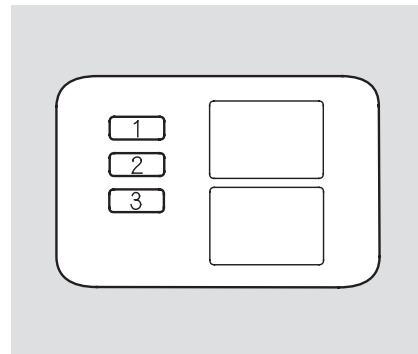

No.	Amps.	Circuits Protected
1	10 A	IMA2
2	7.5 A	IMA1
3	15 A	Booster MS

Fuse Locations

INTERIOR FUSE BOX

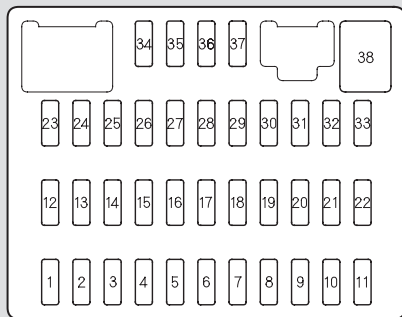

No.	Amps.	Circuits Protected
1	7.5 A	Power Window
2	15 A	Fuel Pump
3	10 A	IG1 ACG
4	7.5 A	ABS Unit
5	—	Not Used
6	—	Not Used
7	—	Not Used
8	—	Not Used

No.	Amps.	Circuits Protected
9	7.5 A	ODS
10	7.5 A	METER
11	10 A	SRS
12	10 A	Right Headlight High Beam
13	10 A	Left Headlight High Beam
14	7.5 A	Small (Interior)
15	7.5 A	Small (Exterior)
16	10 A	Right Headlight Low Beam

No.	Amps.	Circuits Protected
17	10 A	Left Headlight Low Beam
18	20 A	Headlight High Main
19	15 A	Small (Main)
20	—	Not Used
21	20 A	Headlight Low Main
22	(7.5 A)	(HAC)
23	(7.5 A)	STS
24	—	Not Used
25	20 A	Door Lock
26	20 A	Driver's Power Window
27	—	Not Used
28	(15 A)	Rear ACC Socket
29	15 A	ACC
30	20 A	Passenger's Power Window
31	—	Not Used
32	20 A	Right Rear Power Window
33	20 A	Left Rear Power Window
34	—	Not Used
35	7.5 A	ACC Radio
36	10 A	HAC
37	7.5 A	Daytime Running Light
38	30 A	Wiper

If your vehicle needs to be towed, call a professional towing service or organization. Never tow your vehicle with just a rope or chain. It is very dangerous.

There are two ways to tow your vehicle:

Flat-bed Equipment — The operator loads your vehicle on the back of a truck. **This is the best way to transport your vehicle.**

Wheel-lift Equipment — The tow truck uses two pivoting arms that go under the tires (front) and lift them off the ground. The other two tires remain on the ground. **This is an acceptable way to tow your vehicle.**

If, due to damage, your vehicle must be towed with the front wheels on the ground, do this:

- Release the parking brake.
- Start the engine.
- Shift to D, then to N.
- Turn off the engine.
- Leave the ignition switch in the ACCESSORY (I) position so the steering wheel does not lock.

NOTICE

Improper towing preparation will damage the transmission. Follow the above procedure exactly. If you cannot shift the transmission or start the engine, your vehicle must be transported with the front wheels off the ground.

With the front wheels on the ground, it is best to tow the vehicle no farther than 50 miles (80 km), and keep the speed below 35 mph (55 km/h).

CONTINUED

Emergency Towing

NOTICE

Trying to lift or tow your vehicle by the bumpers will cause serious damage. The bumpers are not designed to support the vehicle's weight.

NOTICE

The steering system can be damaged if the steering wheel is locked. Leave the ignition switch in the ACCESSORY (I) position, and make sure the steering wheel turns freely before you begin towing.

The diagrams in this section give you the dimensions and capacities of your vehicle and the locations of the identification numbers. It also includes information you should know about your vehicle's tires and emissions control systems.

Identification Numbers.....	240	Emissions Controls.....	247
Specifications	242	The Clean Air Act.....	247
DOT Tire Quality Grading		Crankcase Emissions Control	
(U.S. Vehicles)	244	System.....	247
Uniform Tire Quality		Evaporative Emissions Control	
Grading	244	System.....	247
Treadwear	244	Onboard Refueling Vapor	
Traction.....	244	Recovery	247
Temperature	245	Exhaust Emissions Controls...	248
Tire Labeling.....	246	PGM-FI System	248
		Ignition Timing Control	
		System.....	248
		Exhaust Gas Recirculation	
		(EGR) System.....	248
		Three Way Catalytic	
		Converter.....	248
		Replacement Parts.....	248
		Three Way Catalytic Converter...	249
		State Emissions Testing	250

Identification Numbers

Your vehicle has several identifying numbers in various places.

The vehicle identification number (VIN) is the 17-digit number your dealer uses to register your vehicle for warranty purposes. It is also necessary for licensing and insuring your vehicle. The easiest place to find the VIN is on a plate fastened to the top of the dashboard. You can see it by looking through the windshield on the driver's side. It is also on the certification label attached to the driver's doorjamb, and is stamped on the engine compartment bulkhead. The VIN is also provided in bar code on the certification label.

The VIN is also located on the engine bulkhead. Slide the cover on the engine compartment bulkhead to view the VIN. Always close the cover when finished.

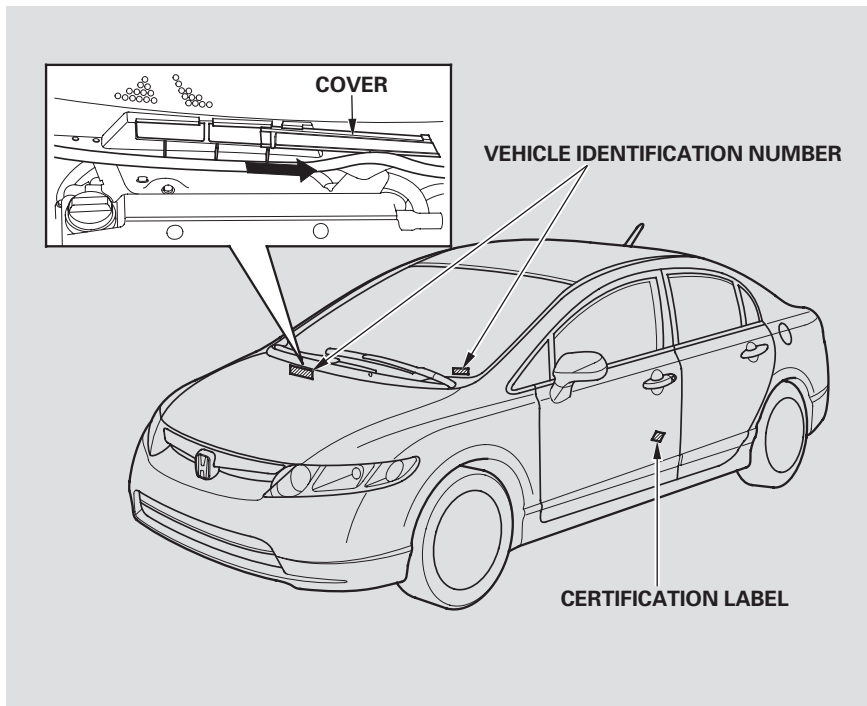

The engine number is stamped into the engine block.

The transmission number is on a label on top of the transmission.

The IMA Motor Number is stamped on the motor housing.

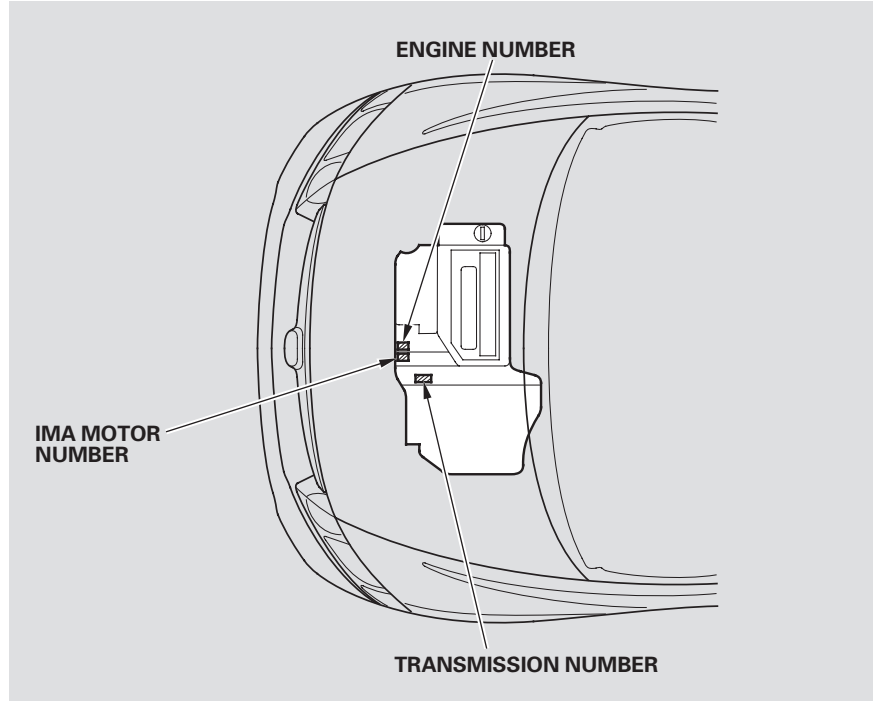

Specifications

Dimensions

Length		176.7 in (4,489 mm)
Width		69.0 in (1,752 mm)
Height		56.3 in (1,430 mm)
Wheelbase		106.3 in (2,700 mm)
Track	Front	59.1 in (1,501 mm)
	Rear	60.2 in (1,529 mm)

Weights

Gross vehicle weight rating	See the certification label attached to the driver's doorjamb.
-----------------------------	--

Engine

Type	Water cooled 4-stroke SOHC i-VTEC gasoline engine with Hybrid Electric
Bore x Stroke	2.87 x 3.15 in (73.0 x 80.0 mm)
Displacement	82 cu-in (1.339 cm ³)
Compression ratio	10.8
Spark plugs	ILFR6J-11K (NGK) SK20HPR-L11 (DENSO)

Capacities

Fuel tank		Approx. 13.2 US gal (50 ℓ)
Engine coolant	Change* ¹	1.255 US gal (4.75 ℓ)
	Total	1.59 US gal (6.0 ℓ)
Engine oil	Change* ²	
	Including filter	3.4 US qt (3.2 ℓ)
	Without filter	3.2 US qt (3.0 ℓ)
	Total	4.0 US qt (3.8 ℓ)
Automatic transmission fluid	Change	3.0 US qt (2.8 ℓ)
	Total	5.4 US qt (5.1 ℓ)
Windshield washer reservoir	U.S. Vehicles	2.6 US qt (2.5 ℓ)
	Canada Vehicles	4.8 US qt (4.5 ℓ)

* 1 : Including the coolant in the reserve tank and that remaining in the engine

Reserve tank capacity: 0.108 US gal (0.41 ℓ)

* 2 : Excluding the oil remaining in the engine

Air Conditioning

Refrigerant type	HFC-134a (R-134a)
Charge quantity	16–18 oz (450–500 g)
Lubricant oil type	SE-10Y

Lights

Headlights	High	12 V – 60 W (HB3)
	Low	12 V – 51 W (HB4)
Front turn signal/side marker lights		12 V – 12.8/14 W – 24/2.2 CP
Rear turn signal lights		12 V – 21 W
Brake/Taillights		12 V – 21/5 W
Back-up lights		12 V – 21 W
Rear side marker lights		12 V – 2 CP
Taillights		12 V – 3 CP
License plate lights		12 V – 5 W
Ceiling light		12 V – 8 W
Spotlights		12 V – 8 W
Trunk light		12 V – 5 W

12 Volt Battery

Capacity	12 V – 35 AH/20 HR
	12 V – 28 AH/5 HR

Fuses

Interior	See page 231 or the fuse label attached to the inside of the fuse box door under the steering column.
Under-hood	See page 231 or the fuse box cover.

Alignment

Toe-in	Front	0.00 in (0.0 mm)
	Rear	2.0 in (2.0 mm)
Camber	Front	–0°3'
	Rear	–1°39'
Caster	Front	7°6'

Tires

Size	Front/Rear	P195/65R15 89S
	Spare	T125/70D15 95M
Pressure	Front/Rear	32 psi (220 kPa , 2.2 kgf/cm ²)
	Spare	60 psi (420 kPa , 4.2 kgf/cm ²)

DOT Tire Quality Grading (U.S. Vehicles)

The tires on your vehicle meet all U.S. Federal Safety Requirements. All tires are also graded for treadwear, traction, and temperature performance according to Department of Transportation (DOT) standards. The following explains these gradings.

Uniform Tire Quality Grading

Quality grades can be found where applicable on the tire sidewall between the tread shoulder and the maximum section width. For example:

Treadwear 200

Traction AA

Temperature A

All passenger car tires must conform to Federal Safety Requirements in addition to these grades.

Treadwear

The treadwear grade is a comparative rating based on the wear rate of the tire when tested under controlled conditions on a specified government test course. For example, a tire graded 150 would wear one and one-half (1 1/2) times as well on the government course as a tire graded 100. The relative performance of tires depends upon the actual conditions of their use, however, and may depart significantly from the norm due to variations in driving habits, service practices, and differences in road characteristics and climate.

Traction – AA, A, B, C

The traction grades, from highest to lowest, are AA, A, B, and C. Those grades represent the tire's ability to stop on wet pavement as measured under controlled conditions on specified government test surfaces of asphalt and concrete. A tire marked C may have poor traction performance.

Warning: The traction grade assigned to this tire is based on straight-ahead braking traction tests, and does not include acceleration, cornering, hydroplaning, or peak traction characteristics.

Temperature – A, B, C

The temperature grades are A (the highest), B, and C, representing the tire's resistance to the generation of heat and its ability to dissipate heat when tested under controlled conditions on a specified indoor laboratory test wheel. Sustained high temperature can cause the material of the tire to degenerate and reduce tire life, and excessive temperature can lead to sudden tire failure. The grade C corresponds to a level of performance which all passenger car tires must meet under the Federal Motor Vehicle Safety Standard No. 109. Grades B and A represent higher levels of performance on the laboratory test wheel than the minimum required by law.

Warning: The temperature grade for this tire is established for a tire that is properly inflated and not overloaded. Excessive speed, underinflation, or excessive loading, either separately or in combination, can cause heat buildup and possible tire failure.

Tire Labeling

The tires that came on your vehicle have a number of markings. Those you should be aware of are described below.

Tire Size

Whenever tires are replaced, they should be replaced with tires of the same size. The following is an example of tire size with an explanation of what each component means.

P195/65 R15 89S

P — Vehicle type (P indicates passenger vehicle).

195 — Tire width in millimeters.

65 — Aspect ratio (the tire's section height as a percentage of its width).

R — Tire construction code (R indicates radial).

15 — Rim diameter in inches.

89 — Load index (a numerical code associated with the maximum load the tire can carry).

S — Speed symbol (an alphabetical code indicating the maximum speed rating).

Tire Identification Number

The tire identification number (TIN) is a group of numbers and letters that look like the following example TIN. TIN is located on the sidewall of the tire.

DOT B97R FW6X 2202

DOT — This indicates that the tire meets all requirements of the U.S. Department of Transportation.

B97R — Manufacturer's identification mark.

FW6X — Tire type code.

2202 — Date of manufacture.

Maximum Tire Pressure

Max Press — The maximum air pressure the tire can hold.

Maximum Tire Load

Max Load — The maximum load the tire can carry at maximum air pressure.

The burning of gasoline in your vehicle's engine produces several by-products. Some of these are carbon monoxide (CO), oxides of nitrogen (NO_x), and hydrocarbons (HC). Gasoline evaporating from the tank also produces hydrocarbons. Controlling the production of NO_x, CO, and HC is important to the environment. Under certain conditions of sunlight and climate, NO_x and HC react to form photochemical "smog." Carbon monoxide does not contribute to smog creation, but it is a poisonous gas.

The Clean Air Act

The United States Clean Air Act* sets standards for automobile emissions. It also requires that automobile manufacturers explain to owners how their emissions controls work and what to do to maintain them. This section summarizes how the emissions controls work.

* In Canada, Honda vehicles comply with the Canadian emission requirements, as specified in an agreement with Environment Canada, at the time they are manufactured.

Crankcase Emissions Control System

Your vehicle has a positive crankcase ventilation system. This keeps gasses that build up in the engine's crankcase from going into the atmosphere. The positive crankcase ventilation valve routes them from the crankcase back to the

intake manifold. They are then drawn into the engine and burned.

Evaporative Emissions Control System

As gasoline evaporates in the fuel tank, an evaporative emissions control canister filled with charcoal adsorbs the vapor. It is stored in this canister while the engine is off. After the engine is started and warmed up, the vapor is drawn into the engine and burned during driving.

Onboard Refueling Vapor Recovery

The onboard refueling vapor recovery (ORVR) system captures the fuel vapors during refueling. The vapors are adsorbed in a canister filled with activated carbon. While driving, the fuel vapors are drawn into the engine and burned off.

Emissions Controls

Exhaust Emissions Controls

The exhaust emissions controls include four systems: PGM-FI, ignition timing control, exhaust gas recirculation, and three way catalytic converter. These four systems work together to control the engine's combustion and minimize the amount of HC, CO, and NOx that come out the tailpipe. The exhaust emissions control systems are separate from the crankcase and evaporative emissions control systems.

PGM-FI System

The PGM-FI system uses sequential multiport fuel injection. It has three subsystems: air intake, engine control, and fuel control. The powertrain control module (PCM) uses various sensors to determine how much air is going into the engine. It then controls how much fuel to inject under all operating conditions.

Ignition Timing Control System

This system constantly adjusts the ignition timing, reducing the amount of HC, CO, and NOx produced.

Exhaust Gas Recirculation (EGR) System

The exhaust gas recirculation (EGR) system takes some of the exhaust gas and routes it back into the intake manifold. Adding exhaust gas to the air/fuel mixture reduces the amount of NOx produced when the fuel is burned.

Three Way Catalytic Converter

The three way catalytic converter is in the exhaust system. Through chemical reactions, it converts HC, CO, and NOx in the engine's exhaust to carbon dioxide (CO₂), nitrogen (N₂), and water vapor.

Replacement Parts

The emissions control systems are designed and certified to work together in reducing emissions to levels that comply with the Clean Air Act. To make sure the emissions remain low, you should use only new Honda replacement parts or their equivalent for repairs. Using lower quality parts may increase the emissions from your vehicle.

The emissions control systems are covered by warranties separate from the rest of your vehicle. Read your warranty manual for more information.

The three way catalytic converter contains precious metals that serve as catalysts, promoting chemical reactions to convert the exhaust gasses without affecting the metals. The catalytic converter is referred to as a three-way catalyst, since it acts on HC, CO, and NOx. A replacement unit must be an original Honda part or its equivalent.

The three way catalytic converter must operate at a high temperature for the chemical reactions to take place. It can set on fire any combustible materials that come near it. Park your vehicle away from high grass, dry leaves, or other flammables.

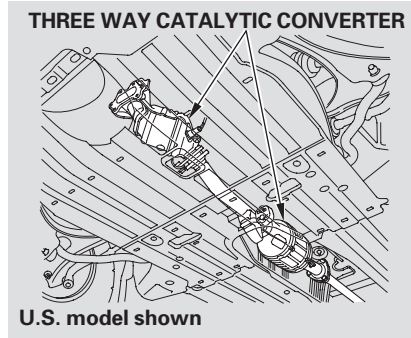

A defective three way catalytic converter contributes to air pollution, and can impair your engine's performance. Follow these guidelines to protect your vehicle's three way catalytic converter.

- Always use unleaded gasoline. Even a small amount of leaded gasoline can contaminate the catalyst metals, making the three way catalytic converter ineffective.
- Keep the engine well maintained.
- Have your vehicle diagnosed and repaired if it is misfiring, back-firing, stalling, or otherwise not running properly.

State Emissions Testing

Testing of Readiness Codes

If you take your vehicle for a state emissions test shortly after the battery has been disconnected or gone dead, it may not pass the test. This is because of certain “readiness codes” that must be set in the on-board diagnostics for the emissions systems. These codes are erased when the battery is disconnected, and set again only after several days of driving under a variety of conditions.

If the testing facility determines that the readiness codes are not set, you will be requested to return at a later date to complete the test. If you must get the vehicle retested within the next two or three days, you can condition the vehicle for retesting by doing the following.

- Make sure the gas tank is nearly, but not completely, full (around 3/4).

- Make sure the vehicle has been parked with the engine off for 6 hours or more.
- Make sure the ambient temperature is between 40° and 95° F.
- Without touching the accelerator pedal, start the engine, and let it idle for 20 seconds.
- Keep the vehicle in Park. Increase the engine speed to 2,000 rpm, and hold it there until the temperature gauge rises to at least 1/4 of the scale (about 3 minutes).
- Select a nearby lightly traveled major highway where you can maintain a speed of 50 to 60 mph for at least 20 minutes. Drive on the highway in D. Do not use the cruise control. When traffic allows, drive for 90 seconds without moving the accelerator pedal.

(Vehicle speed may vary slightly; this is okay.) If you cannot do this for a continuous 90 seconds because of traffic conditions, drive for at least 30 seconds, then repeat it two more times (for a total of 90 seconds).

- Then drive in city/suburban traffic for at least 10 minutes. When traffic conditions allow, let the vehicle coast for several seconds without using the accelerator pedal or the brake pedal.
- Stop the vehicle, turn off the ignition switch, and leave it off for 30 minutes.

If the testing facility determines the readiness codes are still not set, see your dealer.

Customer Service Information.....	252
Warranty Coverages	253
Reporting Safety Defects (U.S. Vehicles)	254
Authorized Manuals.....	255

Customer Service Information

Honda dealership personnel are trained professionals. They should be able to answer all your questions. If you encounter a problem that your dealership does not solve to your satisfaction, please discuss it with the dealership's management. The service manager or general manager can help. Almost all problems are solved in this way.

If you are dissatisfied with the decision made by the dealership's management, contact your Honda Customer Service Office.

U.S. Owners:

American Honda Motor Co., Inc.
Honda Automobile Customer Service
Mail Stop 500-2N-7A
1919 Torrance Boulevard
Torrance, California 90501-2746

Tel: (800) 999-1009

Canadian Owners: **CUSTOMER RELATIONS RELATIONS AVEC LA CLIENTÈLE**

Honda Canada Inc.
715 Milner Avenue
Toronto, ON
M1B 2K8

Tel: 1-888-9-HONDA-9
Fax: Toll-free 1-877-939-0909
Toronto (416) 287-4776

In Puerto Rico and the U.S. Virgin Islands:

Bella International
P.O. Box 190816
San Juan, PR 00919-0816

Tel: (787) 620-7546

When you call or write, please give us this information:

- Vehicle Identification Number (see page [240](#))
- Name and address of the dealer who services your vehicle
- Date of purchase
- Mileage on your vehicle
- Your name, address, and telephone number
- A detailed description of the problem
- Name of the dealer who sold the vehicle to you

U.S. Owners

Your new vehicle is covered by these warranties:

New Vehicle Limited Warranty — covers your new vehicle, except for the battery, emissions control systems, and accessories, against defects in materials and workmanship.

Emissions Control Systems Defects Warranty and Emissions Performance Warranty — these two warranties cover your vehicle's emissions control systems. Time, mileage, and coverage are conditional. Please read your warranty booklet for exact information.

Original Equipment Battery Limited Warranty — this warranty gives up to 100 % credit toward a replacement battery.

Seat Belt Limited Warranty — a seat belt that fails to function properly is covered by a limited warranty. Please read your warranty booklet for details.

Rust Perforation Limited Warranty — all exterior body panels are covered for rust-through from the inside for the specified time period with no mileage limit.

Accessory Limited Warranty — Honda accessories are covered under this warranty. Time and mileage limits depend on the type of accessory and other factors. Please read your warranty booklet for details.

Replacement Parts Limited Warranty — covers all Honda replacement parts against defects in materials and workmanship.

Replacement Battery Limited Warranty — provides prorated coverage for a replacement battery purchased from your dealer.

Replacement Muffler Lifetime Limited Warranty — provides coverage for as long as the purchaser of the muffler owns the vehicle.

Restrictions and exclusions apply to all these warranties. Please read the 2007 Honda warranty information booklet that came with your vehicle for precise information on warranty coverages. Your vehicle's original tires are covered by their manufacturer. Tire warranty information is in a separate booklet.

Canadian Owners

Please refer to the 2007 warranty manual that came with your vehicle.

Reporting Safety Defects (U.S. Vehicles)

If you believe that your vehicle has a defect which could cause a crash or could cause injury or death, you should immediately inform the National Highway Traffic Safety Administration (NHTSA) in addition to notifying American Honda Motor Co., Inc.

If NHTSA receives similar complaints, it may open an investigation, and if it finds that a safety defect exists in a group of vehicles, it may order a recall and remedy campaign. However, NHTSA cannot become involved in individual problems between you, your dealer, or American Honda Motor Co., Inc.

To contact NHTSA, you may call the Vehicle Safety Hotline toll-free at 1-888-327-4236 (TTY: 1-800-424-9153); go to <http://www.safercar.gov>; or write to: Administrator, NHTSA, 400 Seventh Street, SW., Washington, DC 20590. You can also obtain other information about motor vehicle safety from <http://www.safercar.gov>.

Purchasing Factory Authorized Manuals (U.S. only)

The publications shown below can be purchased from Helm Incorporated. You can order in any of three ways:

- Detach and mail the order form on the right half of this page
- Call Helm Inc. at 1-800-782-4356 (credit card orders only)
- Go online at www.helminc.com

If you are interested in other years or models, contact Helm Inc. at 1-800-782-4356.

Publication Form Number	Form Description	Price Each*
61SNC01	2006-2007 Honda Civic Hybrid Service Manual	\$75.00
61SNC01EL	2006-2007 Honda Civic Hybrid Electrical Troubleshooting Manual	\$50.00
61SNA30	2006 Model Series Honda Civic 2/4 Door Body Repair Manual	\$44.00
31SNC610	2007 Honda Civic Hybrid Owner's Manual	\$35.00
31SNC800	2007 Honda Civic Hybrid Navigation System Owner's Manual	\$29.00
31SNCM10	2007 Honda Civic Hybrid Honda Service History	\$12.00
31SNCQ10	2007 Honda Civic Hybrid Quick Start Guide	\$12.00
HON-R	Order Form for Previous Years- Indicate Year and Model Desired	FREE

* Prices are subject to change without notice and without incurring obligation.

Valid only for sales within the United States. Canadian owners should contact their authorized Honda dealer.

ORDER TOLL FREE: 1-800-782-4356

(NOTE: For Credit Card Holder Orders Only)

Monday-Friday 8:00 A.M. — 6:00 P.M. EST

MINIMUM CREDIT CARD PURCHASE \$10.00

OR

By completing this form you can order the materials desired. You can pay by check or money order, or charge to your credit card. Mail to Helm Incorporated at the address shown on the back of the order form.

2007 HON	PUBLICATION NUMBER	VEHICLE MODEL		Qty	Price Each*	Total Price
		Name	Year			
* Prices are subject to change without notice and without incurring obligation. Orders are mailed within 10 days. Please allow adequate time for delivery.					TOTAL MATERIAL	
					Mich. Purchases Add 6% Sales Tax	
					HANDLING CHARGE	\$6.95
					GRAND TOTAL	

A

Accessories.....	156
ACCESSORY (Ignition Key Position).....	79
Accessory Power Socket	96
Additives, Engine Oil.....	190
Airbag (SRS)	9, 21
Airbags, Additional Information	21
Additional Safety Precautions....	32
Advanced Airbag System	26
Airbag Service.....	32
How the Passenger Airbag Off Indicator Works.....	31
How the Side Airbag Off Indicator Works.....	30
How the SRS Indicator Works... ..	30
How Your Front Airbags Work.....	24
How Your Side Airbags Work....	28
How Your Side Curtain Airbags Work.....	29
SRS Components	21
Air Conditioning System.....	100
Air Pressure, Tires	208
Antifreeze	192

Anti-lock Brakes (ABS) Indicator.....	59, 174
Operation	174
Anti-theft, Audio System.....	142
Anti-theft Steering Column Lock.....	79
Armrest.....	91
Audio System	106
Auto Door Locking/Unlocking.....	81
Auto Door Locking.....	81
Auto Door Unlocking	83
Auto Idle Stop.....	170, 171
Automatic Seat Belt Tensioners	19
Automatic Speed Control.....	145
Automatic Transmission (CVT) ..	166
Capacity, Fluid	242
Checking Fluid Level.....	195
Shifting.....	167
Shift Lever Position Indicators.....	166
Shift Lever Positions	167
Shift Lock Release.....	169

B

Battery Charging System Indicator.....	62, 228
Jump Starting	223
Maintenance.....	212
Specifications	243
Before Driving	149
Belts, Seat.....	8, 18
Beverage Holder.....	96
Brakes Anti-lock System (ABS)	174
Break-in, New Linings	150
Bulb Replacement	200
Fluid	196
Pad Wear Indicator.....	174
Parking.....	94
System Indicator.....	58, 63, 230
Braking System.....	173
Break-in, New Vehicle	150
Brightness Control, Instruments... ..	74
Brights, Headlights	73

CONTINUED

Index

Bulb Replacement	
Back-up Lights	201
Brake Lights	200, 201
Front Side Marker Lights.....	199
Front Turn Signal Light.....	199
Headlights	197
Parking Lights	199
Rear Side Marker Lights.....	200
Rear Turn Signal Lights	200
Specifications	243
Bulbs, Halogen.....	197

C

Card, PC.....	129
Capacities Chart.....	242
Carbon Monoxide Hazard	52
Carrying Cargo	158
CAUTION, Explanation of	iii
CD Player.....	112
Ceiling Light.....	97
Certification Label.....	240
Chains	211
Changing a Flat Tire	217
Changing Oil	
How to.....	190

When to.....	179
Charging System Indicator	62, 228
Check Fuel Cap Indicator.....	68
Checklist, Before Driving.....	164
Child Safety	34
Child Seats	
LATCH Anchor System.....	43
Lower Anchor	43
Tether Anchor	47
Childproof Door Locks	81
Cleaning the Wheels	207
Clock, Setting the	119
CO in the Exhaust	247
Cold Weather, Starting in.....	165
Compact Spare	216
Controls, Instruments and.....	55
Coolant	
Adding.....	192
Checking.....	154
Proper Solution	192
Temperature Gauge.....	65
Crankcase Emissions Control	
System.....	247
Cruise Control Operation	145
Customer Service Information....	252

D

DANGER, Explanation of.....	iii
Dashboard	3, 56
Daytime Running Lights.....	74
Defects, Reporting Safety.....	254
Defog and Defrost.....	104
Defogger, Rear Window	75
Defrosting the Windows.....	104
Dimensions.....	242
Dimming the Headlights	73
Dipstick	
Automatic Transmission.....	195
Engine Oil.....	153
Directional Signals.....	73
Disc Brake Pad Wear	
Indicators.....	174
Disc Player.....	112
Display Change Button	64
Disposal of Used Oil.....	192
Doors	
Auto Door Locking/Unlocking..	81
Auto Door Locking.....	81
Auto Door Unlocking	83
Locking and Unlocking.....	80
Power Door Locks.....	80

DOT Tire Quality Grading	244
Driver and Passenger Safety	5
Driving	163
Economy	154
Dust and Pollen Filter	204

E

Economy, Fuel	154
Emergencies on the Road	215
Battery, Jump Starting	223
Brake System Indicator	230
Changing a Flat Tire	217
Charging System Indicator	228
Checking the Fuses	231
Low Oil Pressure Indicator	227
Malfunction Indicator Lamp	229
Overheated Engine	225
Emergency Brake	94
Emergency Flashers	74
Emergency Towing	237
Emergency Trunk Opener	86
Emissions Controls	247
Emissions Testing, State	250
Engine	
Coolant Temperature Gauge	65

Engine Speed Limiter	168
Malfunction Indicator	
Lamp	62, 229
Oil Pressure Indicator	62, 227
Oil, What Kind to Use	189
Overheating	225
Specifications	242
Starting	165
Evaporative Emissions Controls ..	247
Exhaust Fumes	52
Expectant Mothers, Use of Seat	
Belts by	16

F

Fan, Interior	101
Features	99
Filling the Fuel Tank	151
Filters	
Dust and Pollen	204
Oil	190
Flashers, Hazard Warning	74
Flat Tire, Changing a	217
Fluids	
Automatic Transmission	195
Brake	196

Windshield Washer	194
FM Stereo Radio	
Reception	139
Four-way Flashers	74
Front Airbags	9, 21
Fuel	150
Fill Door and Cap	151
Gauge	66
Octane Requirement	150
Oxygenated	150
Reserve Indicator	61
Tank, Filling the	151
Fuses, Checking the	231

G

Gas Mileage, Improving	154
Gasohol	150
Gasoline	150
Fuel Reserve Indicator	61
Gauge	66
Octane Requirement	150
Tank, Filling the	151
Gas Station Procedures	151

CONTINUED

Index

Gauges

- Engine Coolant Temperature 65
- Fuel..... 66
- Gearshift Lever Positions
 - Automatic Transmission..... 166
- Glove Box 96

H

- Halogen Headlight Bulbs..... 197
- Hazard Warning Flashers..... 74
- Headlights
 - Aiming..... 197
 - Daytime Running Lights..... 74
 - High Beam Indicator 60
 - Reminder Beeper..... 73
 - Replacing Halogen Bulbs 197
 - Turning on 73
- Head Restraints 91
- Heated Mirrors 94
- High Altitude, Starting at..... 165
- High-Low Beam Switch 73
- Hood, Opening the 152
- Horn..... 71

I

- Identification Number, Vehicle.... 240
- Ignition
 - Keys..... 76
 - Switch..... 79
 - Timing Control System..... 248
- Important Safety Precautions 6
- Indicators, Instrument Panel..... 57
- Infant Restraint 39
- Infant Seats
 - LATCH Anchorage System 43
 - Lower Anchors 43
 - Tether Anchors..... 47
- Inflation, Recommended Tire 208
 - Pressures 208
- Information Display..... 64
- Inside Mirror 93
- Inspection, Tire 209
- Instrument Panel 57
- Instrument Panel Lights 58
- Instrument Panel Brightness 74
- Interior Lights 97
- Introduction..... i

J

- Jacking up the Vehicle 217
- Jack, Tire 217
- Jump Starting 223

K

- Keys..... 76

L

- Label, Certification 240
- Lane Change, Signaling 73
- Lap/Shoulder Belts 14, 18
- LATCH Anchorage System..... 43
- Lights
 - Bulb Replacement 197
 - Indicator..... 60
 - Parking..... 73
 - Turn Signal 73
- Load Limits..... 159
- LOCK (Ignition Key Position) 79

Locks

Anti-theft Steering Column	79
Fuel Fill Door	151
Power Door	80
Trunk	86
Low Coolant Level.....	154
Low Fuel Indicator	61
Lower Anchors.....	43
Low Oil Pressure Indicator	62, 227
Lubricant Specifications Chart	242

M

Maintenance.....	177
Minder.....	179
Minder Indicator.....	61
Owner's Maintenance	
Checks	184
Record.....	186-187
Safety.....	178
Malfunction Indicator Lamp ..	62, 229
Meters, Gauges.....	57, 64
Methanol in Gasoline	150
Mirrors, Adjusting	93
MP3/WMA.....	112

N

Neutral Gear Position.....	168
New Vehicle Break-in	150
NOTICE, Explanation of.....	i
Numbers, Identification.....	240

O

Octane Requirement, Gasoline	150
Odometer.....	64
Odometer, Trip	64
Oil	
Change, How to	190
Change, When to	179
Checking Engine	152
Pressure Indicator	62, 227
Selecting Proper Viscosity.....	189
ON (Ignition Key Position)	79
Onboard Refueling Vapor	
Recovery	247
Outside Mirrors	93
Outside Temperature Indicator	67
Overheating, Engine	225
Owner's Maintenance Checks	184
Oxygenated Fuels.....	150

P

Panel Brightness Control	74
Park Gear Position.....	167
Parking.....	172
Parking Brake	94
Parking Brake and Brake	
System Indicator.....	58, 230
Parking Lights.....	73
Parking Over Things that Burn...	172
PGM-FI System.....	248
Playing the Radio	108
Playing a Disc.....	112
Playing a PC Card.....	129
Pregnancy, Using Seat Belts	16
Protecting Adults and Teens.....	11
Additional Safety Precautions....	17
Advice for Pregnant Women.....	16
Protecting Children	34
General Guidelines.....	34
Protecting Infants.....	39
Protecting Small Children	40
Selecting a Child Seat.....	41
Installing a Child Seat	42

CONTINUED

Index

Protecting Larger Children 48

R

Radiator Overheating..... 225

Radio/CD/Sound System..... 106

Radio/CD/PC Card Sound

System..... 121

Readiness Codes..... 229, 250

Rear Lights, Bulb

Replacement..... 200, 201

Rear View Mirror..... 93

Rear Window Defogger 75

Reclining the Seat-backs..... 90

Remote Transmitter..... 87

Replacement Information

Dust and Pollen Filter 204

Engine Oil and Filter 190

Fuses 232

Light Bulbs 197

Maintenance Minder 179

Tires 207

Wiper Blades..... 204

Replacing Seat Belts After a

Crash 20

Reserve Tank, Engine

Coolant..... 153, 192

Restraint, Child 34

Reverse Gear Position..... 168

Rotation, Tire 210

S

Safety Belts..... 8, 18

Safety Defects, Reporting..... 254

Safety Features 7

Airbags 9

Seat Belts 8

Safety Labels, Location of 53

Safety Messages iii

Seat Belts 8, 18

Additional Information..... 18

Automatic Seat Belt

Tensioners..... 19

Lap/Shoulder Belt..... 14, 18

Maintenance..... 20, 203

Reminder Light and

Beeper..... 18, 58

System Components..... 18

Use During Pregnancy..... 16

Wearing a Lap/Shoulder

Belt 14, 18

Seats, Adjusting the..... 89

Security System 144

Serial Number 240

Service Intervals 185

Service Manual 255

Service Station Procedures 151

Setting the Clock 119

Shift Lever Position Indicators 166

Shift Lock Release..... 169

Side Airbags 9, 28

Off Indicator..... 30, 59

Side Curtain Airbags 29

Side Marker Lights, Bulb

Replacement..... 199

Signaling Turns..... 73

Snow Tires..... 211

Sound System..... 106

Spare Tire

Inflating..... 216

Specifications 243

Specifications Charts..... 242

Speed Control..... 145

Speed-Sensitive Volume

Compensation (SVC) 111, 124

- Spotlights 97
- SRS, Additional Information..... 21
- Additional Safety Precautions.... 32
 - Airbag Service..... 32
 - How the Passenger Airbag Off Indicator Works..... 31
 - How the Side Airbag Off Indicator Works..... 30
 - How the SRS Indicator Works... 30
 - How Your Front Airbags Work..... 24
 - How Your Side Airbags Work... 28
 - How Your Side Curtain Airbags Work..... 29
 - SRS Components 21
- SRS Indicator..... 30, 59
- START (Ignition Key Position) 79
- State Emissions Testing 250
- Starting the Engine..... 165
- In Cold Weather at High Altitude 165
 - With a Dead Battery 223
- Steam Coming from Engine 225
- Steering Wheel
- Adjustment 75
 - Anti-theft Column Lock 79
- Stereo Sound System 106
- Storing Your Vehicle 213
- Supplemental Restraint System..... 9, 21
- Servicing 32
 - SRS Indicator..... 30, 59
 - System Components..... 21
- SVC..... 111, 124
- Synthetic Oil..... 190
- T**
- Taillights, Changing
- Bulbs 200, 201
- Taking Care of the Unexpected .. 215
- Technical Descriptions
- DOT Tire Quality Grading 244
 - Emissions Control Systems..... 247
 - Oxygenated Fuels..... 150
 - State Emissions Testing 250
 - Three Way Catalytic Converter..... 249
- Tire Labeling..... 246
- Temperature Gauge 65
- Tether Anchorage Points 47
- Theft Protection..... 142
- Three Way Catalytic Converter... 249
- Time, Setting the 119
- Tire Chains 211
- Tire, How to Change a Flat 217
- Tire Information 244
- Tires 207
- Air Pressure 208
 - Checking Wear 209
 - Compact Spare..... 216
 - DOT Tire Quality Grading 244
 - Inflation..... 207
 - Inspection 209
 - Maintenance..... 209
 - Replacing 210
 - Rotating..... 210
 - Snow 211
 - Specifications 243
 - Tire Chains 211
- Tools, Tire Changing 217
- Towing
- A Trailer..... 175
 - Emergency Towing 237
- Traction Devices..... 211

CONTINUED

Index

Transmission	
Checking Fluid Level,	
Automatic	195
Fluid Selection	195, 196
Identification Number	241
Shifting the Automatic	166
Treadwear	244
Trip Meter	66
Trunk.....	86
Opening.....	86
Open Monitor Light	60
Turn Signals	73

U

Unexpected, Taking Care	
of the	215
Uniform Tire Quality Grading	244
Unleaded Gasoline.....	150
Used Oil, How to Dispose of	192

V

Vanity Mirror	95
Vehicle Capacity Load	159
Vehicle Dimensions.....	242

Vehicle Identification Number.....	240
Vehicle Storage	213
Ventilation	103
VIN	240
Viscosity, Oil.....	189

W

WARNING, Explanation of	iii
Warning Labels, Location of	53
Warranty Coverages	253
Washer, Windshield	
Checking the Fluid Level	194
Indicator	61
Operation	72
Wheels	
Adjusting the Steering	75
Alignment and Balance	209
Cleaning	207
Compact Spare	216
Nut Wrench.....	217
Windows	
Operating the Power	92
Rear, Defogger	75
Windshield	
Cleaning	72

Defroster	104
Washers	72
Wipers, Windshield	
Changing Blades.....	204
Operation	72
Worn Tires	207
Wrecker, Emergency Towing.....	237

Service Information Summary

Gasoline:

Unleaded gasoline, pump octane number of 87 or higher.

Fuel Tank Capacity:

12.3 US gal (46.6 ℓ)

Recommended Engine Oil:

API Premium grade 0W-20 detergent oil (see page [189](#)).

Oil change capacity (including filter):

3.4 US qt (3.2 ℓ)

Automatic Transmission Fluid (CVT):

Use Honda CVT Fluid (Continuously Variable Transmission Fluid) only

Capacity:

3.0 US qt (2.8 ℓ)

Brake Fluid:

Honda Heavy Duty Brake Fluid DOT 3 preferred, or a DOT 3 or DOT 4 brake fluid as a temporary replacement (see page [196](#)).

Tire Pressure (measured cold):

Front/Rear:

32 psi (220 kPa , 2.2 kgf/cm²)

Spare Tire:

60 psi (420 kPa , 4.2 kgf/cm²)