



SL

Owner's Manual



Mercedes-Benz

Nur für internen Gebrauch / For internal use only

Symbols

In this Owner's Manual, you will find the following symbols:

WARNING

Warning notices draw your attention to hazards that may endanger your health or life, or the health or life of others.

Environmental note

Environmental notes provide you with information on environmentally aware actions or disposal.

 Notes on material damage alert you to dangers that could lead to damage to your vehicle.

 This symbol indicates useful instructions or further information that could be helpful to you.

▶ This symbol designates an instruction you must follow.

▶ Several consecutive symbols indicate an instruction with several steps.

(▷ page) This symbol tells you where you can find further information on a topic.

▷▷ This symbol indicates a warning or an instruction that is continued on the next page.

Display This text indicates a message on the multifunction/COMAND display.

Welcome to the world of Mercedes-Benz

Before you first drive off, read this Owner's Manual carefully and familiarise yourself with your vehicle. For your own safety and a longer vehicle life, follow the instructions and warning notices in this manual. Disregarding them may lead to damage to the vehicle or personal injury.

The equipment or model designation of your vehicle may vary according to:

- model
- order
- country variant
- availability

The illustrations in this manual show a left-hand-drive vehicle. On right-hand-drive vehicles, the layout of components and controls differs accordingly.

Mercedes-Benz is constantly updating its vehicles to the state of the art.

Mercedes-Benz therefore reserves the right to introduce changes in the following areas:

- design
- equipment
- technical features

The equipment in your vehicle may therefore differ from that shown in the descriptions and illustrations.

The following are integral components of the vehicle:

- Owner's Manual
- Service Booklet
- Equipment-dependent supplements

Keep printed copies of the documents in the vehicle at all times. If you sell the vehicle, always pass the documents on to the new owner.

i You can get to know the important features of your vehicle in the interactive Owner's Manual on the Internet at:

**[http://www.mercedes-benz.de/
betriebsanleitung](http://www.mercedes-benz.de/betriebsanleitung)**

The technical documentation team at Daimler AG wishes you safe and pleasant motoring.



Index	4	Introduction	35
Digital Owner's Manual	30	At a glance	41
		Safety	53
		Opening and closing	83
		Seats, steering wheel and mirrors ..	111
		Lights and windscreen wipers	125
		Climate control	139
		Driving and parking	151
		On-board computer and displays	221
		COMAND Online	281
		Stowing and features	511
		Maintenance and care	529
		Breakdown assistance	543
		Wheels and tyres	561
		Technical data	583

- 1, 2, 3 ...**
- 12 V socket**
see Socket
- A**
- ABS (Anti-lock Braking System)**
Display message 242
Function/notes 73
Important safety notes 73
Warning lamp 271
- Access data of the mobile phone network provider**
Deleting 425
Editing 425
Making entries 422
Selecting 421
- Activating/deactivating air-recirculation mode** 146
- Activating/deactivating cooling with air dehumidification** 142
- Active Blind Spot Assist**
Activating/deactivating (on-board computer) 232
Display message 257
Function/notes 214
- Active Body Control (AMG vehicles)**
Driving conditions menu in the COMAND display (AMG vehicles) ... 200
Function/notes 198
- Active Body Control (AMG Vehicles)**
Display message 255
- Active Body Control (except AMG vehicles)**
Driving conditions menu in the COMAND display 198
Function/notes 196
- Active Body Control (except AMG Vehicles)**
Display message 255
- Active Driving Assistance package** . 213
- Active Lane Keeping Assist**
Activating/deactivating (on-board computer) 232
Display message 257
Function/notes 217
- Active light function** 131
- Active Park Assist**
Display message 258
- Active Parking Assist**
Function/notes 205
Important safety notes 204
- Active partition (USB mass storage devices only)**
Selecting 469
- ADAPTIVE BRAKE** 78
- Adaptive brake lamps** 74
- Adaptive Damping System**
Function/notes 195
- Adaptive Highbeam Assist**
Display message 252
Function/notes 132
- Adaptive Main-beam Assist**
Switching on/off (on-board computer) 235
- Additives (engine oil)** 591
- Address book**
Browsing 406
Calling up 406
Changing an entry 408
Connecting a call 409
Creating an entry 407
Deleting an entry 407
Deleting contacts 412
Details about an entry 408
Entering characters 298
Entry as a home address 359
Hiding contact details 413
Importing contacts 411
Introduction 406
Receiving vCards 412
Searching for an entry 407
Starting route guidance 409
Voice tag 410
- Address entry menu** 318
- Adjusting the balance** 295
- Adjusting the bass** 295

- Adjusting the brightness (TV, video)** 493
- Adjusting the colour (TV, video)** 493
- Adjusting the contrast (TV, video)** ... 493
- Adjusting the sound settings**
- Balance 295
 - Treble and bass 295
- Adjusting the treble (sound)** 295
- Adjusting the vehicle height**
- Active Body Control (AMG vehicles) 198
 - Active Body Control (except AMG vehicles) 196
- Adjusting the volume**
- COMAND 294
 - Navigation messages 294
 - Traffic announcements 294
- Airbag**
- Headbag 59
- Airbags**
- Front airbag (driver, front passenger) 58
 - Important safety guidelines 56
 - Sidebag 58
 - Triggering 55
- Air-conditioning system**
- see Climate control
- AIR FLOW** 143
- AIRSCARF**
- Setting the vents 149
 - Switching on/off 117
- Air vents**
- Glove compartment 149
 - Important safety notes 148
 - Setting 148
 - Setting the AIRSCARF vents 149
 - Setting the centre air vents 148
 - Setting the side air vents 149
 - Switching AIRSCARF on/off 117
 - see Climate control
- Alarm system**
- see ATA (Anti-Theft Alarm system)
- Alternative route** 349
- Ambient lighting**
- Setting the brightness (on-board computer) 235
 - Setting the colour (on-board computer) 235
- AMG**
- Button for AMG menu 166
 - SETUP 166
- AMG menu (on-board computer)** 238
- Anti-glare film** 527
- Anti-lock braking system**
- see ABS (Anti-lock Braking System)
- Anti-Theft Alarm system**
- see ATA (Anti-Theft Alarm system)
- Aquaplaning** 177
- Ashtray** 517
- Assistance menu (on-board computer)** 231
- ASSYST PLUS**
- Displaying a service message 535
 - Hiding a service message 535
 - Resetting the service interval display 535
 - Service message 534
 - Special service requirements 535
- ATA (Anti-Theft Alarm system)**
- Activating/deactivating 80
 - Function 80
 - Interior motion sensor 82
 - Switching off the alarm 80
 - Tow-away protection 81
- ATTENTION ASSIST**
- Activating/deactivating 232
 - Display message 256
 - Function/notes 211
- Audio**
- Radio mode 453
- Audio DVD**
- Pause function 465
 - Playback options 469
 - Safety notes 459
 - Setting the audio format 469
 - Stop function 465
 - Switching to 463
- Audio menu (COMAND Online)** 454
- Audio menu (on-board computer)** ... 228

- AUTO lights**
 Display message 251
 see Lights
- Automatic engine start (ECO start/stop function)** 158
- Automatic engine switch-off (ECO start/stop function)** 157
- Automatic headlamp mode** 127
- Automatic transmission**
 Accelerator pedal position 164
 Automatic drive program 166
 Changing gear 164
 Display message 265
 Driving tips 164
 Emergency running mode 170
 Engaging the park position 161
 Kickdown 165
 Manual drive program 168
 Overview 161
 Problem (fault) 170
 Program selector button 165
 Pulling away 156
 Selector lever 161
 Shift ranges 167
 Starting the engine 155
 Steering wheel gearshift paddles ... 166
 Transmission position display 163
 Transmission positions 164
- Automatic transmission emergency running mode** 170
- AUX (audio)**
 Notes/socket 491
 Switching to 491
- AUX (video)**
 Connecting an external video source 506
 Setting the volume and sound 507
 Showing/hiding the menu 507
 Switching to 507
- Avoiding an area** 370
- B**
- Back button** 291
- BAS (Brake Assist System)** 73
- BAS PLUS (Brake Assist System PLUS)** 73
- Battery (key)**
 Checking 87
 Important safety notes 87
 Replacing 87
- Battery (vehicle)**
 Charging 552
 Display message 254
 Important safety notes 550
 Jump starting 553
 Overview 550
- Belt force limiters (activation)** 55
- Belt tensioner**
 Activation 55
 Function 64
- Bird's-eye view (navigation)** 365
- Blind Spot Assist**
 see Active Blind Spot Assist
- Bluetooth®**
 Activating/deactivating 306
 Activating audio mode 483
 Conditions (telephone) 381
 Connecting another mobile phone . 385
 Connecting audio devices 479
 Device list 480
 Entering the passcode 383
 External authorisation 384
 General information 306
 Interface 378
 Introduction 378
 Reconnecting an audio device 481
 Searching for a mobile phone 382
 Settings 306
 Telephone basic menu 386
 Telephony 381
 Telephony notes 378
- Bluetooth® audio basic display** 483
- Bonnet**
 Active bonnet (pedestrian protection) 530
 Closing 531
 Display message 266
 Important safety notes 530
 Opening 531
- Boot**
 Emergency release 98
 Important safety notes 93
 Locking separately 97

Opening/closing (automatically from inside)	97
Opening/closing (automatically from outside)	95
Opening/closing (from the outside, HANDS-FREE ACCESS)	95
Opening/closing (manually from outside)	94
Overview	93
Boot lid	
Display message	265
Opening/closing	93
Opening dimensions	593
Boot load (maximum)	593
Boot separator	
Display message	266
Fitting	105
General notes	104
Opening/closing	105
Removing	105
Bottle holders	517
Brake Assist System	
see BAS (Brake Assist System)	
Brake fluid	
Display message	247
Notes	591
Brake lamps	
Adaptive	74
Display message	250
Brakes	
ABS	73
BAS	73
BAS PLUS	73
Brake fluid (notes)	591
Display message	242
Driving tips	175
High-performance brake system	176
Important safety notes	175
Parking brake	173
Warning lamp	271
Breakdown	
see Flat tyre	
see Towing away	
Buttons on the COMAND controller	291

C

Call

Accepting/ending/rejecting	391
Connecting	391
see Telephone	

Calling up a fault

see Display messages	
----------------------	--

Call list

Display details	400
-----------------------	-----

Call lists

Deleting	401
Opening and selecting an entry	399
Saving an entry in the address book	400

Capacities (technical data)**Car**

see Vehicle	
-------------	--

Care

Automatic car wash	536
Carpets	541
Display	540
Exhaust pipe	540
Exterior lighting	539
Gear or selector lever	540
High-pressure cleaner	537
Interior	540
Matt paintwork	538
Notes	535
Paint	537
Plastic trim	540
Reversing camera	539
Roof lining	541
Seat belt	541
Seat cover	541
Sensors	539
Steering wheel	540
Trim pieces	541
Washing by hand	536
Wheels	538
Windows	538
Wiper blades	539
Wooden trim	541

Car key

see Key	
---------	--

Car wash (care)**Category list (music search)**

- CD**
- Copy protection 471
 - Fast forward/fast rewind 467
 - General information 471
 - Inserting 460
 - Multisession 470
 - Notes on compact discs 471
 - Pause function 465
 - Player/changer operation (COMAND) 460
 - Safety notes 459
 - Selecting a media type 465
 - Selecting a track 466
 - Sound settings (balance, bass, treble) 294
 - Switching to 463
- CD/DVD**
- Ejecting (DVD drive) 461
 - Ejecting (DVD single drive) 460
 - Inserting (DVD changer) 460
 - Inserting (DVD single drive) 460
- CD mode**
- Playback options 469
- CD player/CD changer(on-board computer)** 228
- Central locking**
- Automatic locking (on-board computer) 236
 - Locking/unlocking (key) 85
- Centre console**
- Lower section 49
 - Lower section (AMG vehicles) 50
 - Upper section 48
- Changing direction**
- Announcement phase 343
 - Change of direction phase 343
 - Preparation phase 343
- Changing the character set** 302
- Changing the picture format (TV, video)** 493
- Character**
- Changing the character set 299
 - Changing the language 299
 - Deleting 300
 - Moving the cursor 300
 - Switching to letters 299
- Characters**
- Entering 300
 - Entering (address book, phone book) 298
 - Entering (navigation) 300
- Charge maintenance socket** 520
- Children**
- In the vehicle 64
 - Restraint systems 64
- Child seat**
- Automatic recognition 66
 - ISOFIX 67
 - On the front-passenger seat 65
 - Problem (malfunction) 69
 - Recommendations 71
 - Suitable positions 69
- Cigarette lighter** 518
- Cleaning**
- Mirror turn signal 539
- Climate control**
- Controlling automatically 143
 - Convenience opening/closing (air-recirculation mode) 147
 - Cooling with air dehumidification . . 142
 - Demisting the windows 146
 - Demisting the windscreen 145
 - Important safety notes 140
 - Indicator lamp 143
 - Notes on using THERMOTRONIC automatic climate control 141
 - Overview of systems 140
 - Problems with cooling with air dehumidification 143
 - Problem with the rear window heating 146
 - Setting the air distribution 144
 - Setting the airflow 145
 - Setting the air vents 148
 - Setting the climate mode (AIR FLOW) 143
 - Setting the temperature 144
 - Switching air-recirculation mode on/off 146
 - Switching on/off 142
 - Switching residual heat on/off 148
 - Switching the rear window heating on/off 146

- Switching the ZONE function on/off 145
- THERMOTRONIC (2-zone) automatic climate control 141
- Cockpit**
 - Overview 42
 - see Instrument cluster
- Collapsible emergency spare wheel**
 - see Emergency spare wheel
- COMAND controller** 291
- COMAND control panel** 289
- COMAND display**
 - Cleaning 540
 - Cleaning instructions 287
 - Driving conditions menu (AMG vehicles) 200
 - Driving conditions menu (except AMG vehicles) 198
 - Setting 303
 - Switching on/off 287
- COMAND Online**
 - Active multicontour seat 311
 - Basic functions 293
 - Calling up drive status regulator (ABC) 310
 - Display 284
 - Emergency call system displays 418
 - Examples of operation 291
 - Importing POIs 433
 - Menu overview 286
 - Multicontour seat 311
 - Seat functions 310
 - Settings 452
 - Switching on/off 293
- COMAND Online and Internet**
 - see Online and Internet functions
- Combination switch** 129
- Compass function** 373
- Connecting a USB device** 463
- Consumption statistics (on-board computer)** 225
- Contacts**
 - Deleting 412
 - Importing 411
- Convenience closing feature** 100
- Convenience opening/closing (air-recirculation mode)** 147
- Convenience opening feature**
 - see Side windows
- Convenience telephony**
 - Overview 386
 - Text message (SMS) 403
 - Transferring a call 395
- Coolant (engine)**
 - Checking the level 533
 - Display message 252
 - Important safety notes 592
 - Temperature (on-board computer) . 238
 - Temperature gauge 222
 - Warning lamp 277
- Cooling**
 - see Climate control
- Copy protection (CD/DVD)** 471
- Cornering light function**
 - Display message 250
 - Function/notes 131
- Crash-responsive emergency lighting** 134
- Cruise control**
 - Cruise control lever 178
 - Deactivating 180
 - Display message 259
 - Driving system 178
 - Important safety notes 178
 - LIM indicator lamp 178
 - Selecting 179
 - Setting a speed 180
 - Storing and maintaining current speed 179
- Cup holder**
 - Centre console 516
 - Important safety notes 516

D

- DAB radio (Digital Audio Broadcasting)**
 - Selecting a station 455
 - see Radio
- Dashboard lighting**
 - see Instrument cluster lighting
- Data**
 - see Technical data

- Data carrier**
 - Audio DVD 470
 - MUSIC REGISTER 475
- Daytime driving lights**
 - Display message 251
 - Function/notes 127
 - Switching on/off (on-board computer) 234
- Dealership**
 - see Qualified specialist workshop
- Declarations of conformity** 38
- Delayed switch-off**
 - Exterior lighting (on-board computer) 235
 - Interior lighting 236
- Delete button** 292
- Destination**
 - Assigning a destination to an address book entry 361
- Destination (navigation)**
 - Displaying information 350
 - Entering a destination by address .. 317
 - Entering a destination using the map 325
 - Entering an intermediate stop 326
 - Entering a POI 330
 - Entering using geo-coordinates 326
 - Saving 360
 - Selecting from the destination memory 323
 - Selecting from the list of last destinations 324
 - Selecting storage options 361
 - Storing after destination entry 360
 - Storing during route guidance 360
- Destination memory (navigation)**
 - Deleting an entry 362
 - Entering/saving your home address 321
 - Previous destinations 362
- Diagnostics connection** 38
- Dialling a number (telephone)** 391
- Digital Owner's Manual**
 - Installation 30
 - Introduction 30, 31
 - Operating notes 31
- Digital speedometer** 226
- Digital TV channels**
 - Programme preview 498
- Dipped-beam headlamps**
 - Display message 250
 - Setting for driving abroad (symmetrical) 126
 - Setting for driving on the right/left 234
 - Switching on/off 127
- Disc**
 - CD/DVD 471
 - MP3 470
- DISC button**
 - Activating audio CD/DVD or MP3 mode 463
 - Activating Bluetooth® Audio 483
 - Switching on the Media Interface . . 486
 - Switching to the MUSIC REGISTER 475
- Display**
 - Selecting the design 303
- Displaying the arrival time** 350
- Displaying the distance to the destination** 350
- Displaying the track and album** 469
- Display message**
 - ASSYST PLUS 534
 - General information 241
 - Hiding (on-board computer) 241
 - KEYLESS-GO 268
- Display messages**
 - Calling up (on-board computer) 241
 - Driving systems 255
 - Engine 252
 - Key 268
 - Lights 250
 - Safety systems 242
 - Tyres 261
 - Vehicle 265
- Distance display (on-board computer)** 231
- Distance recorder**
 - see Trip meter
- Distance warning signal (warning lamp)** 279

- DISTRONIC PLUS**
- Cruise control lever 183
 - Deactivating 188
 - Display message 258
 - Displays in the multifunction display 188
 - Driving tips 189
 - Function/notes 182
 - Important safety notes 181
 - Selecting 183
 - Setting the specified minimum distance 187
 - Warning lamp 279
- Dolby® Digital** 295
- Door**
- Automatic locking (on-board computer) 236
 - Automatic locking (switch) 92
 - Central locking/unlocking (key) 85
 - Control panel 52
 - Display message 266
 - Emergency locking 93
 - Emergency unlocking 92
 - Important safety notes 90
 - Opening (from the inside) 90
 - Power closing 92
- Doors**
- Overview 90
- Draught stop**
- Electrical draught stop 107
 - Manual draught stop 106
- Drive program**
- Automatic 166
 - Display 163
 - Manual 168
- Drive program selector** 165
- Driver's door**
- see Door
- Drive system**
- Active Blind Spot Assist 213
- Driving abroad**
- Service24h 535
 - Symmetrical dipped beam 126
- Driving on flooded roads** 177
- Driving safety system**
- BAS PLUS (Brake Assist System PLUS) 73
 - Electronic Brake-force Distribution 78
 - ESP® (Electronic Stability Program) 75
 - Important safety guidelines 72
- Driving safety systems**
- ABS (Anti-lock Braking System) 73
 - ADAPTIVE BRAKE 78
 - Adaptive brake lamps 74
 - BAS (Brake Assist System) 73
 - ETS (Electronic Traction System) 75
 - Overview 72
 - PRE-SAFE® Brake 78
 - Steering assistant STEER CONTROL 80
- Driving system**
- Active Body Control (AMG vehicles) 198
 - Active Body Control (except AMG vehicles) 196
 - Active Lane Keeping Assist 216
 - Active Parking Assist 204
 - Adaptive Damping System 195
- Driving systems**
- Active Driving Assistance package 213
 - ATTENTION ASSIST 211
 - Cruise control 178
 - Display message 255
 - Distronic Plus 181
 - HOLD function 193
 - PARKTRONIC 201
 - RACE START (AMG vehicles) 194
 - Reversing camera 208
 - Speed Limit Assist 212
 - SPEEDTRONIC 190
- Driving tips**
- AMG ceramic brakes 176
 - Aquaplaning 177
 - Automatic transmission 164
 - Brakes 175
 - DISTRONIC PLUS 189
 - Downhill gradient 175
 - Driving abroad 126

- Driving in winter 177
 - Driving on flooded roads 177
 - Driving on wet roads 177
 - Fuel 175
 - General 175
 - Icy road surfaces 177
 - Limited braking efficiency on salted roads 176
 - New brake pads/linings 176
 - Running-in tips 152
 - Snow chains 565
 - Symmetrical dipped beam 126
 - Wet road surface 176
 - DTMF tone transmission** 393
 - DVD**
 - Copy protection 471
 - Fast forward/fast rewind 467
 - Inserting 460
 - Notes on discs 471
 - Selecting a media type 465
 - Selecting a track 466
 - Sound settings (balance, bass, treble) 294
 - DVD audio**
 - Operating (on-board computer) 228
 - DVD video**
 - Operating (on-board computer) 229
 - Dynamic route guidance/TMC**
 - Displaying traffic reports 356
 - Displays on the map 355
 - Introduction 355
 - Switching on/off 355
- E**
- EASY-ENTRY feature**
 - Activating/deactivating 237
 - Function/notes 118
 - EASY-EXIT feature**
 - Crash-responsive 119
 - Function/notes 118
 - Switching on/off 237
 - EBD (electronic brake force distribution)**
 - Display message 244
 - Function/notes 78
 - ECO start/stop function**
 - Automatic engine start 158
 - Automatic engine switch-off 157
 - Deactivating/activating 158
 - General information 157
 - Important safety notes 156
 - Electrical fuses**
 - see Fuses
 - Electronic Stability Program**
 - see ESP® (Electronic Stability Program)
 - Emergency call 999 or 112** 380
 - Emergency key**
 - Unlocking the driver's door 92
 - Emergency key element**
 - Function/notes 86
 - Locking vehicle 93
 - Emergency release**
 - Driver's door 92
 - Emergency spare wheel**
 - Important safety notes 579
 - Inflating the collapsible spare wheel 581
 - Points to remember 580
 - Removing 580
 - Technical data 582
 - Emergency unlocking**
 - Vehicle 92
 - Engine**
 - Display message 252
 - ECO start/stop function 156
 - Engine number 587
 - Jump-starting 553
 - Running irregularly 160
 - Starting problems 160
 - Starting the engine with the key 155
 - Starting with KEYLESS GO 155
 - Stopping 173
 - Tow-starting (vehicle) 558
 - Warning lamp (engine diagnostics) 276
 - Engine electronics**
 - Notes 585
 - Problem (fault) 160
 - Engine oil**
 - Additives 591
 - Checking the oil level 532

- Checking the oil level using the dipstick 532
- Display message 254
- Filling capacity 591
- Notes about oil grades 590
- Notes on oil level/consumption 532
- Temperature (on-board computer) . 238
- Topping up 532
- Viscosity 591
- Entering a junction name** 321
- Entering an address (example)** 317
- Entering a street name** 318
- Entering the house number** 318
- Entering the town** 318
- Entry**
- Deleting 302
- Saving 299
- Environmental protection**
- Returning an end-of-life vehicle 36
- ESP® (Electronic Stability Program)**
- AMG menu (on-board computer) ... 238
- Deactivating/activating (AMG vehicles) 76
- Deactivating/activating (notes; except AMG vehicles) 76
- Display message 242
- ETS 75
- Function/notes 75
- Important safety guidelines 75
- Warning lamp 273
- ETS (Electronic Traction System)** 75
- Example display**
- Audio CD mode 464
- MUSIC REGISTER 475
- Exhaust pipe (cleaning instructions)** 540
- Exterior lighting**
- Settings options 126
- see Lights
- Exterior mirrors**
- Adjusting 119
- Anti-dazzle mode (automatic) 121
- Folding in/out (automatically) 120
- Folding in/out (electrically) 120
- Folding in when locking (on-board computer) 237
- Out of position (troubleshooting) ... 121
- Parking position 121
- Resetting 120
- Storing settings (memory function) 122
- F**
- Factory setting (reset function)** 308
- Fast forward**
- Audio mode (CD, DVD, MP3) 467
- Video DVD 503
- Fast rewind**
- Audio mode (CD, DVD, MP3) 467
- Video DVD 503
- Fault message**
- see Display messages
- Favourites (Internet)** 449
- Favourites button** 306
- Filler cap**
- see Fuel filler flap
- Fire extinguisher** 545
- First-aid kit** 544
- Fitting a wheel**
- Removing a wheel 573
- Fitting wheels**
- Fitting a wheel 574
- Lowering the vehicle 574
- Preparing the vehicle 571
- Raising the vehicle 572
- Securing the vehicle against rolling away 571
- Flat tyre**
- MOExtended tyres 546
- Preparing the vehicle 546
- TIREFIT kit 547
- see Emergency spare wheel
- Floormat** 526
- Foglamps**
- Extended range 132
- Frequencies**
- Garage door opener 523
- Mobile phone 585
- Two-way radio 585
- Frequency**
- Adjusting for radio stations 457
- Front-passenger seat**
- Adjusting from the driver's seat 114

- Fuel**
- Additives 589
 - Consumption statistics 225
 - Displaying consumption 309
 - Displaying the current consumption 226
 - Displaying the range 226
 - Driving tips 175
 - Fuel gauge 44
 - Grade (petrol) 588
 - Important safety notes 587
 - Notes about consumption 590
 - Notes for AMG vehicles 589
 - Problem (malfunction) 172
 - Refuelling 170
 - Tank content/reserve fuel 588
- Fuel filler flap**
- Opening/closing 171
- Fuel level**
- Calling up the range (on-board computer) 226
 - Gauge 44
- Fuel reserve**
- see Fuel
- Fuel tank**
- Capacity 588
 - Problem (malfunction) 172
- Fuse allocation chart (vehicle tool kit)** 545
- Fuses**
- Allocation chart 558
 - Before changing 558
 - Dashboard fuse box 558
 - Fuse box in the engine compartment 559
 - Fuse box in the rear compartment . 559
 - Important safety notes 558
- G**
- Garage door opener**
- Clearing the memory 523
 - Frequencies 523
 - Important safety notes 521
 - Opening/closing the garage door .. 523
 - Programming (button in the rear-view mirror) 521
- Gear indicator (on-board computer)** 238
- Gearshift program**
- SETUP (on-board computer) 238
- Genuine Mercedes-Benz parts** 584
- Glass roof (sunblind)** 108
- Glove compartment** 512
- Google™ local search**
- Importing a destination/route 429
 - Popular searches 430
 - Search 428
 - Search history 430
 - Selecting a search position 428
 - Using as the destination 429
- GPS reception** 315
- Gracenote® Media Database** 467
- H**
- Handbrake**
- see Parking brake
- HANDS-FREE ACCESS** 95
- Hands-free microphone, switching on/off** 392
- Harman/kardon® Logic 7® surround sound system**
- see Surround sound (harman/kardon® surround sound system)
- Hazard warning lamps**
- Display message 267
 - Switching on/off 130
- Headbag**
- Display message 249
 - Operation 59
- Heading up (navigation)** 365
- Headlamp**
- Cleaning system (function) 130
 - Cleaning system (notes) 593
- Headlamps**
- Misting up 133
 - Topping up the cleaning system 534
 - see Automatic headlamp mode
- Head level heating (AIRSCARF)** 117

- Head restraints**
 Adjusting 115
 see NECK-PRO head restraints
- Heating**
 see Climate control
- High-pressure cleaners** 537
- Hill start assist** 156
- HOLD function**
 Deactivating 194
 Display message 256
 Function/notes 193
- Home address**
 Entering and saving 321
 Selecting from the destination
 memory 323
- I**
- Ignition lock**
 see Key positions
- Immobiliser** 80
- Indicator and warning lamps**
 Coolant 277
 DISTRONIC PLUS 279
 Engine diagnostics 276
 SPORT handling mode 274
- Indicator lamps**
 Display message 250
 see Warning and indicator lamps
- Inspection**
 see ASSYST PLUS
- Instrument cluster**
 Overview 44
 Warning and indicator lamps 46
- Instrument cluster lighting** 222
- Intelligent Light System**
 Activating/deactivating 234
 Display message 251
 Overview 131
 Setting the dipped-beam head-
 lamps for driving on the right/left . 234
- Interface (USB, iPod®)**
 see Media Interface
- Interior lighting** 133
 Automatic control system 134
 Delayed switch-off (on-board
 computer) 236
 Emergency lighting 134
 Manual control 134
 Overview 133
 Reading lamp 133
 Setting the ambient lighting
 brightness (on-board computer) 235
 Setting the ambient lighting col-
 our (on-board computer) 235
- Interior motion sensor** 82
- Intermediate stop**
 Deleting 327
 Entering 326
- Internet**
 Calling up the carousel view 444
 Conditions for access 418
 Creating a favourite 449
 Entering the URL 444
 Favourites manager 449
 Favourites menu 450
 Menu functions 447
 Opening favourites 449
 Selecting/setting access data 420
 Selecting favourites 445
- iPod®**
 Alphabetic track selection 489
 Connecting to Media Interface 485
 Selecting a category/playlist 488
- ISOFIX child seat securing system** 67
- iTunes®** 489
- J**
- Jack**
 Storage location 545
 Using 572
- Jump-start (engine)**
 see Jump starting (engine)
- Jump starting (engine)** 553
- K**
- Key**
 Changing the battery 87
 Checking the battery 87
 Convenience opening feature 100
 Display message 268
 Door central locking/unlocking 85
 Emergency key element 86
 Important safety notes 84

- Loss 89
 - Modifying the programming 86
 - Opening/closing the roof 104
 - Overview 84
 - Positions (ignition lock) 153
 - Problem (malfunction) 89
 - Starting the engine 155
 - KEYLESS-GO**
 - Convenience closing 100
 - Display message 268
 - Locking 85
 - Start/Stop button 153
 - Starting the engine 155
 - Unlocking 85
 - Key positions**
 - Key 153
 - KEYLESS GO 153
 - Kickdown**
 - Driving tips 165
 - Manual drive program 169
- L**
- Lamps**
 - see Warning and indicator lamps
 - Lane Keeping Assist**
 - see Active Lane Keeping Assist
 - Lane recommendations**
 - Explanation 345
 - Presentation 345
 - Lap time (RACETIMER) 238**
 - Licence plate lamp (display message) 251**
 - Lighting**
 - see Lights
 - Lights**
 - Activating/deactivating the Intelligent Light System 234
 - Activating/deactivating the interior lighting delayed switch-off 236
 - Active light function 131
 - Automatic headlamp mode 127
 - Cornering light function 131
 - Dipped-beam headlamps 127
 - Driving abroad 126
 - Foglamps (extended range) 132
 - Hazard warning lamps 130
 - Headlamp flasher 130
 - Light switch 126
 - Main-beam headlamps 129
 - Motorway mode 131
 - Parking lamps 129
 - Rear foglamp 128
 - Setting the ambient lighting brightness (on-board computer) 235
 - Setting the ambient lighting colour (on-board computer) 235
 - Side lamps 128
 - Switching Adaptive Highbeam Assist on/off 235
 - Switching the daytime driving lights on/off (on-board computer) . 234
 - Switching the exterior lighting delayed switch-off on/off (on-board computer) 235
 - Switching the surround lighting on/off (on-board computer) 235
 - Turn signals 129
 - see Changing bulbs
 - see Interior lighting
 - Light sensor (display message) 251**
 - LIM indicator lamp**
 - Cruise control 178
 - DISTRONIC PLUS 183
 - Variable SPEEDTRONIC 191
 - Limiting the speed**
 - see SPEEDTRONIC
 - LINGUATRONIC**
 - Settings 305
 - List of access data**
 - New provider 422
 - List of mobile phone network providers**
 - Calling up 420
 - Empty 420
 - With the selected provider 421
 - Load/eject button 460**
 - Loading aid (boot)**
 - Raising/lowering the roof 514
 - Locking**
 - see Central locking
 - Locking (doors)**
 - Automatic 92
 - Emergency locking 93
 - From inside (central locking button) 91

- Locking centrally**
see Central locking
- Locking verification signal (on-board computer)** 236
- Luggage compartment**
Power closing feature 92
- Luggage cover**
see Boot separator
- Lumbar support**
Adjusting (COMAND Online) 311
- M**
- M+S tyres** 564
- MAGIC SKY CONTROL** 108
- Main-beam headlamps**
Display message 251
Switching Adaptive Highbeam Assist on/off 133
Switching on/off 129
- Map (navigation)**
Adjusting the scale 363
Arrival time/distance to the destination 366
City model 368
Geo-coordinate display 366
Heading 365
Information in the display 366
Map settings 364
Moving 364
North orientation 365
Notes 363
POI symbols 365
RDS-TMC displays 355
Road display 366
Saving the crosshair position 364
Showing the map data version 373
Topographical map 368
Updating 374
Updating process 374
- Matt finish (cleaning instructions)** .. 538
- Media Interface**
Alphabetical track selection 489
Basic menu 487
Connecting an external audio source 485
Connecting an external video source 506
Connection options 485
iPod® 485
Mode 485
MP3 player 485
Notes for the MP3 player 491
Playback options 490
Selecting categories 488
Selecting folders 488
Selecting music files 487
Selecting playlists 488
Switching on 486
USB mass storage device 485
- Media list** 465
- Memory card (audio)** 228
- Memory function** 122
- Mercedes-Benz Contact** 414
- Mercedes-Benz emergency call system**
Automatic emergency call 416
Conditions 416
Displays in the COMAND display ... 418
Manual emergency call 417
Overview 415
Service availability in Europe 415
Transmitted data 417
- Mercedes-Benz Service Centre**
see Qualified specialist workshop
- Message memory (on-board computer)** 241
- Messages**
see Display messages
- Microphone, switching on/off** 392
- Mirror**
see Vanity mirror (in sun visor)
- Mirrors**
see Exterior mirrors
see Rear-view mirror
- Mobile phone**
Authorising 383
Connecting (Bluetooth® interface) . 381
Connecting (convenience telephony) 386
De-authorising 385
External authorisation 384
Frequencies 585
Installation 585
Menu (on-board computer) 229

Notes/placing in the bracket	519
Registering (authorising)	383
Transmission output (maximum)	585
Modifying the programming (key)	86
MOExtended tyres	546
Motorway information	368
Motorway mode	131
MP3	
Bit/sampling rates	471
Copyright	471
Disc	470
Fast forward/fast rewind	467
File systems	470
Formats	470
Notes	470
Operating	228
Pause function	465
Playback options	469
Safety notes	459
Selecting a media type	465
Selecting a track	466
Sound settings (balance, bass, treble)	294
Switching to	463
Multicontour seat	311
Multifunction display	
Function/notes	224
Permanent display	233
Multifunction steering wheel	
Adjusting the volume	294
Operating the on-board computer .	223
Overview	47
Selecting a TV channel	495
Multisession CD	470
MUSIC REGISTER	
Copying music data	476
Deleting all music files	477
Deleting individual music files	478
General notes	475
Memory space info	477
Playback options	478
Switching on	475
Music search	472
My address	358

N

Navigation

Adjusting the volume of the navigation announcements	294
Alternative route	349
Avoiding an area	370
Basic settings	316
Blocking a route section affected by a traffic jam	348
Compass function	373
Destination memory	358
Displaying destination information (arrival time, distance to destination)	350
Dynamic route guidance/TMC	355
Entering/saving your home address	321
Entering a destination	317
Entering a destination by address ..	317
Entering a destination using the map	325
Entering an intermediate stop	326
Entering a POI	330
Entering characters (character bar)	300
General notes	315
GPS reception	315
Lane recommendation	345
List of areas	371
Map settings	363
Menu (on-board computer)	226
Motorway information	368
Off-road/off-map (off-road destination)	354
Previous destinations	362
Repeating announcements	347
Route guidance	343
Safety notes	314
Selecting a destination from the destination memory	323
Selecting a destination from the list of last destinations	324
Selecting your home address	323
Setting options for destination/route download	442

- Setting route options (avoiding: motorways, toll roads, tunnels, ferries) 316
 - Setting the route type (short route, fast route, dynamic route or economic route) 316
 - Showing/hiding the menu 316
 - Starting route calculation 321
 - Switching announcements on/off . 347
 - Switching on 315
 - Navigation announcements**
 - Switching off 294
 - NECK-PRO head restraints**
 - Operation 60
 - Resetting after being triggered 61
 - North orientation (navigation)** 365
 - Notes on running in a new vehicle** .. 152
- O**
- Occupant safety**
 - Children in the vehicle 64
 - Important safety notes 54
 - Odometer**
 - see Total distance recorder
 - see Trip meter
 - Off-map** 354
 - Oil**
 - see Engine oil
 - On-board computer**
 - AMG menu 238
 - Assistance menu 231
 - Audio menu 228
 - Convenience submenu 237
 - Displaying a service message 535
 - Display messages 241
 - DISTRONIC PLUS 188
 - Factory setting submenu 233
 - Important safety notes 222
 - Instrument cluster submenu 233
 - Light submenu 234
 - Menu overview 225
 - Message memory 241
 - Navigation menu 226
 - Operating the TV 229
 - Operating video DVD 229
 - Operation 223
 - RACETIMER 238
 - Service menu 232
 - Settings menu 233
 - Standard display 225
 - Telephone menu 229
 - Trip menu 225
 - Vehicle submenu 236
 - Online and Internet functions**
 - Ending the connection 427
 - Establishing/ending the connection 426
 - Further Mercedes-Benz Apps 443
 - Manually setting the access data of the mobile phone network provider 422
 - Mercedes-Benz Mobile Website 443
 - Options menu 439
 - Resetting adjustments 443
 - Selecting options for the local search 439
 - Selecting options for the weather display 440
 - Selecting the access data of the mobile phone network provider 421
 - Setting options for destination/route download 442
 - Specifying the ID for the download 442
 - Operating system**
 - see On-board computer
 - Outside temperature display** 223
 - Overhead control panel** 51
- P**
- Paint code** 586
 - Paintwork (cleaning instructions)** ... 537
 - Panic alarm** 54
 - Parking** 172
 - Engaging park position 161
 - Important safety notes 172
 - Parking brake 173
 - Position of exterior mirror, front-passenger side 121
 - Reversing camera 208
 - see PARKTRONIC

- Parking aid**
 - Active Parking Assist 204
 - see Exterior mirrors
 - see PARKTRONIC
- Parking brake**
 - Display message 245
 - Electric parking brake 173
 - Warning lamp 276
- Parking lamps**
 - Display message 251
 - Switching on/off 129
- PARKTRONIC**
 - Deactivating/activating 203
 - Driving system 201
 - Function/notes 201
 - Important safety notes 201
 - Problem (fault) 204
 - Sensor range 201
 - Warning display 202
- PASSENGER AIRBAG OFF warning lamp** 66
- Pause function**
 - Audio mode (CD, DVD, MP3) 465
 - Video DVD 503
- Personal POIs**
 - Acoustic notification 336
 - Calling up the menu 335
- Personal special destination**
 - Selecting as the destination 338
- Personal special destinations**
 - Displaying on the map 335
 - Managing categories 336
 - Saving 337
 - Settings 335
 - Visual information 335
- Petrol** 588
- Phone book**
 - Adding a number to an address
 - book entry 398
 - Calling up 395
 - Creating a new entry 398
 - Deleting an entry 397
 - Entering characters 298
 - Searching for an entry 396
 - Symbol overview 396
- Picture settings (TV, video)** 493
- Picture viewer**
 - Displaying pictures 508
 - Introduction 507
- PIN**
 - Entering 387
- Plastic trim (cleaning instructions)** . 540
- Playback options**
 - Audio mode (CD, DVD, MP3) 469
- POI (navigation)**
 - Category 332
 - Defining the position for the POI search 331
 - Entering 330
 - Entering a POI using the map 334
 - List 332
- POI icon**
 - Setting 365
- POIs (navigation)**
 - see Personal POIs
- Power closing feature** 92
- Power socket**
 - Boot 519
- Power windows**
 - see Side windows
- PRE-SAFE® (preventive occupant safety system)**
 - Display message 248
 - Operation 60
- PRE-SAFE® Brake**
 - Activating/deactivating 231
 - Display message 248
 - Function/notes 78
 - Warning lamp 279
- Previous destinations (navigation)** .. 362
- Product information** 36
- Program selector button** 165
- Protection of the environment**
 - General notes 36
- Pulling away (automatic transmission)** 156

Q

- Qualified specialist workshop** 38

- R**
- RACE START**
important safety notes 194
- RACETIMER (on-board computer)** 238
- Radar sensors**
Overview 595
- Radar sensor system**
Activating/deactivating 237
Display message 256
- Radio**
Alphabetical browser 455
Overview 453
RDS (Radio Data System) 458
Selecting a station 228
Setting a station 455
Sound settings (balance, bass, treble) 294
Storing stations 457
Switching on 453
Switching wavebands 455
Traffic Programme 458
- Radio station**
Storing 457
- RDS (Radio Data System)**
General notes 458
Switching on/off 458
- Read-aloud function**
Automatic 358
- Reading lamp** 133
- Rear foglamp**
Display message 251
Switching on/off 128
- Rear lamps**
see Lights
- Rear-view mirror**
Anti-dazzle mode (automatic) 121
Dipping (manual) 119
- Rear window heating**
Problem (fault) 146
Switching on/off 146
- Receiving vCards** 412
- Redialling (telephone)** 392
- Refuelling**
Fuel gauge 44
Important safety notes 170
Notes for AMG vehicles 589
Refuelling process 171
see Fuel
- Remote control**
Programming (garage door opener) 521
- Replacing bulbs**
General notes 134
- Reserve (fuel tank)**
see Fuel
- Reserve fuel**
Display message 254
Warning lamp 276
- Reset function** 308
- Resetting (factory settings)** 308
- Residual heat (climate control)** 148
- Restraint system**
see SRS (Supplemental Restraint System)
- Rev counter** 222
- Reverse gear (selector lever)** 161
- Reversing camera**
Cleaning instructions 539
Displaying the image 314
Function/notes 208
Switching on/off 208
- Reversing lamp (display message)** .. 251
- Roll bar**
Display message 248
Operation 59
- Roller sunblind** 108
- Roof**
Display message 267
Important safety notes 102
Opening/closing (with key) 104
Opening/closing (with roof switch) 103
Overview 102
Problem (malfunction) 109
Relocking 104
- Roof lining and carpets (cleaning instructions)** 541
- Roof switch** 103
- Route**
Estimated time of arrival 350

Route (navigation)

Calling up the "Routes" menu	352
Displaying the distance to the destination	350
Recording	351
Route overview	350
Selecting an alternative route	349
Setting route options (avoiding: motorways, toll roads, tunnels, ferries)	316
Setting the route type (short route, fast route, dynamic route or economic route)	316
Starting calculation	321

Route display 351**Route guidance**

Cancel	348
Continue	348
Destination reached	348
General information	343
Lane recommendations	345
Off-road	354

S**Safety**

Children in the vehicle	64
Child restraint systems	64

Safety notes

Audio CD/DVD and MP3 mode	459
Using the telephone	379
Video DVD mode	500

Safety system

see Driving safety system

Saving the crosshair position 364**SD memory card**

Ejecting	463
Inserting	463

Seat

Active multicontour seat	311
Balance (seat heating)	312
Resetting adjustments	314
Seat functions (COMAND Online) ..	310
Selecting for adjustment (COMAND Online)	311

Seat belt

Adjusting the driver's and front-passenger seat belt	63
Belt force limiter	64
Belt tensioner	64
Cleaning	541
Fastening	62
Important safety guidelines	61
Releasing	63
Seat belt guide	115
Switching belt adjustment on/off (on-board computer)	237
Warning lamp	269
Warning lamp (function)	63

Seats

Adjusting (electrically)	114
Adjusting lumbar support (COMAND Online)	311
Adjusting the head restraint	115
Belt guide	115
Cleaning the cover	541
Correct driver's seat position	112
Important safety notes	113
Massage function	313
Multicontour seat	311
Overview	113
Seat heating problem	117
Seat ventilation problem	117
Sliding forward/back	115
Storing settings (memory function)	122
Switching AIRSCARF on/off	117
Switching seat heating on/off	116
Switching the seat ventilation on/off	117

Selecting channels

TV	495
----------	-----

Selecting the country 318**Selector lever**

Cleaning	540
Positions	161

Sensors (cleaning instructions) 539**Service**

see ASSYST PLUS

Service Centre

see Qualified specialist workshop

Service menu (on-board computer) . 232

- Service products**
 - Brake fluid 591
 - Coolant (engine) 592
 - Engine oil 590
 - Fuel 587
 - Important safety notes 587
 - Washer fluid 593
- Service report**
 - see Qualified specialist workshop
- Settings**
 - Basic TV settings 499
 - Factory (on-board computer) 233
 - Menu overview 286
 - On-board computer 233
 - Picture (COMAND) 493
 - Sound settings 294
- Setting the air distribution** 144
- Setting the airflow** 145
- Setting the audio format**
 - Audio DVD 469
 - Video DVD 505
- Setting the date format** 304
- Setting the day design** 303
- Setting the language**
 - COMAND 306
- Setting the night design** 303
- Setting the read-aloud speed** 305
- Setting the volume**
 - Telephone calls 294
 - Video-AUX 507
- SETUP (on-board computer)** 238
- Sidebag** 58
- Side lamps**
 - Switching on/off 128
- Side windows**
 - Convenience closing 100
 - Important safety notes 98
 - Opening/closing (front) 99
 - Opening/closing (rear) 99
 - Opening/closing all 99
 - Overview 98
 - Problem (malfunction) 102
 - resetting 101
- Snow chains** 565
- Socket**
 - Charge maintenance socket 520
 - Front-passenger footwell 518
 - Under the armrest 519
- Sockets**
 - General notes 518
- Sound**
 - Switching on/off 293
- Sound menu** 294
- Sound Modus** 297
- Sound settings**
 - Calling up the sound menu 294
 - Surround sound 295
- Spare wheel**
 - see Emergency spare wheel
- Special destination list**
 - With character bar 333
- Specialist workshop** 38
- Spectacles compartment** 513
- Speed, controlling**
 - see Cruise control
- Speed dial list**
 - Storing a phone book entry in the speed dial list 401
- Speed Limit Assist** 370
 - Activating/deactivating the warning function 231
 - Displaying 231
 - Display message 256
 - Display message in the multifunction display 213
 - Function/notes 212
 - Important safety notes 212
 - Notes (navigation) 370
- Speedometer**
 - Digital 226
 - In the Instrument cluster 44
 - Segments 223
 - Selecting the unit of measurement 233
- SPEEDTRONIC**
 - Deactivating variable 193
 - Display message 259
 - Function/notes 190
 - Important safety notes 190
 - LIM indicator lamp 191
 - Permanent 193

Selecting	191	Glove compartment	512
Storing the current speed	191	Important safety information	512
Variable	191	Rear	514
SPORT handling mode		Stowage net	514
Activating/deactivating (AMG		Stowage space	
vehicles)	76	Display message	266
Warning lamp	274	Stowage net	514
SRS (Supplemental Restraint Sys-		Umbrella holder	513
tem)		Stowage well beneath the boot	
Display message	249	floor	516
Introduction	55	Summer tyres	564
Warning lamp	276	Sun visor	517
Warning lamp (function)	55	Supplemental Restraint System	
Start/stop function		see SRS (Supplemental Restraint	
see ECO start/stop function		System)	
Starting (engine)	155	Surround lighting (on-board com-	
Station list	455	puter)	235
Station pre-sets	456	Surround sound	295
Station search	456	Surround sound (harman/kar-	
STEER CONTROL	80	don® surround sound system)	
Steering (display message)	266	Notes	295
Steering wheel		Switching on/off	296
Adjusting (electrically)	118	Suspension tuning	
Button overview	47	Active Body Control (AMG vehi-	
Buttons (on-board computer)	223	cles)	200
Cleaning	540	Active Body Control (except AMG	
Gearshift paddles	166	vehicles)	197
Important safety notes	118	SETUP (on-board computer)	238
Storing settings (memory func-		Switching between summer and	
tion)	122	standard time	305
Steering wheel gearshift paddles	166	Switching off the alarm (ATA)	80
Stop function		Switching wavelength (radio)	455
Audio DVD	465	System settings	
Video DVD	503	Bluetooth®	306
Stopwatch (RACETIMER)	238	Date	304
Storing channels		Language	306
TV	497	LINGUATRONIC (voice control)	305
Storing stations		Text reader speed	305
Radio	457	Time	304
Stowage areas	512	Time zone	305
Stowage compartment			
Spectacles compartment	513		
Stowage compartments			
Armrest (under)	513		
Centre console	513		
Centre console (rear)	514		
Cup holder	516		

T

Tail lamps

- Display message 250
- see Lights

Technical data

- Capacities 587
- Emergency spare wheel 582
- Notes 584
- Tyres/wheels 575
- Vehicle data 593

Telephone

- Accepting/ending call 391
- Accepting a call 230
- Accepting or rejecting a waiting call 393
- Adjusting the volume for calls 294
- Automatically reconnecting mobile phone 385
- Calling (outgoing call) 391
- Connecting a Mobile phone (general information) 381
- Deregistering (de-authorising) a mobile phone 385
- Display message 267
- Ending an active call 394
- Entering a number 391
- Entering phone numbers 391
- External authorisation (Bluetooth®) 384
- Function restrictions 380
- General notes 378
- Incoming call 391
- Making a call 394
- Making a call via speed dial 392
- Menu (on-board computer) 229
- Number from the phone book 230
- Operating options 380
- Overview of functions 392
- Reception and transmission volume 390
- Redialling 230
- Rejecting/ending a call 230
- Rejecting a call 391
- Safety notes 379
- Sending DTMF tones 393
- Single call 392

- Switching hands-free microphone on/off 392
- Telephone compartment 513
- Text message (SMS) 403
- Toggling 394
- Transferring a call (convenience telephony) 395
- Using the telephone 391
- see Bluetooth®

Telephone basic menu

- Bluetooth® interface 386
- Convenience telephony 388

Telephone mode

- Redialling 392

Telephone number

- Entering 391

Teletext (TV) 499**Temperature**

- Coolant 222
- Coolant (on-board computer) 238
- Engine oil (on-board computer) 238
- Outside temperature 223
- Setting (climate control) 144

TEMPOMAT

- Function/notes 178

Text message (SMS)

- Call sender 405
- Deleting 405
- Inbox 404
- Reading 404
- Reading aloud 404
- Storing sender in address book 405
- Storing the sender as a new address book entry 405

Text messages (SMS)

- Notes and requirements 403

Theft-deterrent system

- ATA (Anti-Theft Alarm system) 80
- Immobiliser 80

Time

- Setting 304
- Setting summer/standard time 305
- Setting the format 304
- Setting the time 304
- Setting the time/date format 304
- Setting the time zone 305

Timing (RACETIMER) 238

- TIREFIT kit** 547
- TMC (Traffic Message Channel)**
 Displays on the map 355
 Switching dynamic route guidance on/off 355
- Tone settings**
 Balance and fader 295
- Total distance recorder** 225
- Tow-away protection** 81
- Towing**
 Important safety notes 555
 With the rear axle raised 557
- Towing away**
 Fitting the towing eye 556
 Removing the towing eye 556
 With both axles on the ground 557
- Tow-starting**
 Emergency engine starting 558
 Important safety notes 555
- Track**
 Selecting (CD, DVD, MP3) 466
 Selecting using the number keypad 466
- Traffic Announcement (TA)**
 Interrupting 459
 Notes 458
 Switching on/off 458
- Traffic jam function** 348
- Traffic jam icon**
 Showing on route 356
- Traffic jam message**
 Reading out on route 358
- Traffic jams**
 Showing in the map 355
- Traffic Message Channel**
 see TMC (Traffic Message Channel)
- Traffic messages**
 see Dynamic route guidance/TMC
- Traffic Programme (TA)**
 Switching off 294
- Traffic reports**
 Reading out on route 358
 Real-time traffic news 357
 Showing in the map 355
 Showing on route 356
 Traffic symbol information 356
- Transmission**
 Selector lever 161
 see Automatic transmission
- Transporting the vehicle** 557
- Travel guide**
 Activating/deactivating data 340
 Calling up 340
 Choosing topics 341
 Exploring a destination or route 342
 Selecting a destination or route on the map 341
 Via Michelin 339
- Trim pieces (cleaning instructions)** . 541
- Trip computer (on-board computer)** 225
- Trip meter**
 Calling up 225
 Resetting (on-board computer) 226
- True Image™** 297
- Turn signal**
 see Turn signals
- Turn signals**
 Switching on/off 129
- TV**
 Alphabetical browser 498
 Automatic picture shutoff 492
 Fixing a channel 499
 Further options 500
 Information about the current programme 497
 Operating (on-board computer) 229
 Picture settings 493
 Programme preview 498
 Reception quality 493
 Selecting channels (COMAND Online) 495
 Setting the reception region 499
 Showing/hiding the menu 495
 Showing/hiding the navigation menu 494
 Sound settings (balance, bass, treble) 294
 Storing channels (COMAND Online) 497
 Switching on 494
 Teletext 499

- Two-way radio**
 Frequencies 585
 Installation 585
 Transmission output (maximum) 585
- Type identification plate**
 see Vehicle identification plate
- Tyre pressure**
 Calling up (on-board computer) 568
 Display message 261
 Not reached (TIREFIT) 549
 Reached (TIREFIT) 549
 Recommended 565
- Tyre pressure loss warning**
 Important safety notes 566
 Restarting 567
- Tyre pressure monitor**
 Function/notes 568
 Restarting 569
 Warning lamp 280
- Tyres**
 Changing a wheel 570
 Checking 563
 Direction of rotation 570
 Display message 261
 Important safety notes 562
 M+S tyres 564
 MOExtended tyres 564
 Overview 562
 Replacing 570
 Service life 563
 Storing 570
 Summer tyres 564
 Tyre size (data) 575
 Tyre tread 563
 see Flat tyre
- U**
- Umbrella holder** 513
- Unladen weight** 593
- Unlocking**
 Emergency unlocking 92
 From inside the vehicle (central
 unlocking button) 91
- Updating the digital map** 374
- USB**
 see Media Interface
- V**
- Vanity mirror (in sun visor)** 517
- Variable SPEEDTRONIC**
 see SPEEDTRONIC
- Vehicle**
 Correct use 39
 Data acquisition 39
 Display message 265
 Electronics 585
 Equipment 37
 Implied warranty 39
 Individual settings 233
 Leaving parked up 174
 Locking (in an emergency) 93
 Locking (key) 85
 Lowering 574
 Pulling away 156
 Raising 572
 Registration 38
 Securing from rolling away 571
 Towing away 555
 Tow-starting 555
 Transporting 557
 Unlocking (in an emergency) 92
 Unlocking (key) 85
 Vehicle data 593
- Vehicle battery**
 see Battery (vehicle)
- Vehicle data** 593
- Vehicle dimensions** 593
- Vehicle emergency locking** 93
- Vehicle identification number**
 see VIN
- Vehicle identification plate** 586
- Vehicle level**
 Active Body Control (AMG vehi-
 cles) 198
 Active Body Control (except AMG
 vehicles) 196
 Display message 255
- Vehicle tool kit** 545
- Vehicle weights** 593
- Video**
 Operating the DVD 229
 see Video DVD
- Video-AUX**
 Setting the picture 493

Video DVD

Automatic picture shutoff	492
Data carrier	501
DVD menu	504
Fast forward/rewind	503
Function restrictions	501
Interactive content	506
Operation	500
Pause function	503
Playing conditions	501
Safety notes	500
Selecting	504
Selecting a film/title	504
Selecting a scene/chapter	503
Setting the audio format	505
Setting the language	505
Setting the picture	493
Showing/hiding the menu	502
Showing/hiding the navigation menu	502
Stop function	503
Subtitles	506
Switching on	501

VIN	586
------------------	-----

W**Warning and indicator lamps**

ABS	271
Brakes	271
Distance warning signal	279
ESP®	273
ESP® OFF	274
Fuel tank	276
LIM (cruise control)	178
LIM (DISTRONIC PLUS)	183
LIM (variable SPEEDTRONIC)	191
Overview	46
PASSENGER AIRBAG OFF	66
Reserve fuel	276
Seat belt	269
SRS	276
Tyre pressure monitor	280

Warning triangle	544
-------------------------------	-----

Washer fluid

Display message	267
-----------------------	-----

Waypoints

Accepting waypoints for the route ..	330
Editing	329
Entering	327

Weather display (COMAND Online)

Calling up the weather map	437
Information chart	434
Selecting locations in the informa- tion chart	435
Selecting the location	435
Selecting the location in the weather map	437
Switching off	434
Switching on	434

Weather map (COMAND Online)

Legend	438
Showing/hiding the menu	437
Switching to the weather informa- tion display	437

Website

Adding to favourites	449
----------------------------	-----

Wheel bolt tightening torque	574
---	-----

Wheel chock	571
--------------------------	-----

Wheels

Changing/replacing	570
Changing a wheel	570
Checking	563
Cleaning	538
Cleaning (warning)	570
Emergency spare wheel	579
Fitting a new wheel	574
Fitting a wheel	571
Important safety notes	562
Overview	562
Removing a wheel	573
Storing	570
Tightening torque	574
Wheel size/tyre size	575

Windows

Cleaning	538
see Side windows	

Windscreen

Demisting	145
-----------------	-----

Windscreen washer fluid

see Windscreen washer system

Windscreen washer system

Notes	593
Topping up	534

Windscreen wipers

- Display message 267
 - Problem (malfunction) 138
 - Replacing the wiper blades 136
 - Switching on/off 135
- see Windscreen

Winter operation

- Important safety notes 564
- Overview 564
- Slippery road surfaces 177
- Snow chains 565

Winter tyres

- Limiting the speed (on-board computer) 236
- M+S tyres 564

Wiper blades

- Cleaning 539
- Important safety notes 136
- Replacing 136

Wooden trim (cleaning instructions)

- 541

Workshop

- see Qualified specialist workshop

Introduction

In addition to the printed Owner's Manual, the vehicle document wallet also contains further operating instructions, such as:

- Digital Owner's Manual on CD
- Service Booklet
- Equipment-dependent supplements

The printed Owner's Manual provides information on selected functions of your vehicle. You can also access the Digital Owner's Manual via COMAND Online. If you have further questions that are not covered in the printed Owner's Manual, please consult the Digital Owner's Manual.

- i** You will not incur any costs when calling up the Digital Owner's Manual. It works without connecting to the Internet.

In the following sections you will find further information about:



- how to operate the Digital Owner's Manual
- the differing access options from the basic menu

There are three options for accessing via the basic menu of the Digital Owner's Manual:

- Visual search
- Keyword search
- Contents

Installation

Check whether or not the Digital Owner's Manual has already been installed. To do so, call up the Digital Owner's Manual via COMAND Online as follows:

- ▶ Using the COMAND controller, select the  symbol from the menu bar in the COMAND display and press  to confirm.
 - ▶ Choose the "Owner's Manual" selection card and confirm with .
- There are two possibilities:

1. The Digital Owner's Manual is installed. The basic menu for the Digital Owner's Manual opens.
2. The Digital Owner's Manual is not installed. The following message appears: **The Owner's Manual has not yet been installed. Please insert the correct disc.**

If the Digital Owner's Manual has not yet been installed, you have the option of installing it yourself. You will find the installation CD required in the vehicle document wallet.

The duration of the installation process may vary.

The installation process takes approximately 25 minutes. This timespan only applies if you install the Digital Owner's Manual while the vehicle is at a standstill and no other COMAND Online functions are in use at the time. The duration of the installation process may increase accordingly if other COMAND Online functions such as navigation or telephony are in use at the time.

If you encounter any problems during installation, please contact your Mercedes-Benz Service Centre.

- ▶ **To install the Digital Owner's Manual:** stop the vehicle safely, paying attention to road and traffic conditions.
- ▶ Turn the key to position **2** in the ignition lock.
- ▶ Switch on COMAND Online.
- ▶ Insert the installation CD into the CD/DVD drive.
- ▶ Follow the installation steps on the COMAND display.

- i** If the check was not successful, a message appears, e.g. **The disc containing the Digital Owner's Manual is not supported by the system. Ejecting disc.** Please contact your Mercedes-Benz Service Centre.

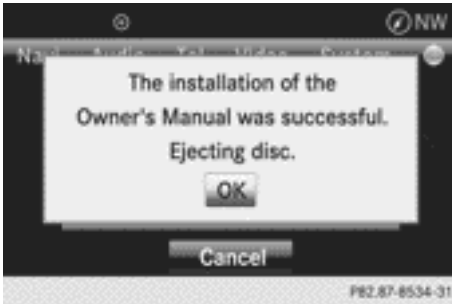

► **When the installation has been completed:** confirm ejection of the installation CD using the COMAND controller.

i **To cancel the installation:** you can cancel the installation of the Digital Owner's Manual during the installation process. The installation can be continued at a later date.

To continue installation: insert the installation CD into the CD/DVD drive again and follow the installation instructions, as described above.

Operating notes

Introduction

In addition to the printed Owner's Manual, the vehicle document wallet also contains further operating instructions, such as:

- Digital Owner's Manual on CD
- Service Booklet
- Equipment-dependent supplements

The printed Owner's Manual provides information on selected functions of your vehicle. You can also access the Digital Owner's Manual via COMAND Online. If you have further questions that are not covered in the printed Owner's Manual, please consult the Digital Owner's Manual.

i You will not incur any costs when calling up the Digital Owner's Manual. It works without connecting to the Internet.

In the following sections you will find further information about:

- how to operate the Digital Owner's Manual
- the differing access options from the basic menu

There are three options for accessing via the basic menu of the Digital Owner's Manual:



- Visual search
- Keyword search
- Contents

Visual search

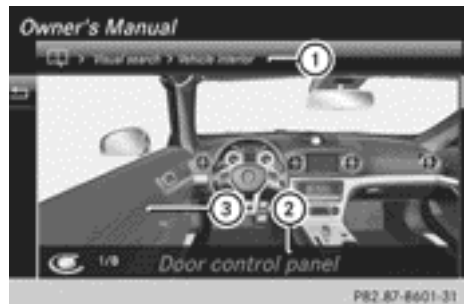
The visual search allows you to explore your vehicle "virtually". Starting from either the vehicle exterior view or interior view, you can access many of the different topics covered by the Owner's Manual. To access the vehicle interior section, select "Interior" on the section heading page.



- ① Topic bar
- ② Selected section heading
- ③ Active vehicle component

► Turn  or slide  the COMAND controller to select individual vehicle components.

Individual vehicle components are highlighted in colour. Just one vehicle component per view is highlighted.

► To confirm the currently selected section, press  the COMAND controller.

After you have selected a section, one of the following happens:

- you go straight to the corresponding section in the Digital Owner's Manual.
 - a list opens up with further, in-depth headings that you can select using the COMAND controller.
 - you go down a level to the visual search. You can refine your search here. Turn **⏏** or slide **←→** the COMAND controller to select individual vehicle components highlighted in red **③**.
- **To return to the previous page:** press the **⏪** button next to the COMAND controller. The previous page opens.

Keyword search

The keyword search allows you to perform a keyword search using character entry. A detailed description of character entry can be found in the section "COMAND Online" under "Character entry (telephony)" (► page 298).

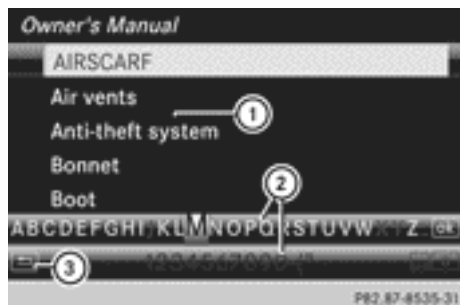

- ① Selection list of available keywords
- ② Character bar
- ③ **⏪** Back symbol

► **To enter a keyword:** turn **⏏** or slide **←→** the COMAND controller to select a

character. Slide **↑↓** the COMAND controller to change the character bar.

- To confirm the character, press **⏏** the COMAND controller. Selection list **①** is then filtered.
- Select characters in the same way until COMAND Online jumps automatically to selection list **①**. Alternatively, you can call up selection list **①** by pressing **OK**.

Contents

In the contents, the topics are listed in the same order as in the printed Owner's Manual. You can select a section and then a subsection.

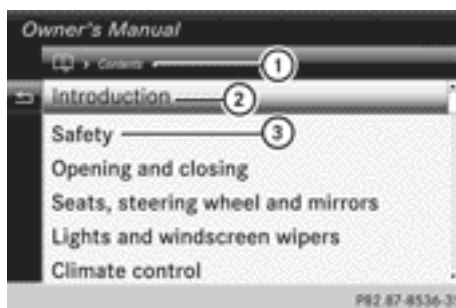

- ① Topic bar
- ② Currently selected section in the contents
- ③ Section not currently selected in the contents

- Turn **⏏** or slide **↑↓** the COMAND controller to select the desired section.
- To confirm the selection, press **⏏** the COMAND controller. A further selection list with the corresponding subsection opens.
- Select the corresponding subsection in the same way.

Operation

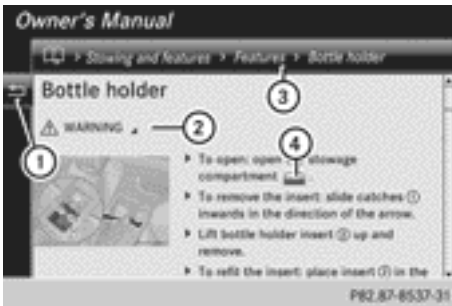

- ① Back symbol
- ② Hidden warning
- ③ Topic bar
- ④ Link to a continuing chapter

► **To navigate within a contents page:** turn or slide the COMAND controller to scroll the text up and down.

► **To navigate away from the contents page:** turn the COMAND controller to the left and select the button ①. Alternatively, press the button next to the COMAND controller. The previous page opens.

or

► Turn or slide the COMAND controller up to scroll to the very top of the contents page.

► Slide the COMAND controller up again to select topic bar ③.

► Turn or slide the COMAND controller to select the desired section or subsection. Confirm with .

The selected topic bar opens including all the subsections.

► **To select a link ④:** links are automatically highlighted when you scroll in a text. When you have selected a link, press the COMAND controller. The desired contents page opens.

► **To open up warning notes, environmental notes and fault information:** when scrolling through the text, the cursor jumps

automatically to the drop down warnings, environmental information and fault information. When you have selected the note, press the COMAND controller.

The warning note, environmental note or fault information opens up on the same page.

► **To navigate away from the Digital Owner's Manual:** press and hold the button next to the COMAND controller.

A window opens and you are asked if you would like to exit the browser.

► Confirm with "Yes".

The overview of COMAND Online functions opens.

► **Switching functions from the Digital Owner's Manual to COMAND Online using the COMAND function buttons:** press the or button in COMAND Online.

The desired menu opens.

► **To go back to the Digital Owner's Manual:** use the COMAND controller to select the symbol in the menu bar and press to confirm.

The last page called up in the Digital Owner's Manual is opened.

i The "Digital Owner's Manual" function is switched off while you are driving for reasons of safety.

Protection of the environment	36
Product information	36
Owner's Manual	37
Operating safety	37
Data stored in the vehicle	39
Copyright information	40

Protection of the environment

General notes

🌱 Environmental note

Daimler's declared policy is one of comprehensive environmental protection.

The objectives are for the natural resources which form the basis of our existence on this planet to be used sparingly and in a manner which takes the requirements of both nature and humanity into account.

You too can help to protect the environment by operating your vehicle in an environmentally-responsible manner.

Fuel consumption and the rate of engine, transmission, brake and tyre wear depend on the following factors:

- operating conditions of your vehicle
- your personal driving style

You can influence both factors. You should bear the following in mind:

Operating conditions:

- avoid short trips as these increase fuel consumption.
- make sure that the tyre pressures are always correct.
- do not carry any unnecessary weight.
- keep an eye on the vehicle's fuel consumption.
- remove roof racks once you no longer need them.
- a regularly serviced vehicle will contribute to environmental protection. You should therefore adhere to the service intervals.
- always have service work carried out at a qualified specialist workshop.

Personal driving style:

- do not depress the accelerator pedal when starting the engine.
- do not warm up the engine with the vehicle stationary.
- drive carefully and maintain a safe distance from the vehicle in front.

- avoid frequent, sudden acceleration.
- change gear in good time and use each gear only up to $\frac{2}{3}$ of its maximum engine speed.
- switch off the engine in stationary traffic.

Returning an end-of-life vehicle

EU countries only:

Mercedes-Benz will take back your old vehicle to dispose of it in an environmentally-responsible manner in accordance with the European Union (EU) End of Life Vehicles Directive.

There is a network of return points and disassembly plants available. In these plants you can return your vehicle free of charge. This makes a valuable contribution to the recycling process and the conservation of resources.

For further information on recycling old vehicles, recovery and the terms of the policy, visit the Mercedes-Benz homepage for your country.

Product information

Mercedes-Benz recommends that you use genuine Mercedes-Benz parts, conversion parts and accessories that have been approved for the type of vehicle.

Mercedes-Benz tests genuine parts and conversion parts and accessories that have been specifically approved for your vehicle for their reliability, safety and suitability. Despite ongoing market research, Mercedes-Benz is unable to assess other parts. Therefore, Mercedes-Benz accepts no responsibility for the use of such parts in Mercedes-Benz vehicles. This is also the case, even if they have been independently or officially approved. The use of non-approved parts could affect your vehicle's operating safety.

Mercedes-Benz therefore recommends that you use genuine Mercedes-Benz parts, con-

version parts and accessories that have been approved for the type of vehicle.

Genuine Mercedes-Benz parts, approved conversion parts and accessories are available from a Mercedes-Benz Service Centre. Here, you will receive advice about permissible technical modifications, and the parts will be professionally fitted.

Owner's Manual

General notes

Before you first drive off, read this Owner's Manual carefully and familiarise yourself with your vehicle.

For your own safety and a longer vehicle life, follow the instructions and warning notices in this manual. Disregarding them may lead to damage to the vehicle or personal injury.

Vehicle equipment

This Owner's Manual describes all models and all standard and optional equipment available for your vehicle at the time of publication of the Owner's Manual. Country-specific differences are possible. Note that your vehicle may not be fitted with all features described. This is also the case for systems and functions relevant to safety. Therefore, the equipment on your vehicle may differ from that in the descriptions and illustrations.

The original purchase contract documentation for your vehicle contains a list of all of the systems in your vehicle.

Should you have any questions concerning equipment and operation, please consult a Mercedes-Benz Service Centre.

The Owner's Manual and Service Booklet are important documents and should be kept in the vehicle.

Operating safety

Important safety notes

WARNING

All work on the vehicle and, in particular, work relevant to safety or on safety-related systems must be carried out at a qualified specialist workshop.

WARNING

Some safety systems only function when the engine is running. You should therefore never switch off the engine when driving. Otherwise, the safety systems of your vehicle may not function correctly and as a result will no longer protect you and other persons as intended. In addition, there is a risk that you may lose control of your vehicle and thus cause an accident.

WARNING

Work carried out incorrectly, or alterations made to the vehicle, e.g. re-routing of cables under coverings, could cause the safety systems of your vehicle to stop working properly. The safety systems would thus no longer protect you and other persons as intended. In addition, there is a risk that you may lose control of your vehicle and thus cause an accident.

All work and alterations to the vehicle, e.g. installations or modifications, should therefore be carried out at a qualified specialist workshop.

WARNING

If work on electronic equipment and its software is carried out incorrectly, this equipment could stop working. The electronic systems are networked via interfaces. Tampering with these electronic systems could cause malfunctions in systems which have not been modified. Malfunctions such as these can seriously jeopardise the vehicle's operating safety and therefore your own safety.

You should therefore have all work and modifications to electronic components carried out at a qualified specialist workshop.

Declarations of conformity

Wireless vehicle components

The following information applies to all components of the vehicle and the COMAND system which receive and/or transmit radio waves:

The components of this vehicle which receive and/or transmit radio waves are compliant with the basic requirements and other relevant provisions of Directive 1999/5/EC. You can obtain further information from any Mercedes-Benz Service Centre.

Electromagnetic compatibility

The electromagnetic compatibility of the vehicle components has been checked and certified according to the currently valid version of Directive 72/245/EEC or the equivalent ECE Regulation ECE-R 10.

Diagnostics connection

WARNING

If you connect equipment to a diagnostics connection, it can affect the operation of the vehicle systems. This could compromise the operating safety of your vehicle while driving. There is a risk of an accident.

Do not connect any equipment to a diagnostics connection.

WARNING

Loose equipment or cables hanging from a device which are connected to a diagnostic connection could impede pedal clearance. The equipment or cables could get caught between the pedals when driving and braking suddenly. This could impair the function of the pedals. There is a risk of accident.

Do not attach any equipment or cables in the driver's footwell.

-  If the engine is switched off and equipment on the diagnostics connection is used, the starter battery may discharge.

The diagnostics connection is only intended for the connection of diagnostic equipment at a qualified specialist workshop.

Connecting equipment to the diagnostics connection can lead to emissions monitoring information being reset, for example. This may lead to the vehicle failing to meet the requirements of the next emissions test during the main inspection.

Qualified specialist workshop

A qualified specialist workshop has the necessary special skills, tools and qualifications to correctly carry out any necessary work on your vehicle. This particularly applies to work relevant to safety.

Observe the notes in the Service Booklet.

Always have the following work carried out at a qualified specialist workshop:

- work relevant to safety
- service and maintenance work
- repair work
- modifications, installations and conversions
- work on electronic components

Mercedes-Benz recommends that you use a Mercedes-Benz Service Centre.

Vehicle registration

Mercedes-Benz may ask its Service Centres to carry out technical inspections on certain vehicles. The quality or safety of the vehicle is improved as a result of the inspection.

Mercedes-Benz can only inform you about vehicle checks if it has your registration data.

It is possible that your vehicle has not yet been registered in your name in the following cases:

- if your vehicle was not purchased at an authorised specialist dealer.
- if your vehicle has not yet been examined at a Mercedes-Benz Service Centre.

It is advisable to register your vehicle with a Mercedes-Benz Service Centre.

Inform Mercedes-Benz as soon as possible about any change in address or vehicle ownership.

Correct use

WARNING

Various warning stickers are affixed to your vehicle. Their purpose is to draw your attention, and the attention of others, to various dangers. Therefore, do not remove any warning stickers unless the sticker clearly states that you may do so.

If you remove the warning stickers, you or others could be injured by failing to recognise certain dangers.

Observe the following information when driving your vehicle:

- the safety notes in this manual
- the Technical Data section in this manual
- traffic rules and regulations
- laws and safety standards pertaining to motor vehicles

Implied warranty

! Follow the instructions in this manual about the proper operation of your vehicle as well as about possible vehicle damage. Damage to your vehicle that arises from culpable contraventions against these instructions are not covered either by Mercedes-Benz implied warranty or by the New or Used-Vehicle Warranty.

Data stored in the vehicle

A number of electronic components in your vehicle contain data memories.

These data memories temporarily or permanently store technical information about:

- the vehicle's operating state
- events
- faults

This technical information generally documents the condition of a component, a module, a system or an environment.

These are, for example:

- operating conditions of system components. This includes, e.g. fluid levels.
- status messages from the vehicle and from individual vehicle components. This includes, e.g. number of wheel revolutions/speed, deceleration, lateral acceleration.
- malfunctions and faults in important system components. This includes, e.g. lights, brakes.
- reactions of the vehicle in special driving situations. This includes, e.g. deployment of an airbag, intervention of stability control systems.
- environmental conditions. This includes, e.g. the outside temperature.

This data is exclusively technical in nature and is used to:

- assist in the detection and rectification of faults and defects
- optimise vehicle functions

The data cannot be used to trace the vehicle's movements over distances travelled.

When your vehicle is serviced, this technical information can be read out from the event and fault memory.

Services include:

- repairs
- service processes

- warranty claims
- quality assurance

The information is read out by authorised employees of the service network (including manufacturers) using special diagnostic devices. You can find more information there if necessary.

After a fault has been rectified, the information in the fault memory is deleted or consecutively overwritten.

In normal vehicle operation, situations may arise in which this technical data could become personal in nature in conjunction with other information and, if necessary, on consultation of an approval official.

Examples include:

- accident reports
- vehicle damage
- witness testimonies

Further additional features which are contractually agreed with the customer likewise allow specific vehicle data to be obtained from the vehicle. Such additional features include vehicle locating in an emergency, for example.

Copyright information

General notes

You can find information on licences for free and open-source software used in your vehicle and its electronic components on the following website:

<http://www.mercedes-benz.com/opensource>

Cockpit	42
Instrument cluster	44
Multifunction steering wheel	47
Centre console	48
Overhead control panel	51
Door control panel	52

Cockpit

At a glance

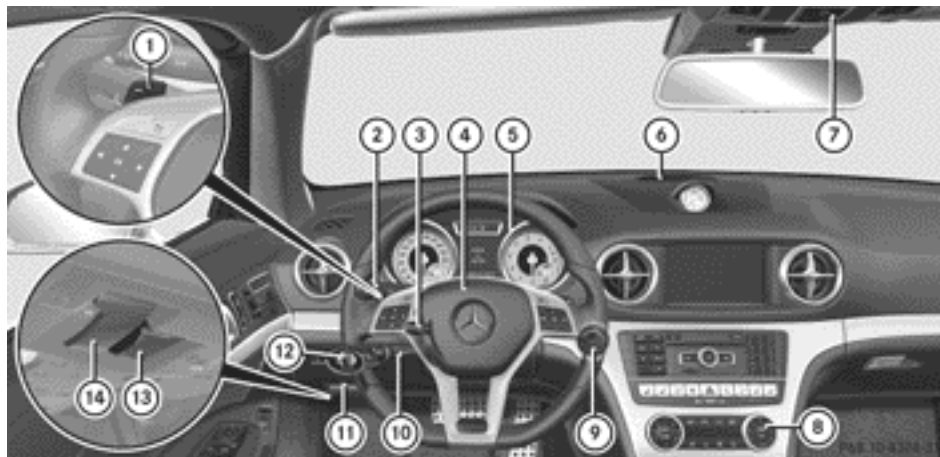

	Function	Page
①	Steering wheel gearshift paddles	166
②	Combination switch	129
③	To adjust the steering wheel electrically	118
④	Horn	
⑤	Instrument cluster	44
⑥	PARKTRONIC warning display	201
⑦	Overhead control panel	51

	Function	Page
⑧	Climate control systems	140
⑨	Ignition lock Start/Stop button	153 153
⑩	Cruise control lever	178
⑪	Electric parking brake	173
⑫	Light switch	126
⑬	To open the bonnet	531
⑭	Diagnostics connection	38

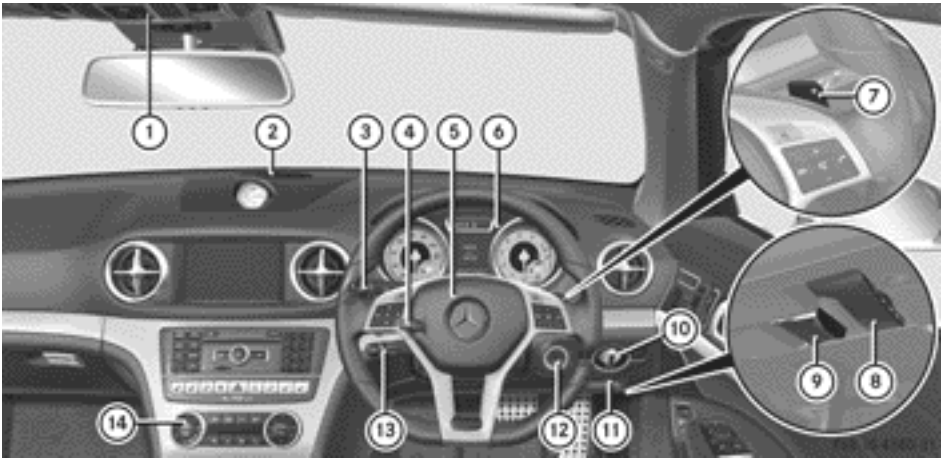

	Function	Page
①	Overhead control panel	51
②	PARKTRONIC warning display	201
③	Combination switch	129
④	To adjust the steering wheel electrically	118
⑤	Horn	
⑥	Instrument cluster	44
⑦	Steering wheel gearshift paddles	166

	Function	Page
⑧	Diagnostics connection	38
⑨	To open the bonnet	531
⑩	Light switch	126
⑪	Electric parking brake	173
⑫	Ignition lock	153
	Start/Stop button	153
⑬	Cruise control lever	178
⑭	Climate control systems	140

Instrument cluster

Displays and controls

At a glance

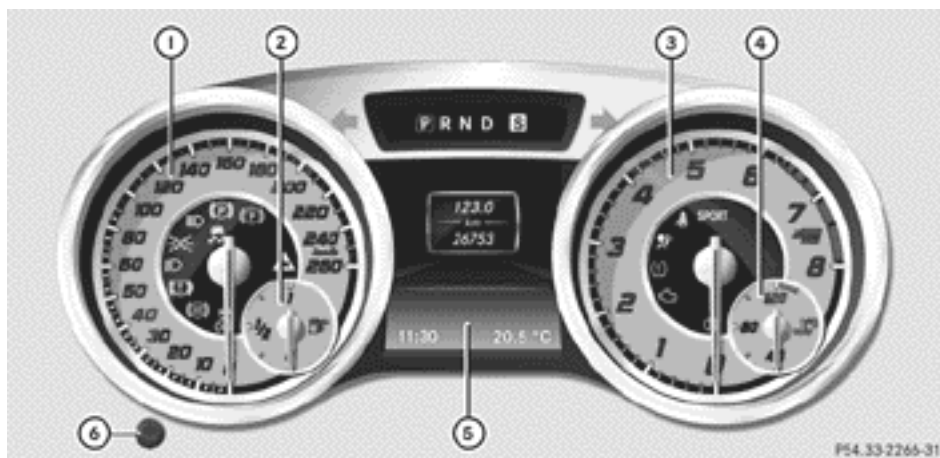
i Instrument cluster: kilometres

	Function	Page
①	Speedometer with segments	223
②	Fuel gauge	
③	Rev counter	222

	Function	Page
④	Coolant temperature	222
⑤	Multifunction display	224
⑥	Instrument cluster lighting	222



i Instrument cluster: miles

	Function	Page
①	Speedometer with segments	223
②	Fuel gauge	
③	Rev counter	222

	Function	Page
④	Coolant temperature	222
⑤	Multifunction display	224
⑥	Instrument cluster lighting	222

Warning and indicator lamps

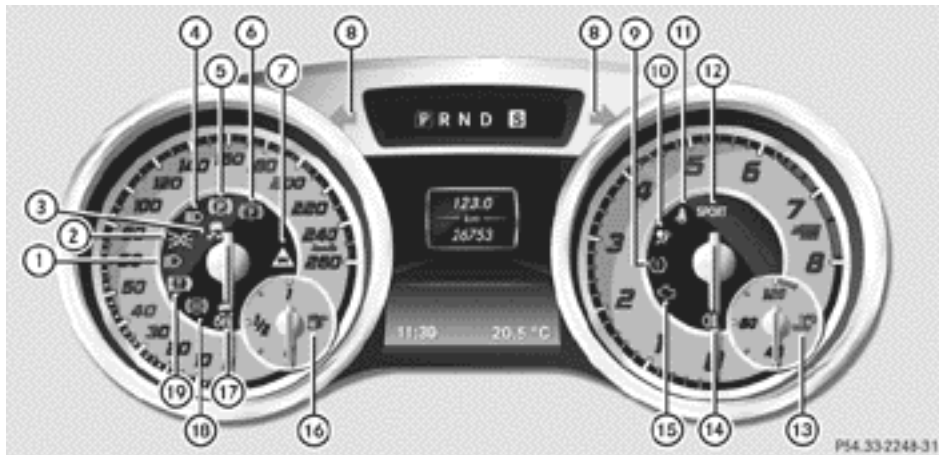













	Function	Page
①	Dipped-beam headlamps	127
②	Side lamps (AMG vehicles)	128
③	ESP®	273
④	Main-beam headlamps	129
⑤	Electric parking brake (red)	276
⑥	Electric parking brake (yellow)	276
⑦	Distance warning	279
⑧	Turn signals	129
⑨	Tyre pressure monitor	280

	Function	Page
⑩	SRS	276
⑪	Seat belt	269
⑫	SPORT handling mode (AMG vehicles)	274
⑬	Coolant	277
⑭	Rear foglamp	128
⑮	Engine diagnostics	276
⑯	Reserve fuel	276
⑰	ESP® OFF	273
⑱	ABS	271
⑲	Brakes	271

Multifunction steering wheel



	Function	Page
①	Multifunction display	224
②	COMAND display	284
③	 Switches on LINGUA-TRONIC; see the separate operating instructions	
④	 Rejects or ends a call Exits telephone book / redial memory  Makes or accepts a call Switches to the redial memory   Adjusts the volume  Mute	229

	Function	Page
⑤	  Selects a menu   Selects a submenu or scrolls through lists  Confirms your selection Hides display messages	223
⑥	 Back Switches off LINGUA-TRONIC; see the separate operating instructions	223

Centre console

Centre console, upper section

At a glance

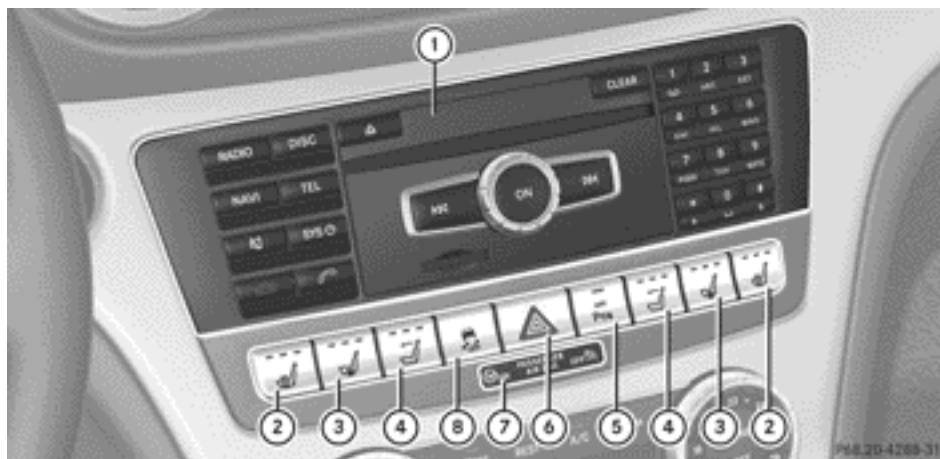



	Function	Page
①	COMAND Online	289
②	Seat heating	116
③	Seat ventilation	117
④	AIRSCARF	117
⑤	PARKTRONIC	201
⑥	Hazard warning lamps	130

	Function	Page
⑦	PASSENGER AIRBAG OFF indicator lamp	66
⑧	ESP® (except AMG vehicles)	75
	ECO start/stop function (AMG vehicles)	156

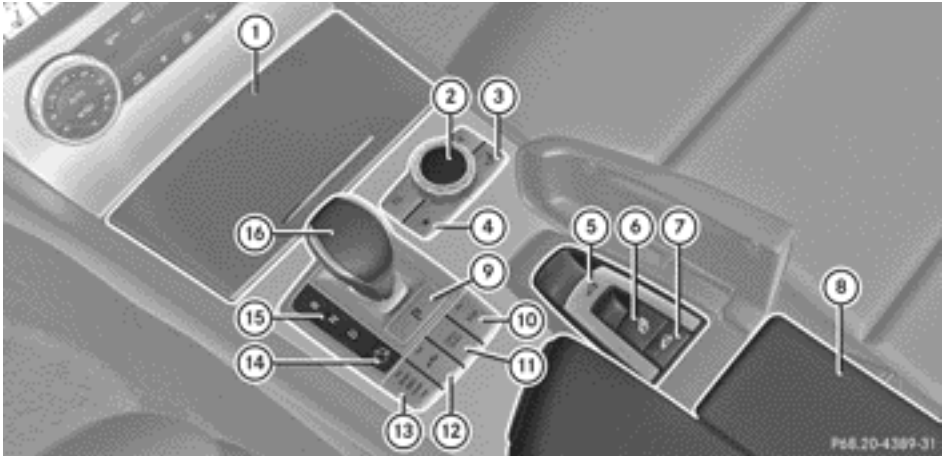
Centre console, lower section (except AMG vehicles)





	Function	Page		Function	Page
①	Stowage compartment	513	⑩	 start/stop button	156
	Cup holders	516	⑪	Shows the driving conditions menu in the COMAND display (vehicles with Active Body Control)	198
	Ashtray	517	⑫	 Sets the vehicle level	196
②	COMAND controller	291	⑬	Adjusts the suspension settings Sets the suspension tuning (vehicles with Active Body Control)	195
③	Seat adjustment	310			197
④	Favourites button	306	⑭	 Selects the drive program/program selector button	165
⑤	Roof switch	103	⑮	Transmission positions	164
⑥	Opens/closes the side windows	99	⑯	Selector lever	161
⑦	Extends/retracts the draught stop	107			
⑧	Stowage compartment	513			
	Cigarette lighter	518			
	Power socket	519			
⑨	Selects park position	161			

Centre console, lower section (AMG vehicles)

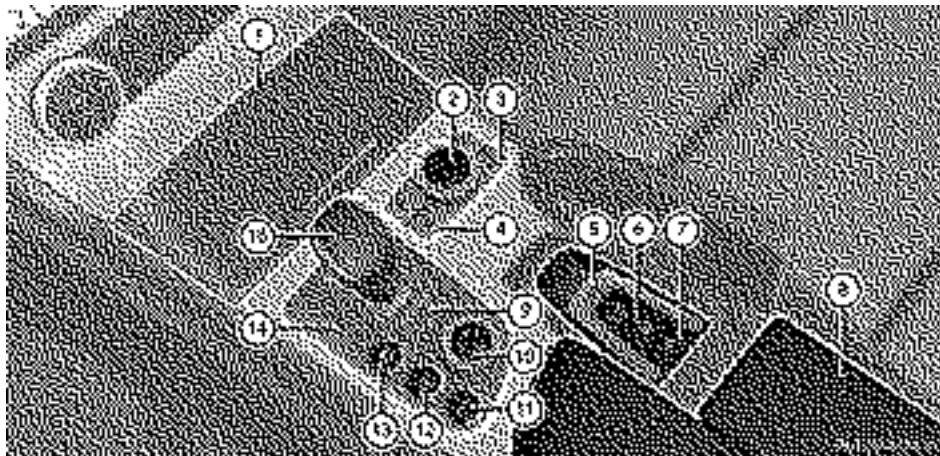
At a glance







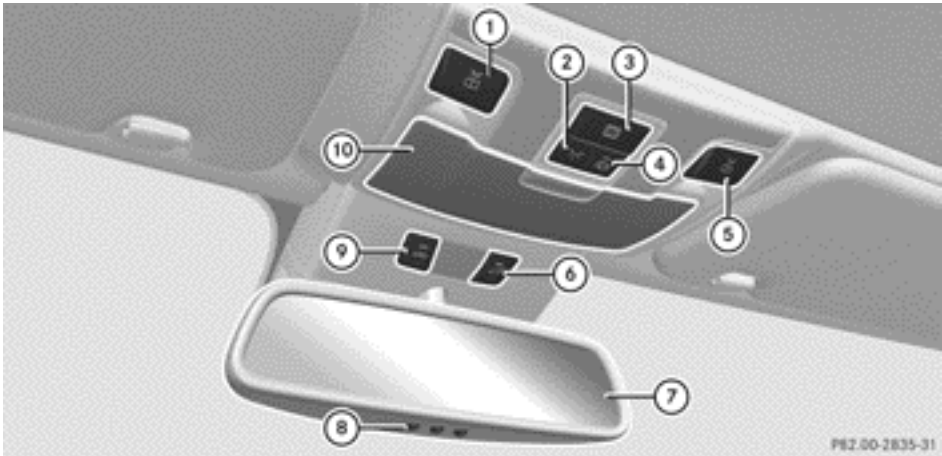

	Function	Page
①	Stowage compartment Cup holders Ashtray	513 516 517
②	COMAND controller	291
③	Seat adjustment	310
④	Favourites button	306
⑤	Roof switch	103
⑥	Opens/closes the side windows	99
⑦	Extends/retracts the draught stop	107
⑧	Stowage compartment Cigarette lighter Power socket	513 518 519

	Function	Page
⑨	Selects park position	161
⑩	Drive program selector	165
⑪	 button (drive program or calling up/storing suspension tuning)	166
⑫	 Sets the suspension tuning	200
⑬	 ESP®	75
⑭	Transmission positions	164
⑮	Selector lever	161







Overhead control panel

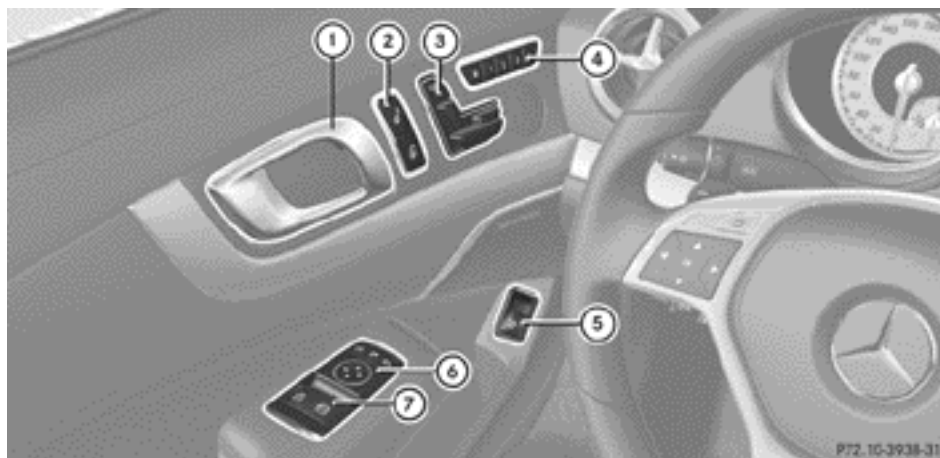







	Function	Page		Function	Page
①	 Switches the left-hand reading lamp on/off	133	⑥	 Deactivates tow-away protection	81
②	 Switches the interior lighting on/off	133	⑦	Rear-view mirror	119
③	 Operates MAGIC SKY CONTROL	108	⑧	Buttons for the garage door opener	523
④	 Switches the automatic interior lighting control on/off	133	⑨	 Deactivates the interior motion sensor	82
⑤	 Switches the right-hand reading lamp on/off	133	⑩	Spectacles compartment	513

Door control panel



	Function	Page
①	Opens the door	90
②	  Unlocks/locks the vehicle	91
③	Adjusts the seat	113
④	    Stores settings for the seat, exterior mirrors and steering wheel (memory function)	122
	 Adjusts the front-passenger seat from the driver's seat	114

	Function	Page
⑤	 Opens the boot lid	97
	 Opens/closes the boot lid	97
⑥	    Adjusts and folds the exterior mirrors in/out electrically	119
⑦	 Opens/closes the side windows	98

Useful information	54
Panic alarm	54
Occupant safety	54
Child restraint systems	64
Driving safety systems	72
Anti-theft systems	80

Useful information

- i** This Owner's Manual describes all models, series and optional equipment for your vehicle that were available at the time of going to press. National variations are possible. Note that your vehicle may not be equipped with all of the functions described. This is also the case for systems and functions relevant to safety.
- i** Read the information on qualified specialist workshops: (▷ page 38).

Panic alarm



- ▶ **To activate:** press the **PANIC** button ① for at least one second.
An alarm sounds and the exterior lighting flashes.
 - ▶ **To deactivate:** press the **PANIC** button ① again.
- or
- ▶ Insert the key into the ignition lock.
- or
- ▶ Press the KEYLESS-GO Start/Stop button.
The KEYLESS-GO key must be in the vehicle.
- i** The panic alarm function is only available in Mexico.

Occupant safety

Important safety notes

⚠ WARNING

If service work is not carried out correctly, the operating safety of your vehicle may be affected. This could cause you to lose control of your vehicle and cause an accident. Moreover, the safety systems may no longer be able to protect you or others as they are designed to do.

Always have service work carried out at a qualified specialist workshop.

⚠ WARNING

Modifications to or work performed incorrectly on the following parts can result in the restraint systems not functioning as intended:

- the restraint system, consisting of seat belts and their anchorage points, belt tensioners, belt force limiters and airbags
- the wiring
- networked electronic systems

Airbags and belt tensioners could fail to deploy or be triggered in an accident despite the deceleration force being sufficient to trigger the systems, or could be triggered unintentionally. For this reason, never make any modifications to the restraint systems.

Therefore, you must not tamper with electronic components or their software.

The seat belts, together with SRS (Supplemental Restraint System), are complementary, co-ordinated restraint systems (▷ page 55). They reduce the risk of injury in specific, pre-defined types of accident situations and thereby increase occupant safety. However, seat belts and airbags generally do not protect against objects penetrating the vehicle from the outside.

To ensure that the restraint systems can deliver their full potential protection, make sure that:

- the seat and head restraint are adjusted properly (▷ page 112)
- the seat belt has been fastened properly (▷ page 62)
- the airbags can inflate properly if they are deployed (▷ page 56)
- the steering wheel is adjusted properly (▷ page 118)
- the restraint systems have not been modified

An airbag increases the protection of vehicle occupants wearing a seat belt. However, airbags are only an additional restraint system which complements, but does not replace, the seat belt. All vehicle occupants must wear their seat belt correctly at all times, even if the vehicle is equipped with airbags. The airbags are not deployed in all types of accidents. For example, if the protective capacity of correctly fastened seat belts is not increased by deploying the airbags, the airbags will not deploy.

Airbag deployment only provides increased protection if the seat belt is worn correctly. First, the seat belt helps to keep the vehicle occupant in the best position in relation to the airbag. Second, in a head-on collision, for example, the seat belt prevents the vehicle occupant from being propelled towards the point of impact.

SRS (Supplemental Restraint System)

Introduction

SRS consists of:

- the  SRS warning lamp
- airbags
- the airbag control unit with crash sensors
- belt tensioners
- belt force limiters



SRS reduces the risk of occupants coming into contact with the vehicle's interior in the event of an accident. It can also reduce the forces to which occupants are subjected during an accident.

SRS warning lamp

WARNING

If SRS is malfunctioning, individual systems may be triggered unintentionally or might not be triggered in the event of an accident with a high rate of vehicle deceleration.

A malfunction has occurred if:

- the  SRS warning lamp does not light up when the ignition is switched on.
- the engine is running and the  SRS warning lamp does not go out after a few seconds.
- the engine is running and the  SRS warning lamp lights up again.

In this case, have SRS checked immediately at a qualified specialist workshop.

The  SRS warning lamp in the instrument cluster lights up when the ignition is switched on. It goes out no later than a few seconds after the engine is started.

SRS functions are checked regularly when the engine is running. Therefore, malfunctions can be detected in good time.

Triggering of belt tensioners, belt force limiters and airbags

During the first stage of a collision, the airbag control unit evaluates important physical data relating to vehicle deceleration or acceleration, such as:

- duration
- direction
- magnitude

Based on the evaluation of this pre-emptive data, in the event of a collision, the airbag control unit can trigger the belt tensioners in the first stage.

If there is an even higher rate of vehicle deceleration or acceleration in a longitudinal direction, the front airbags are also deployed.

Your vehicle has adaptive, two-stage front airbags. The airbag control unit evaluates vehicle deceleration or acceleration in the event of a collision. In the first deployment stage, the front airbag is filled with enough propellant gas to reduce the risk of injuries. The front airbag is fully deployed if a second deployment threshold is reached within a few milliseconds.

The belt tensioner and airbag triggering thresholds are variable and are adapted to the rate of deceleration or acceleration of the vehicle. This process is pre-emptive in nature. The triggering process must take place in good time at the start of the collision.

The rate of vehicle deceleration or acceleration and the direction of the force are essentially determined by:

- the distribution of forces during the collision
- the collision angle
- the deformation characteristics of the vehicle
- the characteristics of the object with which the vehicle has collided

Factors which can only be seen and measured after a collision has occurred do not play a decisive role in the deployment of an airbag, nor do they provide an indication of airbag deployment.

The vehicle may be deformed significantly, e.g. the bonnet or the wing, without an airbag being deployed. This is the case if only parts which are relatively easily deformed are affected and the rate of deceleration is not high. Conversely, airbags may be deployed even though the vehicle suffers only minor deformation. This is the case if, for example, very rigid vehicle parts such as longitudinal body members are hit, and sufficient deceleration occurs as a result.

i The belt tensioners can only be triggered if the seat belt tongues are correctly engaged in the seat belt buckles.

i Not all airbags are deployed in an accident. The different airbag systems work independently of each other.

How the airbag system works is determined by the severity of the collision detected, especially the vehicle deceleration or acceleration, and the apparent type of accident:

- head-on collision
- side impact
- rear impact
- overturn

Airbags

Important safety notes

WARNING

Airbag functionality can only be assured if the following parts are not covered and no badges or stickers are attached to them:

- padded steering wheel boss
- front-passenger airbag cover
- door trim
- outer side of seat bolsters

WARNING

Airbags provide additional protection; they are not, however, a substitute for seat belts.

Observe the following notes to reduce the risk of serious or even fatal injury caused by airbag deployment:

- all vehicle occupants – in particular, pregnant women – must wear their seat belt correctly at all times and lean back against the backrest, which should be positioned as close to the vertical as possible. The

head restraint must support the back of the head at about eye level.

- always secure children less than 1.50 m tall or under 12 years of age in suitable child restraint systems.
- all vehicle occupants must select a seat position that is as far away from the airbag as possible. The driver's seat position must allow the vehicle to be driven safely. The driver's chest should be as far away from the centre of the driver's airbag cover as possible.
- move the front-passenger seat as far back as possible. This is especially important if you have secured a child in a child restraint system on the front-passenger seat.
- vehicle occupants – in particular, children – must not lean their heads into the area of the window in which the sidebag/headbag is deployed.
- rearward-facing child restraint systems must not be fitted to the front-passenger seat unless the front-passenger front airbag has been disabled. The front-passenger front airbag is disabled if a child restraint system with transponders for automatic child seat recognition is fitted to the front-passenger seat. The  PASSENGER AIRBAG OFF indicator lamp must be continuously lit.

If you secure a forward-facing child restraint system to the front-passenger seat, you must move the front-passenger seat as far back as possible.

- make sure there are no heavy or sharp-edged objects in the pockets of clothing.
- do not lean forwards, e.g. over the cover of the driver's/front-passenger front airbag, particularly when the vehicle is in motion.
- do not put your feet on the dashboard.
- only hold the steering wheel on the outside. This allows the airbag to be fully deployed. You could be injured if the airbag is deployed and you are holding the inside of the steering wheel.

- do not lean on the doors from inside the vehicle.
- make sure that there are no people, animals or objects between the vehicle occupants and the area where the airbags are deployed.
- do not place any objects between the seat backrest and the door.
- do not hang any hard objects, for example, coat hangers, on the grab handles or coat hooks.
- do not attach accessories, e.g. cup holders, to the doors.

It is not possible to rule out a risk of injury being caused by an airbag, due to the high speed at which the airbag must be deployed.

WARNING

When an airbag deploys, a small amount of powder is released. The powder may cause short-term breathing difficulties to persons suffering from asthma or other pulmonary conditions.

In order to prevent potential breathing difficulties, you should leave the vehicle as soon as it is safe to do so. You can also open the window to allow fresh air to enter the vehicle interior. The powder does not constitute a health hazard and does not indicate that there is a fire in the vehicle.

WARNING

The airbag parts are hot after the airbag has been deployed. Do not touch them as you could burn yourself.

Have the airbags replaced at a qualified specialist workshop. Otherwise, occupants are not protected by the airbags in the event of another accident.

Airbag deployment slows down and restricts the movement of the vehicle occupant.

If the airbags are deployed, you will hear a bang and a small amount of powder may also be released. Only in rare cases will the bang affect your hearing. The powder that is

released generally does not constitute a health hazard. The  SRS warning lamp lights up.

The airbag installation locations are identified by the AIRBAG symbol.

Front airbags

! Do not place heavy objects on the front-passenger seat. The system may then detect that the seat is occupied and if there is an accident, the restraint systems on the front-passenger side could be deployed. Have restraint systems that have been triggered replaced.



Driver's airbag ① deploys in front of the steering wheel; front-passenger front airbag ② deploys in front of and above the glove compartment.



The front airbags increase protection against head and chest injuries.

They are deployed:

- at the start of an accident with a high rate of vehicle acceleration or deceleration in a longitudinal direction
- if the system determines that airbag deployment can offer additional protection to that provided by the seat belt
- depending on whether the seat belt is being used
- independently of other airbags in the vehicle

If the vehicle overturns, the front airbags are generally not deployed. The front airbags are

deployed if the system detects high vehicle deceleration in a longitudinal direction.

The front-passenger airbag is only activated if the system detects that the front-passenger seat is occupied. The  indicator lamp lights up for 60 seconds when the ignition is switched on. The  indicator lamp on the centre console is not lit (> page 66). This means that a child restraint system with transponders for automatic child seat recognition has not been fitted to the front-passenger seat or has been fitted incorrectly.

Sidebags

WARNING

If you wish to use seat covers, Mercedes-Benz recommends that, for safety reasons, you only use seat covers that have been approved for Mercedes-Benz vehicles.

The seat covers must have a special tear seam for sidebags. Otherwise, the sidebags cannot deploy correctly and would fail to provide the intended protection in the event of an accident. Appropriate seat covers can be obtained, for example, from a Mercedes-Benz Service Centre.



Example: sidebag on the driver's side

Sidebags ① deploy next to the outer side bolsters of the seat backrest.

When deployed, the sidebags offer additional protection for the thorax of the vehicle occupants on the side of the vehicle on which the impact occurs. However, they do not protect the:

- head
- neck
- arms

The sidebags are deployed:

- on the side on which an impact occurs
- at the start of an accident with a high rate of lateral vehicle deceleration or acceleration, e.g. in a side impact
- independently of the use of the seat belt
- independently of the front airbags
- independently of the belt tensioners

If the vehicle overturns, the sidebags are generally not deployed. Sidebags are deployed if the system detects high vehicle deceleration or acceleration in a lateral direction and determines that sidebag deployment can offer additional protection to that provided by the seat belt.

Headbags

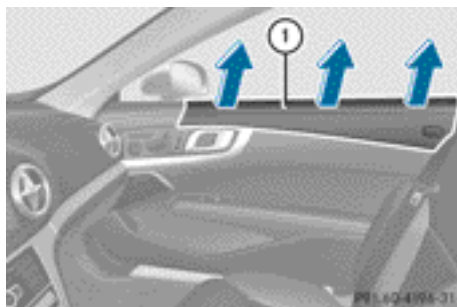

Example: headbag on the front-passenger side

Headbags ① deploy in the area of the side windows at the front. Headbags enhance the level of protection for the head, but not chest or arms, of the vehicle occupants on the side of the vehicle on which the impact occurs.

The headbags are deployed:

- at the start of an accident with a high rate of lateral vehicle deceleration or acceleration, e.g. in a side impact
- on the side on which an impact occurs
- on the driver's and the front passenger's side if the vehicle overturns and the system determines that windowbag deployment can offer additional protection to that provided by the seat belt
- independently of the use of the seat belt
- regardless of whether the front-passenger seat is occupied
- independently of the front airbags

Roll bar

⚠ DANGER

If the roll bar is malfunctioning, the  **Malfunction Consult workshop** message appears in the multifunction display. The roll bars will then possibly not be extended in the event of an accident. This could result in severe or even fatal injuries to you and other occupants. In this case, visit a qualified specialist workshop immediately and have the roll bar checked.

⚠ WARNING

If you place objects or clothing on the roll bar covers, these could impair roll bar extension. You and others could be injured by objects being thrown around when the roll bars are triggered.

Ensure that the area above the roll bar covers is kept clear. Stow objects or clothing in a secure place.

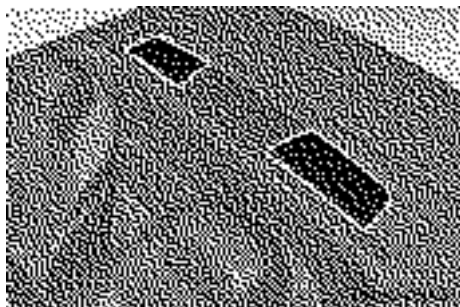

The roll bars are located in the rear area of the vehicle under the two outer rear compartment trim covers.

The roll bars are extended automatically if systems detect that the vehicle is in danger of overturning. The two rear compartment trim covers are opened and the roll bars are extended within fractions of a second.

Once the roll bars are extended, you can no longer lower them. An open roof can no longer be closed. In this case, visit the nearest qualified specialist workshop.

PRE-SAFE® (anticipatory occupant protection)

WARNING

When adjusting the seat, make sure that nobody can become trapped.

! Make sure that there are no objects in the footwell or behind the seats when moving the seat back. There is a risk that the seats and/or the objects could be damaged.

PRE-SAFE® takes pre-emptive measures to protect occupants in certain hazardous situations.

PRE-SAFE® intervenes:

- when BAS activates, e.g. in emergency braking situations
- when BAS PLUS intervenes powerfully on vehicles with DISTRONIC PLUS.

- when the radar sensor system detects an imminent danger of collision in certain situations on vehicles with DISTRONIC PLUS.
- in critical driving situations, e.g. when physical limits are exceeded and the vehicle understeers or oversteers severely

PRE-SAFE® takes the following measures depending on the hazardous situation detected:

- the seat belts are pre-tensioned.
- the front-passenger seat is adjusted if it is in an unfavourable position.
- vehicles with a multicontour seat or active multicontour seat: the air pressure in the side bolsters of the seat cushion and backrest is increased.
- if the vehicle skids, the side windows are closed almost completely.

If the hazardous situation passes without resulting in an accident, PRE-SAFE® slackens the belt pretensioning. All settings made by PRE-SAFE® can then be reversed.

If the seat belts are not released:

- ▶ Move the backrest or seat back slightly, but only when the vehicle is stationary. The belt pretensioning is reduced and the locking mechanism is released.

More information about seat belt adjustment, a convenience function integrated into PRE-SAFE (▷ page 63).

NECK-PRO head restraints

Important safety notes

WARNING

Only use head restraint covers which have been tested and approved by Mercedes-Benz for your vehicle model.

The use of non-approved head restraint covers may prevent NECK-PRO head restraints from triggering properly. Consequently, the NECK-PRO head restraints cannot provide the intended level of protection.

Consult a Mercedes-Benz Service Centre regarding availability.

The NECK-PRO head restraints reduce the likelihood of head and chest injuries. The NECK-PRO head restraints on the driver's and front-passenger seats are moved forwards and upwards in the event of a rear-end collision of a certain severity. This provides better head support.

If the NECK-PRO head restraints have been triggered in an accident, reset the NECK-PRO head restraints on the driver's and front-passenger seat (▷ page 61). Otherwise, the additional protection will not be available in the event of another rear-end collision. You can recognise when NECK-PRO head restraints have been triggered by the fact that they have moved forwards and can no longer be adjusted.

Mercedes-Benz recommends that you have the NECK-PRO head restraints checked at a qualified specialist workshop after a rear-end collision.

Resetting triggered NECK-PRO head restraints

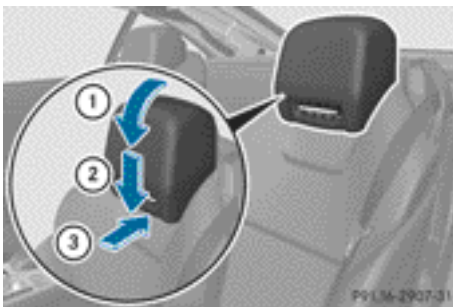

- ▶ Tilt the top of the NECK-PRO head restraint cushion forwards in the direction of arrow ①.
- ▶ Push the NECK-PRO head restraint cushion down in the direction of arrow ② as far as it will go.

- ▶ Firmly push the NECK-PRO head restraint cushion back in the direction of arrow ③ until the cushion engages.
- ▶ Repeat this procedure for the second NECK-PRO head restraint.
- ❗ Resetting the NECK-PRO head restraints requires a lot of strength. If you have difficulty resetting the NECK-PRO head restraints, have this work carried out at a qualified specialist workshop.

Seat belts

Important safety notes

WARNING

A seat belt which is not worn correctly, or which has not been engaged in the seat belt buckle correctly, cannot provide the intended level of protection. Under certain circumstances, this could cause severe or even fatal injuries in the event of an accident.

Make sure that all occupants – in particular, pregnant women – wear their seat belt correctly at all times.

- the seat belt must fit snugly on your body and must not be twisted. Therefore, avoid wearing bulky clothing, e.g. a winter coat. The shoulder belt section must be routed across the centre of your shoulder – on no account across your neck or under your arm – and pulled tight against your upper body. The lap belt must always pass across your lap as low down as possible, i.e. over your hip joints – not across your abdomen. If necessary, push down the belt strap slightly and then retighten it in the roll-up direction.
- seat belts must not be twisted within the belt loop on the seat.
- do not route the belt strap across sharp edges or fragile objects. This is especially the case if these are located on or in your clothing, e.g. spectacles, pens, keys, etc. The seat belt strap could be damaged and

tear in an accident, and you or other vehicle occupants could be injured.

- only one person should use each seat belt at any one time. Children must never travel sitting on the lap of other occupants. It would not be possible to restrain the child in the event of a sudden change in direction, braking or an accident. This could result in severe or even fatal injuries to the child and other occupants.
- persons less than 1.50 m tall cannot wear the seat belts correctly. For this reason, secure persons less than 1.50 m tall in specially designed, suitable restraint systems.
- children less than 1.50 m tall and under twelve years of age cannot wear the seat belts correctly. Therefore, they should always be secured in a suitable child restraint system on the front-passenger seat. You can find more information under "Children in the vehicle" in the "Safety" section of the Owner's Manual. Follow the manufacturer's installation instructions when fitting a child restraint system.
- Do not secure any objects with a seat belt if the seat belt is also being used by one of the vehicle's occupants.

WARNING

The seat belt does not offer the intended level of protection unless the backrest is almost vertical. Under certain circumstances, this could cause severe or even fatal injuries in the event of an accident.

Before starting a journey, make sure that the seat is properly adjusted and that the backrest is almost vertical.

WARNING

A dirty or damaged seat belt or one that has been modified or subjected to a load in an accident no longer offers the intended level of protection. Under certain circumstances, this could cause severe or even fatal injuries in the event of an accident.

For this reason, check regularly that the seat belts are not damaged or dirty.

Always have damaged seat belts or seat belts that have been subjected to a load in an accident replaced at a qualified specialist workshop.

For safety reasons, Mercedes-Benz recommends that you only use seat belts which have been approved by Mercedes-Benz for your vehicle.

Seat belts are the most effective means of restraining the movement of vehicle occupants in the event of an accident. This reduces the risk of vehicle occupants coming into contact with parts of the vehicle interior.

Fastening seat belts

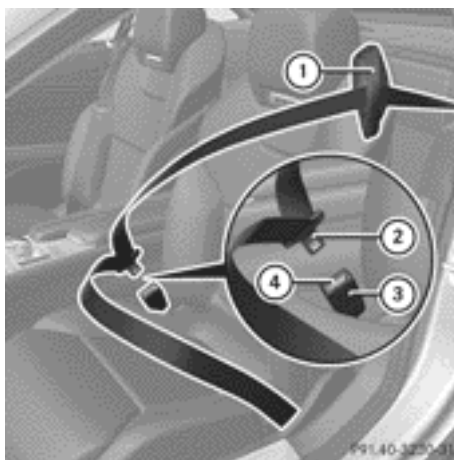

- ▶ Adjust the seat and move the backrest to an almost vertical position (▷ page 112).
- ▶ Pull the seat belt smoothly through seat belt guide ①.
- ▶ Without twisting it, guide the shoulder section of the seat belt across the middle of your shoulder and the lap section across your pelvis.
- ▶ Engage belt tongue ② in buckle ③.
Seat belt adjustment: if necessary, the driver's and front-passenger seat belts auto-

matically adjust to the upper body
(▷ page 63).

- ▶ If necessary, pull upwards on the shoulder section of the seat belt to tighten the belt across your body.

Information on releasing the seat belt with release button ④ (▷ page 63).

Seat belt adjustment

The seat-belt adjustment function adjusts the driver's and front-passenger seat belt to the upper body of the occupants.

The belt strap is tightened slightly when:

- you engage the belt tongue in the belt buckle and you then turn the key to position **2** in the ignition lock.
- the key is in position **2** in the ignition lock and you then engage the belt tongue in the buckle.

The seat-belt adjustment will apply a certain tightening force if any slack is detected between the occupant and the seat belt. Do not hold on to the seat belt tightly while it is adjusting. You can switch the belt adjustment on and off using the on-board computer (▷ page 237).

The seat belt adjustment is a convenience function integrated in PRE-SAFE® (preventative occupant protection). More information on PRE-SAFE® (▷ page 60).

Releasing the seat belts

- !** Make sure that the seat belt is fully rolled up. Otherwise, the seat belt or belt tongue will be trapped in the door or in the seat mechanism. This could damage the door, the door trim panel and the seat belt. Damaged seat belts can no longer fulfil their protective function and must be replaced. Visit a qualified specialist workshop.

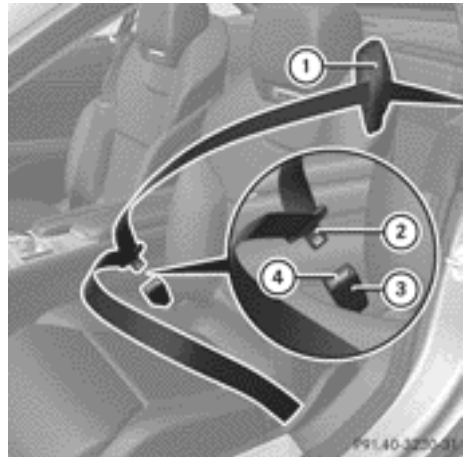



- ▶ Press release button ④ on belt buckle ③.
- ▶ Guide belt tongue ② back to seat belt guide ①.

Belt warning for the driver and front passenger

The  seat belt warning lamp in the instrument cluster is a reminder for all occupants to fasten their seat belts. It may light up continuously or flash. In addition, there may be a warning tone.

The  seat belt warning lamp goes out and the warning tone ceases when the driver and the front passenger have fastened their seat belt.

For certain countries only: regardless of whether the driver and the front passenger have fastened their seat belts, the  seat belt warning lamp lights up for six seconds after the engine is started. It then goes out if the driver and the front passenger have fastened their seat belts.

- i** For more information on the  seat belt warning lamp, see "Warning and indicator lamps in the instrument cluster, seat belt" (▷ page 269).

Belt tensioners, belt force limiters

WARNING

If the seat belt tensioners have been triggered, they provide no additional protection in the event of another accident. Therefore, have belt tensioners which have been triggered replaced at a qualified specialist workshop.

Comply with safety regulations when disposing of belt tensioners. Any Mercedes-Benz Service Centre can provide details of these regulations.

! If the front-passenger seat is not occupied, do not engage the seat belt tongue in the buckle on the front-passenger seat. Otherwise, the belt tensioner could be triggered in the event of an accident.

The belt tensioners tighten the seat belts in an accident, pulling them close against the body.

Belt tensioners do not correct incorrect seat positions or incorrectly fastened seat belts.

Belt tensioners do not pull vehicle occupants back towards the backrest.

If the seat belt is also fitted with a belt force limiter and this is triggered, the force exerted by the seat belt on the vehicle occupant is reduced.

The belt force limiters are synchronised with the front airbags. They take on a part of the deceleration force, resulting in the force exerted on the occupant being distributed over a greater area.

The belt tensioners can only be activated when:

- the ignition is switched on.
- the restraint systems are operational; see "SRS warning lamp" (> page 55).
- the belt tongue is engaged in the buckle on each of the three-point seat belts.

The belt tensioners are triggered depending on the type and severity of an accident:

- if, in the event of a head-on or rear-end collision the vehicle decelerates or accelerates rapidly in a longitudinal direction during the initial stages of the impact
- if, in the event of a side impact, on the side opposite the impact the vehicle decelerates or accelerates rapidly in a lateral direction
- in certain situations where the vehicle overturns and the system determines that it can provide additional protection

If the airbags are deployed, you will hear a bang, and a small amount of powder may also be released. Only in rare cases will the bang affect your hearing. The powder that is released generally does not constitute a health hazard. The  SRS warning lamp lights up.

Child restraint systems

Important safety notes

WARNING

To reduce the risk of serious or even fatal injury to the child in the event of a sudden change in direction, braking or an accident:

- children less than 1.50 m tall and under twelve years of age must always be secured in special child restraint systems on the front-passenger seat. This is necessary because the seat belts are not designed for children.
- you must move the front-passenger seat as far back as possible if you secure a forward-facing child restraint system without transponder for automatic child seat recognition to the front-passenger seat.
- children must never travel sitting on the lap of another occupant. Due to the forces which occur in the event of a sudden change of direction, heavy braking or an accident, it would not be possible to

restrain the child. The child could be thrown against parts of the vehicle interior and be seriously or even fatally injured.

WARNING

If the child restraint system is not properly fitted to the front-passenger seat, it cannot provide its protective function. The child cannot be restrained in the event of an accident, heavy braking or sudden changes of direction. The child could be seriously or even fatally injured. For this reason, when fitting a child restraint system, observe the manufacturer's installation instructions and the correct use of the child restraint system.

The entire base of the child restraint system must always rest on the seat cushion. Therefore, never place objects, e.g. a cushion, under the child restraint system.

Only use child restraint systems with the original cover designed for them. Only replace damaged covers with genuine Mercedes-Benz covers.

When possible, only use child restraint systems which have been approved for use in Mercedes-Benz vehicles.

WARNING

Do not leave children unsupervised in the vehicle, even if they are secured in a child restraint system. They could injure themselves on parts of the vehicle. They could also be seriously or even fatally injured by prolonged exposure to extreme heat or cold.

Do not expose the child restraint system to direct sunlight. Parts of the child restraint system could heat up and the child could burn herself/himself on them.

If a child opens a door, the child or other persons could be injured as a result. They could get out and injure themselves or be injured by a passing vehicle.

WARNING

Unsecured or incorrectly positioned loads increase the risk of injury for children and all other occupants in the event of:

- an accident
- sudden braking
- a sudden change of direction

Do not carry heavy or hard objects in the vehicle interior unless they are secured.

Information on the safe storage of loads (> page 512).

If a child is travelling in your vehicle, secure the child using a child restraint system which is recommended for Mercedes-Benz vehicles. The child restraint system must be appropriate to the age, weight and size of the child. Make sure that the child is secured for the trip.

Mercedes-Benz recommends that you use the listed child restraint systems (> page 71). You can obtain further information about the correct child restraint system from any Mercedes-Benz Service Centre.

-  It is advisable to use Mercedes-Benz care products to clean child restraint systems. You can obtain information about this at any Mercedes-Benz Service Centre.

Child restraint system on the front-passenger seat

WARNING



If the front-passenger front airbag is not disabled:

- a child secured in a child restraint system on the front-passenger seat could be seriously and even fatally injured by the front-passenger front airbag deploying. This is especially a risk if the child is in the imme-

diate vicinity of the front-passenger front airbag when it deploys.

- never secure a child on the front-passenger seat in a rearward-facing child restraint system.
- always move the front-passenger seat to the rearmost position if you secure a child in a forward-facing child restraint system on the front-passenger seat.

The front-passenger front airbag is not disabled:

- if no child restraint system with a transponder for automatic child seat recognition is fitted to the front-passenger seat. In order to make use of the automatic child seat recognition, a Mercedes-Benz approved child seat with a transponder is necessary.
- if the  PASSENGER AIRBAG ON indicator lamp lights up for 60 seconds after the ignition is switched on and the  PASSENGER AIRBAG OFF indicator lamp does not light up.

To make you aware of this danger, a corresponding warning sticker has been affixed on the dashboard and on both sides of the sun visor on the front-passenger side.

Information about recommended child restraint systems is available at any Mercedes-Benz Service Centre.



Warning notice on the front-passenger sun visor



Warning symbol for a rearward-facing child restraint system

Do not use a rearward-facing child restraint system on a seat that is protected by an airbag installed in front of it.

Automatic child seat recognition on the front-passenger seat

WARNING

If the  PASSENGER AIRBAG OFF indicator lamp does not light up when the child restraint system is fitted, the front-passenger airbag has not been disabled. If the front-passenger airbag deploys, the child could be seriously or even fatally injured.

Proceed as follows:

- do not use a rearward-facing child restraint system on the front-passenger seat.
- or
- only use a forward-facing child restraint system on the front-passenger seat and move the front-passenger seat to the rearmost position.
 - have the automatic child seat recognition checked at a qualified specialist workshop.





To ensure that the automatic child seat recognition on the front-passenger seat functions/communicates correctly, never place objects, e.g. a cushion, under the child restraint system. The entire base of the child restraint system must always rest on the seat cushion. An incorrectly fitted child restraint system cannot perform its intended protec-

tive function in the event of an accident, and could lead to injuries.



WARNING

Do not place electronic devices on the front-passenger seat, e.g.:

- laptops, when switched on
- mobile phones
- cards with transponders, e.g. ski passes or access cards



Signals from electronic equipment can cause interference in the automatic child seat recognition sensor system. This can lead to a system malfunction. Due to the interfering signal, the  indicator lamp, the  indicator lamp and the  warning lamp may all light up simultaneously. The  indicator lamp may light up without a child seat with a transponder for the automatic child seat recognition being fitted. The front-passenger airbag will not deploy during an accident.

When you switch on the ignition, it is also possible that:

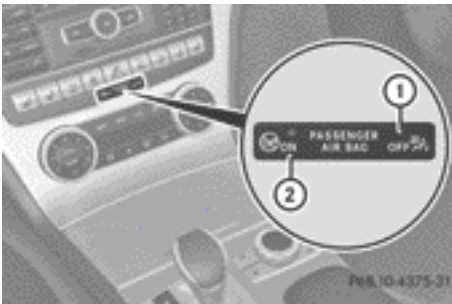
- the  SRS warning lamp lights up.
- the  indicator lamp does not light up briefly.
- the  indicator lamp does not light up, or lights up and does not go out after 60 seconds.



The automatic child seat recognition sensor system on the front-passenger seat detects whether a special Mercedes-Benz child seat

has been fitted there. The Mercedes-Benz child seat is equipped with transponders for automatic child seat recognition so that it can be detected by the sensor system. In this case, the  indicator lamp (2), lights up briefly when the ignition is switched on. The  indicator lamp (1) is lit continuously. The front-passenger front airbag is disabled.

i If the front-passenger front airbag is disabled by the automatic child seat recognition, the following remain enabled on the front-passenger side:

- the sidebag
- the headbag
- the belt tensioner

ISOFIX child seat securing system

WARNING

A child restraint system secured by the ISOFIX child seat securing system does not provide sufficient protection for children weighing more than 22 kg. For this reason, do not secure children weighing more than 22 kg in a child restraint system secured by the ISOFIX child seat securing system. If the child weighs more than 22 kg, secure the child restraint system using a three-point seat belt.

WARNING

If a child restraint system is not fitted properly, it cannot fulfil its protective function. The child cannot be restrained in the event of an accident, heavy braking or sudden changes of direction. The child could be seriously or even fatally injured. For this reason, when fitting a child restraint system, observe the manufacturer's installation instructions and the correct use of the child restraint system.

For safety reasons, only use child restraint systems with an ISOFIX child seat securing system which have been tested and approved for Mercedes-Benz vehicles.

An incorrectly fitted child restraint system could come loose and seriously or even fatally injure the child or other vehicle occupants. When fitting the child restraint system, always make sure that it is engaged correctly in the securing rings on both sides.

⚠ WARNING

Please note that if child restraint systems, or their retaining systems, are damaged or subjected to a load in an accident, they may not be able to provide their protective function. This could result in serious or even fatal injuries to the secured child in the event of an accident, heavy braking or a sudden change in direction.



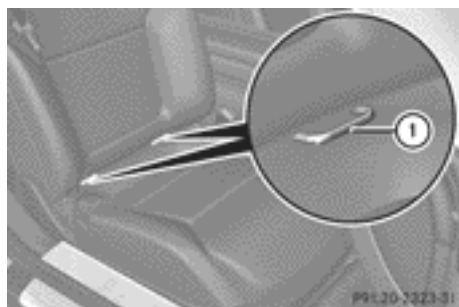

For this reason, have child restraint systems and their anchorages which have been damaged or subjected to a load in an accident checked immediately at a qualified specialist workshop.

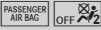

ISOFIX is a standardised securing system for specially designed child restraint systems. Securing rings ① for an ISOFIX child restraint system are fitted to the front-passenger seat.

- ▶ Install the ISOFIX child restraint system. Comply with the manufacturer's instructions when installing the ISOFIX child restraint system.

Problems with automatic child seat recognition

Problem	Possible causes/consequences and ► Solutions
<p>The  indicator lamp on the centre console is lit.</p>	<p>A special Mercedes-Benz child seat with a transponder for automatic child seat recognition has been fitted to the front-passenger seat. The front-passenger front airbag has therefore been disabled as desired.</p> <p>⚠ WARNING</p> <p>There is no child seat fitted to the front-passenger seat. Automatic child seat recognition is malfunctioning.</p> <p>When you switch on the ignition, it is also possible that:</p> <ul style="list-style-type: none"> • the  SRS warning lamp lights up. • the  indicator lamp does not light up briefly. • the  indicator lamp does not light up, or lights up and does not go out after 60 seconds. <p>There is a risk of injury.</p> <p>► Remove electronic equipment from the front-passenger seat, e.g.:</p> <ul style="list-style-type: none"> • laptop • mobile phone • cards with transponders, such as ski passes or access cards <p>If the  indicator lamp remains lit:</p> <p>► Visit a qualified specialist workshop.</p>

Suitable positioning of the child restraint systems

Installing a child restraint system on the front-passenger seat:

- Move the seat to its highest and rearmost position.
- Move the backrest to a vertical position.
- Move the seat cushion angle to the highest, most vertical position.
- Move the belt height adjustment to the lowest position.

Rearward-facing child restraint systems without a transponder for automatic child seat recognition may not be installed on the co-driver's seat.

Key to the letters used in the following table:

- X Seat which is unsuitable for children in this weight category.
- U Suitable for child restraint systems in the "Universal" category that are approved for use in this weight category.
- UF Suitable for forward-facing child restraint systems that belong to the "Universal" category and are approved for use in this weight category.
- L Suitable for child restraint systems as recommended; see the following table of "Recommended child restraint systems" (► page 71).

Weight categories	Front-passenger front air-bag is not disabled:	Front-passenger front air-bag is disabled.
Category 0: up to 10 kg	X	U, L
Category 0+: up to 13 kg	X	U, L
Category I: 9 to 18 kg	UF, L	U, L
Category II: 15 to 25 kg	UF, L	U, L
Category III: 22 to 36 kg	UF, L	U, L

Vehicles with automatic child seat recognition in the front-passenger seat: a "Universal" category child restraint system with a transponder for automatic child seat recognition must be fitted when the front-passenger front airbag is disabled. The



indicator lamp must light up. "Universal" category child restraint systems can be recognised by their orange approval label.



Example: approval label on the child restraint system

Suitability of the front-passenger seat for fitting an ISOFIX child restraint system:

Key to the letters used in the following table:

- X ISOFIX position that is not suitable for ISOFIX child restraint systems in this weight category and/or size category.
- IUF Suitable for forward-facing ISOFIX child restraint systems that belong to the "Universal" category which are approved for use in this weight category.
- IL Suitable for ISOFIX child restraint systems as recommended; see the following table of "Recommended child restraint systems" (> page 71).

Carry-cot weight category

Size category	Equipment	Front-passenger seat
F	ISO/L1	X
G	ISO/L2	X

Weight category 0: up to 10 kg, up to approximately 6 months

Size category	Equipment	Front-passenger seat
E	ISO/R1	X

Weight category 0+: up to 13 kg, up to approximately 15 months

Size category	Equipment	Front-passenger seat
E	ISO/R1	X
D	ISO/R2	X
C	ISO/R3	X

Weight category I: 9 to 18 kg, approximately 9 months to 4 years

Size category	Equipment	Front-passenger seat
D	ISO/R2	X
C	ISO/R3	X
B	ISO/F2	IUF
B1	ISO/F2X	IUF
A	ISO/F3	IUF

Recommended child restraint systems**Installing a child restraint system on the front-passenger seat:**

- ▶ Move the seat to its highest and rearmost position.
- ▶ Move the backrest to a vertical position.
- ▶ Move the seat cushion angle to the highest, most vertical position.
- ▶ Move the belt height adjustment to the lowest position.

Weight category 0: up to 10 kg, up to approximately 6 months

Manufacturer	Britax Römer
Type	BABY SAFE PLUS
Approval number (E1 ...)	03 301146 04 301146
Order number (A 000 ...)	970 10 00
Automatic child seat recognition	Yes

Weight category 0+: up to 13 kg, up to approximately 15 months

Manufacturer	Britax Römer
Type	BABY SAFE PLUS
Approval number (E1 ...)	03 301146 04 301146
Order number (A 000 ...)	970 10 00
Automatic child seat recognition	Yes

Weight category I: 9 to 18 kg, approximately 9 months to 4 years

Manufacturer	Britax Römer	Britax Römer
Type	DUO PLUS	DUO PLUS
Approval number (E1 ...)	03 301133 04 301133	03 301133 04 301133
Order number (A 000 ...)	970 11 00	970 16 00
Automatic child seat recognition	Yes	No

Weight category II/III: 15 to 36 kg, approximately 4 to 12 years

Manufacturer	Britax Römer	Britax Römer
Type	KID	KID
Approval number (E1 ...)	03 301148 04 301148	03 301148 04 301148

Order number (A 000 ...)	970 12 00	970 17 00
Automatic child seat recognition	Yes	No

Weight category II/III: 15 to 36 kg, approximately 4 to 12 years

Manufacturer	Britax Römer	Britax Römer
Type	KIDFIX	KIDFIX
Approval number (E1 ...)	04 301198	04 301198
Order number (A 000 ...)	970 18 00	970 19 00
Automatic child seat recognition	Yes	No

Suggested "Universal"/"Semi-Universal" category ISOFIX child restraint systems:

Category I: 9 to 18 kg

Size category	B1
Manufacturer	Britax Römer
Type	DUO PLUS
Approval number (E1 ...)	03 301133 04 301133
Order number	A000 970 11 00
Automatic child seat recognition	Yes

Driving safety systems

Driving safety systems overview

In this section, you will find information about the following driving safety systems:

- **ABS (Anti-lock Braking System)** (▷ page 73)
- **BAS (Brake Assist System)** (▷ page 73)
- **BAS PLUS (Brake Assist System Plus)** (▷ page 73)
- **Adaptive brake lamps** (▷ page 74)
- **ESP® (Electronic Stability Program)** (▷ page 75)
- **EBD (Electronic Brake force Distribution)** (▷ page 78)
- **ADAPTIVE BRAKE** (▷ page 78)
- **PRE-SAFE® Brake** (▷ page 78)
- **STEER CONTROL** (▷ page 80)

Important safety notes

If you fail to adapt your driving style or become distracted, the driving safety systems can neither reduce the risk of accident nor override the laws of physics. Driving safety systems are merely aids designed to assist driving. You are responsible for the distance to the vehicle in front, for vehicle speed and for braking in good time. Always adapt your driving style to suit the prevailing road and weather conditions and maintain a safe distance from the vehicle in front. Drive carefully.

- i** The driving safety systems described only work as effectively as possible when there is adequate contact between the tyres and the road surface. Please pay special attention to the notes on tyres, recommended minimum tyre tread depths, etc. (▷ page 562).

In wintry driving conditions, always use winter tyres (M+S tyres) and, if necessary, snow chains. Only in this way will the driv-

ing safety systems described in this section work as effectively as possible.

ABS (Anti-lock Braking System)

Important safety notes

- i** Observe the "Important safety notes" section (▷ page 72).

WARNING

If ABS is faulty, the wheels could lock when braking. The steerability and braking characteristics may be severely impaired. Additionally, further driving safety systems are deactivated. There is an increased danger of skidding and accidents.

Drive on carefully. Have ABS checked immediately at a qualified specialist workshop.

When ABS is malfunctioning, other systems, including driving safety systems, will also become inoperative. Observe the information on the ABS warning lamp (▷ page 271) and display messages which may be shown in the instrument cluster (▷ page 242).

ABS regulates brake pressure in such a way that the wheels do not lock when you brake. This allows you to continue steering the vehicle when braking.

ABS works from a speed of about 8 km/h upwards, regardless of road-surface conditions. ABS works on slippery surfaces, even when you only brake gently.

The yellow  ABS warning lamp in the instrument cluster lights up when the ignition is switched on. It goes out when the engine is running.

Brakes

- ▶ **If ABS intervenes:** continue to depress the brake pedal with force until the braking situation is over.
- ▶ **To make a full brake application:** depress the brake pedal with full force.

If ABS intervenes when braking, you will feel a pulsing in the brake pedal.

The pulsating brake pedal can be an indication of hazardous road conditions, and functions as a reminder to take extra care while driving.

BAS (Brake Assist System)

- i** Observe the "Important safety notes" section (▷ page 72).

WARNING

If BAS is malfunctioning, the braking distance in an emergency braking situation is increased. There is a risk of accident.

In an emergency braking situation, depress the brake pedal with full force. ABS prevents the wheels from locking.

BAS operates in emergency braking situations. If you depress the brake pedal quickly, BAS automatically boosts the braking force, thus shortening the stopping distance.

The brakes will function as usual once you release the brake pedal. BAS is deactivated.

BAS PLUS (Brake Assist System Plus)

- i** Observe the "Important safety notes" section (▷ page 72).

BAS PLUS is only available on vehicles with DISTRONIC PLUS.

For BAS PLUS to assist you, the radar sensor system must be:

- activated (▷ page 237)
- operational

- i** In some countries you must deactivate the radar sensor system (▷ page 237).

For further information on the radar sensor system (▷ page 595).

With the help of the radar sensor system, BAS PLUS can detect obstacles that are in the

path of your vehicle for an extended period of time.

BAS PLUS provides braking assistance in hazardous situations at speeds greater than 7 km/h. It uses radar sensor technology to assess the traffic situation.

At speeds of up to approximately 70 km/h, BAS PLUS can also detect stationary objects. Examples of stationary objects are stopped or parked vehicles.

To prevent a front-end collision, BAS PLUS calculates the brake force necessary if:

- you approach an obstacle, and
- BAS PLUS has detected a risk of collision

When driving at a speed under 30 km/h:

if you depress the brake pedal, BAS PLUS is activated. Braking will be carried out at the last possible moment.

When driving at a speed over 30 km/h: if you depress the brake pedal sharply, BAS PLUS automatically increases the brake pressure to a degree suited to the traffic situation. If BAS PLUS demands particularly high braking force, preventative passenger protection measures (PRE-SAFE®) are activated simultaneously.

- ▶ Keep the brake pedal depressed until the emergency braking situation is over. ABS prevents the wheels from locking.

BAS PLUS is deactivated and the brakes function as usual, if:

- you release the brake pedal
- there is no longer any danger of a collision
- no obstacle is detected in front of your vehicle

If the radar sensor system is malfunctioning, BAS PLUS will not be available. The brake system is still available with complete brake boosting effect and BAS.

WARNING

BAS PLUS cannot always clearly identify objects and complex traffic situations. BAS

PLUS cannot intervene in these cases. There is a risk of an accident.

Always pay careful attention to the traffic situation and be ready to brake.

In particular, the detection of obstacles can be impaired if there is:

- dirt on the sensors or anything else covering the sensors
- snow or heavy rain
- interference by other radar sources
- the possibility of strong radar reflections, for example, in multi-storey car parks
- a narrow vehicle travelling in front, e.g. a motorcycle
- a vehicle travelling in front on a different line

WARNING

BAS PLUS does not react:

- to people or animals
- to oncoming vehicles
- to crossing traffic
- when cornering

As a result, BAS PLUS may not intervene in all critical situations. There is a risk of an accident.

Always pay careful attention to the traffic situation and be ready to brake.

Following damage to the front end of the vehicle, have the configuration and operation of the radar sensors checked at a qualified specialist workshop. This also applies to collisions at slow speeds where there is no visible damage to the front of the vehicle.

Adaptive brake lamps

If you brake sharply from a speed of more than 50 km/h or if braking is assisted by BAS or BAS PLUS, the brake lamps flash rapidly. In this way, traffic travelling behind you is warned in an even more noticeable manner.

If you brake sharply from a speed of more than 70 km/h to a standstill, the hazard warning lamps are activated automatically. If the brakes are applied again, the brake lamps light up continuously. The hazard warning lamps switch off automatically if you travel faster than 10 km/h. You can also switch off the hazard warning lamps using the hazard warning button (▷ page 130).

ESP® (Electronic Stability Program)

General notes

i Observe the "Important safety notes" section (▷ page 72).

ESP® monitors driving stability and traction, i.e. power transmission between the tyres and the road surface.

If ESP® detects that the vehicle is deviating from the direction desired by the driver, one or more wheels are braked to stabilise the vehicle. The engine output is also modified to keep the vehicle on the desired course within physical limits. ESP® assists the driver when pulling away on wet or slippery roads. ESP® can also stabilise the vehicle during braking.

ETS (Electronic Traction System)

i Observe the "Important safety notes" section (▷ page 72).

ETS traction control is part of ESP®.

ETS brakes the drive wheels individually if they spin. This enables you to pull away and accelerate on slippery surfaces, for example if the road surface is slippery on one side.

ETS remains active when you deactivate ESP®.

Important safety notes

WARNING

If ESP® is malfunctioning, ESP® is unable to stabilise the vehicle. In addition, other driving



safety systems are switched off. This increases the risk of skidding and an accident.

Drive on carefully. Have ESP® checked at a qualified specialist workshop.

! When testing the electric parking brake on a braking dynamometer, switch off the ignition. Application of the brakes by ESP® may otherwise destroy the brake system.

When towing your vehicle with the rear axle raised, observe the notes on ESP® (▷ page 557).

ESP® is deactivated if the  warning lamp in the instrument cluster lights up continuously when the engine is running.

If the  warning lamp and the  warning lamp are lit continuously, ESP® is not available due to a malfunction.

Observe the information on warning lamps (▷ page 273) and display messages which may be shown in the instrument cluster (▷ page 242).

i Only use wheels with the recommended tyre sizes. Only then will ESP® function properly.

Characteristics of ESP®

General notes

ESP® is activated automatically when the engine is started.

If ESP® intervenes, the  ESP® warning lamp flashes in the instrument cluster.

If ESP® intervenes:

- ▶ Do not deactivate ESP® under any circumstances.
- ▶ When pulling away, only depress the accelerator pedal as far as is necessary.
- ▶ Adapt your driving style to suit the prevailing road and weather conditions.

Vehicles with the ECO start/stop function

The ECO start/stop function switches the engine off automatically if the vehicle stops moving. When pulling away again, the engine starts automatically. ESP® remains in its previously selected status. **Example:** if ESP® was deactivated before the engine was switched off, ESP® remains deactivated when the engine is switched on again.

Deactivating/activating ESP® (except AMG vehicles)

Important safety notes

i Observe the "Important safety notes" section (▷ page 72).

You can select between the following states of ESP®:

- ESP® is activated.
- ESP® is deactivated.

⚠ WARNING

If you deactivate ESP®, ESP® no longer stabilises the vehicle. There is an increased risk of skidding and an accident.

Only deactivate ESP® in the situations described in the following.

It may be best to deactivate ESP® in the following situations:

- when using snow chains
- in deep snow
- on sand or gravel

i Activate ESP® as soon as the situations described above no longer apply. ESP® will otherwise not be able to stabilise the vehicle if the vehicle starts to skid or a wheel starts to spin.

Deactivating/activating ESP®

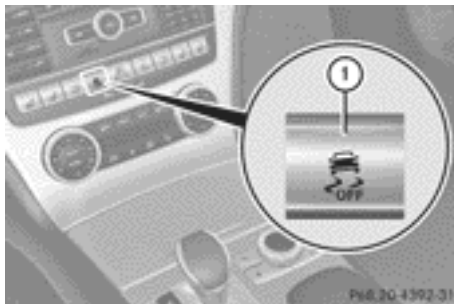

► **To switch off:** press button ①.

The  ESP® OFF warning lamp in the instrument cluster lights up.

► **To switch on:** press button ①.

The  ESP® OFF warning lamp in the instrument cluster goes out.

Characteristics when ESP® is deactivated

If ESP® is deactivated and one or more wheels start to spin, the  ESP® warning lamp in the instrument cluster flashes. In such situations, ESP® will not stabilise the vehicle.

If you deactivate ESP®:

- ESP® no longer improves driving stability.
- the engine's torque is no longer limited and the drive wheels are able to spin. The spinning of the wheels results in a cutting action, which provides better grip.
- ETS is still active.
- ESP® still provides support when you brake.

Deactivating/activating ESP® (AMG vehicles)

Important safety notes

i Observe the "Important safety notes" section (▷ page 72).

You can select between the following states of ESP®:

- ESP® is activated.
- SPORT handling mode is activated.
- ESP® is deactivated.

WARNING

When SPORT handling mode is activated, there is a greater risk of skidding and accidents.

Only activate SPORT handling mode in the situations described in the following.

WARNING

If you deactivate ESP®, ESP® no longer stabilises the vehicle. There is an increased risk of skidding and an accident.

Only deactivate ESP® in the situations described in the following.

In the following situations, it may be better to activate SPORT handling mode or deactivate ESP®:

- when using snow chains
- in deep snow
- on sand or gravel
- on designated roads when the vehicle's own oversteering and understeering characteristics are desired

Driving in SPORT handling mode or without ESP® requires an extremely qualified and experienced driver.

- i** Activate ESP® as soon as the situations described above no longer apply. ESP® will otherwise not be able to stabilise the vehicle if the vehicle starts to skid or a wheel starts to spin.

Deactivating/activating ESP®



► To activate SPORT handling mode:

briefly press button ①.

The **SPORT** handling mode warning lamp in the instrument cluster lights up. The **SPORT handling mode** message appears in the multifunction display.

► To deactivate SPORT handling mode:



briefly press button ①.

The **SPORT** handling mode warning lamp in the instrument cluster goes out.

► To deactivate ESP®: press button ② until the ESP® OFF warning lamp lights up in the instrument cluster.

The  OFF message appears in the multifunction display.

► To activate ESP®: briefly press button ①.

The  ESP® OFF warning lamp in the instrument cluster goes out. The  ESP® ON message appears in the multifunction display.

Characteristics of activated SPORT handling mode

If SPORT handling mode is activated and one or more wheels start to spin, the  ESP® warning lamp in the instrument cluster flashes. ESP® only stabilises the vehicle to a limited degree.

When SPORT handling mode is activated:

- ESP® only improves driving stability to a limited degree.
- the engine's torque is restricted to a limited degree and the drive wheels can spin. The spinning of the wheels results in a cutting action, which provides better grip.
- ETS is still active.
- ESP® still provides support when you brake.

Characteristics when ESP® is deactivated

If ESP® is deactivated and one or more wheels start to spin, the  ESP® warning lamp in the instrument cluster does not flash. In such situations, ESP® will not stabilise the vehicle. If you deactivate ESP®:

- ESP® no longer improves driving stability
- the engine's torque is no longer limited and the drive wheels are able to spin. The spinning of the wheels results in a cutting action, which provides better grip.
- ETS is still active
- PRE-SAFE® is no longer available; nor is it activated if you brake firmly and ESP® intervenes
- PRE-SAFE® Brake is no longer available; it is also not activated if you brake firmly and ESP® intervenes
- ESP® still provides support when you brake

EBD (electronic brake force distribution)

- Observe the "Important safety notes" section (▷ page 72).

WARNING

If EBD has malfunctioned, the rear wheels can still lock, e.g. under full braking. This increases the risk of skidding and an accident.

You should therefore adapt your driving style to the different handling characteristics. Have

the brake system checked at a qualified specialist workshop.

Observe information regarding indicator and warning lamps (▷ page 271) as well as display messages (▷ page 244).

EBD monitors and controls the brake pressure on the rear wheels to improve driving stability while braking.

ADAPTIVE BRAKE

ADAPTIVE BRAKE enhances braking safety and offers increased braking comfort. In addition to the braking function, ADAPTIVE BRAKE also has the HOLD function (▷ page 193) and hill start assist (▷ page 156).

PRE-SAFE® Brake

- Observe the "Important safety notes" section (▷ page 72).

PRE-SAFE® Brake is only available in vehicles with DISTRONIC PLUS.

For PRE-SAFE® Brake to assist you when driving, the radar sensor system must be:

- activated (▷ page 237)
- operational

- In some countries you must deactivate the radar sensor system (▷ page 237).

For further information on the radar sensor system (▷ page 595).

PRE-SAFE® Brake can help you to minimise the risk of a collision with a vehicle ahead or reduce the effects of such a collision. If PRE-SAFE® Brake has detected a risk of collision, you will be warned visually and acoustically as well as by automatic braking. PRE-SAFE® Brake cannot prevent a collision without your intervention.

This function will issue a warning if:

- at speeds of around 30 km/h or more, over several seconds, the distance maintained

to the vehicle travelling in front is insufficient.

The  distance warning lamp then lights up in the instrument cluster.

- at a speed of approximately 7 km/h or higher, you very quickly approach a vehicle in front.

An intermittent warning tone will then sound and the  distance warning lamp will light up in the instrument cluster.

- ▶ Brake immediately in order to increase the distance from the vehicle in front.

or

- ▶ Take evasive action provided it is safe to do so.

From a speed of approximately 7 km/h, if the driver and front passenger have fastened their seat belts, PRE-SAFE® Brake can brake the vehicle automatically at speeds up to approximately 200 km/h.

Due to the nature of the system, particularly complicated driving conditions may cause unnecessary warnings or the unnecessary intervention of PRE-SAFE® Brake.

You can prevent the intervention of the PRE-SAFE® Brake at any time by:

- depressing the accelerator pedal further
- activating kickdown
- releasing the brake pedal

The braking action of PRE-SAFE® Brake is ended automatically if:

- you manoeuvre to avoid the obstacle
- there is no longer any danger of a collision
- there is no longer an obstacle detected in front of your vehicle

With the help of the radar sensor system, PRE-SAFE® Brake can detect obstacles that are in front of your vehicle for an extended period of time.

At speeds of up to approximately 70 km/h, BAS PLUS can also detect stationary objects. Examples of stationary objects are stopped or parked vehicles.

If you approach an obstacle and PRE-SAFE® Brake detects a risk of a collision, the system will alert you both visually and acoustically. If you do not brake or take evasive action, the system will warn you by automatically braking the vehicle gently. If there is an increased risk of collision, preventive passenger protection measures (PRE-SAFE®) are activated (▷ page 60).

If, at speeds over 30 km/h, a risk of collision remains and you do not brake, take evasive action or significantly accelerate, automatic braking may be performed up to a level of automatic emergency braking. Automatic emergency braking is not performed until immediately prior to an accident that can no longer be avoided.

WARNING

PRE-SAFE® Brake will initially brake your vehicle by a partial application of the brakes if a danger of collision is detected. There may be a collision unless you also brake. Automatic emergency braking cannot prevent a collision. There is a risk of an accident.

Always apply the brakes yourself and try to take evasive action.

WARNING

PRE-SAFE® Brake cannot always clearly identify objects and complex traffic conditions.

In these cases, PRE-SAFE® Brake may:

- give an unnecessary warning and then brake the vehicle
- neither give a warning nor intervene

There is a risk of an accident.

Always pay particular attention to the traffic situation and be ready to brake, especially if PRE-SAFE® Brake warns you. Terminate the intervention in a non-critical driving situation.

In particular, the detection of obstacles can be impaired if there is:

- dirt on the sensors or anything else covering the sensors
- snow or heavy rain

- interference by other radar sources
- the possibility of strong radar reflections, for example, in multi-storey car parks
- a narrow vehicle travelling in front, e.g. a motorcycle
- a vehicle travelling in front on a different line

WARNING

PRE-SAFE® Brake does not react:



- to people or animals
- to oncoming vehicles
- to crossing traffic
- when cornering

As a result, PRE-SAFE® Brake may neither give warnings nor intervene in all critical situations. There is a risk of an accident.

Always pay careful attention to the traffic situation and be ready to brake.

In order to maintain the appropriate distance to the vehicle in front and thus prevent a collision, you must apply the brakes yourself.

► **To activate/deactivate:** activate or deactivate PRE-SAFE® Brake in the on-board computer (► page 231).

When PRE-SAFE® Brake is activated, the  symbol appears in multifunction display, as long as the HOLD function is deactivated (► page 193). On vehicles with Active Parking Assist, the  symbol is displayed when **P** is engaged or you are driving faster than 35 km/h.

Following damage to the front end of the vehicle, have the configuration and operation of the radar sensors checked at a qualified specialist workshop. This also applies to collisions at slow speeds where there is no visible damage to the front of the vehicle.

STEER CONTROL

STEER CONTROL helps you by transmitting a noticeable steering force to the steering

wheel in the direction required for vehicle stabilisation.

This steering support is provided in particular if:

- both right wheels or both left wheels are on a wet or slippery road surface when you brake.
- the vehicle starts to skid.

If ESP® is malfunctioning, you will not receive steering support from STEER CONTROL.

Power steering will, however, continue to function.

Anti-theft systems

Immobiliser

- **To activate with the key:** remove the key from the ignition lock.
- **To activate with KEYLESS-GO:** switch the ignition off and open the driver's door.
- **To deactivate:** switch on the ignition.

The immobiliser prevents your vehicle from being started without the correct key.

When leaving the vehicle, always take the SmartKey with you and lock the vehicle. The engine can be started by anyone with a valid key that is left inside the vehicle.

- i** The immobiliser is always deactivated when you start the engine.

ATA (Anti-Theft Alarm system)

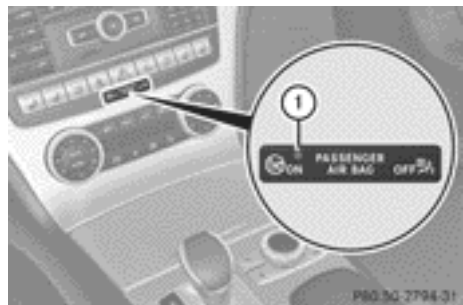



- ▶ **To prime:** lock the vehicle with the key or KEYLESS-GO.

Indicator lamp ① flashes. The alarm system is primed after approximately 15 seconds.

- ▶ **To switch off:** unlock the vehicle with the key or KEYLESS-GO.

A visual and audible alarm is triggered if the alarm system is primed and you open:

- a door
- the vehicle with the emergency key element
- the boot
- the bonnet
- the glove compartment
- the stowage space under the armrest
- a stowage compartment in the rear

- ▶ **To turn the alarm off with the key:** press the  or  button on the key. The alarm is switched off.

or

- ▶ Insert the key into the ignition lock. The alarm is switched off.

- ▶ **To stop the alarm using KEYLESS-GO:** grasp the outside door handle. The key must be outside the vehicle. The alarm is switched off.

or

- ▶ Press the Start/Stop button on the dashboard. The key must be inside the vehicle. The alarm is switched off.

The alarm is not switched off, even if you close the open door that has triggered it, for example.

Tow-away protection

Function

An audible and visual alarm is triggered if your vehicle's angle of inclination is altered while tow-away protection is primed. This can occur if the vehicle is jacked up on one side, for example.

Activating

- ▶ Make sure that:

- the doors are closed.
- the boot lid is closed.

Only then is the tow-away protection primed.

- ▶ Lock the vehicle with the key or KEYLESS-GO.

Tow-away protection is primed after approximately 30 seconds.

Deactivating

- ▶ **To switch off:** unlock the vehicle with the key or KEYLESS-GO.

Tow-away protection is switched off automatically.

Deactivating

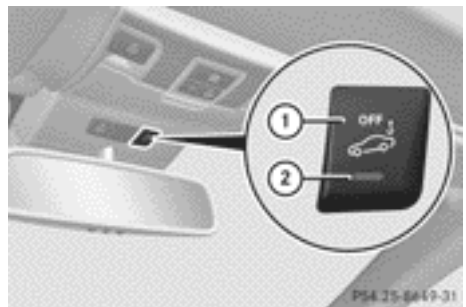

- ▶ Remove the key from the ignition lock.

- ▶ Press button ①.

Indicator lamp ② lights up briefly.

- ▶ Lock the vehicle with the key or KEYLESS-GO.

Tow-away protection is deactivated.

Tow-away protection remains deactivated until:

- the vehicle is unlocked again
- a door is opened and closed again
- the vehicle is locked again

To prevent a false alarm, deactivate the tow-away protection if you lock your vehicle and:

- it is being transported.
- it is being loaded onto a ferry or car transporter, for example.
- it is parked on a movable surface, e.g. in a split-level garage.

Interior motion sensor

Function

When the interior motion sensor is primed, a visual and audible alarm is triggered if movement is detected in the vehicle interior. This can occur if someone reaches into the vehicle interior, for example.

Activating

- ▶ Make sure that:
 - the side windows are closed.
 - the stowage compartment under the armrest is closed.
 This will prevent false alarms.
- ▶ Make sure that:
 - the roof is closed.
 - the doors are closed.
 - the boot lid is closed.
 Only then is the interior motion sensor primed.
- ▶ Lock the vehicle with the key or KEYLESS-GO.

The interior motion sensor is primed after approximately 30 seconds.

i Only for the Netherlands and Belgium: the interior motion sensor is primed even when the roof is open. However, the roof should be closed so as to prevent a false alarm.

Deactivating

- ▶ Unlock the vehicle with the key or KEYLESS-GO.

The interior motion sensor is switched off automatically.

Deactivating



- ▶ Remove the key from the ignition lock.
- ▶ Press button ①.

Indicator lamp ② flashes briefly.
- ▶ Lock the vehicle with the key or KEYLESS-GO.

The interior motion sensor is deactivated.

To prevent a false alarm, deactivate the interior motion sensor if you lock your vehicle and:

- people or animals remain in the vehicle.
- the side windows remain open.

The interior motion sensor remains deactivated until:

- the vehicle is unlocked again
- a door is opened and closed again
- the vehicle is locked again

i UK only: your vehicle is equipped with a double lock function. The doors cannot be opened from the inside if the vehicle has been locked with the key or with KEYLESS-GO. Deactivate the interior motion sensor before you lock the vehicle. The doors can then be opened from the inside after the vehicle has been locked from the outside. Observe the "Important safety notes" (▷ page 90).

Useful information	84
Key	84
Doors	90
Boot	93
Side windows	98
Roof	102

Useful information

i This Owner's Manual describes all models, series and optional equipment for your vehicle that were available at the time of going to press. National variations are possible. Note that your vehicle may not be equipped with all of the functions described. This is also the case for systems and functions relevant to safety.

i Read the information on qualified specialist workshops: (▷ page 38).

Key

Important safety notes

WARNING

Only for the United Kingdom: if the vehicle has been locked with the key or with KEY-LESS-GO, the double lock function is activated as standard. It is then not possible to open the doors from inside the vehicle.

Therefore, do not leave any people behind in the vehicle, particularly children, elderly people or people requiring special assistance. As a result, they may not be able to free themselves in the event of an emergency. They could be seriously or even fatally injured by prolonged exposure to extremely high or low temperatures, for example. In this case, rescuing people from outside the vehicle is difficult.

Deactivate the interior motion sensor before you lock the vehicle. The doors can then be opened from the inside after the vehicle has been locked from the outside.

WARNING

If children are left unsupervised in the vehicle, they could:

- open a door from inside the vehicle at any time, even if it has been locked
- start the vehicle using a key which has been left in the vehicle
- release the electric parking brake

They could thereby endanger themselves and others. Never leave children unsupervised in the vehicle. Always take the key with you when leaving the vehicle, even if you are only leaving it for a short time.

WARNING

If a key ring is too heavy or too large, the weight acting on the key could cause it to turn in the ignition lock or catch on the steering wheel. This could cause the engine to be switched off suddenly. You may lose control of the vehicle and cause an accident. Do not attach any heavy or large key rings to the key that is inserted in the ignition.

- Do not keep the key:
 - with electronic devices, e.g. a mobile phone or another key
 - with metallic objects, e.g. coins or metal film
 - inside metallic objects, e.g. a metal case

This can affect the key's functionality.

Keep the key away from strong magnetic fields. Otherwise, the remote control function could be affected.

Key functions

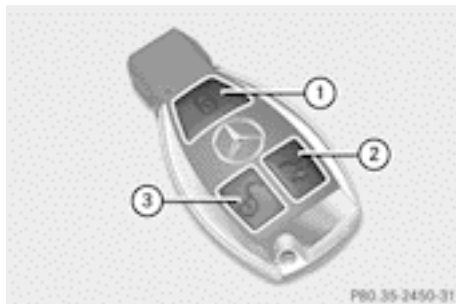

- ① To lock the vehicle
- ② To unlock the boot lid
- ③ To unlock the vehicle

► **To unlock centrally:** press the button.

If you do not open the vehicle within approximately 40 seconds of unlocking:

- the vehicle is locked again.
- the anti-theft system is primed again.

► **To lock centrally:** press the button.

The key centrally locks/unlocks:

- the doors
- the boot lid
- the glove compartment
- the stowage compartment under the arm-rest
- the stowage compartment in the rear compartment
- the fuel filler flap

When unlocking, the turn signals flash once. When locking, they flash three times.

You can also set an audible signal to confirm that the vehicle has been locked. The audible signal can be activated and deactivated using the on-board computer (▷ page 236).

When it is dark, the surround lighting also comes on if it is activated in the on-board computer (▷ page 235).

KEYLESS-GO

General notes

Bear in mind that the engine can be started by any of the vehicle occupants if there is a KEYLESS-GO key in the vehicle.

Locking and unlocking centrally

You can start, lock or unlock the vehicle using KEYLESS-GO. To do this, you only need carry the key with you. When you touch the surface of the sensors on the vehicle's outside door handles, KEYLESS-GO establishes a radio connection between the vehicle and the key. When the engine is started and whilst you are driving, KEYLESS-GO also checks whether a valid key is in the vehicle by periodically establishing radio contact.

You can combine the KEYLESS-GO functions with the functions of a conventional key. Unlock the vehicle by using KEYLESS-GO, for instance, and lock it using the button on the key.

When locking or unlocking with KEYLESS-GO, the distance between the key and the corresponding door handle must not be greater than 1 m.

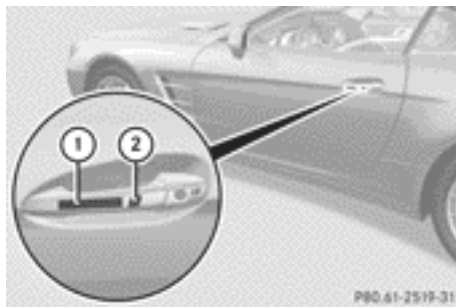

► **To unlock the vehicle:** touch the inner surface of the door handle.



► **To lock the vehicle:** touch sensor surface ①.



► **Convenience closing feature:** touch recessed sensor surface ② for an extended period (▷ page 100).

For further information on the convenience closing feature (▷ page 100).
If you pull the handle of the boot lid, only the boot of the vehicle is unlocked.



Changing the settings of the locking system

You can change the settings of the locking system. This means only the driver's door, the lockable stowage compartments in the vehicle interior and the fuel filler flap are unlocked when the vehicle is unlocked. This is useful if you frequently travel on your own.



► **To change the setting:** press and hold down the  and  buttons simultaneously for approximately six seconds until the battery check lamp flashes twice (▷ page 87).

- i** If the setting of the locking system is changed within the signal range of the vehicle, pressing the  or  button:
- locks or
 - unlocks the vehicle

The key now functions as follows:

- **To unlock the driver's door:** press the  button once.
- **To unlock centrally:** press the  button twice.
- **To lock centrally:** press the  button.

The KEYLESS-GO function is changed as follows:

- **To unlock the driver's door:** touch the inner surface of the door handle on the driver's door.
- **To unlock centrally:** touch the inner surface of the front-passenger door handle.
- **To lock centrally:** touch the outer sensor surface on one of the door handles.
- **To restore the factory settings:** press and hold down the  and  buttons simultaneously for approximately six sec-

onds until the battery check lamp flashes twice (▷ page 87).



Emergency key element

General notes

If the vehicle can no longer be locked or unlocked with the key, use the emergency key element.

If you use the emergency key element to unlock and open the driver's door or the boot lid, the anti-theft alarm system will be triggered (▷ page 80).

There are several ways to turn off the alarm:

- **To turn the alarm off with the key:** press the  or  button on the key.

or

- Insert the key into the ignition lock.

or

- **To deactivate the alarm with KEYLESS-GO:** press the Start/Stop button in the ignition lock. The key must be in the vehicle.

or

- Lock or unlock the vehicle using KEYLESS-GO. The key must be outside the vehicle.

If you unlock the vehicle using the emergency key element, the fuel filler flap will not be unlocked automatically.

- **To unlock the fuel filler flap:** insert the key into the ignition lock.

Removing the emergency key element

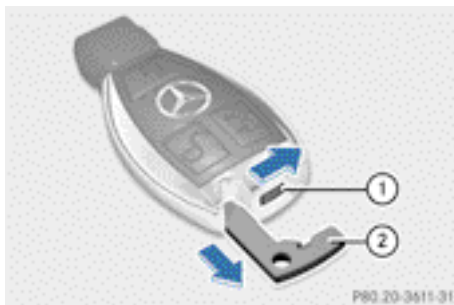

- ▶ Push release catch ① in the direction of the arrow and at the same time, remove emergency key element ② from the key.

Battery of the key

Important safety notes

WARNING

Batteries are toxic and contain caustic substances. For this reason, keep batteries out of the reach of children.

If a battery has been swallowed, visit a doctor immediately.

Environmental note



Batteries contain pollutants. It is illegal to dispose of them with the household rubbish. They must be collected separately and disposed of in an environmentally responsible recycling system.







Dispose of batteries in an environmentally responsible manner. Take discharged batteries to a qualified specialist workshop or to a collection point for used batteries.

Mercedes-Benz recommends that you have the batteries replaced at a qualified specialist workshop.

Checking the battery



- ▶ Press the  or  button. The battery is working properly if battery check lamp ① lights up briefly. The battery is discharged if battery check lamp ① does not light up briefly.
- ▶ Replace the battery (> page 87).
 - i** If the key battery is checked within the signal reception range of the vehicle, pressing the  or  button:
 - locks or
 - unlocks the vehicle
 - i** You can obtain a battery from any qualified specialist workshop.

Replacing the battery

You require a CR 2025 3 V cell battery.

- ▶ Take the emergency key element out of the key (> page 86).

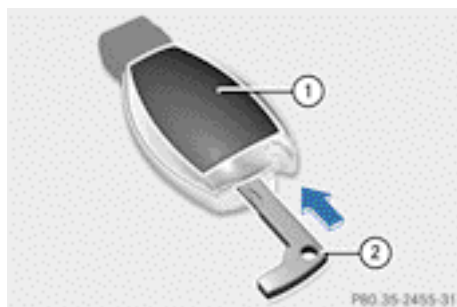







- ▶ Press emergency key element ② into the opening in the key in the direction of the arrow until battery compartment cover ①

opens. When doing so, do not hold battery compartment cover ① shut.

- ▶ Remove battery compartment cover ①.



- ▶ Repeatedly tap the key against your palm until battery ③ falls out.
- ▶ Insert the new battery with the positive terminal facing upwards. Use a lint-free cloth to do so.
- ▶ Make sure that the surface of the battery is free from lint, grease and all other forms of contamination.
- ▶ Insert the front tabs of battery compartment cover ① into the housing and then press to close it.
- ▶ Insert emergency key element ② into the key.
- ▶ Check the function of all key buttons on the vehicle.

Problems with the key	
Problem	Possible causes/consequences and ► Solutions
You cannot lock or unlock the vehicle using the key.	<p>The key battery is discharged or nearly discharged.</p> <ul style="list-style-type: none"> ► Try again to lock/unlock the vehicle using the remote control function of the key. Point the tip of the key at the driver's door handle from close range and press the  or  button. <p>If this does not work:</p> <ul style="list-style-type: none"> ► Check the key battery (▷ page 87) and replace it if necessary (▷ page 87). ► Lock (▷ page 92) or unlock (▷ page 93) the vehicle using the emergency key element.
	<p>The key is faulty.</p> <ul style="list-style-type: none"> ► Lock (▷ page 92) or unlock (▷ page 93) the vehicle using the emergency key element. ► Have the key checked at a qualified specialist workshop.
You can no longer lock or unlock the vehicle using KEYLESS-GO.	<p>There is interference from a powerful source of radio waves.</p> <ul style="list-style-type: none"> ► Lock/unlock the vehicle using the remote control function of the key. Point the tip of the key at the driver's door handle from close range and press the  or  button.
	<p>There is a fault with KEYLESS-GO.</p> <ul style="list-style-type: none"> ► Lock/unlock the vehicle using the remote control function of the key. Point the tip of the key at the driver's door handle from close range and press the  or  button. ► Have KEYLESS-GO checked at a qualified specialist workshop. <p>If this does not work:</p> <ul style="list-style-type: none"> ► Check the key battery (▷ page 87) and replace it if necessary (▷ page 87). ► Lock (▷ page 92) or unlock (▷ page 93) the vehicle using the emergency key element.
You have lost a key.	<ul style="list-style-type: none"> ► Have the key deactivated at a qualified specialist workshop. ► Report the loss immediately to the vehicle insurers. ► If necessary, have the locks changed as well.
You have lost the emergency key element.	<ul style="list-style-type: none"> ► Report the loss immediately to the vehicle insurers. ► If necessary, have the locks changed as well.

Problem	Possible causes/consequences and ► Solutions
The engine cannot be started using the key.	<p>The on-board voltage is too low.</p> <ul style="list-style-type: none"> ► Switch off non-essential consumers, e.g. seat heating or interior lighting, and try to start the engine again. <p>If this does not work:</p> <ul style="list-style-type: none"> ► Check the starter battery and charge it if necessary (▷ page 552). <p>or</p> <ul style="list-style-type: none"> ► Jump-start the vehicle (▷ page 553). <p>or</p> <ul style="list-style-type: none"> ► Consult a qualified specialist workshop.
The engine cannot be started using KEYLESS-GO. The key is in the vehicle.	<p>A door is open. Therefore, the key cannot be detected as easily.</p> <ul style="list-style-type: none"> ► Close the door and try to start the vehicle again.
	<p>There is interference from a powerful source of radio waves.</p> <ul style="list-style-type: none"> ► Start your vehicle with the key in the ignition lock.

Doors

Important safety notes

WARNING

Only for the United Kingdom: if the vehicle has been locked with the key or with KEYLESS-GO, the double lock function is activated as standard. It is then not possible to open the doors from inside the vehicle.

Therefore, do not leave any people behind in the vehicle, particularly children, elderly people or people requiring special assistance. As a result, they may not be able to free themselves in the event of an emergency. They could be seriously or even fatally injured by prolonged exposure to extremely high or low temperatures, for example. In this case, rescuing people from outside the vehicle is difficult.

Deactivate the interior motion sensor before you lock the vehicle. The doors can then be opened from the inside after the vehicle has been locked from the outside.

WARNING

If children are left unsupervised in the vehicle, they could:

- open a door from inside the vehicle at any time, even if it has been locked
- start the vehicle using a key which has been left in the vehicle
- release the electric parking brake

They could thereby endanger themselves and others. Never leave children unsupervised in the vehicle. Always take the key with you when leaving the vehicle, even if you are only leaving it for a short time.

Unlocking and opening the doors from the inside

-  The side windows will not open/close if the battery is discharged or if the side windows have iced up. It will then not be possible to close the door. Do not attempt to force the door to close. You could otherwise damage the door or the side window.

For all countries except the United Kingdom: you can open a door from inside the vehicle even if it has been locked.

If the vehicle has previously been locked with the key or with KEYLESS-GO, opening a door from the inside will trigger the anti-theft alarm system. Switch off the alarm (▷ page 80).

United Kingdom only: if the vehicle has been locked with the key or with KEYLESS-GO, the double lock function is activated as standard. It is then not possible to open the doors from inside the vehicle. Deactivate the interior motion sensor (▷ page 82) before you lock the vehicle. The doors can then be opened from the inside after the vehicle has been locked from the outside. The anti-theft alarm system is triggered if the door is opened from the inside. Switch off the alarm (▷ page 80).

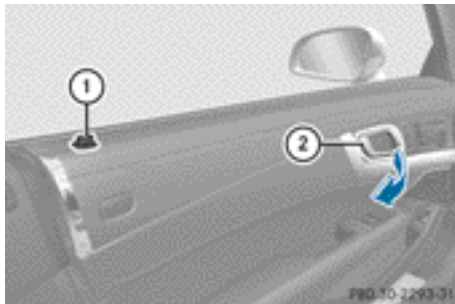

▶ Pull door handle ②.

If the door is locked, locking knob ① pops up. The door is unlocked and can be opened.

i When a door is opened, the side window on that side opens slightly. When the door is closed, the side window closes again.

Centrally locking and unlocking the vehicle from the inside

You can centrally lock or unlock the vehicle from the inside. For example, you can unlock the front-passenger door from the inside or lock the vehicle before you pull away.

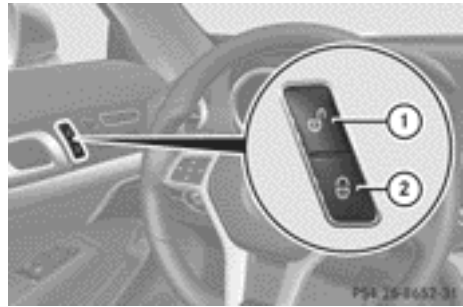

▶ **To unlock:** press button ①.

▶ **To lock:** press button ②.

If the front-passenger door is closed, the vehicle locks.

The central locking/unlocking button does not lock or unlock the fuel filler flap or the stowage compartments, such as the glove compartment.

You cannot unlock the vehicle centrally from the inside if the vehicle has been locked with the key or KEYLESS-GO.

For all countries except the United Kingdom: you can open a door from inside the vehicle even if it has been locked.

United Kingdom only: if the vehicle has been locked with the key or with KEYLESS-GO, the double lock function is activated as standard. It is then not possible to open the doors from inside the vehicle. Deactivate the interior motion sensor (▷ page 82) before you lock the vehicle. The doors can then be opened from the inside after the vehicle has been locked from the outside.

If the vehicle has been locked using the locking button for the central locking, or has been locked automatically, and a door is opened from the inside:

- the vehicle will be fully unlocked if it had previously been fully unlocked
- only the door which has been opened from the inside is unlocked if only the driver's door had been previously unlocked

Automatic locking feature

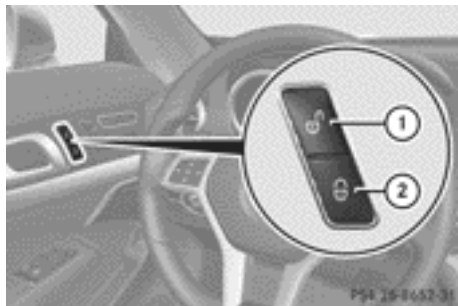

① To deactivate

② To activate

► **To deactivate:** press and hold button ① for about five seconds until a tone sounds.

► **To activate:** press and hold button ② for about five seconds until a tone sounds.

i If you press one of the two buttons and do not hear a tone, the relevant setting has already been selected.

The vehicle is locked automatically when the ignition is switched on and the wheels are turning.

You could therefore be locked out if:

- the vehicle is being pushed.
- the vehicle is being towed.
- the vehicle is being tested on a dynamometer.

You can also switch the automatic locking function on and off using the on-board computer (▷ page 236).

Power closing feature

⚠ WARNING

Make sure that nobody can become trapped as you close the doors and boot lid.

If there is a danger of being trapped, pull the door handle on the inside or outside or pull the boot lid handle.

Do not activate the power closing feature by tampering with the lock mechanism. You could otherwise injure yourself.

⚠ WARNING

Make sure that the doors and boot lid are always fully closed. Otherwise, a door or the boot lid could open during the journey and endanger yourself or others.

The power closing feature pulls the doors and boot lid into their locks automatically even if they are only partly closed.

► **Power closing feature (doors):** push the door past the first detent position of the lock.

The power closing feature will pull the door fully closed.

► **Power closing feature (boot lid):** lightly push the boot lid closed.

The power closing feature will pull the boot lid fully closed.

Unlocking the driver's door (emergency key element)

If the vehicle can no longer be unlocked with the key, use the emergency key element.

If you use the emergency key element to unlock and open the driver's door, the anti-theft alarm system will be triggered (▷ page 80).

► Take the emergency key element out of the key (▷ page 86).

► Insert the emergency key element into the lock of the driver's door as far as it will go.

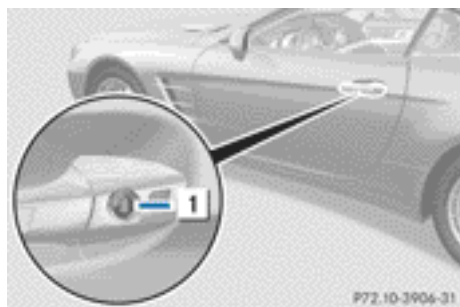
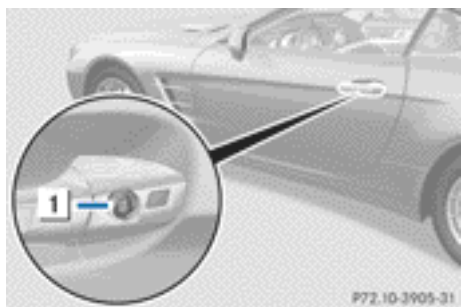

- ▶ Turn the emergency key element anti-clockwise to position **1**.
The door is unlocked.
- i** On right-hand-drive vehicles, turn the emergency key element clockwise.
- ▶ Turn the emergency key element back and remove it.
- ▶ Insert the emergency key element into the key.

Locking the vehicle (emergency key element)

If the vehicle can no longer be locked with the key, use the emergency key element.

- ▶ Open the driver's door.
- ▶ Close the front-passenger door and the boot lid.
- ▶ Press the locking button (▷ page 91).
- ▶ Check whether the locking knob on the front-passenger door is still visible. If necessary, press the locking knob down by hand (▷ page 90).
- ▶ Close the driver's door.
- ▶ Take the emergency key element out of the key (▷ page 86).
- ▶ Insert the emergency key element into the lock of the driver's door as far as it will go.

1 Locking

- ▶ Turn the emergency key element clockwise as far as it will go to position **1**.
- i** On right-hand-drive vehicles, turn the emergency key element anti-clockwise.
- ▶ Turn the emergency key element back and remove it.
- ▶ Make sure that the doors and the boot lid are locked.
- ▶ Insert the emergency key element into the key.
- i** If you lock the vehicle as described above, the fuel filler flap is not locked. The anti-theft alarm system is not primed.

Boot

Important safety notes

⚠ WARNING

Exhaust fumes could enter the vehicle interior if the engine is running and the boot lid is open. This could poison you. Therefore, you should make sure that the boot lid is always closed when the engine is running.

- !** The boot lid swings upwards when opened. Therefore, make sure that there is sufficient clearance above the boot lid.
- !** Only close the boot once the roof is lowered completely. Otherwise, you could damage the roof.

- i** Opening dimensions of the boot lid (▷ page 593).
- i** To make it easier to load your luggage, you can raise the stowed roof with the loading aid after you have opened the boot lid. In addition, you can release the boot separator. The boot separator must be closed again after loading. Otherwise, the roof cannot be lowered.

You can unlock the boot lid when the vehicle is stationary and the roof is fully opened or closed.

Do not leave the key in the boot. You could otherwise lock yourself out.

The boot lid can be:

- opened and closed from outside
- opened automatically from outside (vehicles without boot lid remote closing feature)
- opened and closed automatically from outside (vehicles with boot lid remote closing feature)
- opened and closed from outside (vehicles with KEYLESS-GO and HANDS-FREE ACCESS)
- opened and closed automatically from inside (vehicles with boot lid remote closing feature)
- locked separately
- unlocked with the emergency key element

Opening/closing from the outside

Opening

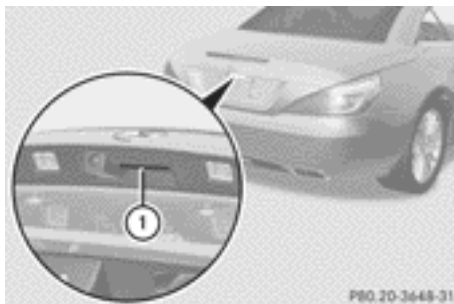

- ▶ Press the  button on the key.
- ▶ Pull handle ①.
- ▶ Raise the boot lid.

- i** With the roof open, you can use the loading aid (▷ page 514) to raise the folded-up roof in the boot, enabling you to load and unload more easily. For this purpose, you can also open the boot separator.

Do not forget to close the boot separator again afterwards. Otherwise, the roof can no longer be closed.

Closing

WARNING

Make sure that nobody can become trapped when closing the boot lid.

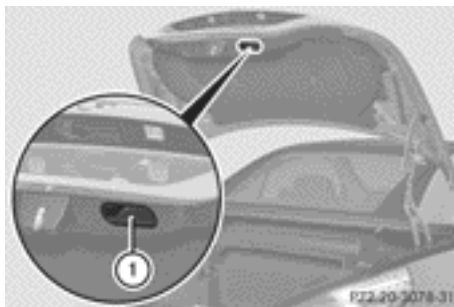

- ▶ Pull the boot lid down using recess ①.
- ▶ Lock the vehicle if necessary with the  button on the key or with KEYLESS-GO.
- i** If a KEYLESS-GO key is detected in the boot, the boot lid cannot be locked. It then opens again.

Opening/closing automatically from the outside

Important safety notes

WARNING

Monitor the boot lid opening and closing procedures to make sure that nobody can become trapped. To stop the opening or closing procedure, press the closing button on the boot lid again or pull the handle on the outside of the boot lid.

- !** The boot lid swings upwards when opened. Therefore, make sure that there is sufficient clearance above the boot lid.
- i** Opening dimensions of the boot lid (▷ page 593).

Opening

You can open the boot lid automatically using the key or the handle in the boot lid.

- ▶ Press and hold the  button on the key until the boot lid opens.
- or
- ▶ If the boot is unlocked, pull the boot lid handle and release it again immediately.

Closing

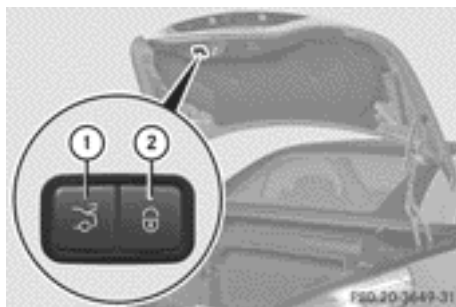

- ① Closing button
- ② Locking button

- ▶ **To close:** press closing button ① in the boot lid.

Vehicles with boot lid remote closing feature and KEYLESS-GO: you can simultaneously close and lock the boot lid.

- ▶ Press locking button ② in the boot lid. If a KEYLESS-GO key is detected outside the vehicle, the boot lid closes and locks.
- i** If a KEYLESS-GO key is detected in the boot, the boot lid cannot be locked. It then opens again.

HANDS-FREE ACCESS

Important safety notes

WARNING

Body parts could become trapped when automatically opening or closing the boot lid with the HANDS-FREE ACCESS function. This poses a risk of injury. Keep hands and other body parts away from the boot opening. Always keep an eye on the area around the rear of the vehicle when opening or closing the boot lid. Make sure that nobody can become trapped.

To stop the opening or closing procedure:

- kick with your leg in the sensor detection range under the bumper
- pull the handle on the outside of the boot lid
- press the closing button in the boot lid, or
- press the  button on the key

If the boot lid closing procedure has been stopped:

- kick with your leg again under the bumper and the boot lid will open.

If the boot lid opening procedure has been stopped:

- kick with your leg again under the bumper and the boot lid will close.

WARNING

By making a kicking movement under the bumper with your leg, you could burn yourself on the hot exhaust system. Make sure that the kicking movement is only carried out in the detection range of the sensors.

! If a KEYLESS-GO key is within the detection range of the KEYLESS-GO aerials, the following situations could lead to the unintentional opening of the boot:

- using a car wash
- using a high-pressure cleaner

Make sure that the key is at least 2 m away from the vehicle.

Important notes on the use of HANDS-FREE ACCESS:

- With KEYLESS-GO and HANDS-FREE ACCESS, you can open or close the boot lid or stop the procedure without using your hands. This is useful if you have your hands full. To do this, simply make a kicking movement under the bumper with your leg.
- Remove the key from the ignition lock.
- With KEYLESS-GO, make sure the ignition is switched off (> page 153).

- Carry your KEYLESS-GO key on your person. The key must be located near to the rear area of the vehicle.
- When making the kicking movement, make sure that you are standing firmly on the ground. You could otherwise lose your balance, e.g. on ice.
- Stand at least 30 cm away from the rear area while doing so.
- Do not come into contact with the bumper while making the kicking movement. Otherwise, the sensors may not function correctly and you risk dirtying your clothes.
- HANDS-FREE ACCESS does not work with a prosthetic leg.

Operation

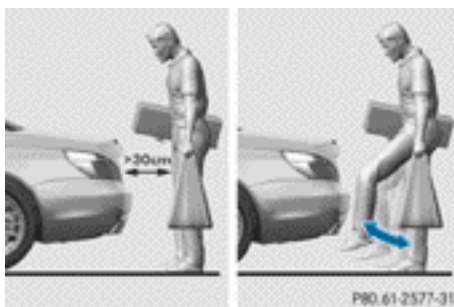

► **To open/close:** kick into sensor detection range ① under the bumper with your leg.

You do not need to come into contact with the bumper when doing this. You will hear a warning tone while the boot lid is opening or closing.

► **If the boot lid does not open after several attempts:** wait at least ten seconds then kick under the bumper once again.

i If you hold your leg under the bumper for too long, the boot lid will not open or close. Repeat the leg movement more quickly if this occurs.

Opening/closing automatically from the inside

Important safety notes

⚠ WARNING

Monitor the boot lid closing procedure to make sure that nobody can become trapped. Release the boot lid remote operating button to stop the closing procedure.

! The boot lid swings upwards when opened. Therefore, make sure that there is sufficient clearance above the boot lid.

i The opening dimensions of the boot lid can be found in the "Vehicle data" section (▷ page 593).

Opening and closing



► **To open:** pull remote operating switch for boot lid ① until the boot lid opens.

► **To close:** press remote operating switch for boot lid ① until the boot lid is closed.

You can open and close the boot lid from the driver's seat when the vehicle is stationary and unlocked.

Locking the boot separately

The separate boot locking function is only available in certain countries.

You can lock the boot separately. If you then unlock the vehicle centrally, the boot remains locked and cannot be opened.

► Close the boot lid.

► Take the emergency key element out of the key (▷ page 86).

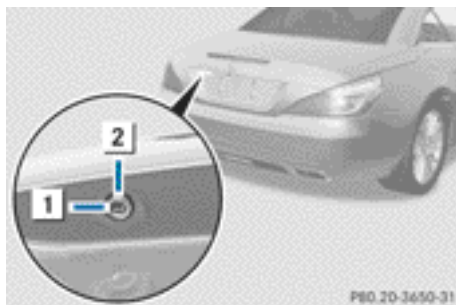

① Basic position

② Locking

► Insert the emergency key element into the boot lid lock as far as the stop.

► Turn the emergency key element clockwise from position ① to position ②.

► Pull out the emergency key element.

► Insert the emergency key element into the key.

Unlocking the boot (emergency key element)

! The boot lid swings upwards when opened. Therefore, make sure that there is sufficient clearance above the boot lid.

If the boot cannot be unlocked with the key or KEYLESS-GO, use the emergency key element.

If you use the emergency key element to unlock and open the boot lid, the anti-theft alarm system will be triggered (▷ page 80).

- ▶ Take the emergency key element out of the key (▷ page 86).
- ▶ Insert the emergency key element into the boot lid lock as far as the stop.

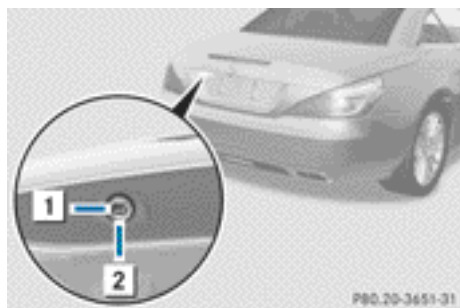

1 Basic position

2 To unlock

- ▶ Turn the emergency key element anti-clockwise from position **1** as far as it will go to position **2**.
- ▶ Pull the boot lid handle. The boot is unlocked.
- ▶ Turn the emergency key element back to position **1** and remove it.
- ▶ Insert the emergency key element into the key.

Side windows

Important safety notes

⚠ WARNING

Make sure that nobody can become trapped between the side window and the door frame when a side window is opened. Do not touch or lean against the side window during the opening procedure. You could become trapped between the side window and the door frame as the side window moves down. If there is a risk of becoming trapped, release the switch or pull the switch upwards to close the side window again.

⚠ WARNING

Make sure that nobody can become trapped as you close a side window. If there is a risk of becoming trapped, release the switch or press it again to open the side window again.

⚠ WARNING

Children may injure themselves if they open or close the side windows.

Never leave children unsupervised in the vehicle. Always take the key with you when leaving the vehicle, even if you are only leaving it for a short time.

⚠ WARNING

Do not leave children unsupervised in the vehicle, even if they are secured in a child restraint system. The children could:

- be seriously or even fatally injured on parts of the vehicle
- be seriously or even fatally injured by prolonged exposure to extremely high or extremely low temperatures

If children open a door, they could:

- seriously or even fatally injure other people
- get out of the vehicle and injure themselves, or be seriously or even fatally injured by a passing vehicle

Opening and closing the side windows

Opening and closing the side windows in the front

The switches for the side windows are located on the driver's door. There is also a switch for the front-passenger side window on the front-passenger door.

The switches on the driver's door take precedence.

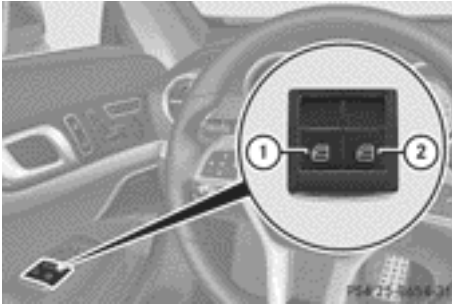

- ① Left
- ② Right

- ▶ Turn the key to position **1** or **2** in the ignition lock.
 - ▶ **To open:** press the corresponding switch.
 - ▶ **To close:** pull the corresponding switch.
 - ▶ **Automatic operation:** press or pull the corresponding switch beyond the point of resistance. The side window opens or closes fully.
 - ▶ **To interrupt automatic operation:** press or pull the corresponding switch again.
- i** You can continue to operate the side windows after you switch off the engine. This function remains active for five minutes or until the driver's or front-passenger door is opened.

Opening/closing the rear side windows

- ▶ **To open:** open the front side window on the corresponding side (▷ page 99).
- ▶ Press the corresponding switch again. The corresponding rear side window opens fully.
- ▶ **To stop the rear side windows:** briefly pull the corresponding switch up.
- ▶ **To close:** close the front side window on the corresponding side (▷ page 99).
- ▶ Pull the respective switch and hold it. The corresponding rear side window will continue to close until you release the switch.

Opening and closing all side windows

Using the switch on the centre console

You can use the button on the centre console to close all side windows simultaneously.

- ▶ Open the cover on the lower centre console. The switch for all side windows is under the cover.



- ▶ **To open all side windows:** press switch ① to the point of resistance.
- ▶ **To open all side windows fully:** press switch ① beyond the point of resistance. All side windows open simultaneously.

i If, after opening the windows, you close one side window using the button in the door control panel:

- the front side window closes first and
- then the corresponding rear side window closes

► **To close all side windows:** pull switch ①.

All side windows begin the closing procedure simultaneously. The rear side windows close after the front side windows.



► Make sure that all the side windows are fully closed.

Using the key



WARNING

Make sure that nobody can become trapped as you close the side windows.

Proceed as follows if there is a risk of entrapment:

- Release the  button.
- Press and hold the  button until the side windows open again.

You can use the key to open or close all side windows simultaneously.

- Close the roof (► page 103).
- Open the boot separator (► page 104).
- **Vehicles without KEYLESS-GO:** point the tip of the key at the door handle on the driver's door.
- **Vehicles with KEYLESS-GO:** the key must be within 2 m of the vehicle.
- **To open all side windows:** press the  button on the key until the side windows are fully opened.
- **To interrupt the opening procedure:** release the  button.

► **To close all side windows:** press the  button on the key until the side windows are fully closed.

► **To interrupt the closing procedure:** release the  button.

Convenience closing with KEYLESS-GO

WARNING

When using the convenience closing feature, make sure that nobody can become trapped. Proceed as follows if there is a risk of entrapment:

- release the sensor surface on the door handle.
- pull the door handle immediately and hold it.

The side windows open.

With KEYLESS-GO you can close all side windows simultaneously. The KEYLESS-GO key must be outside the vehicle. All the doors must be closed.

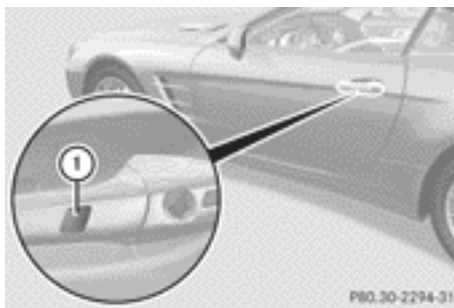

► Touch recessed sensor surface ① on the door handle until the side windows are fully closed.

i Make sure you only touch recessed sensor surface ①.

► Make sure that all the side windows are closed.

► **To interrupt convenience closing:** release recessed sensor surface ① on the door handle.

Resetting the side windows

If a side window can no longer be closed fully, you must reset it.

- ▶ Close all doors.
- ▶ Turn the key to position **1** or **2** in the ignition lock.
- ▶ Pull the corresponding switch on the door control panel until the side window is completely closed. (▷ page 99)
- ▶ Hold the switch for an additional second.

If the side window opens again slightly:

- ▶ immediately pull the corresponding switch on the door control panel until the side window is completely closed (▷ page 99).
- ▶ Hold the switch for an additional second.
- ▶ If the corresponding side window remains closed after the button has been released, the side window has been reset correctly. If this is not the case, repeat the steps above again.

Problems with the side windows

WARNING

Closing the side windows with increased force or without the anti-entrapment feature could lead to serious or even fatal injury. Make sure that nobody can become trapped when closing the side windows.

Problem	Possible causes/consequences and ► Solutions
A side window cannot be closed because it is blocked by objects, e.g. leaves in the window guide.	<ul style="list-style-type: none"> ► Remove the objects. ► Close the side window.
A side window cannot be closed and you cannot see the cause.	<p>If a side window is obstructed during closing and reopens again slightly:</p> <ul style="list-style-type: none"> ► immediately after the window blocks, pull the corresponding switch again until the side window has closed. The side window is closed with increased force. <p>If a side window is obstructed again during closing and reopens again slightly:</p> <ul style="list-style-type: none"> ► immediately after the window blocks, pull the corresponding switch again until the side window has closed. The side window is closed without the anti-entrapment feature.

Roof

Important safety notes

WARNING

Always open or close the roof fully before driving.

If the roof does not open or close fully, the roof hydraulic system is depressurised and the roof is lowered:

- after about seven minutes if the ignition is switched on
- after about 15 seconds if the ignition is switched off

A warning tone sounds shortly beforehand. The  symbol and **Vario-roof lowering** message appear in the multifunction display.

Lock the roof again before driving on. Otherwise, the unlocked roof could open during the journey and cause you to lose control of your vehicle. You and/or other persons could be injured as a result.

WARNING

Closing the roof manually is a complex, technically challenging procedure. Attempting to manually close the roof may cause damage to the roof and/or injury.

For this reason, the manual closing process should only be carried out at a qualified specialist workshop.

- ❗ Never sit on the rear compartment trim or stow heavy objects there. You will otherwise damage the roof and rear compartment trim of the vehicle.

! Do not forget that the weather can change abruptly. Make certain that the roof is closed when you leave the vehicle. The vehicle electronics can be damaged if water enters the vehicle interior.

! When opening and closing the roof, make sure that:

- there is sufficient upward clearance, as the roof swings upwards.
- there is sufficient clearance behind the vehicle, as the boot lid swings backwards beyond the bumper.
- the boot is only loaded to below the boot separator.
- the boot separator is not pushed up by the load.
- the boot separator is closed.
- the boot lid is closed.
- the outside temperature is above -15 °C.

You could otherwise damage the roof, boot and other parts of the vehicle.

i Make sure that the roof and rear window are dry and clean before opening the roof. Otherwise, water or dirt could enter the vehicle interior or boot.

Opening and closing using the roof switch

Important safety notes

⚠ WARNING

When opening or closing the roof, make sure that nobody is trapped or injured by moving parts such as the boot lid, the hinged roof or the roof linkage.

If there is a risk of entrapment, release the roof switch immediately. The roof folding mechanism stops immediately.

Opening and closing

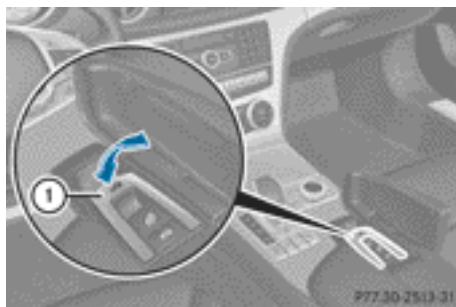



- ▶ Secure the vehicle against rolling away (▷ page 172).
- ▶ Close the boot separator (▷ page 105).
- ▶ Close the boot lid.
- ▶ Turn the key to position **2** in the ignition lock.
- ▶ Open the cover on the lower centre console.
Roof switch ① is located under the cover.
- ▶ **To open:** pull roof switch ① until the roof has been fully retracted into the boot and the **Vario-roof in operation** message disappears from the multifunction display. The front side windows close. The rear side windows open.
- ▶ **To close:** press roof switch ① until the roof is fully closed and the **Vario-roof in operation** message disappears from the multifunction display. All of the side windows close.
- ▶ Make sure that all the side windows are fully closed.

Opening and closing with the key





Important safety notes

⚠ WARNING

When opening or closing the roof, make sure that nobody is trapped or injured by moving parts such as the boot lid, the hinged roof or the roof linkage.

If there is a risk of entrapment, immediately release the  or  button on the key. The roof folding mechanism stops immediately.



Opening and closing

- ▶ Close the boot separator (▷ page 104).
- ▶ Close the boot lid (▷ page 93).
- ▶ **Vehicles without KEYLESS-GO:** point the tip of the key at the door handle on the driver's door.
- ▶ **Vehicles with KEYLESS-GO:** the key must be within 2 m of the vehicle.
- ▶ **To open:** press and hold the  button on the key until the roof is fully opened. The roof and the rear side windows open. The front side windows close.
- ▶ **To interrupt the opening procedure:** release the  button.
- ▶ **To open the front side windows:** press and hold the  button on the key again.
- ▶ **To close:** press and hold the  button on the key until the roof is fully closed. The roof and the side windows close.
- ▶ **To interrupt the closing procedure:** release the  button.
- ▶ **i** The key cannot be used to open the roof if the roof is closed and the boot separator is open. Instead, all of the side windows open or close simultaneously (▷ page 99).

Locking the roof again

Important safety notes

The roof is not locked if:

- the  symbol and **Vario-roof in operation** message appear in the multi-function display
- the  symbol and **Open/close vario-roof completely** message appear and you hear a warning tone
- you hear a warning tone for up to 10 seconds when pulling away or while driving.

Locking

You can lock the roof again if it is not locked fully.

- ▶ Pull over and stop the vehicle safely as soon as possible, paying attention to road and traffic conditions.
- ▶ Make sure the key is in position **2** in the ignition lock.
- ▶ Press the roof switch (▷ page 103).

Boot separator

General notes

- ▶ **!** To avoid damaging the roof or luggage when folding back the roof, you should:
 - only load the boot to below the boot separator
 - not place any objects on or in front of the boot separator
 - not place any objects on the cover behind the roll bars
 - not allow the load to push up the boot separator
- ▶ **!** Make sure that the boot separator is fully closed. Otherwise, the roof could be blocked when opening or closing.

The boot separator can be used to cover luggage and loads in the boot.

Opening and closing

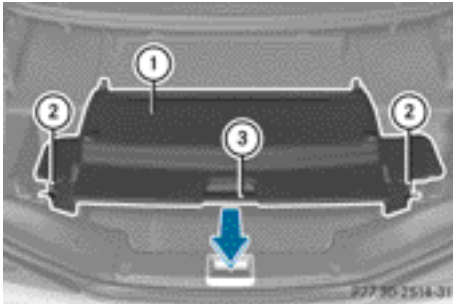

Closed boot separator

- ① Boot separator
- ② Eyelets
- ③ Handle

- ▶ **To close:** pull boot separator ① in the direction of the arrow by handle ③.
- ▶ Hook boot separator ① into fastening eyelets ② in the side panels.
- ▶ **To open:** remove boot separator ① from fastening eyelets ② in the side panels.
- ▶ Push boot separator ① against the direction of the arrow by handle ③.

Removing and fitting

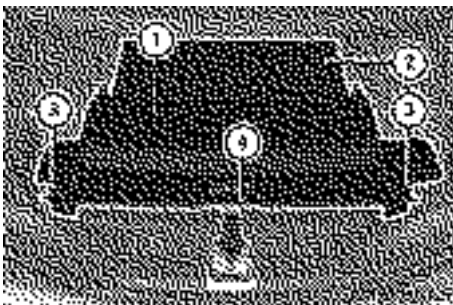

Closed boot separator

- ① Boot separator
- ② Net
- ③ Eyelets
- ④ Handle

- ▶ **To remove:** unhook net ② from the holder on the left and right-hand sides and guide it to the rear until it is completely rolled up.
- ▶ Remove boot separator ① from fastening eyelets ③ in the side panels.
- ▶ Push boot separator ① against the direction of the arrow by handle ④.



Opened boot separator

- ① Boot separator
- ⑤ Catch lever (example: driver's side)
- ▶ Turn driver's side catch lever ⑤ in the direction of the arrow.
- ▶ Repeat the same process on the catch lever on the passenger side. Boot separator ① is unlocked.
- ▶ Pull out boot separator ① in the direction of the arrow.



- ⑤ Catch lever (example: driver's side)
- ⑥ Guide

- ▶ **To install:** insert guides ⑥ of boot separator ① into the brackets.
- ▶ Slide in boot separator ① as far as it will go.
- ▶ Turn driver's side catch lever ⑤ in the direction of the arrow.
- ▶ Repeat the same process on the catch lever on the passenger side. Boot separator ① is unlocked.
- ▶ Pull boot separator ① by handle ④ in the direction of the arrow.
- ▶ Hook boot separator ① into fastening eyelets ③ in the side panels.
- ▶ Pull net ② forwards and hook the left and right-hand sides into the holder.

Draught stop

Manual draught stop

Important safety notes

WARNING

If you use the draught stop in darkness or in other conditions offering poor visibility, your view to the rear is further impaired. As a result of the poor visibility, you could cause an accident and injure yourself or others. For this reason, fold back the draught stop as soon as it is dark or if your vision is otherwise restricted.

WARNING

You could lose control of the vehicle and injure yourself or others if you operate the draught stop while driving.

Fit or remove AIRGUIDE only when the vehicle is stationary.

WARNING

If the draught stop is not correctly engaged, it may break free and obstruct traffic behind you or lead to an accident.

Each time before driving with the roof down, check that the draught stop is properly engaged.

- ❗ Fit or remove the draught stop only when the roof is open. You could otherwise damage the draught stop or the vehicle interior.

The draught stop offers protection from the wind when driving with the roof down.

The draught stop can be fitted or removed from the driver's side or passenger side. We recommend that a second person assists you when doing this.

Perform operations involving the draught stop preferably on the side facing away from traffic, after you have stopped the vehicle, paying attention to road and traffic conditions.

Fitting/removing

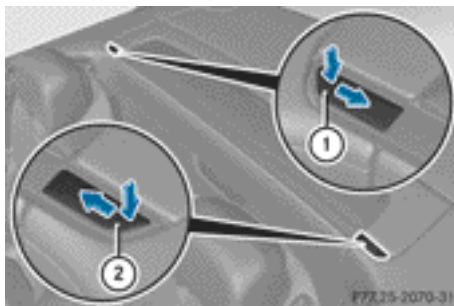

Rear brackets for draught stop

- ① Bracket cover, front-passenger side
- ② Bracket cover, driver's side

- ▶ **To fit:** open the roof (▷ page 103).
- ▶ Press the mark on cover ① and push in the direction of the arrow.
- ▶ Repeat the procedure with cover ②. The rear brackets for draught stop ③ are visible.

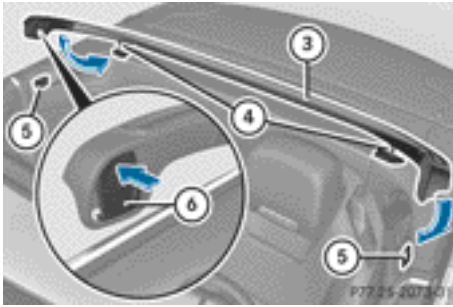

- ③ Draught stop
- ④ Pin
- ⑤ Front brackets for draught stop
- ⑥ Example: lock cover, front-passenger side

- ▶ Make sure that draught stop ③ is folded back.
- ▶ Push the upper half of cover ⑥ on draught stop ③.
- ▶ Repeat the procedure with the cover on the driver's side. Draught stop ③ is unlocked.
- ▶ Hold draught stop ③ at an angle and insert pins ④ into the rear brackets. Make sure that pins ④ sit correctly in the brackets.
- ▶ Insert draught stop ③ into front brackets ⑤.
- ▶ Check whether draught stop ③ is correctly seated in all four brackets.
- ▶ Push the lower half of cover ⑥ on draught stop ③. Draught stop ③ is locked.
- ▶ Fold draught stop ③ forward if necessary.
- ▶ **To remove:** make sure that draught stop ③ is folded back.
- ▶ Push the upper half of cover ⑥ on draught stop ③. Draught stop ③ is unlocked.
- ▶ First remove draught stop ③ from front brackets ⑤.

- ▶ Hold draught stop ③ at an angle and then remove from the rear brackets.
- ▶ Slide covers ① and ② of the rear brackets against the direction of the arrow until they are fully closed.

Electrical draught stop

Important safety notes

WARNING

If you use the draught stop in darkness or in other conditions offering poor visibility, your view to the rear is further impaired. As a result of the poor visibility, you could cause an accident and injure yourself or others. For this reason, retract the draught stop as soon as it is dark or if your vision is otherwise restricted.

- ❗ When extending or retracting the draught stop, make sure there are no objects on the rear compartment trim. Otherwise, the objects could damage the draught stop.

The draught stop offers protection from the wind when driving with the roof down. The roof must be fully open before the draught stop can be extended.

Extending and retracting

- ▶ Open the roof (▷ page 102).
- ▶ Open the cover on the lower centre console. The switch for the electrical draught stop is under the cover.

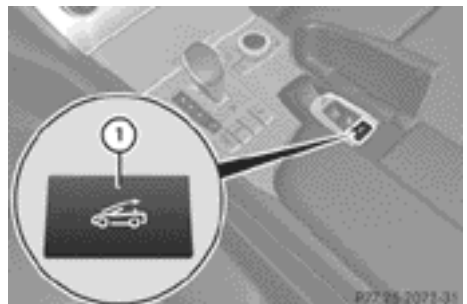

- ▶ **To extend:** press button ①.
- ▶ **To retract:** press button ① again.

Sunblind for the glass roof



The roller sunblind protects you from excessive glare and heat caused by the sun shining through the glass roof.

- ▶ **To close:** using handle ① slide the roller blind in the direction of the arrow.
- ▶ **To open:** using handle ① slide the roller blind in the opposite direction to the arrow.

MAGIC SKY CONTROL

General notes

MAGIC SKY CONTROL is a glass roof, the transparency of which can be changed by applying electrical voltage.

MAGIC SKY CONTROL can be switched between darkened and transparent states.

- ❗ **MAGIC SKY CONTROL** darkens automatically when you turn the key to position **0** in the ignition lock or remove the key.

Risk of electric shock

DANGER

The MAGIC SKY CONTROL electrical system works under high voltage.

If the covering behind the overhead control panel is damaged or removed, electric components of the MAGIC SKY CONTROL system

will be exposed. These components could be live. If you touch these components, you could receive an electric shock, which could cause a severe or fatal injury.

For this reason, never remove the covering behind the overhead control panel. Never touch electrical system components (control unit, cables or cable connections).

Always have any work on the MAGIC SKY CONTROL carried out at a qualified specialist workshop.

The electrical components of MAGIC SKY CONTROL are protected by a covering behind the overhead control panel.

The MAGIC SKY CONTROL control unit has a yellow high-voltage warning sticker. The high-voltage cables are orange.

MAGIC SKY CONTROL operation

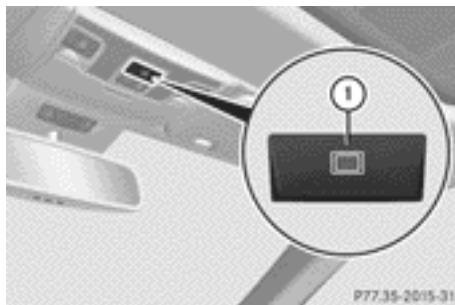

- ▶ Turn the key to position **1** or **2** in the ignition lock.
MAGIC SKY CONTROL switches to the status it was set to before the engine was switched off.
- ▶ **To change the degree of transparency:** press button ①.

- ❗ At sub-zero temperatures, the change is slower and uneven. The entire process may take some time.

Problems with the roof	
Problem	Possible causes/consequences and ► Solutions
The roof will not open or close.	The boot separator is not in place. ► Close the boot separator (▷ page 105).
	The boot lid is open. ► Close the boot lid (▷ page 94).
	The on-board voltage is too low. ► Leave the engine running.
	The roof has been opened and closed several times in a row. The roof drive has been automatically deactivated. You can open and close the roof again after approximately ten minutes. ► Switch off the ignition and turn it back on. ► Repeat the opening or closing procedure.
	The automatic roof mechanism is faulty. ► Consult a qualified specialist workshop.

Useful information	112
Correct driver's seat position	112
Seats	113
Steering wheel	118
Mirrors	119
Memory function	122

Useful information

i This Owner's Manual describes all models, series and optional equipment for your vehicle that were available at the time of going to press. National variations are possible. Note that your vehicle may not be equipped with all of the functions described. This is also the case for systems and functions relevant to safety.

i Read the information on qualified specialist workshops: (▷ page 38).

Correct driver's seat position



- ▶ Observe the safety guidelines on seat adjustment (▷ page 113).
- ▶ Make sure that seat ③ is adjusted properly.

Electrical seat adjustment (▷ page 114)

When adjusting the seat, make sure that:

- you are as far away from the driver's airbag as possible.
- you are sitting in a normal upright position.
- you can fasten the seat belt properly.
- you have moved the backrest to an almost vertical position.

- you have set the seat angle so that your thighs are gently supported.
- you can depress the pedals properly.

- ▶ Check whether the head restraint is adjusted properly.

When doing so, make sure that you have adjusted the head restraint so that the back of your head is supported at eye level by the centre of the head restraint.

- ▶ Observe the safety guidelines on steering wheel adjustment (▷ page 118).
- ▶ Make sure that steering wheel ① is adjusted properly.

Adjusting the steering wheel electrically (▷ page 118)

When adjusting the steering wheel, make sure that:

- you can hold the steering wheel with your arms slightly bent.
- you can move your legs freely.
- you can see all the displays in the instrument cluster clearly.
- ▶ Observe the safety guidelines for seat belts (▷ page 61).
- ▶ Check whether you have fastened seat belt ② properly (▷ page 62).

The seat belt should:

- fit snugly across your body
- be routed across the middle of your shoulder
- be routed in your pelvic area across the hip joints
- ▶ Before starting off, adjust the rear-view mirror and the exterior mirrors (▷ page 119) in such a way that you have a good view of road and traffic conditions.
- ▶ Store the seat, steering wheel and exterior mirror settings using the memory function (▷ page 122).

Seats

Important safety notes

WARNING

The seats can still be adjusted when there is no key in the ignition lock. For this reason, children should never be left unsupervised in the vehicle. They could adjust the seats and become trapped.

WARNING

Only adjust the driver's seat when the vehicle is stationary. You will otherwise be distracted from the road and traffic conditions and you could lose control of the vehicle as a result of the seat moving. This could cause an accident.

WARNING

If you adjust the seat height carelessly, you or others could be trapped and thereby injured. Children in particular could unintentionally press the buttons to electrically adjust the seats and become trapped.

Take care that:

- while moving the seats, your hands do not get under the lever assembly of the seat adjustment system.
- children in the vehicle do not slide their hands under the levers.

WARNING

Make sure that nobody can become trapped when adjusting the seats.

Observe the notes on airbags.

Secure children as recommended; see the "Children in the vehicle" section.

WARNING

Make sure that nobody can become trapped when adjusting the seats.

Observe the notes on airbags.

Secure children as recommended; see the "Children in the vehicle" section.

WARNING

Make sure that the back of your head is supported at eye level by the central area of the head restraint. If your head is not supported correctly by the head restraint, you could suffer a severe neck injury in the event of an accident. Never drive if the head restraints are not engaged and set correctly.

WARNING

A seat belt can only offer its intended degree of protection when the backrest is almost vertical and the occupant is sitting upright. Avoid seat positions that do not allow the seat belt to be routed correctly. Adjust the backrest so that it is as upright as possible. Never travel with the backrest reclined too far backwards. You could otherwise be seriously or even fatally injured in the event of an accident or sudden braking.

 To avoid damage to the seats and the seat heating, observe the following information:

- do not spill any liquids on the seats. If liquid is spilled on the seats, dry them as soon as possible.
- if the seat covers are damp or wet, do not switch on the seat heating. The seat heating should also not be used to dry the seats.
- clean the seat covers as recommended; see the "Interior care" section.
- do not transport heavy loads on the seats. Do not place sharp objects on the seat cushions, e.g. knives, nails or tools. The seats should only be occupied by passengers, if possible.
- when the seat heating is in operation, do not cover the seats with insulating materials, e.g. blankets, coats, bags, seat covers, child seats or booster seats.

! To avoid damage to the seats and the seat heating, observe the following information:

- do not spill any liquids on the seats. If liquid is spilled on the seats, dry them as soon as possible.
- if the seat covers are damp or wet, do not switch on the seat heating. The seat heating should also not be used to dry the seats.
- clean the seat covers as recommended; see "Interior care".
- do not transport heavy loads on the seats. Do not place sharp objects on the seat cushions, e.g. knives, nails or tools. The seats should only be occupied by passengers, if possible.
- when the seat heating is in operation, do not cover the seats with insulating materials, e.g. blankets, coats, bags, seat covers, child seats or booster seats.

! Make sure that there are no objects in the footwell or behind the seats when moving the seat back. There is a risk that the seats and/or the objects could be damaged.

- i** The head restraints cannot be removed. For more information, contact a qualified specialist workshop.

- ④ Seat cushion length
- ⑤ Seat fore-and-aft adjustment
- ⑥ Backrest angle

i Further related subjects:

- You can store the seat settings using the memory function (▷ page 122).
- If PRE-SAFE® is triggered, the front-passenger seat will be moved to a better position if it was previously in an unfavourable position (▷ page 60).

Adjusting the front-passenger seat from the driver's seat

⚠ WARNING

When adjusting a front-passenger seat that is occupied, make sure that it is as far away from the front-passenger airbag as possible. The front passenger could otherwise sustain serious or fatal injuries in the event of an accident or braking manoeuvre.

Make sure that nobody can become trapped when adjusting the seat.

The front-passenger seat can be adjusted when there is no key in the ignition lock. For this reason, children should never be left unsupervised in the vehicle. They could become trapped if the seats move.

! Do not move the front-passenger seat fully forwards if there are objects in the luggage net in the front-passenger footwell. The objects could otherwise be damaged.

Adjusting the seats electrically

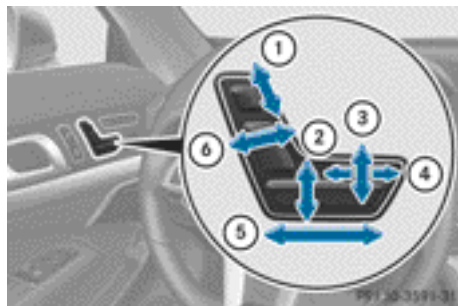

- ① Head restraint height
- ② Seat height
- ③ Seat cushion angle

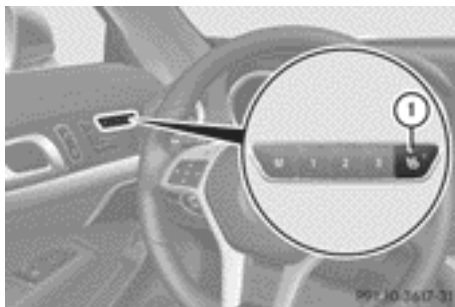

You can use the seat switches on the driver's side to adjust the front-passenger seat.

► **To activate/deactivate:** press button ①.

If the indicator lamp in button ① is lit, you can access the following functions for the front-passenger seat:

- seat adjustment
- memory function

Removing the seat belt from the seat belt guide

⚠ WARNING

If the seat belt is not in the seat belt guide, it no longer offers the intended level of protection in the event of an accident. This increases the risk of injury.

When driving, always route the seat belt through the seat belt guide.

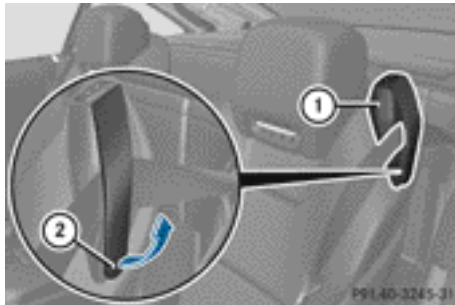

Both the driver's seat belt and the front-passenger seat belt can be removed from the seat belt guide. This makes it easier to move the seats forward.

Before you drive off, the seat belt must be inserted into the seat belt guide.

Observe the safety guidelines for seat belts (► page 61).

- **To remove:** open up magnetic head ② and fold the tab up in the direction of the arrow.
- Take the seat belt out of seat belt guide ①.

- **To insert:** fold the tab up in the direction of the arrow.
- Insert the seat belt back into the seat belt guide and fold the tab back down.

Adjusting the head restraints

Adjusting the head restraints electrically

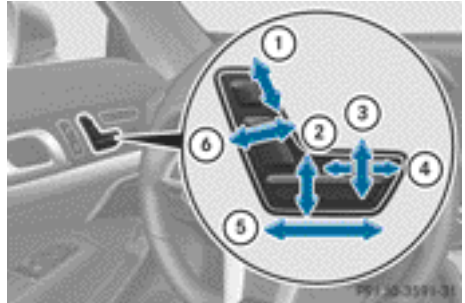

- ① Backrest angle
- ① Head restraint height
- ② Seat fore-and-aft adjustment
- ② Seat height
- ③ Seat cushion angle
- ④ Seat height
- ④ Seat cushion length
- ⑤ Seat fore-and-aft adjustment
- ⑥ Backrest angle

- **To adjust the head restraint height:** slide switch for head restraint adjustment (► page 114) ① up or down in the direction of the arrow.

Sliding the seats forward/back

⚠ WARNING

Make sure that nobody can become trapped when moving the seat. If there is a risk of someone becoming trapped, press the button again or press the seat adjustment switch on the door.

! Make sure that there are no containers in the cup holder and no objects in the footwell or behind the seats when adjusting the seats. Otherwise, you could damage the seats and the objects.

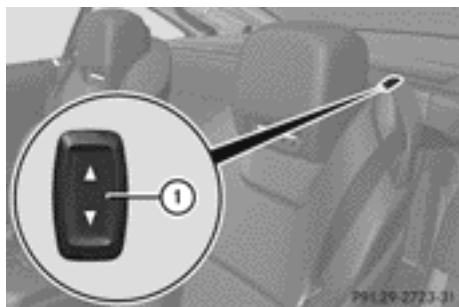

You can move the seat forwards, in order to gain better access to the rear compartment, e.g. to reach the stowage compartment in the rear (▷ page 514).

- ▶ Remove the seat belt from the seat belt guide (▷ page 115).
- ▶ **To move the seat forwards:** press on switch ①.
The seat moves automatically to the foremost position.
- ▶ **To move the seat backwards:** press on switch ①.
The seat moves back to the previous position.
- ▶ **To stop seat movement:** press or in the opposite direction.

Adjusting the multicontour seat

You can set the multicontour seat using COMAND Online (▷ page 311).

Adjusting the active multicontour seat

You can set the active multicontour seat using COMAND Online (▷ page 311).

Adjusting the 4-way lumbar support

You can adjust the 4-way lumbar support with COMAND Online (▷ page 311).

Switching the seat heating on/off

Switching on/off

⚠ WARNING

Repeatedly setting the seat heating to level **3** may result in excessive seat temperatures. The health of passengers that have limited temperature sensitivity or a limited ability to react to excessively high temperatures may be affected or they may even suffer burn-like injuries. Therefore, do not use seat heating level **3** repeatedly.



Driver's and front-passenger seat

The three red indicator lamps in the button indicate the heating level you have selected. The system automatically switches down from level **3** to level **2** after approximately eight minutes.

The system automatically switches down from level **2** to level **1** after approximately ten minutes.

The system automatically switches off approximately 20 minutes after it is set to level **1**.

You can set the distribution of the heated sections of the seat cushion and backrest using COMAND Online (▷ page 312).

- ▶ Make sure that the key is in position **1** or **2** in the ignition lock.
- ▶ **To switch on:** press button ① repeatedly until the desired heating level is set.
- ▶ **To switch off:** press button ① repeatedly until all the indicator lamps go out.

i If the battery voltage is too low, the seat heating may switch off.

Problems with the seat heating

The seat heating has switched off prematurely or cannot be switched on. The vehicle's electrical system voltage is too low because too many electrical consumers are switched on.

- ▶ Switch off electrical consumers that you do not need, such as the rear window heating or interior lighting.
- ▶ Once the battery is sufficiently charged, switch the seat heating back on.

Switching the seat ventilation on/off

Switching on/off

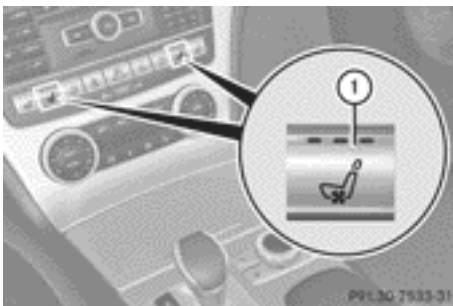

The three blue indicator lamps in the buttons indicate the ventilation level you have selected.

- ▶ Make sure that the key is in position **1** or **2** in the ignition lock.
- ▶ **To switch on:** press button ① repeatedly until the desired ventilation level is set.
- ▶ **To switch off:** press button ① repeatedly until all the indicator lamps go out.

i If the battery voltage is too low, the seat ventilation may switch off.

i If you open the roof with the key (▷ page 104), the seat ventilation of the driver's seat switches on automatically and the side windows open.

Problems with the seat ventilation

The seat ventilation has switched off prematurely or cannot be switched on. The vehicle's electrical system voltage is too low because too many electrical consumers are switched on.

- ▶ Switch off electrical consumers that you do not need, such as the rear window heating or interior lighting.

AIRSCARF

Switching on/off

WARNING

Very hot air can flow out of the AIRSCARF vents in the head restraints when AIRSCARF is in operation. This can cause burns on unprotected skin near the AIRSCARF vents. Lower the heating output in good time, when necessary.

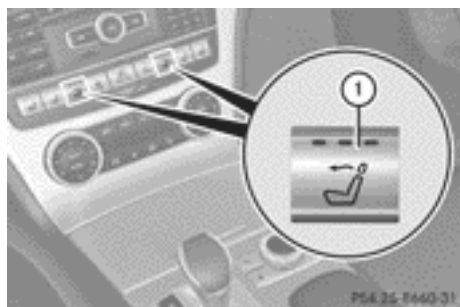

The AIRSCARF function warms the head and neck area of vehicle occupants with warm air. The warm air flows out of the holes in the head restraints.

The three red indicator lamps in the button indicate the heating level you have selected.

► Make sure that the key is in position **2** in the ignition lock.

► **To switch on:** press the ① button.

Three red indicator lamps in the button light up. The blower starts up after a preheating phase of seven seconds.

► Press button ① repeatedly until the desired heating level is set.

► **To switch off:** press button ① repeatedly until all the indicator lamps go out.

i The blower continues running for seven seconds to cool down the heating elements.

i If the battery voltage is too low, AIRSCARF may switch off.

Steering wheel

Important safety notes

⚠ WARNING

Do not adjust the steering wheel while driving. Adjusting the steering wheel while driving could cause the driver to lose control of the vehicle.

The electrical steering wheel adjustment can be operated at any time. Therefore, do not

leave children unattended in the vehicle or with access to an unlocked vehicle. Children having unsupervised access to a vehicle could result in an accident and/or serious personal injury.

Adjusting the steering wheel electrically

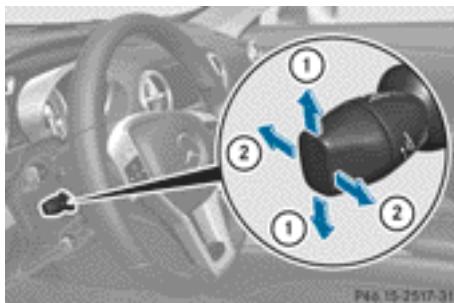

① To adjust the steering wheel height

② To adjust the steering wheel position (fore-and-aft adjustment)

i Further related subjects:

- EASY-ENTRY/EXIT feature (> page 118)
- storing settings (> page 122)

EASY-ENTRY/EXIT feature

Important safety notes

⚠ WARNING

Make sure that nobody can become trapped when you activate the EASY-ENTRY/EXIT feature.

If there is a risk of someone becoming trapped, stop the adjustment procedure. To halt the procedure:

- press the steering column adjustment button.
- briefly press one of the memory function position buttons.

The steering column stops moving immediately.

Do not keep the memory function position button pressed down, otherwise the memory function will start and the steering wheel and seat will begin to move.

Never leave children unsupervised in the vehicle. They could open the driver's door and thereby unintentionally activate the EASY-ENTRY feature and become trapped.

The EASY-ENTRY/EXIT feature makes getting in and out of your vehicle easier.

You can activate and deactivate the EASY-ENTRY/EXIT feature in the on-board computer (▷ page 237).

Position of the steering wheel when the EASY-ENTRY/EXIT feature is active

The steering wheel tilts upwards if you:

- remove the key from the ignition lock
- open the driver's door and KEYLESS-GO is in position **1**
- open the driver's door and the key is in position **0** or **1** in the ignition lock

i The steering wheel only moves upwards if it has not already reached the upper end stop.

Position of the steering wheel for driving

The steering wheel is moved to the previously set position if:

- the driver's door is closed and
- you insert the key into the ignition lock or
- you press the Start/Stop button once on vehicles with KEYLESS-GO.

If you close the driver's door with the key inserted into the ignition lock, the steering wheel is automatically moved to the previously set position.

The last position of the steering wheel is stored when you switch off the ignition or when you store the setting with the memory function (▷ page 122).

Crash-responsive EASY-EXIT feature

If the crash-responsive EASY-EXIT feature is triggered in an accident, the steering column will move upwards when the driver's door is opened. This occurs irrespective of the position of the key in the ignition lock. This makes it easier to exit the vehicle and rescue the occupants.

The crash-responsive EASY-EXIT feature is only operational if the EASY-EXIT/ENTRY feature is activated in the on-board computer.

Mirrors

Rear-view mirror



► **Anti-dazzle mode:** flick anti-dazzle switch **1** forwards or back.

Exterior mirrors

Adjusting the exterior mirrors

⚠ WARNING

The exterior mirrors reduce the size of the image. Objects are actually closer than they appear. You could misjudge the distance from vehicles driving behind and cause an accident, e.g. when changing lane. For this reason, make sure of the actual distance from the

vehicle driving behind by glancing over your shoulder.



- ▶ Make sure that the key is in position 1 or 2 in the ignition lock.
- ▶ Press button ① for the left-hand exterior mirror or button ② for the right-hand exterior mirror.

The indicator lamp in the corresponding button lights up in red.

The indicator lamp goes out again after some time. You can adjust the selected mirror using adjustment button ③ as long as the indicator lamp is lit.

- ▶ Press adjustment button ③ up, down, to the right or to the left. The exterior mirror must be set to a position that provides you with a good overview of traffic conditions.

The convex exterior mirrors provide a larger field of vision.

After the engine has been started, the exterior mirrors are automatically heated if the rear window heating is switched on and the outside temperature is low. Heating takes a maximum of 10 minutes.

- ❗ The exterior mirrors can also be heated manually by switching on the rear window heating.

Folding the exterior mirrors in or out electrically

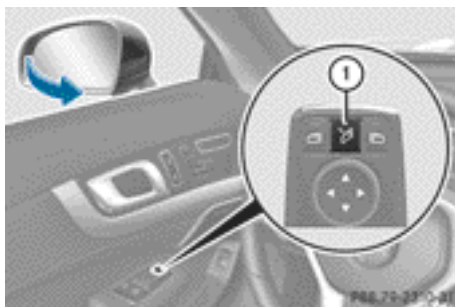

- ▶ Make sure that the key is in position 1 or 2 in the ignition lock.
- ▶ Briefly press button ①. Both exterior mirrors fold in or out.

- ❗ Make sure that the exterior mirrors are always folded out fully while driving. They could otherwise vibrate.

Setting the exterior mirrors

If the battery has been disconnected or completely discharged, the exterior mirrors must be reset. The exterior mirrors will otherwise not fold in when you select the "Fold in mirrors when locking" function in the on-board computer (▷ page 237).

- ▶ Make sure that the key is in position 1 in the ignition lock.
- ▶ Briefly press button ①.

Folding the exterior mirrors in/out automatically

If the "Fold in mirrors when locking" function is activated in the on-board computer (▷ page 237):

- the exterior mirrors fold in automatically as soon as you lock the vehicle from the outside.
- the exterior mirrors fold out again automatically as soon as you unlock the vehicle and then open the driver's or front-passenger door.

- i** The exterior mirrors do not fold out if they have been folded in manually.

Exterior mirror pushed out of position

If an exterior mirror has been pushed out of position, proceed as follows:

- ▶ **Vehicles without electrically folding exterior mirrors:** move the exterior mirror into the correct position manually.
- ▶ **Vehicles with electrically folding exterior mirrors:** press and hold mirror-folding button ① until you hear a click and then the mirror engage in position (▷ page 120).
The mirror housing is engaged again and you can adjust the exterior mirrors as usual (▷ page 119).

Automatic anti-dazzle mirrors

WARNING

If incident light from headlamps is prevented from striking the sensor in the rear-view mirror, for instance, by luggage piled too high in the vehicle, the mirror's automatic anti-dazzle function will not operate.

Incident light could then blind you. This may distract you from the traffic conditions and, as a result, you may cause an accident.

The rear-view mirror and the exterior mirror on the driver's side automatically go into anti-dazzle mode if the following conditions are met simultaneously:

- the ignition is switched on and
- incident light from headlamps strikes the sensor in the rear-view mirror.

The mirrors do not go into anti-dazzle mode if reverse gear is engaged or if the interior lighting is switched on.

Parking position of the exterior mirror on the front-passenger side

Setting and storing the parking position

Using reverse gear

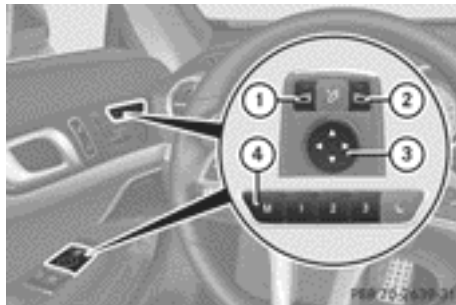

- ① Button for the exterior mirror on the driver's side
- ② Button for the exterior mirror on the front-passenger side
- ③ Adjustment button
- ④ Memory button **M**

You can set the front-passenger side exterior mirror so that you can see the rear wheel on that side as soon as you engage reverse gear. You can store this position.

- ▶ Make sure that the vehicle is stationary and that the key is in position **2** in the ignition lock.
- ▶ Press button ② for the exterior mirror on the front-passenger side.
- ▶ Engage reverse gear.
The exterior mirror on the front-passenger side moves to the preset parking position.
- ▶ Use adjustment button ③ to adjust the exterior mirror to a position that allows you to see the rear wheel and the kerb.
The parking position is stored.

- i** If you shift the transmission to another position, the exterior mirror on the front-passenger side returns to the driving position.

Using the memory button



- ① Button for the exterior mirror on the driver's side
- ② Button for the exterior mirror on the front-passenger side
- ③ Adjustment button
- ④ Memory button **M**

You can set the front-passenger side exterior mirror so that you can see the rear wheel on that side as soon as you engage reverse gear. This setting can be stored using memory button **M** ④.

- ▶ Make sure that the key is in position **2** in the ignition lock.
- ▶ With the exterior mirror on the front-passenger side activated, use adjustment button ③ to adjust the exterior mirror. In the exterior mirror, the rear wheel and the kerb should be visible.
- ▶ Press memory button **M** ④ and one of the arrows on adjustment button ③ within three seconds.
The parking position is stored if the exterior mirror does not move.
- ▶ If the mirror moves out of position, repeat the steps.

Calling up a stored parking position setting

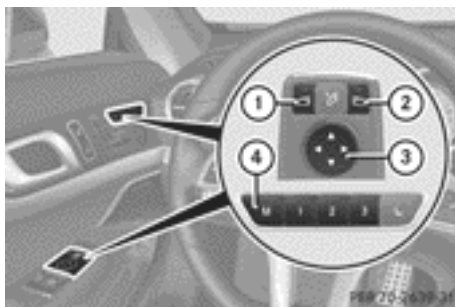

- ① Button for the exterior mirror on the driver's side
- ② Button for the exterior mirror on the front-passenger side
- ③ Adjustment button
- ④ Memory button **M**

- ▶ Turn the key to position **2** in the ignition lock.
- ▶ Adjust the exterior mirror on the front-passenger side using button ②.
- ▶ Engage reverse gear.
The exterior mirror on the front-passenger side moves to the stored parking position.

The exterior mirror on the front-passenger side moves back to its original position:

- as soon as you exceed a speed of 15 km/h
- if you press button ① for the exterior mirror on the driver's side

Memory function

Storing settings

⚠ WARNING

Only use the memory function on the driver's side when the vehicle is stationary. You could otherwise be distracted from the traffic conditions by the steering wheel and seat moving of their own accord, and as a result, cause an accident.

WARNING

The memory function can still be used when the key has been removed. For this reason, children should never be left unsupervised in the vehicle. They could otherwise become trapped when adjusting the seat or the steering wheel.

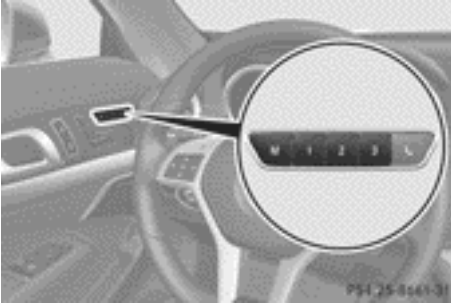

- ▶ Adjust the seat electrically (▷ page 114).
- ▶ On the driver's side, adjust the steering wheel (▷ page 118) and the exterior mirrors (▷ page 119).
- ▶ Press the **M** memory button and then press storage position button **1**, **2** or **3** within three seconds.
The settings are stored in the selected pre-set position. A tone sounds when the settings have been completed.

Calling up a stored setting

- ▶ Press and hold the relevant storage position button **1**, **2** or **3** until the seat, steering wheel and exterior mirrors are in the stored position.
- i** The setting procedure is interrupted as soon as you release the storage position button.

Useful information	126
Exterior lighting	126
Interior lighting	133
Replacing bulbs	134
Windscreen wipers	135

Useful information

i This Owner's Manual describes all models, series and optional equipment for your vehicle that were available at the time of going to press. National variations are possible. Note that your vehicle may not be equipped with all of the functions described. This is also the case for systems and functions relevant to safety.

i Read the information on qualified specialist workshops: (▷ page 38).

Exterior lighting

General notes

For reasons of safety, Mercedes-Benz recommends that you drive with the lights switched on even during the daytime. In some countries, operation of the headlamps varies due to legal requirements and self-imposed obligations.

Driving abroad

Symmetrical dipped-beam headlamps

If your journey takes you to countries where vehicles are driven on the opposite side of the road to the country in which the vehicle is registered, your headlamps must be switched to symmetrical dipped beam. This prevents oncoming traffic from being dazzled. Symmetrical lights do not illuminate as large an area of the edge of the carriageway.

Convert the headlamps as close to the border as possible before driving in these countries (▷ page 234).

Asymmetrical dipped beam

Convert the headlamps back to asymmetrical dipped beam as soon as possible after crossing the border (▷ page 234).

If the headlamps are converted to symmetrical dipped beam, the "motorway mode" and

"extended range foglamps" functions (Intelligent Light System) are not available.

Setting the exterior lighting

Setting options

Exterior lighting can be set using the:

- light switch
- combination switch (▷ page 129)
- on-board computer (▷ page 234)

Light switch

Operation

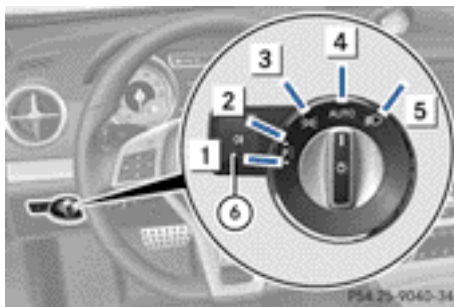

- 1** Left-hand parking lamps
- 2** Right-hand parking lamps
- 3** Side lamps, licence plate and instrument cluster lighting
- 4** **AUTO** Automatic headlamp mode, controlled by the light sensor
- 5** Dipped-beam/main-beam headlamps
- 6** Rear foglamp

If you hear a warning tone when you leave the vehicle, the lights may still be switched on.

► Turn the light switch to **AUTO**.

The exterior lighting (except the side lamps/parking lamps) switches off automatically if you:

- remove the key from the ignition lock
- open the driver's door with the key in position **0**.

Automatic headlamp mode





WARNING

When the light switch is set to **AUTO**, the dipped-beam headlamps may not be switched on automatically if there is fog, snow or other causes of poor visibility due to the weather conditions such as spray. There is a risk of an accident.

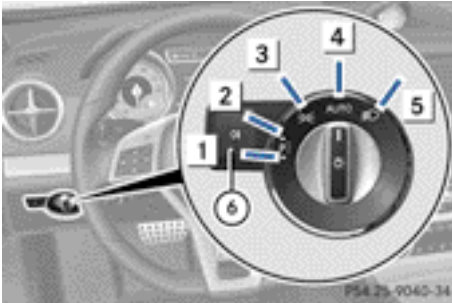
In such situations, turn the light switch to .

The automatic headlamp feature is only an aid. The driver is responsible for the vehicle's lighting at all times.



- 1  Left-hand parking lamps
- 2  Right-hand parking lamps
- 3  Side lamps, licence plate and instrument cluster lighting
- 4 **AUTO** Automatic headlamp mode, controlled by the light sensor
- 5  Dipped-beam/main-beam headlamps
- 6  Rear foglamp

AUTO is the preferred light switch setting. The light setting is automatically selected according to the brightness of the ambient light (exception: poor visibility due to weather conditions such as fog, snow or spray):

- Key in position 1 in the ignition lock: the side lamps are switched on or off automatically depending on the brightness of the ambient light.
- With the engine running: if you have activated the "daytime driving lights" function

in the on-board computer, the daytime driving lights or the parking lamps and dipped-beam headlamps are switched on or off automatically depending on the brightness of the ambient light.

- **To switch on automatic headlamp mode:** turn the light switch to **AUTO**.

The daytime driving lights improve the detectability of your vehicle during the day. Here, the daytime driving lights function must be switched on via the on-board computer (> page 234).

When the dipped-beam headlamps are switched on, the green  indicator lamp in the instrument cluster lights up and the daytime driving lights are switched off or dim.



Dipped-beam headlamps

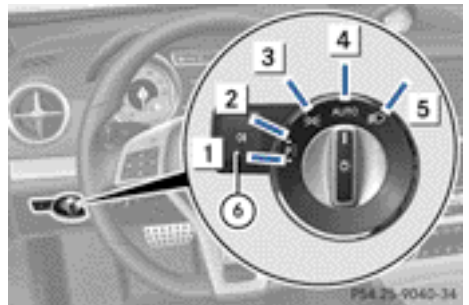

WARNING

When the light switch is set to **AUTO**, the dipped-beam headlamps may not be switched on automatically if there is fog, snow or other causes of poor visibility due to the weather conditions such as spray. There is a risk of an accident.



In such situations, turn the light switch to .



- 1  Left-hand parking lamps
- 2  Right-hand parking lamps
- 3  Side lamps, licence plate and instrument cluster lighting
- 4 **AUTO** Automatic headlamp mode, controlled by the light sensor





- 5  Dipped-beam/main-beam headlamps
- 6  Rear foglamp

When the ignition is switched on and the light switch is in position , the side lamps and dipped-beam headlamps are switched on even if the light sensor does not sense dark ambient light conditions. This is advantageous when there is fog or rain.

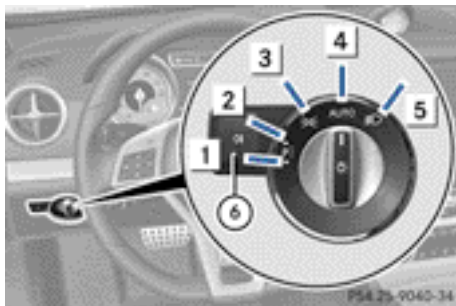



- ▶ **To switch on the dipped-beam headlamps:** turn the key in the ignition lock to position **2** or start the engine.
- ▶ Turn the light switch to . The green  indicator lamp in the instrument cluster lights up.

Rear foglamp





- 1  Left-hand parking lamps
- 2  Right-hand parking lamps
- 3  Side lamps, licence plate and instrument cluster lighting
- 4 **AUTO** Automatic headlamp mode, controlled by the light sensor
- 5  Dipped-beam/main-beam headlamps
- 6  Rear foglamp





The rear foglamp improves the visibility of your vehicle in heavy fog for the following traffic. Please observe the country-specific laws on the use of rear foglamps.

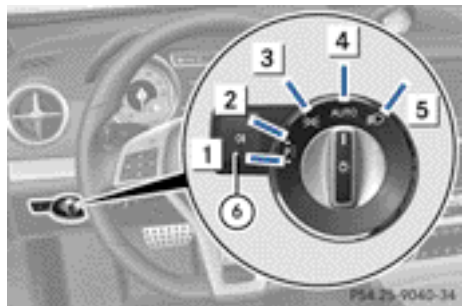

- ▶ **To switch on the rear foglamp:** turn the key in the ignition lock to position **2** or start the engine.
- ▶ Turn the light switch to  or **AUTO**.
- ▶ Press the  button. The yellow  indicator lamp in the instrument cluster lights up.
- ▶ **To switch off the rear foglamp:** press the  button. The yellow  indicator lamp in the instrument cluster goes out.

Side lamps

- ⓘ If the battery has been excessively discharged, the side lamps or parking lamps are automatically switched off to enable the next engine start. Always park your vehicle safely and sufficiently lit according to legal standards. Avoid the continuous use of the  side lamps for several hours. If possible, switch on the  right or the  left parking lamp.



- 1  Left-hand parking lamps
- 2  Right-hand parking lamps
- 3  Side lamps, licence plate and instrument cluster lighting
- 4 **AUTO** Automatic headlamp mode, controlled by the light sensor
- 5  Dipped-beam/main-beam headlamps
- 6  Rear foglamp

- ▶ **To switch on:** turn light switch to . **AMG vehicles:** the green  indicator lamp in the instrument cluster lights up.

Parking lamps

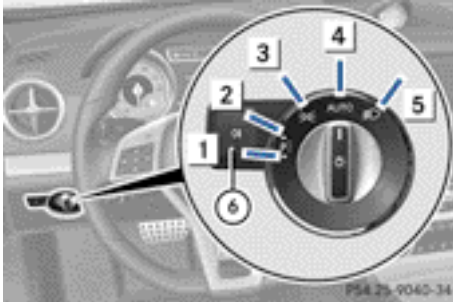

- 1 Left-hand parking lamps
- 2 Right-hand parking lamps
- 3 Side lamps, licence plate and instrument cluster lighting
- 4 Automatic headlamp mode, controlled by the light sensor
- 5 Dipped-beam/main-beam headlamps
- 6 Rear foglamp

Switching on the parking lamps ensures the corresponding side of the vehicle is illuminated.

- ▶ **To switch on the parking lamps:** the key is not in the ignition lock or it is in position 0.
- ▶ Turn the light switch to (left-hand side of the vehicle) or (right-hand side of the vehicle).

Combination switch

Turn signals

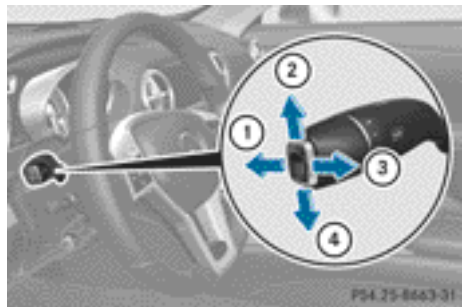

- 1 Main-beam headlamps
- 2 Turn signal, right
- 3 Headlamp flasher
- 4 Turn signal, left

- ▶ **To indicate briefly:** press the combination switch briefly to the pressure point in the direction of arrow ② or ④.

The corresponding turn signal flashes three times.

- ▶ **To indicate:** press the combination switch beyond the pressure point in the direction of arrow ② or ④.

Main-beam headlamps

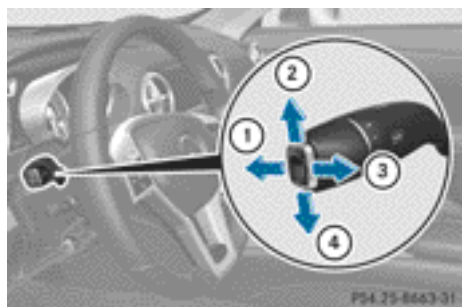

- 1 Main-beam headlamps
- 2 Turn signal, right
- 3 Headlamp flasher
- 4 Turn signal, left

- ▶ **To switch on the main-beam headlamps:** turn the key in the ignition lock to position **2** or start the engine.
- ▶ Turn the light switch to  or **AUTO**.
- ▶ Press the combination switch beyond the pressure point in the direction of arrow ①.

In the **AUTO** position, the main-beam headlamps are only switched on when it is dark and the engine is running.

The  indicator lamp in the instrument cluster lights up when the main-beam headlamps are switched on.

- ▶ **To switch off the main-beam headlamps:** move the combination switch back to its normal position.
- The  indicator lamp in the instrument cluster goes out.

Headlamp flasher

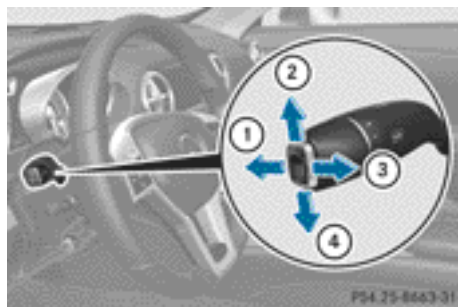

- ① Main-beam headlamps
- ② Turn signal, right
- ③ Headlamp flasher
- ④ Turn signal, left

- ▶ **To switch on:** turn the key in the ignition lock to position **1** or **2** or start the engine.
- ▶ Pull the combination switch in the direction of arrow ③.

Hazard warning lamps



- ▶ **To switch on the hazard warning lamps:** press button ①.
- All turn signals flash. If you now switch on a turn signal using the combination switch, only the turn signal lamp on the corresponding side of the vehicle will flash.
- ▶ **To switch off the hazard warning lamps:** press button ①.

The hazard warning lamps automatically switch on if:

- an airbag is deployed.
- the vehicle decelerates rapidly from a speed of more than 70 km/h and comes to a standstill.

The hazard warning lamps switch off automatically if the vehicle reaches a speed of over 10 km/h again after a full brake application.

- ❗ The hazard warning lamps still operate if the ignition is switched off.

Headlamp cleaning system

The headlamps are cleaned automatically if the "Wipe with washer fluid" function is operated five times (▷ page 135) while the lights are on and the engine is running. When you switch off the ignition, the automatic headlamp cleaning system is reset and counting is resumed from 0.

Intelligent Light System

General notes

The Intelligent Light System is a system that adjusts the headlamps automatically to suit the prevailing driving and weather conditions. It offers advanced functions for improved illumination of the road surface, e.g. depending on the vehicle speed or weather conditions. The system includes the active light function, cornering light function, motorway mode and extended range foglamps. The system is only active when it is dark.

You can activate or deactivate the "Intelligent Light System" using the on-board computer (▷ page 234).

Active light function

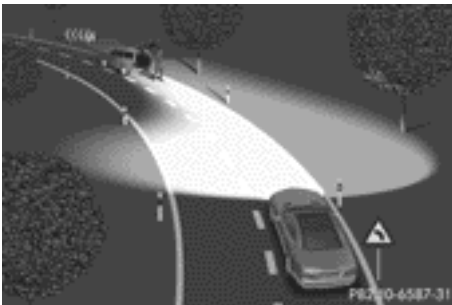

The active light function is a system that moves the headlamps according to the steering movements of the front wheels. In this way, relevant areas remain illuminated while driving. This allows you to recognise pedestrians, cyclists and animals.

Active: when the lights are switched on.

Cornering light function



The cornering light function improves the illumination of the road over a wide angle in the direction you are turning, enabling better visibility in tight bends, for example. The cornering light function can only be activated when the dipped-beam headlamps are switched on.

Active:

- if you are driving at speeds below 40 km/h and switch on the turn signal or turn the steering wheel.
- if you are driving at speeds between 40 km/h and 70 km/h and turn the steering wheel.

Not active: if you are driving at speeds above 40 km/h or switch off the turn signal or turn the steering wheel to the straight-ahead position.

The cornering lamp may remain lit for a short time, but is automatically switched off after no more than three minutes.

Motorway mode



Motorway mode increases the range of the beam.

Active:

- if you are driving at speeds above 110 km/h and do not make any large steering movements for 1,000 m
- if you are driving at speeds above 130 km/h

Not active: if you are driving at speeds below 80 km/h following activation.

Extended range foglamps

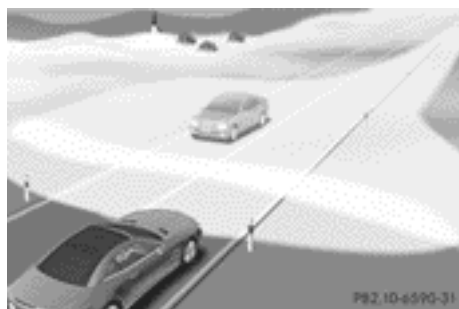

The extended range foglamps reduce the glare experienced by the driver and improve the illumination of the edge of the carriageway.

Active: if you are driving at speeds below 70 km/h and you switch on the rear foglamp.

Not active: if you are driving at speeds above 100 km/h or if you switch off the rear foglamp following activation.

Adaptive Highbeam Assist

Important safety notes

⚠ WARNING

Adaptive Highbeam Assist does not recognise road users:

- who have no lights, e.g. pedestrians
- who have poor lighting, e.g. cyclists
- whose lighting is blocked, e.g. by a barrier

In very rare cases, Adaptive Highbeam Assist recognises road users too late or not at all. In this, or in similar situations, the automatic main-beam headlamps will not be deactivated or activated regardless. There is a risk of an accident.

Always carefully observe the traffic conditions and switch off the main-beam headlamps in good time.



You can use this function to set the headlamps to change between dipped beam and main beam automatically. The system recognises vehicles with their lights on, either approaching from the opposite direction or travelling in front of your vehicle, and consequently switches the headlamps from main beam to dipped beam.

The system automatically adapts the dipped-beam headlamp range depending on the distance to the other vehicle. Once the system no longer detects any other vehicles, it reactivates the main-beam headlamps.

The system's optical sensor is located behind the windscreen near the overhead control panel.

Switching Adaptive Highbeam Assist on and off

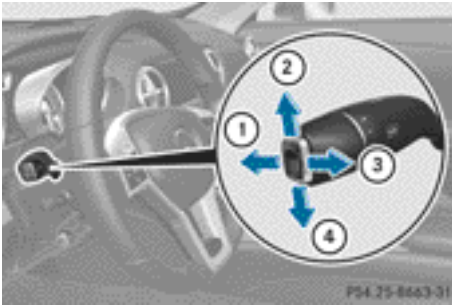

- ① Main-beam headlamps
- ② Turn signal, right
- ③ Headlamp flasher
- ④ Turn signal, left

► **To activate:** activate the Adaptive Highbeam Assist function using the on-board computer (▷ page 235).

► Turn the light switch to **AUTO**.

► Press the combination switch beyond the pressure point in the direction of arrow ① (▷ page 129).

The  indicator lamp in the multifunction display lights up if it is dark and the light sensor activates the dipped-beam headlamps.



If you are driving at speeds above 45 km/h:

the headlamp range is set automatically depending on the distance between the vehicle and other road users.

If you are driving at speeds above 55 km/h and no other road users are recognised:

the main-beam headlamps are switched on automatically. The  indicator lamp in the instrument cluster also lights up.

If you are driving at speeds below 45 km/h or other road users are recognised or the roads are adequately lit:

the main-beam headlamps are switched off automatically. The  indicator lamp in the instrument cluster goes out. The 

indicator lamp in the multifunction display remains lit.

► **To deactivate:** move the combination switch back to its normal position.

The  indicator lamp in the instrument cluster goes out.

Headlamps misted up on the inside

The headlamps may mist up on the inside if there is high atmospheric humidity.

► Switch on the lights and drive off.

The level of moisture diminishes, depending on the length of the journey and the weather conditions (humidity and temperature).

If the level of moisture does not diminish:



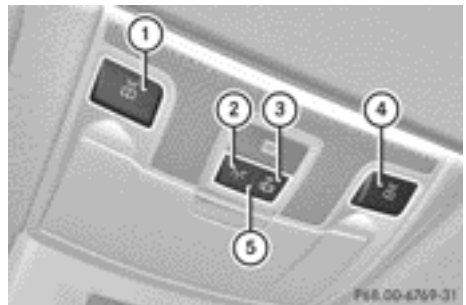

► Have the headlamps checked at a qualified specialist workshop.

Interior lighting

Overview of interior lighting



Overhead control panel

- ①  Switches the left-hand reading lamp on/off
- ②  Switches the interior lighting on
- ③  Switches the interior lighting/automatic interior lighting control off
- ④  Switches the right-hand reading lamp on/off
- ⑤ To switch the automatic interior lighting control on

Interior lighting control

General notes

In order to prevent the vehicle's battery from discharging, the interior lighting functions are automatically deactivated after some time except for when the key is in position **2** in the ignition lock.

Automatic interior lighting control

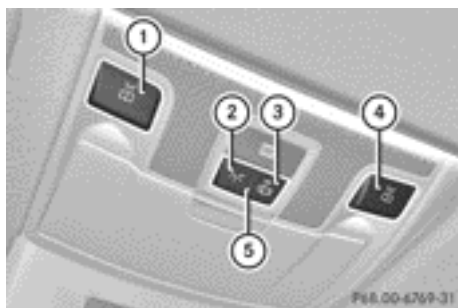

Overhead control panel

- ① To switch the left-hand reading lamp on/off
- ② To switch the interior lighting on
- ③ To switch the interior lighting/automatic interior lighting control off
- ④ To switch the right-hand reading lamp on/off
- ⑤ To switch the automatic interior lighting control on

► **To switch on:** set the switch to centre position ⑤.

► **To switch off:** set the switch to the position.

The interior lighting automatically switches on if you:

- unlock the vehicle
- open a door
- remove the key from the ignition lock

The interior lighting is activated for a short time when the key is removed from the ignition lock. You can activate this delayed

switch-off using the on-board computer (► page 236).

Manual interior lighting control

► **To switch the interior lighting on:** set the switch to the position.

► **To switch the interior lighting off:** set the switch to the or (if the door is closed) to the centre position.

► **To switch the reading lamps on/off:** press the button.

Crash-responsive emergency lighting

The interior lighting is activated automatically if the vehicle is involved in an accident.

► **To switch off the crash-responsive emergency lighting:** press the hazard warning lamp button.

or

► Lock and then unlock the vehicle using the key.

Replacing bulbs

DANGER

Xenon bulbs are under high voltage. You can get an electric shock if you remove the cover of the xenon bulb and touch the electrical contacts. There is a risk of fatal injury.

Never touch the parts or the electrical contacts of the xenon bulb. Always have work on the xenon bulbs carried out at a qualified specialist workshop.

The front and rear lamps of your vehicle are equipped with either xenon or LED bulbs. Do not replace the bulbs yourself. Contact a qualified specialist workshop which has the necessary specialist knowledge and tools to carry out the work required.

Bulbs and lamps are an important aspect of vehicle safety. You must therefore make sure

that these function correctly at all times. Have the headlamp setting checked regularly.

Windscreen wipers

Switching the windscreen wipers on/off

! Do not operate the windscreen wipers when the windscreen is dry, as this could damage the wiper blades. Moreover, dust that has collected on the windscreen can scratch the glass if wiping takes place when the windscreen is dry.

If it is necessary to switch on the windscreen wipers in dry weather conditions, always operate them using washer fluid.

! If the windscreen wipers leave smears on the windscreen after the vehicle has been washed in an automatic car wash, this may be due to wax or other residue. Clean the windscreen with washer fluid after an automatic car wash.

! Intermittent wiping with rain sensor: due to optical influences and the windscreen becoming dirty in dry weather conditions, the windscreen wipers may be activated inadvertently. This could damage the windscreen wiper blades or scratch the windscreen.

For this reason, you should always switch off the windscreen wipers in dry weather.

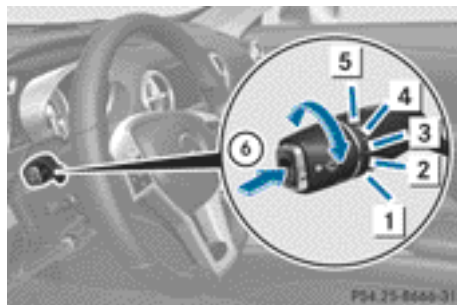

Combination switch

- 1 Windscreen wipers off
- 2 Intermittent wipe, low (rain sensor set to low sensitivity)
- 3 Intermittent wipe, high (rain sensor set to high sensitivity)
- 4 Continuous wipe, slow
- 5 Continuous wipe, fast
- 6 Single wipe / to wipe the windscreen using washer fluid

► Turn the key to position **1** or **2** in the ignition lock.

► Turn the combination switch to the corresponding position.

In the or position, the appropriate wiping frequency is set automatically according to the intensity of the rain. In the position, the rain sensor is more sensitive than in the position, causing the windscreen wipers to wipe more frequently.

If the wiper blades are worn, the windscreen will no longer be wiped properly. This could prevent you from observing the traffic conditions, thereby causing an accident. Replace the wiper blades twice a year, ideally in spring and autumn.

i The vehicle is equipped with the MAGIC VISION CONTROL wipe/wash system. The washer fluid is fed through the wiper blades and when wiping the screen with washer fluid , the water is emitted directly from the blades.

Replacing the wiper blades

Important safety notes

WARNING

If the windscreen wipers begin to move while you are changing the wiper blades, you can be trapped by the wiper arm. There is a risk of injury.

Always switch off the windscreen wipers and ignition before changing the wiper blades.

! To avoid damaging the windscreen wiper blades, make sure that you touch only the wiper arm of the windscreen wiper.

! Never open the bonnet if a windscreen wiper arm has been folded away from the windscreen.

Never fold a windscreen wiper arm without a wiper blade back onto the windscreen.

Hold the windscreen wiper arm firmly when you change the wiper blade. If you release the windscreen wiper arm without a wiper blade and it falls onto the windscreen, the windscreen may be damaged by the force of the impact.

Mercedes-Benz recommends that you have the wiper blades changed at a qualified specialist workshop.

! Always position the windscreen wiper arms vertically before folding them away from the windscreen. By doing so, you will avoid damage to the bonnet.

Replacing the windscreen wiper blades

Moving the wiper blades to a vertical position

On vehicles without KEYLESS-GO:

- ▶ Turn the key to position **1** or **2** in the ignition lock.
- ▶ Set the windscreen wipers to position .



- ▶ When the wiper arms have reached a vertical position, turn the key to position **0** and remove it from the ignition lock.
- ▶ Fold the wiper arm away from the windscreen until it engages.

On vehicles with KEYLESS-GO:

- ▶ Switch off the engine.
- ▶ Remove your foot from the brake pedal.
- ▶ Set the windscreen wipers to position .
- ▶ Press the Start/Stop button repeatedly until the windscreen wipers start.
- ▶ When the wiper arms have reached a vertical position, press the Start/Stop button.
- ▶ Fold the wiper arm away from the windscreen until it engages.

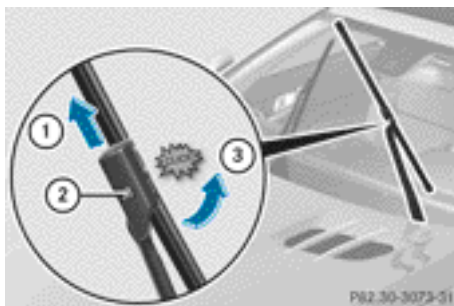
Removing the wiper blades



- ▶ **To bring the wiper blade into position to be removed:** hold the wiper arm firmly with one hand. With the other hand, turn the wiper blade in the direction of arrow  beyond the point of resistance. The wiper blade engages in the removal position with an audible click.
- ▶ **To remove a wiper blade:** firmly press release knob  and pull the wiper blade upwards .

Fitting the wiper blades

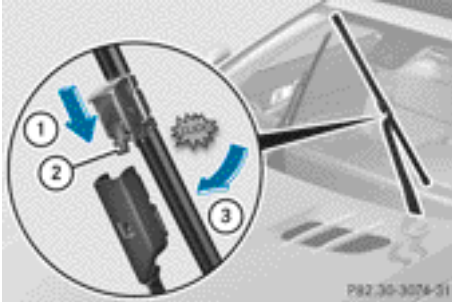

- ▶ Push the new wiper blade in the direction of arrow ① onto the wiper arm until tab ② engages.
- ▶ Push the wiper blade out of the removal position in the direction of arrow ③ beyond the point of resistance.
The wiper blade disengages with an audible click and is freely movable again.
- ▶ Make sure that wiper blade is seated correctly.
- ▶ Fold the wiper arm back onto the windscreen.

Problems with the windscreen wipers

Problem	Possible causes/consequences and ► Solutions
The windscreen wipers are jammed.	<p>Leaves or snow, for example, may be obstructing the windscreen wiper movement. The wiper motor has been deactivated.</p> <ul style="list-style-type: none"> ► For safety reasons, you should remove the key from the ignition lock. <p>or</p> <ul style="list-style-type: none"> ► Switch off the engine using the Start/Stop button and open the driver's door. ► Remove the cause of the obstruction. ► Switch the windscreen wipers back on.
The windscreen wipers fail completely.	<p>The windscreen wiper drive is malfunctioning.</p> <ul style="list-style-type: none"> ► Select another wiper speed on the combination switch. ► Have the windscreen wipers checked at a qualified specialist workshop.

Useful information	140
Overview of climate control systems	140
Operating the climate control system	142
Adjusting the air vents	148

Useful information

- i** This Owner's Manual describes all models, series and optional equipment for your vehicle that were available at the time of going to press. National variations are possible. Note that your vehicle may not be equipped with all of the functions described. This is also the case for systems and functions relevant to safety.
- i** Read the information on qualified specialist workshops: (▷ page 38).

Overview of climate control systems

Important safety notes

 **WARNING**

Observe the settings recommended on the following pages. The windows could otherwise mist up. This may prevent you from observing the traffic conditions, thereby causing an accident.

Climate control regulates the temperature and the humidity in the vehicle interior and filters undesirable substances out of the air. Climate control is only operational when the engine is running. The system only works optimally if the side windows and the roof are closed.

The residual heat function can only be activated or deactivated with the ignition switched off (▷ page 148).

- i** Ventilate the vehicle for a brief period during warm weather. This will speed up the cooling process and the desired vehicle interior temperature will be reached more quickly.
- i** It is possible that the residual heat function may be activated automatically an hour after the key has been removed in order to dry the air-conditioning system. The vehicle is then ventilated for 30 minutes to dry the air-conditioning system.

Control panel for THERMOTRONIC automatic climate control (2-zone)

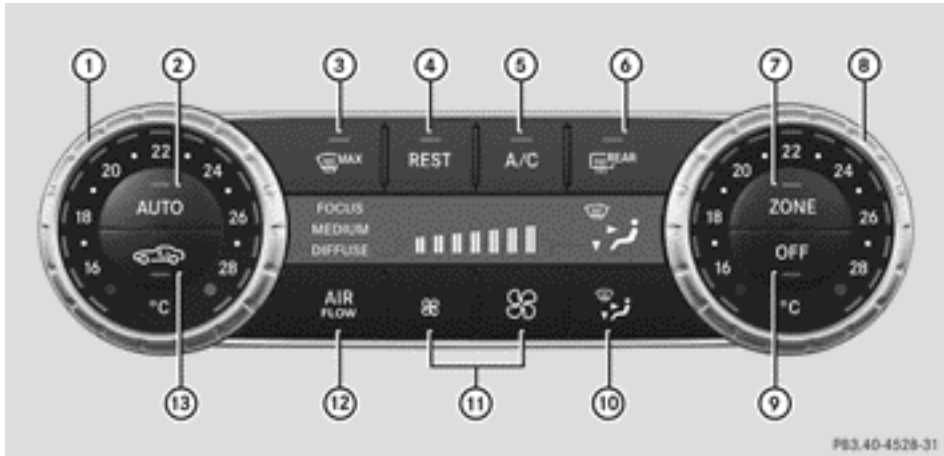

- ① Sets the temperature, left (▷ page 144)
- ② Sets climate control to automatic mode (▷ page 143)
- ③ Demists the windscreen (▷ page 145)
- ④ Activates/deactivates the residual heat function (▷ page 148)
- ⑤ Activates/deactivates cooling with air dehumidification (▷ page 142)
- ⑥ Switches the rear window heating on/off (▷ page 146)
- ⑦ Switches the ZONE function on/off (▷ page 145)
- ⑧ Sets the temperature, right (▷ page 144)
- ⑨ Switches climate control on/off (▷ page 142)
- ⑩ Sets the air distribution (▷ page 144)
- ⑪ Sets the airflow (▷ page 145)
- ⑫ Sets the climate mode (▷ page 143)
- ⑬ Activates/deactivates air-recirculation mode (▷ page 146)

Information about using THERMOTRONIC automatic climate control

The following contains instructions and recommendations to enable you to get the most out of your THERMOTRONIC automatic climate control.

- Activate climate control using the **AUTO** and **A/C** buttons or the **A/C REST** button on the control panel for the climate control. The indicator lamps in the **AUTO** and **A/C** buttons or the **A/C REST** button light up.
- In automatic mode, you can also use the **AIR FLOW** button on the control panel for the climate control to set a climate mode (FOCUS/MEDIUM/DIFFUSE). The MEDIUM level is recommended.
- Set the temperature to 22 °C.
- Only use the demisting function briefly until the windscreen is clear again.
- Only use the air-recirculation mode briefly, e.g. if there are unpleasant outside odours

or when in a tunnel. The windows could otherwise mist up as no fresh air is drawn into the vehicle in air-recirculation mode.

- Use the ZONE function to adopt the temperature settings on the driver's side for the front-passenger side as well. The indicator lamp in the **ZONE** button goes out.
 - Use the residual heat function if you want to heat or ventilate the vehicle interior when the ignition is switched off. The residual heat function can only be activated or deactivated with the ignition switched off.
- i** During automatic engine switch-off, the ECO start-stop function only operates at a reduced capacity. If you require full climate control capacity, the ECO start/stop function can be deactivated by pressing the ECO button (▷ page 158).

Operating the climate control system

Switching climate control on/off

General notes

- i** If climate control is switched off, the air supply and air circulation are also switched off. Only use this setting for a brief period. The windows could otherwise mist up.
- i** Switch on climate control primarily using the **AUTO** button (▷ page 143).

Switching on/off

- ▶ Turn the key to position **2** in the ignition lock.
 - ▶ **To switch on:** press the **AUTO** button on the control panel for the climate control. The indicator lamp in the **AUTO** button lights up. Airflow and air distribution are set to automatic mode.
- or
- ▶ Press the **OFF** button on the control panel for the climate control. The indicator lamp in the **OFF** button goes out. The previous settings are reactivated.
 - ▶ **To switch off:** press the **OFF** button. The indicator lamp in the **OFF** button lights up.

Activating/deactivating the cooling with air dehumidification function

General notes

WARNING

If the "cooling with air dehumidification" function is deactivated, the air inside the vehicle will not be cooled (during warm weather) or dehumidified. The windows could mist up more quickly. This may prevent you from observing the traffic conditions, thereby causing an accident.

The cooling with air dehumidification function is only available when the engine is running. The air inside the vehicle is cooled and dehumidified according to the temperature selected.





Condensation may drip from the underside of the vehicle when cooling mode is active. This is normal and not a sign that there is a malfunction.

- i** The refrigerant that is used by the cooling with air dehumidification does not contain chlorofluorocarbons and therefore does not damage the ozone layer.



Switching on/off



 button (example)

- ▶ **To activate:** press the  button. The indicator lamp in the  button lights up.
- ▶ **To deactivate:** press the  or  button. The indicator lamp in the  button goes out. The cooling with air dehumidification function has a delayed switch-off feature.

Problems with the cooling with air dehumidification function

When you press the  or  button, the indicator lamp in the button flashes three times or remains off. You can no longer switch on the cooling with air dehumidification function.



- ▶ Visit a qualified specialist workshop.

Setting climate control to automatic mode





In automatic mode, the set temperature is maintained automatically at a constant level. The system automatically regulates the temperature of the dispensed air, the airflow and the air distribution.

Automatic mode will achieve optimal operation if cooling with air dehumidification is also activated. If desired, cooling with air dehumidification can be deactivated.

- ▶ Turn the key to position **2** in the ignition lock.
- ▶ Set the desired temperature.
- ▶ **To activate:** press the  button. The indicator lamp in the  button lights up. Automatic air distribution and airflow are activated.
- ▶ **To select manually:** press the  button.

or

- ▶ Press the  or  button. The indicator lamp in the  button goes out.

Setting the climate mode

In automatic mode you can select the following climate modes:

- FOCUS high airflow that is set slightly cooler
- MEDIUM medium airflow, standard setting
- DIFFUSE low airflow that is set slightly warmer and with less of a draught



button (example)

- ▶ Turn the key to position **2** in the ignition lock.
- ▶ Press the **AUTO** button.
- ▶ Press the button repeatedly until the desired climate mode appears in the display.

Setting the temperature

Switching on/off



Different temperatures can be set for the driver's and front-passenger sides.

- ▶ Turn the key to position **2** in the ignition lock.
- ▶ Turn controls **1** or **8** clockwise or anti-clockwise.
Turn controls **1** or **8** clockwise or anti-clockwise (▷ page 141).
Only change the temperature setting in small increments. Start at 22 °C.

Setting the air distribution

Switching on/off



- ▶ Turn the key to position **2** in the ignition lock.
- ▶ Press the button repeatedly until the desired symbol appears in the display.

The following air distribution settings can be selected:



- Directs the airflow through the centre and side air vents
- Directs the airflow through the foot-well air vents
- Directs the airflow through the centre and side air vents as well as the foot-well air vents
- Directs the airflow through the demister vents
- Directs the airflow through the demister, centre and side air vents
- Directs the airflow through the foot-well and demister vents
- Directs the airflow through the demister vents, the centre and side air vents as well as the footwell air vents.

i Regardless of the air distribution setting, airflow is always directed through the side air vents. The side air vents can only be closed when the controls on the side air vents are turned downwards.

Setting the airflow





Switching on/off



- ▶ Turn the key to position **2** in the ignition lock.
- ▶ **To increase:** press the  button.
- ▶ **To reduce:** press the  button.

Switching the ZONE function on/off





- ▶ **To switch on:** press the  button.
The indicator lamp in the  button lights up. The temperature setting for the driver's side is not adopted for the front-passenger side.
- ▶ **To switch off:** press button .
The indicator lamp in the  button goes out. The temperature setting for the driver's side is adopted for the front-passenger side.



Demisting the windscreen



 button (example)

You can use this function to demist the windscreen or to demist the inside of the windscreen and the side windows. Switch off the "demisting" function as soon as the windscreen is clear again.

- ▶ Turn the key to position **2** in the ignition lock.
- ▶ **To activate:** press the  button.
The indicator lamp in the  button lights up.
The climate control system switches to the following functions:
 - high airflow
 - high temperature
 - air distribution to the windscreen and front side windows
 - air-recirculation mode off

▶ **To deactivate:** press the  button.
The indicator lamp in the  button goes out. The previous settings are reactivated. Air-recirculation mode remains deactivated.

or

▶ Press the **AUTO** button.
The indicator lamp in the  button goes out. Airflow and air distribution are set to automatic mode.

or

▶ Turn the temperature controls to the left or to the right on the control panel for the cli-

mate control or clockwise or anti-clockwise.



Turn temperature controls ① or ⑧ clockwise or anti-clockwise (▷ page 141).

or



- ▶ Press the  or  button.

Demisting the windows

Windows misted up on the inside

- ▶ Activate the cooling with air dehumidification function .
- ▶ Activate automatic mode .
- ▶ If the windows continue to mist up, activate the demisting function (▷ page 145).
- i** You should only select this setting until the windscreen is clear again.

Windows misted up on the outside

- ▶ Activate the windscreen wipers.
- ▶ Press the  button repeatedly until the  or  symbol appears in the display.
- i** You should only select this setting until the windscreen is clear again.

Rear window heating

Switching on/off



WARNING

Clear all windows of ice or snow before setting off. Otherwise, impaired visibility could endanger you and others.



The rear window heating has a high current draw. You should therefore switch it off as soon as the window is clear. It otherwise switches off automatically after several minutes.

If the battery voltage is too low, the rear window heating may switch off.

- ▶ Turn the key to position **2** in the ignition lock.
- ▶ Press the  button.
The indicator lamp in the  button lights up or goes out.

Problems with the rear window heating

The rear window heating has switched off prematurely or cannot be activated.





- ▶ Switch off any consumers that are not required, e.g. reading lamps or interior lighting.
When the battery is sufficiently charged, the rear window heating is activated again automatically.

Activating/deactivating air-recirculation mode

WARNING

Only switch over to air-recirculation mode briefly at low outside temperatures. Otherwise, the windows could mist up, thus impairing visibility and endangering yourself and others. This may prevent you from observing the traffic conditions, thereby causing an accident.



- ▶ Turn the key to position **2** in the ignition lock.
- ▶ **To activate:** press the  button. The indicator lamp in the  button lights up.
 - i** Air-recirculation mode is automatically activated at high levels of pollution or at high outside temperatures. When air-recirculation mode is activated automatically, the indicator lamp in the  button is not lit. Outside air is added after about 30 minutes.
- ▶ **To deactivate:** press the  button. The indicator lamp in the  button goes out.
 - i** Air-recirculation mode deactivates automatically:
 - after approximately five minutes at outside temperatures below about 5 °C
 - after approximately five minutes if cooling with air dehumidification is deactivated
 - after approximately 30 minutes at outside temperatures above approximately 5 °C and when the "Cooling with air dehumidification" function is active





Convenience opening/closing using the air-recirculation button

WARNING

Make sure that nobody can become trapped between the side window and the door frame

as the side windows are opened and closed. Make sure that all objects and body parts are clear of the side windows when they are being opened or closed. You or the objects could be drawn in or become trapped between the side window and the door frame as the window moves. If there is a risk of entrapment, operate the  switch to move the side window in the opposite direction.



- ▶ **Convenience closing feature:** press and hold the  button until the side windows are closed. The indicator lamp in the  button lights up. Air-recirculation mode is activated.
- ▶ **Convenience opening feature:** press and hold the  button until the side windows are opened. The side windows move back to their original positions. The indicator lamp in the  button goes out. Air-recirculation mode is deactivated.
 - i** If you open the side windows manually after closing them with the convenience closing feature, they will remain in this position when opened using the convenience opening feature.

Activating/deactivating the residual heat function



It is possible to make use of the residual heat of the engine to continue heating the stationary vehicle for up to 30 minutes after the engine has been switched off. The heating time depends on the temperature that has been set for the vehicle interior.

- ▶ Turn the key to position **0** in the ignition lock or remove it.
- ▶ **To activate:** press the **REST** button. The indicator lamp in the **REST** button lights up.
- ❗ The blower will run at a low speed regardless of the airflow setting.
- ❗ If you activate the residual heat function at high temperatures, only the ventilation will be activated. The blower runs at medium speed.
- ▶ **To deactivate:** press the **REST** button. The indicator lamp in the **REST** button goes out.

Residual heat is deactivated automatically:

- after approximately 30 minutes
- when the ignition is switched on
- if the battery voltage drops
- when the auxiliary heating is switched on

Adjusting the air vents

Important safety notes

WARNING

Very hot or very cold air can flow from the air vents. This could cause burns or frostbite to bare skin in the immediate vicinity of the vents. Keep bare skin away from these air outlets. If necessary, direct the airflow away to a different area of the vehicle interior.

In order to ensure the direct flow of fresh air through the air vents into the vehicle interior, please observe the following notes:

- keep the air inlet grille on the bonnet and in the engine compartment on the front-passenger side free of blockages, such as ice, snow or leaves.
- never cover the vents or ventilation grilles in the vehicle interior.
- ❗ You can move the adjusters for the air vents vertically or horizontally, to set the direction of the airflow.
- ❗ Optimal climate control function is achieved by opening the air vents fully and setting the adjusters to the middle position.

Setting the centre air vents

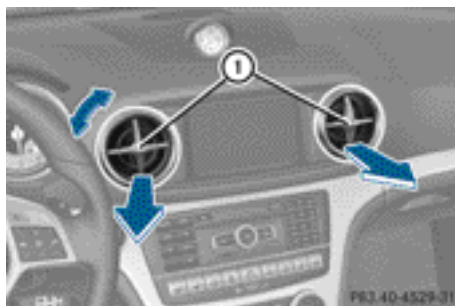

- ▶ **To open the centre air vent:** turn the adjuster in one of centre air vents ① anti-clockwise.
- ▶ **To close the centre air vent:** turn the adjuster in one of centre air vents ① clockwise until it engages.

Setting the side air vents

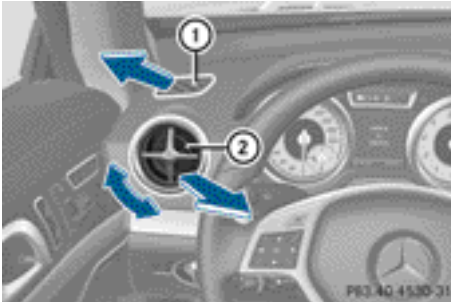

- ① Side window demister vent
- ② Side air vent

- ▶ **To open a side air vent:** turn the adjuster in side air vent ② anti-clockwise.
- ▶ **To close a side air vent:** turn the adjuster in side air vent ② clockwise until it engages.

Setting the glove compartment air vent

- ❗ Close the air vent when heating the vehicle.

At high outside temperatures, open the air vent and activate the "cooling with air dehumidification" function. Otherwise, temperature-sensitive items stored in the glove compartment could be damaged.

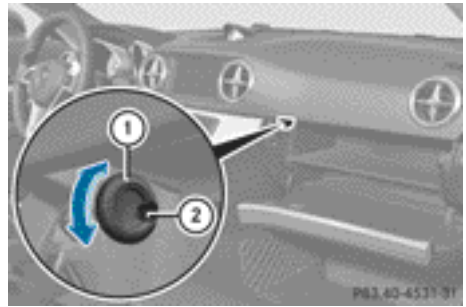

- ① Air vent thumbwheel
- ② Air vent

When automatic climate control is activated, the glove compartment can be ventilated, for instance to cool its contents. The level of airflow depends on the airflow and air distribution settings.

- ▶ **To open/close:** turn thumbwheel ① clockwise or anti-clockwise.

Setting the AIRSCARF vents

⚠ WARNING

Very hot air can flow out of the AIRSCARF vents in the head restraints when AIRSCARF is in operation. This can cause burns on unprotected skin near the AIRSCARF vents. Lower the heating output in good time, when necessary.



You can adjust the blower output of AIRSCARF vents ① using the AIRSCARF button (▶ page 117).

Useful information	152
Running-in notes	152
Driving	152
Automatic transmission	161
Refuelling	170
Parking	172
Driving tips	175
Driving systems	178

Useful information

- i** This Owner's Manual describes all models, series and optional equipment for your vehicle that were available at the time of going to press. National variations are possible. Note that your vehicle may not be equipped with all of the functions described. This is also the case for systems and functions relevant to safety.
- i** Read the information on qualified specialist workshops: (▷ page 38).

Running-in notes

Important safety notes

New or replaced brake pads/linings and discs only reach their optimum braking effect after several hundred kilometres of driving. Compensate for the reduced braking effect by applying greater force to the brake pedal.

The first 1,500 km

If you treat the engine with sufficient care from the very start, you will be rewarded with excellent performance for the remainder of the engine's life.

- Drive at varying vehicle speeds and engine speeds for the first 1,500 km.
- Avoid overstraining the vehicle during this period, e.g. driving at full throttle.
- Change gear in good time, before the rev counter needle is $\frac{2}{3}$ of the way to the red area of the rev counter.
- Do not shift down a gear manually in order to brake.
- Try to avoid depressing the accelerator pedal beyond the point of resistance (kick-down).
- The shift ranges **3**, **2** or **1** should only be engaged when driving slowly, e.g. when driving in mountainous terrain.

After 1,500 km, you may gradually bring the vehicle up to full road and engine speeds.

Additional running-in notes for AMG vehicles:

- Do not drive at speeds above 140 km/h for the first 1,500 km.
 - Only allow the engine to reach a maximum engine speed of 4,500 rpm briefly.
 - It is advisable to select drive program **C** for Controlled Efficiency.
- i** You should also observe these notes on running in if the engine or parts of the drive train on your vehicle have been replaced.

AMG vehicles with self-locking rear axle differential

Your vehicle is equipped with a self-locking differential on the rear axle. Change the oil after a running-in period of 3,000 km to improve protection of the rear axle differential. This oil change prolongs the service life of the differential. Have the oil change carried out at a qualified specialist workshop.

Driving

Important safety notes

WARNING

Objects in the driver's footwell can restrict the pedal travel or obstruct a depressed pedal. The operating and road safety of the vehicle is jeopardised. There is a risk of an accident.

Make sure that all objects in the vehicle are stowed correctly, and that they cannot enter the driver's footwell. Fit the floor mats securely and as specified in order to ensure sufficient clearance for the pedals. Do not use loose floor mats.

⚠ WARNING

Unsuitable footwear can hinder correct usage of the pedals, e.g.:

- shoes with thick soles
- shoes with high heels
- slippers

There is a risk of an accident.

Wear suitable footwear to ensure correct usage of the pedals.

⚠ WARNING

If you switch off the ignition while driving, safety-relevant functions are only available with limitations, or not at all. This could affect, for example, the power steering and the brake boosting effect. You will require considerably more effort to steer and brake. There is a risk of an accident.

Do not switch off the ignition while driving.

⚠ WARNING

If the parking brake has not been fully released when driving, the parking brake can:

- overheat and cause a fire
- lose its hold function.

There is a risk of fire and an accident. Release the parking brake fully before driving off.

! Warm up the engine quickly. Do not use the engine's full performance until it has reached operating temperature.

Only set the automatic transmission to the respective drive positions when the vehicle is stationary.

Where possible, avoid spinning the drive wheels when pulling away on slippery roads. Otherwise, you could damage the drive train.

! **AMG vehicles:** at low engine oil temperatures (below +20 °C), the maximum engine speed is restricted in order to protect the engine. To protect the engine and maintain smooth engine operation, avoid

driving at full throttle when the engine is cold.

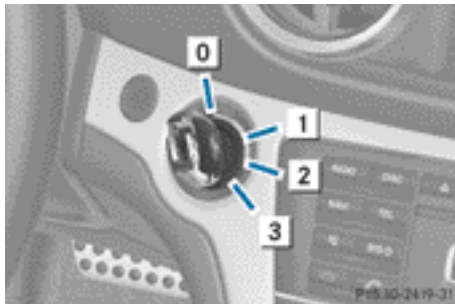
Key positions**Key**

- 0** To remove the key
- 1** Power supply for some consumers, such as the windscreen wipers
- 2** Ignition (power supply for all consumers) and drive position
- 3** To start the engine

i If the key does not belong to the vehicle, it can still be turned in the ignition lock. However, the ignition will not be switched on. The engine cannot be started.

KEYLESS-GO**General notes**

Vehicles with KEYLESS-GO are equipped with a key featuring an integrated KEYLESS-GO start function and a detachable Start/Stop button.

You can switch the engine on and off with the Start/Stop button. The Start/Stop button must be inserted in the ignition lock and the key must be in the vehicle.

Pressing the Start/Stop button several times in succession corresponds to the different key positions in the ignition lock. This is only the case if you are not depressing the brake pedal.

If you depress the brake pedal and press the Start/Stop button, the engine starts immediately.

The Start/Stop button can be removed from the ignition lock. The key can then be inserted into the ignition lock.

i You do not have to remove the Start/Stop button from the ignition lock when you leave the vehicle. You should, however, always take the key with you when leaving the vehicle. As long as the key is in the vehicle:

- the vehicle can be started using the Start/Stop button and
- electrically powered equipment can be operated

i The engine can be switched off while the vehicle is in motion by pressing and holding the Start/Stop button for three seconds. This function operates independently of the ECO start/stop automatic engine switch-off function.

Key positions with KEYLESS-GO



► Insert Start/Stop button ① into ignition lock ②.

i When you insert Start/Stop button ① into ignition lock ②, the system needs approximately two seconds recognition time. You can then use Start/Stop button ①.

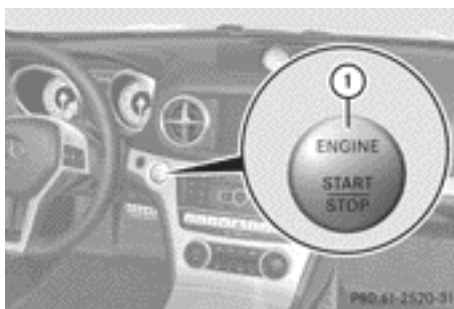

Switching on the power supply

► If Start/Stop button ① has not yet been pressed, this corresponds to the key being removed from the ignition.

► Press Start/Stop button ① once.

The power supply is switched on. You can now activate the windscreen wipers, for example.

i The power supply is switched off if you press Start/Stop button ① twice when in this position and the driver's door is open.

Switching on the ignition

► Press Start/Stop button ① twice.
The ignition is switched on.

i The power supply is switched off if you press Start/Stop button ① twice when in this position and the driver's door is open.

When you switch on the ignition, all of the indicator lamps in the instrument cluster light up. If an indicator lamp does not go out after starting the engine or lights up while driving, there may be a technical problem

(▷ page 271).

Removing the Start/Stop button

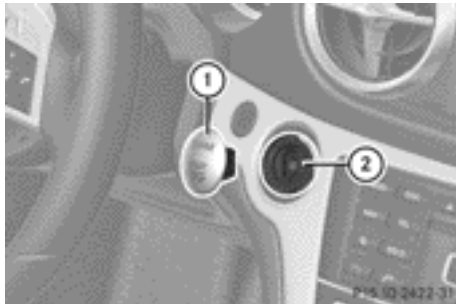

You can remove the Start/Stop button from the ignition lock and start the vehicle as normal using the key.

- ▶ Remove Start/Stop button ① from ignition lock ②.

i You do not have to remove the Start/Stop button from the ignition lock when you leave the vehicle.

Starting the engine

Important safety notes

⚠ WARNING

If children are left unsupervised in the vehicle, they could:

- open the doors, thus endangering other people or road users.
- get out and disrupt traffic.
- operate the vehicle's equipment.

Additionally, children could set the vehicle in motion if, for example, they:

- release the parking brake.
- shift the automatic transmission out of parking position P.
- start the engine.

There is a risk of an accident and injury.

When leaving the vehicle, always take the key with you and lock the vehicle. Never leave children or animals unattended in the vehicle. Always keep the key out of reach of children.

⚠ WARNING

Combustion engines emit poisonous exhaust gases such as carbon monoxide. Inhaling these exhaust gases leads to poisoning. There is a risk of fatal injury. Therefore never leave the engine running in enclosed spaces without sufficient ventilation.

- !** Do not depress the accelerator pedal when starting the engine.

i **Vehicles with a petrol engine:** the catalytic converter is preheated for up to 30 seconds after a cold start. The sound of the engine may change during this time.

Starting procedure with the key

- ▶ Depress the brake pedal and keep it depressed.
- ▶ Shift the transmission to position **P**. The transmission position display in the multifunction display shows **P**.
- i** You can also start the engine when the transmission is in position **N**.
- ▶ Turn the key to position **3** in the ignition lock (> page 153) and release it as soon as the engine is running.

Using KEYLESS-GO to start the engine

The Start/Stop button can be used to start the vehicle without inserting the key into the ignition lock. The key must be in the vehicle and the Start/Stop button must be inserted in the ignition lock.

- ▶ Depress the brake pedal and keep it depressed.
- ▶ Shift the transmission to position **P**. The transmission position display in the multifunction display shows **P**.

- i** You can also start the engine when the transmission is in position **N**.
- ▶ Press the Start/Stop button once (▷ page 153). Press the Start/Stop button once.
The engine starts.

Pulling away

Automatic transmission

WARNING

If the engine speed is above the idling speed and you engage transmission position **D** or **R**, the vehicle could pull away suddenly. There is a risk of an accident.

When engaging transmission position **D** or **R**, always firmly depress the brake pedal and do not simultaneously accelerate.

- i** It is only possible to shift the transmission from position **P** to the desired position if you depress the brake pedal. Only then is the shift lock released.
- ▶ Depress the brake pedal and keep it depressed.
- ▶ Shift the transmission to position **D** or **R**.
- ▶ Release the electric parking brake (▷ page 173).
- ▶ Release the brake pedal.
- ▶ Carefully depress the accelerator pedal.

- i** The vehicle locks centrally once you have pulled away. The locking knobs in the doors drop down.

You can open the doors from the inside at any time.

You can also deactivate the automatic locking feature (▷ page 236).

- i** Upshifts take place at higher engine speeds after a cold start. This helps the catalytic converter to reach its operating temperature more quickly.

Hill start assist

WARNING

After a short time, hill start assist will no longer brake your vehicle and it could roll away. There is a risk of an accident and injury.

Therefore, quickly move your foot from the brake pedal to the accelerator pedal. Never leave the vehicle when it is held by hill start assist.

Hill start assist helps you when pulling away forwards or in reverse on an uphill gradient. It holds the vehicle for a short time after you have removed your foot from the brake pedal. This gives you enough time to move your foot from the brake pedal to the accelerator pedal and depress it before the vehicle begins to roll.

- ▶ Remove your foot from the brake pedal.
The vehicle is then held for about a second.
- ▶ Pull away.

Hill start assist will not function if:

- you are pulling away on a level road or a downhill gradient.
- the transmission is in position **N**.
- the parking brake is applied.
- ESP[®] is malfunctioning.

ECO start/stop function

Important safety notes

WARNING

If the engine is switched off automatically and you exit the vehicle, the engine is restarted automatically. The vehicle may begin moving. There is a risk of accident and injury.

If you wish to exit the vehicle, always turn off the ignition and secure the vehicle against rolling away.

General notes



① ECO start/stop display

If the **ECO** symbol is shown in green in the multifunction display, the ECO start/stop function switches the engine off automatically if the vehicle stops moving.

When pulling away again, the engine starts automatically. The ECO start/stop function thereby helps you to reduce the fuel consumption and emissions of your vehicle.

Every time you switch on the engine using the key or the Start/Stop button, the ECO start/stop function is activated.

If the ECO start/stop function has been manually deactivated (▷ page 158) or a malfunction has caused the system to be deactivated, the **ECO** symbol is not displayed.

AMG vehicles: the **Stop/Start active** or **Stop/Start inactive** message in the AMG menu in the multifunction display goes out.

AMG vehicles: the ECO start/stop function is only available in drive program **C**.

i AMG vehicles: if automatic cylinder shut-off is active in drive program **C**, the number of active cylinders **4** is also shown in the **ECO** symbol. This means that the engine is operating with four cylinders.

If cylinder shut-off is not active, the engine is operating with all eight cylinders. In this case, the number of active cylinders **8** is shown in the **ECO** symbol.

For further information on automatic engine switch-off (▷ page 157) and automatic engine start (▷ page 158).

Automatic engine switch-off

If the vehicle is braked to a standstill in **D** or **N**, the ECO start/stop function switches off the engine automatically.

The ECO start/stop function is operational and the **ECO** symbol is displayed in green in the multifunction display, if:

- the indicator lamp in the ECO button is lit green
- the outside temperature is within the comfort range
- the engine is at normal operating temperature
- the set temperature for the vehicle interior has been reached
- the battery is sufficiently charged
- the system detects that the windscreen is not misted up when the air-conditioning system is switched on
- the bonnet is closed
- the driver's door is closed and the driver's seat belt is fastened

If not all conditions for automatic engine switch-off are fulfilled, the **ECO** symbol is shown in yellow.

AMG vehicles: the AMG menu in the multifunction display additionally shows the **Stop/Start inactive** message.

i All of the vehicle's systems remain active when the engine is switched off automatically.

i All vehicles (except AMG vehicles): automatic engine switch-off can take place a maximum of four times consecutively (initial stop, then three subsequent stops). The **ECO** symbol is shown in yellow in the multifunction display after the engine has been started automatically for the fourth time. When the **ECO** symbol is shown in green in the multifunction display, automatic engine switch-off is again possible.

- i** **AMG vehicles:** the number of times which the engine can be automatically switched off is unlimited.
- i** The HOLD function can be activated if the engine has been switched off automatically. It is then not necessary to continue applying the brakes during the automatic stop phase. When you depress the accelerator pedal, the engine starts automatically and the braking effect of the HOLD function is deactivated.

Automatic engine start

The engine is started automatically if:

- you switch off the ECO start/stop function by pressing the ECO button
 - in transmission position **D** or **N**, the brake pedal is released and the HOLD function is not active
 - you depress the accelerator pedal
 - you engage reverse gear **R**
 - you move the transmission out of position **P**
 - you switch to drive program **S**, **S+** or **M** (AMG vehicles)
 - you unfasten your seat belt or open the driver's door
 - the vehicle starts to roll
 - the brake system requires this
 - the temperature in the vehicle interior deviates from the set range
 - the system detects moisture on the windscreen when the air-conditioning system is switched on
 - the battery's charge status is too low
- i** Shifting the transmission to position **P** does not start the engine.
 - i** If you shift the transmission from **R** to **D**, the ECO start/stop function is available again once the **ECO** symbol reappears in green in the multifunction display.

Deactivating/activating the ECO start/stop function

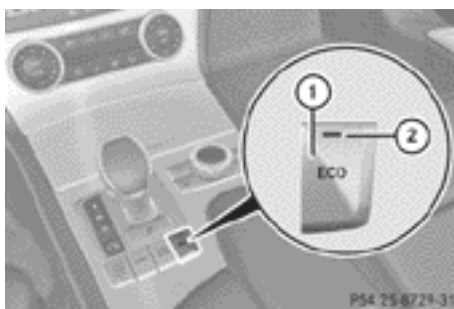

ECO button

Deactivating (except for AMG vehicles)

- ▶ Press button ①.
Indicator lamp ② on button ① and the **ECO** symbol in the multifunction display go out.

Activating (except for AMG vehicles)

- ▶ Press button ①.
Indicator lamp ② on button ① lights up. If all conditions for automatic engine switch-off (▷ page 157) are fulfilled, the **ECO** symbol is shown in green in the multifunction display.
If not all conditions for automatic engine switch-off are fulfilled (▷ page 157), the **ECO** symbol is shown in yellow in the multifunction display. If this is the case, the ECO start/stop function is not available.

- i** If indicator lamp ② on button ① is off, the ECO start/stop function has been deactivated manually or as the result of a malfunction. The engine will then not be switched off automatically when the vehicle stops.



ECO button in AMG vehicles

Deactivating (AMG vehicles)

- ▶ Press button ① in drive program **C**.

or

- ▶ Switch to drive program **S**, **S+** or **M**

(▷ page 165).

Indicator lamp ② on button ① and the **ECO** symbol in the multifunction display go out.

The **Stop/Start active** or **Stop/Start inactive** message in the AMG menu in the multifunction display goes out.

Activating (AMG vehicles)

- ▶ Press button ①.

Indicator lamp ② on button ① lights up.

If drive program **S**, **S+** or **M** is active, the automatic transmission switches to drive program **C**.

If all conditions for automatic engine switch-off (▷ page 157) are fulfilled, the **ECO** symbol is shown in green in the multifunction display. In addition, the **Stop/Start active** message is shown in the AMG menu in the multifunction display.

If not all conditions for automatic engine switch-off (▷ page 157) are fulfilled, the **ECO** symbol is shown in yellow in the multifunction display. If this is the case, the ECO start/stop function is not available. In addition, the **Stop/Start inactive** message is shown in the AMG menu in the multifunction display.

- i** If indicator lamp ② on button ① is off, the ECO start/stop function has been deactivated manually or as the result of a malfunction. The engine will then not be switched off automatically when the vehicle stops.

Problems with the engine	
Problem	Possible causes/consequences and ► Solutions
The engine does not start.	<p>The HOLD function is activated.</p> <ul style="list-style-type: none"> ► Deactivate the HOLD function (▷ page 193). ► Try to start the engine again.
The engine does not start. The starter motor can be heard.	<ul style="list-style-type: none"> • There is a malfunction in the engine electronics. • There is a malfunction in the fuel supply. <p>► Turn the key back to position 0 in the ignition lock before attempting to start the engine again.</p> <p>or</p> <ul style="list-style-type: none"> ► Press the Start/Stop button repeatedly until all indicator lamps in the instrument cluster go out. ► Try to start the engine again (▷ page 155). Avoid excessively long and frequent attempts to start the engine, as this will drain the battery. <p>If the engine does not start after several attempts:</p> <ul style="list-style-type: none"> ► Consult a qualified specialist workshop.
The engine does not start. You cannot hear the starter motor.	<p>The on-board voltage is too low because the battery is too weak or discharged.</p> <ul style="list-style-type: none"> ► Jump-start the vehicle (▷ page 553). <p>If the engine does not start despite attempts to jump-start it:</p> <ul style="list-style-type: none"> ► Consult a qualified specialist workshop. <p>The starter motor was exposed to a thermal load that was too high.</p> <ul style="list-style-type: none"> ► Allow the starter motor to cool down for approximately two minutes. ► Try to start the engine again. <p>If the engine still does not start:</p> <ul style="list-style-type: none"> ► Consult a qualified specialist workshop.
The engine is not running smoothly and is misfiring.	<p>There is a malfunction in the engine electronics or in a mechanical component of the engine management system.</p> <ul style="list-style-type: none"> ► Only depress the accelerator pedal slightly. Otherwise, non-combusted fuel may get into the catalytic converter and damage it. ► Have the cause rectified immediately at a qualified specialist workshop.

Problem	Possible causes/consequences and ► Solutions
<p>The coolant temperature display is showing more than 120 °C. The coolant warning lamp may also be lit and a warning tone may sound.</p>	<p>The coolant level is too low. The coolant is too hot and the engine is no longer being cooled sufficiently.</p> <ul style="list-style-type: none"> ► Stop as soon as possible and allow the engine and the coolant to cool down. ► Check the coolant level (► page 533). Observe the warning notes as you do so and top up the coolant if necessary. <p>If the coolant level is correct, the engine radiator fan may be faulty. The coolant is too hot and the engine is no longer being cooled sufficiently.</p> <ul style="list-style-type: none"> ► If the coolant temperature is below 120 °C, you can continue driving to the nearest qualified specialist workshop. ► Avoid heavy loads on the engine as you do so, e.g. driving in mountainous terrain and stop-start traffic.

Automatic transmission

Important safety notes

WARNING

If the engine speed is above the idling speed and you engage transmission position **D** or **R**, the vehicle could pull away suddenly. There is a risk of an accident.

When engaging transmission position **D** or **R**, always firmly depress the brake pedal and do not simultaneously accelerate.

Selector lever

Overview of transmission positions



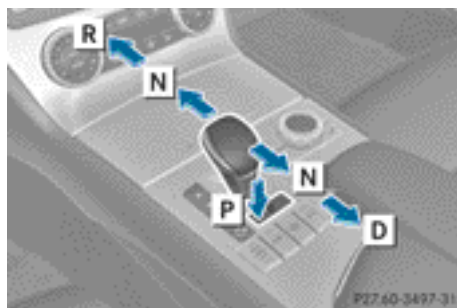

! If the engine speed is too high or if the vehicle is rolling, do not shift the transmission directly from **D** to **R**, from **R** to **D** or directly to **P**.

Do not open the driver's door while the vehicle is in motion. At low speeds in transmission position **D** or **R**, park position **P** is otherwise engaged automatically.

The transmission could be damaged.



Selector lever

-  Park position
-  Reverse gear
-  Neutral
-  Drive

When you select a transmission position, the selector lever subsequently returns to its original position.

The current transmission position **P**, **R**, **N** or **D** appears in the transmission position display in the multifunction display.

Engaging park position P

- When the vehicle is stationary, depress the brake pedal.
- Press the **P** button in the centre console.

- i** Park position **P** is disengaged if you:
 - depress the brake pedal and
 - push the selector lever forwards or back to the first point of resistance.

The transmission shifts to neutral **N**.

Park position **P** is engaged automatically and the electric parking brake applied:

- if you remove the key from the ignition lock
- if you switch off the engine using the Start/Stop button and open the driver's or front-passenger door
- if you open the driver's door while travelling at low speed in transmission position **D** or **R**
- when HOLD (▷ page 193) or DISTRONIC PLUS (▷ page 181) brakes your vehicle until it is stationary and at least one of the following conditions is fulfilled:
 - the engine is switched off
 - the driver's door is open and the seat belt is not fastened
 - there is a system malfunction
 - the power supply is insufficient

Engaging reverse gear R

- L** Only shift the automatic transmission to **R** when the vehicle is stationary.
 - ▶ When the vehicle is stationary, depress the brake pedal.
 - ▶ Push the selector lever forwards past the first point of resistance.
- i** When reverse gear is engaged and the ECO start/stop function is switched on, the engine starts up automatically (▷ page 158).

Shifting to neutral (N)

- ▶ When the vehicle is stationary, depress the brake pedal.
- ▶ Push the selector lever forwards or back to the first point of resistance.

- i** If the vehicle is braked to a standstill when in neutral **N** and the brake pedal is kept depressed, the ECO start/stop function switches the engine off automatically (▷ page 157).

Staying in neutral (N)

WARNING

If children are left unsupervised in the vehicle, they could:

- open the doors, thus endangering other people or road users.
- get out and disrupt traffic.
- operate the vehicle's equipment.

Additionally, children could set the vehicle in motion if, for example, they:

- release the parking brake.
- shift the automatic transmission out of parking position **P**.
- start the engine.

There is a risk of an accident and injury.

When leaving the vehicle, always take the key with you and lock the vehicle. Never leave children or animals unattended in the vehicle. Always keep the key out of reach of children.

With the key:

- make sure the ignition is switched on
- when the vehicle is stationary, depress the brake pedal and keep it depressed
- select neutral **N**
- release the brake pedal
- if the electric parking brake is applied, release it
- switch off the ignition and leave the key in the ignition lock

With KEYLESS-GO:

- make sure the ignition is switched on
- when the vehicle is stationary, depress the brake pedal and keep it depressed
- engage park position **P**
- release the brake pedal

- remove the Start/Stop button from the ignition lock
- insert the key into the ignition lock
- switch on the ignition
- depress the brake pedal and keep it depressed
- select neutral **N**
- release the brake pedal
- if the electric parking brake is applied, release it
- switch off the ignition and leave the key in the ignition lock

Shifting to transmission position **D**

- ▶ When the vehicle is stationary, depress the brake pedal.
- ▶ Push the selector lever back past the first point of resistance.

i If the vehicle is braked to a standstill when in transmission position **D** (▷ page 157) and the brake pedal is kept depressed, the ECO start/stop function switches the engine off automatically.

Transmission position and drive program display

Display in transmission positions **P, R** and **N**



- ① Transmission position: currently selected transmission position will be highlighted
- ② Drive program (**E/S/M**)

In addition to drive program ② being shown in the multifunction display, the currently selected drive program is indicated in red on the program selector button.

Display when in transmission position **D**

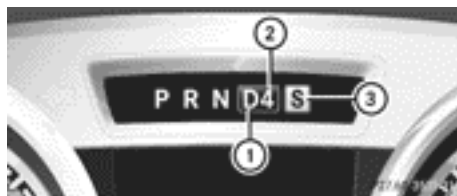

- ① Transmission position
- ② Gear
- ③ Drive program (**E/S**)

If you have restricted the shift range, the selected shift range and gear, e.g. D4, are shown at position ①.

Display when in transmission position **D** and drive program **M**



- ① Gear
- ② Drive program (**M**)

Transmission positions

P

Park position

This prevents the vehicle from rolling away when stopped. Do not shift the transmission into position **P** (▷ page 161) unless the vehicle is stationary. The parking lock should not be used as a brake when parking. In order to secure the vehicle, always engage the electric parking brake in addition to the parking lock.

If the key is removed from the ignition lock, the transmission is locked.

The automatic transmission shifts into **P** automatically:

- when the key is removed from the ignition lock.
- when the engine is switched off with the transmission in position **R** or **D** and one of the doors is opened.

In the event of a malfunction of the vehicle's electronics, the transmission may lock in position **P**.

Have the vehicle electronics checked immediately at a qualified specialist workshop.

R

Reverse gear

Only shift the transmission to **R** when the vehicle is stationary.

N

Neutral

Do not shift the transmission to **N** while driving. Otherwise, the automatic transmission could be damaged.

No power is transmitted from the engine to the drive wheels.

Releasing the brakes will allow you to move the vehicle freely, e.g. to push it or tow it.

If ESP[®] is deactivated or faulty: only shift the transmission to position **N** if the vehicle is in danger of skidding, e.g. on icy roads.

! Rolling in neutral **N** can lead to damage to the transmission.

D

Drive

The automatic transmission changes gear automatically. All forward gears are available.

Changing gear

The automatic transmission shifts to the individual gears automatically when it is in transmission position **D**. Gearshifting is determined by:

- a shift range restriction, if selected
- the selected drive program **E**, **S** or **M** (▷ page 165)
- the position of the accelerator pedal
- the road speed

Driving tips

Accelerator pedal position

Your style of driving influences how the automatic transmission shifts gear:

- little throttle: early upshifts
- more throttle: late upshifts

Double-clutch function

When shifting down, the double-clutch function is active regardless of the currently selected drive program. The double-clutch function reduces load change reactions and is conducive to a sporty driving style. The sound generated by the double-clutch function depends on the drive program selected.

Kickdown

Use kickdown for maximum acceleration.

- ▶ Depress the accelerator pedal beyond the pressure point.
The transmission shifts to a lower gear depending on the engine speed.
- ▶ Ease off the accelerator pedal once the desired speed is reached.
The automatic transmission shifts back up.

Program selector button

Selecting drive program

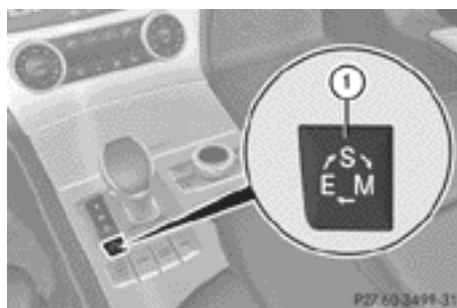

Program selector button

Program selector button ① allows you to choose between different driving characteristics.

- ▶ Press program selector button ① repeatedly until the letter for the desired gearshift program appears in the multifunction display in the speedometer.

- **E** Economy: comfortable, economical driving
- **S** Sport: sporty driving style
- **M** Manual: manual gearshifting

- ① The automatic transmission switches to automatic drive program **E** each time the engine is started.
- ① Further information on the "Automatic drive program" (▷ page 166).

Drive program for AMG vehicles



With the drive program selector switch, you can choose from a range of different transmission configurations or select the RACE START drive mode.

- ▶ Turn drive program selector ① until the desired drive program appears in the multifunction display.
 - **C** Controlled Efficiency: comfortable engine and transmission design that provides for optimum fuel consumption
 - **S** Sport: sporty engine and transmission settings
 - **S+** SportPlus: extremely sporty engine and transmission settings
 - **M** Manual: manual gearshifting
 - **RS driving mode** RACE START: optimum acceleration dynamics from a standstill (SL 63 AMG only)

- ▶ Turn drive program selector switch ① until the desired drive program is shown in the multifunction display.
The drive program indicator on the drive program selector lights up red.

- ❗ The automatic transmission switches to automatic drive program **C** each time the engine is started.
- ❗ **RS** cannot be selected during normal driving. For further information on RACE START, see (▷ page 194).

AMG button (SETUP)

You can save and call up the following pre-settings with the AMG button:

- Drive program (▷ page 165)
- Suspension tuning

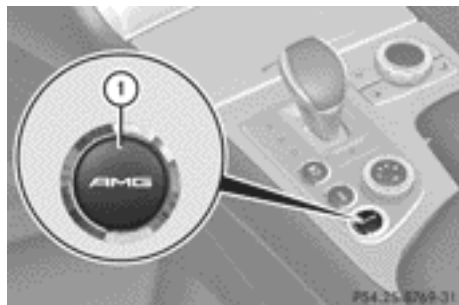

- ▶ **To store:** press and hold AMG button ① until you hear a tone.
- ▶ **To call up:** press AMG button ①. The stored drive program is selected.
- ▶ **To display:** briefly press AMG button ①. The multifunction display shows the SETUP in the AMG menu (▷ page 238).

Steering wheel gearshift paddles



- ① Left-hand steering wheel gearshift paddle
- ② Right-hand steering wheel gearshift paddle

In the automatic drive program, you can restrict or derestrict the shift range (▷ page 167) by using steering wheel gearshift paddles ① and ②.

In the manual drive program, you can change gear yourself by using the steering wheel gearshift paddles (▷ page 168).

- ❗ The full range of functions of the steering wheel gearshift paddles is available only once the operating temperature is reached.
- ❗ You can only change gear with the steering wheel gearshift paddles when the transmission is in position **D**.

Automatic drive program

Drive program **E** is characterised by the following:

- comfort-oriented engine and transmission settings
- optimal fuel consumption resulting from the automatic transmission shifting up sooner
- the vehicle pulling away more gently in forward and reverse gears, unless the accelerator pedal is depressed fully

- increased sensitivity. This improves driving stability on slippery road surfaces, for example
- the automatic transmission shifting up sooner. This results in the vehicle being driven at lower engine speeds and the wheels being less likely to spin

Drive program **S** is characterised by the following:

- sporty engine and transmission settings
- the vehicle pulling away in first gear
- the automatic transmission shifting up later
- as a result of the later automatic transmission shift points, the fuel consumption possibly being higher

Shift ranges

Introduction

When the automatic transmission is in position **D**, it is possible to restrict or derestrict the shift range.

The set shift range appears in the multifunction display. The automatic transmission shifts only as far as the selected gear.

Driving situations

3	To use the engine's braking effect
2	The braking effect of the engine can be utilised on downhill gradients or when driving: <ul style="list-style-type: none"> • on steep mountain roads • in mountainous terrain • in arduous conditions
1	The braking effect of the engine can be utilised on extremely steep downhill gradients and long downhill stretches.

Restricting the shift range



- ▶ Pull left-hand paddle ①.
The automatic transmission shifts down one gear and restricts the shift range to the relevant gear.

i If the engine exceeds the maximum engine speed when shifting down, the automatic transmission protects against engine damage by not shifting down.

i If the maximum engine speed for the shift range is reached and you continue to accelerate, the automatic transmission shifts up, even if the shift range is restricted. This is to prevent the engine from overrevving.

Extending the shift range

- ▶ Pull right-hand paddle ②.
The shift range is derestricted.

Clearing the shift range restriction

- ▶ Pull and hold right-hand steering wheel gearshift paddle ② until **D** is shown again in the multifunction display.

or

- ▶ Use the selector lever to shift the transmission to transmission position **D**.
The automatic transmission shifts from the current shift range directly to **D**.

Selecting the ideal shift range

- ▶ Pull and hold left-hand steering wheel gearshift paddle ① until the function is activated.

Depending on the selected drive program, the automatic transmission shifts to a gear which allows ideal acceleration and deceleration. To do this, the automatic transmission shifts down one or more gears.

Manual drive program

Activating the manual drive program

Manual drive program **M** differs from drive program **S** with regard to spontaneity, responsiveness and the smoothness of the gear changes.

You can select manual drive program **M** with the program selector button or the drive program selector (**AMG vehicles**). In manual drive program **M**, you can change gear using the steering wheel gearshift paddles if the transmission is in position **D**. The selected gear appears in the multifunction display.

- ▶ Press the program selector button repeatedly until **M** (▷ page 165) appears in the multifunction display.
- ▶ **AMG vehicles:** turn the drive program selector until **M** (▷ page 165) appears in the multifunction display.

Shifting up

- ▶ Pull the right-hand paddle (▷ page 166). The automatic transmission shifts up to the next gear.
Before the engine speed reaches the red area, an upshift indicator will be shown in the multifunction display.



- ① Upshift indicator
- ② Gear indicator

- ▶ Shift up a gear if upshift symbol ① appears in the multifunction display.

AMG vehicles

- In manual gearshift program **M**, the automatic transmission does not shift up automatically even when the engine limiting speed for the current gear is reached. When the engine limiting speed is reached, the fuel supply is cut to prevent the engine from overrevving. You must make sure that the engine speed does not reach the red area of the rev counter. Otherwise, there is a risk of engine damage.
- ▶ If the display colour of the multifunction display changes to red and upshift symbol ① appears, shift up a gear.

Downshifting

- ▶ Pull the left-hand paddle (▷ page 166). The automatic transmission shifts down to the next gear.

Maximum acceleration

- ▶ Pull the left-hand steering wheel gearshift paddle until the transmission selects the optimum gear for the current speed.
- ❗ If you brake the vehicle or stop without shifting down, the automatic transmission will shift down to a gear that will allow the vehicle to accelerate or pull away again.

Kickdown

You can also use kickdown for maximum acceleration in manual drive program **M**.

- ▶ Depress the accelerator pedal beyond the pressure point.

The transmission shifts to a lower gear depending on the engine speed.

- ▶ **i AMG vehicles:** it is not possible to use kickdown in manual drive program **M**.

Deactivating the manual drive program

- ▶ Press the program selector button (▷ page 165) repeatedly until **E** or **S** appears in the multifunction display.
- ▶ **AMG vehicles:** turn the drive program selector until **C**, **S** or **S+**(▷ page 165) appears in the multifunction display.

Problems with the transmission

Problem	Possible causes/consequences and ► Solutions
The transmission has problems shifting gear.	The transmission is losing oil. ► Have the transmission checked at a qualified specialist workshop immediately.
The acceleration ability is deteriorating. The transmission no longer changes gear.	The transmission is in emergency mode. It is only possible to shift into second gear and reverse gear. ► Stop. ► Shift the transmission to position P . ► Switch off the engine. ► Wait at least ten seconds before restarting the engine. ► Shift the transmission to position D or R . If D is selected, the transmission shifts into second gear; if R is selected, the transmission shifts into reverse gear. ► Have the transmission checked immediately at a qualified specialist workshop, e.g. a Mercedes-Benz Service Centre.

Refuelling

Important safety notes

 **WARNING**

Fuel is highly flammable. If you handle fuel incorrectly, there is a risk of fire and explosion.

You must avoid fire, naked flames, creating sparks and smoking. Switch off the engine and, if applicable, the auxiliary heating before refuelling.

 **WARNING**

Fuels are poisonous and hazardous to health. There is a danger of injury.

Do not swallow fuel or let it come into contact with skin, eyes or clothing. Do not inhale fuel vapours. Keep fuels out of the reach of children.

If you or others come into contact with fuel, observe the following:

- Wash the fuel off any affected areas of skin with water and soap immediately.
- If you get fuel in your eyes, rinse them thoroughly with clean water immediately. Seek immediate medical attention.
- If fuel is swallowed, seek immediate medical attention. Do not induce vomiting.
- Change any clothing that has come into contact with fuel immediately.

 **WARNING**

Electrostatic charge can cause sparks and thereby ignite fuel vapours. There is a risk of fire and explosion.

Always touch the vehicle body before opening the fuel filler flap or touching the fuel pump nozzle. This discharges any electrostatic charge that may have built up.

- ❗ Do not use diesel to refuel vehicles with a petrol engine. Do not switch on the ignition if you accidentally refuel with the wrong

fuel. Otherwise, the fuel will enter the fuel system. Even small amounts of the wrong fuel could result in damage to the fuel system and the engine. The repair costs are high. Notify a qualified specialist workshop and have the fuel tank and fuel lines drained completely.

- ❗ Overfilling the fuel tank could damage the fuel system.
- ❗ Take care not to spill any fuel on painted surfaces. You could otherwise damage the paintwork.
- ❗ Use a filter when adding fuel from a fuel can. The fuel lines and/or the diesel injection system could otherwise be blocked by particles from the fuel can.

Do not get into the vehicle again during the refuelling process. Otherwise, electrostatic charge could build up again.

If you overfill the fuel tank, some fuel may spray out when you remove the fuel pump nozzle.

For further information on fuel and fuel quality (▷ page 587).

Refuelling

Opening/closing the fuel filler flap

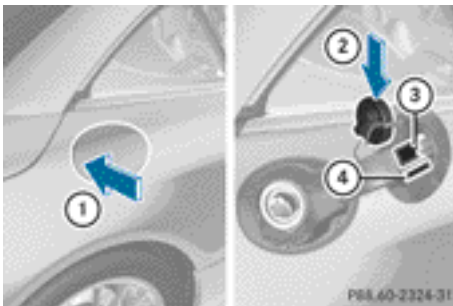

- ① To open the fuel filler flap
- ② To insert the fuel filler cap
- ③ Tyre pressure table
- ④ Fuel type to be refuelled

The fuel filler flap is unlocked or locked automatically when you open or close the vehicle with the key or using KEYLESS-GO.

The position of the fuel filler cap  is displayed in the instrument cluster. The arrow next to the filling pump indicates the side of the vehicle.

Opening

- ▶ Switch off the engine.
- ▶ Remove the key from the ignition lock.
- ▶ KEYLESS-GO: open the driver's door. This corresponds to key position **0**: "key removed".
The driver's door can be closed again.
- ▶ Press the fuel filler flap in the direction of arrow ①.
The fuel filler flap opens slightly.
- ▶ Open the fuel filler flap fully.
- ▶ Turn the fuel filler flap anti-clockwise and remove it.
- ▶ Insert the fuel filler cap into the holder bracket on the inside of filler flap ②.
- ▶ Completely insert the filler neck of the fuel pump nozzle into the tank and refuel.
- ▶ Only fill the tank until the pump nozzle switches off.

- ❗ Do not add any more fuel after the pump stops filling for the first time. Otherwise, fuel could leak out.

Closing

- ▶ Place fuel filler cap on the fuel filler neck and turn clockwise until it engages.
- ▶ Close the fuel filler flap.
- ❗ Close the fuel filler flap before locking the vehicle.

Problems with the fuel and fuel tank

Problem	Possible causes/consequences and ► Solutions
Fuel is leaking from the vehicle.	<p>The fuel line or the fuel tank is faulty.</p> <p> WARNING</p> <p>There is a risk of fire or explosion.</p> <ul style="list-style-type: none"> ► Turn the key to position 0 in the ignition lock and remove it immediately (▷ page 153). ► Do not restart the engine under any circumstances. ► Consult a qualified specialist workshop.
The fuel filler flap cannot be opened.	<p>The fuel filler flap is not unlocked.</p> <p>or</p> <p>The key battery is discharged.</p> <ul style="list-style-type: none"> ► Unlock the vehicle (▷ page 85). <p>or</p> <ul style="list-style-type: none"> ► Unlock the vehicle using the emergency key element (▷ page 86).
	<p>The fuel filler flap is unlocked, but the opening mechanism is jammed.</p> <ul style="list-style-type: none"> ► Consult a qualified specialist workshop.

Parking

Important safety notes

 **WARNING**

If flammable materials such as leaves, grass or twigs are exposed to prolonged contact to parts of the exhaust system that heat up, they could ignite. There is a risk of fire.

Park the vehicle so that no flammable materials come into contact with parts of the vehicle which are hot. Take particular care not to park on dry grassland or harvested grain fields.

 **WARNING**

If you switch off the ignition while driving, safety-relevant functions are only available with limitations, or not at all. This could affect, for example, the power steering and the brake

boosting effect. You will require considerably more effort to steer and brake. There is a risk of an accident.

Do not switch off the ignition while driving.

 **WARNING**

If you leave children unsupervised in the vehicle, they could set it in motion by, for example:

- releasing the parking brake
- shifting the automatic transmission out of the parking position **P**
- starting the engine.

They could also operate the vehicle's equipment. There is a risk of an accident and injury.

When leaving the vehicle, always take the key with you and lock the vehicle. Never leave children unsupervised in the vehicle.

! A moving vehicle can lead to damage to the vehicle or damage to the drive train.

To ensure that the vehicle is secured against rolling away unintentionally:

- the electric parking brake must be applied
- the transmission must be in position **P** and the key must be removed from the ignition lock
- on uphill or downhill gradients, turn the front wheels towards the kerb.

Switching off the engine

Important safety notes

WARNING

The automatic transmission switches to neutral position **N** when you switch off the engine. The vehicle may roll away. There is a risk of an accident.

After switching off the engine, always switch to parking position **P**. Prevent the parked vehicle from rolling away by applying the parking brake.

Vehicles with automatic transmission

- ▶ **Vehicles with a key:** move the transmission to position **P**.
- ▶ Turn the key to position **0** in the ignition lock and remove it. The immobiliser is activated.
- ▶ **Vehicles with KEYLESS-GO:** press the Start/Stop button (▷ page 153). The engine stops and all the indicator lamps in the instrument cluster go out. When the driver's door is closed, this corresponds to key position **1**. When the driver's door is open, this corresponds to key position **0** (▷ page 153).

i The engine can be switched off while the vehicle is in motion by pressing and holding the Start/Stop button for about three seconds. This function operates independently

of the ECO start/stop automatic engine switch-off function.

Electric parking brake

General notes

WARNING

If you leave children unsupervised in the vehicle, they could set it in motion by, for example:

- releasing the parking brake
- shifting the automatic transmission out of the parking position **P**
- starting the engine.

They could also operate the vehicle's equipment. There is a risk of an accident and injury.

When leaving the vehicle, always take the key with you and lock the vehicle. Never leave children unsupervised in the vehicle.

i The electric parking brake carries out a function check at regular intervals when the engine is switched off. Noises that occur are normal.

Engaging and releasing manually



- ▶ **To engage:** push handle **①**.
When the electric parking brake is applied, the  red indicator lamp lights up in the instrument cluster.
- i** The electric parking brake can also be applied when the key is removed.

► **To release:** pull handle ①.

The red  indicator lamp in the instrument cluster goes out.

- ❗ The electric parking brake can only be released:
 - when the key is in position **1** in the ignition lock or
 - the ignition was switched on using the Start/Stop button.

Applying automatically

The electric parking brake is applied automatically:

- if DISTRONIC PLUS brings the vehicle to a standstill or
- if the HOLD function is keeping the vehicle stationary.

In addition, at least one of the following conditions must be fulfilled:

- the engine is switched off, unless it is automatically switched off by the ECO start/stop function.
- the driver's seat belt is not inserted in the belt buckle and the driver's door is open.
- the vehicle is stationary for a lengthy period.

The red  indicator lamp in the instrument cluster lights up.

- ❗ The electric parking brake is not automatically applied if the engine is switched off by the ECO start/stop function.

Releasing automatically

The electric parking brake is released automatically when all of the following conditions are fulfilled:

- the engine is running.
- the transmission is in position **D** or **R**.
- the driver's seat belt is fastened.
- you depress the accelerator pedal.

If the transmission is in position **R**, the boot lid must be closed.

If your seat belt is not fastened, the following conditions must be fulfilled to automatically release the electric parking brake:

- the driver's door is closed
- you have shifted out of **P** or you have previously driven faster than 3 km/h.

Emergency braking

The vehicle can also be braked during an emergency using the electric parking brake.

- While driving, push handle ① of the electric parking brake.

- ❗ The vehicle is braked for as long as the handle of the electric parking brake is pressed. The longer the electric parking brake handle is depressed, the greater the braking force.

During braking:

- a warning tone sounds
- the **Release parking brake** message appears.
- the red  indicator lamp in the instrument cluster flashes

When the vehicle has been braked to a standstill, the electric parking brake is engaged.

Parking up the vehicle

If you leave the vehicle parked up for longer than four weeks, the battery may be damaged by exhaustive discharging.

- Disconnect the battery or connect it to a trickle charger.

- ❗ You can obtain information about trickle chargers from a qualified specialist workshop.

If you leave the vehicle parked up for longer than six weeks, the vehicle may suffer damage as a result of lack of use.

- Visit a qualified specialist workshop and seek advice.

Driving tips

General notes

Important safety notes

WARNING

If you switch off the ignition while driving, safety-relevant functions are only available with limitations, or not at all. This could affect, for example, the power steering and the brake boosting effect. You will require considerably more effort to steer and brake. There is a risk of an accident.

Do not switch off the ignition while driving.

WARNING

Operating mobile communications equipment while driving distracts you from paying attention to traffic conditions. This could also cause you to lose control of the vehicle. There is a risk of an accident.

Use this device only when the vehicle is stationary.

Observe the legal requirements for the country in which you are driving. Some jurisdictions prohibit the driver from using a mobile phone while driving a vehicle.

If you make a call while driving, always use hands-free mode. Only operate the telephone when the traffic situation permits. If you are unsure, pull over to a safe location and stop before operating the telephone.

Bear in mind that at a speed of only 30 mph (approximately 50 km/h), the vehicle covers a distance of 44 feet (approximately 14 m) per second.

Drive sensibly – save fuel

Observe the following tips to save fuel:

- The tyres should always be inflated to the recommended tyre pressure.
- Remove unnecessary loads.
- Warm up the engine at low engine speeds.

- Avoid frequent acceleration or braking.
- Observe the service intervals in the Service Booklet or in the service interval display. Have all the maintenance work carried in accordance with Daimler AG regulations.

Fuel consumption also increases when driving in cold weather, in stop-start traffic, on short journeys and in hilly terrain.

Braking

Important safety notes

WARNING

If you shift down on a slippery road surface in an attempt to increase the engine's braking effect, the drive wheels could lose their grip. This increases the risk of skidding and having an accident.

Do not shift down for additional engine braking on a slippery road surface.

Downhill gradients

On long and steep downhill gradients, especially if the vehicle is laden, you must select shift range **1**, **2** or **3** in good time.

 This also applies if you have activated cruise control, SPEEDTRONIC or DIS-TRONIC.

This will use the braking effect of the engine, so less braking will be required to prevent the vehicle from gaining speed. This relieves the load on the brake system and prevents the brakes from overheating and wearing too quickly.

Heavy and light loads

WARNING

The braking system can overheat if you leave your foot on the brake pedal while driving. This increases the braking distance and could even cause the braking system to fail. There is a risk of an accident.

Never use the brake pedal as a footrest. Do not simultaneously depress both the brake pedal and the accelerator pedal while driving.

! Depressing the brake pedal constantly results in excessive and premature wear to the brake pads.

If the brakes have been subjected to a heavy load, do not stop the vehicle immediately, but drive on for a short while. This allows the air flow to cool the brakes more quickly.

If the brakes have been used only moderately, you should occasionally test their effectiveness. To do this, brake more firmly from a higher speed. This improves the grip of the brakes.

Wet road surfaces

If you have driven for a long time in heavy rain without braking, there may be a delayed reaction from the brakes when braking for the first time.

This may also occur after the vehicle has been washed.

You have to depress the brake pedal more firmly. Maintain a greater distance from the vehicle in front.

After driving on a wet road or having the vehicle washed, brake firmly while paying attention to the traffic conditions. This will warm up the brake discs, thereby drying them more quickly and protecting them against corrosion.

Limited braking performance on salt-treated roads

If you drive on salt-treated roads, a layer of salt may form on the brake discs and pads. This can increase the braking distance considerably.

- Brake occasionally to remove any possible salt residue. Ensure that you do not endanger other road users when doing so.
- Carefully depress the brake pedal at the end of the journey and when starting the next journey.
- Maintain a much greater distance to the vehicle in front.

New brake pads/linings

New or replaced brake pads and discs only reach their optimum braking effect after several hundred kilometres of driving. Compensate for the reduced braking effect by applying greater force to the brake pedal.

For safety reasons, Mercedes-Benz recommends that you only have brake pads/linings fitted to your vehicle which have been approved for Mercedes-Benz vehicles or which correspond to an equivalent quality standard. Brake pads/linings which have not been approved for Mercedes-Benz vehicles or which are not of an equivalent quality could affect your vehicle's operating safety.

High-performance and ceramic brake system for AMG vehicles

The AMG brake systems are designed for heavy loads. This may lead to noise when braking. This is dependent on:

- speed
- braking force
- ambient conditions, e.g. temperature and humidity

The wear of individual components of the brake system, such as the brake pads/linings or brake discs, depends on the individual driving style and operating conditions.

For this reason, it is impossible to state a mileage (service life) that will be valid under all circumstances. An aggressive driving style will lead to high wear. You can obtain more information on this from a qualified specialist workshop.

New brake pads/brake pads and discs that have been replaced only achieve optimum braking effect after several hundred kilometres of driving. Compensate for the reduced braking effect by applying greater force to the brake pedal. Always be aware of this and adapt your driving and braking accordingly during the running-in period.

Excessive heavy braking results in correspondingly high brake wear. Observe the brake system warning lamp in the instrument cluster and note any brake status messages in the multifunction display. If you regularly drive at high speeds, it is particularly important to have the brake system checked and maintained regularly.

Driving on wet roads

Aquaplaning

If water has accumulated to a certain depth on the road surface, there is a danger of aquaplaning occurring, even if:

- you are driving at low speeds
- the tyres have adequate tread depth

For this reason, do not drive in tyre ruts and brake carefully.

Driving on flooded roads

! Bear in mind that vehicles travelling in front or in the opposite direction create waves. This may cause the maximum permissible water depth to be exceeded.

These notes must be observed under all circumstances. You could otherwise damage the engine, the electronics or the transmission.

If you have to drive on stretches of road on which water has collected, please bear in mind that:

- the maximum permissible still water depth is 12 cm
- you should drive no faster than walking pace

Winter driving

Important safety notes

WARNING

If you shift down on a slippery road surface in an attempt to increase the engine's braking effect, the drive wheels could lose their grip. This increases the risk of skidding and having an accident.

Do not shift down for additional engine braking on a slippery road surface.

DANGER

If the exhaust pipe is blocked or adequate ventilation is not possible, poisonous gases such as carbon monoxide (CO) may enter the vehicle. This is the case, e.g. if the vehicle becomes trapped in snow. There is a risk of fatal injury.

If you leave the engine or the auxiliary heating running, make sure the exhaust pipe and area around the vehicle are clear of snow. To ensure an adequate supply of fresh air, open a window on the side of the vehicle that is not facing into the wind.

! Take care not to damage the sealing strip and the moulding on the side of the rear window when scraping ice off the rear window.

Have your vehicle winterproofed at a qualified specialist workshop at the onset of winter.

Observe the notes in the "Winter operation" section (▷ page 564).

Driving with summer tyres

Observe the notes in the "Winter operation" section (▷ page 564).

Slippery road surfaces

WARNING

If you shift down on a slippery road surface in an attempt to increase the engine's braking effect, the drive wheels could lose their grip.

This increases the risk of skidding and having an accident.

Do not shift down for additional engine braking on a slippery road surface.

If the vehicle threatens to skid or cannot be stopped when moving at low speed:

- ▶ Move the transmission to position **N**.
- ▶ Try to bring the vehicle under control by using corrective steering.

You should drive particularly carefully on slippery road surfaces. Avoid sudden acceleration, steering and braking manoeuvres.

The outside temperature indicator is not designed to serve as an ice-warning device and is therefore unsuitable for that purpose. Changes in the outside temperature are displayed after a short delay.

Indicated temperatures just above the freezing point do not guarantee that the road surface is free of ice. The road may still be icy, especially in wooded areas or on bridges. You should pay special attention to road conditions when temperatures are around freezing point.

- i** For more information on driving with snow chains, see (▷ page 565).

Driving systems

Cruise control

Important safety notes

If you fail to adapt your driving style, cruise control can neither reduce the risk of accident nor override the laws of physics. Cruise control cannot take road, weather and traffic conditions into account. Cruise control is only an aid. You are responsible for the distance to the vehicle in front, for vehicle speed, for braking in good time and for maintaining lane.

Do not use cruise control:

- in road and traffic conditions which do not allow you to maintain a constant speed, e.g. heavy traffic or winding roads.
- on slippery roads. Braking or accelerating may cause the drive wheels to lose traction and the vehicle could then skid.
- when there is poor visibility, e.g. due to fog, heavy rain or snow.

If there is a change of drivers, advise the new driver of the stored speed.

General notes

Cruise control maintains a constant road speed for you. It brakes automatically in order to avoid exceeding the set speed. On long and steep downhill gradients, especially if the vehicle is laden, you must select shift range **1, 2 or 3** in good time (▷ page 167). By doing so, you will make use of the braking effect of the engine. This relieves the load on the brake system and prevents the brakes from overheating and wearing too quickly.

Use cruise control only if road and traffic conditions make it appropriate to maintain a steady speed for a prolonged period. You can store any road speed above 30 km/h.

Cruise control lever

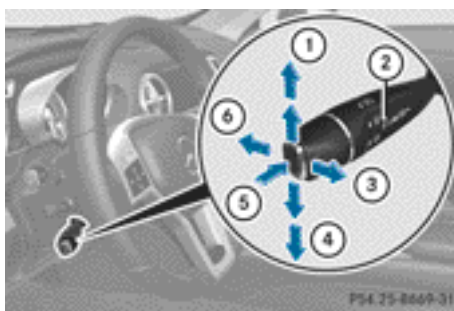

Cruise control lever

- ① To store the current speed or a higher speed
- ② LIM indicator lamp

- ③ To store the current speed and call up the last stored speed
- ④ To store the current speed or a lower speed
- ⑤ To switch between cruise control and variable SPEEDTRONIC
- ⑥ To deactivate cruise control

You can operate cruise control and variable SPEEDTRONIC with the cruise control lever. The LIM indicator lamp ② on the cruise control lever indicates which system you have selected:

- **LIM indicator lamp ② off:** cruise control is selected.
- **LIM indicator lamp ② on:** variable SPEEDTRONIC is selected.

When you activate cruise control, the stored speed is shown in the multifunction display for five seconds. The speed is then permanently displayed in the status indicator together with the  symbol.

Selecting cruise control

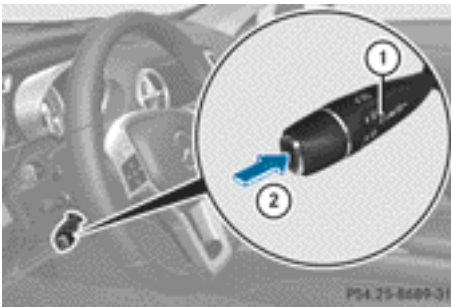

Cruise control lever

- ▶ Check whether LIM indicator lamp ① is off. If it is off, cruise control is already selected. If it is not, press the cruise control lever in the direction of arrow ②. LIM indicator lamp ① in the cruise control lever goes out. Cruise control is selected.

Storing, maintaining and calling up a speed

Storing and maintaining the speed

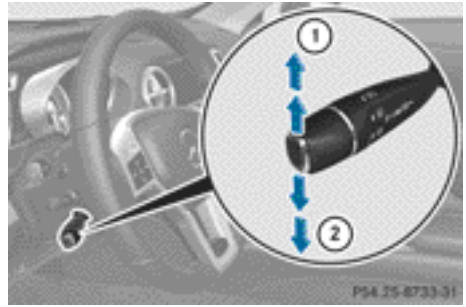

Cruise control lever

- ▶ Accelerate the vehicle to the desired speed.
- ▶ Briefly press the cruise control lever up ① or down ②.
- ▶ Remove your foot from the accelerator pedal. Cruise control is activated. The vehicle automatically maintains the stored speed.

You can store the current speed if you are driving faster than 30 km/h.

- ❗ Cruise control may be unable to maintain the stored speed on uphill gradients. The stored speed is resumed when the gradient evens out. Cruise control maintains the stored speed on downhill gradients by automatically applying the brakes.

Storing or calling up the speed

WARNING

If you call up a stored speed and this is different from the current speed, the vehicle accelerates or brakes. If you do not know what the stored speed is, the vehicle may accelerate or brake unexpectedly. There is a risk of an accident.

Take the traffic conditions into account before calling up the stored speed. If you do not know what the stored speed is, store the desired speed again.



Cruise control lever

- ▶ Briefly pull the cruise control lever towards you ①.
- ▶ Remove your foot from the accelerator pedal.
The first time cruise control is activated, it stores the current speed or regulates the speed of the vehicle to the previously stored speed.

Setting a speed

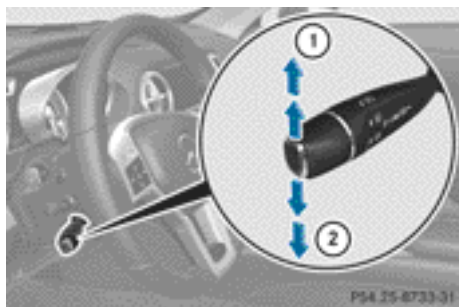

Cruise control lever

- ▶ Press the cruise control lever up ① for a higher speed or down ② for a lower speed.
- ▶ Keep the cruise control lever pressed until the desired speed is reached.
- ▶ Release the cruise control lever.
The new speed is stored.
- ▶ **To adjust the set speed in 1 km/h increments:** briefly press the cruise control

lever up ① to the pressure point for a higher speed or down ② for a lower speed. The last speed stored is increased or reduced.

- ▶ **To adjust the set speed in 10 km/h increments:** briefly press the cruise control lever up ① past the pressure point for a higher speed, or down ② for a lower speed.
The last speed stored is increased or reduced.

i Cruise control is not deactivated if you depress the accelerator pedal. For example, if you accelerate briefly to overtake, cruise control adjusts the vehicle's speed to the last speed stored after you have finished overtaking.

Deactivating cruise control

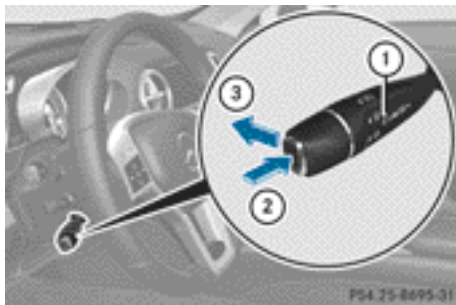

Cruise control lever

There are several ways to deactivate cruise control:

- ▶ Briefly press the cruise control lever forwards ③.
- or
- ▶ Brake
- or
- ▶ Briefly press the cruise control lever in the direction of arrow ②.
Variable SPEEDTRONIC is selected. LIM indicator lamp ① in the cruise control lever lights up.

Cruise control is automatically deactivated if:

- you engage the electric parking brake.
- you are driving at less than 30 km/h.
- ESP® intervenes or you deactivate ESP®.
- on vehicles with manual transmission, you shift to a gear that is too high, and as a result the engine speed is too low.
- on vehicles with manual transmission, you shift to a gear that is too high, and as a result the engine speed is too low.
- you shift the transmission to position **N** while driving.

If cruise control is deactivated, you will hear a warning tone. You will see the **Cruise control off** message in the multifunction display for approximately five seconds.

- ❗ The last speed stored is cleared when you switch off the engine.

DISTRONIC PLUS

Important safety notes

WARNING

DISTRONIC PLUS does not react to:

- people or animals
- stationary obstacles on the road, e.g. stopped or parked vehicles
- oncoming and crossing traffic

As a result, DISTRONIC PLUS may neither give warnings nor intervene in such situations. There is a risk of an accident.

Always pay careful attention to the traffic situation and be ready to brake.

WARNING

DISTRONIC PLUS cannot always clearly identify other road users and complex traffic situations.

In such cases, DISTRONIC PLUS may:

- give an unnecessary warning and then brake the vehicle
- neither give a warning nor intervene
- accelerate unexpectedly

There is a risk of an accident.

Continue to drive carefully and be ready to brake, in particular when warned to do so by DISTRONIC PLUS.

WARNING

DISTRONIC PLUS brakes your vehicle with up to 40% of the maximum braking force. If this braking force is insufficient, DISTRONIC PLUS warns you visually and audibly. There is a risk of an accident.

In such cases, apply the brakes yourself and try to take evasive action.

- ❗ If DISTRONIC PLUS or the HOLD function is activated, the vehicle brakes automatically in certain situations. To prevent damage to the vehicle, deactivate DISTRONIC PLUS and the HOLD function in the following or other similar situations:

- when towing the vehicle
- in the car wash

If you fail to adapt your driving style, DISTRONIC PLUS can neither reduce the risk of accident nor override the laws of physics. DISTRONIC PLUS cannot take account of road and weather conditions or traffic conditions. DISTRONIC PLUS is only an aid. You are responsible for the distance to the vehicle in front, for vehicle speed, for braking in good time, and for staying correctly in lane.

Do not use DISTRONIC PLUS:

- in road and traffic conditions which do not allow you to maintain a constant speed (e.g. in heavy traffic or on winding roads).
- on smooth or slippery roads. Braking or accelerating can cause the drive wheels to

lose traction and the vehicle could then skid.

- when there is poor visibility, e.g. due to fog, heavy rain or snow.

DISTRONIC PLUS may not detect narrow vehicles driving in front, e.g. motorcycles, or vehicles driving on a different line.

In particular, the detection of obstacles can be impaired if there is:

- dirt on the sensors or anything else covering the sensors
- snow or heavy rain
- interference by other radar sources
- the possibility of strong radar reflections, for example, in multi-storey car parks

If DISTRONIC PLUS no longer detects a vehicle in front, it may unexpectedly accelerate to the speed stored.

This speed can:

- be too high for a filter lane or a slip road
- be so high in the right lane that you pass vehicles driving on the left
- be so high in the left lane that you pass vehicles driving on the right

If there is a change of drivers, advise the new driver of the speed stored.

General notes

DISTRONIC PLUS regulates the speed and automatically helps you maintain the distance to the vehicle detected in front. DISTRONIC PLUS brakes automatically so that the set speed is not exceeded.

On long and steep downhill gradients, especially if the vehicle is laden, you must select shift range **1**, **2** or **3** in good time (▷ page 167). By doing so, you will make use of the braking effect of the engine. This relieves the load on the brake system and prevents the brakes from overheating and wearing too quickly.

If a slower-moving vehicle is detected in front, DISTRONIC PLUS brakes your vehicle. It

maintains the preset distance to the vehicle in front.

If DISTRONIC PLUS detects that there is a risk of a collision, you will be warned visually and acoustically. Without your intervention, DISTRONIC PLUS cannot prevent a collision. An intermittent warning tone will then sound and the distance warning lamp will light up in the instrument cluster. Brake immediately to increase the distance to the vehicle driving in front, or take evasive action, provided it is safe to do so.

For DISTRONIC PLUS to assist you when driving, the radar sensor system must be:

- activated (▷ page 237)
- operational

i In some countries you must deactivate the radar sensor system (▷ page 237).

For further information about the radar sensor system; see (▷ page 595).

If there is no vehicle in front, DISTRONIC PLUS operates in the same way as cruise control in the speed range between 30 km/h and 200 km/h. If a vehicle is driving in front of you, DISTRONIC operates in the speed range between 0 km/h and 200 km/h.

Do not use DISTRONIC PLUS while driving on roads with steep gradients.

Cruise control lever

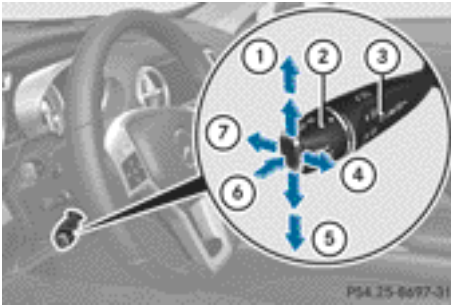

Cruise control lever

- ① To store the current speed or a higher speed
- ② To set the specified minimum distance
- ③ LIM indicator lamp
- ④ To store the current speed and call up the last stored speed
- ⑤ To store the current speed or a lower speed
- ⑥ To switch between DISTRONIC PLUS and variable SPEEDTRONIC
- ⑦ To deactivate DISTRONIC PLUS

With the cruise control lever, you can operate DISTRONIC PLUS and variable SPEEDTRONIC.

The LIM indicator lamp ③ on the cruise control lever indicates which system you have selected:

- **LIM indicator lamp ③ off:** DISTRONIC PLUS is selected.
- **LIM indicator lamp ③ on:** variable SPEEDTRONIC is selected.

Selecting DISTRONIC PLUS

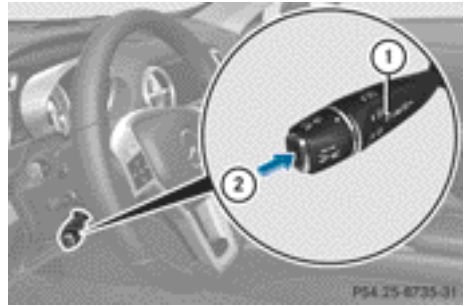

Cruise control lever

- ▶ Check whether LIM indicator lamp ① is off. If it is off, DISTRONIC PLUS is already selected. If it is not, press the cruise control lever in the direction of arrow ②. LIM indicator lamp ① in the cruise control lever goes out. DISTRONIC PLUS is selected.

Activating DISTRONIC PLUS; storing, maintaining and calling up a speed

Important safety notes

! If DISTRONIC PLUS or the HOLD function is activated, the vehicle brakes automatically in certain situations. To prevent damage to the vehicle, deactivate DISTRONIC PLUS and the HOLD function in the following or other similar situations:

- when towing the vehicle
- in the car wash

To activate DISTRONIC PLUS, the following conditions must be fulfilled:

- the engine must be running. It may take up to two minutes of driving before DISTRONIC PLUS is ready for use.
- your vehicle must not be secured by the electric parking brake.
- ESP[®] must be activated.
- the transmission must be in position **D**.
- the bonnet must be closed.

- the driver's door must be closed when you shift from **P** to **D** or your seat belt must be fastened.
- the front passenger door must be closed.
- the vehicle must not be skidding.

Activating while driving

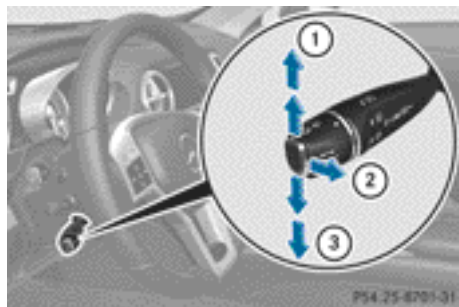

Cruise control lever

- ▶ Briefly pull the cruise control lever towards you ② or press it up ① or down ③. **DISTRONIC PLUS** is selected.
- ▶ Keep the cruise control lever pressed up ① or down ③ until the desired speed is set.
- ▶ Remove your foot from the accelerator pedal.
Your vehicle adapts its speed to that of the vehicle in front, but only up to the desired stored speed.

If the vehicle in front has been detected and is shown in the multifunction display, you can also activate **DISTRONIC PLUS** when driving at speeds below 30 km/h. If the vehicle in front is no longer detected and displayed, for example because it has changed lanes, **DISTRONIC PLUS** is deactivated. You will hear a warning tone if this is the case.

- ❗ If you do not fully release the accelerator pedal, the **DISTRONIC PLUS inactive** message appears in the multifunction display. The set distance to a slower-moving vehicle in front will then not be maintained. You will be driving at the speed you determine by the position of the accelerator pedal.

Activating when driving towards a stationary vehicle

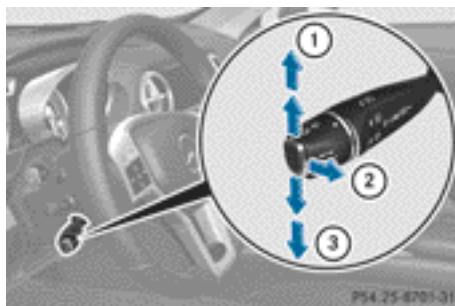

Cruise control lever

- ▶ Briefly pull the cruise control lever towards you ② or press it up ① or down ③. **DISTRONIC PLUS** is selected.
- ▶ Keep the cruise control lever pressed up ① or down ③ until the desired speed is set.

If the vehicle in front of you is stationary, you can only activate **DISTRONIC PLUS** once your vehicle is stationary as well.

- ❗ **DISTRONIC PLUS** can only be activated at under 30 km/h if a vehicle in front has been detected. Therefore, the **DISTRONIC PLUS** distance display in the instrument cluster should be activated (▷ page 231).

- ❗ You can use the cruise control lever to set the stored speed and the control on the cruise control lever to set the specified minimum distance (▷ page 187).

Pulling away and driving

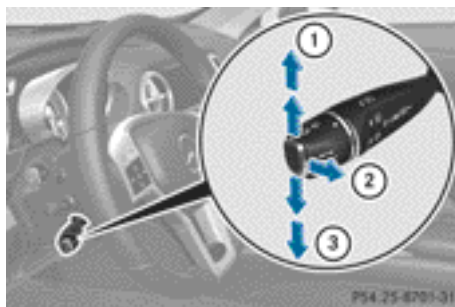

Cruise control lever

If you depress the brake, DISTRONIC PLUS is deactivated unless your vehicle is stationary.

- ▶ **If the vehicle in front pulls away:** remove your foot from the brake pedal.
- ▶ Briefly pull the cruise control lever towards you ② or press it up ① or down ③.

or

- ▶ Accelerate briefly.
Your vehicle pulls away and adapts its speed to that of the vehicle in front.

If there is no vehicle in front, DISTRONIC PLUS operates in the same way as cruise control.

If DISTRONIC PLUS detects that the vehicle in front has slowed down, it brakes your vehicle. It maintains the preset distance to the vehicle in front.

If DISTRONIC PLUS detects that there is a risk of a collision, you will be warned visually and acoustically. Without your intervention, DISTRONIC PLUS cannot prevent a collision. An intermittent warning tone will then sound and the distance warning lamp will light up in the instrument cluster. Brake immediately to increase the distance to the vehicle driving in front, or take evasive action, provided it is safe to do so.

If DISTRONIC PLUS detects a faster-moving vehicle in front, it increases the driving speed. However, the vehicle is only accelerated up to the speed you have stored.

Changing lanes

If you wish to change to the passing lane (in countries where traffic drives on the right, the passing lane is the left-hand lane), DISTRONIC PLUS supports you if:

- you are driving faster than 60 km/h.
- DISTRONIC PLUS is maintaining the distance to a vehicle in front.
- you have switched on the corresponding turn signal.
- DISTRONIC PLUS does not detect a danger of collision.

If these conditions are met, your vehicle is accelerated. Acceleration will be interrupted if changing lanes takes too long or if the distance between your vehicle and the vehicle in front becomes too small.

Vehicles with COMAND Online

- ❗ The following function is not operational in all countries.

DISTRONIC PLUS uses additional information from your navigation system so that it can react appropriately to certain traffic situations. This is the case if, while following a vehicle, DISTRONIC PLUS is active and you:

- approach or drive around a roundabout
- approach a T-junction
- turn off at a motorway exit

Even if the vehicle in front leaves the detection range, DISTRONIC PLUS temporarily maintains the current driving speed and does not accelerate. This is based on the current map data in the navigation system.

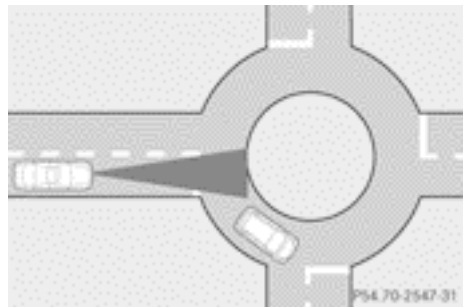

Example: roundabout

The current speed is maintained:

- approximately ten seconds before the roundabout/T-junction and for approximately 1.5seconds when driving on the roundabout
- approximately twelve seconds before reaching a motorway exit and approximately four seconds after the motorway exit

Afterwards, the vehicle accelerates back to the set speed you specified.

Stopping

WARNING

When leaving the vehicle, even if it is braked only by DISTRONIC PLUS, it could roll away if:

- there is a malfunction in the system or in the voltage supply.
- DISTRONIC PLUS has been deactivated with the cruise control lever, e.g. by a vehicle occupant or from outside the vehicle.
- the electrical system in the engine compartment, the battery or the fuses have been tampered with.
- the battery is disconnected.
- the accelerator pedal has been depressed, e.g. by a vehicle occupant.

There is a risk of an accident.

If you wish to exit the vehicle, always turn off DISTRONIC PLUS and secure the vehicle against rolling away.

Deactivate DISTRONIC PLUS (▷ page 188).

If DISTRONIC PLUS detects that the vehicle in front is stopping, it brakes your vehicle until it is stationary.

Once your vehicle is stationary, it remains stationary and you do not need to depress the brake. After a time, the electric parking brake secures the vehicle and relieves the service brake.

Depending on the specified minimum distance, your vehicle will come to a standstill at a sufficient distance behind the vehicle in front. The specified minimum distance is set using the control on the cruise control lever.

The electric parking brake secures the vehicle automatically if DISTRONIC PLUS is activated and:

- the driver's door is open and the driver's seat belt is unfastened.
- the engine is switched off, unless it is automatically switched off by the ECO start/stop function.
- a system fault occurs.
- the power supply is not sufficient.

If a fault occurs, then the transmission may also be shifted into position **P** automatically.

Storing the current speed and calling up the last stored speed

WARNING

If you call up a stored speed and this is different from the current speed, the vehicle accelerates or brakes. If you do not know what the stored speed is, the vehicle may accelerate or brake unexpectedly. There is a risk of an accident.

Take the traffic conditions into account before calling up the stored speed. If you do not know what the stored speed is, store the desired speed again.

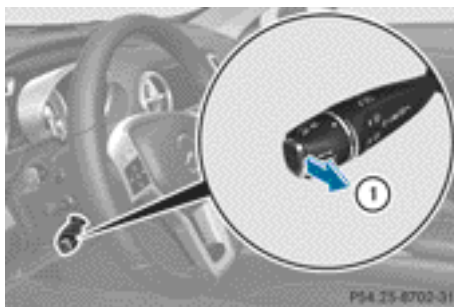

Cruise control lever

- ▶ Briefly pull the cruise control lever towards you ①.
- ▶ Remove your foot from the accelerator pedal.
DISTRONIC PLUS is activated. The first time it is activated, the current speed is stored. Otherwise, it sets the vehicle speed to the previously stored value.

Setting a speed

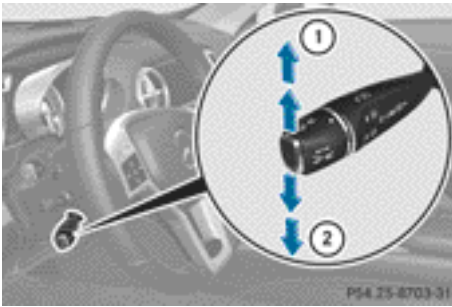

Cruise control lever

Keep in mind that it may take a brief moment until the vehicle has accelerated or braked to the set speed.

- ▶ Press the cruise control lever up ① for a higher speed or down ② for a lower speed.
- ▶ Keep the cruise control lever pressed until the desired speed is reached.
- ▶ Release the cruise control lever. The new speed is stored. DISTRONIC PLUS is activated and adjusts the vehicle's speed to the new speed stored.
- ▶ **To adjust the set speed in 1 km/h increments:** briefly press the cruise control lever up ① to the pressure point for a higher speed, or down ② for a lower speed. The last speed stored is increased or reduced.
- ▶ **To adjust the set speed in 10 km/h increments:** briefly press the cruise control lever up ① past the pressure point for a higher speed, or down ② for a lower speed. The last speed stored is increased or reduced.

Setting the specified minimum distance

You can set the specified minimum distance for DISTRONIC PLUS by varying the time span between one and two seconds. With this function, you can set the minimum distance that DISTRONIC PLUS keeps to the vehicle in front, dependent on vehicle speed. You can

see this distance in the multifunction display (▷ page 188).

Make sure that you maintain a sufficient and safe distance from the vehicle in front. Adjust the distance to the vehicle in front if necessary.

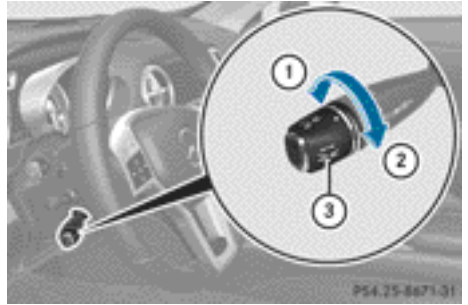

Cruise control lever

- ▶ **To increase:** turn control ③ in direction ②. DISTRONIC PLUS then maintains a greater distance between your vehicle and the vehicle in front.
- ▶ **To decrease:** turn control ③ in direction ①. DISTRONIC PLUS then maintains a shorter distance between your vehicle and the vehicle in front.

DISTRONIC PLUS displays in the instrument cluster

Displays in the speedometer



When DISTRONIC PLUS is activated, one or two segments ② in the set speed range light up.

If DISTRONIC PLUS detects a vehicle in front, segments ② between speed of the vehicle in front ③ and stored speed ① light up.

- ❶ For design reasons, the speed displayed in the speedometer may differ slightly from the speed set for DISTRONIC PLUS.

Display when DISTRONIC PLUS is deactivated



- ❶ Vehicle in front, if detected
- ❷ Distance indicator: current distance to the vehicle in front
- ❸ Specified minimum distance to the vehicle in front; adjustable
- ❹ Own vehicle
- ❺ Symbol for activated PRE-SAFE® Brake

- Select the **Distance display** function using the on-board computer (> page 231).

In the Assistance menu of the on-board computer, you can also activate or deactivate PRE-SAFE® Brake (> page 231).

Display when DISTRONIC PLUS is activated



- ❶ DISTRONIC PLUS activated
- ❷ Own vehicle
- ❸ Specified minimum distance to the vehicle in front; adjustable
- ❹ Vehicle in front, if detected

- Select the **Distance display** function using the on-board computer (> page 231).

You will initially see the stored speed for about five seconds when you activate DISTRONIC PLUS.

Deactivating DISTRONIC PLUS

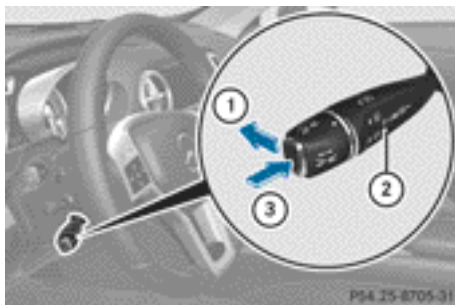

Cruise control lever

There are several ways to deactivate DISTRONIC PLUS:

- Briefly press the cruise control lever forwards ❶.

or

- Brake, unless the vehicle is stationary.

or

- ▶ Briefly press the cruise control lever in the direction of arrow ③.

Variable SPEEDTRONIC is selected. LIM indicator lamp ② in the cruise control lever lights up.

When you deactivate DISTRONIC PLUS, you will see the **DISTRONIC PLUS off** message in the multifunction display for approximately five seconds.

- ❗ The last speed stored remains stored until you switch off the engine.
- ❗ DISTRONIC PLUS is not deactivated if you depress the accelerator pedal. If you accelerate to overtake, DISTRONIC PLUS adjusts the vehicle's speed to the last speed stored after you have finished overtaking.

DISTRONIC PLUS is automatically deactivated if:

- you engage the electric parking brake or if the vehicle is automatically secured with the electric parking brake
- you are driving slower than 25 km/h and there is no vehicle in front, or if the vehicle in front is no longer detected
- ESP® intervenes or you deactivate ESP®
- the transmission is in the **P**, **R** or **N** position
- you switch off the radar sensor system (▷ page 237)
- you pull the cruise control lever towards you in order to pull away and the front-passenger door is open
- the vehicle has skidded

If DISTRONIC PLUS is deactivated, you will hear a warning tone. You will see the **DIS-TRONIC PLUS off** message in the multifunction display for approximately five seconds.

Tips for driving with DISTRONIC PLUS

General notes

The following contains descriptions of certain road and traffic conditions in which you must be particularly attentive. In such situations, brake if necessary. DISTRONIC PLUS is then deactivated.

Cornering, going into and coming out of a bend

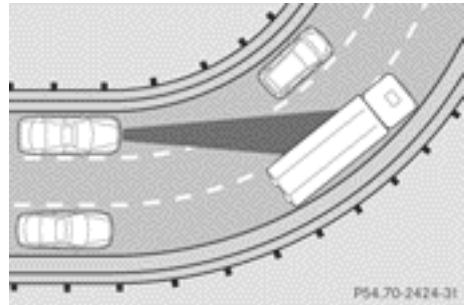

The ability of DISTRONIC PLUS to detect vehicles when cornering is limited. Your vehicle may brake unexpectedly or late.

Vehicles travelling on a different line

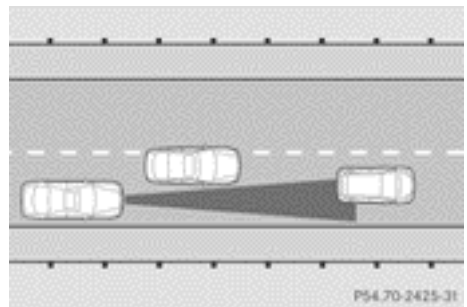

DISTRONIC PLUS may not detect vehicles travelling on a different line. The distance to the vehicle in front will be too short.

Other vehicles changing lane

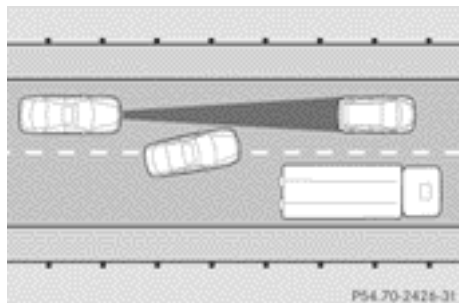

DISTRONIC PLUS has not detected the vehicle cutting in yet. The distance to this vehicle will be too short.

Narrow vehicles

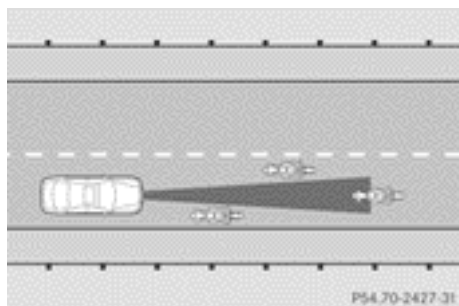

DISTRONIC PLUS has not yet detected the vehicle in front on the edge of the carriageway, because of its narrow width. The distance to the vehicle in front will be too short.

Obstructions and stationary vehicles

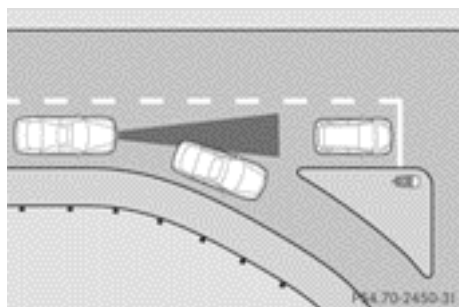

DISTRONIC PLUS does not brake for obstacles or stationary vehicles. If, for example, the

detected vehicle turns a corner and reveals an obstacle or stationary vehicle, DISTRONIC PLUS will not brake for these.

Crossing vehicles

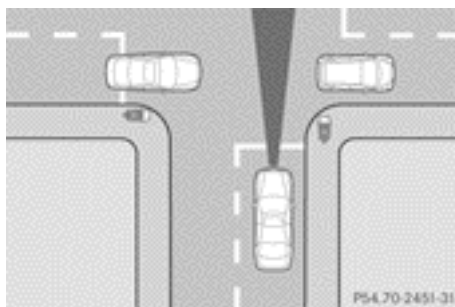

DISTRONIC PLUS may mistakenly detect vehicles that are crossing your lane. Activating DISTRONIC PLUS at traffic lights with crossing traffic, for example, could cause your vehicle to pull away unintentionally.

SPEEDTRONIC

Important safety notes

If you fail to adapt your driving style, SPEEDTRONIC can neither reduce the risk of accident nor override the laws of physics. SPEEDTRONIC cannot take into account road, weather or traffic conditions. SPEEDTRONIC is only an aid. You are responsible for the distance to the vehicle in front, for vehicle speed, for braking in good time, and for staying correctly in lane.

If there is a change of drivers, advise the new driver of the speed stored.

General notes

SPEEDTRONIC brakes automatically so that you do not exceed the set speed. On long and steep downhill gradients, especially if the vehicle is laden, you must select shift range **1, 2** or **3** in good time (▷ page 167). By doing so, you will make use of the braking effect of the engine. This relieves the load on the brake system and prevents the brakes from over-

heating and wearing too quickly. If you need additional braking, depress the brake pedal repeatedly rather than continuously.

You can set a variable or permanent limit speed:

- **variable** for speed limits, e.g. in built-up areas
- **permanent** for long-term speed restrictions, e.g. when driving with winter tyres fitted (> page 193)

i The speed indicated in the speedometer may differ slightly from the limit speed stored.

Variable SPEEDTRONIC

Cruise control lever

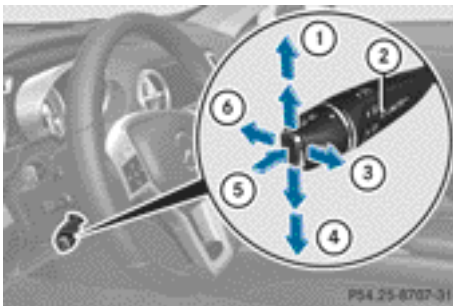

Cruise control lever

- ① To store the current speed or a higher speed
- ② LIM indicator lamp
- ③ To store the current speed and call up the last stored speed
- ④ To store the current speed or a lower speed
- ⑤ To switch between cruise control or DISTRONIC PLUS and variable SPEEDTRONIC
- ⑥ To deactivate variable SPEEDTRONIC

With the cruise control lever, you can operate cruise control or DISTRONIC PLUS and variable SPEEDTRONIC.

The LIM indicator lamp ② on the cruise control lever indicates which system you have selected:

- **LIM indicator lamp ② off:** cruise control or DISTRONIC PLUS is selected.
- **LIM indicator lamp ② on:** variable SPEEDTRONIC is selected.

You can use the cruise control lever to limit the speed to any speed above 30 km/h while the engine is running.

Selecting variable SPEEDTRONIC

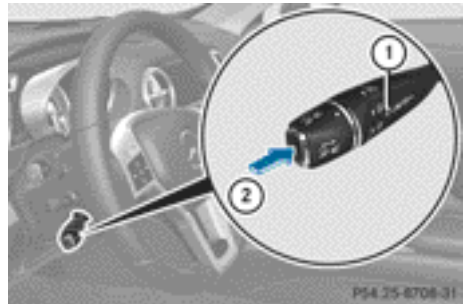

Cruise control lever

- ▶ Check whether LIM indicator lamp ① is on. If it is on, variable SPEEDTRONIC is already selected.
- If it is not, press the cruise control lever in the direction of arrow ②. LIM indicator lamp ① in the cruise control lever lights up. Variable SPEEDTRONIC is selected.

Storing the current speed



Cruise control lever

- ▶ Briefly press the cruise control lever up ① or down ②.
The current speed is stored. For five seconds, the multifunction display shows the stored speed, e.g. **Limit 100 km/h**.
Vehicles with cruise control: the stored speed is permanently displayed in the status indicator, e.g. **LIM 100 km/h**.
Vehicles with DISTRONIC PLUS: the segments from the start of the scale up to the stored speed light up in the speedometer.

You can use the cruise control lever to limit the speed to any speed above 30 km/h while the engine is running.

Storing the current speed and call up the last stored speed

WARNING

If you call up the stored speed and it is lower than the current speed, the vehicle decelerates. If you do not know the stored speed, the vehicle could decelerate unexpectedly. There is a risk of an accident.

Pay attention to the road and traffic conditions before calling up the stored speed. If you do not know the stored speed, store the desired speed again.

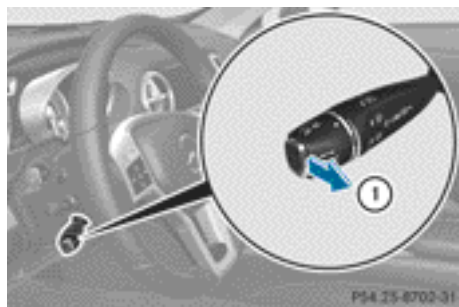

Cruise control lever

- ▶ Briefly pull the cruise control lever towards you ①.

Setting a speed

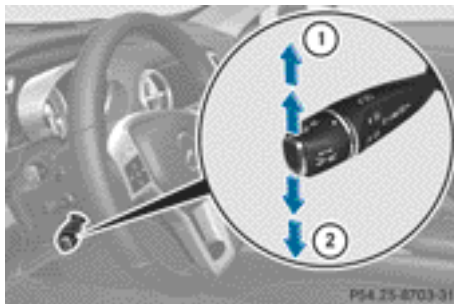

Cruise control lever

- ▶ **To adjust the set speed in 10 km/h increments:** briefly press the cruise control lever up ① past the pressure point for a higher speed, or down ② for a lower speed.

or

- ▶ Keep the cruise control lever pressed beyond the pressure point until the desired speed is set. Press the cruise control lever up ① for a higher speed or down ② for a lower speed.

- ▶ **To adjust the set speed in 1 km/h increments:** briefly press the cruise control lever up ① to the pressure point for a higher speed, or down ② for a lower speed.

or

- ▶ Keep the cruise control lever pressed to the pressure point until the desired speed is set. Press the cruise control lever up ① for a higher speed or down ② for a lower speed.

Deactivating variable SPEEDTRONIC

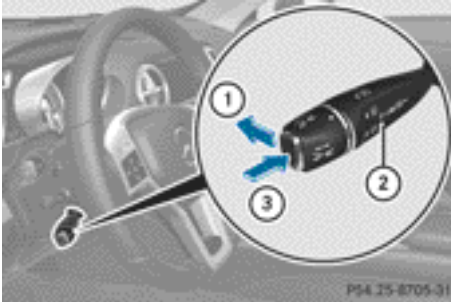

Cruise control lever

There are several ways to deactivate variable SPEEDTRONIC:

- ▶ Briefly press the cruise control lever forwards ①.

or

- ▶ Briefly press the cruise control lever in the direction of arrow ③.

LIM indicator lamp ② in the cruise control lever goes out. Variable SPEEDTRONIC is deactivated.

Cruise control or DISTRONIC PLUS is selected.

If you depress the accelerator pedal beyond the pressure point (kickdown), variable SPEEDTRONIC is automatically deactivated, but only if your current speed does not differ by more than 20 km/h from the stored speed. You will hear a warning tone if this is the case.

It is not possible to deactivate variable SPEEDTRONIC by braking.

- ❗ The last speed stored is cleared when you switch off the engine.

Permanent SPEEDTRONIC

You can use the on-board computer to limit the speed permanently to a value between 160 km/h (e.g. for driving on winter tyres) and the maximum speed (▷ page 236).

Shortly before the stored speed is reached, it appears in the multifunction display.

Permanent SPEEDTRONIC remains active, even if variable SPEEDTRONIC is deactivated.

You cannot exceed the stored limit speed, even if you depress the accelerator pedal beyond the pressure point (kickdown).

HOLD function

Important safety notes

⚠ WARNING

When leaving the vehicle, it can still roll away despite being braked by the HOLD function if:

- there is a malfunction in the system or in the voltage supply
- the HOLD function is deactivated by the accelerator pedal being depressed, e.g. by a vehicle occupant
- the electrical system in the engine compartment, the battery or the fuses are tampered with
- the battery is disconnected

There is a risk of an accident.

Before leaving the vehicle, always deactivate the HOLD function and secure the vehicle from rolling away.

❗ If DISTRONIC PLUS or the HOLD function is activated, the vehicle brakes automatically in certain situations. To prevent damage to the vehicle, deactivate DISTRONIC PLUS and the HOLD function in the following or other similar situations:

- when towing the vehicle
- in the car wash

Deactivate the HOLD function (▷ page 194).

General notes

The HOLD function can assist the driver in the following situations:

- when pulling away, especially on steep slopes
- when manoeuvring on steep slopes
- when waiting in traffic

The vehicle is kept stationary without the driver having to depress the brake pedal.

The braking effect is cancelled and the HOLD function is deactivated when you depress the accelerator pedal to pull away.

Activation conditions

You can activate the HOLD function if:

- the vehicle is stationary.
- the engine is running or if it has been automatically switched off by the ECO start/stop function.
- the driver's door is closed or if your seat belt is fastened.
- the electric parking brake is released.
- the transmission is in position **D**, **R** or **N**.
- DISTRONIC PLUS is deactivated.

Activating the HOLD function



- ▶ Make sure that the activation conditions are met.
 - ▶ Depress the brake pedal.
 - ▶ Quickly depress the brake pedal further until **HOLD** display ① appears in the multifunction display.
The HOLD function is activated. You can release the brake pedal.
- ① If depressing the brake pedal the first time does not activate the HOLD function, wait briefly and then try again.

Deactivating the HOLD function

The HOLD function is deactivated automatically if:

- you accelerate and the transmission is in position **D** or **R**.
- you shift the transmission to position **P**.

- you apply the brakes again with a certain amount of pressure until **HOLD** disappears from the multifunction display.
- you secure the vehicle using the electric parking brake.
- you activate DISTRONIC PLUS.

① After a time, the electric parking brake secures the vehicle and relieves the service brake.

The electric parking brake secures the vehicle automatically if the HOLD function is activated and:

- the driver's door is open and the driver's seat belt is unfastened.
- the engine is switched off, unless it is automatically switched off by the ECO start/stop function.
- a system fault occurs.
- the power supply is not sufficient.

If a fault occurs, then the transmission may also be shifted into position **P** automatically.

RACE START

Important safety notes

① Observe the safety notes for the SPORT handling mode (> page 76).

RACE START is intended solely for activation on dedicated race circuits.

RACE START enables optimum acceleration from a standing start. The precondition for this is a suitable high-grip road surface.

① RACE START is only available for the SL 63 AMG model.

Activation conditions

You can activate RACE START if:

- the doors are closed.
- the engine is running and it has reached an operating temperature of approximately 80 °C. This is the case when the engine oil

temperature in the multifunction display stops flashing.

- SPORT handling mode is activated (▷ page 76)
- the steering wheel is in the straight-ahead position
- the vehicle is stationary and the brake pedal is depressed (left foot)
- the transmission is in position **D**

Activating RACE START

- ▶ Depress the brake pedal with your left foot and keep it depressed.
- ▶ Turn the drive program selector clockwise (▷ page 165) until the **RS** lamp lights up. The multifunction display shows the **RACE START Confirm: Paddle UP Cancel: Paddle DOWN** message.

i If the activation conditions are no longer fulfilled, RACE START is cancelled. The multifunction display shows the **RACE START cancelled** message.

- ▶ To cancel: pull the left steering wheel shift paddle (▷ page 166).

or

- ▶ To confirm: pull the right steering wheel shift paddle (▷ page 166). The **RACE START available Depress accelerator** message appears in the multifunction display.

i If you do not depress the accelerator pedal fully within two seconds, RACE START is cancelled. The multifunction display shows the **RACE START not possible See Owner's Manual** message.

- ▶ Fully depress the accelerator pedal. The engine speed increases to at least 3,500 rpm.

The **RACE START Release brake to start** message appears in the multifunction display.

i If you do not release the brake pedal within five seconds, RACE START is cancel-

led. The multifunction display shows the **RACE START cancelled** message.

- ▶ Take your foot off the brake, but keep the accelerator pedal depressed. The vehicle pulls away at maximum acceleration.

The **RACE START active** message appears in the multifunction display.

RACE START is deactivated when the vehicle reaches a speed of approximately 50 km/h. Drive program **S+** is activated. SPORT handling mode remains activated.

RACE START is deactivated immediately if you release the accelerator pedal during RACE START or if any of the activation conditions are no longer fulfilled. The multifunction display shows the **RACE START not possible See Owner's Manual** message.

i After using it several times in short succession, RACE START will be unavailable until a certain distance has been driven.

Adaptive Damping System

General notes

The adjustable suspension system adapts to the particular driving conditions. Adjustment depends on your individual selection, i.e. sporty or comfortable. Your selection remains stored even if you remove the key from the ignition lock.

Selecting sports tuning

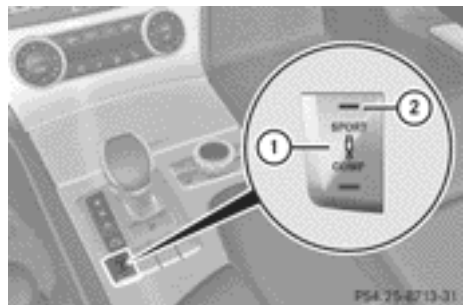

► Make sure that the engine is running or that it has been switched off by the ECO start/stop function.

► **If indicator lamp ② is not lit:** press button ①.

Indicator lamp ② lights up. You have selected the suspension for a sporty driving style.

The message **SPORT** appears in the multifunction display.

The firmer setting of the suspension tuning in sports mode ensures even better contact with the road. Select this mode if you want to experience direct contact with the road surface when employing a sporty driving style, e.g. on winding country roads.

Selecting comfort tuning

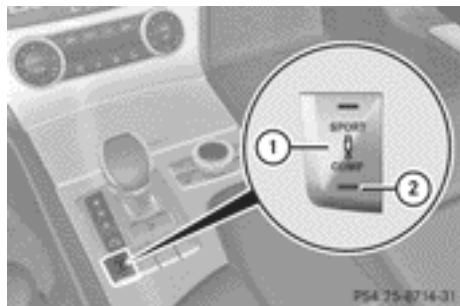

► Make sure that the engine is running or that it has been switched off by the ECO start/stop function.

► **If indicator lamp ② is not lit:** press button ①.

Indicator lamp ② lights up. You have selected the suspension for a comfortable driving style.

The message **COMFORT** appears in the multifunction display.

In comfort mode, the driving characteristics of your vehicle are more comfortable. Select this mode if you prefer a more comfortable driving style.

Active Body Control (except AMG vehicles)

Vehicle level

Important safety notes

WARNING

The vehicle is slightly lowered if you:

- have selected the SPORT suspension tuning at normal level and
- switch off the engine

Persons in the vicinity of the wheel arch or the underbody may thus become trapped. There is a risk of injury.

Make sure that nobody is in the vicinity of the wheel arch or the underbody when you switch off the engine.

! When the engine is switched off, the vehicle is lowered if SPORT suspension tuning has been selected at the normal level. The vehicle is automatically lowered by approximately 10 mm. Make sure when parking that you position your vehicle so that it does not make contact with the kerb as the vehicle is lowered. Your vehicle could otherwise be damaged.

In order to reduce fuel consumption and improve the driving dynamics, the vehicle is lowered as its speed increases. With the SPORT suspension tuning, it is lowered by up to 13 mm, with COMFORT by up to 5 mm. As the speed is reduced, the vehicle is raised up to the set vehicle height.

Select the "Normal" setting for normal road surfaces and "Raised" for driving with snow chains or on particularly poor road surfaces. Your selection remains stored even if you remove the key from the ignition lock.

Setting raised level

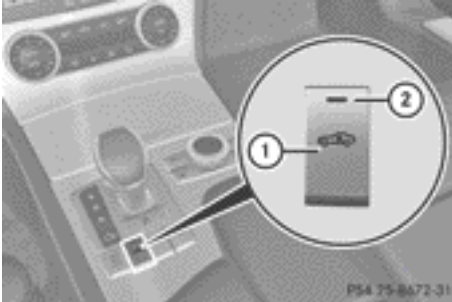

- ▶ Make sure that the engine is running or that it has been switched off by the ECO start/stop function.
- ▶ Make sure that a speed of 120 km/h is not exceeded.
- ▶ **If indicator lamp ② is not lit:** press button ①.

If the engine has been switched off by the ECO start/stop function, it is now restarted.

Indicator lamp ② lights up. The vehicle height is adjusted to raised level.

Setting the normal level

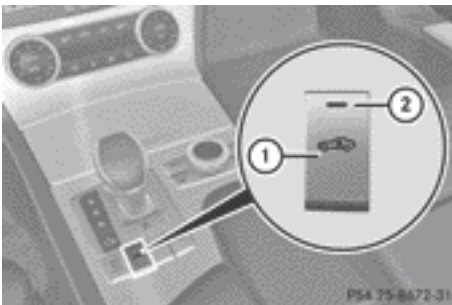

- ▶ Make sure that the engine is running or that it has been switched off by the ECO start/stop function.
- ▶ **If indicator lamp ② is lit:** press button ①.

Indicator lamp ② goes out. The vehicle is adjusted to normal level.

The "Raised level" setting is cancelled if you:

- are driving faster than approximately 120 km/h.
- drive for approximately three minutes at a speed over 80 km/h.

Suspension tuning

General notes

The electronically controlled ABC suspension system features improved driving dynamics and ride comfort.

The ABC suspension system is tuned individually to each wheel and depends on:

- the road surface condition, e.g. bumps
- the vehicle load
- your individual selection of the sporty or comfortable button

Your selection remains stored even if you remove the key from the ignition lock.

Selecting sports tuning

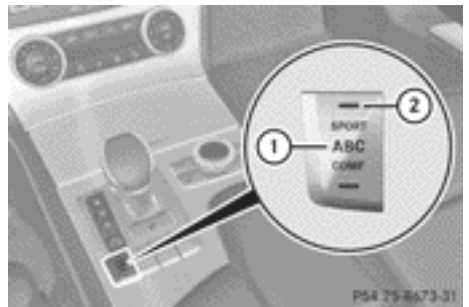

- ▶ Make sure that the engine is running or that it has been switched off by the ECO start/stop function.
 - ▶ **If indicator lamp ② is not lit:** press button ①.
- Indicator lamp ② lights up. You have selected the suspension for a sporty driving style.

The **ABC Active Body Control SPORT** message appears in the multifunction display.

The firmer suspension tuning in Sport mode ensures even better contact with the road. Select this mode if you prefer a firmer suspension tuning.

Selecting comfort tuning

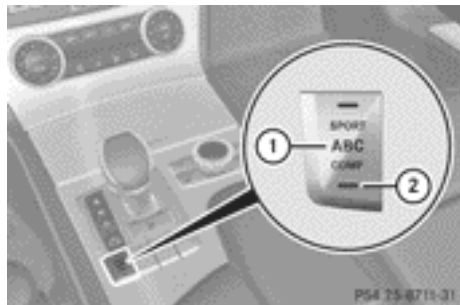

► Make sure that the engine is running or that it has been switched off by the ECO start/stop function.

► **If indicator lamp ② is not lit:** press button ①.

Indicator lamp ② lights up. You have selected the suspension for a comfortable driving style.

The **ABC Active Body Control COMFORT** message appears in the multifunction display.

In comfort mode, the driving characteristics of your vehicle are more comfortable. Select this mode if you prefer a more comfortable driving style.

Driving conditions menu in the COMAND display

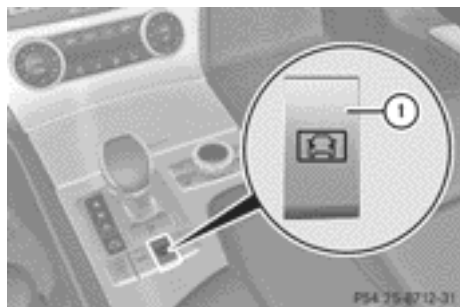

You can display some driving systems and additional information in the COMAND display.

- Make sure that the key is in position **2** in the ignition lock.
- Make sure COMAND Online is switched on (▷ page 293).
- Press button ①.
The corresponding displays appear in the COMAND display.

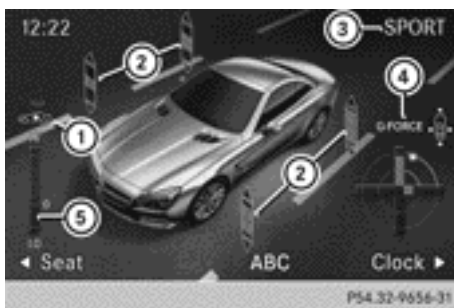

Example: displays in the COMAND display

- ① Selection of raised level (▷ page 196)
- ② Activity of ABC spring struts for roll and pitching support
- ③ Selected suspension tuning, i.e. sporty or comfortable (▷ page 197)
- ④ G-FORCE (longitudinal and lateral acceleration)
- ⑤ Current vehicle level

Active Body Control (AMG vehicles)

Vehicle level

Important safety notes

The vehicle is slightly lowered when the engine is switched off.

⚠ WARNING

People's limbs may become trapped if they are located underneath the vehicle or between the vehicle body and the tyres when the vehicle is lowering. There is a danger of injury.

When lowering the vehicle, make sure no one is underneath the vehicle or in the immediate vicinity of the wheel arches.

- !** If you have selected the normal level and switched the engine off, the vehicle is lowered. The vehicle is automatically lowered by approximately 10 mm. Make sure when parking that you position your vehicle so that it does not make contact with the kerb as the vehicle is lowered. Your vehicle could otherwise be damaged.

In order to reduce fuel consumption and improve the driving dynamics, the vehicle is lowered as its speed increases. With the SPORT suspension tuning, it is lowered by up to 13 mm, with COMFORT by up to 5 mm. As the speed is reduced, the vehicle is raised up to the set vehicle height.

Select the "Normal" setting for normal road surfaces and "Raised" for driving with snow chains or on particularly poor road surfaces.

Setting raised level



- ▶ Make sure that the engine is running or that it has been switched off by the ECO start/stop function.
- ▶ Make sure that a speed of 120 km/h is not exceeded.
- ▶ **If icon ② is not shown:** press ◀ or ▶ on the steering wheel to select the **Assist.** menu.
- ▶ Press the ▲ or ▼ button to select **Level.**

- ▶ Press the **OK** button.
The following message appears: **Raise Level with OK.**
- ▶ Press the **OK** button.
If the engine has been switched off by the ECO start/stop function, it is now restarted.
Icon ② appears. The vehicle height is adjusted to raised level.

Setting the normal level



- ▶ Make sure that the engine is running or that it has been switched off by the ECO start/stop function.
- ▶ **If icon ② is shown:** press ◀ or ▶ on the steering wheel to select the **Assist.** menu.
- ▶ Press the ▲ or ▼ button to select **Level.**
- ▶ Press the **OK** button.
The following message appears: **Lower Level with OK.**
- ▶ Press the **OK** button.
Icon ② is faded out. The vehicle is adjusted to normal level.

The "Raised level" setting is cancelled if you:

- are driving faster than approximately 120 km/h.
- drive for approximately three minutes at a speed over 80 km/h.

Suspension tuning

General notes

The electronically controlled ABC suspension system features improved driving dynamics and ride comfort.

The ABC suspension system is tuned individually to each wheel and depends on:

- the road surface condition, e.g. bumps
- the vehicle load
- your individual selection of the sporty or comfortable button

Selecting sports tuning

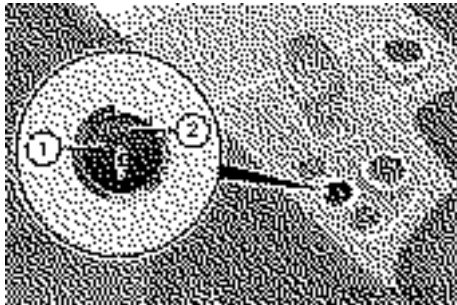

► Make sure that the engine is running or that it has been switched off by the ECO start/stop function.

► **If indicator lamp ② is not lit:** press button ①.

Indicator lamp ② lights up. You have selected the suspension for a sporty driving style.

The **AMG Ride Control SPORT** message appears in the multifunction display.

The firmer suspension tuning in Sport mode ensures even better contact with the road. Select this mode if you prefer a firmer suspension tuning.

Selecting comfort tuning

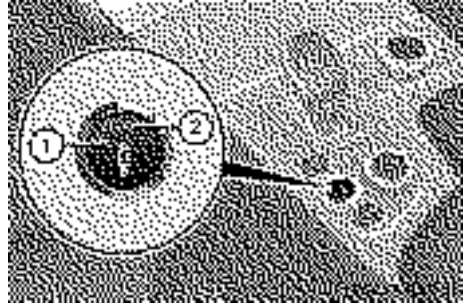

► Make sure that the engine is running or that it has been switched off by the ECO start/stop function.

► **If indicator lamp ② is lit:** press button ①.

Indicator lamp ② goes out. You have selected the suspension for a comfortable driving style.

The **AMG Ride Control COMFORT** message appears in the multifunction display.

In comfort mode, the driving characteristics of your vehicle are more comfortable. Select this mode if you prefer a more comfortable driving style.

Driving conditions menu in the COMAND display

You can display some driving systems and additional information in the COMAND display.

► Call up the driving conditions menu in the COMAND display (► page 310).

The corresponding displays appear in the COMAND display.

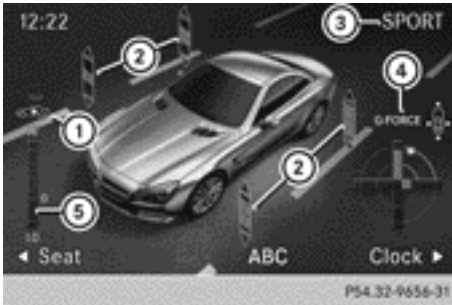

Example: displays in the COMAND display

- ① Selection of raised level (▷ page 198)
- ② Activity of ABC spring struts for roll and pitching support
- ③ Selected suspension tuning, i.e. sporty or comfortable (▷ page 200)
- ④ G-FORCE (longitudinal and lateral acceleration)
- ⑤ Current vehicle level

PARKTRONIC

Important safety notes

PARKTRONIC is an electronic parking aid with ultrasonic sensors. It indicates visually and audibly the distance between your vehicle and an object.

PARKTRONIC is only an aid. It is not a substitute for your attention to the immediate surroundings. The responsibility for safe manoeuvring and parking remains with you. Make sure that there are no persons, animals or objects in range while manoeuvring and parking.

! When parking, pay particular attention to objects above or below the sensors, such as flower pots or trailer drawbars. PARKTRONIC does not detect such objects when they are in the immediate vicinity of the vehicle. You could damage the vehicle or the objects.

The sensors may not detect snow and objects which absorb ultrasonic sources.

Ultrasonic sources, such as an automatic car wash, a lorry's compressed-air brakes or a pneumatic drill, could cause PARKTRONIC to malfunction.

PARKTRONIC may not function correctly on uneven terrain.

PARKTRONIC is activated automatically if you:

- switch on the ignition
- shift the transmission to position **D**, **R** or **N**
- release the electric parking brake

PARKTRONIC is deactivated at speeds above 18 km/h. It is reactivated at lower speeds.

PARKTRONIC monitors the area around your vehicle using six sensors in the front bumper and four sensors in the rear bumper.

Range of the sensors

General notes

PARKTRONIC does not take into account obstacles located:

- below the detection range, e.g. persons, animals or objects
- above the detection range, e.g. overhanging loads, tail sections or loading ramps of goods vehicles

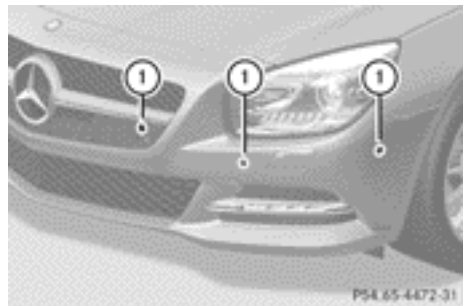

- ① Example: sensors in the front bumper, left-hand side

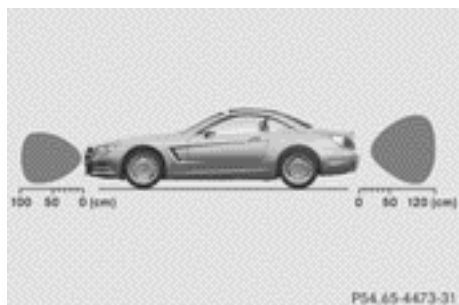

Side view

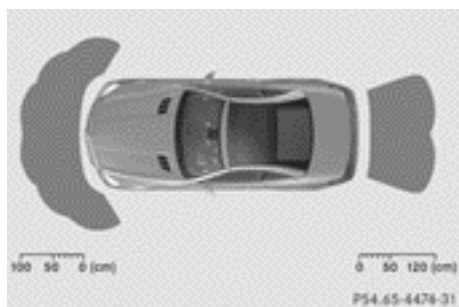

Top view

The sensors must be free of dirt, ice and slush. Otherwise, they may not function correctly. Clean the sensors regularly, taking care not to scratch or damage them (▷ page 539).

Front sensors

Centre	Approx. 100 cm
Corners	Approx. 60 cm

Rear sensors

Centre	Approx. 120 cm
Corners	Approx. 80 cm

Minimum distance

Centre	Approx. 20 cm
Corners	Approx. 15 cm

If there is an obstacle within this range, the relevant warning displays light up and a warning tone sounds. If the distance falls below

the minimum, the distance may no longer be shown.

Warning displays



Warning display for the front area

- ① Segments on the left-hand side of the vehicle
- ② Segments on the right-hand side of the vehicle
- ③ Segments showing operational readiness

The warning displays show the distance between the sensors and the obstacle. The warning display for the front area is located on the dashboard above the centre air vents. The warning display for the rear area is located on the cover behind the seats in the rear compartment.

The warning display for each side of the vehicle is divided into five yellow and two red segments. PARKTRONIC is operational if yellow segments showing operational readiness ③ light up.

The selected transmission position and the direction in which the vehicle is rolling determine which warning display is active when the engine is running.

Transmission position	Warning display
D	Front area activated
R, N or the vehicle is rolling backwards	Rear and front areas activated
P	No areas activated

One or more segments light up as the vehicle approaches an obstacle, depending on the vehicle's distance from the obstacle.

- **Front area:** following the sixth segment, you will hear an intermittent warning tone. From the seventh segment, you will hear a continuous warning tone for approximately two seconds. This indicates that you have now reached the minimum distance.
- **Rear area:** from the first segment onwards, you will hear an intermittent warning tone. The interval gets shorter after each segment. At the seventh segment, you will hear a continuous warning tone for approximately two seconds. This indicates that you have now reached the minimum distance.

Deactivating/activating PARKTRONIC

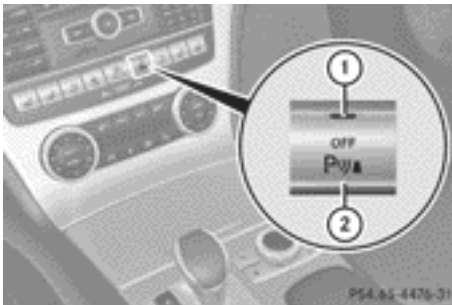

- ① Indicator lamp
- ② Deactivating/activating PARKTRONIC

If indicator lamp ① lights up, PARKTRONIC is deactivated. Active Park Assist is then also deactivated.

- **i** PARKTRONIC is automatically activated when you turn the key to position 2 in the ignition lock.

Problems with PARKTRONIC

Problem	Possible causes/consequences and ► Solutions
<p>Only the red segments in the PARKTRONIC warning displays are lit. You also hear a warning tone for approximately two seconds.</p> <p>PARKTRONIC is deactivated after approximately five seconds, and the indicator lamp in the PARKTRONIC button lights up.</p>	<p>PARKTRONIC has malfunctioned and has switched off.</p> <p>► If problems persist, have PARKTRONIC checked at a qualified specialist workshop.</p>
<p>Only the red segments in the PARKTRONIC warning displays are lit. PARKTRONIC is deactivated after approximately five seconds.</p>	<p>The PARKTRONIC sensors are dirty or there is interference.</p> <p>► Clean the PARKTRONIC sensors (► page 539).</p> <p>► Switch the ignition back on.</p>
	<p>The problem may be caused by an external source of radio or ultrasound waves.</p> <p>► See if PARKTRONIC functions in a different location.</p>

Active Parking Assist

Important safety notes

Active Parking Assist is only an aid. It is not a substitute for paying attention to your immediate surroundings. You are always responsible for safe manoeuvring and parking. When parking or manoeuvring, make sure that no persons, animals or objects are in the area in which you are manoeuvring.

WARNING

The vehicle will veer out when parking and can take you onto sections of the oncoming lane. As a result, you may collide with other road users. There is a risk of an accident.

When parking, pay attention to other road users. Stop the vehicle if necessary or cancel the Active Parking Assist parking procedure.

! If unavoidable, you should drive over obstacles such as kerbs slowly and not at a sharp angle. Otherwise, you may damage the wheels or tyres.

Active Parking Assist may sometimes recommend parking spaces that are not suitable for parking, e.g.:

- in a zone where parking or stopping is prohibited
- in front of curves or entrances and exits
- on unsuitable surfaces

Parking tips:

- on narrow roads, drive as closely as possible past the parking space.
- parking spaces that are littered, overgrown or partially occupied by trailer drawbars might be identified incorrectly or not at all.
- snowfall or heavy rain may lead to a parking space being measured inaccurately.

- pay attention to the PARKTRONIC (▷ page 202) warning messages during the parking procedure.
- at any time, you can intervene in the steering procedure to correct it. Active Parking Assist will then be cancelled.
- when transporting a load which protrudes from your vehicle, you should not use Active Parking Assist.
- never use Active Parking Assist when snow chains are fitted.
- make sure that the tyre pressures are always correct. This has a direct influence on the parking characteristics of the vehicle.

General notes

Active Parking Assist is an electronic parking aid with ultrasound. Ultrasound is used to measure the road on both sides of the vehicle. A suitable parking space is indicated by the parking symbol. Active steering intervention can assist you during parking.

You may also use PARKTRONIC (▷ page 201). When PARKTRONIC is switched off, Active Parking Assist is also unavailable. Use Active Parking Assist for parking spaces:

- that are parallel to the direction of travel
- that are on straight roads, not bends
- that are on the same level as the road, e.g. not on the pavement

Parking

Important safety notes

Objects located above the height range of Active Parking Assist will not be detected when the parking space is measured. These are not taken into account when the parking procedure is calculated, e.g. overhanging loads, tail sections or loading ramps of goods vehicles. In some circumstances, Active Parking Assist may therefore guide you into the parking space too early.

WARNING

If objects are located above the detection range, Active Parking Assist may start to steer into the parking space too soon. As a result, you could cause a collision. There is a risk of an accident.

If objects are located above the detection range, stop the vehicle and switch Active Parking Assist off.

WARNING

Active Parking Assist merely aids you by intervening actively in the steering. There is a risk of accident if you do not apply the brakes yourself.

Always apply the brakes yourself when parking and manoeuvring.

Detecting parking spaces



Example: detected parking space

Active Parking Assist is switched on automatically when driving forwards. The system is operational at speeds of up to approximately 35 km/h. While in operation, the system independently locates and measures parking spaces on both sides of the vehicle. When driving at speeds below 30 km/h, you will see parking symbol ② as a status indicator in the instrument cluster. When a parking space has been detected, an arrow towards the right ③ or the left ① also appears.

Active Parking Assist only displays parking spaces on the front-passenger side as standard. Parking spaces on the driver's side are displayed as soon as the turn signal on the driver's side is activated. If you wish to park in a space on the driver's side, the turn signal on the driver's side must remain on. The turn signal must remain switched on until you

acknowledge the use of Active Parking Assist by pressing the  button on the multifunction steering wheel.

Active Parking Assist will only detect parking spaces:

- that are parallel to the direction of travel
- that are at least 1.5 m wide
- that are at least 1.0 m longer than your vehicle

A parking space is displayed while you are driving past it, and until you are approximately 15 m away from it.

Reversing into the parking space

► Stop the vehicle when the parking symbol shows the desired parking space in the instrument cluster.

► Shift the transmission to position **R**.

The **Start Park Assist? Yes: OK No:**

 message appears in the multifunction display.

► **To cancel the procedure:** press the  button on the multifunction steering wheel or pull away.

or

► **To park using Active Parking Assist:** press the  button on the multifunction steering wheel.

The **Park Assist active Accelerate and brake Observe surroundings** message appears in the multifunction display.

- Release the multifunction steering wheel.
- Reverse the vehicle, being ready to brake at all times. Do not exceed a maximum speed of approximately 10 km/h when reversing. Otherwise, Active Parking Assist will be cancelled.

i When parking in tight spaces, you will achieve the best results by backing up as far as possible. When doing so, also observe the PARKTRONIC messages.

► Stop as soon as PARKTRONIC sounds the continuous warning tone, if not before. Additional manoeuvring may be required in tight parking spaces.

The **Park Assist active Select D Observe surroundings** message appears in the multifunction display.

► Shift the transmission to position **D** while the vehicle is stationary. Active Parking Assist immediately steers in the other direction.

The **Park Assist active Accelerate and brake Observe surroundings** message appears in the multifunction display.

i You will achieve the best results by waiting for the steering procedure to complete before pulling away.

► Drive forwards and be ready to brake at all times.

► Stop as soon as PARKTRONIC sounds the continuous warning tone, if not before.

The Park Assist active Select R

Observe surroundings message appears in the multifunction display.

► Drive forwards and reverse according to the information shown in the multifunction display.

As soon as the parking procedure is complete, the **Park Assist switched off** message appears in the multifunction display. PARKTRONIC continues to be available.

► Manoeuvre if necessary.

► Always observe the warning messages displayed by PARKTRONIC (▷ page 202).

Parking tips:



- on narrow roads, drive as closely as possible past the parking space.
- parking spaces that are littered, overgrown or partially occupied by trailer drawbars might be identified incorrectly or not at all.
- snowfall or heavy rain may lead to a parking space being measured inaccurately.
- the way your vehicle is positioned in the parking space after parking is dependent on various factors. These include the position and shape of the vehicles parked in front and behind it and the conditions of the location. In some cases, Active Parking

Assist may guide you too far into a parking space, or not far enough into it. In some cases, it may also lead you across or onto the kerb. If necessary, you should cancel the parking procedure with Active Parking Assist.

- you can also engage forward gear prematurely. The vehicle redirects and does not drive as far into the parking space. Should a gear be changed too early, the parking procedure will be cancelled. A sensible parking position can no longer be achieved from this position.

Exiting a parking space

Active Parking Assist can only assist you with exiting a parking space if you have parked the vehicle using Active Parking Assist.

- ▶ Start the engine.
- ▶ Switch on the turn signal on the side facing the street.
- ▶ Shift the transmission to position **D** or **R**. The **Start Park Assist? Yes: OK No: ** message appears in the multifunction display.
- ▶ **To cancel the procedure:** press the  button on the multifunction steering wheel or pull away.

or

- ▶ **To exit a parking space using Active Parking Assist:** press the  button on the multifunction steering wheel. The **Park Assist active Accelerate and brake Observe surroundings** message appears in the multifunction display.
- ▶ Release the multifunction steering wheel.
- ▶ Reverse the vehicle or drive forwards, being ready to brake at all times. Do not exceed a maximum speed of approximately 10 km/h when exiting a parking space. Otherwise, Active Parking Assist will be cancelled.
- ▶ Stop as soon as PARKTRONIC sounds the continuous warning tone, if not before.

- ▶ Shift the transmission to position **D** or **R** as required while the vehicle is stationary. Active Parking Assist immediately steers in the other direction.

i You will achieve the best results by waiting for the steering procedure to complete before pulling away.

If you reverse after activation, the steering wheel is moved to the straight-ahead position.

- ▶ Drive forwards or reverse the vehicle, being ready to brake at all times.
- ▶ Stop as soon as PARKTRONIC sounds the continuous warning tone, if not before.
- ▶ Drive forwards and reverse as instructed by the PARKTRONIC warning displays.

Once you have exited the parking space completely, the steering wheel is moved to the straight-ahead position. You hear a tone and the message **Park Assist switched off** appears in the multifunction display. You will then have to steer and merge into traffic on your own. PARKTRONIC is still available.

Cancelling Active Parking Assist

You can cancel Active Parking Assist at any time.

- ▶ Stop the movement of the multifunction steering wheel or steer yourself. Active Parking Assist will be cancelled at once. The **Park Assist cancelled** message appears in the multifunction display.

or

- ▶ Press the PARKTRONIC button on the centre console (▷ page 203). PARKTRONIC is switched off and Active Parking Assist is immediately cancelled. The **Park Assist cancelled** message appears in the multifunction display.

Active Parking Assist is cancelled automatically if:

- parking using Active Parking Assist is no longer possible.
- you are driving faster than 10 km/h.
- a wheel spins and ESP® intervenes or fails. The  ESP warning lamp lights up in the instrument cluster.

A warning tone sounds. The parking space symbol disappears and the multifunction display shows the **Park Assist cancelled** message.

When Active Parking Assist is cancelled, you must steer against yourself.

Reversing camera

Important safety notes

The reversing camera is only an aid. It is not a substitute for your attention to the immediate surroundings. The responsibility for safe manoeuvring and parking remains with you. Make sure that there are no persons, animals or objects in range while manoeuvring and parking.

Under the following circumstances, the reversing camera will not function, or will function in a limited manner:

- if the tailgate is open
- in heavy rain, snow or fog
- at night or in very dark places
- if the camera is exposed to very bright light
- if the area is lit by fluorescent light or LED lighting (the display may flicker)
- if there is a sudden change in temperature, e.g. when driving into a heated garage in winter
- if the camera lens is dirty or obstructed
- if the rear of your vehicle is damaged. In this event, have the camera position and setting checked at a qualified specialist workshop.

General notes

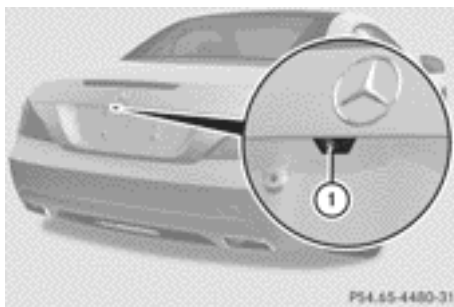

Reversing camera ① is in the boot lid handle.

Reversing camera ① is an optical parking and manoeuvring aid. It shows the area behind your vehicle with guide lines in the COMAND display.

The area behind the vehicle is displayed as a mirror image, as in the rear-view mirror.

i The text of messages shown in the COMAND display depends on the language setting. The following are examples of reversing camera messages in the COMAND display.

Activating/deactivating the reversing camera

- ▶ **To activate:** make sure that the key is in position **2** in the ignition lock.
- ▶ Make sure that the function "show reversing camera display" is selected in COMAND Online (▷ page 314).
- ▶ Engage reverse gear. The area behind the vehicle is shown with guide lines in the COMAND display.

To deactivate: the reversing camera is deactivated if you:

- shift the transmission to position **P**
- drive forwards 10 m
- shift the transmission from **R** to another position (after 15 seconds)
- drive forwards at a speed of over 10 km/h

Displays in the COMAND display

The reversing camera may show a distorted view of obstacles, show them incorrectly or not at all. Obstacles are not shown by the reversing camera in the following locations:

- very close to the rear bumper
- under the rear bumper
- in the area immediately above the tailgate handle

! Objects not at ground level may appear to be further away than they actually are, e.g.:

- the bumper of a parked vehicle
- the drawbar of a trailer
- the ball coupling of a trailer tow hitch
- the rear section of an HGV
- a slanted post

Use the guidelines only for orientation.

Approach objects no further than the bottom-most guideline.

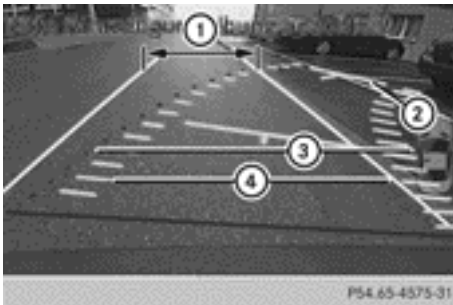

- ① White guide line without turning the steering wheel, vehicle width including the exterior mirrors (static)
- ② Yellow guide line at a distance of approximately 4.0 m from the rear of the vehicle
- ③ Red guide line for the vehicle width including the exterior mirrors, for current steering wheel angle (dynamic)
- ④ Yellow lane marking the course the tyres will take at the current steering wheel angle (dynamic)

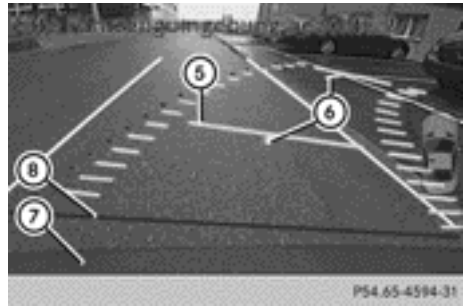

- ⑤ Yellow guide line at a distance of approximately 1.0 m from the rear of the vehicle
- ⑥ Vehicle centre axle (marker assistance)
- ⑦ Bumper
- ⑧ Red guide line at a distance of approximately 0.25 m from the rear of the vehicle

The guide lines are shown when the transmission is in position **R**.

The distance specifications only apply to objects that are at ground level.

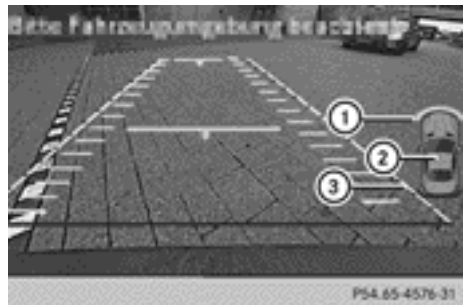

Additional messages for vehicles with PARKTRONIC

- ① Front warning display
- ② Additional PARKTRONIC operational readiness indicator
- ③ Rear warning display

Vehicles with PARKTRONIC: when PARKTRONIC is operational (▷ page 202), additional operational readiness indicator ② appears in the COMAND display. If the PARKTRONIC warning displays are active or light up, the warning displays ① and ③ are also active or light up correspondingly in the COMAND display.

Reverse parking function

Reversing straight into a parking space without turning the steering wheel

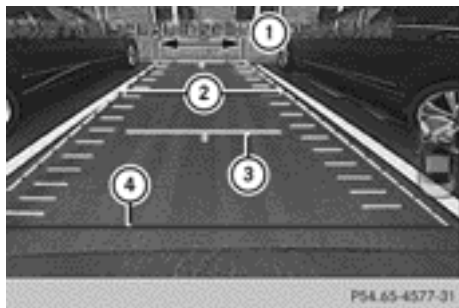

- ① White guide line without turning the steering wheel, vehicle width including the exterior mirrors (static)
 - ② Red guide line for the vehicle width including the exterior mirrors, for current steering wheel angle (dynamic)
 - ③ Yellow guide line at a distance of approximately 1.0 m from the rear of the vehicle
 - ④ Red guide line at a distance of approximately 0.25 m from the rear of the vehicle
- ▶ Make sure that the reversing camera is switched on (▷ page 208). The lane and the guide lines are shown.
 - ▶ With the help of white guide line ①, check whether the vehicle will fit into the parking space.
 - ▶ Using white guide line ① as a guide, carefully reverse until you reach the end position. Red guide line ④ is then at the end of the parking space. The vehicle is almost parallel in the parking space.

Reverse perpendicular parking with the steering wheel at an angle



Turning the steering wheel

- ① Red guide line for the vehicle width including the exterior mirrors, for current steering wheel angle (dynamic)
 - ② Parking space marking
- ▶ Make sure that the reversing camera is switched on (▷ page 208). The lane and the guide lines are shown.
 - ▶ Drive past the parking space and bring the vehicle to a standstill.
 - ▶ While the vehicle is at a standstill, turn the steering wheel in the direction of the parking space until red guide line ① reaches parking space marking ②.
 - ▶ Keep the steering wheel in that position and reverse carefully.



Reversing with the steering wheel turned

- ① Red guide line for the vehicle width including the exterior mirrors, for current steering wheel angle (dynamic)

- ▶ Stop the vehicle when it is almost exactly in front of the parking space.
The white lane should be as close to parallel with the parking space marking as possible.

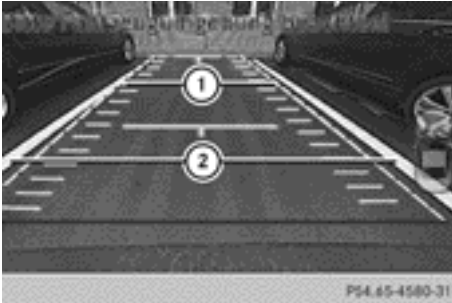

Driving to the final position

- ① White guide line at current steering wheel angle
 - ② Parking space marking
- ▶ Turn the steering wheel to the centre position while the vehicle is stationary.

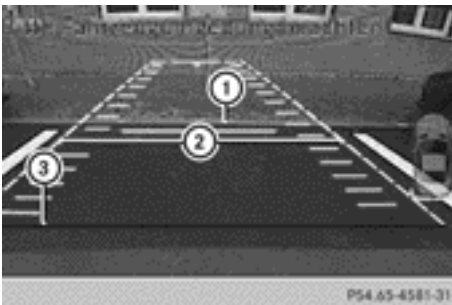

- ① End of parking space
 - ② White guide line without turning the steering wheel
 - ③ Red guide line at a distance of approximately 0.25 m from the rear of the vehicle
- ▶ Reverse carefully until you have reached the end position.
Red guide line ③ is then at end of parking space ①. The vehicle is almost parallel in the parking space.

ATTENTION ASSIST

Important safety notes

ATTENTION ASSIST is only an aid. It cannot always detect fatigue or lapses in concentration until too late or not at all. The system is not a substitute for a well-rested and attentive driver.

ATTENTION ASSIST helps you during long, monotonous journeys such as on motorways and trunk roads. It is active in the 80 km/h to 180 km/h range.

If ATTENTION ASSIST detects typical indicators of fatigue or increasing lapses in concentration on the part of the driver, it suggests taking a break.

ATTENTION ASSIST assesses your level of fatigue or lapses in concentration by taking the following criteria into account:

- your personal driving style, e.g. steering characteristics
- journey-related parameters, e.g. time of day, length of journey

The functionality of ATTENTION ASSIST is restricted, and warnings may be delayed or not occur at all:

- if the road condition is poor, e.g. if the surface is uneven or if there are potholes
- if there is a strong side wind
- if you have adopted a sporty driving style with high cornering speeds or high rates of acceleration
- if you are predominantly driving slower than 80 km/h or faster than 180 km/h
- if you are currently using COMAND Online or making a telephone call with it
- if the time has been set incorrectly
- in active driving situations, such as when you change lanes or change your speed

Warning and display messages in the multifunction display

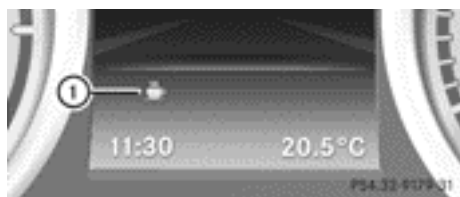

- ▶ Activate ATTENTION ASSIST using the on-board computer (▷ page 232). Symbol ① appears in the multifunction display.
- ▶ **The Attention Assist: Take a break! message appears in the multifunction display.** If necessary, take a break.
- ▶ Press the or button to confirm the message.

If ATTENTION ASSIST is active, you will be warned no sooner than 20 minutes after your journey has begun. In addition to the message shown in the multifunction display, you will then hear an intermittent warning tone twice.

On long journeys, take regular breaks in good time to allow yourself to rest properly. If you do not take a break and ATTENTION ASSIST still detects increasing lapses in concentration, you will be warned again after 15 minutes at the earliest.

ATTENTION ASSIST is reset and starts assessing your tiredness again when you continue your journey if:

- you switch off the engine
- you take off your seat belt and open the driver's door, e.g. for a change of drivers or to take a break

Speed Limit Assist

Important safety notes

Speed Limit Assist is only an aid and does not always detect traffic signs specifying the maximum permissible speed. Traffic signs

always have priority over the Speed Limit Assist display.

The system may be impaired or may not function if:

- there is poor visibility, e.g. due to snow, rain, fog or spray
- there is glare, e.g. from the sun or from oncoming traffic
- the windscreen is dirty, misted up or covered, for instance by a sticker, in the vicinity of the camera
- the traffic signs are covered, for instance by dirt, snow or trees
- the traffic signs are poorly illuminated
- there are ambiguous traffic signs, for instance near roadworks or on multi-lane roads

General notes

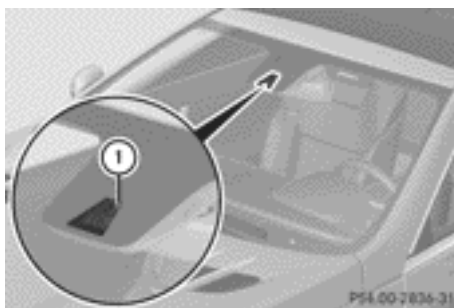

Speed Limit Assist detects the traffic signs with camera ① attached at the top of the windscreen.

i Speed Limit Assist is not operational in all countries.

Speed Limit Assist shows you detected speed limits in the multifunction display. Data from the navigation system is also used for this purpose. The display appears if Speed Limit Assist detects a traffic sign indicating a speed limit or the end of a speed limit. If Speed Limit Assist does not detect any traffic signs, the speed limit from the digital road map is taken and shown in the display.

Information in the multifunction display

Briefly showing detected traffic signs

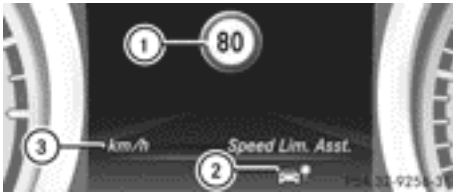

- ① Traffic sign indicating a speed limit or the end of a speed limit
 - ② Speed Limit Assist is available and the warning function is switched on in the on-board computer
 - ③ Units used in the traffic sign displayed
- Activate the Speed Limit Assist warning function using the on-board computer (▷ page 231).
Symbol ② appears.

When you activate the Speed Limit Assist warning function, a traffic sign indicating the speed limit or end of speed limit zone ① may appear in the multifunction display. The traffic sign appears for approximately five seconds as soon as it is detected. Any other information in the multifunction display is hidden for this period.

Permanently showing detected traffic signs

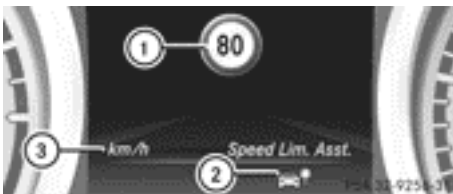

- ① Traffic sign indicating a speed limit or the end of a speed limit
 - ② Speed Limit Assist is available and the warning function is switched on in the on-board computer
 - ③ Units used in the traffic sign displayed
- Display Speed Limit Assist using the on-board computer (▷ page 231).

If Speed Limit Assist is selected in the on-board computer, a traffic sign indicating the speed limit or end of a speed limit zone ① appears in the multifunction display as soon as it is detected.

Traffic sign indicating a speed limit ① is generally displayed until:

- a traffic sign indicating the end of the speed limit is detected.
- you make a turn.
- you leave or enter a town.
- the road type changes (e.g. motorway, country road).
- you have travelled a certain minimum distance without the traffic sign being repeated or detected again.

i You can also activate Speed Limit Assist using COMAND Online; see the separate COMAND Online operating instructions. The maximum permissible speed is shown in the COMAND display.

Active Driving Assistance package

General notes

The Active Driving Assistance package consists of DISTRONIC PLUS (▷ page 181), Active Blind Spot Assist (▷ page 213) and Active Lane Keeping Assist (▷ page 216).

Active Blind Spot Assist

Important safety notes

Active Blind Spot Assist is only an aid. It may fail to detect some vehicles and is no substitute for attentive driving.

⚠ WARNING

Active Blind Spot Assist does not react to:

- vehicles overtaken too closely on the side, placing them in the blind spot area
- vehicles approaching and driving by with a speed difference of more than approximately 11 km/h

In such situations, Active Blind Spot Assist cannot warn you or intervene. There is a risk of an accident.

Always observe the traffic conditions carefully, and maintain a safe lateral distance.

General notes

Active Blind Spot Assist uses a radar sensor system to monitor the area to the sides of your vehicle which are behind the driver. A warning display in the exterior mirrors draws your attention to vehicles detected in the monitored area. If you then switch on the corresponding turn signal to change lane, you will also receive an optical and audible collision warning. If a risk of lateral collision is detected, corrective braking may help you avoid a collision. To support the course-correcting brake application, Active Blind Spot Assist also uses the forward-facing radar sensor system.

Active Blind Spot Assist supports you from a speed of approximately 30 km/h.

For Active Blind Spot Assist to assist you when driving, the radar sensor system must be:

- activated (▷ page 237)
- operational

i In some countries you must deactivate the radar sensor system (▷ page 237).

For further information about the radar sensor system; see (▷ page 595).

Monitoring range

In particular, the detection of obstacles can be impaired if there is:

- dirt on the sensors or anything else covering the sensors
- poor visibility, e.g. due to fog, heavy rain or snow
- a narrow vehicle travelling in front, e.g. a motorcycle or a bicycle
- very wide lanes
- narrow lanes

- vehicles not driving in the middle of their lane
- barriers or other road boundaries

Vehicles in the monitoring range are then not indicated.

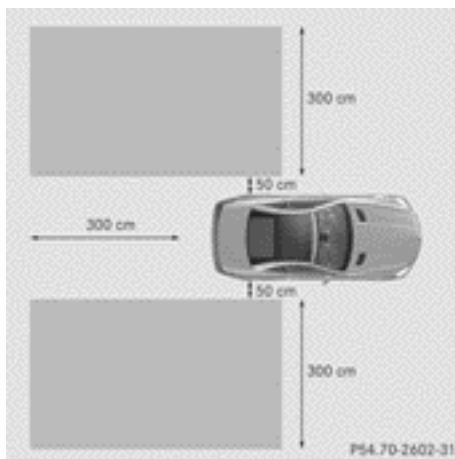

Active Blind Spot Assist monitors the area up to 3.0 m behind your vehicle and directly next to your vehicle, as shown in the diagram. For this purpose, Active Blind Spot Assist uses radar sensors in the rear bumper.

If the lanes are narrow, vehicles driving in the lane beyond the lane next to your vehicle may be indicated, especially if the vehicles are not driving in the middle of their lane. This may be the case if there are vehicles at the edge of their lane nearest your vehicle.

Due to the nature of the system:

- warnings may be issued in error when driving close to crash barriers or similar solid lane borders.
- warnings may be interrupted when driving alongside particularly long vehicles, for example lorries, for a prolonged time.

Two Active Blind Spot Assist radar sensors are integrated into the front and rear bumpers respectively. An additional radar sensor is located behind the cover in the radiator grille. Make sure that the bumpers and the cover in the radiator grille are free of dirt, ice or slush. The rear sensors must not be covered, e.g. by

bicycle racks or overhanging loads. Following a severe impact or in the event of damage to the bumpers, have the function of the radar sensors checked at a qualified specialist workshop. Active Blind Spot Assist may otherwise no longer work properly.

Indicator and warning display

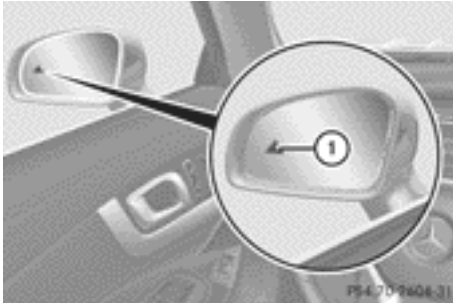

① Yellow indicator lamp/red warning lamp

Active Blind Spot Assist is not active at speeds below approximately 30 km/h. Vehicles in the monitoring range are then not indicated.

When Active Blind Spot Assist is activated, indicator lamp ① in the exterior mirrors lights up yellow at speeds of up to 30 km/h. At speeds above 30 km/h, the indicator lamp goes out and Active Blind Spot Assist is operational.

If a vehicle is detected within the monitoring range of Blind Spot Assist at speeds above 30 km/h, warning lamp ① on the corresponding side lights up red. This warning is always occurs when a vehicle enters the blind spot monitoring range from behind or from the side. When you overtake a vehicle, the warning only occurs if the difference in speed is less than 12 km/h.

The yellow indicator lamp goes out if reverse gear is engaged. Active Blind Spot Assist is then no longer active.

The brightness of the indicator/warning lamps is adjusted automatically according to the ambient light.

Visual and acoustic collision warning

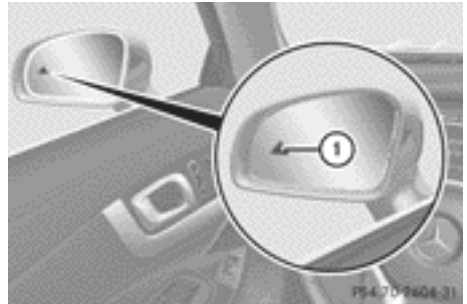

When you switch on the turn signals to change lanes and a vehicle is detected in the side monitoring range, you receive a visual and acoustic collision warning. You then hear a double warning tone and red warning lamp ① flashes. If the turn signal remains on, detected vehicles are indicated by the flashing of red warning lamp ①. There are no further warning tones.

Course-correcting brake application

⚠ WARNING

A course-correcting brake application cannot always prevent a collision. There is a risk of an accident.

Always steer, brake or accelerate yourself, especially if Active Blind Spot Assist warns you or makes a course-correcting brake application. Always maintain a safe distance at the sides.

⚠ WARNING

Active Blind Spot Assist does not detect all traffic situations and road users. In very rare cases, the system may make an inappropriate brake application. There is a risk of an accident.

An inappropriate brake application may be interrupted at any time if you steer slightly in the opposite direction or accelerate. Always make sure that there is sufficient distance to the side for other traffic or obstacles.



If a course-correcting brake application occurs, red warning lamp ① flashes in the exterior mirror and a dual warning tone sounds. In addition, display ② appears in the multifunction display.

If Active Blind Spot Assist detects a risk of a lateral collision in the monitoring range, a course-correcting brake application is carried out. This is designed to help you avoid a collision.

The course-correcting brake application is available in the speed range between 30 km/h and 200 km/h.

Either a very slight course-correcting brake application, or none at all, may occur if:

- there are vehicles or obstacles, e.g. crash barriers, on both sides of your vehicle
- a vehicle approaches too closely on the side
- you have adopted a sporty driving style with high cornering speeds
- you brake or accelerate decisively
- a driving safety system intervenes, such as ESP® or PRE-SAFE® Brake

- ESP® is deactivated
- a loss of tyre pressure or a defective tyre is detected

Activating Active Blind Spot Assist



- ▶ Make sure that the radar sensor system (▷ page 237) and Active Blind Spot Assist (▷ page 232) are activated in the on-board computer.
- ▶ Turn the key to position **2** in the ignition lock. Warning lamps ① in the exterior mirrors light up red for approximately 1.5 seconds and then turn yellow.

Active Lane Keeping Assist

Important safety notes

If you fail to adapt your driving style, Active Lane Keeping Assist can neither reduce the risk of accident nor override the laws of physics. Active Lane Keeping Assist cannot take into account road, weather or traffic conditions. Active Lane Keeping Assist is only an aid. You are responsible for the distance to the vehicle in front, for vehicle speed, for braking in good time, and for staying correctly in lane.

Active Lane Keeping Assist cannot continuously keep your vehicle in its lane.

WARNING

Active Lane Keeping Assist cannot always clearly detect lane markings.

In such cases, Active Lane Keeping Assist can:

- give an unnecessary warning and then make a course-correcting brake application to the vehicle
- neither give a warning nor intervene

There is a risk of an accident.

Always pay particular attention to the traffic situation and keep within the lane, especially if Active Lane Keeping Assist alerts you. Terminate the intervention in a non-critical driving situation.

The system may be impaired or may not function if:

- there is poor visibility, e.g. due to insufficient illumination of the road, or due to snow, rain, fog or spray
- there is glare, e.g. from oncoming traffic, the sun, or reflection from other vehicles (e.g. if the road surface is wet)
- the windscreen is dirty, misted up, damaged or covered, for instance by a sticker, in the vicinity of the camera
- no, or several, unclear lane markings are present for one lane, e.g. in a construction area
- the lane markings are worn away, dark or covered up, e.g. by dirt or snow
- the distance to the vehicle in front is too small and the lane markings thus cannot be detected
- the lane markings change quickly, e.g. lanes branch off, cross one another or merge
- the road is narrow and winding
- there are highly variable shade conditions on the roadway

General notes

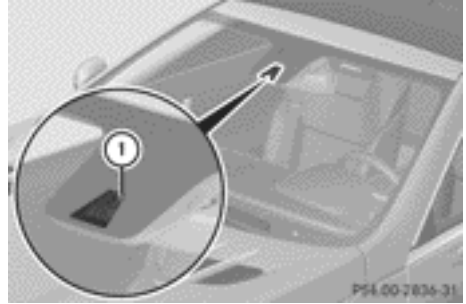

Active Lane Keeping Assist monitors the area in front of your vehicle by means of a camera ① at the top of the windscreen. Active Lane Keeping Assist detects lane markings on the road and warns you before you leave your lane unintentionally. If you do not react to the warning, a lane-correcting application of the brakes can bring the vehicle back into the original lane.

If you select **km** on the on-board computer in the **Display unit Speed-/odometer** function (▷ page 233), Active Lane Keeping Assist is activated starting at a speed of 60 km/h. If the **miles** display unit is selected, the assistance range begins at 40 mph.

Warning vibration in the steering wheel

A warning may be given if a front wheel passes over a lane marking. It will warn you by means of intermittent vibration in the steering wheel for up to 1.5 seconds.

In order that you are warned only when necessary and in good time if you cross the lane marking, the system recognises certain conditions and warns you accordingly.

The warning vibration occurs earlier if:

- you approach the outer lane marking on a bend.
- the road has very wide lanes, e.g. a motorway.
- the system recognises solid lane markings.

The warning vibration occurs later if:

- the road has narrow lanes.
- you cut the corner on a bend.

Lane-correcting brake application

WARNING

A lane-correcting brake application cannot always bring the vehicle back into the original lane. There is a risk of an accident.

Always steer, brake or accelerate yourself, especially if Active Lane Keeping Assist warns you or makes a lane-correcting brake application.

WARNING

Active Lane Keeping Assist does not detect traffic conditions or road users. In very rare cases, the system may make an inappropriate brake application, e.g. after intentionally driving over a solid lane marking. There is a risk of an accident.

An inappropriate brake application may be interrupted at any time if you steer slightly in the opposite direction. Always make sure that there is sufficient distance to the side for other traffic or obstacles.

In rare cases, Active Lane Keeping Assist can recognise unclear markings or particular structures on the roadway as solid lane markings. An inappropriate brake application may be interrupted at any time if you steer slightly in the opposite direction.



If a lane-correcting brake application occurs, display  appears in the multifunction display.

If you leave your lane under certain circumstances, the vehicle will brake briefly on one side. This is designed to help you bring the vehicle back into the original lane.

This function is available in the range between 60 km/h and 200 km/h.

A lane-correcting brake application can only be made after driving over a solid, recognisable lane marking. Before this, a warning must be emitted by means of intermittent vibration in the steering wheel. In addition, a lane with lane markings on both sides must be recognised. The brake application also slightly reduces driving speed.

 A further lane-correcting brake application can only occur after your vehicle has returned to the original lane.

No lane-correcting brake application occurs if:

- you clearly and actively steer, brake, or accelerate.
- you cut the corner on a sharp bend.
- you have switched on the turn signals.
- a driving safety system intervenes, such as ESP[®], PRE-SAFE[®] Brake or Active Blind Spot Assist.
- you have adopted a sporty driving style with high cornering speeds or high rates of acceleration.
- ESP[®] is deactivated.
- the transmission is not in position **D**.
- a loss of tyre pressure or a defective tyre has been detected and displayed.

Active Lane Keeping Assist does not detect road and traffic conditions. An inappropriate brake application may be interrupted at any time if:

- you steer slightly in the opposite direction.
- you switch on the turn signal.
- you clearly brake or accelerate.

A lane-correcting brake application is interrupted automatically if:

- a driving safety system intervenes, such as ESP®, PRE-SAFE® Brake or Active Blind Spot Assist.
- lane markings can no longer be recognised.

Activating Active Lane Keeping Assist

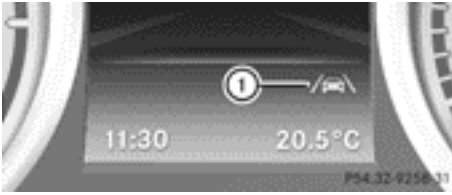

- ▶ Switch on Active Lane Keeping Assist using the on-board computer; to do so, select **Standard** or **Adaptive** (▷ page 232). Symbol ① appears in the multifunction display.

If **Standard** is selected, no warning vibration occurs if:

- you have switched on the turn signals. In this case, the warnings are suppressed for a certain period of time.
- a driving safety system intervenes, such as ABS, BAS or ESP®.

If **Adaptive** is selected, no warning vibration occurs if:

- you have switched on the turn signals. In this case, the warnings are suppressed for a certain period of time.
- a driving safety system intervenes, such as ABS, BAS or ESP®.
- you accelerate hard, e.g. kickdown.
- you brake hard.
- you steer actively, e.g. swerve to avoid an obstacle or change lane quickly.
- you cut the corner on a sharp bend.

Useful information	222
Important safety notes	222
Displays and operation	222
Menus and submenus	225
Display messages	241
Warning and indicator lamps	269

Useful information

- i** This Owner's Manual describes all models, series and optional equipment for your vehicle that were available at the time of going to press. National variations are possible. Note that your vehicle may not be equipped with all of the functions described. This is also the case for systems and functions relevant to safety.
- i** Read the information on qualified specialist workshops: (▷ page 38).

Important safety notes

WARNING

Operating the integrated information systems and communications equipment in the vehicle while driving will distract you from traffic conditions. You could then lose control of the vehicle. There is a risk of an accident.

Only operate these devices if road traffic conditions permit. If you are unsure about the surrounding conditions, pull over to a safe location and make entries only while the vehicle is stationary.

WARNING

If the instrument cluster has failed or malfunctioned, you may not recognise function restrictions relevant to safety. The operating safety of your vehicle may be impaired. There is a risk of an accident.

Drive on carefully. Have the vehicle checked at a qualified specialist workshop immediately.

You must observe the legal requirements for the country in which you are currently driving when operating the on-board computer.

The on-board computer only shows messages or warnings from certain systems in the multifunction display. You should therefore make sure your vehicle is operating safely at all

times. Otherwise, a vehicle that is not operating safely may cause an accident.

For an illustration of the instrument cluster; see (▷ page 44).



Displays and operation

Instrument cluster lighting

The lighting in the instrument cluster, in the displays and the controls in the vehicle interior can be adjusted using the brightness control knob.

The brightness control knob is on the bottom left of the instrument cluster (▷ page 44).

- ▶ Turn the brightness control knob anti-clockwise or clockwise.

If the light switch is set to  **AUTO**,  **200%** or , the brightness is dependant upon the brightness of the ambient light.

- i** The light sensor in the instrument cluster automatically controls the brightness of the multifunction display.

In daylight, the displays in the instrument cluster are not lit.

Coolant temperature gauge

The coolant temperature gauge is in the instrument cluster on the right-hand side (▷ page 44).

The reading may rise up to 120 °C under normal driving conditions if the coolant has been filled correctly.

At high outside temperatures and when driving uphill, the coolant temperature may rise to the end of the scale.

Rev counter

- !** Do not drive in the overrevving range. Doing so will damage the engine.

The red band in the rev counter indicates the engine's overrevving range.

The fuel supply is interrupted to protect the engine when the red band is reached.

Outside temperature display

You should pay special attention to road conditions when temperatures are around the freezing point.

The outside temperature display is in the multifunction display (▷ page 224).

Changes in the outside temperature are displayed after a short delay.

Speedometer with segments

The segments in the speedometer indicate which speed range is available.

- Cruise control activated (▷ page 178):
The segments light up from the stored speed to the maximum speed.
- Variable SPEEDTRONIC activated (▷ page 190):
The segments light up from the start of the scale to the selected limit speed.
- DISTRONIC PLUS activated (▷ page 181):
One or two segments in the set speed range light up.
- DISTRONIC PLUS detects a vehicle in front:
The segments between the speed of the vehicle in front and the stored speed light up.

Operating the on-board computer

Overview









- ① Multifunction display
- ② Switches on LINGUATRONIC; see the separate operating instructions
- ③ Right control panel
- ④ Left control panel
- ⑤ Back button



► **To activate the on-board computer:** turn the key to position **1** in the ignition lock.



You can control the multifunction display and the settings in the on-board computer using the buttons on the multifunction steering wheel.

Left control panel



	• Calls up the menu and menu bar
	
	Press briefly:
	<ul style="list-style-type: none"> • Scrolls through lists • Selects a submenu or function • In the Audio menu: selects a stored station, an audio track or a video scene • In the Tel (telephone) menu: switches to the phone book and selects a name or telephone number
	Press and hold:
	<ul style="list-style-type: none"> • In the Audio menu: selects the previous/next station or selects an audio track or a video scene using rapid scrolling • In the Tel (Telephone) menu: starts rapid scrolling if the phone book is open
	<ul style="list-style-type: none"> • Confirms selection/display message • In the Tel (telephone) menu: switches to the telephone book and starts dialling the selected number • In the Audio menu: stops the station search function at the desired station

Right control panel

	<ul style="list-style-type: none"> • Rejects or ends a call • Exits telephone book/redial memory
	<ul style="list-style-type: none"> • Makes or accepts a call • Switches to the redial memory

	• Adjusts the volume
	
	• Mute

Back button



	Press briefly:
	<ul style="list-style-type: none"> • Back • Switches off LINGUATRONIC; see the separate operating instructions • Hides display messages/calls up the last Trip menu function used • Exits the telephone book/redial memory
	Press and hold:
	<ul style="list-style-type: none"> • Calls up the standard display in the Trip menu

Multifunction display



- ① Transmission position (▷ page 163)
- ② Drive program (▷ page 163)
- ③ Description field
- ④ Menu bar











- ⑤ Outside temperature or speed
(▷ page 233)
- ⑥ Time (▷ page 304)

► **To show the menu bar** ④: press the  or  button on the steering wheel.

Menu bar ④ disappears after a few seconds.



Text field ③ shows the selected menu or submenu as well as display messages.

The following messages can appear in the multifunction display:

-  Upshift indicator (▷ page 168)
-  Active Parking Assist
(▷ page 204)
-  Cruise control (▷ page 178)
-  SPEEDTRONIC (▷ page 190)
-  Adaptive Main-beam Assist
(▷ page 133)
-  ATTENTION ASSIST
(▷ page 211)
-  ECO start/stop function
(▷ page 156)
-  Speed Limit Assist
(▷ page 212)
-  Active Lane Keeping Assist
(▷ page 216)
-  HOLD function (▷ page 193)
-  PRE-SAFE® Brake (▷ page 78)
- 120 km/h!** Maximum permissible speed exceeded (only for certain countries)

Menus and submenus

Menu overview

Press the  or  button on the steering wheel to call up the menu bar and select a menu.

Operating the on-board computer
(▷ page 223).

Depending on the equipment fitted in the vehicle, you can call up the following menus:

- **Trip** menu (▷ page 225)
- **Navi** menu (navigation instructions)
(▷ page 226)
- **Audio** menu (▷ page 228)
- **Tel** menu (telephone) (▷ page 229)
- **Assist.** menu (assistance) (▷ page 231)
- **Serv.** menu (▷ page 232)
- **Settings** menu (▷ page 233)
- **AMG** menu in AMG vehicles (▷ page 238)

Trip menu

Standard display



- Press and hold the  button on the steering wheel until the **Trip** menu with total distance recorder ① and trip meter ② is shown.

Trip computer "From start" or "From reset"



Example: "From start" trip computer

- ① Distance
- ② Time
- ③ Average speed
- ④ Average fuel consumption

- ▶ Press the or button on the steering wheel to select the **Trip** menu.
- ▶ Press or to select **From start** or **From reset**.

The values in the **From start** submenu are calculated from the start of a journey whilst the values in the **From reset** submenu are calculated from the last time the submenu was reset (▷ page 226).

The **From start** trip computer is automatically reset when:

- The ignition has been switched off for more than four hours.
- 999 hours have been exceeded.
- 9,999 kilometres have been exceeded.

The **From reset** trip computer is automatically reset if the value exceeds 9,999 hours or 99,999 kilometres.

Displaying the range and current fuel consumption

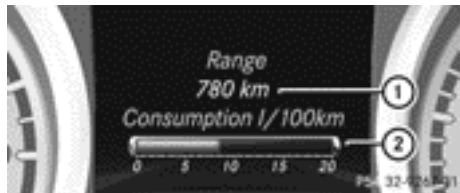

- ① Approximate range
 - ② Current fuel consumption (not for AMG vehicles)
- ▶ Press the or button on the steering wheel to select the **Trip** menu.
 - ▶ Press the or button to select the current fuel consumption (not for AMG vehicles) and the approximate range.

The approximate range which can be covered depends on the fuel level and your current driving style. If there is only a small amount of fuel left in the fuel tank, the display shows a vehicle being refuelled instead of the range.

Digital speedometer



- ① Digital speedometer

- ▶ Press the or button on the steering wheel to select the **Trip** menu.
- ▶ Press the or button to select the digital speedometer.

Resetting values

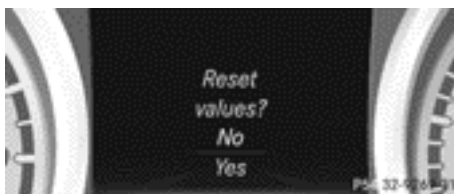

Example: resetting the trip computer "From start"

- ▶ Press the or button on the steering wheel to select the **Trip** menu.
- ▶ Press the or button to select the function that you wish to reset.
- ▶ Press .
- ▶ Press the button to select **Yes** and press the to confirm.

You can reset the values of the following functions:

- trip meter
- trip computer "From start"
- trip computer "From reset"

Navigation menu

Displaying navigation instructions

In the **Navi** menu, the multifunction display shows navigation instructions. For further information, see (▷ page 314).

- ▶ Switch on COMAND Online (▷ page 293).
- ▶ Press the ◀ or ▶ button on the steering wheel to select the **Navi** menu.

Route guidance not active

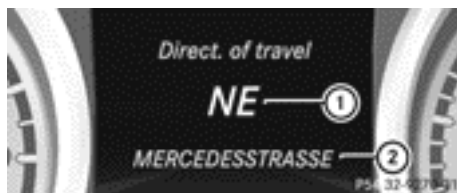

- ① Direction of travel
- ② Current street

Activated route guidance

No change of direction announced



- ① Distance to the destination
- ② Distance to the next change of direction
- ③ Current street
- ④ Symbol "follow the road's course"

Change of direction announced without a lane recommendation



- ① Road to which the change of direction leads
- ② Distance to change of direction and visual distance display
- ③ Change-of-direction icon

When a change of direction has been announced, you will see visual distance display ② next to the symbol for change of direction ③. This shortens from the bottom to the top of the display as you approach the point of the announced change of direction.

Change of direction announced with a lane recommendation

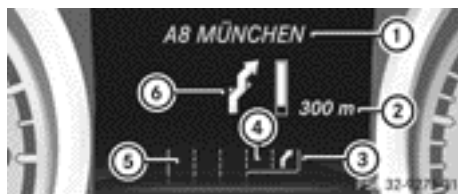

- ① Road to which the change of direction leads
- ② Distance to change of direction and visual distance display
- ③ Lane recommendation
- ④ New lane during a change of direction
- ⑤ Lane continues through change of direction
- ⑥ Change-of-direction icon

On multi-lane roads, lane recommendation ③ may be shown for the next change of direction. During the change of direction, additional lanes may be displayed.

Lane recommendations are only displayed if the relevant data is available on the digital map.

Other status indicators of the navigation system

- : you have reached the destination or an intermediate destination.
- **New route...** or **Calculating route:** a new route is being calculated.
- **Off map** or **Off road:** the vehicle position is outside the area of the digital map (off-map position).
- **No route:** no route could be calculated to the selected destination.

Audio menu

Selecting a radio station



- ① Waveband
- ② Station frequency with memory position

- i** Station ② is displayed with the station frequency or station name. The memory position is only displayed along with station ② if this has been stored.
- ▶ Switch on COMAND Online (▷ page 293).
- ▶ Select Radio (▷ page 453).
- ▶ Press the ◀ or ▶ button on the steering wheel to select the **Audio** menu.
- ▶ **To select a stored station:** briefly press the ▲ or ▼ button.
- ▶ **To select a station from the station list:** press and briefly hold the ▲ or ▼ button.

If no station list is received:

- ▶ **To select a station using the station search:** press and briefly hold the ▲ or ▼ button.
- i** Switching wavebands (▷ page 455).
Storing stations (▷ page 457).
- i** DAB radio operation (**D**igital **A**udio **B**roadcasting) (▷ page 453).

Audio player or audio media operation



Display CD/DVD changer (example)

- ① Current CD in the CD/DVD changer
- ② Current track

Audio data from various audio devices or media can be played, depending on the equipment fitted in the vehicle.

- ▶ Switch on COMAND Online (▷ page 293).
- ▶ Select audio player or audio media (▷ page 463).
- ▶ Press the ◀ or ▶ button on the steering wheel to select the **Audio** menu.
- ▶ **To select the next/previous track:** briefly press the ▲ or ▼ button.
- ▶ **To select a track from the track list (rapid scrolling):** press and hold the ▲ or ▼ button until desired track ② has been reached.

If you press and hold the ▲ or ▼ button, the rapid scrolling speed is increased. Not all audio devices or media support this function.

If track information is stored on the audio device or medium, the multifunction display will show the number and title of the track. The current track does not appear in audio AUX mode (**A**uxiliary audio mode: external audio source connected).

Video DVD operation



Display CD/DVD changer (example)

- ① Current DVD in the CD/DVD changer
- ② Current scene

- ▶ Switch on COMAND Online (▷ page 293).
- ▶ Select DVD-V (▷ page 501).
- ▶ Press the ◀ or ▶ button on the steering wheel to select the **Audio** menu.
- ▶ **To select the next or previous scene:** briefly press the ▲ or ▼ button.
- ▶ **To select a scene from the scene list (rapid scrolling):** press and hold the ▲ or ▼ button until desired scene ② has been reached.

TV operation



- ① Function
- ② Station frequency with memory position

- ❗ The memory position is only displayed along with station ② if this has been stored.
- ▶ Switch on COMAND Online (▷ page 293).
- ▶ Select TV (▷ page 494).
- ▶ Press the ◀ or ▶ button on the steering wheel to select the **Audio** menu.

- ▶ **To select a stored station:** briefly press the ▲ or ▼ button.

- ▶ **To select a station from the station list:** press and briefly hold the ▲ or ▼ button.

- ❗ Storing a TV channel (▷ page 497).
- ❗ Depending on the digital TV broadcaster, radio stations can also be received. The multifunction display shows **TV (RADIO)**.

Telephone menu

Introduction

⚠ WARNING

Observe the legal requirements of the country in which you are currently driving regarding the use of mobile phones in the vehicle.

If it is permitted to use mobile phones while the vehicle is in motion, you should only use them when the road and traffic conditions allow. Otherwise, you may be distracted from the traffic conditions, cause an accident and injure yourself and others.

- ▶ Switch on the mobile phone (see the separate operating instructions).
- ▶ Switch on COMAND Online (▷ page 293).
- ▶ Insert the mobile phone into the bracket (▷ page 519).

or

- ▶ Establish a Bluetooth® connection to COMAND Online (▷ page 381).
- ▶ Press the ◀ or ▶ button on the steering wheel to select the **Te1** menu.

You will see one of the following display messages in the multifunction display:

- **Please enter PIN:** the mobile phone has been placed in the mobile phone bracket and the PIN has not been entered. When you enter your PIN via the mobile phone, LINGUATRONIC or COMAND

Online, the mobile phone searches for a network.

- **Telephone ready** or the name of the network provider: the mobile phone has found a network and is ready to receive.
- **Telephone No service**: there is no network available or the mobile phone is searching for a network.

i You can obtain further information about suitable mobile phones and connecting mobile phones via Bluetooth®:

- in any Mercedes-Benz Service Centre
- on the Internet at <http://www.mercedes-benz.com/connect>

Accepting a call

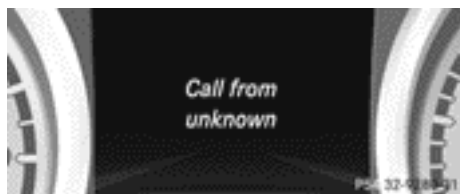

Example: incoming call

- ▶ Press the  button on the steering wheel to accept an incoming call.

If someone calls you when you are in the **Te1** menu, a display message appears in the multifunction display.





You can accept a call even if you are not in the **Te1** menu.

Rejecting or ending a call

- ▶ Press the  button on the steering wheel.

You can end or reject a call even if you are not in the **Te1** menu.

Dialling a number from the phone book

- ▶ Press the  or  button on the steering wheel to select the **Te1** menu.
- ▶ Press the ,  or **OK** button to call up the phone book.

- ▶ Press the  or  button to select the desired name.

or

- ▶ **To begin rapid scrolling:** press and hold the  or  button for longer than one second.

Rapid scrolling stops when you release the button or reach the end of the list.

- ▶ **If only one telephone number is stored for a name:** press the  or **OK** button to start dialling.

or

- ▶ **If there is more than one number for a particular name:** press the  or **OK** button to display the numbers.

- ▶ Press the  or  button to select the number you want to dial.

- ▶ Press the  or **OK** button to start dialling.

or

- ▶ **To exit the telephone book:** press the  or  button.

Redialling

The on-board computer saves the last names or numbers dialled in the redial memory.

- ▶ Press the  or  button on the steering wheel to select the **Te1** menu.

- ▶ Press the  button to switch to the redial memory.

- ▶ Press the  or  button to select the desired name or number.

- ▶ Press the  or **OK** button to start dialling.

or

- ▶ **To exit the redial memory:** press the  or  button.

Assistance menu

Introduction



In the **Assist.** menu, you have the following options:

- AMG vehicles only: set the vehicle level (▷ page 198)
- show Speed Limit Assist and activate/deactivate its message function (▷ page 231)
- show the distance display (▷ page 231)
- activate/deactivate the PRE-SAFE® Brake (▷ page 231)
- activate/deactivate ATTENTION ASSIST (▷ page 232)
- activate/deactivate Active Blind Spot Assist (▷ page 232)
- activate/deactivate Active Lane Keeping Assist (▷ page 232)

Speed Limit Assist

Displaying Speed Limit Assist

- ▶ Press the or button on the steering wheel to select the **Assist.** menu.
 - ▶ Press the or button to select **Speed Lim. Asst..**
 - ▶ Press .
- Under certain conditions, detected speed limits are shown in the multifunction display (▷ page 212).

Activating/deactivating the Speed Limit Assist message function

- ▶ Press the or button on the steering wheel to select the **Assist.** menu.
- ▶ Press the or button to select **Speed Lim. Asst..**

- ▶ Press the .
- The multifunction display shows Speed Limit Assist.
- ▶ Press the .
- The current selection is displayed.
- ▶ **To activate or deactivate:** press .
- If the Speed Limit Assist message function is activated, a detected speed limit is automatically displayed for five seconds. Other items in the multifunction display are not shown during this time.

If Speed Limit Assist is operational and the message function is activated, the multifunction display shows the symbol when the ignition is switched on.

Showing the distance display

- ▶ Press the or button on the steering wheel to select the **Assist.** menu.
 - ▶ Press the or button to select **Distance display.**
 - ▶ Press .
- The DISTRONIC PLUS distance display appears in the multifunction display (▷ page 188).

Activating/deactivating PRE-SAFE® Brake

PRE-SAFE® Brake is only available in vehicles with DISTRONIC PLUS.





- ▶ Press the or button on the steering wheel to select the **Assist.** menu.
 - ▶ Press the or button to select **PRE-SAFE Brake.**
 - ▶ Press the .
- The current selection is displayed.
- ▶ **To activate/deactivate:** press again.

When PRE-SAFE® Brake is activated, the multifunction display shows the symbol as long as the HOLD function is not activated (▷ page 193).

Vehicles with Active Parking Assist: if PARKTRONIC is activated and you are driving at a speed under 35 km/h, the **P** Active Parking Assist symbol is shown instead of the  symbol (▷ page 204).

For more information on PRE-SAFE® Brake, see (▷ page 78).

Activating/deactivating ATTENTION ASSIST





- ▶ Press the  or  button on the steering wheel to select the **Assist.** menu.
- ▶ Press the  or  button to select **Attention Asst.**
- ▶ Press .

The current selection is displayed.
- ▶ **To activate/deactivate:** press  again.

When ATTENTION ASSIST is activated, the  symbol appears in the multifunction display when the ignition is on.

For further information about ATTENTION ASSIST, see (▷ page 211).





Activating/deactivating Active Blind Spot Assist





- ▶ Press the  or  button on the steering wheel to select the **Assist.** menu.
- ▶ Press the  or  button to select **Blind Spot Asst..**
- ▶ Press .

The current selection is displayed.
- ▶ **To activate/deactivate:** press  again.

For further information about Active Blind Spot Assist, see (▷ page 213).

Activating/deactivating Active Lane Keeping Assist

- ▶ Press the  or  button on the steering wheel to select the **Assist.** menu.
- ▶ Press the  or  button to select **Lane Keep. Asst.**
- ▶ Press .

The current selection is displayed.
- ▶ Press the  button to confirm.
- ▶ Press  or  to set **Off, Standard** or **Adaptive.**
- ▶ Press the  button to save the setting.

When Active Lane Keeping Assist is activated, the  symbol appears in the multifunction display when the ignition is on.

For further information about Active Lane Keeping Assist, see (▷ page 216).

Service menu



In the **Serv.** menu, you have the following options:

- call up display messages (▷ page 241)
- restart the tyre pressure loss warning system (▷ page 567)
- check the tyre pressure electronically (▷ page 568)
- call up service due date (▷ page 535)

Settings menu

Introduction



In the **Settings** menu, you have the following options:

- change the instrument cluster settings (▷ page 233)
- change the light settings (▷ page 234)
- change the vehicle settings (▷ page 236)
- change the convenience settings (▷ page 237)
- restore the factory settings (▷ page 233)

Resetting to factory settings

- ▶ Press the or button on the steering wheel to select the **Settings** menu.
- ▶ Press the or button to select the **Factory setting** submenu.
- ▶ Press the button to confirm. The **Reset all settings?** message appears.
- ▶ Press the or button to select **No** or **Yes**.
- ▶ Press the button to confirm the selection. If you have selected **Yes**, the multifunction display shows a confirmation message.

For safety reasons, not all functions are reset: the **Limit speed (winter tyres)** function in permanent SPEEDTRONIC can only be set in the **Vehicle** submenu. If you want to reset the **Daytime driving lights** in the **Light** submenu, you must turn the key to position 1 in the ignition lock.

Instrument cluster

Selecting the unit of measurement for distance

The **Display unit Speed-/odometer:** function allows you to choose whether certain displays appear in kilometres or miles in the multifunction display.

You can determine whether the multifunction display shows some messages in miles or kilometres.

- ▶ Press the or button on the steering wheel to select the **Settings** menu.
- ▶ Press the or button to select the **Inst. cluster** submenu.
- ▶ Press the button to confirm.
- ▶ Press the or button to select the **Display unit Speed-/odometer:** function. You will see the selected setting: **km** or **miles**.

- ▶ Press the button to save the setting.





The selected unit of measurement for distance applies to:

- the digital speedometer in the **Trip** menu
- total distance recorder and the trip meter
- trip computer
- current consumption and the range
- the navigation instructions in the **Navi** menu
- Cruise control
- SPEEDTRONIC
- DISTRONIC PLUS
- ASSYST PLUS service interval display

Selecting the permanent display function

You can determine whether the multifunction display permanently shows your speed or the outside temperature.

- ▶ Press the or button on the steering wheel to select the **Settings** menu.
- ▶ Press the or button to select the **Inst. cluster** submenu.

- ▶ Press the  button to confirm.
- ▶ Press the  or  button to select the **Permanent display:** function.
You will see the selected setting: **outside temperature** or **Dig. speedo [mph]**.
- ▶ Press the  button to save the setting.









 Speed is displayed in mph.

 Vehicles for the United Kingdom: this function is not available.

Lights







Setting the daytime driving lights

The **Daytime driving lights** function can only be switched on with the engine turned off.

- ▶ Press the  or  button on the steering wheel to select the **Settings**.
- ▶ Press the  or  button to select the **Light** submenu.
- ▶ Press  to confirm.
- ▶ Press the  or  button to select **Daytime driving lights** function.
If the **Daytime driving lights** function has been switched on, the cone of light and the  symbol in the multifunction display are shown in red.
- ▶ Press the  button to save the setting.

Further information on daytime driving lights (> page 127).

Switching the Intelligent Light System on/off

- ▶ Press the  or  button on the steering wheel to select the **Settings** menu.
- ▶ Press the  or  button to select the **Light** submenu.
- ▶ Press the  button to confirm.
- ▶ Press  or  to select the **Intell. Light System** function.
If the **Intell. Light System** function has been switched on, the cone of light and the

 symbol in the multifunction display are shown in red.









- ▶ Press the  button to save the setting.

When you activate **Intell. Light System**, you activate the following functions:

- motorway mode
- active light function
- cornering light function
- extended range foglamps

If you set the dipped-beam headlamps for driving on the right/left (> page 234), the multifunction display shows the **System inoperative** display message under the image of the vehicle for the **Intell. Light System** function in the **Light** submenu.

Setting the dipped-beam headlamps for driving on the left/right

- ▶ Press the  or  button on the steering wheel to select the **Settings** menu.
- ▶ Press the  or  button to select the **Light** submenu.
- ▶ Press  to confirm.
- ▶ Press  or  to select the **Dipped beams Setting for:** function.
You will see the selected setting: **Right-side traffic** or **Left-side traffic**.
- ▶ Press the  button to save the setting.
If you change the setting, conversion does not take place until the next time the vehicle is stationary.

You can use this function to switch between symmetrical and asymmetrical dipped beam (> page 126).

If you set the dipped-beam headlamps for driving on the right/left, then motorway mode and the extended range foglamps are unavailable.

A qualified specialist workshop can set the dipped-beam headlamps for driving on the right or left.

Switching Adaptive Highbeam Assist on/off

- ▶ Press the or button on the steering wheel to select the **Settings** menu.
- ▶ Press the or button to select the **Light** submenu.
- ▶ Press the button to confirm.
- ▶ Press the or button to select the **Adapt. main-beam** function.

If the **Adapt. main beam** function has been switched on, the cone of light and the symbol in the upper multifunction display are shown in red.

- ▶ Press the button to save the setting.

When Adaptive Highbeam Assist is activated, the symbol appears in the lower multifunction display.

For further information about Adaptive Highbeam Assist, see (▷ page 132).

Setting the brightness of the ambient lighting

- ▶ Press the or button on the steering wheel to select the **Settings** menu.
- ▶ Press the or button to select the **Light** submenu.
- ▶ Press the button to confirm.
- ▶ Press the or button to select the **Amb. light +/-** function.
You will see the selected setting.
- ▶ Press the button to confirm.
- ▶ Press the or button to adjust the brightness to any level from **Off** to **Level 5** (bright).
- ▶ Press the or button to save the setting.

Setting the ambient lighting colour

- ▶ Press the or button on the steering wheel to select the **Settings** menu.
- ▶ Press the or button to select the **Light** submenu.
- ▶ Press the button to confirm.

- ▶ Press the or button to select the **Ambient light colour** function.
- ▶ Press the button to confirm.
- ▶ Press the or button to set the colour to **SOLAR**, **SOLAR orange** or **SOLAR red**.
- ▶ Press the or button to save the setting.

Activating/deactivating the surround lighting and exterior lighting delayed switch-off

- ▶ Press the or button on the steering wheel to select the **Settings** menu.
- ▶ Press the or button to select the **Light** submenu.
- ▶ Press to confirm.
- ▶ Press the or button to select the **Surround lighting** function.
When the **Surround lighting** function is activated, the light cone and the area around the vehicle are displayed in red in the multifunction display.
- ▶ Press the button to save the setting.

Deactivating delayed switch-off of the exterior lighting temporarily:

- ▶ Before leaving the vehicle, turn the key to position **0** in the ignition lock.
- ▶ Turn the key to position **2** in the ignition lock.
The exterior lighting delayed switch-off is deactivated.

Delayed switch-off of the exterior lighting is reactivated the next time you start the engine.

If you have activated the **Surround lighting** function and the light switch is set to **AUTO**, the following functions are activated when it is dark:

- **surround lighting:** the exterior lighting remains lit for 40 seconds after unlocking with the key. If you start the engine, the surround lighting is switched off and auto-

matic headlamp mode is activated (▷ page 127).









- **exterior lighting delayed switch-off:** the exterior lighting remains lit for 60 seconds after the engine is switched off. If you close all the doors and the boot lid, the exterior lighting goes off after 15 seconds.

i Depending on your vehicle's equipment, when the surround lighting and delayed switch-off exterior lighting are on, the following light up:

- side lamps
- dipped-beam headlamps
- daytime driving lights
- surround lighting in the exterior mirrors





Activating/deactivating the interior lighting delayed switch-off







If you activate the **Lighting delayed sw.-off** function, the interior lighting remains on for 20 seconds after you remove the key from the ignition lock.

- ▶ Press the  or  button on the steering wheel to select the **Settings** menu.
- ▶ Press the  or  button to select the **Light** submenu.
- ▶ Press the  button to confirm.
- ▶ Press  or  to select the **Lighting delayed sw.-off** function. When the **Lighting delayed sw.-off** function is activated, the vehicle interior is displayed in red in the multifunction display.
- ▶ Press the  button to save the setting.

Vehicle









Setting permanent SPEEDTRONIC

- ▶ Press the  or  button on the steering wheel to select the **Settings** menu.
- ▶ Press the  or  button to select the **Vehicle** submenu.
- ▶ Press the  button to confirm.

- ▶ Press the  or  button to select the **Limit speed (winter tyres):** function. You will see the current setting.
- ▶ Press the  button to confirm.
- ▶ Press the  or  button to adjust permanent SPEEDTRONIC in increments of ten (**230 km/h to 160 km/h**). The **Off** setting switches permanent SPEEDTRONIC off.
- ▶ Press the  button to store the entry.

For further information on permanent SPEEDTRONIC (▷ page 193).

Switching the automatic locking feature on/off





- ▶ Press the  or  button on the steering wheel to select the **Settings** menu.
- ▶ Press the  or  button to select the **Vehicle** submenu.
- ▶ Press the  button to confirm.
- ▶ Press  or  to select the **Automatic door locks** function. When the **Automatic door locks** function is activated, the vehicle doors are displayed in red in the multifunction display.
- ▶ Press the  button to save the setting.





If you activate the **Automatic door locks** function, the vehicle is centrally locked above a speed of around 15 km/h.

For further information on the automatic locking feature, see (▷ page 92).









Activating/deactivating the acoustic locking confirmation

If you switch on the **Acoustic Lock** function, an acoustic signal sounds when you lock the vehicle.

- ▶ Press the  or  button on the steering wheel to select the **Settings** menu.
- ▶ Press the  or  button to select the **Vehicle** submenu.
- ▶ Press the  button to confirm.

- ▶ Press the  or  button to select the **Acoustic Lock** function.
- If the **Acoustic Lock** function is activated, the  symbol in the multifunction display lights up red.
- ▶ Press the  button to save the setting.

Activating/deactivating the radar sensor system

- ▶ Press the  or  button on the steering wheel to select the **Settings** menu.
- ▶ Press the  or  button to select the **Vehicle** submenu.
- ▶ Press  to confirm.
- ▶ Press the  or  button to select **Radar sensor (See Owner's Man.)**. You will see the selected setting on or off.
- ▶ Press the  button to save the setting.

i In some countries you must deactivate the radar sensor system. For further information; see (▷ page 595).

The following systems are switched off when the radar sensor system is deactivated:

- DISTRONIC PLUS (▷ page 181)
- BAS PLUS (▷ page 73)
- PRE-SAFE® Brake (▷ page 78)
- Active Blind Spot Assist (▷ page 213)

Convenience









Activating/deactivating the EASY-ENTRY/EXIT feature

WARNING

The steering wheel moves when the EASY-ENTRY/EXIT feature is active. There is a risk of occupants becoming trapped. Before activating the EASY-ENTRY/EXIT feature, make sure that nobody can become trapped.









Do not leave children unsupervised in the vehicle, even if they are secured in a child restraint system. The children could open the driver's door and thereby unintentionally acti-

vate the EASY-ENTRY/EXIT feature and become trapped.

- ▶ Press the  or  button on the steering wheel to select the **Settings** menu.
- ▶ Press the  or  button to select the **Convenience** submenu.
- ▶ Press the  button to confirm.
- ▶ Press  or  to select the **Easy Entry/Exit** function.
- If the **Easy Entry/Exit** function is activated, the vehicle steering wheel is displayed in red in the multifunction display.
- ▶ Press the  button to save the setting.

Further information on the EASY-ENTRY/EXIT feature (▷ page 118).





Switching the belt adjustment on/off



- ▶ Press the  or  button on the steering wheel to select the **Settings** menu.
- ▶ Press the  or  button to select the **Convenience** submenu.
- ▶ Press the  button to confirm.
- ▶ Press the  or  button to select the **Belt adjustment** function.
- When the **Belt adjustment** function is activated, the vehicle seat belt is displayed in red in the multifunction display.
- ▶ Press the  button to save the setting.

For further information on belt adjustment, see (▷ page 63).

Switching the fold in mirrors when locking function on/off

When you activate the **Auto. fold in mirrors** function, the exterior mirrors are folded in when the vehicle is locked. When you unlock the vehicle and then open a door, the exterior mirrors fold out again.

- ▶ Press the  or  button on the steering wheel to select the **Settings** menu.
- ▶ Press the  or  button to select the **Convenience** submenu.
- ▶ Press the  button to confirm.

- ▶ Press  or  to select the **Auto. fold-in mirrors** function.
If the **Auto. fold-in mirrors** function is activated, the vehicle's exterior mirror is displayed in red in the multifunction display.
- ▶ Press the  button to save the setting.



- ① To fold the exterior mirrors in or out

If you have switched on the function and you fold the exterior mirrors in using button ① on the door, they will not fold out automatically (▷ page 120).

You can then only fold out the exterior mirrors using button ①.

AMG menu in AMG vehicles

AMG displays

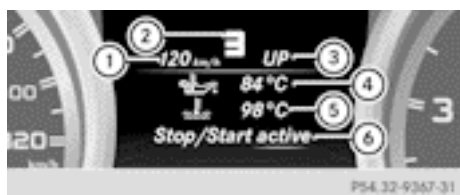

- ① Digital speedometer
- ② Gear indicator
- ③ Upshift indicator
- ④ Engine oil temperature
- ⑤ Coolant temperature
- ⑥ ECO start/stop function status indicator (▷ page 157)

- ▶ Press  or  on the steering wheel to select the **AMG** menu.

Upshift indicator **UP** ③ indicates that the engine has reached the overrevving range when in the manual gearshift program.

Upshift indicator **UP** ③ fades out other messages until you have shifted up.

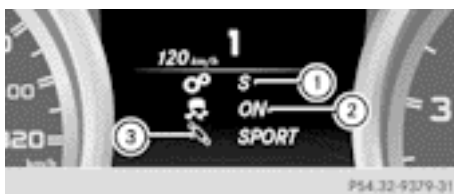

When the engine oil temperature is below 80 °C, the oil temperature is shown in blue. Avoid using the full output of the engine during this time.

SETUP



- ① Drive program (**C/S/S+/M**)
- ② ESP® mode (**ON/OFF**) or SPORT handling mode (**SPORT**)
- ③ Suspension tuning (**SPORT/COMFORT**)

SETUP shows the drive program, the ESP® (Electronic Stability Program) mode and the SPORT handling mode.

- ▶ Press the  or  button on the steering wheel to select the **AMG** menu.
- ▶ Press the  button repeatedly until SETUP is displayed.

or

- ▶ Briefly press the AMG button on the centre console (▷ page 166).

RACETIMER

Displaying and starting the RACETIMER

The RACETIMER is only intended for use on a closed race circuit. Do not use the function on public roads.



- ① Lap
- ② RACETIMER

You can start the RACETIMER when the engine is running or if the key is in position 2 in the ignition lock.

- ▶ Press or on the steering wheel to select the **AMG** menu.
- ▶ Press the button repeatedly until the RACETIMER is shown.
- ▶ **To start:** press the button to start the RACETIMER.

Displaying the intermediate time

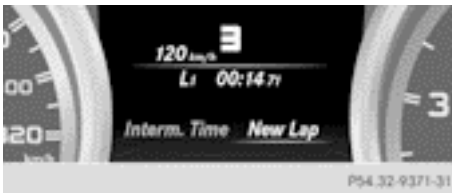

- ▶ Press the or button to select **Interm. Time**.
- ▶ Press to confirm.
The intermediate time is displayed for five seconds.

Starting a new lap

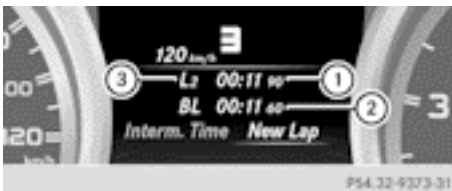

- ① RACETIMER
- ② Fastest lap time (best lap)
- ③ Lap

- ▶ Press to confirm **New Lap**.

i It is possible to store a maximum of sixteen laps. The 16th lap can only be completed with **Finish Lap**.

Stopping the RACETIMER



- ▶ Press the button on the steering wheel.
- ▶ Press to confirm **Yes**.

The RACETIMER interrupts timing if you stop the vehicle and turn the key to position 1 in the ignition lock. If you turn the key to position 2 or 3 and then press to confirm **Start**, timing is continued.

Resetting the current lap

- ▶ Stop the RACETIMER.
- ▶ Press the or button to select **Reset Lap**.
- ▶ Press to reset the lap time to "0".

Deleting all laps



If you switch off the engine, the RACETIMER is reset to "0" after 30 seconds. All laps are deleted.

You cannot delete individual stored laps. If you have stopped 16 laps, the current lap does not have to be reset.

- ▶ Reset the current lap.
- ▶ Press to confirm **Reset**.
Reset Race Timer? appears in the multi-function display.
- ▶ Press the button to select **Yes** and press the button to confirm.
All laps are deleted.

Overall evaluation

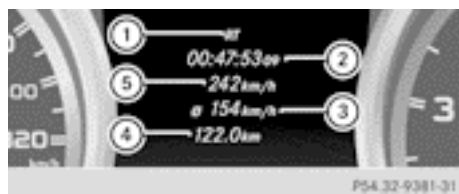

- ① RACETIMER overall evaluation
- ② Total time driven
- ③ Average speed
- ④ Distance covered
- ⑤ Maximum speed

This function is shown if you have stored at least one lap and stopped the RACETIMER.

- ▶ Press the or button on the steering wheel to select the **AMG** menu.
- ▶ Press the button repeatedly until the overall evaluation is shown.

Lap evaluation

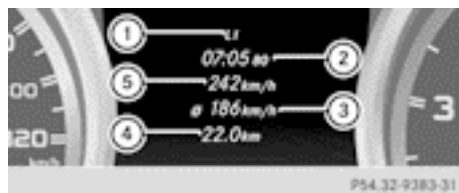

- ① Lap
- ② Lap time
- ③ Average lap speed
- ④ Lap length
- ⑤ Top speed during lap

This function is only available if you have stored at least two laps and have stopped the RACETIMER.

- ▶ Press or on the steering wheel to select the **AMG** menu.
- ▶ Press the button repeatedly until the lap evaluation is shown.
Each lap is shown in a separate submenu.
The fastest lap is indicated by flashing symbol ①.
- ▶ Press the or button to select a different lap evaluation.

Display messages

Introduction

General notes

Display messages appear in the multifunction display.

Display messages with graphic symbols are simplified in the Owner's Manual and may differ from the symbols in the multifunction display.



Please respond in accordance with the display messages and follow the additional notes in this Owner's Manual.

Certain display messages are accompanied by an audible warning tone or a continuous tone.

When you stop and park the vehicle, please observe the notes on:

- HOLD function (> page 193)
- Parking (> page 172)

Hiding display messages







- ▶ Press the  or  button on the steering wheel to hide the display message. The display message is cleared.

The multifunction display shows high-priority display messages in red. Some high-priority display messages cannot be hidden.

The multifunction display shows these messages continuously until the causes for the messages have been remedied.

Message memory

The on-board computer saves certain display messages in the **message memory**. You can call up the display messages:

- ▶ Press the  or  button on the steering wheel to select the **Serv.** menu. If there are display messages, the multifunction display shows **2 messages**, for example.
- ▶ Press the  or  button to select the entry, e.g. **2 messages**.
- ▶ Press  to confirm.
- ▶ Press the  or  button to scroll through the display messages.

When the ignition is switched off, all display messages are deleted apart from some high-priority display messages. Once the causes of the high-priority display messages have been rectified, the corresponding display messages are also deleted.

Safety systems

Display messages





currently unavailable See Owner's Manual

Possible causes/consequences and ► Solutions

ABS (Anti-lock Braking System), ESP® (Electronic Stability Program), BAS (Brake Assist), PRE-SAFE®, the HOLD function and hill start assist are temporarily unavailable.

The adaptive brake lights, BAS PLUS and PRE-SAFE® Brake may also have failed.

In addition, the ,  and  warning lamps light up in the instrument cluster.

ATTENTION ASSIST is deactivated.

Possible causes:

- self-diagnosis is not yet complete.
- the on-board voltage may be insufficient.

 **WARNING**

The brake system continues to function normally, but without the functions listed above. The wheels could therefore lock if you brake hard, for example.

The steerability and braking characteristics may be severely affected. The braking distance in an emergency braking situation can increase.

If ESP® is not operational, ESP® is unable to stabilise the vehicle. The danger of skidding and having an accident increases.

► Carefully drive on a suitable stretch of road, making slight steering movements at a speed above 20 km/h.

If the display message disappears, the functions mentioned above are available again.

If the display message continues to be displayed:



- Drive on carefully.
- Visit a qualified specialist workshop.



inoperative See Owner's Manual





ABS, ESP®, BAS, PRE-SAFE®, the HOLD function and hill start assist are not available due to a malfunction.









The adaptive brake lights, BAS PLUS and PRE-SAFE® Brake may also have failed.







In addition, the ,  and  warning lamps light up in the instrument cluster.







ATTENTION ASSIST is deactivated.











 **WARNING**



Display messages	Possible causes/consequences and ► Solutions
	<p>The brake system continues to function normally, but without the functions listed above. The wheels could therefore lock if you brake hard, for example.</p> <p>The steerability and braking characteristics may be severely affected. The braking distance in an emergency braking situation can increase.</p> <p>If ESP® is not operational, ESP® is unable to stabilise the vehicle. The danger of skidding and having an accident increases.</p> <ul style="list-style-type: none"> ► Drive on carefully. ► Visit a qualified specialist workshop immediately.
<div style="display: flex; align-items: center;">  <p>currently unavailable See Owner's Manual</p> </div>	<p>ESP®, BAS, PRE-SAFE®, the HOLD function and hill start assist are temporarily unavailable.</p> <p>The adaptive brake lights, BAS PLUS and PRE-SAFE® Brake may also have failed.</p> <p>In addition, the  and  warning lamps light up in the instrument cluster.</p> <p>ATTENTION ASSIST is deactivated.</p> <p>The self-diagnosis function may not be complete, for example.</p> <p> WARNING</p> <p>The brake system continues to function normally, but without the functions listed above.</p> <p>The braking distance in an emergency braking situation can thus increase.</p> <p>If ESP® is not operational, ESP® is unable to stabilise the vehicle. The danger of skidding and having an accident increases.</p> <ul style="list-style-type: none"> ► Carefully drive on a suitable stretch of road, making slight steering movements at a speed above 20 km/h. <p>If the display message disappears, the functions mentioned above are available again.</p> <p>If the display message continues to be displayed:</p> <ul style="list-style-type: none"> ► Drive on carefully. ► Visit a qualified specialist workshop.









Display messages	Possible causes/consequences and ► Solutions
 <p data-bbox="87 228 277 284">inoperative See Owner's Manual</p>	<p data-bbox="341 177 1002 233">ESP®, BAS, PRE-SAFE®, the HOLD function and hill start assist are not available due to a malfunction.</p> <p data-bbox="341 244 994 300">The adaptive brake lights, BAS PLUS and PRE-SAFE® Brake may also have failed.</p> <p data-bbox="341 311 960 367">In addition, the  and  warning lamps light up in the instrument cluster.</p> <p data-bbox="341 378 695 402">ATTENTION ASSIST is deactivated.</p> <p data-bbox="352 419 505 448">▲ WARNING</p> <p data-bbox="341 461 1002 517">The brake system continues to function normally, but without the functions listed above.</p> <p data-bbox="341 528 1002 584">The braking distance in an emergency braking situation can thus increase.</p> <p data-bbox="341 595 1002 651">If ESP® is not operational, ESP® is unable to stabilise the vehicle. The danger of skidding and having an accident increases.</p> <ul data-bbox="341 662 736 726" style="list-style-type: none"> ► Drive on carefully. ► Visit a qualified specialist workshop.
   <p data-bbox="87 850 277 906">inoperative See Owner's Manual</p>	<p data-bbox="341 754 991 842">EBD (electronic brake force distribution), ABS, ESP®, BAS, PRE-SAFE®, the HOLD function and hill start assist are not available due to a malfunction.</p> <p data-bbox="341 853 994 909">The adaptive brake lights, BAS PLUS and PRE-SAFE® Brake may also have failed.</p> <p data-bbox="341 920 986 976">In addition, the ,  and  warning lamps light up in the instrument cluster and a warning tone sounds.</p> <p data-bbox="352 994 505 1023">▲ WARNING</p> <p data-bbox="341 1035 1002 1123">The brake system continues to function normally, but without the functions listed above. The front and rear wheels could therefore lock if you brake hard, for example.</p> <p data-bbox="341 1134 1002 1222">The steerability and braking characteristics may be severely affected. The braking distance in an emergency braking situation can increase.</p> <p data-bbox="341 1233 1002 1289">If ESP® is not operational, ESP® is unable to stabilise the vehicle. The danger of skidding and having an accident increases.</p> <ul data-bbox="341 1300 868 1364" style="list-style-type: none"> ► Drive on carefully. ► Visit a qualified specialist workshop immediately.









Display messages	Possible causes/consequences and ► Solutions
 Release parking brake	<p>The red  indicator lamp flashes and a warning tone sounds. A condition for automatic release of the electric parking brake is not fulfilled (► page 173).</p> <p>You are driving with the electric parking brake applied.</p> <p>► Release the electric parking brake manually.</p> <p>The red  indicator lamp flashes and a warning tone sounds. You are making an emergency stop using the electric parking brake (► page 173).</p>
 Parking brake See Owner's Manual	<p>The yellow  warning lamp lights up. The electric parking brake is malfunctioning.</p> <p>To apply:</p> <ul style="list-style-type: none"> ► Switch the ignition off. ► Press the electric parking brake handle for at least ten seconds. ► Move the transmission selector lever to P. ► Consult a qualified specialist workshop. <p>The yellow  warning lamp and the red  indicator lamp are lit. The electric parking brake is malfunctioning.</p> <p>To release:</p> <ul style="list-style-type: none"> ► Switch off the ignition and turn it back on. ► Release the electric parking brake manually. <p>or</p> <ul style="list-style-type: none"> ► Release the electric parking brake automatically (► page 173). <p>If the electric parking brake can still not be released:</p> <ul style="list-style-type: none"> ► Do not drive on. ► Consult a qualified specialist workshop.











Display messages	Possible causes/consequences and ► Solutions
	<p>The red  indicator lamp flashes and the yellow  warning lamp is lit.</p> <p>The electric parking brake is malfunctioning.</p> <p>To release:</p> <ul style="list-style-type: none"> ► Switch off the ignition and turn it back on. ► Release the electric parking brake manually. <p>To apply:</p> <ul style="list-style-type: none"> ► Switch off the ignition and turn it back on. ► Engage the electric parking brake manually. <p>If the red  indicator lamp continues to flash:</p> <ul style="list-style-type: none"> ► Do not drive on. ► Secure the vehicle against rolling away (▷ page 571). ► Move the transmission selector lever to P. ► Turn the front wheels towards the kerb. ► Consult a qualified specialist workshop.
	<p>The yellow  warning lamp lights up. The red  indicator lamp flashes for about ten seconds after the electric parking brake has been applied or released. It then goes out or remains lit.</p> <p>The electric parking brake is malfunctioning.</p> <ul style="list-style-type: none"> ► Switch off the ignition and turn it back on. ► Secure the vehicle against rolling away (▷ page 571). <p>If it is not possible to apply the electric parking brake:</p> <ul style="list-style-type: none"> ► Move the transmission selector lever to P. ► Visit a qualified specialist workshop. <p>If it is not possible to release the electric parking brake:</p> <ul style="list-style-type: none"> ► Release the electric parking brake automatically (▷ page 173). <p>If the electric parking brake can still not be released:</p> <ul style="list-style-type: none"> ► Consult a qualified specialist workshop.
	<p>The yellow  warning lamp lights up. If you manually apply or release the electric parking brake, the red  indicator lamp flashes.</p> <p>The electric parking brake is malfunctioning. It is not possible to apply the electric parking brake manually.</p> <ul style="list-style-type: none"> ► Shift the transmission to P, as the electric parking brake is not applied automatically. ► Visit a qualified specialist workshop.

Display messages	Possible causes/consequences and ► Solutions
<p> Parking brake inoperative</p>	<p>The yellow  warning lamp lights up. The red  indicator lamp flashes for about ten seconds after the electric parking brake has been applied or released. It then goes out or remains lit.</p> <p>The electric parking brake is malfunctioning, e.g. because of over-voltage or undervoltage.</p> <ul style="list-style-type: none"> ► Remove the cause for the overvoltage or undervoltage, e.g. by charging the battery or restarting the engine. ► Apply or release the electric parking brake. <p>If it remains impossible to apply or release the electric parking brake:</p> <ul style="list-style-type: none"> ► Switch off the ignition and turn it back on. ► Apply or release the electric parking brake. <p>If the electric parking brake can still not be released:</p> <ul style="list-style-type: none"> ► Consult a qualified specialist workshop. <p>The display message is only shown while the vehicle is in motion. The red  indicator lamp flashes and the yellow  warning lamp is lit.</p> <p>It is not possible to apply the electric parking brake manually.</p> <ul style="list-style-type: none"> ► Move the transmission selector lever to P. ► Visit a qualified specialist workshop.
<p> Turn on the ignition to release the parking brake</p>	<p>The red  indicator lamp is lit.</p> <p>You attempted to release the electric parking brake while the ignition was switched off.</p> <ul style="list-style-type: none"> ► Key: turn the key to position 1 in the ignition lock. ► KEYLESS-GO: switch on the ignition.
<p> Check brake fluid level</p>	<p>There is insufficient brake fluid in the brake fluid reservoir. In addition, the red  warning lamp lights up in the instrument cluster and a warning tone sounds.</p> <p> WARNING</p> <p>The braking efficiency may be impaired. There is a risk of an accident.</p> <ul style="list-style-type: none"> ► Pull over and stop the vehicle safely as soon as possible, paying attention to road and traffic conditions. Do not continue driving under any circumstances. ► Secure the vehicle against rolling away (► page 172). ► Consult a qualified specialist workshop. ► Do not top up the brake fluid. This does not correct the error.

Display messages	Possible causes/consequences and ► Solutions
 <p>Check brake pad wear</p>	<p>The brake pads/linings have reached their wear limit.</p> <p>► Visit a qualified specialist workshop.</p>
<p>PRE-SAFE inoperative See Owner's Manual</p>	<p>Important functions of PRE-SAFE® have failed. All other occupant safety systems, e.g. airbags, remain available.</p> <p>► Visit a qualified specialist workshop immediately.</p>
<p>PRE-SAFE Function currently limited See Owner's Manual</p>	<p>PRE-SAFE® Brake is deactivated or temporarily inoperative. Possible causes:</p> <ul style="list-style-type: none"> • the function is impaired due to heavy rain or snow. • the sensors in the radiator trim and in the bumpers are dirty. • the radar sensor system is temporarily inoperative, e.g. due to electromagnetic radiation emitted by nearby TV or radio stations or other sources of electromagnetic radiation. • AMG vehicles: ESP® is deactivated. • the system is outside the operating temperature range. • the on-board voltage is too low. <p>Once the causes listed above no longer apply, the display message goes out.</p> <p>PRE-SAFE® Brake is operational again.</p> <p>► Pull over and stop the vehicle safely as soon as possible, paying attention to road and traffic conditions.</p> <p>► Secure the vehicle against rolling away (▷ page 172).</p> <p>► Clean the sensors in the radiator grille and the bumper (▷ page 539).</p> <p>► Restart the engine.</p> <p>► AMG vehicles: reactivate ESP® (▷ page 76).</p>
<p>PRE-SAFE Function limited See Owner's Manual</p>	<p>PRE-SAFE® Brake is inoperative due to a fault. BAS PLUS or the distance warning signal may also have failed.</p> <p>► Visit a qualified specialist workshop.</p>
 <p>Malfunction Consult workshop</p>	<p>The roll bars are defective.</p> <p>⚠ WARNING</p> <p>The roll bars will then possibly not be extended in the event of an accident.</p> <p>This poses an increased risk of injury.</p> <p>► Visit a qualified specialist workshop immediately.</p>



Display messages	Possible causes/consequences and ► Solutions
 <p>Restraint sys. malfunction Consult workshop</p>	<p>There is a malfunction in the SRS (Supplemental Restraint System). The  warning lamp also lights up in the instrument cluster.</p> <p> WARNING</p> <p>The airbags or belt tensioners may either be triggered unintentionally or, in the event of an accident, may not be triggered. This poses an increased risk of injury.</p> <p>► Visit a qualified specialist workshop.</p> <p>For further information about the Supplemental Restraint System; see (► page 55).</p>
 <p>Front left malfunction Consult workshop or Front right malfunction Consult workshop</p>	<p>SRS has malfunctioned at the front on the left or right. The  warning lamp also lights up in the instrument cluster.</p> <p> WARNING</p> <p>The airbags or belt tensioners may either be triggered unintentionally or, in the event of an accident, may not be triggered. This poses an increased risk of injury.</p> <p>► Visit a qualified specialist workshop.</p>
 <p>Left windowbag malfunction Consult workshop or Right windowbag malfunction Consult workshop</p>	<p>There is a malfunction in the left-hand and/or right-hand headbag. The  warning lamp also lights up in the instrument cluster.</p> <p> WARNING</p> <p>The left or right headbag may either be triggered unintentionally or, in the event of an accident, may not be triggered. This poses an increased risk of injury.</p> <p>► Visit a qualified specialist workshop.</p>

Lights	
Display messages	Possible causes/consequences and ► Solutions
 Left cornering light or Right cornering light	The left or right-hand cornering light is faulty. ► Visit a qualified specialist workshop.
 Left dipped beam or Right dipped beam	The left or right-hand dipped-beam headlamp is faulty. ► Visit a qualified specialist workshop.
 Rear left indicator or Rear right indicator	The rear left-hand or rear right-hand turn signal is faulty. ► Visit a qualified specialist workshop.
 Front left indicator or Front right indicator	The front left-hand or front right-hand turn signal is faulty. ► Visit a qualified specialist workshop.
 Left mirror indicator or Right mirror indicator	The turn signal in the left-hand or right-hand exterior mirror is faulty. ► Visit a qualified specialist workshop.
 Third brake lamp	The third brake lamp is faulty. ► Visit a qualified specialist workshop.
 Left brake lamp or Right brake lamp	The left or right-hand brake lamp is faulty. ► Visit a qualified specialist workshop.
 Left-hand tail lamp/brake lamp or Right-hand tail lamp/brake lamp	The left or right-hand tail lamp/brake lamp is faulty. ► Visit a qualified specialist workshop.





Display messages	Possible causes/consequences and ► Solutions
 Left main beam or Right main beam	<p>The left or right-hand high beam is faulty.</p> <p>► Visit a qualified specialist workshop.</p>
 Number plate lamp	<p>The left or right-hand licence plate lamp is faulty.</p> <p>► Visit a qualified specialist workshop.</p>
 Rear foglamp	<p>The rear foglamp is faulty.</p> <p>► Visit a qualified specialist workshop.</p>
 Front left parking lamp or Front right parking lamp	<p>The front left or front right parking lamp is faulty.</p> <p>► Visit a qualified specialist workshop.</p>
 Reversing light	<p>The reversing lamp is faulty.</p> <p>► Visit a qualified specialist workshop.</p>
 Left-hand daytime driving lamp or Right-hand daytime driving lamp	<p>The left-hand or right-hand daytime driving lamp is faulty.</p> <p>► Visit a qualified specialist workshop.</p>
 Intell. Light Sys- tem inoperative	<p>The Intelligent Light System is faulty. The lights remain available without the Intelligent Light System.</p> <p>► Visit a qualified specialist workshop.</p>
 Malfunction See Owner's Manual	<p>The exterior lighting is faulty.</p> <p>► Visit a qualified specialist workshop.</p>
 AUTO lights inoper- ative	<p>The light sensor is faulty.</p> <p>► Visit a qualified specialist workshop.</p>
 Switch off lights	<p>The lights are still switched on when you leave the vehicle. A warning tone also sounds.</p> <p>► Turn the light switch to AUTO.</p>



Display messages	Possible causes/consequences and ► Solutions
Adaptive Main-beam Assist inoperative	Adaptive Highbeam Assist is faulty. ► Visit a qualified specialist workshop.
Adaptive Main-beam Assist currently unavailable See Owner's Manual	Adaptive Highbeam Assist is deactivated and temporarily inoperative. Possible causes: <ul style="list-style-type: none"> • the windscreen is dirty in the camera's field of vision. • visibility is impaired due to heavy rain, snow or fog. ► Clean the windscreen. If the system detects that the camera is fully operational again, the Adaptive Main-beam Assist available again message is displayed. Adaptive Highbeam Assist is operational again.



Engine

Display messages	Possible causes/consequences and ► Solutions
 Top up coolant See Owner's Manual	The coolant level is too low. ! Avoid making long journeys with too little coolant in the engine cooling system. The engine will otherwise be damaged. ► Top up the coolant, observing the warning notes before doing so (> page 533). ► If the coolant needs topping up more often than usual, have the engine coolant system checked at a qualified specialist workshop.
	The fan motor is faulty. ► If the coolant temperature is below 120 °C, drive to the nearest qualified specialist workshop. ► Avoid heavy loads on the engine as you do so, e.g. driving in mountainous terrain and stop-start traffic.

Display messages	Possible causes/consequences and ► Solutions
 <p data-bbox="115 228 329 284">Coolant Stop car, turn engine off</p>	<p data-bbox="372 177 600 199">The coolant is too hot.</p> <p data-bbox="372 212 661 234">A warning tone also sounds.</p> <p data-bbox="381 253 535 280">⚠ WARNING</p> <p data-bbox="372 298 1033 379">Never drive with an overheated engine. Driving when your engine is overheated can cause some fluids which may have leaked into the engine compartment to catch fire.</p> <p data-bbox="372 392 1033 443">Steam from an overheated engine can cause serious burns, which can occur just by opening the bonnet.</p> <p data-bbox="372 456 611 478">There is a risk of injury.</p> <ul style="list-style-type: none"> <li data-bbox="372 496 1033 547">► Stop the vehicle immediately, paying attention to road and traffic conditions, and switch off the engine. <li data-bbox="372 560 936 582">► Secure the vehicle against rolling away (▷ page 172). <li data-bbox="372 595 1033 646">► Leave the vehicle and keep a safe distance from the vehicle until the engine has cooled down. <li data-bbox="372 659 986 710">► Make sure that the air supply to the engine radiator is not blocked, e.g. by frozen slush. <li data-bbox="372 722 1033 804">► Do not start the engine again until the display message goes out and the coolant temperature is below 120 °C. The engine may otherwise be damaged. <li data-bbox="372 817 894 839">► Pay attention to the coolant temperature display. <li data-bbox="372 852 1014 903">► If the temperature increases again, visit a qualified specialist workshop immediately. <p data-bbox="372 920 1033 971">Under normal operating conditions and with the specified coolant level, the coolant temperature may rise to 120 °C.</p>

Display messages	Possible causes/consequences and ► Solutions
	<p>The battery is not being charged. A warning tone also sounds.</p> <p>Possible causes:</p> <ul style="list-style-type: none"> • faulty alternator • torn poly-V-belt • a malfunction in the electronics <p>► Stop the vehicle immediately, paying attention to road and traffic conditions, and switch off the engine.</p> <p>► Secure the vehicle against rolling away (▷ page 172).</p> <p>► Open the bonnet.</p> <p>► Check whether the poly-V-belt is torn.</p> <p>If the poly-V-belt is torn:</p> <p>! Do not continue driving. The engine could otherwise overheat.</p> <p>► Consult a qualified specialist workshop.</p> <p>If the poly-V-belt is OK:</p> <p>► Visit a qualified specialist workshop.</p>
 <p>Check eng. oil lev. when next refuelling</p>	<p>The engine oil level has dropped to the minimum level. A warning tone also sounds.</p> <p>► Check the oil level when next refuelling, at the latest (▷ page 532).</p> <p>► If necessary, top up the engine oil (▷ page 532).</p> <p>► Have the engine checked at a qualified specialist workshop if the engine oil needs topping up more often than usual.</p>
 <p>Add 1 litre engine oil when next refuelling</p>	<p>AMG vehicles: the engine oil level is too low.</p> <p>► Check the oil level when next refuelling, at the latest (▷ page 532).</p> <p>► If necessary, top up the engine oil (▷ page 532).</p> <p>► Have the engine checked at a qualified specialist workshop if the engine oil needs topping up more often than usual.</p>
 <p>Reserve fuel level</p>	<p>The fuel level has dropped into the reserve range.</p> <p>► Refuel at the nearest filling station.</p>
	<p>There is only a very small amount of fuel in the fuel tank.</p> <p>► Refuel at the nearest filling station without fail.</p>

Driving systems	
Display messages	Possible causes/consequences and ► Solutions
ABC Malfunction	<p>The ABC function (Active Body Control) is restricted.</p> <p> WARNING</p> <p>The vehicle's suspension tuning characteristics may be affected. There is a risk of an accident.</p> <ul style="list-style-type: none"> ► Do not drive at speeds above 80 km/h. ► Visit a qualified specialist workshop.
ABC Malfunction Stop vehicle	<p>The vehicle level of the ABC is too low.</p> <ul style="list-style-type: none"> ► Pull over and stop the vehicle safely as soon as possible, paying attention to road and traffic conditions. <p>After a few seconds, the vehicle level is adjusted and the display message disappears.</p>
	<p>The vehicle is leaking oil.</p> <p>The display message is shown continuously.</p> <p> WARNING</p> <p>The vehicle's suspension tuning characteristics may be affected. There is a risk of an accident.</p> <ul style="list-style-type: none"> ► Pull over and stop the vehicle safely as soon as possible, paying attention to road and traffic conditions. Do not continue driving under any circumstances. ► Secure the vehicle against rolling away (► page 172). ► Consult a qualified specialist workshop.
	<p>ABC is malfunctioning.</p> <p>The display message is shown continuously.</p> <p> WARNING</p> <p>The suspension tuning characteristics are thus affected. There is a risk of an accident.</p> <ul style="list-style-type: none"> ► Do not drive at speeds above 80 km/h. ► Make only slight steering movements. Otherwise, the front wings or the tyres could be damaged if the steering movement is too large. ► Listen for scraping sounds. ► Visit a qualified specialist workshop.

Display messages	Possible causes/consequences and ► Solutions
 <p>Attention Assist Take a break!</p>	<p>Based on certain criteria, ATTENTION ASSIST has detected fatigue or a lack of concentration on the part of the driver. A warning tone also sounds.</p> <p>► If necessary, take a break.</p> <p>During long journeys, take regular breaks in good time so that you get enough rest.</p>
 <p>Attention Assist inoperative</p>	<p>ATTENTION ASSIST is inoperative.</p> <p>► Visit a qualified specialist workshop.</p>
<p>Speed Limit Assist currently unavail- able See Owner's Manual</p>	<p>Speed Limit Assist is deactivated and temporarily inoperative. Possible causes:</p> <ul style="list-style-type: none"> • the windscreen is dirty in the camera's field of vision. • visibility is impaired due to heavy rain, snow or fog. <p>► Clean the windscreen.</p> <p>If the system detects that the camera is fully operational, the display message disappears.</p> <p>Speed Limit Assist is operational again.</p>
<p>Speed Limit Assist: Unavail- able in this country</p>	<p>Speed Limit Assist is only available in certain countries.</p> <p>► Drive on.</p> <p>Speed Limit Assist is available again as soon as you drive into a country in which its use is approved.</p>
<p>Speed Limit Assist inoperative</p>	<p>Speed Limit Assist is faulty.</p> <p>► Visit a qualified specialist workshop.</p>
 <p>Off</p>	<p>The HOLD function is deactivated. The vehicle is skidding. A warning tone also sounds.</p> <p>► Reactivate the HOLD function later (▷ page 193).</p>
<p>Radar sensor deac- tivated See Own- er's Manual</p>	<p>The radar sensor system is deactivated.</p> <p>► Check whether or not the radar sensor system may be activated (▷ page 595).</p> <p>► Switch on the radar sensor system (▷ page 237).</p>

Display messages	Possible causes/consequences and ► Solutions
<p>Active Lane Keeping Assist currently unavailable See Owner's Manual</p>	<p>Active Lane Keeping Assist is deactivated and temporarily inoperative. Possible causes:</p> <ul style="list-style-type: none"> • the windscreen is dirty in the camera's field of vision. • visibility is impaired due to heavy rain, snow or fog. • there are no lane markings for a longer period. • the lane markings are worn, dark or covered, e.g. by dirt or snow. <p>Once the causes listed above no longer apply, the display message goes out.</p> <p>Active Lane Keeping Assist is operational again.</p> <p>If the display message does not disappear:</p> <ul style="list-style-type: none"> ► Pull over and stop the vehicle safely as soon as possible, paying attention to road and traffic conditions. ► Secure the vehicle against rolling away (▷ page 172). ► Clean the windscreen.
<p>Active Lane Keeping Assist inoperative</p>	<p>Active Lane Keeping Assist is faulty.</p> <ul style="list-style-type: none"> ► Visit a qualified specialist workshop.
<p>Active Blind Spot Assist currently unavailable See Owner's Manual</p>	<p>Active Blind Spot Assist is temporarily inoperative. Possible causes:</p> <ul style="list-style-type: none"> • the sensors are dirty. • the function is impaired due to heavy rain or snow. • the radar sensor system is outside the operating temperature range. • the radar sensor system is temporarily inoperative, e.g. due to electromagnetic radiation emitted by nearby TV or radio stations or other sources of electromagnetic radiation. <p>The yellow  indicator lamps also light up in the exterior mirrors.</p> <p>Once the causes listed above no longer apply, the display message goes out.</p> <p>Active Blind Spot Assist is operational again.</p> <p>If the display message does not disappear:</p> <ul style="list-style-type: none"> ► Pull over and stop the vehicle safely as soon as possible, paying attention to road and traffic conditions. ► Secure the vehicle against rolling away (▷ page 172). ► Clean the sensors (▷ page 539). ► Restart the engine.

Display messages	Possible causes/consequences and ► Solutions
Active Blind Spot Assist inoperative	<p>Active Blind Spot Assist is faulty.</p> <p>The yellow  indicator lamps also light up in the exterior mirrors.</p> <p>► Visit a qualified specialist workshop.</p>
Park Assist cancelled	<p>The driver's door is open and the driver's seat belt has not been fastened.</p> <p>► Repeat the parking process with the seat belt fastened and the driver's door closed.</p> <p>You inadvertently touched the multifunction steering wheel while steering intervention was active.</p> <p>► While steering intervention is active, make sure not to touch the multifunction steering wheel.</p> <p>The vehicle has started to skid and ESP® has intervened.</p> <p>► Use Active Parking Assist again later (▷ page 204).</p>
Park Assist inoperative	<p>You have just carried out a large number of turning or parking manoeuvres.</p> <p>Active Parking Assist will become available again after approximately ten minutes (▷ page 204).</p> <p>► Pull over and stop the vehicle safely as soon as possible, paying attention to road and traffic conditions.</p> <p>► Switch off and restart the engine.</p> <p>If the display message continues to be displayed:</p> <p>► Visit a qualified specialist workshop.</p> <p>PARKTRONIC is faulty.</p> <p>► Visit a qualified specialist workshop.</p>
Park Assist switched off	<p>The vehicle is parked. A warning tone also sounds.</p> <p>The display message disappears automatically.</p>
DISTRONIC PLUS off	<p>DISTRONIC PLUS has been deactivated (▷ page 181).</p> <p>If it was deactivated automatically, a warning tone also sounds.</p>
DISTRONIC PLUS available again	<p>DISTRONIC PLUS is operational again after having been temporarily unavailable. You can now reactivate DISTRONIC PLUS (▷ page 181).</p>





Display messages	Possible causes/consequences and ► Solutions
<p>DISTRONIC PLUS currently unavailable See Owner's Manual</p>	<p>DISTRONIC PLUS is temporarily inoperative. Possible causes:</p> <ul style="list-style-type: none"> • the function is impaired due to heavy rain or snow. • the sensors in the radiator trim and in the bumpers are dirty. • the radar sensor system is temporarily inoperative, e.g. due to electromagnetic radiation emitted by nearby TV or radio stations or other sources of electromagnetic radiation. • the system is outside the operating temperature range. • the on-board voltage is too low. <p>A warning tone also sounds.</p> <p>Once the causes listed above no longer apply, the display message goes out.</p> <p>DISTRONIC is operational again.</p> <p>If the display message does not disappear:</p> <ul style="list-style-type: none"> ► Pull over and stop the vehicle safely as soon as possible, paying attention to road and traffic conditions. ► Secure the vehicle against rolling away (▷ page 172). ► Clean the sensors in the radiator grille and the bumper (▷ page 539). ► Restart the engine.
<p>DISTRONIC PLUS inoperative</p>	<p>DISTRONIC PLUS is faulty.</p> <p>BAS PLUS and PRE-SAFE® Brake may also have failed.</p> <p>A warning tone also sounds.</p> <ul style="list-style-type: none"> ► Visit a qualified specialist workshop.
<p>DISTRONIC PLUS inactive</p>	<p>You have depressed the accelerator pedal. DISTRONIC PLUS is no longer controlling the speed of the vehicle.</p> <ul style="list-style-type: none"> ► Remove your foot from the accelerator pedal.
<p>DISTRONIC PLUS --- km/h</p>	<p>An activation condition for DISTRONIC PLUS is not fulfilled.</p> <ul style="list-style-type: none"> ► Check the activation conditions for DISTRONIC PLUS (▷ page 181).
<p>DISTRONIC PLUS and SPEEDTRONIC inoperative</p>	<p>DISTRONIC PLUS and SPEEDTRONIC are faulty. A warning tone also sounds.</p> <ul style="list-style-type: none"> ► Visit a qualified specialist workshop.
<p>Cruise control and SPEEDTRONIC inoperative</p>	<p>SPEEDTRONIC and cruise control are malfunctioning.</p> <p>A warning tone also sounds.</p> <ul style="list-style-type: none"> ► Visit a qualified specialist workshop.

Display messages	Possible causes/consequences and ► Solutions
Limit --- km/h	While depressing the accelerator pedal beyond the pressure point (kickdown), SPEEDTRONIC cannot be activated.
Cruise control --- km/h	A condition for activating cruise control has not been met. You have tried to store a speed below 30 km/h, for example. <ul style="list-style-type: none"> ► If conditions permit, drive faster than 30 km/h and store the speed. ► Check the activation conditions for cruise control (> page 178).
120 km/h Maximum speed exceeded	Only for certain countries: the maximum speed has been exceeded. In addition, the multifunction display shows 120 km/h. <ul style="list-style-type: none"> ► Drive more slowly.







Tyres	
Display messages	Possible causes/consequences and ► Solutions
Tyre pressure Check tyres	<p>The tyre pressure loss warning system has detected a significant loss in pressure.</p> <p>A warning tone also sounds.</p> <p> WARNING</p> <p>With tyre pressures which are too low, there is a risk of the following hazards:</p> <ul style="list-style-type: none"> • the tyres may burst, especially as the load and vehicle speed increase. • the tyres may wear excessively and/or unevenly, which may greatly impair tyre traction. • The driving characteristics, as well as steering and braking, may be greatly impaired. <p>There is a risk of an accident.</p> <ul style="list-style-type: none"> ► Stop the vehicle without making any sudden steering or braking manoeuvres. Pay attention to the traffic conditions as you do so. ► Secure the vehicle against rolling away (► page 172). ► If there is a flat tyre, inspect the tyres (► page 546). ► Check the tyre pressures and, if necessary, correct the tyre pressure. ► Restart the tyre pressure loss warning system when the tyre pressure is correct (► page 567).
Check tyre pressures then restart Run Flat Indicator	<p>The tyre pressure loss warning system generated a display message and has not been restarted since.</p> <ul style="list-style-type: none"> ► Set the correct tyre pressure in all four tyres. ► Restart the tyre pressure loss warning system (► page 567).
Run Flat Indicator inoperative	<p>The tyre pressure loss warning system is faulty.</p> <ul style="list-style-type: none"> ► Visit a qualified specialist workshop.
Tyre pressures will be displayed after a few minutes of driving	<p>The tyre pressure monitor is measuring the tyre pressure.</p> <ul style="list-style-type: none"> ► Drive on. <p>The tyre pressures appear in the multifunction display after you have been driving for a few minutes.</p>
Tyre press. monitor inoperative	<p>The tyre pressure monitor is faulty.</p> <ul style="list-style-type: none"> ► Visit a qualified specialist workshop.





Display messages	Possible causes/consequences and ► Solutions
Tyre press. monitor inoperative No wheel sensors	<p>The wheels fitted do not have a suitable tyre pressure sensor. The tyre pressure monitor is deactivated.</p> <p>► Fit wheels with suitable tyre pressure sensors. The tyre pressure monitor is activated automatically after driving for a few minutes.</p>
Check tyre(s)	<p>The tyre pressure in one or more tyres has dropped significantly. The wheel position is displayed in the multifunction display. A warning tone also sounds.</p> <p> WARNING</p> <p>With tyre pressures which are too low, there is a risk of the following hazards:</p> <ul style="list-style-type: none"> • the tyres may burst, especially as the load and vehicle speed increase. • the tyres may wear excessively and/or unevenly, which may greatly impair tyre traction. • The driving characteristics, as well as steering and braking, may be greatly impaired. <p>There is a risk of an accident.</p> <p>► Stop the vehicle without making any sudden steering or braking manoeuvres. Pay attention to the traffic conditions as you do so.</p> <p>► Secure the vehicle against rolling away (▷ page 172).</p> <p>► If there is a flat tyre, inspect the tyres (▷ page 546).</p> <p>► Check the tyre pressure (▷ page 568).</p> <p>► If necessary, correct the tyre pressure.</p>







Display messages	Possible causes/consequences and ► Solutions
Warning tyre defect	<p>The tyre pressure in one or more tyres has dropped suddenly. The wheel position is displayed in the multifunction display.</p> <p> WARNING</p> <p>If you drive with a flat tyre, there is a risk of the following hazards:</p> <ul style="list-style-type: none"> • a flat tyre affects the ability to steer or brake the vehicle. • you could lose control of the vehicle. • continued driving with a flat tyre will cause excessive heat build-up and possibly a fire. <p>There is a risk of an accident.</p> <ul style="list-style-type: none"> ► Stop the vehicle without making any sudden steering or braking manoeuvres. Pay attention to the traffic conditions as you do so. ► Secure the vehicle against rolling away (▷ page 172). ► If there is a flat tyre, inspect the tyres (▷ page 546).
Rectify tyre pressure	<p>The tyre pressure is too low in at least one of the tyres, or the tyre pressure difference between the wheels is too great.</p> <ul style="list-style-type: none"> ► Check the tyre pressures at the next opportunity (▷ page 568). ► If necessary, correct the tyre pressure. ► Restart the tyre pressure monitor (▷ page 569).
Wheel sensor(s) missing	<p>There is no signal from the tyre pressure sensor of one or several wheels. The pressure of the affected tyre is not displayed in the multifunction display.</p> <ul style="list-style-type: none"> ► Have the faulty tyre pressure sensor replaced at a qualified specialist workshop.
Tyre press. monitor currently unavail- able	<p>Due to a source of radio interference, no signals can be received from the wheel sensors. The tyre pressure monitor is temporarily malfunctioning.</p> <ul style="list-style-type: none"> ► Drive on. <p>The tyre pressure monitor restarts automatically as soon as the cause has been rectified.</p>



Display messages	Possible causes/consequences and ► Solutions
 <p>Tyre pressure Caution Tyre malfunction</p>	<p>The tyre pressure in one or more tyres has dropped suddenly. A warning tone also sounds.</p> <p> WARNING</p> <p>If you drive with a flat tyre, there is a risk of the following hazards:</p> <ul style="list-style-type: none"> • a flat tyre affects the ability to steer or brake the vehicle. • you could lose control of the vehicle. • continued driving with a flat tyre will cause excessive heat build-up and possibly a fire. <p>There is a risk of an accident.</p> <p>► Stop the vehicle without making any sudden steering or braking manoeuvres. Pay attention to the traffic conditions as you do so.</p> <p>► Secure the vehicle against rolling away (▷ page 172).</p> <p>► If there is a flat tyre, inspect the tyres (▷ page 546).</p>
 <p>Tyre pressure Check tyre(s)</p>	<p>The tyre pressure in one or more tyres has dropped significantly.</p> <p> WARNING</p> <p>With tyre pressures which are too low, there is a risk of the following hazards:</p> <ul style="list-style-type: none"> • the tyres may burst, especially as the load and vehicle speed increase. • the tyres may wear excessively and/or unevenly, which may greatly impair tyre traction. • the driving characteristics, as well as steering and braking, may be greatly impaired. <p>There is a risk of an accident.</p> <p>► Stop the vehicle without making any sudden steering or braking manoeuvres. Pay attention to the traffic conditions as you do so.</p> <p>► Secure the vehicle against rolling away (▷ page 172).</p> <p>► If there is a flat tyre, inspect the tyres (▷ page 546).</p> <p>► Check the tyre pressure (▷ page 568).</p> <p>► If necessary, correct the tyre pressure.</p>
 <p>Please correct tyre pressure</p>	<p>The tyre pressure is too low in at least one of the tyres, or the tyre pressure difference between the wheels is too great.</p> <p>► Check the tyre pressures at the next opportunity (▷ page 568).</p> <p>► If necessary, correct the tyre pressure.</p>

Vehicle	
Display messages	Possible causes/consequences and ► Solutions
To start engine, shift to either P or N	You have attempted to start the engine with the transmission in position R or D . ► Shift the transmission to position P or N .
Auxiliary battery malfunction	The auxiliary battery for the automatic transmission is no longer being charged. ► Visit a qualified specialist workshop at the next opportunity. ► Until then, set the automatic transmission to position P before you switch off the engine. ► Before leaving the vehicle, apply the electric parking brake. ► Secure the vehicle against rolling away (▷ page 172).
Apply brake to deselect Park (P) position	You have attempted to move the transmission selector lever to position D , R or N without depressing the brake pedal. ► Depress the brake pedal.
Vehicle not in position P	The driver's door is open and the transmission is in position R , N or D . A warning tone also sounds. ► Shift the transmission to position P . ► Secure the vehicle against rolling away (▷ page 172).
Without changing gear, consult workshop	You cannot change the transmission position due to a malfunction. A warning tone also sounds. If transmission position D is selected: ► Drive to a qualified specialist workshop without shifting the transmission from position D . If transmission position R , N or P is selected: ► Consult a qualified specialist workshop.
Only select Park (P) when vehicle is stationary	The vehicle is moving. ► Pull over and stop the vehicle safely as soon as possible, paying attention to road and traffic conditions. ► Shift the transmission to position P .
	The boot lid is open. ► Close the boot lid.

Display messages	Possible causes/consequences and ► Solutions
	<p>The bonnet is open. A warning tone also sounds.</p> <p> WARNING</p> <p>The open bonnet may then block your view when the vehicle is in motion. There is a risk of an accident.</p> <ul style="list-style-type: none"> ► Pull over and stop the vehicle safely as soon as possible, paying attention to road and traffic conditions. ► Secure the vehicle against rolling away (▷ page 172). ► Close the bonnet.
<p>Active bonnet mal- function See Own- er's Manual</p>	<p>The active bonnet (pedestrian protection) is not active due to a malfunction or because it has already been triggered.</p> <ul style="list-style-type: none"> ► Visit a qualified specialist workshop.
	<p>At least one door is open. A warning tone also sounds.</p> <ul style="list-style-type: none"> ► Close all doors.
<p> Power steering mal- function See Own- er's Manual</p>	<p>The power steering assistance is faulty. A warning tone also sounds.</p> <p> WARNING</p> <p>You will need to use more force to steer. There is a risk of an accident.</p> <ul style="list-style-type: none"> ► Check whether you are able to apply the extra force required. ► If you are able to steer safely: carefully drive on to a qualified specialist workshop. ► If you are unable to steer safely: do not drive on. Contact the nearest qualified specialist workshop.
<p> Close boot separa- tor</p>	<p>The boot separator is open.</p> <ul style="list-style-type: none"> ► Close the boot separator (▷ page 105).
<p> Close centre com- partment</p>	<p>The stowage space under the armrest is open. The interior motion sensor is not primed.</p> <ul style="list-style-type: none"> ► Close the stowage space under the armrest (▷ page 513).

Display messages	Possible causes/consequences and ► Solutions
Telephone No service	Your vehicle is outside the network provider's transmitter/receiver range. ► Wait until the mobile phone operational readiness symbol appears in the multifunction display.
 Decrease speed	You wanted to open the roof while the vehicle was in motion. ► Pull over and stop the vehicle safely as soon as possible, paying attention to road and traffic conditions. ► Open the roof (▷ page 103).
 Vario-roof lowering	The roof is not fully opened or closed. The hydraulics are depressurised. ► Fully open or close the roof (▷ page 103).
 Open/close vario-roof completely	The roof is not locked. ► Pull over and stop the vehicle safely as soon as possible, paying attention to road and traffic conditions. ► Push or pull the roof switch until the roof is fully open or closed (▷ page 103).
 Start engine See Owner's Manual	The on-board voltage is too low. ► Start the engine.
	The roof has been opened and closed several times in a row. The roof drive has been switched off automatically for safety reasons. You can open and close the roof again after approximately ten minutes. ► Switch off the ignition and turn it back on. ► Repeat the opening or closing procedure (▷ page 103).
 Top up washer fluid	The washer fluid level in the washer fluid reservoir has dropped below the minimum. ► Top up the washer fluid (▷ page 534).
Wiper malfunctioning	The windscreen wipers are defective. ► Visit a qualified specialist workshop.
Hazard warning lamps malfunctioning	The hazard warning lamps are faulty. ► Visit a qualified specialist workshop.



Key	
Display messages	Possible causes/consequences and ► Solutions
 Key does not belong to vehicle	You have put the wrong key in the ignition lock. ► Use the correct key.
 Replace key	The key needs to be replaced. ► Visit a qualified specialist workshop.
 Change key batteries	The batteries of the KEYLESS-GO key are discharged. ► Change the batteries (► page 87).
 Key not detected (red display message)	The KEYLESS-GO key is not in the vehicle. A warning tone also sounds. If the engine is switched off, you can no longer lock the vehicle centrally or start the engine. ► Pull over and stop the vehicle safely as soon as possible, paying attention to road and traffic conditions. ► Secure the vehicle against rolling away (► page 172). ► Locate the KEYLESS-GO key.
	The KEYLESS-GO key is not detected while the engine is running because there is interference from a strong source of radio waves. A warning tone also sounds. ► Pull over and stop the vehicle safely as soon as possible, paying attention to road and traffic conditions. ► Secure the vehicle against rolling away (► page 172). ► Operate the vehicle with the key in the ignition lock if necessary.
 Key not detected (white display message)	The KEYLESS-GO key cannot be detected at present. ► Change the location of the key with the KEYLESS-GO functions in the vehicle. If the KEYLESS-GO key is still not detected: ► Operate the vehicle with the key in the ignition lock if necessary.
 Key still in vehicle	The KEYLESS-GO key has been detected inside the vehicle during locking. ► Remove the KEYLESS-GO key from the vehicle.

Display messages	Possible causes/consequences and ► Solutions
 <p>Remove starting button, then insert key</p>	<p>The KEYLESS-GO key is not continually detected. KEYLESS-GO is temporarily malfunctioning or is defective. A warning tone also sounds.</p> <ul style="list-style-type: none"> ► Insert the key into the ignition lock and turn it to the desired position. ► Visit a qualified specialist workshop.
 <p>Close doors to lock vehicle</p>	<p>At least one door is open. A warning tone also sounds.</p> <ul style="list-style-type: none"> ► Close all doors and lock the vehicle again.

Warning and indicator lamps





Safety



Seat belts







Problem	Possible causes/consequences and ► Solutions
 <p>Only for certain countries: the red seat belt warning lamp lights up for six seconds after the engine starts.</p>	<p>The seat belt warning lamp reminds the driver and front passenger to fasten their seat belts.</p> <ul style="list-style-type: none"> ► Fasten your seat belt (► page 62).
 <p>Only for certain countries: the red seat belt warning lamp lights up after the engine starts. In addition, a warning tone sounds for up to six seconds.</p>	<p>The driver's seat belt is not fastened.</p> <ul style="list-style-type: none"> ► Fasten your seat belt (► page 62). The warning tone ceases.
 <p>The red seat belt warning lamp lights up after the engine starts, as soon as the driver's or the front-passenger door is closed.</p>	<p>The driver or passenger has not fastened their seat belt.</p> <ul style="list-style-type: none"> ► Fasten your seat belt (► page 62). The warning lamp goes out. <p>There are objects on the front-passenger seat.</p> <ul style="list-style-type: none"> ► Remove the objects from the front-passenger seat and stow them in a secure place. The warning lamp goes out.





Problem	Possible causes/consequences and ► Solutions
 <p>The red seat belt warning lamp flashes and an intermittent audible warning sounds.</p>	<p>The driver or passenger has not fastened their seat belt. At the same time, the car is being driven faster than 25 km/h or has been briefly driven faster than 25 km/h.</p> <p>► Fasten your seat belt (► page 62). The warning lamp goes out and the intermittent warning tone ceases.</p> <p>There are objects on the front-passenger seat. At the same time, the car is being driven faster than 25 km/h or has been briefly driven faster than 25 km/h.</p> <p>► Remove the objects from the front-passenger seat and stow them in a secure place. The warning lamp goes out and the intermittent warning tone ceases.</p>





Safety systems



Problem	Possible causes/consequences and ► Solutions
 <p>The red brake system warning lamp comes on while the engine is running. A warning tone also sounds.</p>	<p>There is insufficient brake fluid in the brake fluid reservoir.</p> <p> WARNING</p> <p>The braking efficiency may be impaired. There is a risk of an accident.</p> <ul style="list-style-type: none"> ► Pull over and stop the vehicle safely as soon as possible, paying attention to road and traffic conditions. Do not continue driving under any circumstances. ► Secure the vehicle against rolling away (► page 172). ► Do not top up the brake fluid. Topping up will not rectify the fault. ► Consult a qualified specialist workshop. ► Observe the additional display messages in the multifunction display.
 <p>The yellow ABS warning lamp is lit while the engine is running.</p>	<p>ABS (Anti-lock Brake System) has been deactivated due to a fault. For this reason, BAS (Brake Assist), BAS PLUS, ESP® (Electronic Stability Program), PRE-SAFE®, PRE-SAFE® Brake, the HOLD function, hill start assist and the adaptive brake lights are also deactivated, for example.</p> <p>ATTENTION ASSIST is deactivated.</p> <p> WARNING</p> <p>The brake system continues to function normally, but without the functions listed above. The wheels could therefore lock if you brake hard, for example.</p> <p>The steerability and braking characteristics may be severely affected. The braking distance in an emergency braking situation can increase.</p> <p>If ESP® is not operational, ESP® is unable to stabilise the vehicle. The danger of skidding and having an accident increases.</p> <ul style="list-style-type: none"> ► Observe the additional display messages in the multifunction display. ► Drive on carefully. ► Visit a qualified specialist workshop. <p>If the ABS control unit is faulty, there is also a possibility that other systems, such as the navigation system or the automatic transmission, will not be available.</p>

Problem	Possible causes/consequences and ► Solutions
 <p>The yellow ABS warning lamp is lit while the engine is running.</p>	<p>ABS is temporarily unavailable. Therefore, BAS, BAS PLUS, ESP[®], EBD (electronic brake force distribution), PRE-SAFE[®], PRE-SAFE[®] Brake, the HOLD function, hill start assist and the adaptive brake lights, for example, are also deactivated.</p> <p>Possible causes:</p> <ul style="list-style-type: none"> • self-diagnosis is not yet complete. • the on-board voltage may be insufficient. <p>ATTENTION ASSIST is deactivated.</p> <p> WARNING</p> <p>The brake system continues to function normally, but without the functions listed above. The front and rear wheels could therefore lock if you brake hard, for example.</p> <p>The steerability and braking characteristics may be severely affected. The braking distance in an emergency braking situation can increase.</p> <p>If ESP[®] is not operational, ESP[®] is unable to stabilise the vehicle. There is a risk of an accident.</p> <p>► Carefully drive on a suitable stretch of road, making slight steering movements at a speed above 20 km/h. The functions mentioned above are available again when the warning lamp goes out.</p> <p>If the warning lamp is still on:</p> <ul style="list-style-type: none"> ► Observe the additional display messages in the multifunction display. ► Drive on carefully. ► Visit a qualified specialist workshop.



Problem	Possible causes/consequences and ► Solutions
 <p>The yellow ABS warning lamp is lit while the engine is running. A warning tone also sounds.</p>	<p>EBD is not available due to a malfunction. Therefore, ABS, BAS, BAS PLUS, ESP[®], PRE-SAFE[®], PRE-SAFE[®] Brake, the HOLD function, hill start assist and the adaptive brake lights, for example, are not available either.</p> <p>ATTENTION ASSIST is deactivated.</p> <p> WARNING</p> <p>The brake system continues to function normally, but without the functions listed above. The front and rear wheels could therefore lock if you brake hard, for example.</p> <p>The steerability and braking characteristics may be severely affected. The braking distance in an emergency braking situation can increase.</p> <p>If ESP[®] is not operational, ESP[®] is unable to stabilise the vehicle. The danger of skidding and having an accident increases.</p> <ul style="list-style-type: none"> ► Observe the additional display messages in the multifunction display. ► Drive on carefully. ► Visit a qualified specialist workshop.
    <p>The red brake warning lamp, the yellow ESP[®] and ESP[®] OFF warning lamps and the yellow ABS warning lamp are lit while the engine is running.</p>	<p>ABS and ESP[®] are not available due to a fault. Therefore, BAS, BAS PLUS, EBD, PRE-SAFE[®], PRE-SAFE[®] Brake, the HOLD function, hill start assist and the adaptive brake lights, for example, are not available either.</p> <p>ATTENTION ASSIST is deactivated.</p> <p> WARNING</p> <p>The brake system continues to function normally, but without the functions listed above. The front and rear wheels could therefore lock if you brake hard, for example.</p> <p>The steerability and braking characteristics may be severely affected. The braking distance in an emergency braking situation can increase.</p> <p>If ESP[®] is not operational, ESP[®] is unable to stabilise the vehicle. The danger of skidding and having an accident increases.</p> <ul style="list-style-type: none"> ► Observe the additional display messages in the multifunction display. ► Drive on carefully. ► Visit a qualified specialist workshop.

Problem	Possible causes/consequences and ► Solutions
 <p>The yellow ESP® warning lamp flashes while the vehicle is in motion.</p>	<p>ESP® or traction control has intervened because there is a risk of skidding or at least one wheel has started to spin. Cruise control or DISTRONIC PLUS is deactivated.</p> <ul style="list-style-type: none"> ► Only depress the accelerator pedal as far as necessary when pulling away. ► Accelerate more gently while the vehicle is in motion. ► Adapt your driving style to suit the road and weather conditions. ► Do not deactivate ESP®. <p>For exceptions; see: (▷ page 75).</p>
 <p>The yellow ESP® OFF warning lamp is lit while the engine is running.</p>	<p>ESP® is deactivated.</p> <p> WARNING</p> <p>If ESP® is switched off, ESP® is unable to stabilise the vehicle. The danger of skidding and having an accident increases.</p> <ul style="list-style-type: none"> ► Reactivate ESP®. <p>For exceptions; see: (▷ page 75).</p> <ul style="list-style-type: none"> ► Adapt your driving style to suit the road and weather conditions. <p>If ESP® cannot be activated:</p> <ul style="list-style-type: none"> ► Drive on carefully. ► Have ESP® checked at a qualified specialist workshop.
 <p>AMG vehicles only: The yellow SPORT handling mode warning lamp is lit while the engine is running.</p>	<p>SPORT handling mode is activated.</p> <p> WARNING</p> <p>When SPORT handling mode is switched on, ESP® is unable to stabilise the vehicle. The danger of skidding and having an accident increases.</p> <ul style="list-style-type: none"> ► Only switch on SPORT handling mode in certain situations (▷ page 76).



Problem	Possible causes/consequences and ► Solutions
 <p>The yellow ESP® and ESP® OFF warning lamps are lit while the engine is running.</p>	<p>ESP®, BAS, BAS PLUS, PRE-SAFE®, PRE-SAFE® Brake, the HOLD function, hill start assist and the adaptive brake lights are not available due to a malfunction. ATTENTION ASSIST is deactivated.</p> <p> WARNING</p> <p>The brake system continues to function normally, but without the functions listed above. The braking distance in an emergency braking situation can thus increase. If ESP® is not operational, ESP® is unable to stabilise the vehicle. The danger of skidding and having an accident increases.</p> <ul style="list-style-type: none"> ► Observe the additional display messages in the multifunction display. ► Drive on carefully. ► Visit a qualified specialist workshop.
 <p>The yellow ESP® and ESP® OFF warning lamps are lit while the engine is running.</p>	<p>ESP®, BAS, PRE-SAFE®, the HOLD function and hill start assist are temporarily unavailable. The adaptive brake lights, BAS PLUS and PRE-SAFE® Brake may also have failed. ATTENTION ASSIST is deactivated. self-diagnosis is not yet complete.</p> <p> WARNING</p> <p>The brake system continues to function normally, but without the functions listed above. The braking distance in an emergency braking situation can thus increase. If ESP® is not operational, ESP® is unable to stabilise the vehicle. The danger of skidding and having an accident increases.</p> <ul style="list-style-type: none"> ► Carefully drive on a suitable stretch of road, making slight steering movements at a speed above 20 km/h. The functions mentioned above are available again when the warning lamp goes out. <p>If the warning lamp is still on:</p> <ul style="list-style-type: none"> ► Observe the additional display messages in the multifunction display. ► Drive on carefully. ► Visit a qualified specialist workshop.

Problem	Possible causes/consequences and ► Solutions
 <p>The red indicator lamp for the electric parking brake flashes or lights up and/or the yellow warning lamp for the electric parking brake lights up.</p>	<p>► Observe the additional display messages in the multifunction display.</p>
 <p>The red SRS warning lamp is lit while the engine is running.</p>	<p>There is a malfunction in the SRS (Supplemental Restraint System).</p> <p> WARNING</p> <p>The airbags or belt tensioners may either be triggered unintentionally or, in the event of an accident, may not be triggered. This poses an increased risk of injury.</p> <p>► Drive on carefully.</p> <p>► Have SRS checked at a qualified specialist workshop immediately.</p> <p>For further information about the Supplemental Restraint System; see (> page 55).</p>

Engine



Problem	Possible causes/consequences and ► Solutions
 <p>The yellow engine diagnostics warning lamp lights up while the engine is running.</p>	<p>There may be a fault, for example:</p> <ul style="list-style-type: none"> • in the engine management • in the fuel injection system • in the exhaust system • in the ignition system • in the fuel system <p>The emission limit values may be exceeded and the engine may be running in emergency mode.</p> <p>► Have the vehicle checked as soon as possible at a qualified specialist workshop.</p>
 <p>The yellow reserve fuel warning lamp lights up while the engine is running.</p>	<p>The fuel level has dropped into the reserve range.</p> <p>► Refuel at the nearest filling station.</p>



Problem	Possible causes/consequences and ► Solutions
 <p>The red coolant warning lamp lights up while the engine is running and the coolant temperature gauge is at the start of the scale.</p>	<p>The temperature sensor for the coolant temperature gauge is faulty.</p> <p>The coolant temperature is no longer being monitored. There is a risk of engine damage if the coolant temperature is too high.</p> <ul style="list-style-type: none">► Stop the vehicle immediately, paying attention to road and traffic conditions, and switch off the engine. Do not continue driving under any circumstances.► Secure the vehicle against rolling away (▷ page 172).► Consult a qualified specialist workshop.

Problem	Possible causes/consequences and ► Solutions
 <p>The red coolant warning lamp comes on while the engine is running.</p>	<p>The coolant level is too low.</p> <p>If the coolant level is correct, the airflow to the engine radiator may be blocked or the electric engine radiator fan may be malfunctioning.</p> <p>The coolant is too hot and the engine is no longer being cooled sufficiently.</p> <ul style="list-style-type: none"> ► Observe the additional display messages in the multifunction display. ► Stop the vehicle immediately, paying attention to road and traffic conditions, and switch off the engine. ► Secure the vehicle against rolling away (▷ page 172). ► Leave the vehicle and keep a safe distance from the vehicle until the engine has cooled down. ► Check the coolant level and top up the coolant, observing the warning notes (▷ page 533). ► If you have to top up the coolant frequently, have the engine cooling system checked. ► Make sure that the air supply to the engine radiator is not blocked, e.g. by frozen slush. ► Do not start the engine again until the coolant temperature is below 120 °C. The engine may otherwise be damaged. ► Drive to the nearest qualified specialist workshop. ► Avoid heavy loads on the engine as you do so, e.g. driving in mountainous terrain and stop-start traffic.
 <p>The red coolant warning lamp comes on while the engine is running. A warning tone also sounds.</p>	<p>The coolant temperature has exceeded 120 °C. The airflow to the engine radiator may be blocked or the coolant level may be too low.</p> <p> WARNING</p> <p>The engine is not being cooled sufficiently and may be damaged. Never drive with an overheated engine. Driving when your engine is overheated can cause some fluids which may have leaked into the engine compartment to catch fire.</p> <p>Steam from an overheated engine can cause serious burns, which can occur just by opening the bonnet.</p> <p>There is a risk of injury.</p> <ul style="list-style-type: none"> ► Observe the additional display messages in the multifunction display. ► Stop the vehicle immediately, paying attention to road and traffic conditions, and switch off the engine. ► Secure the vehicle against rolling away (▷ page 172).

Problem	Possible causes/consequences and ► Solutions
	<ul style="list-style-type: none"> ► Leave the vehicle and keep a safe distance from the vehicle until the engine has cooled down. ► Check the coolant level and top up the coolant, observing the warning notes (▷ page 533). ► If you have to top up the coolant frequently, have the engine cooling system checked. ► Make sure that the air supply to the engine radiator is not blocked, e.g. by frozen slush. ► If the coolant temperature is below 120 °C, you can continue driving to the nearest qualified specialist workshop. ► Avoid heavy loads on the engine as you do so, e.g. driving in mountainous terrain and stop-start traffic.

Driving systems

Problem	Possible causes/consequences and ► Solutions
 <p>The red distance warning lamp lights up while the vehicle is in motion.</p>	<p>The distance to the vehicle in front is too small for the speed selected.</p> <ul style="list-style-type: none"> ► Increase the distance.
 <p>The red distance warning lamp lights up while the vehicle is in motion. A warning tone also sounds.</p>	<p>You are approaching a vehicle or a stationary obstacle in your line of travel at too high a speed.</p> <ul style="list-style-type: none"> ► Be prepared to brake immediately. ► Pay careful attention to the traffic situation. You may have to brake or take evasive action. <p>Further information on DISTRONIC PLUS (▷ page 182). Further information on PRE-SAFE® Brake (▷ page 78).</p>

Tyres	
Problem	Possible causes/consequences and ► Solutions
 <p>The yellow tyre pressure monitor warning lamp is on.</p>	<p>The tyre pressure monitor has detected a loss of pressure in at least one of the tyres.</p> <p> WARNING</p> <p>With tyre pressures which are too low, there is a risk of the following hazards:</p> <ul style="list-style-type: none"> • the tyres may burst, especially as the load and vehicle speed increase. • the tyres may wear excessively and/or unevenly, which may greatly impair tyre traction. • the driving characteristics, as well as steering and braking, may be greatly impaired. <p>There is a risk of an accident.</p> <ul style="list-style-type: none"> ► Stop the vehicle without making any sudden steering or braking manoeuvres. Pay attention to the traffic conditions as you do so. ► Secure the vehicle against rolling away (▷ page 172). ► Observe the additional display messages in the multifunction display. ► If there is a flat tyre, inspect the tyres (▷ page 546). ► Check the tyre pressure (▷ page 568). ► If necessary, correct the tyre pressure.

Useful information	282
Operating safety	282
At a glance	283
System settings	303
Vehicle functions	308
Navigation	314
Telephone	378
Online and Internet functions	418
Audio	453
Video	492

Useful information

i These Operating Instructions describe all the standard and optional equipment of your COMAND Online system, as available at the time of going to print. Country-specific differences are possible. Please note that your COMAND Online system may not be equipped with all the features described. This is also the case for systems and functions relevant to safety.

i Read the information on qualified specialist workshops: (▷ page 38).

Operating safety

Important safety notes

WARNING

Your attention must always be focused on the traffic conditions.

Only use COMAND Online or the telephone when the road and traffic conditions permit. Bear in mind that, at a speed of only 50 km/h, your vehicle covers a distance of nearly 14 m per second. The navigation system does not provide you with information about stop signs, give way signs, traffic regulations or road safety features. It is up to you to pay attention to these while driving the vehicle. Only enter a new destination when the vehicle is stationary.

Declarations of conformity

Wireless vehicle components

The following information applies to all components of the vehicle and the COMAND Online system which receive and/or transmit radio waves:

The components of this vehicle which receive and/or transmit radio waves are compliant with the basic requirements and other relevant provisions of Directive 1999/5/EC. You

can obtain further information from a Mercedes-Benz Service Centre.

Electromagnetic compatibility

The electromagnetic compatibility of the vehicle components has been tested and approved in accordance with Directive 72/245/EEC or the equivalent ECE-R 10 regulation, in their current respective valid version.

Correct use

Observe the following information when using COMAND Online:

- the safety notes in this manual
- traffic rules and regulations
- laws and safety standards pertaining to motor vehicles

i Improper work on electronic components or other systems (e.g. radio, DVD changer) and their software may result in malfunction or failure. Even systems that have not been modified could be affected because the electronic systems are connected. Electronic malfunctions can seriously jeopardise the operational safety of your vehicle.

i The functionality of a roof aerial (telephone, GPS) may be impaired if roof carrier systems are used.

Attaching metallised retrofit film to the windscreen may affect radio reception and have a negative impact on all other aerials (e.g. emergency aerial) in the vehicle interior.

i Only have work or changes to electronic components carried out at a qualified specialist workshop. This workshop should have the necessary specialist knowledge and tools to carry out the work required. Mercedes-Benz recommends that you use a Mercedes-Benz Service Centre. In particular, work relevant to safety or on safety-

related systems must be carried out at a qualified specialist workshop.

- i Protection against theft:** this device is equipped with technical provisions to protect it against theft. Further information on protection against theft can be obtained from a Mercedes-Benz Service Centre.

Qualified specialist workshop

Read the information on qualified specialist workshops in the vehicle Owner's Manual.

Copyright information

General notes

You can find information on licences for free and open-source software used in your vehicle and its electronic components on the following website: <http://www.mercedes-benz.com/opensource>.

Features of your COMAND Online

These operating instructions describe all standard and optional equipment available for your COMAND Online system at the time of purchase. Country-specific differences are possible. Please note that your COMAND Online system may not be equipped with all the features described. This is also the case for systems and functions relevant to safety. Therefore, the equipment on your COMAND Online system may differ from that in the descriptions and illustrations. Should you have any questions concerning equipment and operation, please consult a Mercedes-Benz Service Centre.

Function restrictions

For safety reasons, some COMAND functions are restricted or unavailable while the vehicle is in motion. You will notice this, for example because either you will not be able to select

certain menu items or COMAND Online will display a message to this effect.

At a glance

Features of your COMAND Online

This Supplement describes all the standard and optional equipment for your COMAND Online system, as available at the time of going to print. Country-specific differences are possible. Please note that your COMAND Online system may not be equipped with all the features described.

COMAND Online operating system

Overview



- ① COMAND display (▷ page 284)
- ② COMAND control panel with a single DVD drive or DVD changer
- ③ COMAND controller (▷ page 291)

You can use COMAND Online to operate the following main functions:

- the navigation system
- the audio function
- the telephone function
- the video function
- the system settings

- online and Internet functions
- the Digital Owner's Manual
(availability depending on vehicle model)

You can call up the main functions:

- using the corresponding function buttons
- using the main function bar in the COMAND display

COMAND display

General notes

! Do not use the space in front of the display for storage. Objects placed here could damage the display or impair its function. Avoid any direct contact with the display surface. Pressure on the display surface may result in impairments to the display, which could be irreversible.

Wearing polarised sunglasses may impair your ability to read the display.

The display has an automatic temperature-controlled switch-off feature. The brightness is automatically reduced if the temperature is too high. If necessary, the display may temporarily switch off completely.

Display overview



Example display for radio

- ① Status bar
- ② To call up the audio menu
- ③ Main function bar
- ④ Display/selection window
- ⑤ Radio menu bar

Status bar ① shows the time and the current settings for telephone operation.

If the traffic announcement function is switched on, the **TA** symbol appears and when the sound is switched off, the **⊗** symbol is displayed.

The main functions – navigation, audio, telephone and video – feature additional menus. This is indicated by triangle ②. The following table lists the available menu items.

Main function bar ③ allows you to call up the desired main function. When the main function is activated, it is identifiable by the white lettering.

In the example, the audio main function is set to radio mode and display/selection window ④ is active.

Radio menu bar ⑤ allows you to operate the radio functions.

Menu overview

Navi	Audio	Tele- phone	Video	System	Symbol 
Route settings	Radio (including DAB radio)	Telephone	TV	Calls up the system menu	Calls up the Digital Owner's Manual (availability depends on vehicle model)
Map settings	Disc	Address book	DVD video		Calls up COMAND Online and Internet
Personal POIs	Memory card		AUX		Calls up the Mercedes-Benz Mobile website
<input checked="" type="checkbox"/> Switches automatic reading aloud of traffic messages on/off	MUSIC REGISTER				
<input checked="" type="checkbox"/> Activates/deactivates road name announcement	USB memory				
<input checked="" type="checkbox"/> Audio fadeout on/off	Media Interface				
<input checked="" type="checkbox"/> Activates/deactivates the alternative routes function	Bluetooth® audio				
Avoids an area	AUX				
Shows the map version					

System menu overview

Settings	Time	Consumption	Seat	Display off
Display settings	Sets the time	Calls up the fuel consumption display	Changes the driver/front-passenger seat settings	Switches off the display
Sets the text reader speed	Sets the format			
LINGUATRONIC settings	Sets the time zone			
Sets the language				
Favourites button				
Reversing camera				
<input checked="" type="checkbox"/> Activates/deactivates Bluetooth®				
Importing/exporting data				
Resets COMAND Online				

If equipped with the reversing camera: when the function is activated and COMAND Online is switched on, the image from the reversing camera is automatically shown in the COMAND display when reverse gear is engaged.

Switching the COMAND display on/off

► Press the **[sys]** function button.

or

► Select **System** in the main function bar by sliding **↑** and turning **⌚** the COMAND controller and press **⌚** to confirm.

In both cases, the system menu appears.

► **To switch off:** select **Display off** and press **⌚** to confirm.

► **To switch on:** press one of the function buttons, e.g. **[sys]**, **[NAVI]** or the **[←]** back button.

Cleaning instructions

! Do not touch the COMAND display. The display has a very sensitive high-gloss surface; there is a risk of scratching. If you have to clean the screen, however, use a

mild cleaning agent and a soft, lint-free cloth.

The display must be switched off and have cooled down before you start cleaning. Clean the display screen, when necessary, with a commercially available microfibre cloth and cleaning agent for TFT/LCD displays. Do not apply pressure to the display surface when cleaning it, as this could cause irreversible damage. Then dry the surface with a dry microfibre cloth.

Avoid using alcoholic thinners, petrol or abrasive cleaning agents. These could damage the display surface.

COMAND control panel

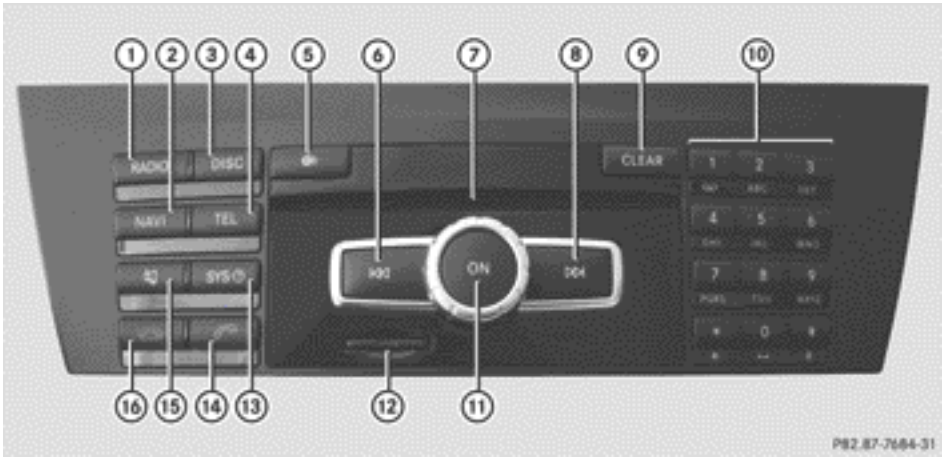

Function	Page
① Switches to radio mode Switches wavebands Switches to DAB radio mode	453 455 453
② Switches to navigation mode Shows the menu system	315 316
③ Pressing the [disc] function button repeatedly: <ul style="list-style-type: none"> • Switches to audio CD, audio DVD and MP3 mode or DVD video mode • Switches to memory card mode • Switches to MUSIC REGISTER • Switches to USB storage device mode • Switches to Media Interface or audio AUX mode • Switches to Bluetooth® audio mode 	463 463 475 463 486 483

Function	Page
④ Calls up the telephone basic menu: <ul style="list-style-type: none"> • Telephony via the Bluetooth® interface • Convenience telephony 	386 388
⑤ Load/eject button <ul style="list-style-type: none"> Single DVD drive DVD changer 	460 460
⑥ Selects a station using the station list (FM and DAB radio mode) Selects a station using the station search function Rewind Selects the previous track	455 456 467 466
⑦ Disc slot <ul style="list-style-type: none"> • Loads CDs/DVDs • Ejects CDs/DVDs • Updates the digital map 	460 461 374

	Function	Page
⑧	Selects a station using the station list (FM and DAB radio mode)	455
	Selects a station using the station search function	456
	Fast forward	467
	Selects the next track	466
⑨	Delete button	
	• Deletes characters	302
	• Deletes an entry	302
⑩	Number keypad	
	• Selects stations via the station presets	456
	• Stores stations manually	457
	• Mobile phone authorisation	383
	• PIN entry (convenience telephony)	387
	• Telephone number entry	391
	• Sends DTMF tones	393
	• Character entry	300
	• Selects a location for the weather forecast from the memory	435
	<input type="text" value="#"/> Displays the current track being played	469
	<input type="text" value="*"/> Selects stations by entering the frequency manually	457
	<input type="text" value="*"/> Selects a track	466

	Function	Page
⑪	Switches COMAND Online on/off	293
	Adjusts the volume	294
⑫	SD memory card slot	463
⑬	Calls up the system menu	303
⑭	PIN confirmation (convenience telephony)	387
	Accepts a call	391
	Dials a number	391
	Redial	392
	Accepts a waiting call	393
⑮	Mute	293
	Switches the hands-free microphone on/off	392
	Cancels the text message read-aloud function	404
	Switches off the traffic and navigation announcements	293
⑯	Rejects a call	391
	Ends an active call	394
	Rejects a waiting call	393

COMAND controller

Overview

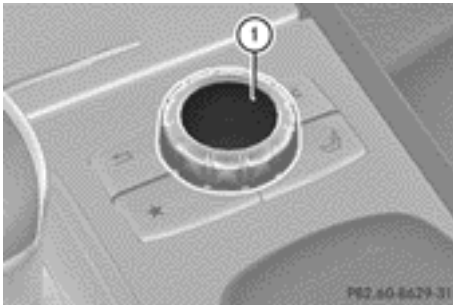

① COMAND controller

You can use the COMAND controller to select the menu items in the COMAND display.

You can:

- call up menus or lists
- scroll within menus or lists and
- exit menus or lists

Operation

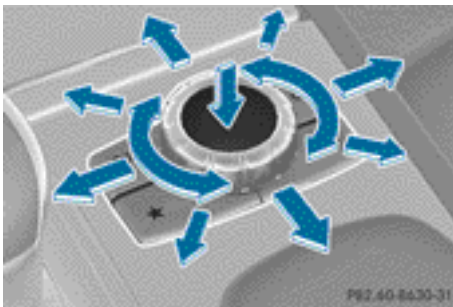

Example: operating the COMAND controller

The COMAND controller can be:

- pressed briefly or pressed and held
- turned clockwise or anti-clockwise
- slid left or right
- slid forwards or backwards
- slid diagonally

Example of operation

In the instructions, operating sequences are described as follows:

- ▶ Press the button.
Radio mode is activated.
 - ▶ Select **Radio** by sliding and turning the COMAND controller and press to confirm.
 - ▶ Confirm **Station list** by pressing .
- The station list appears.

Buttons on the COMAND controller

Overview

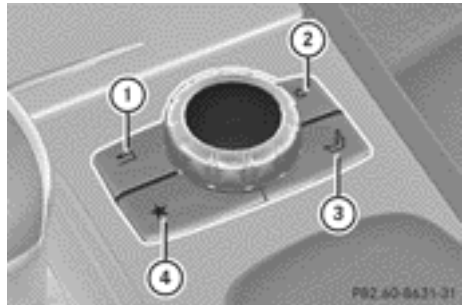

- ① Back button (▷ page 291)
- ② Delete button (▷ page 292)
- ③ Seat function button (▷ page 310)
- ④ Favourites button (▷ page 306)

i If your vehicle is not equipped with the seat function button, it will have two favourites buttons.

Back button

You can use the back button to exit a menu or to call up the basic display of the current operating mode.

- ▶ **To exit the menu:** briefly press the back button.
COMAND Online changes to the next higher menu level in the current operating mode.
- ▶ **To call up the basic display:** press and hold the back button.

To call up the basic display: press and hold the **BACK** back button. COMAND Online changes to the basic display of the current operating mode.

Delete button

- ▶ **To delete individual characters:** briefly press the **c** delete button.
- ▶ **To delete an entire entry:** press and hold the **c** delete button.

Seat function button









You can use button  to call up the following seat functions:

- multicontour seat (with 4-way lumbar support)
- active multicontour seat (dynamic seat and massage function)
- balance (seat heating distribution)

More information on the seat functions (▷ page 310).

Favourites button

You can assign predefined functions to the ***** favourites button and call them up by pressing the button (▷ page 306).

- ▶ **To switch on navigation mode:** press the **NAVI** function button.
- ▶ **To show the menu:** press  the COMAND controller.
- ▶ Select **Destination** by sliding  and turning  the COMAND controller and press  to confirm.
- ▶ Select **Address entry** and press  to confirm. The address entry menu appears.
- ▶ Slide  the COMAND controller and switch to main function bar .
- ▶ Select **System** in the main function bar by turning  the COMAND controller and press  to confirm. The system menu appears.



Operating COMAND Online

Selecting a main function



Address entry menu

 Main function bar

Situation: switching from navigation mode (address entry menu) to the system settings.

Selecting the menu of a main function

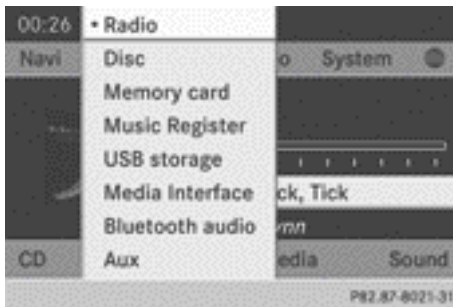

Example display for audio CD mode and audio menu (below)

① Calls up the audio menu

If one of the navigation, audio, telephone or video main functions is switched on, triangle ① appears next to the entry in the main function bar. You can now select an associated menu.

The example shows how to call up the audio menu from audio CD mode (an audio CD is playing).

- ▶ Select **Audio** in the main function bar by sliding $\uparrow \odot$ the COMAND controller and press \odot to confirm.
The Audio menu appears.
The • dot indicates the currently selected audio mode.
- ▶ Select another audio mode, e.g. **Radio**, by turning $\uparrow \odot$ the COMAND controller and press \odot to confirm.
Radio mode is activated.

Selecting a menu item



- ▶ Select the station by turning $\uparrow \odot$ the COMAND controller and press \odot to confirm.
The station is set.

Basic functions of COMAND Online

Switching COMAND Online on/off

- ▶ Press the \odot control knob.
A warning message appears.
COMAND Online calls up the previously selected menu.
- ❗ If you switch off COMAND Online, playback of the current audio or video source will also be switched off.

Mute

Audio/video source sound

- ▶ Press the \square button on the COMAND control panel or the multifunction steering wheel.
The sound from the respective audio or video source is switched on or muted.
- ❗ When the sound is off, the system displays the \times icon in the status line. When you change the audio or video source, or adjust the volume, sound automatically switches on again.
- ❗ Even if the sound is switched off, you will still hear traffic and navigation system announcements.

Switching traffic and navigation announcements off and on again

► To switch traffic announcements off:

press and hold the  button until the **TA** display disappears from the status bar of the display.

A confirmation tone sounds.

► To switch traffic announcements on again:

press and hold the  button until the **TA** display in the status bar appears.

A confirmation tone sounds.

► To switch navigation announcements off:

press and hold the  button during an announcement.

► To switch navigation announcements on again:

switch COMAND Online off and then on again (▷ page 293).

or

► Start a new route calculation (▷ page 321).

or

► To have the announcement repeated while the navigation menu is shown, select and press to confirm (▷ page 347).

Adjusting the volume

Adjusting the volume for the audio or video source

► Turn the control knob

or

► Press the or button on the multifunction steering wheel.

The volume of the currently selected audio or video source changes.

You can also adjust the volume for the following:

- traffic announcements
- navigation announcements
- phone calls
- LINGUATRONIC voice control (see the separate operating instructions)

Adjusting the volume for traffic announcements and navigation announcements

You can set the volume of traffic and navigation announcements relative to the volume of the audio or video source.

During traffic or navigation announcements:

► Turn the control knob

or

► Press the or button on the multifunction steering wheel.

Adjusting the volume for phone calls

You can adjust the volume for hands-free mode during a telephone call.

► Turn the control knob

or

► Press the or button on the multifunction steering wheel.

Adjusting the sound settings

Calling up the sound menu



You can make various sound settings for the different audio and video sources. This means that it is possible to set more bass for radio mode than for audio CD mode, for example. You can call up the respective sound menu from the menu of the desired mode.

The example describes how to call up the sound menu in radio mode.

- ▶ Press the **RADIO** function button.
The radio display appears. You will hear the last station played on the last waveband selected.
- ▶ Select **Sound** by sliding $\odot \downarrow$ and turning $\left\{ \odot \right\}$ the COMAND controller and press \odot to confirm.
You can now set the treble, bass and balance for radio mode.

Adjusting treble and bass

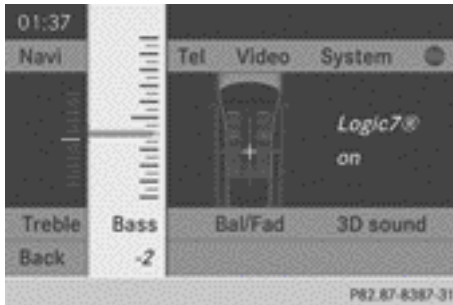

Adjusting the bass

- ▶ Select **Treble** or **Bass** in the sound menu by turning $\left\{ \odot \right\}$ the COMAND controller and press \odot to confirm.
An adjustment scale appears.
- ▶ Select a setting by turning $\left\{ \odot \right\}$ the COMAND controller and press \odot to confirm.
The setting is stored and you exit the menu.

Adjusting balance and fader



Adjusting the balance

The balance function is used to control whether the sound is louder on the driver's or on the front-passenger side.

The fader function is used to control whether the sound is louder in the front or in the rear of the vehicle.

You can adjust the fader depending on the vehicle model.

Equipped with Bang & Olufsen sound system: for the best sound focus, choose the setting **0**.

- ▶ Select **Bal/fad** (balance/fader) in the sound menu by turning $\left\{ \odot \right\}$ the COMAND controller and press \odot to confirm.
- ▶ Select a balance setting by sliding $\leftarrow \odot \rightarrow$ the COMAND controller and press \odot to confirm.

Surround sound

General notes

Your vehicle is equipped with one of two sound systems:

- harman/kardon[®]Logic 7[®] Surround Sound system
The harman/kardon[®]Logic 7[®] Surround Sound system allows you to set the optimum surround sound in the vehicle interior (▷ page 296).
- Bang & Olufsen sound system (▷ page 297)

Both sound systems are available for the following operating modes:

- radio (FM only)
- DAB radio
- audio CD
- audio DVD (MLP, dts, PCM and Dolby Digital audio formats)
- MP3 (including SD memory card and USB storage device)
- Media Interface
- Operation with Bluetooth[®] audio
- TV

- video DVD (PCM, dts and Dolby Digital audio formats)
- AUX

Because some DVDs contain both stereo and multichannel audio formats, it may be necessary to set the audio format (▷ page 505).

Discs which support the audio formats mentioned have the following logos:



harman/kardon®Logic 7® Surround Sound system

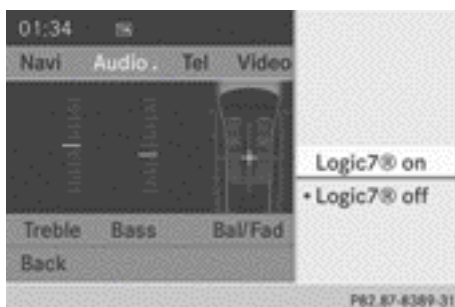

The example describes how to set the surround sound for radio mode.

- ▶ **To switch surround sound on/off:** press the **RADIO** function button.

The radio display appears. You will hear the last station played on the last waveband selected.

- ▶ Select **Sound** by sliding **⊙** and turning **⌂** the COMAND controller and press **⊙** to confirm.
- ▶ Select **surround** and press **⊙** to confirm.
- ▶ Select **Logic7® on** or **Logic7® off** by turning **⌂** the COMAND controller and press **⊙** to confirm.

Depending on your selection, surround sound is switched on or off and the menu is exited.

- ▶ **To exit the menu without saving:** press the **⏪** back button or slide **⊙** the COMAND controller.

i Please note the following: for the optimum audio experience for all passengers when Logic7® is switched on, the balance should be set to the centre of the vehicle interior.

You will achieve the best sound results by playing high-quality audio and video DVDs. MP3 tracks should have a bit rate of at least 128 kbit/s.

Surround-sound playback does not function for mono signal sources, such as the medium wave range (MW) in radio mode. If radio reception is poor, e.g. in a tunnel, you should switch off Logic 7®, as it may otherwise switch between stereo and mono and cause temporary sound distortions.

On some stereo recordings, the sound characteristics may differ from conventional stereo playback.

i The Logic7® on function creates a surround sound experience for every passenger when playing stereo recordings, for example. It enables optimum playback of music and films on CD, audio DVD or video DVD with multichannel audio formats, such as MLP, dts or Dolby Digital. This results in sound characteristics as the sound engineer intended when the original was recorded.

i If you select Logic7® off, all permissible formats are played as stored on the medium. Due to the design of the passenger compartment, an optimum audio experience cannot be guaranteed for all passengers.

Bang & Olufsen sound system

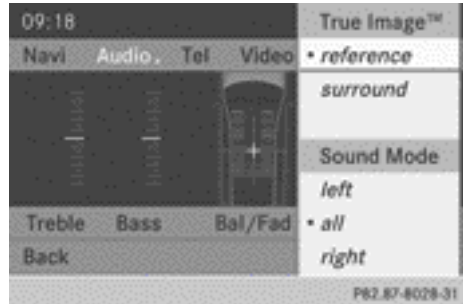

You can optimise the sound in the vehicle with the Bang & Olufsen sound system and the True Image™ sound technology. The Sound Mode function enables you to focus the selected sound setting within the vehicle.

The example describes how to set the optimum sound for radio mode.

Selecting the sound setting for True Image™

- ▶ Press the **RADIO** function button.
- ▶ Select **Sound** by sliding $\odot \downarrow$ and turning $\left[\odot \right]$ the COMAND controller and press \odot to confirm.
- ▶ Select **Bang&Olufsen** and press \odot to confirm.
 - A menu appears. A \bullet dot marks the current setting for True Image™.
- ▶ Select **reference** or **surround** and press \odot to confirm.
 - **reference**

This setting provides a crisp, clear, luxury high-end sound setting for a studio atmosphere in your vehicle.
 - **surround**

This setting enables a wide-ranging sound experience for playing music and videos.

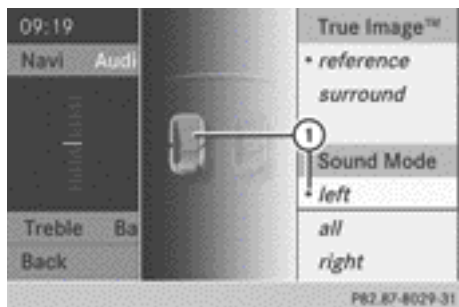

① Current position of the sound setting

For the optimum musical enjoyment, you can focus the sound image precisely on one seat. This means you are right at the centre of the listening experience, with all system parameters being precisely calculated for the selected position. The result is authentic music reproduction inside the vehicle.

Focusing the sound setting

- ▶ Press the **RADIO** function button.
- ▶ Select **Sound** by sliding $\odot \downarrow$ and turning $\left(\odot\right)$ the COMAND controller and press \odot to confirm.
- ▶ Select **Bang&Olufsen** and press \odot to confirm.
A menu appears. A \bullet dot marks the current setting for Sound Mode.
- ▶ Select **left**, **all** or **right** and press \odot to confirm.
- ▶ **To exit the menu:** press the \leftarrow back button or slide $\leftarrow \odot \rightarrow$ the COMAND controller.

i Please note the following: you will achieve the best sound results on your Bang & Olufsen sound system by playing high-quality audio DVDs and CDs.

MP3 tracks should have a bit rate of at least 224 kbit/s.

When playing using an iPod®, the bit rate should also be at least 224 kbit/s.

For optimum playback quality:

- ▶ Deactivate the “EQ” setting on the iPod®.

Surround-sound playback does not function for mono signal sources, such as the medium wave range in radio mode.

On some stereo recordings, the sound characteristics may differ from conventional stereo playback.

Character entry (telephony)

Example: entering characters



- ① **ABC** To switch the character bar to upper-case/lower-case letters
- ② **...** To switch the character bar from upper/lower-case letters to digits
- ③ **🌐** To change the language of the character bar
- ④ **c** To delete a character/entry

The example describes how to enter the surname "Schulz".

- ▶ Call up the input menu with data fields (▷ page 398).
- ▶ Select **S** and confirm by pressing \odot the COMAND controller.
S appears in the data field.
- ▶ Select **c** and confirm by pressing \odot the COMAND controller.
The letter **c** is added to **S** in the data field.
- ▶ Repeat the process until the name has been entered in full.

Other input menu functions:

- deleting a character/entry (▷ page 300)
 - switching between upper/lower-case letters (▷ page 299)
 - changing the character set (▷ page 299)
 - moving the cursor in the data field (▷ page 300)
- **To enter a phone number:** select the digits one by one in the corresponding data field by turning **⏪** and sliding **↑**/**↓** the COMAND controller and press **⏩** to confirm.

Switching data fields

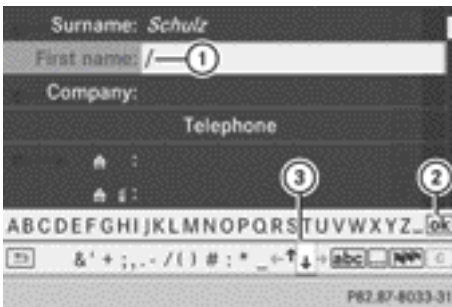

- ① Cursor in the next data field
- ② Stores an entry
- ③ **↑** and **↓** symbols to select a data field

In the input menu, if you want to enter a first name after you have entered a surname, for example, proceed as follows to switch between the data fields:

Option 1

- Select **↑** or **↓** in the character bar and press **⏩** to confirm.
The input menu shows the data field selected.

Option 2

- Slide **⏪** the COMAND controller repeatedly until the character bar disappears.
- Select the data field by sliding **↑**/**↓** and press **⏩** to confirm.

Storing an entry

- **After making an entry in the input menu, e.g. to create a new entry** (▷ page 398): select the **⏩** symbol in the character bar by turning **⏪** the COMAND controller and press **⏩** to confirm.
The entry is stored in the address book.

Further functions available in the character bar

Changing the language of the character bar



While making an entry in the input menu (▷ page 398):

- Select **⏩** and press **⏩** to confirm.
- Select the language by turning **⏪** the COMAND controller and press **⏩** to confirm.

Switching the character bar to letters

While making an entry in the input menu, e.g. to create a new entry (▷ page 398):

- Select the **ABC** (upper case) or **abc** (lower case) symbol and press **⏩** to confirm.

Changing the character set

While making an entry in the input menu (▷ page 398):

- ▶ Select the symbol and press to confirm.
 - **ABC** (upper/lower case)
 - **123** (digits)
 - **Other** (special characters such as @, €, etc.)

Moving the cursor to the next data field

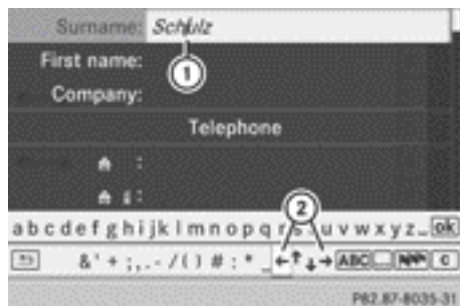

- ① Cursor (repositioned)
- ② and symbol to reposition the cursor

While making an entry in the input menu
(▷ page 398):

- ▶ Select the or symbol and press to confirm.

Deleting a character/entry

While making an entry in the input menu
(▷ page 398):

- ▶ **To delete characters:** press the button on the control panel.

or

- ▶ Select the symbol by sliding and turning the COMAND controller and press to confirm.

or

- ▶ Press the button next to the COMAND controller.

- ▶ **To delete an entry:** press and hold the button on the control panel until the entire entry has been deleted.

or

- ▶ Select the symbol and press and hold the COMAND controller until the entire entry has been deleted.

or

- ▶ Press and hold the button next to the COMAND controller until the entire entry is deleted.

Character entry (navigation)

General information

The following paragraphs describe how to enter characters using town input for **BER-LIN** as an example.

If you want to use the address entry menu to enter a town, a street or a house number, for example, COMAND Online offers you:

- a list with a character bar (option 1)
- a selection list (option 2)

You can enter the characters using either the character bar or the number keypad. In the selection list, you select an entry to copy it to the address entry menu.

Option 1: list of towns/streets with character bar



Town list with character bar

- ▶ Call up the town list with character bar
(▷ page 318).
The alphabetically sorted town list shows the first available entries.



- ① Character entered by the user **B**
- ② Characters automatically added by COMAND Online **AABE**
- ③ List entry that most closely resembles the current entry by the user
- ④ To switch to the selection list
- ⑤ To delete an entry
- ⑥ To change the character set (Latin/Cyrillic)
- ⑦ Characters not currently available
- ⑧ Characters currently available
- ⑨ Character bar
- ⑩ To cancel an entry
- ⑪ Currently selected character
- ⑫ List

Entering characters using the character bar

- ▶ Select **B** by turning the COMAND controller and press to confirm.

List ⑫ shows all available town names beginning with a **B**. List entry most closely resembling current entry by user ③ is always highlighted at the top of the list (**BAABE** in the example).

All characters currently entered by the user are shown in black (letter **B** ① in the example). Letters added by COMAND Online are shown in grey ② (letters **AABE** in the example).

Character bar ⑨ shows the letters still available for selection in black ⑧. These can be selected. In the example, the letter **A** is highlighted ⑪. Which characters

remain available depends on the characters already entered by the user and on the data stored in the digital map. Characters that are no longer available are shown in grey ⑦.



- ▶ Select **E, R, L, I, N** in succession, confirming each by pressing .



Entering characters using the number keypad

- ▶ To enter the letter **B**: press the number key twice in quick succession. The character appears at the bottom of the display when the key is pressed. The first available letter is highlighted.

You see which characters you can enter with that key. Each time the key is pressed, the next character is selected.

Example: key :

- press once = A
- press twice = B
- press three times = C

- ▶ Wait until the character display goes out. The entries matching your input are shown in the list.
- ▶ Enter **E, R, L, I, N** using the corresponding keys.

Further functions in the list with character bar

- ▶ **To delete characters:** press the **CLEAR** button on the control panel.

or

- ▶ Press the **c** button next to the COMAND controller.

or

- ▶ Select the **c** symbol in the character bar by sliding **⬇** and turning **⌚** the COMAND controller and press **⏹** to confirm.

- ▶ **To delete an entry:** press **CLEAR** on the control panel.

or

- ▶ Press and hold the **c** button next to the COMAND controller until the entire entry is deleted.

or

- ▶ Select the **c** symbol in the character bar and press and hold **⏹** the COMAND controller until the entire entry has been deleted.

- ▶ **To switch the character set:** select **⌨** and press **⏹** to confirm. This will switch the character set from Latin to Cyrillic and back.

- ▶ **To cancel an entry:** select the **⏪** symbol in the bottom left of the character bar and press **⏹** to confirm.

or

- ▶ Press the **⏪** back button. The address entry menu appears.

- ▶ **To accept the first list entry:** press and hold **⏹** the COMAND controller until the address entry menu appears. The accepted list entry is shown there.

Calling up the list as a selection list

You can switch from the list of towns with the character bar to the list of towns as a selection list at any point during character entry.

- ▶ Slide **⬆** the COMAND controller repeatedly until the town list appears as a selection list.

Select the desired town from the selection list.

or

- ▶ Select **ok** in the character bar by turning **⌚** the COMAND controller and press **⏹** to confirm.

If there are several entries for a town or if several towns of the same name are stored, then **ok** is highlighted in the character bar.

- ▶ Press **⏹** the COMAND controller.

Option 2: town list as selection list



COMAND Online either shows the selection list automatically or you can call up the selection list from the list with the character bar.

The example shows the selection list after the town **BERLIN** has been entered. The entry is highlighted automatically.

- ▶ Confirm **BERLIN** by pressing  the COMAND controller.
You see the available entries.



- ▶ Confirm **BERLIN (1XXXX)** by pressing  the COMAND controller.
The address entry menu appears.

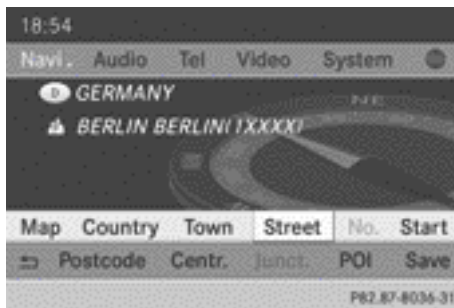

Observe the information on destination entry (▷ page 317).

System settings

Features of your COMAND Online





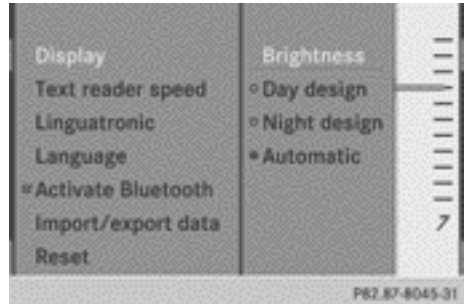

This Supplement describes all the standard and optional equipment for your COMAND Online system, as available at the time of going to print. Country-specific differences are possible. Please note that your COMAND Online system may not be equipped with all the features described.

Display settings

Setting the brightness





The brightness detected by the display light sensor affects the setting options for this function.



- ▶ Press the **sys** button.
- ▶ Select **Settings** by turning  the COMAND controller and press  to confirm.
- ▶ Select **Display** and press  to confirm.
- ▶ Select **Brightness** and press  to confirm.
- ▶ Adjust the brightness by turning  the COMAND controller and press  to confirm.

Display design

Your COMAND Online display features optimised designs for operation during daytime and night-time hours. You can customise the design by manually selecting day or night design, or opt for an automatic setting.

- ▶ Press the **sys** button.
- ▶ Select **Settings** by turning  the COMAND controller and press  to confirm.
- ▶ Select **Display** and press  to confirm.
- ▶ Select **Day design**, **Night design** or **Automatic** by turning  the COMAND controller and press  to confirm.
A dot indicates the current setting.

Design	Explanation
Day design	The display is set permanently to day design.
Night design	The display is set permanently to night design.
Automatic	If the Automatic setting is selected, COMAND Online evaluates the readings from the automatic vehicle light sensor and automatically switches between the display designs.

Time settings

General information

If COMAND Online is equipped with a navigation system and has GPS reception, COMAND Online automatically sets the time and date. You can also adjust the time yourself in 30-minute increments, but the date cannot be changed.

i If you set the time in 30-minute increments, any time zone settings and settings for changing between summer and standard time are lost. Switching between summer and standard time (▷ page 305).

i The following navigation system functions require the time, time zone and summer/standard time to be set correctly in order to work properly:

- route guidance on routes with time-dependent traffic guidance
- calculation of expected time of arrival

i With this function, you can set the time for every display in the vehicle.

Setting the time



- ▶ Press **sys**.
- ▶ Select **Time** by turning **⏸** the COMAND controller and press **⏵** to confirm.
- ▶ Select **Set time** and press **⏵** to confirm.
- ▶ Set the time by turning **⏸** the COMAND controller and press **⏵** to confirm. The time is accepted.

Setting the time/date format

- ▶ Press **sys**.
- ▶ Select **Time** by turning **⏸** the COMAND controller and press **⏵** to confirm.
- ▶ Select **Format** and press **⏵** to confirm. The **•** symbols show the current settings.
- ▶ Set the format by turning **⏸** the COMAND controller and press **⏵** to confirm.

Abbreviation	Meaning
DD / MM / YY	Day/Month/Year (date format)
HH/MM	Hours/Minutes (time format)

You can set the 24-hour or the AM/PM format.

Adjusting the time zone and switching to summer time

- ▶ Press **sys**.
- ▶ Select **Time** by turning **⏪** the COMAND controller and press **⏩** to confirm.
- ▶ Select **Time zone** and press **⏩** to confirm. The country list appears. The **•** dot indicates the current setting.
- ▶ Select the country you are currently in by turning **⏪** the COMAND controller and press **⏩** to confirm. A time zone list may also be displayed, depending on the country selected.
- ▶ Select the time zone and press **⏩** to confirm.

Further steps depend on whether the navigation system currently has GPS reception and on which country you have selected.

You have the following two options:

- ▶ **To switch manually:** select **Summer time** or **Standard time** and press **⏩** to confirm.
- ▶ **To switch automatic changeover on/off:** select **Autom. Summer / Winter time on** or **Autom. Summer / Winter time off** by turning **⏪** the COMAND controller and press **⏩** to confirm. The **•** dot indicates the current setting.

i If you have switched off the automatic changeover function, you must change from summer to standard time and vice versa manually using the "Set time" function (> page 304).

Text reader settings

- ▶ Press the **sys** button.
- ▶ Select **Settings** by turning **⏪** the COMAND controller and press **⏩** to confirm.

- ▶ Select **Text reader speed** and press **⏩** to confirm. A list appears. The **•** dot indicates the current setting.
- ▶ Select a setting by turning **⏪** the COMAND controller and press **⏩** to confirm.

LINGUATRONIC settings

Opening/closing the help window

The help window provides information in addition to the audible instructions during individualisation and during the subsequent voice control.

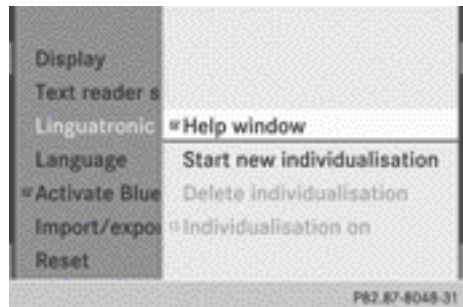

- ▶ Press the **sys** button.
- ▶ Select **Settings** by turning **⏪** the COMAND controller and press **⏩** to confirm.
- ▶ Select **Linguatronic** and press **⏩** to confirm.
- ▶ Select **Help window** and press **⏩** to confirm. You have switched the help window on or off .

Individualisation

Using individualisation, you can fine-tune LINGUATRONIC to your own voice and thus improve voice recognition. See the separate operating instructions.

Bluetooth® settings

General information about Bluetooth®

Bluetooth® technology is the standard for short-range wireless data transmission of up to approximately 10 metres. Bluetooth® allows, for example, the exchange of vCards.



Bluetooth® is a registered trademark of Bluetooth Special Interest Group (SIG) Inc.

Activating/deactivating Bluetooth®

- ▶ Press **sys**.
The system menu appears.
- ▶ Select **Settings** by turning **⏻** the COMAND controller and press **⏻** to confirm.
- ▶ Select **Activate Bluetooth** and press **⏻** to confirm.
This switches Bluetooth® on or off .

Setting the system language

This function allows you to determine the language for the menu displays and the navigation announcements. The selected language affects the characters available for entry.

The navigation announcements are not available in all languages. If a language is not available, the navigation announcements will be in English.

If you change the system language, the language for LINGUATRONIC will be also be changed. If the selected language is not supported by LINGUATRONIC, English will be selected.

- ▶ Press the **sys** button.

- ▶ Select **Settings** by turning **⏻** the COMAND controller and press **⏻** to confirm.
- ▶ Select **Language** and press **⏻** to confirm.
The list of languages appears. The **•** dot indicates the current setting.
- ▶ Select the language by turning **⏻** the COMAND controller and press **⏻** to confirm.
COMAND loads the selected language and sets it.

i If you are using Arabic map data, the text information can also be shown in Arabic on the navigation map. To do this, select **English (Arabic map)** as the language from the list of languages. Navigation announcements are then made in Arabic.

Assigning a favourites button

- ▶ **To assign a favourites button:** press the **sys** button.
- ▶ Select **Settings** by sliding **⏻** and turning **⏻** the COMAND controller and press **⏻** to confirm.
- ▶ Select **Assign as favourite** and press **⏻** to confirm.
The list of predefined functions appears.
The dot **•** indicates the currently selected function.
- ▶ Select the function by turning **⏻** the COMAND controller and press **⏻** to confirm.
The favourites button is assigned the selected function.
- ▶ **Example: to call up a favourite:** press the **★** favourites button.
This calls up the predefined function.

You can select the following predefined functions in a menu:

- **Display off/on:** you can switch the display off or on.
- **Full screen: 'Clock':** you can call up the full screen with clock.
- **Menu:** you can call up the COMAND Online and Internet functions.
- **Full screen: 'Map':** you can call up the full screen with map.
- **Spoken driving tip:** you can call up the current driving recommendation.
- **Display traffic messages:** you can call up traffic reports.
- **Navigate to 'Home address':** you can start route guidance to your home address if you have already entered and saved the address (▷ page 321).
- **Detour menu:** you can call up the Detour menu and then avoid a section of the route and recalculate the route (▷ page 348).
- **Compass screen:** you can call up the compass.
- **Driver's seat massage, Front-passenger's seat massage or Massage: both front seats:** you can start the massage function, depending on which seats are selected (▷ page 313).

Importing/exporting data

! When data is being copied to the USB stick or the memory card, the stick or the card must not be removed under any circumstances. Doing so runs the risk of data loss.

Use this function to:

- transfer your personal COMAND data from one system/vehicle to another
- make a backup copy of your personal data (export data) and load it again (import data)

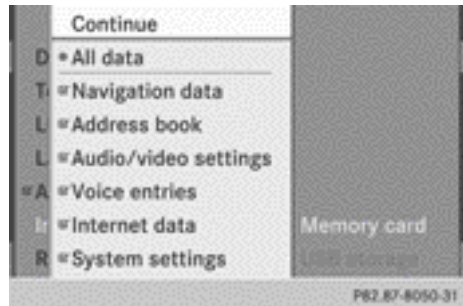
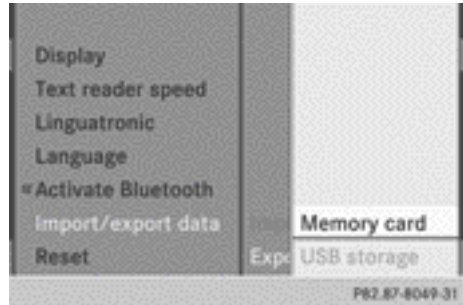

You can either use an SD memory card or a USB storage device (e.g. a USB stick) as temporary storage.



- ▶ Insert the SD memory card (▷ page 463).
- or
- ▶ Connect a USB device (e.g. a USB memory stick) (▷ page 463).
- ▶ Press the **[sys]** button.
The system menu appears.
- ▶ Select **Settings** by turning **⏪** the COMAND controller and press **⏩** to confirm.
- ▶ Select **Import/export data** and press **⏩** to confirm.
- ▶ Select **Import data** or **Export data** and press **⏩** to confirm.
- ▶ **To select a preset:** select **Memory card** or **USB storage** and press **⏩** to confirm.

- ▶ Select **All data** and press  to confirm. This function exports all the data to the selected disc.

or





- ▶ Select the data type and press  to confirm. Depending on the previous entry, select the data type for the export or not .
- ▶ Select **Continue** and press  to confirm.

- i** Personal music files in the MUSIC REGISTER cannot be saved and imported again using this function.

Reset function

You can completely reset COMAND Online to the factory settings. Amongst other things, this will delete all personal COMAND data. This includes the station presets, entries in the destination memory and in the list of previous destinations in the navigation system and address book entries. Resetting is recommended before handing over or selling the vehicle, for example.

Data on the internal hard drive, e.g. music files in the MUSIC REGISTER, will be deleted. You can also delete music files from the MUSIC REGISTER using the "Delete all music files" function (> page 477).

- ▶ Press the **sys** function button.
- ▶ Select **Settings** by turning  the COMAND controller and press  to confirm.
- ▶ Select **Reset** and press  to confirm. A prompt appears asking whether you wish to reset.
- ▶ Select **Yes** or **No** and press  to confirm. If you select **No**, the process will be cancelled.

If you select **Yes**, a prompt will appear again asking whether you really wish to reset.

- ▶ Select **Yes** or **No** and press  to confirm. If you select **Yes**, a message will be shown. COMAND Online is reset and restarted. If you select **No**, the process will be cancelled.

Vehicle functions

Features of your COMAND Online

This Supplement describes all the standard and optional equipment for your COMAND Online system, as available at the time of going to print. Country-specific differences are possible. Please note that your COMAND Online system may not be equipped with all the features described.

Climate control status display

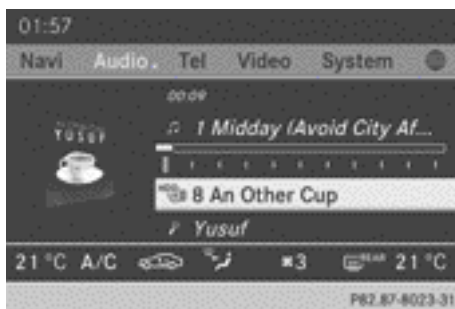











Example: the climate control status display in the COMAND display

If you change the settings of the climate control system, the climate status display appears for three seconds at the bottom of the screen in the COMAND display. You will see the current settings of the various climate control functions.

Overview of climate control systems, see separate vehicle operating instructions.

The climate control status display appears when:

- ▶ You turn the temperature control and set the temperature
- or
- ▶ You turn the control to set the airflow.
- or
- ▶ You press one of the following buttons:

-  Increases air flow
-  Decreases air flow
-  Switches climate control on/off
-  Switches the ZONE function on/off
-  Controls the air conditioning automatically
-  Sets the climate control style in automatic mode (FOCUS/MEDIUM/DIFFUSE)
-  Sets the air distribution
-  ,  or  Sets the air distribution
-  Turns on the defrost function

i How to call up the climate control status display depends on the climate control system of your vehicle.

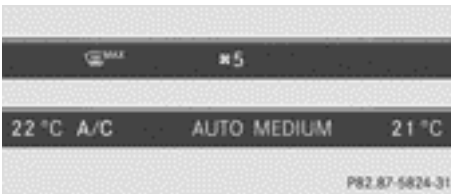

Example settings for the defrost function (top) and for the climate mode in automatic mode

- ▶ **To hide the display:** turn or press the COMAND controller.
- or
- ▶ Press one of the buttons on COMAND Online.

Fuel consumption indicator





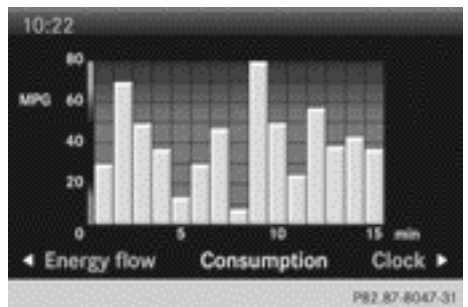

Overview

Depending on the vehicle equipment and the engine variant installed, fuel consumption can be shown in the COMAND display.

If your vehicle is a hybrid vehicle and the installed engine variant supports it, you can call up other displays (see the separate operating instructions).

Calling up/exiting the display



- ▶ **To call up the full-screen display:** press the  button.
- ▶ In the system menu, slide  the COMAND controller up until the **Full screen** option is selected.
- ▶ Press  the COMAND controller. The system display is shown in full-screen mode (without the system menu).
- ▶ Slide   the COMAND controller repeatedly until the fuel consumption indicator appears. The COMAND display shows the fuel consumption for the last 15 minutes of the journey.
- ▶ **To exit the full-screen display:** press  the COMAND controller. The system menu appears.

Every bar of the graph displays the average value for one minute.

The fuel consumption display may differ from the display in the **FROM START** trip computer



in the **Trip** menu; see the separate vehicle Owner's Manual.

Driving conditions menu (Active Body Control)

General notes

On vehicles with Active Body Control (ABC), you can display some driving systems and additional information in the COMAND display.

Calling up drive status regulator (ABC)

- ▶ Press **sys** .
- ▶ In the system menu, slide **↑**  the COMAND controller up until the display/selection window is selected.
- ▶ Slide **←**  **→** the COMAND controller repeatedly until the drive status regulator (ABC) appears.
The corresponding displays appear in the COMAND display.

Details on the displays:

- for vehicles except AMG vehicles; see the separate vehicle operating instructions
- for AMG vehicles; see the separate vehicle operating manual.

Exiting the display

- ▶ Slide **←**  **→** the COMAND controller until the desired display (clock or fuel consumption) is shown.

Seat functions

Overview

The possible settings depend on the type of seat and the vehicle series. Using the  button next to the COMAND controller or the seat menu item in the system menu, you can call up the following seat setting functions:

- on M-Class and GL-Class vehicles with multicontour seat:
 - seat cushion length
 - backrest side bolsters
 - lumbar
 - massage
- on SL-Class vehicles with lumbar seat:
 - lumbar
 - balance
- on SL-Class vehicles with multicontour seat:
 - seat cushion side bolsters
 - backrest side bolsters
 - lumbar
 - balance
- on SL-Class vehicles with dynamic multicontour seat:
 - seat cushion side bolsters
 - backrest side bolsters
 - lumbar
 - driving dynamics
 - massage
 - balance

i You can also store and recall the current seat function settings using the memory button and the corresponding memory position switch; see the separate vehicle Owner's Manual.

The massage function cannot be started or stopped using the memory button.

Selecting the seat



First select the seat which you wish to adjust.

- ▶ Press the or **sys** button.
- ▶ Select **Seat** and press to confirm.
- ▶ To switch to the lower line, for both options slide the COMAND controller.
- ▶ Select **Driver's seat** or **Front-pass. seat** by turning the COMAND controller and press to confirm.

Adjustment functions

Adjusting the seat cushion length

This function is available on M-Class and GL-Class vehicles with multicontour seats.

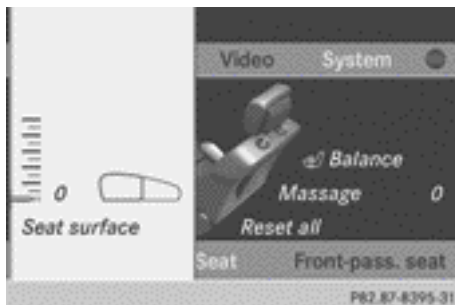

This function allows you to adjust the height of the seat cushion.

- ▶ Select the seat (▷ page 311).
 - ▶ Select **Seat cushion** by turning the COMAND controller and press to confirm.
- A scale appears.

- ▶ Turn or slide the COMAND controller and press to confirm.
- ▶ **To exit the menu:** press the back button.

Adjusting the seat contour in the lumbar region of the seat backrest

This function is available on M-Class and GL-Class vehicles with multicontour seats and on all SL-Class vehicles, regardless of seat variants.



This function allows you to adjust the air cushions in the lumbar region of the backrest (4-way lumbar support).

- ▶ Select the seat (▷ page 311).
 - ▶ Select **Lumbar** by turning the COMAND controller and press to confirm.
- A crosshair appears. You can make two settings:
- **Vertical:** to move the point of greatest lumbar support up or down
 - **Horizontal:** to adjust the amount of support
- ▶ Slide or the COMAND controller and press to confirm.
 - ▶ **To exit the menu:** press the back button.

Adjusting the sides of the seat backrest (backrest side bolsters)

This function is available on M-Class, GL-Class and SL-Class vehicles with multicontour seats or dynamic multicontour seats.

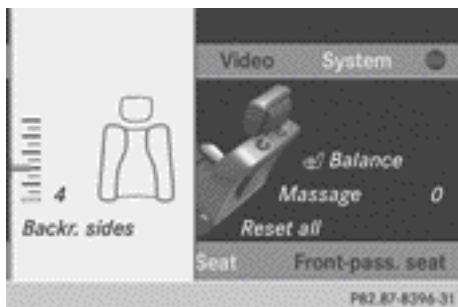

- ▶ Select the seat (▷ page 311).
- ▶ Select **Backr. sides** by turning $\left[\odot \right]$ the COMAND controller and press $\left[\odot \right]$ to confirm. A scale appears.
- ▶ Turn $\left[\odot \right]$ or slide $\uparrow \odot \downarrow$ the COMAND controller and press $\left[\odot \right]$ to confirm.
- ▶ **To exit the menu:** press the $\left[\leftarrow \right]$ back button.

i For SL-Class vehicles with dynamic multicontour seat: if driving dynamics is activated and in the process of reacting to a change of direction (e.g. cornering), the backrest side bolsters cannot be adjusted.

Adjusting the seat side bolsters

This function is only available on SL-Class vehicles with multicontour seats or dynamic multicontour seats.

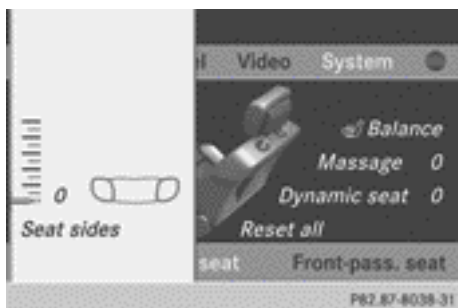

This function allows you to adjust the air cushions in the seat side bolsters.

- ▶ Select the seat (▷ page 311).
- ▶ Select **Seat sides** by turning $\left[\odot \right]$ the COMAND controller and press $\left[\odot \right]$ to confirm. A scale appears.
- ▶ Turn $\left[\odot \right]$ or slide $\uparrow \odot \downarrow$ the COMAND controller and press $\left[\odot \right]$ to confirm.
- ▶ **To exit the menu:** press the $\left[\leftarrow \right]$ back button.

Balance

This function is available on SL-Class vehicles.

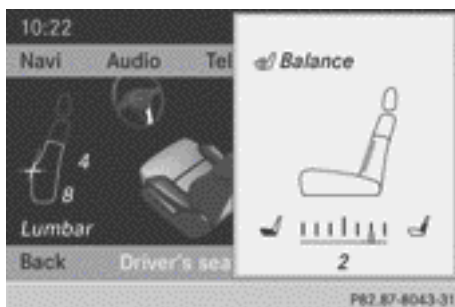





The Balance function controls the distribution of heat on the seat backrest and cushion.

The Balance function influences the currently set heating level of the seat heating; see the separate vehicle Owner's Manual.

- ▶ Select the seat (▷ page 311).
- ▶ Select **Balance** by turning $\left[\odot \right]$ the COMAND controller and press $\left[\odot \right]$ to confirm.

A scale appears and shows the current setting. Positive values indicate the heat output for the seat backrest, negative values indicate the heat output for the seat cushion. The intensity is indicated by an orange bar in the stylised seat above the scale.

The values stand for:



- **0** - backrest and seat cushion are heated equally to the maximum level
 - **1 to 3** - the heat output to the seat cushion is reduced in one-third increments
 - **-1 to -3** - the heat output to the backrest is reduced in one-third increments
- ▶ Turn  or slide  the COMAND controller and press  to confirm.
- ▶ **To exit the menu:** press the  back button.

Massage function

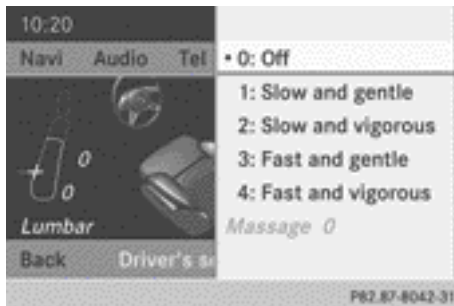
This function is available on M-Class and GL-Class vehicles with multicontour seats and on SL-Class vehicles with dynamic multicontour seats.





Example display (M-Class or GL-Class)

- ▶ Select the seat (▷ page 311).
- ▶ Select **Massage** by turning  the COMAND controller and press  to confirm.

A list appears.

You can select different types of massage function:

- **0: Off**
- **1: Slow and gentle**
- **2: Slow and vigorous**
- **3: Fast and gentle**
- **4: Fast and vigorous**

- ▶ Turn  or slide  the COMAND controller and press  to confirm.



The massage function runs for approximately 15 to 25 minutes, depending on the setting.

- ▶ **To exit the menu:** press the  back button.

Adjusting the driving dynamics

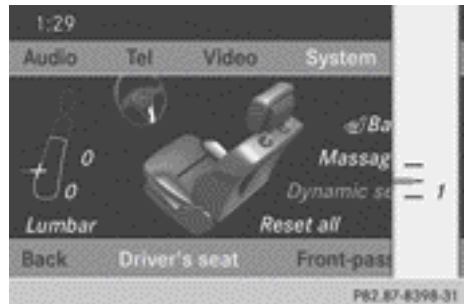
This function is only available on SL-Class vehicles with dynamic multicontour seats.







- ▶ Select the seat (▷ page 311).
- ▶ Select **Dynamic seat** by turning  the COMAND controller and press  to confirm.

A scale appears.

You can select:

- **0:** Off
- **1:** level 1 (medium setting)
- **2:** level 2 (high setting)

- ▶ Turn  or slide  the COMAND controller and press  to confirm.

- ▶ **To exit the menu:** press the  back button.

Resetting all adjustments



- ▶ Select the seat (▷ page 311).
- ▶ Select **Reset all** by turning **⏸** the COMAND controller and press **⏹** to confirm. A query appears.
- ▶ Select **Yes** or **No** and press **⏹** to confirm. If you select **No**, the process will be aborted. After you select **Yes**, all seat adjustments are reset to the default values (factory setting).

Reversing camera

WARNING

The reversing camera is only an aid and may show a distorted view of obstacles, show them incorrectly or not at all.

The image from the reversing camera is shown in the COMAND display when reverse gear is engaged if:

- your vehicle is equipped with a reversing camera
- COMAND Online is switched on
- the **Activation by R gear** function is activated.

If the function is activated, the COMAND display will automatically switch back to the previously selected display as soon as you shift out of reverse gear.

i For further information on the reversing camera, see separate vehicle Owner's Manual.

- ▶ Press the **sys** function button. The system menu appears.
- ▶ Select **Settings** by turning **⏸** the COMAND controller and press **⏹** to confirm.
- ▶ Select **Rear view camera** and press **⏹** to confirm.
- ▶ Select **Activation by R gear** and press **⏹** to confirm. The function is switched on or off , depending on the previous status.

Navigation

Features of your COMAND Online

This Supplement describes all the standard and optional equipment for your COMAND Online system, as available at the time of going to print. Country-specific differences are possible. Please note that your COMAND Online system may not be equipped with all the features described.

Introduction

Important safety notes

WARNING

For safety reasons, only enter a new destination when the vehicle is stationary. You may otherwise be distracted from the traffic conditions, cause an accident and injure yourself and others.

COMAND Online calculates the route to the destination without taking account of the following, for example:

- traffic lights
- stop and give way signs
- parking or stopping restrictions

- road narrowing
 - other road and traffic rules and regulations
- COMAND Online may give incorrect driving recommendations if the data on the digital map does not correspond to actual conditions. For example, a route may have been diverted or the direction of a one-way street may have changed.

For this reason, you must always observe road and traffic rules and regulations during your journey. Road and traffic rules and regulations always have priority over the system's driving recommendations.

General notes

Operational readiness of the navigation system

In vehicles for certain countries, the navigation system is not operational immediately after delivery. The digital map is not pre-installed.

If this is the case, the following message appears in the display after you switch to navigation mode:

Please insert the map DVD to activate navigation.

► **To install the digital map:** (► page 374).

The navigation system must determine the position of the vehicle before first use or whenever operational status is restored. Therefore, you may have to drive for a while before precise route guidance is possible.

GPS reception

Correct functioning of the navigation system depends, amongst other things, on GPS reception. In certain situations, GPS reception may be impaired, there may be interference or there may be no reception at all, e.g. in tunnels or multi-storey car parks.

i The functionality of a roof aerial (telephone, GPS) may be impaired if roof carriers are used.

Entry restriction

On vehicles for certain countries, there is a restriction on entering data.

The restriction is active above a vehicle speed of about 5 km/h. The restriction is deactivated as soon as the vehicle speed drops below about 3 km/h.

When the restriction is active, certain entries cannot be made. This will be indicated by the fact that certain menu items are greyed out and cannot be selected.

The following entries are not possible, for example:

- entering the destination town and street
- entering a destination via the map
- entering POIs in the vicinity of a town or via a name search
- editing entries
- direct entry using the number keypad

Other entries are possible, however, such as entering POIs in the vicinity of the destination or current position.

Switching to navigation mode



Map showing the menu; route guidance inactive

- ① Status bar
- ② Main function bar
- ③ Current vehicle position
- ④ Navigation system menu bar

► Press the **NAVI** function button.

The map is displayed with the menu either shown or hidden.

or

- ▶ Select **Navi** in the main function bar by sliding $\uparrow \odot$ and turning $\left[\odot \right]$ the COMAND controller and press \odot to confirm. The map is displayed with the menu shown.

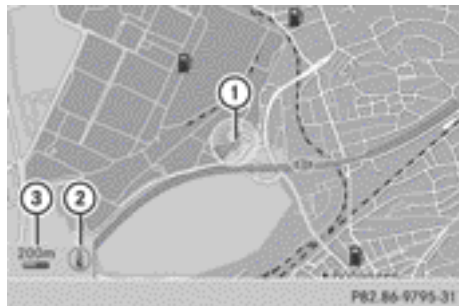

Map without the menu; route guidance inactive

- ① Current vehicle position
- ② Map orientation selected
- ③ Map scale selected

i **Route guidance active** means that you have entered a destination and that COMAND has calculated the route. The display shows the route, changes of direction and lane recommendations. Navigation announcements guide you to your destination.

Route guidance inactive means that no destination has been entered and no route has been calculated yet.

Showing/hiding the menu

You can show or hide the menu at the lower edge of the map.

- ▶ **To hide the menu:** slide $\uparrow \odot$ the COMAND controller and, when the **Full screen** menu item is shown, press \odot to confirm.

or

- ▶ Press the $\left[\leftarrow \right]$ back button. The map can be seen in full-screen mode.
- ▶ **To show the menu:** press \odot the COMAND controller when the map is shown in full-screen mode.

Basic settings

Setting route type and route options

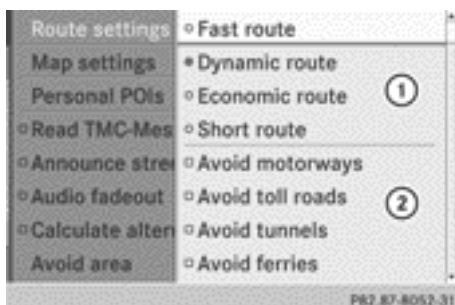

Route settings menu (start of menu)

- ① To select the route type
- ② To set route options

- ▶ Select **Navi** in the main function bar by sliding $\uparrow \odot$ and turning $\left[\odot \right]$ the COMAND controller and press \odot to confirm.
- ▶ Select **Route settings** and press \odot to confirm. The route settings menu appears.
- ▶ Select a route type and press \odot to confirm. A filled circle indicates the current setting.
- ▶ Select the route option(s) and press \odot to confirm. The route options are switched on or off , depending on the previous status.

i If you change the route type and/or the route options while route guidance is active, COMAND Online will calculate a new route.

If you change the route type and/or the route options while route guidance is inactive, COMAND Online uses the new setting for the next route guidance.

Route guidance active: a destination has been entered and the route has been calculated.

Route guidance inactive: no destination has been entered yet and no route has been calculated yet.

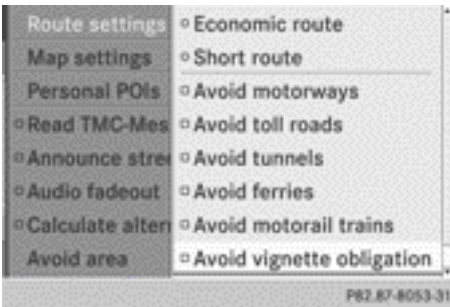

Route settings (end of menu)

You can select the following route types:

- **Fast route:** COMAND Online calculates a route with the shortest (minimised) journey time.
- **Dynamic route:** same route type as **Fast route**. In addition, COMAND Online takes into account any RDS-TMC traffic reports it receives during route guidance. The navigation system can help you avoid a traffic jam, for example. If a faster route is determined due to a received RDS-TMC traffic announcement, the navigation system changes the route. If possible, it will bypass blocked roads.
- **Eco route:** the **Eco route** is a variant of the **Fast route** route type. COMAND Online will attempt to minimise the journey distance at the expense of a slightly increased journey time.
- **Short route:** COMAND Online calculates a route with the shortest possible (minimised) route distance.

i RDS-TMC is not available in all countries.

i The route calculated may, for example, include ferry connections, even if the **Avoid ferries** route option is switched on.

In some cases, COMAND Online may not be able to take all the selected route options into account, e.g. when calculating particularly long routes.

i **To avoid toll roads:** route calculation is performed without taking into considera-

tion sections (e.g. tunnels, stretches of motorway, inner cities) for which you must pay a fee (toll).

To avoid routes requiring a special toll sticker: route calculation is performed without taking into consideration route networks (e.g. a country's motorway network) for which a toll (vignette) is due. A vignette allows temporary use of the route network. Example time limits are 10 days, 2 months or 1 year.

► **To exit the menu:** slide ←⊙→ the COMAND controller.

Entering a destination

Important safety notes

WARNING

For safety reasons, only enter a new destination when the vehicle is stationary. You could otherwise be distracted from the traffic conditions, cause an accident and injure yourself and others.

Entering a destination by address

Introduction

Options for destination entry:

- enter the country, town/postcode, street and house number
- enter the country, town/postcode and street
- enter the country, town/postcode and centre
- enter the country, town/postcode, street and junction
- enter the country and town

Country and town are sufficient to start navigating. You can enter either a town or a postcode. By entering further address data such as the street and house number, you can specify the destination more precisely.

- i** You can only enter a street, house number, junction or centre once you have entered a country and a town or postcode.
- i** You can only enter those towns, streets, postcodes etc. that are stored in the digital map. This means that for some countries, you cannot enter postcodes, for example.

This step-by-step example of how to enter an address uses the following example data:

Germany

Berlin

Unstrutstraße 1

You can of course enter any country, town, street and house number desired and enter, for example, your home address (My address).

Calling up the address entry menu



Address entry menu

Calling up the address entry menu

- ▶ Select **Navi** in the main function bar by sliding **↑** and turning **⌂** the COMAND controller and press **⏹** to confirm.
- ▶ Select **Destination** in the lower menu bar by turning **⌂** the COMAND controller and press **⏹** to confirm.
- ▶ Select **Address entry** and press **⏹** to confirm.
The address entry menu appears. If you have previously entered a destination, this will be shown in the display.

Depending on the sequence in which you enter the address and on the data status of

the digital map, some menu items may not be available at all or may not yet be available.

Example: after country selection the **Street**, **No.**, **Centr.** (centre), **Junct.** (junction), **POI**, **Save** and **Start** menu items are not yet available. The **Postcode** menu item will not be available unless the digital map contains postcodes.

Entering the country, city, street, house number



Country list with character bar

Entering a country

- ▶ Call up the address entry menu (▷ page 318).
- ▶ Select **Country** in the address entry menu by turning **⌂** and sliding **↑** the COMAND controller and press **⏹** to confirm.
You see the country list with character bar. Entering characters using town input as an example (▷ page 300).



Country list as selection list

- ▶ To switch to the country list as a selection list: select **ok** in the character bar by turning **⏏** the COMAND controller and press **⏏** to confirm.

or

- ▶ Slide **⏏** the COMAND controller once or twice.
- ▶ Select **GERMANY** by turning **⏏** the COMAND controller and press **⏏** to confirm. The address entry menu appears again. **GERMANY** has now been entered.

Entering a town

- ▶ Call up the address entry menu (▷ page 318).
- ▶ Select **Town** in the address entry menu by turning **⏏** and sliding **⏏** the COMAND controller and press **⏏** to confirm. You will see the town list either with the character bar (option 1) or as a selection list (option 2).



Town list with character bar

Option 1: town list with character bar

- ▶ Enter **BERLIN**. Entering characters using town input as an example (▷ page 300).

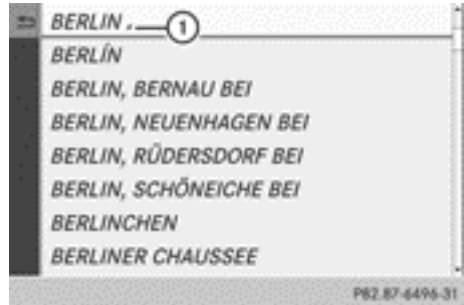

List of towns as selection list

Option 2: town list as selection list

- ▶ Select **BERLIN** by turning **⏏** the COMAND controller and press **⏏** to confirm. Entries with the **▲** ① symbol cannot be uniquely assigned. Another selection list is shown.



- ▶ Select **BERLIN(1XXXX)** by turning **⏏** the COMAND controller and press **⏏** to confirm. The address entry menu appears again. **BERLIN(1XXXX)** has now been entered.

Entering a street

- ▶ Call up the address entry menu (▷ page 318).
- ▶ Select **Street** in the address entry menu by turning **⏏** and sliding **⏏** the COMAND controller and press **⏏** to confirm. You will see the street list either with characters (option 1) or as a selection list (option 2).



Street list with character bar

Option 1: street list with character bar

- ▶ Enter **UNSTRUTSTRASSE**. Entering characters using town input as an example (▷ page 300).



Street list as selection list

Option 2: street list as selection list

- ▶ Select **UNSTRUTSTRASSE** by turning **⏪** the COMAND controller and press **⏩** to confirm.
- ▶ Irrespective of the option, press **⏩** to confirm your selection. The address entry menu appears again. **UNSTRUTSTRASSE** has now been entered.

Entering a house number

- ▶ Call up the address entry menu (▷ page 318).
- ▶ Select **No.** in the address entry menu by turning **⏪** and sliding **↑** and **↓** the

COMAND controller and press **⏩** to confirm.

You will see the house number list either with the character bar (option 1) or as a selection list (option 2).



House number list with character bar

Option 1: house number list with character bar

- ▶ Enter **1**. Entering characters using town input as an example (▷ page 300).



House number list as selection list

Option 2: house number list as selection list

- ▶ Select **1** by turning **⏪** the COMAND controller and press **⏩** to confirm.
- ▶ Irrespective of the option, press **⏩** to confirm your selection. The address entry menu appears again. **1** has now been entered.

Starting route calculation



Address entry menu with destination address

- ① Destination address
- ② To start route calculation

COMAND Online can now calculate or save the route to the entered destination address.

- ▶ Call up the address entry menu (▷ page 318).
- ▶ In the address entry menu, confirm **Start** by pressing

If no other route has been calculated, route calculation starts immediately (option 1). If another route has already been calculated (route guidance is active), a prompt appears (option 2).

Option 1 – no route guidance active: route calculation starts. While route calculation is in progress, an arrow will indicate the direction to your destination. Below this, you will see a message, e.g. **Calculating fast route....**

Once the route has been calculated, route guidance begins. If the vehicle is travelling on a non-digitised road, the system displays the linear distance to the destination, the direction of the destination and the **Off road** message. In this case, the display will be greyed out.

Option 2 – route guidance is already active: if route guidance is already active, a prompt will appear asking whether you wish to terminate the currently active route guidance.

- ▶ Select **Yes** or **No** and press to confirm. If you select **Yes**, COMAND Online will stop route guidance and start route calculation for the new destination.

If you select **No**, COMAND Online will continue with the active route guidance.

- ❗ Route calculation takes a certain amount of time. The time depends on the distance from the destination, for example. COMAND Online calculates the route using the digital map data.

The calculated route may differ from the ideal route, e.g. due to roadworks or incomplete map data. Please also refer to the notes about the digital map (▷ page 374).

Entering and storing your home address

You can either enter your home address for the first time (option 1) or edit a previously stored home address (option 2).

- ▶ **Option 1:** enter the address, e.g. a town, street and house number (▷ page 317).
- ▶ Call up the address entry menu (▷ page 318).
- ▶ Select **Save** in the address entry menu by turning and sliding the COMAND controller and press to confirm.
- ▶ Select **Save as "My Address"** and press to confirm. COMAND Online stores your home address as **My address** in the destination memory.
- ▶ **Option 2:** proceed as described under "Option 1". A prompt appears asking whether the current home address should be overwritten.
- ▶ Select **Yes** and press to confirm. After selecting **Yes**, the **Data saved.** message appears.

Entering a postcode, centre and junction Searching by postcode

Entering a postcode will delete a previously entered town.

- ▶ Call up the address entry menu (▷ page 318).
- ▶ Select **Postcode** in the address entry menu by turning **↻** and sliding **↑**/**↓** the COMAND controller and press **⊞** to confirm. You will see the postcode list either with the character bar (option 1) or as a selection list (option 2).



List of postcodes with character bar
Option 1: postcode list with character bar

- ▶ Enter a postcode. Entering characters using town input as an example (▷ page 300).

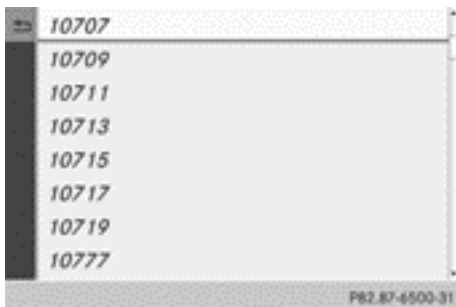

Postcode list as selection list
Option 2: postcode list as selection list

- ▶ Select the desired postcode by turning **↻** the COMAND controller.
- ▶ Irrespective of the option, press **⊞** to confirm your selection. If COMAND Online can assign the postcode to one town unambiguously (e.g. 74172 for NECKARSULM), the address entry menu

appears again. You can now complete the address, e.g. by entering a street.

If COMAND Online cannot assign the post-code unambiguously to a specific address, the address entry menu also appears again. The postcode is automatically entered. You can now enter the street for a more precise location. Only streets in the area covered by the entered postcode are available.

- ▶ Start route calculation (▷ page 321).

Entering a town centre

Entering a centre will, for example, delete a previously entered street.

- ▶ Call up the address entry menu (▷ page 318).
- ▶ Select **Centr.** (centre) in the address entry menu by turning **↻** and sliding **↑**/**↓** the COMAND controller and press **⊞** to confirm. You will see the centre list either with the character bar (option 1) or as a selection list (option 2).



Town centre list with character bar
Option 1: centre list with character bar

- ▶ Enter a centre. Entering characters using town input as an example (▷ page 300).

- i** In big cities, you can also enter the centres of districts.



Centre list as selection list

Option 2: centre list as a selection list

- ▶ Select a centre by turning **[⏪]** the COMAND controller.

For options 1 and 2:

- ▶ Confirm your selection by pressing **[⏩]**. The address entry menu appears again. The centre selected has been entered.
- ▶ Start route calculation (▷ page 321).

Entering a junction

Entering a junction will delete a previously entered house number.

- ▶ Call up the address entry menu (▷ page 318).
- ▶ Select **Junct.** (junction) in the address entry menu by turning **[⏪]** and sliding **↑** the COMAND controller and press **[⏩]** to confirm.

You will see the junction list either with the character bar (option 1) or as a selection list (option 2).



Junction list with character bar

Option 1: junction list with character bar

- ▶ Enter a junction. Entering characters using town input as an example (▷ page 300).

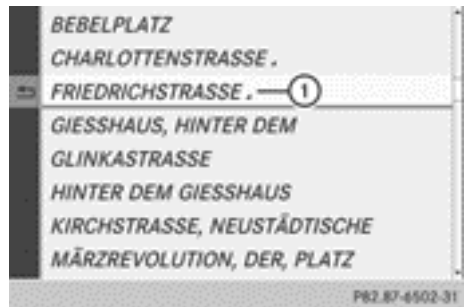

Junction list as selection list

Option 2: junction list as selection list

- ▶ Select a junction by turning **[⏪]** the COMAND controller and press **[⏩]** to confirm. Entries with the **[⏪]** symbol cannot be uniquely assigned. Another selection list is shown.
- ▶ Select an entry by turning **[⏪]** the COMAND controller and press **[⏩]** to confirm. The address entry menu appears again. The junction selected has been entered.
- ▶ Start route calculation (▷ page 321).

Selecting a destination from the destination memory

An entry named "My address" can always be found at the top of the destination memory. You may wish to assign your home address to this entry, for example, and select it for route guidance. Further information on entering a home address (▷ page 321).

- ▶ **To switch on navigation mode:** press the **[NAVI]** function button.
- ▶ **To show the menu:** press **[⏩]** the COMAND controller.

- ▶ Select **Destination** in the navigation system menu bar by turning **⏻** the COMAND controller and press **⏻** to confirm.
- ▶ Select **From memory** and press **⏻** to confirm.
You will see the destination memory list either with the character bar (option 1) or as a selection list (option 2).



Destination memory list with character bar

Option 1: destination memory list with character bar

- ▶ Enter a destination, e.g. "My address".
Enter characters (> page 300).



Destination memory list as selection list

Option 2: destination memory list as a selection list

- ▶ Select **My address** by turning **⏻** the COMAND controller.

- ▶ Irrespective of the option, press **⏻** to confirm your selection.
The address entry menu appears again. "My address" has been entered.



- ① Starting route calculation

- ▶ **To start route calculation:** select **Start** and press **⏻** to confirm.

Entering a destination from the list of last destinations

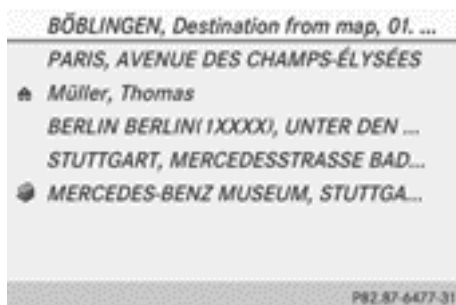

Previous destinations

- ▶ **To switch on navigation mode:** press the **NAVI** function button.
- ▶ **To show the menu:** press **⏻** the COMAND controller.
- ▶ Select **Destination** in the navigation system menu bar by turning **⏻** the COMAND controller and press **⏻** to confirm.
- ▶ Select **From last destinations** and press **⏻** to confirm.

- ▶ Select the desired destination by turning **Ⓜ** the COMAND controller and press **Ⓜ** to confirm.
The address entry menu appears again. The destination address selected has been entered.

- ▶ **To start route calculation:** select **Start** and press **Ⓜ** to confirm.
Once the route has been calculated, route guidance begins (▷ page 321).

i Further information on the "Last destinations" memory (▷ page 362).

Entering a destination using the map

Calling up the map

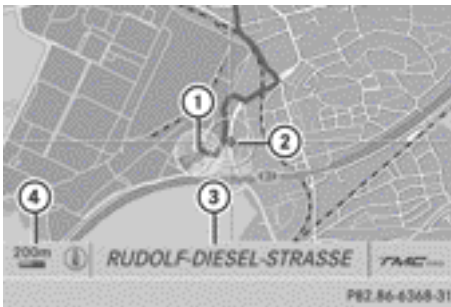

Map with crosshair

- ① Current vehicle position
 - ② Crosshair
 - ③ Details of the crosshair position
 - ④ Map scale selected
- ▶ **To switch on navigation mode:** press the **NAVI** function button.
 - ▶ **To show the menu:** press **Ⓜ** the COMAND controller.
 - ▶ Select **Destination** in the navigation system menu bar by turning **Ⓜ** the COMAND controller and press **Ⓜ** to confirm.
 - ▶ Select **Using map** and press **Ⓜ** to confirm.
The map with crosshair is shown.

Display **③** depends on the settings selected in "Map information in the display" (▷ page 366). If the digital map contains the necessary data, the current road is shown. If the geo-coordinates display is switched on, the geo-coordinates of the crosshair are shown.

Moving the map and selecting the destination

- ▶ Call up the destination entry via the map (▷ page 325).
- ▶ **To scroll the map:** slide **←→**, **↑↓** or **↻** the COMAND controller.
- ▶ **To set the map scale:** as soon as you turn **Ⓜ** the COMAND controller, the scale bar appears.
- ▶ Turn **Ⓜ** until the desired scale is set.
Turning clockwise zooms out from the map; turning anti-clockwise zooms in.
- ▶ **To select a destination:** press **Ⓜ** the COMAND controller.
If the crosshair lies outside the digital map, COMAND Online uses the nearest digitised road for route calculation. The **The crosshair is outside the digitalised area of the map.** message is shown. If the crosshair is located over a body of water, you will see the message: **The destination is located in a body of water. Please select another destination.**

- ▶ Select **OK** and press **Ⓜ** to confirm.
If the destination is within the limits of the digital map, COMAND Online attempts to assign the destination to the map.
If the destination can be assigned, you will see the address entry menu with the address of the destination. If not, you will see the **Destination from map** entry.
- ▶ **To start route calculation:** select **Start** and press **Ⓜ** to confirm.

Entering a destination using geo-coordinates

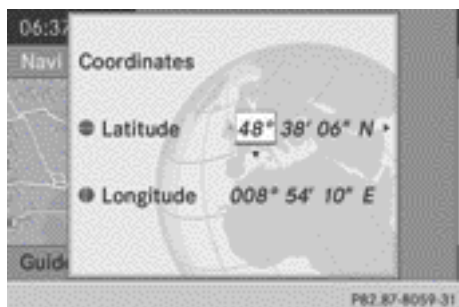

Geo-coordinates input menu

- ▶ **To switch on navigation mode:** press the **NAVI** function button.
- ▶ **To show the menu:** press **☺** the COMAND controller.
- ▶ Select **Destination** in the navigation system menu bar by turning **⏪** the COMAND controller and press **☺** to confirm.
- ▶ Select **Using geo-coordinates** and press **☺** to confirm.
The geo-coordinates input menu is shown.

You can now enter the latitude and longitude coordinates.

- ▶ **To change a value:** turn **⏪** the COMAND controller.
- ▶ **To move the selection within the line:** slide **←** the COMAND controller.
- ▶ **To move the selection between lines:** slide **↑** the COMAND controller.
- ▶ **To confirm the value:** press **☺** the COMAND controller.

i If the selected position is outside the digital map, COMAND Online uses the nearest digitised road for route calculation. You will see the **The co-ordinates are outside the map** message. If the selected position is located over a body of water, you will see the **The destination is located in a body of water. Please**

select another destination. message.

Entering an intermediate stop

Introduction

You can use this function to enter an intermediate stop along the route while the vehicle is in motion. COMAND Online provides a selection of predefined destinations in eight categories for this purpose, e.g. **FILLING STATION** or **COFFEE SHOP**.

When you have entered your intermediate stop, COMAND Online automatically recalculates the route to the main destination.

Destination search by category

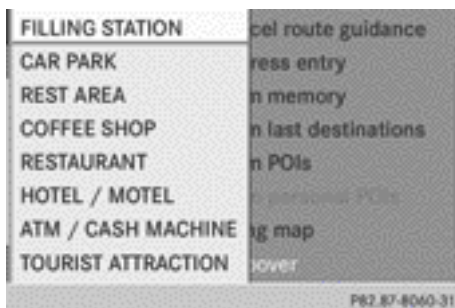

Intermediate stop categories

Option 1: the route does not have an intermediate stop.

- ▶ **To switch on navigation mode:** press the **NAVI** function button.
- ▶ **To show the menu:** press **☺** the COMAND controller.
- ▶ Select **Destination** in the navigation system menu bar by turning **⏪** the COMAND controller and press **☺** to confirm.
- ▶ Select **Stopover** and press **☺** to confirm.
The list of categories appears.

- ▶ **To select a category:** select a category by turning the COMAND controller and press to confirm.

COMAND Online first searches in the selected category for destinations along the route. If there are no destinations available there, COMAND Online searches for destinations within a radius of up to 100 km of the vehicle position.

If COMAND Online finds destinations, a list appears to the right of the display; see option 2.

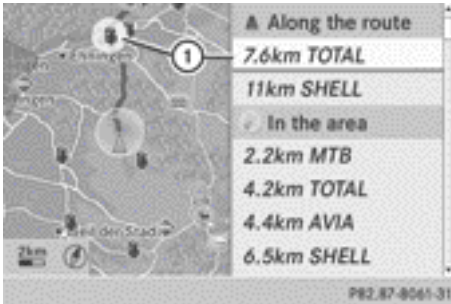

Example: search result for the selected category FILLING STATION

- ① Highlighted intermediate stop, current distance from the vehicle position and name of the intermediate stop

Option 2: the route already has an intermediate stop.

- ▶ Select **Change stopover** and press to confirm.
- ▶ Select a category; see option 1.

The intermediate stops along the route are displayed at the top of the list, sorted by increasing distance from the vehicle's current position. Below this, you will see the intermediate stops that COMAND Online finds in the vicinity of the vehicle's current position.

- ❗ For intermediate stops that are not located along the calculated route, the linear distance is shown.

- ▶ Select an intermediate stop by turning the COMAND controller and press to confirm.

The address entry menu appears, showing the destination address.

- ▶ **To start route calculation:** select **Start** and press to confirm.

If COMAND Online does not find any destinations, you will see a message to this effect.

- ▶ Confirm **OK** by pressing .
- ▶ Select a different category.

Deleting an intermediate stop

If an intermediate stop has already been entered, you can delete it.

- ▶ **To switch on navigation mode:** press the **NAVI** function button.

- ▶ **To show the menu:** press the COMAND controller.

- ▶ Select **Destination** in the navigation system menu bar by turning the COMAND controller and press to confirm.

- ▶ Select **Stopover** and press to confirm.

- ▶ Select **Delete stopover** and press to confirm.
COMAND Online deletes the intermediate stop and recalculates the route to the main destination.

Entering waypoints

Introduction

You can map the route yourself by entering up to two waypoints. The sequence of the waypoints can be changed at any time.

- ❗ An intermediate stop is always between the current position of the vehicle and the first waypoint.

Creating waypoints



Waypoint menu (with destination, without waypoint)

- ▶ **To switch on navigation mode:** press the **NAVI** function button.
- ▶ **To show the menu:** press the COMAND controller.
- ▶ Select **Destination** in the navigation system menu bar by turning the COMAND controller and press to confirm.
- ▶ Select **Way points** and press to confirm. The destination is entered in the menu.
- ▶ Confirm the symbol for waypoint 1 with the COMAND controller .









- ▶ Confirm **Set** with the COMAND controller .
- ▶ Enter the waypoint using one of the following options.

Selection	Step
Address entry	▶ Enter a destination by address (▷ page 317).
From memory	▶ Select a destination from the destination memory (▷ page 323).
From last destinations	▶ Select a destination from the list of last destinations (▷ page 324).
From POIs	▶ Select a POI (▷ page 330).
From personal POIs	▶ Enter a destination from the personal POIs (▷ page 338).
Using map	▶ Enter a destination using the map (▷ page 325).
Using geo-coordinates	▶ Enter a destination using the geo-coordinates (▷ page 326).



When the entry is complete, the waypoint appears.

- ▶ **To accept the waypoint:** confirm **OK** by pressing .
- ▶ **To display the details:** select **Details** by turning  the COMAND controller and press  to confirm.
- ▶ **To make a call:** select **Call** with the COMAND controller and press  to confirm. COMAND Online switches to telephone mode (▶ page 391).
- i** This menu item is available if the waypoint has a telephone number and a mobile phone is connected to COMAND Online (▶ page 381).
- ▶ **To call up the map:** select **Map** with the COMAND controller and press  to confirm.
- ▶ You can move the map and select the destination.
- ▶ **To store the waypoint in the destination memory:** select **Presets** with the COMAND controller and press  to confirm.











Waypoint menu with two waypoints

When you have accepted the waypoint, it is entered in the waypoint menu. The example shows the menu with two entered waypoints.

Editing waypoints





Way point menu

- ▶ **To change waypoints:** select the symbol for waypoint 1 or 2 in the waypoint menu by turning  the COMAND controller and press  to confirm.
- ▶ Select **Edit** and press .
- ▶ Use one of the destination entry options offered.
- ▶ **To change the sequence of the waypoints:** select **Swap** in the waypoint menu by turning  the COMAND controller and press  to confirm. The entries are swapped.
- i** To change the sequence, both waypoints must be entered.
- ▶ **To delete waypoints:** select the symbol for waypoint 1 or 2 in the waypoint menu by turning  the COMAND controller and press .
- ▶ Select **Delete** and press .
- i** The menu item is available after a waypoint has been entered.

Accepting waypoints for the route





In the example, there is an intermediate stop  and a waypoint.

- ▶ Select **Start** in the waypoint menu by turning  the COMAND controller and press  to confirm.

The route is calculated with the entered waypoints.

- i** If **Calculate alternative routes** is activated in the navigation menu (option 2), **Start** is displayed instead of the **Continue** menu item (▷ page 349).

- ▶ **To show the menu:** press  the COMAND controller.

- ▶ Select **Destination** in the navigation system menu bar by turning  the COMAND controller and press  to confirm.

- ▶ Select **From POIs** and press  to confirm. A menu appears.

- ▶ Choose one of the options and press  to confirm.

Further steps are arranged in a table according to the option selected (▷ page 331).

Entering a POI

Calling up the POI menu

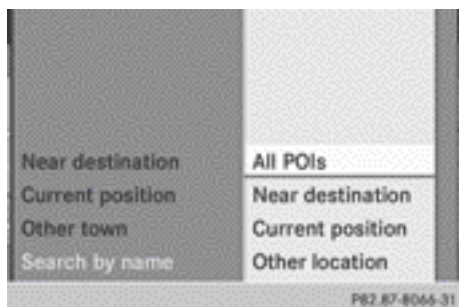





Example: POI menu

POIs are predefined destinations within categories, e.g. a filling station in the **AUTOMOTIVE** category.

- ▶ **To switch on navigation mode:** press the  function button.

Defining the position for the POI search

Selection	Characteristic	Instructions
Near destination	Entry is only possible when route guidance is active.	<ul style="list-style-type: none"> ▶ Select Near destination from the POI menu and press  to confirm. ▶ Select a POI category (▷ page 332).
Current position	The system looks for a POI in the vicinity of the current vehicle position.	<ul style="list-style-type: none"> ▶ Select Current position in the POI menu and press  to confirm. ▶ Select a POI category (▷ page 332).
Other town	After entering a town, the system looks for the POI within the town.	<p>Option 1</p> <ul style="list-style-type: none"> ▶ Select Other town in the POI menu and press  to confirm. ▶ Select the country, if desired (▷ page 318). ▶ Enter the town. Proceed as described in the "Entering a town" section (▷ page 318). ▶ Select a POI category (▷ page 332). <p>Option 2</p> <ul style="list-style-type: none"> ▶ Enter a town in the address entry menu (▷ page 318). ▶ Select POI and press  to confirm. ▶ Select a POI category (▷ page 318).
Search by name	You can call up all the POIs in the digital map or focus your search on the three previously selected positions.	<ul style="list-style-type: none"> ▶ Select Search by name in the POI menu and press  to confirm. ▶ Select All POIs or one of the three previously selected positions. The POI list with character bar appears. ▶ Proceed as described in the "POI list with character bar" section (▷ page 333).

Search by POI category



POI category list

- ▶ Call up the POI menu (▷ page 330)
After entering a town, the POI category list appears after choosing the menu item [Near destination](#), [Current position](#) or [Other town](#).
- ▶ Select a POI category by turning the COMAND controller and press to confirm. The arrow behind an entry shows that other categories are available.

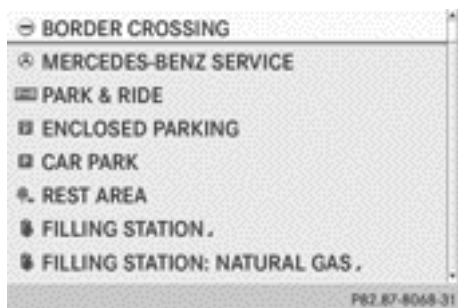

FILLING STATION category selected

- ▶ Select an entry and press to confirm.
The search for POIs begins in the vicinity of the selected position.

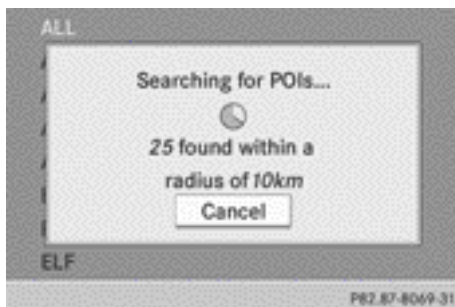

Example: POI search near the current position

The example shows a search after selection of the [FILLING STATION](#) entry.

- i** The POI search is cancelled when 50 POIs have been found.

COMAND Online searches within a radius of approximately 100 km.

Once the search is completed, the POI list is displayed.

If COMAND Online does not find any POIs within this radius, it extends its search range to approximately 200 km.

If COMAND Online finds one POI within this radius, it finishes the search.

POI list

Introduction



Example: POI list

The POI list displays the search results for the category in the vicinity of the selected position.

The search results display the following information:

- an arrow that shows the linear direction to the POI
- the linear distance to the POI
- the name of the POI

i The arrow and linear distance to the destination are not visible if you have entered a POI after entering another town.

The arrow is also not shown when searching for a POI in the vicinity of the destination.

Depending on the POI selected, COMAND Online uses different reference points in determining the linear distance to the destination:

- vicinity of current position: the linear distance is the distance from the current vehicle position to the POI.
- vicinity of destination: the linear distance is the distance of the POI from the destination entered.

Selecting a POI

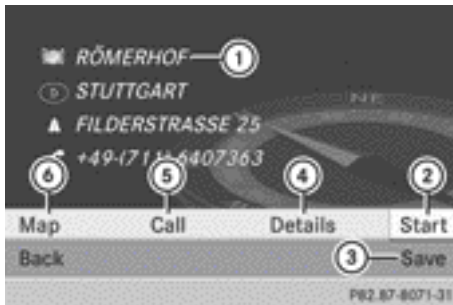

- ① POI with address
- ② To start route calculation
- ③ To store an address in the destination memory
- ④ To display details
- ⑤ To make a call (when available)
- ⑥ To display a POI's position on the map

The example has been selected in the **BAR & RESTAURANT** POI category. Further infor-

mation on searching via POI categories (▷ page 332).

► Select the POI in the POI list by turning **⏪** the COMAND controller and press **⏩** to confirm.

The full address of the POI selected appears.

► **To start route calculation:** select **Start** (2) and press **⏩** to confirm.

► **To store an address in the destination memory:** select **Save** (3) and press **⏩** to confirm. You can now select storing options (▷ page 361).

► **To show the detailed view:** select **Details** (4) and press **⏩** to confirm.

► **To make a call:** select **Call** (5) and press **⏩** to confirm. COMAND Online switches to telephone mode (▷ page 391).

i This menu item is available if the POI has a telephone number and a mobile phone is connected to COMAND Online (▷ page 381).

► **To call up the map:** select **Map** (6) and press **⏩** to confirm.

► You can move the map and select the destination (▷ page 325).

POI list with character bar



Example: search by name in the vicinity of the destination

If you have selected **Search by name** in the POI menu and then defined the position for the search, the POI list with character bar appears (▷ page 331).

Depending on your selection, you can select all available POIs on the digital map or the POIs in the vicinity of the selected position.





- ▶ Proceed as described in "Searching for a phone book entry" (▷ page 396).
If COMAND Online can assign the characters entered to one entry unambiguously, the address entry appears automatically.
- ▶ **To start route calculation:** select **Start** and press  to confirm.

Selecting a POI using the map











POI on the map

You can select POIs that are available in the selected (visible) section of the map. The POI is highlighted on the map, you will see further information on the upper edge of the display.

- ▶ **To switch on navigation mode:** press the  function button.
- ▶ **To show the menu:** press  the COMAND controller.
- ▶ Select **Guide** in the navigation system menu bar by turning  the COMAND controller and press  to confirm.
If POIs are available:
Depending on the map scale selected, POI icons appear on the map. The scale at which the icons are displayed on the map varies according to the icon. You can select the icons that you want COMAND Online to display.

If there are POIs, you will see a message to this effect.

-  You also see this message if you have selected the **No symbols** menu item under "Map display" (▷ page 365).
- ▶ **To confirm the message:** press  the COMAND controller.
- ▶ **To select a POI:** select **Next** or **Previous** and press  to confirm.
- ▶ **To show details for the selection:** select **Details** and press  to confirm.
- ▶ **To change to the map:** slide  the COMAND controller.
You can move the map and select the map section.
- ▶ **To start route calculation:** select **Start** and press  to confirm.
A prompt appears asking whether the POI should be used as the destination.
- ▶ Select **Yes** or **No** and press  to confirm.
If you select **Yes**, route guidance starts.
If you select **No**, you can choose a new POI.
-  **Continue** is displayed instead of **Start** when **Calculate alternative routes** is activated in the navigation menu (▷ page 349).

Personal POIs

General notes

-  Using personal POIs in order to display traffic surveillance equipment is not permitted in all countries. Please observe country-specific regulations and always drive at an appropriate speed.

Settings

Calling up the "Personal POIs" menu



"Personal POIs" menu

- ▶ **To switch on navigation mode:** press the **NAVI** function button.
- ▶ **To show the menu:** press the COMAND controller.
- ▶ Select **Navi** in the main function bar by sliding and turning the COMAND controller and press to confirm.
- ▶ Select **Personal POIs** and press to confirm.

Displaying personal POIs on the map

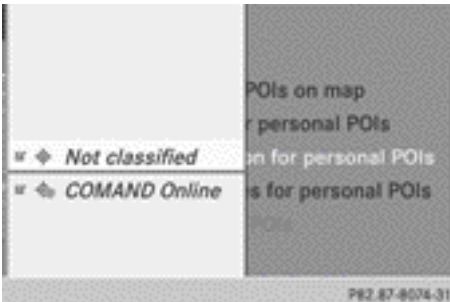

The personal POIs are shown on the map with an icon according to their category.

- ▶ Call up the "Personal POIs" menu ([▷ page 335](#)).
- ▶ Select **Display personal POIs on map** in the menu and press to confirm. You can select different categories.

Selection	Explanation
<input type="checkbox"/> Not classified	Standard entry for personal POIs
<input type="checkbox"/> COMAND Online	Personal POIs (destinations, routes) that you have imported via the online function (▷ page 433).

If you have created your own categories (e.g. "Café", "Top 10"), they are also displayed ([▷ page 336](#)).

- ▶ Select a category and press to confirm. The icon display is switched on or off , depending on the previous status.
- The icons are displayed on the 50 m, 100 m, 200 m and 500 m map scales.

Visual information for personal POIs



Example: visual information for a personal POI



If the vehicle is approaching a personal POI, this is highlighted on the map. The display for the corresponding category must be activated for this.

- ▶ Call up the "Personal POIs" menu ([▷ page 335](#)).
- ▶ In the "Personal POIs" menu, select **Visual warning for personal POIs** and press to confirm. The menu displays the available categories.

- ▶ Select a category and press  to confirm. This will switch the visual warning for all personal POIs of this category on or off , depending on the previous setting.

Acoustic notification for personal POIs

A gong sounds when the vehicle is approaching a personal POI. The function for the corresponding category must be activated for this.





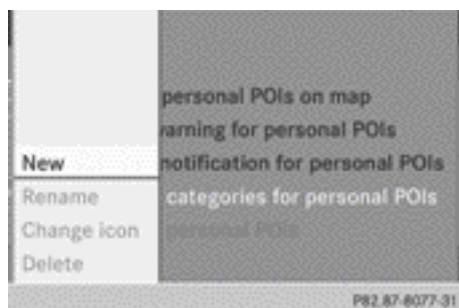

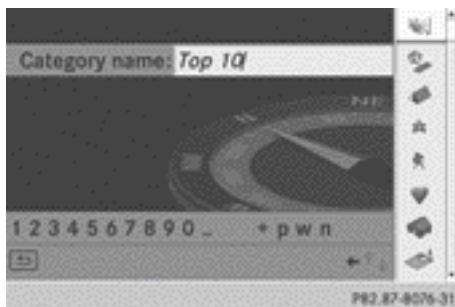

- ▶ Call up the "Personal POIs" menu ([▷ page 335](#)).
- ▶ In the "Personal POIs" menu, select **Acoustic notification for personal POIs** and press  to confirm. The menu displays the available categories.
- ▶ Select a category and press  to confirm. This will switch the acoustic notification for all personal POIs of this category on or off , depending on the previous setting.

Managing categories for personal POIs





- ▶ Call up the "Personal POIs" menu ([▷ page 335](#)).
- ▶ In the "Personal POIs" menu, select **Manage categories for personal POIs** and press  to confirm.



- ▶ **To create a new category:** select **New** and press  to confirm.
- ▶ Enter the name of the category. Character entry ([▷ page 298](#)).
- ▶ Select the  icon and press  to confirm. A list with icons appears. You can assign an icon to the category.
- ▶ Select an icon by turning  the COMAND controller and press  to confirm. You have created a new category with a name and icon. This category appears when selecting the display on the map or when selecting the destination.
- ▶ **To rename a category, to change an icon:** select **Rename** or **Change icon** and press  to confirm.
- ▶ Proceed as described under "To create a new category".
- ▶ **To delete a category:** select **Delete** and press  to confirm. A prompt appears asking whether the category should be deleted.
 - i** If you delete a category, all POIs of this category are also deleted.
- ▶ Select **Yes** and press  to confirm. If you select **Yes**, the category will be deleted. If you select **No**, the process will be aborted.

Managing personal POIs

- ▶ Call up the "Personal POIs" menu (▷ page 335).
- ▶ Select **Manage personal POIs** in the menu and press  to confirm.
- ▶ Select **Not classified, COMAND Online** or your own category and press  to confirm.
- ▶ Select a personal POI and press  to confirm.
The personal POI is displayed.

Observe further information concerning managing categories for personal POIs (▷ page 338):



- renaming
- changing the category
- deleting

Saving personal POIs







There are three ways of saving personal POIs. You must insert an SD memory card to do so. The **No memory card** message otherwise appears.

Personal POIs and routes are saved on the memory card in the same data format in which the geographical data is stored. This format is based on the open GPX (GPS Exchange) format.



Option 1

- ▶ Insert the SD memory card (▷ page 463).
 - ▶ **To switch on navigation mode:** press the  function button.
 - ▶ Hide the menu to show the map in full screen mode (▷ page 316).
 - ▶ Press  the COMAND controller for longer than two seconds.
The current position of the vehicle is saved as a personal POI on the SD memory card in the **Not classified** category.
- i** The crosshair position is saved in the scrolling map function (▷ page 364).

Option 2

- ▶ Insert the SD memory card (▷ page 463).
- ▶ **To switch on navigation mode:** press the  function button.
- ▶ **To show the menu:** press  the COMAND controller.
- ▶ Select **Position** in the navigation system menu bar by turning  the COMAND controller and press  to confirm.
- ▶ Select **Save position as pers. POI** or **Save crosshair pos. as personal POI** ("Move map" function active) and press  to confirm.
The list of personal categories appears.
- ▶ Select a category and press  to confirm.
- ▶ Enter the name for the personal POI. Character entry (▷ page 298).

Option 3

- ▶ Insert the SD memory card (▷ page 463).
- ▶ **To switch on navigation mode:** press the  function button.
- ▶ Call up the address entry menu (▷ page 318).
- ▶ Select **Save** from the address entry menu and press  to confirm.
- ▶ Select **Save as personal POI** and press  to confirm.
- ▶ Select a category.
- ▶ Enter the name.
The current address is saved as a personal POI on the SD memory card.

Importing personal POIs via the online function

You can import personal POIs (destinations, routes) via the online function (▷ page 433). When importing, you can choose whether to write files to the SD memory card or to file them in the address book. The imported personal POIs have their own icon and are filed in the **COMAND Online** category.

Selecting as the destination



- ▶ Insert the SD memory card (▷ page 463).
- ▶ **To switch on navigation mode:** press the **NAVI** function button.
- ▶ **To show the menu:** press the COMAND controller.
- ▶ Select **Destination** in the navigation system menu bar by turning the COMAND controller and press to confirm.
- ▶ Select **From personal POIs** and press to confirm.
The categories of personal POIs appear.

Selection	Explanation
Not classified	Standard entry for personal POIs.
COMAND Online	Personal POIs which you have imported via the online function (▷ page 433).
COFFEE SHOP	Icon and category that you have created yourself (▷ page 336).







In the example, the **COMAND Online** category is selected.

The personal POIs received are displayed.



- ▶ Select a personal POI and press to confirm.
- ▶ **To rename a personal POI:** select **Rename** and press to confirm.
- ▶ **To change the category:** select **Change category** and press to confirm.
- ▶ **To change to the map:** select **Map** and press to confirm.
The position of the personal POI is shown in the map.
- ▶ **To start route calculation:** select **Start** and press to confirm.
If route guidance has been activated, a prompt will appear asking whether you wish to accept the personal POI as the destination.

If route guidance has not been activated, route calculation for the personal POI will start immediately.

- ▶ Select **Yes** or **No** and press  to confirm. If you select **Yes**, the personal POI is accepted as the destination.
If you select **No**, the process will be aborted.
- ▶ **To make a call:** select **Call** and press  to confirm. COMAND Online switches to telephone mode (▷ page 392).
- ▶ **Call** is available if the personal POI has a telephone number and a mobile phone is connected to COMAND Online (▷ page 381).
- ▶ **To delete a personal POI:** select **Delete** and press  to confirm.
A prompt appears asking whether you wish to delete the POI.
- ▶ Select **Yes** or **No** and press  to confirm. If you select **Yes**, the personal POI is deleted.
If you select **No**, the process will be cancelled.

You can download available updates from the Mercedes-Benz webshop.

- ▶ You can also subsequently obtain travel guide data from the Mercedes-Benz Accessory webshop.

The travel guide offers you tourist destinations and routes:

- in the vicinity of the current vehicle position
- along the calculated route
- in the vicinity of the destination
- through selection on the map
- on a specific topic, for example, Paris, the Alps or German wine routes

You can select:

- which travel guide data on the map can be shown and selected (e.g. restaurants and tourist routes)
- whether information on tourist destinations is read out as you approach them

ViaMichelin travel guide

Overview



If COMAND Online offers the ViaMichelin travel guide in navigation mode, you can select tourist destinations, including routes. In this case, the travel guide data is on a SD memory card. First place the SD memory card in the SD card slot (▷ page 463).

Activating/deactivating travel guide data



Categories for the display of travel guide data on the map

Travel guide data is stored in categories, such as e.g. restaurants or tourist routes. In the menu, you can select which travel guide categories are shown on the map, and therefore which can be selected. You can also determine whether available information on the tourist destination of a particular category is acoustically provided as you approach it.

- ▶ **To switch to navigation mode:** press the **NAVI** button.
- ▶ **To show the menu bar:** press **☰** the COMAND controller.
- ▶ Select **Navi** in the main function bar by sliding **↑** and turning **⌚** the COMAND controller and press **☑** to confirm.
- ▶ Select **Travel guide** and press **☑** to confirm.

- ▶ Select **Map icons** or **Acoustic announcement** and press **☑** to confirm. The menu displays the available categories.

- ▶ Select a category and press **☑** to confirm. Switch the category on or off .

If you selected **Map icons** and switched on a category, you can select the available tourist destinations of that category on the map.

If you selected **Acoustic announcement** and switched on a category, you hear information as you approach a tourist destination. The information must be available as an audio file for this destination.

Calling up the travel guide

Using destination entry

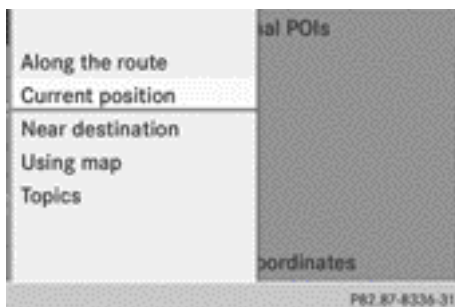
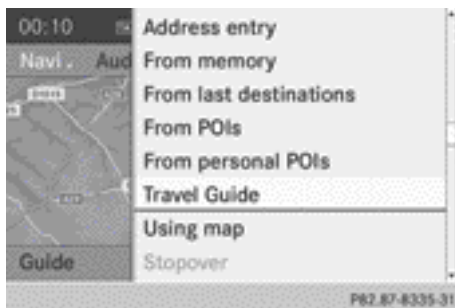

Selecting search position for travel guide (using destination entry)

- ▶ **To switch to navigation mode:** press the **NAVI** button.
- ▶ **To show the menu bar:** press **☰** the COMAND controller.

- ▶ Select **Destination** in the navigation system menu bar by sliding $\odot \downarrow$ and turning $\left[\odot \right]$ the COMAND controller and press \odot to confirm.
- ▶ Select **Travel Guide** and press \odot to confirm.
- ▶ **No destination has been entered yet:** select **Current position**, **Using map** or **Topics**.
- ▶ **A route has already been entered:** you can also select **Along the route** and **Near destination**.

Using the guide

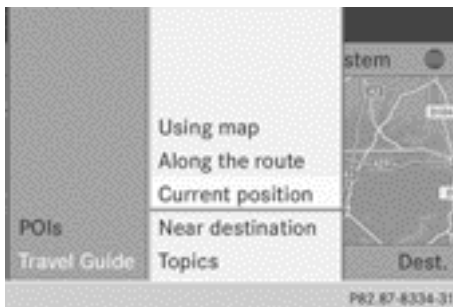
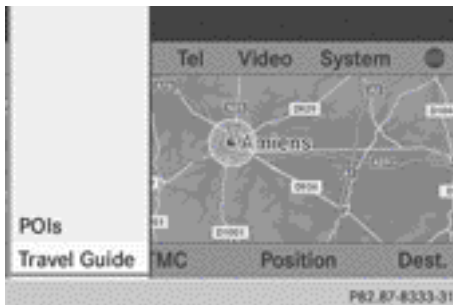

Selecting search position for travel guide (using guide)

- ▶ **To switch to navigation mode:** press the **NAVI** button.
- ▶ **To show the menu bar:** press \odot the COMAND controller.
- ▶ Select **Guide** in the navigation system menu bar by sliding $\odot \downarrow$ and turning $\left[\odot \right]$ the COMAND controller and press \odot to confirm.

- ▶ Select **Travel Guide** and press \odot to confirm.
- ▶ **No destination has been entered yet:** select **Current position**, **Using map** or **Topics**.
- ▶ **A route has already been entered:** you can also select **Along the route** and **Near destination**.

Selecting topics

You can choose from a variety of topics. Topics can be listed based on places (e.g. countryside) or on content (e.g. wine guide).

- ▶ Call up the travel guide (\triangleright page 340).
- ▶ Select **Topics**.
A list appears.
- ▶ Select a topic and press \odot to confirm.
The system selects a map view that allows the tourist destinations and routes for the topic to be displayed.
- ▶ Select a tourist destination or route on the map and press \odot to confirm.

Selecting a destination or a route on the map

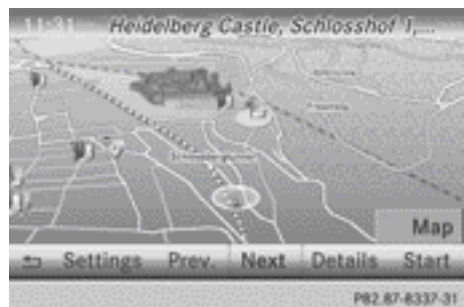

To select tourist destinations/routes, first select the search position and then the corresponding symbol on the map.

- ▶ Call up the travel guide (\triangleright page 340).
- ▶ Select a search position, e.g. **Using map**.
The map appears.
- ▶ Select a menu item and press \odot to confirm (see table).

Menu item	Explanation
Settings	In the settings, you can select which selectable travel guide data is shown on the map.
Prev. (previous) or Next	Highlights the previous or next symbol on the map.
Details	Shows detailed information about the destination or route. You may also use further functions, e.g. calling the hotel or listening to an audio file about the place of interest (if available).
Map	Switches to the map with the crosshair. You can slide the crosshair and change the map scale.
Start	Begins route calculation for the selected destination.

Exploring the destination or route

Before the route calculation, you can call up useful information on the selected destination.

- ❗ Not every tourist destination or route has images, texts or audio files available.



Destination address is displayed (example)

- ▶ Call up the travel guide (▷ page 340).
- ▶ Select a search position, e.g. [Using map](#). The map appears.
- ▶ Select [Details](#) and press to confirm. The destination address is shown.
- ▶ **To display images:** select [Images](#) and press to confirm. One or more photos of the tourist destination are shown.
- ▶ **To display text information:** select [Info](#) and press to confirm. A short text provides interesting details about the tourist destination.
- ▶ **To play an audio file:** select and press to confirm. You hear useful information about the tourist destination.
- ▶ To stop playback, select and press to confirm.
- ▶ **To call the destination:** select [Call](#) and press to confirm. If a mobile phone is connected to COMAND Online, the telephone function is activated and the call is connected (▷ page 392).
- ▶ **To start route calculation:** select [Start](#) and press to confirm.

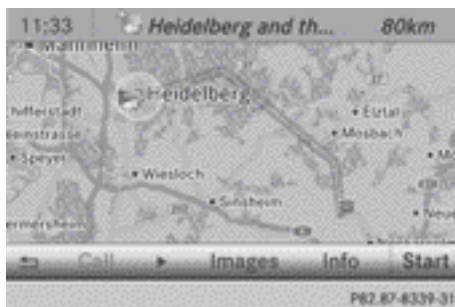

Example: tourist route is displayed

If you have selected a tourist route, the map shows an overview of the route.

Above, the following functions are described:

- displaying pictures
- showing text information

- playing an audio file
 - calling up the destination
- **To start route calculation:** select **Start** and press  to confirm.

Route guidance

Important safety notes

WARNING

COMAND Online calculates the route to the destination without taking account of the following, for example:

- traffic lights
- stop and give way signs
- parking or stopping restrictions
- road narrowing
- other road and traffic rules and regulations

COMAND Online may give incorrect driving recommendations if the data on the digital map does not correspond to the actual conditions, e.g. the road layout has changed.

For this reason, you must always observe road and traffic rules and regulations during your journey. Road and traffic rules and regulations always have priority over system driving recommendations.

Route guidance begins once a route has been calculated (► page 321).

COMAND Online guides you to your destination by means of navigation announcements in the form of audible navigation announcements and route guidance displays.

The route guidance displays can only be seen if the display is switched to navigation mode.

If you do not follow the navigation announcements or if you leave the calculated route, COMAND Online automatically calculates a new route to the destination.

If the digital map contains the corresponding information, the following applies:

- when selecting a route, COMAND Online tries to avoid roads that only have limited access, e.g. roads closed to through traffic.
- roads that have time restrictions (e.g. closed on Sundays and public holidays) are considered for route guidance on days when they are open. For this purpose, the relevant times must be correctly stored in the database.

Displays during route guidance

Change of direction

Changes of direction have three phases:

- preparation phase
- announcement phase
- change-of-direction phase

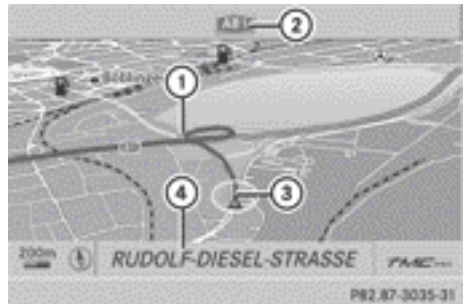

Example: preparation phase

- ① Point at which the change of direction takes place (light blue dot)
- ② Next road
- ③ Current vehicle position (the tip of the triangle indicates the vehicle's direction of travel)
- ④ Current road

Display ④ depends on the setting selected for "Map information in the display" (► page 366).

COMAND Online prepares you for the upcoming change of direction. Based on the example display below, the change of direction is

announced by the **Prepare to turn right** message. You see the full-screen map.

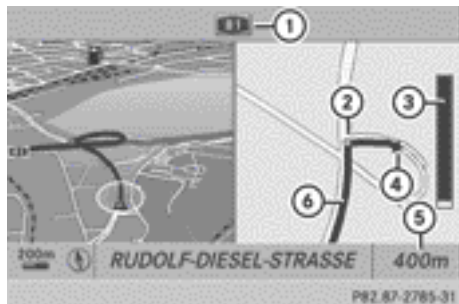

Example: announcement phase

- ① Next road
- ② Point at which the change of direction takes place (light blue dot, shown in both the left and right half of the display)
- ③ Graphic representation of the distance to the next change of direction
- ④ Change of direction (turn right here)
- ⑤ Distance to the next change of direction
- ⑥ Route (blue line, shown in both the left and right half of the display)

i The filled-in section of visual display for distance ③ gets shorter the nearer you get to the announced change of direction.

COMAND Online announces the imminent change of direction. Based on the example display below, the change of direction is announced beforehand by the message: **In 400 metres turn right onto the A81.**

The display is now split into two sectors. In the left half, you see the normal map view. The right half shows an enlarged section of the area around the junction (Crossing Zoom) or a 3D image of the road's course with the route indicating the next manoeuvre.

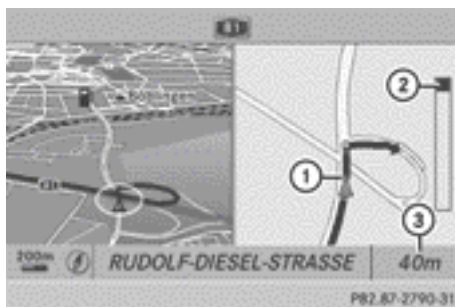

Example: change-of-direction phase

- ① Current vehicle position (the tip of the triangle indicates the vehicle's direction of travel)
- ② Graphic representation of the distance to the next change of direction
- ③ Distance to the next change of direction

COMAND Online announces the imminent change of direction.

Based on the example display below, the change of direction is announced 40 metres before the change of direction with the **Now turn right** message.

The display is split into two halves, as in the announcement phase.

Once the change of direction is completed, COMAND Online automatically switches back to full-screen display.

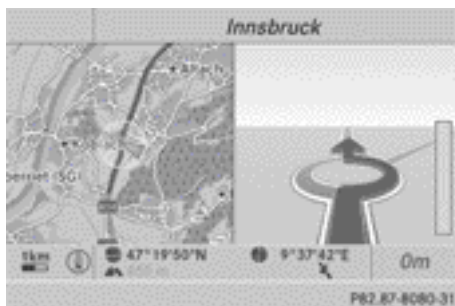

Example display: roundabout

Example of a display without a change of direction

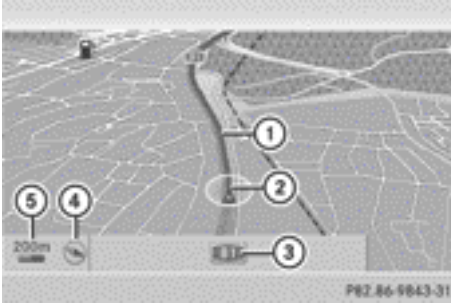

- ① Route (highlighted in blue)
- ② Current vehicle position
- ③ Current road
- ④ Map orientation selected
- ⑤ Map scale selected

- ⑨ Lanes not recommended (light brown)
- ⑩ Current vehicle position (the tip of the triangle indicates the vehicle's direction of travel)

On multilane roads, COMAND Online can display lane recommendations for the next change of direction. The corresponding data must be available on the digital map.

COMAND Online displays lane recommendation ⑥, based on the next two changes of direction. The number of lanes applies to the point at which the next change of direction is required.

- ① The multifunction display also shows lane recommendations.

Only the recommended lanes are displayed here, see the separate vehicle Owner's Manual.

Lane recommendations

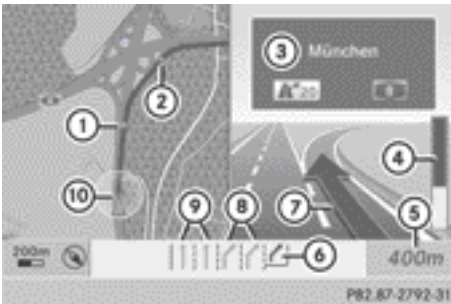

Example: lane recommendations

- ① Point of the next change of direction
- ② Point of the change of direction after next
- ③ Direction display, number of junction and of motorway
- ④ Graphic representation of the distance to the next change of direction
- ⑤ Distance to the next change of direction
- ⑥ Recommended lane (dark blue)
- ⑦ Next change of direction (in this case, exit to the right)
- ⑧ Possible lanes (light blue)

Display and description of lane recommendations

Lane	Day design	Night design
Recommended lane In this lane, you will be able to complete the next two changes of direction without changing lane.	Dark blue	Light blue
Possible lane In this lane, you will only be able to complete the next change of direction without changing lane.	Light blue	Dark blue
Lane not recommended In this lane, you will not be able to complete the next change of direction without changing lane.	Light brown	Grey

- i** The colours used in the lane recommendation display vary depending on whether day or night design is switched on.

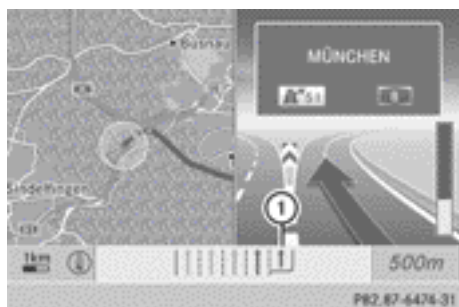

- ① New lane (dark blue)

During the change of direction, additional lanes may appear. These are displayed differently.



Example: day design

- ① The displayed lane recommendations apply to this position (light blue circle)



Example: night design

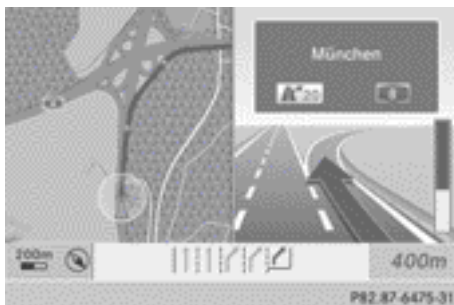





Example: lane recommendations at a motorway junction

Observe the route guidance information shown in the multifunction display, see the separate vehicle Owner's Manual.

Navigation announcements

Repeating navigation announcements





If you have missed an announcement, you can call up the current announcement at any time. However, no announcements are made during a phone call.

- ▶ **To show the menu:** press  the COMAND controller.
- ▶ Select  in the navigation system menu bar by turning  the COMAND controller and press  to confirm.

Switching navigation announcements off/on

- ▶ **To switch off:** press the  button during an announcement.

You will briefly see the message: **The guidance instructions have been muted.**





- ▶ **To switch on:** press  the COMAND controller.
- ▶ Select  in the navigation system menu bar by turning  the COMAND controller and press  to confirm.

i COMAND Online automatically switches the navigation announcements back on when:



- it receives RDS-TMC traffic reports during dynamic route guidance and recalculates the route accordingly (▷ page 355).
- you calculate a new route
- you switch COMAND Online on again or start the engine.

Reducing the volume during a navigation announcement

The volume of an active audio or video source can be automatically reduced during a navigation announcement.

- ▶ Select **Navi** in the main function bar by sliding  and turning  the COMAND controller and press  to confirm.
- ▶ Select **Audio fadeout** and press  to confirm.
The function is switched on or off , depending on the previous status.





Setting the volume manually

- ▶ Adjust the volume using the  control knob during a navigation announcement.
or
- ▶ Select  in the map view with the menu shown and adjust the volume using the  control knob.

Announcing the street names

If the function is switched on, the name of the street into which you should turn is announced.

Announcements are not made in the chosen language in all countries. They are made when relevant street names for the selected language are available in the database.

- ▶ **To switch on navigation mode:** press the  function button.
- ▶ **To show the menu:** press  the COMAND controller.
- ▶ Select **Navi** in the main function bar by sliding  the COMAND controller and press  to confirm.
- ▶ Select **Announce street names** and press  to confirm.
The function is switched on or off , depending on the previous status.

Street names may be announced in the following languages:

- Danish
- German
- English
- French
- Dutch

- Portuguese
- Swedish

Ending route guidance

Cancelling or continuing route guidance

► **To switch on navigation mode:** press the **NAVI** function button.

► **To show the menu:** press **⏸** the COMAND controller.

► Select **Destination** in the navigation system menu bar by turning **⏸** the COMAND controller and press **⏸** to confirm.

► **To cancel route guidance:** select **Cancel route guidance** and press **⏸** to confirm.

or

► **To continue route guidance:** select **Continue route guidance** and press **⏸** to confirm.

COMAND Online calculates the route.

Destination or area of destination reached

When you reach your destination, COMAND Online displays a chequered flag and route guidance is automatically ended.

If the destination is not in close proximity to a digitised street, the **Area of destination reached** message appears when the destination is reached.

Influencing route guidance

Avoiding a section of the route blocked by a traffic jam



① Length of the blocked route section

② Name of route section

③ Blocked route section

This function blocks a section of the route ahead of you. You can set the length of the blocked route section. If possible, COMAND calculates a detour around the blocked section of the route.

► **To switch on navigation mode:** press the **NAVI** function button.

► **To show the menu:** press **⏸** the COMAND controller.

► Select **Route** in the navigation system menu bar by turning **⏸** the COMAND controller and press **⏸** to confirm.

► Select **Detour** and press **⏸** to confirm.

► **To block a section of the route:** select **Longer** or **Shorter** repeatedly and confirm using **⏸** until the desired section has been selected.

i The total length of the section that can be blocked is defined by the digital map. The menu items are available accordingly.

► **To start route calculation:** select **Start** and press **⏸** to confirm.

- ▶ **To delete the blocked section:** select **Delete** while the message is shown and press  to confirm. COMAND Online calculates the route without the block.





Selecting an alternative route

With the "Alternative route" function, routes other than the original one can be calculated. Routes 1 to 3 are calculated with the current settings for the route type and route options and are shown with a dark blue line (▷ page 316).

Route 4 is the economic route (eco route) and is shown with a green line.

On the right-hand side, you will see information on the currently selected alternative route, e.g. distance, estimated remaining driving time and estimated time of arrival. Route sections used (e.g. motorways, tunnels) are displayed as symbols.





Option 1

- ▶ **To switch on navigation mode:** press the **NAVI** function button.
- ▶ **To show the menu:** press  the COMAND controller.
- ▶ Select **Route** in the navigation system menu bar by turning  the COMAND controller and press  to confirm.
- ▶ Select **Alternative route** and press  to confirm.



Examples for route 1 (above) and route 4 (eco route)

Option 2

- ▶ **To switch on navigation mode:** press the **NAVI** function button.
- ▶ **To show the menu:** press  the COMAND controller.
- ▶ Select **Navi** in the main function bar by sliding  the COMAND controller and press  to confirm.
- ▶ Select **Calculate alternative routes** and press  to confirm. The function is switched on or off , depending on the previous status. **Function is activated:** alternative routes are calculated directly after the destination is entered.

Menu functions

- ▶ **To select the next or previous alternative route:** select **Next** or **Previous** and press  to confirm.

- ▶ **To start route guidance using the selected alternative route:** select **Start** and press to confirm. COMAND Online begins route guidance on the selected alternative route.

Route information

Displaying destination information



Example: destination information

The example shows information on distance, estimated time of arrival and estimated remaining driving time to the destination and two way points.

- ▶ **To switch on navigation mode:** press the **NAVI** function button.
 - ▶ **To show the menu:** press the COMAND controller.
 - ▶ Select **Route** in the navigation system menu bar by turning the COMAND controller and press to confirm.
 - ▶ Select **Destination information** and press to confirm. Destination information is displayed.
 - ▶ **To call up further destination information:** turn the COMAND controller.
 - ▶ **To close the destination information:** slide the COMAND controller or press the back button.
- i** You can display destination information for the destination, for both waypoints and

the intermediate stop, if they are part of the route.

If a mobile phone is connected to COMAND Online and a phone number is included in the destination information, you can call it (▷ page 381).

Route overview





You can use the route overview to move along the active route section by section and view information and details about each section of the route.

At the top of the display, you will see information about the highlighted route section, for example the distance to be driven on the road and road designation. The highlighted route section is marked in white with a red border on the map.

- ▶ **To switch on navigation mode:** press the **NAVI** function button.
- ▶ **To show the menu:** press the COMAND controller.
- ▶ Select **Route** in the navigation system menu bar by turning the COMAND controller and press to confirm.









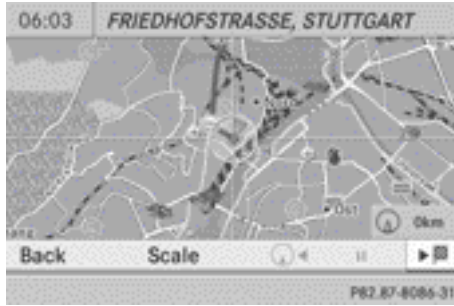

- ▶ Select **Route browser** and press to confirm.
 - ▶ **To view the next or previous route section:** select **Next** or **Previous** and press to confirm.
- i** If the first or last route section is highlighted, you cannot select **Previous** or **Next**.

- ▶ **To zoom in or out of the map:** select  or  and press  to confirm.
- ▶ **To close the route overview:** select [Back](#) and press  to confirm.

Route demonstration







You can see the route before starting your journey. This function is only available when the vehicle is stationary.

- ▶ **To switch on navigation mode:** press the  function button.
- ▶ **To show the menu:** press  the COMAND controller.
- ▶ Select [Route](#) in the navigation system menu bar by turning  the COMAND controller and press  to confirm.
- ▶ Select [Route demonstration](#) and press  to confirm.
The map with the crosshair appears.
- ▶ **To get to the destination:** press  to confirm the highlighted symbol.
- ▶ **To stop the route demonstration:** confirm the  symbol by pressing .



Example: route demonstration stopped

- ① Display of street name and city when route demonstration is paused
 - ② Distance of the crosshair from current vehicle position
- ▶ **To get to the current vehicle position:** press  to confirm the symbol for the current vehicle position.
 - ▶ **To change the map scale:** select [Scale](#) and press  to confirm.
The scale bar appears.
 - ▶ Turn  the COMAND controller and press  to confirm.

Recording the route

Notes

If you have activated COMAND Online and the SD memory card has been inserted, you should not take it out of the slot.

When you record a route, COMAND Online uses so-called support points and displays the route as a series of lines. If the route is then calculated, COMAND Online attempts to align the recorded route with the digital map. The support points of the route may not be on a digitised road.

This is often the case with routes which are drawn up using other map data and imported via the online function, e.g.:

- routes from the Google™ Local Search (▷ page 428)
- routes from the destination/route download (▷ page 433)

Call up the "Routes" menu

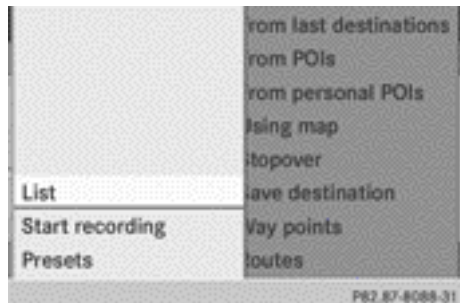

- ▶ Insert the SD memory card (▷ page 463).
- ▶ **To switch on navigation mode:** press the **NAVI** function button.
- ▶ **To show the menu:** press **⏸** the COMAND controller.
- ▶ Select **Destination** in the navigation system menu bar by turning **⏸** the COMAND controller and press **⏸** to confirm.
- ▶ Select **Routes**.

Starting/ending recording

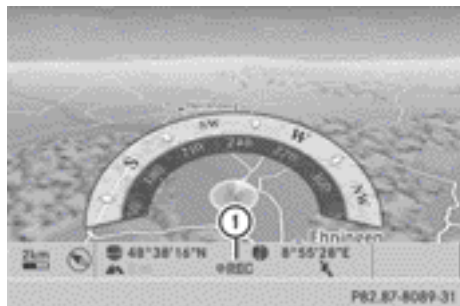

- ① To indicate recording has started (REC is red)
- ▶ Calling up the "Routes" menu (▷ page 352).
- ▶ **To start recording:** select **Start recording** in the "Routes" menu by turning **⏸** the COMAND controller and press **⏸** to confirm. The route is recorded and entered in a list.
 - **REC** is displayed in red ①.

- ▶ **To stop recording:** select **Stop recording** in the "Routes" menu by turning **⏸** the COMAND controller and press **⏸** to confirm.

Displaying and editing the recorded route

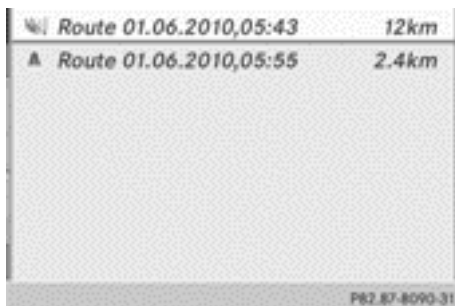



- ▶ Insert the SD memory card (▷ page 463).
- ▶ Calling up the "Routes" menu (▷ page 352).
- ▶ Select **List** in the "Routes" menu by turning **⏸** the COMAND controller and press **⏸** to confirm. Previously recorded routes are displayed.



- ▶ Select a route and press **⏸** to confirm. The map appears with a menu. The recorded route is shown in the map with a blue dotted line.
- ▶ **To see a demonstration of the route on the map:** select **Demo** by turning **⏸**



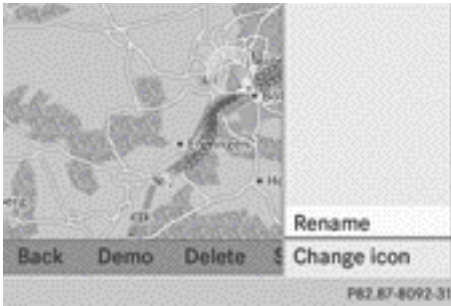

COMAND controller and press  to confirm.

The map with the crosshair appears.

- ▶ Proceed as described in the "Route demonstration" section (▷ page 351).
- ▶ **To begin route calculation:** select **Start** in the menu by turning  the COMAND controller and press  to confirm. COMAND Online attempts to align the recorded route with the digital map.







Changing route names and icons

- ▶ Select **Edit** in the menu by turning  the COMAND controller and press  to confirm.
- ▶ **To change the route name:** select **Rename** and press  to confirm.
 -  The name cannot be changed while the vehicle is in motion.
- ▶ **To change the icon:** select **Change icon** and press  to confirm.

Please see the further information on administering POI categories (▷ page 336).



To change direction for route calculation: you can set the icon for the route to the starting point or to the destination, thereby changing the direction for route calculation. During route calculation, one-way streets or turn restrictions, for example, are taken into account. Therefore, the outward and return routes may differ from each other.

- ▶ Select **Swap** in the menu by turning  the COMAND controller and press  to confirm.
- ▶ **To delete a route:** select **Delete** in the menu by turning  the COMAND controller and press  to confirm. A prompt appears asking whether the route should be deleted.
- ▶ Select **Yes** or **No** and press  to confirm. If you select **Yes**, the route will be deleted. If you select **No**, the process will be cancelled.

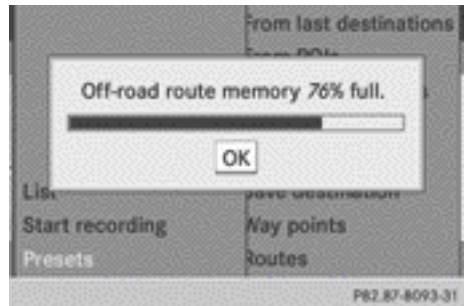
Scanning the memory



The SD memory card is inserted.

- ▶ Calling up the "Routes" menu (▷ page 352).
- ▶ Select **Presets** in the "Routes" menu by turning  the COMAND controller and press  to confirm. The route memory is displayed.

Off-road and off-map

Route guidance to a destination that is not on a digitised road

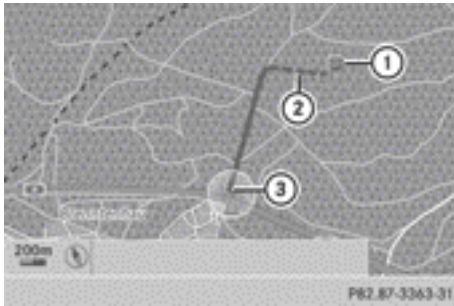

Example: route guidance to an off-road destination

- ① Off-road destination
- ② Off-road route section (dashed blue)
- ③ Current vehicle position (the tip of the triangle indicates the vehicle's direction of travel)

COMAND Online can guide you to destinations which are within the area of the digital map, but which are not themselves recorded on the map.

These destinations are known as off-road destinations, which you can enter using the map, for example. In these cases, COMAND Online guides you for as long as possible with navigation announcements and displays on roads known to the system.

Shortly before you reach the last known point on the map, you will hear the "Area of destination reached" announcement. The display shows a direction arrow with the linear distance to the destination.

Route guidance from an off-road location to a destination

If the vehicle position is within the area covered by the digital map, but the map does not contain any information about that location, the vehicle is in an off-road location.

COMAND Online is also able to guide you to a destination even from an off-road location.

At the start of the route guidance, you will see the **Off road** message, an arrow and the dis-

tance to the destination. The arrow shows the compass heading to the actual destination.

The route is highlighted blue, starting from the last recognised street the vehicle was on before it left the map.

As soon as the vehicle is back on a road known to the system, route guidance continues in the usual way.

Route guidance from an off-map location to a destination

If the vehicle position is outside the area covered by the digital map, then the vehicle is in an off-map location. COMAND Online is also able to guide you to a destination even from an off-map location.

At the start of the route guidance, you will see the **Off road** message, an arrow and the distance to the destination. The direction arrow shows the compass heading to the destination.

The route is highlighted blue from the nearest road known to the system.

As soon as the vehicle is back on a road known to the system, route guidance continues in the usual way.

Off-road during route guidance

Due to roadworks, for example, there may be differences between the data on the digital map and the actual course of the road.

In such cases, the system will temporarily be unable to locate the vehicle position on the digital map. The vehicle is therefore in an off-road position.

In the display, you will see the **Off road** message, an arrow and the distance to the destination. The direction arrow shows the compass heading to the destination.

As soon as the system can assign the vehicle position to the map again, route guidance continues in the usual way.

Dynamic route guidance

Introduction

An RDS-TMC radio station transmits RDS-TMC traffic reports in addition to the radio programme. COMAND Online can receive RDS-TMC traffic reports and take them into consideration for dynamic (traffic-dependent) route guidance. The navigation system can, for example, guide you around a traffic jam.

In Germany, COMAND Online uses high-quality traffic data for the traffic jam warning service TMCPPro. In contrast to the public TMC service, TMCPPro uses exclusive traffic data that is detected with an automated sensor network, in addition to the messages generated by the TMC service. The traffic data received from the traffic jam warning services named above could differ.

There may also be differences between the traffic reports received and the actual road and traffic conditions.

The respective traffic data being received appears at the bottom right of the display with the symbols "TMCPPro" or "TMC". If there is no reception, no symbol is displayed.

i RDS-TMC is not available in all countries.

Switching dynamic route guidance on/off

► **To switch on:** select the **Dynamic route** route type (► page 316).

► **To switch off:** select the **Fast route** or **Short route** route type (► page 316).

i COMAND Online calculates a new route if you change the route type setting when route guidance is active. If you change the route type setting when route guidance is inactive, COMAND Online uses the new setting for the next route guidance.

RDS-TMC displays on the map

COMAND Online can display certain traffic incidents on the map. The displays can be shown in map scales of 50 m to 20 km.

► **To set the map scale:** turn  the COMAND controller until the desired map scale is set.
Turning clockwise zooms out from the map; turning anti-clockwise zooms in.



Example: traffic reports on the map

i The display shows the entire affected route section with the corresponding symbols, regardless of how long the incident actually is. The symbols are placed on the side of the carriageway affected by the incident.



RDS-TMC symbols

- ① Traffic jam on the route
- ② Slow-moving traffic on the route
- ③ Road blocked
- ④ Road blocked

- ⑤ Slow-moving traffic (yellow cars along the affected route)
- ⑥ Traffic jam (red cars along the affected route)

Displaying RDS-TMC traffic reports

Displaying the report list

► **To switch on navigation mode:** press the **NAVI** function button.

► **To show the menu:** press **⏻** the COMAND controller.

► Select **TMC** in the navigation system menu bar by turning **⏻** the COMAND controller and press **⏻** to confirm. COMAND Online scans for RDS-TMC stations within receiver range.

No RDS-TMC station found: a message to this effect appears.

► To close the message: confirm **OK** by pressing **⏻** the COMAND controller.

RDS-TMC station found: COMAND Online scans for traffic reports.

If there are no traffic reports, you will see a message to this effect.

► To close the message: confirm **OK** by pressing **⏻** the COMAND controller.

If there are traffic reports, you will see a list. The content of the list depends on whether route guidance is active.

List when route guidance is not active

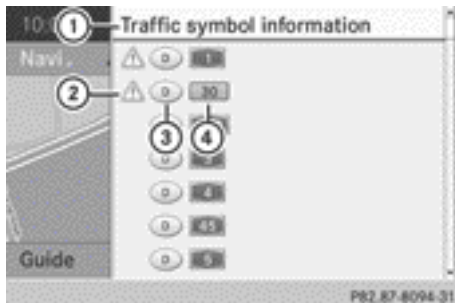

- ① To call up traffic symbol information
- ② Symbol for warning message
- ③ Country designation
- ④ Road affected

The list shows all the roads, areas or regions for which reports are available.

i A report may also relate to an area or region rather than a road, e.g. impaired visibility due to fog.

► **To show a traffic report:** select a road (area, region) by turning **⏻** the COMAND controller and press **⏻** to confirm. You can find an example of a traffic report here: (▷ page 357).

► **To display traffic symbol information:** select **Traffic symbol information** by turning **⏻** the COMAND controller and press **⏻** to confirm.



Example display

- ① Affected section of motorway
- ② Symbol for incident (traffic jam in the example shown)
- ③ Symbol display for the section of route affected

► **To show the next/previous incident:** select **Next** or **Previous** (if available) and press to confirm.

► **To show the detailed view:** select **Details** and press to confirm.

► **To scroll the map:** select **Map** and press to confirm.
You can scroll the map to have further traffic reports displayed (▷ page 364).

List when route guidance is active

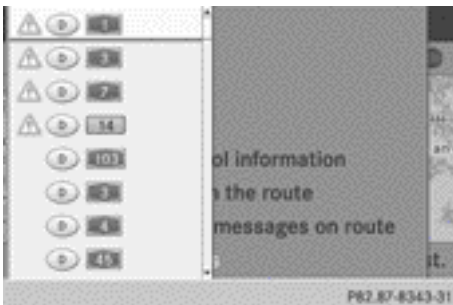

Example: list displaying all currently available traffic reports

► **To show all traffic reports:** select **Display all messages** and press to confirm.

A list is shown containing all roads, areas or regions affected by traffic reports.

Roads, areas or regions not on the route also appear in the list.

► **To show messages on the route:** select **Messages on the route** and press to confirm.

The list shows roads along the route for which there are traffic reports.

► **To show a traffic report:** select a road, an area or a region and press to confirm.
You can find an example of a traffic report here: (▷ page 357).

► **To exit the list:** slide to the COMAND controller once or several times.

Other functions:

- Displaying traffic symbol information (▷ page 356)
- Reading out traffic reports on the route (▷ page 358)

Example message



- ① Country designation, road designation, direction information and report 1/2 for the affected road
- ② Route section for which the traffic report applies
- ③ Traffic report
- ④ Type of traffic report (warning message)



PSZ 60-6788-31

- ① Traffic jam
- ② Slow-moving traffic
- ③ Warning message
- ④ Road blocked

The symbols for possible report types are shown.

► **To scroll within a report or to access the next report:** turn the COMAND controller.

► **To return to the list of messages:** press or slide the COMAND controller.

Reading out traffic reports on the route

Calling up traffic reports

The read-aloud function is only available when route guidance is active.

You can select from the following read-aloud properties:

- language (▷ page 306)
- text reader speed (▷ page 305)
- **To switch on navigation mode:** press the function button.
- **To show the menu:** press the COMAND controller.
- Select **TMC** in the navigation system menu bar by turning the COMAND controller and press to confirm.
- Select **Read out all messages on route** and press to confirm. COMAND Online reads out the messages in sequence.
- ❗ **The Read out all messages on route menu item has no function if there are no reports relating to the route.**

► **To cancel the read-aloud function:** select **Cancel read-aloud function** and press to confirm.

The current traffic report is read out to the end and then the function is deactivated.

or

► Briefly press the button. The function is deactivated immediately.

❗ COMAND Online interrupts the read-aloud function automatically as it recalculates the route following a new RDS-TMC traffic report.

Automatic read-aloud function

You can have TMC traffic reports on your route read aloud automatically. Announcements are made as you approach traffic incidents.

► **To switch the automatic read-aloud function on/off:** select **Navi** in the main function bar by sliding and turning the COMAND controller and press to confirm.

► Select **Read traffic messages automatically** and press to confirm. The function is switched on or off , depending on the previous status.

Destination memory





Home address (My address)

Entering the home address via address entry

- Proceed as described under "Adopting an address book entry as a home address" (▷ page 359). Confirm **My address** by pressing .
- **To enter the home address for the first time:** confirm **New entry** by pressing .
- **To change the home address:** select **Change** in the menu showing the home address by turning the COMAND controller and press to confirm.

- ▶ Confirm **New entry** by pressing .
- ▶ In both cases, enter the home address as a destination, e.g. as a town, street and house number (▶ page 318). Then, save the home address (▶ page 321).

Adopting an address book entry as a home address

- ▶ **To switch on navigation mode:** press the  function button.
- ▶ **To show the menu:** press  the COMAND controller.
- ▶ Select **Dest.** in the navigation system menu bar by turning  the COMAND controller and press  to confirm.
- ▶ Select **From memory** and press  to confirm.
You will see the destination memory list either with the character bar (option 1) or as a selection list (option 2).

Option 1: destination memory list with character bar





- ① Entry containing data that can be used for navigation
 - ② To call up options
- ▶ Slide  the COMAND controller repeatedly until the destination memory list appears as a selection list.

Option 2: destination memory list as a selection list







The **My address** entry is listed as the first entry in the destination memory.

- ▶ Select **My address** by turning  the COMAND controller and press  to confirm.

i If you have not yet entered any characters, **My address** is automatically highlighted in the selection list.

If no home address has been stored yet, you can now assign an address book entry. If a home address already exists, it is displayed and you can alter it.

i If you select **New entry**, you are also offered the option of entering the home address for the first time. You can then save the home address without having to start route guidance.

- ▶ **To enter the home address for the first time:** select **Assign address book entry** and press .
- ▶ Select **Home, Work** or **Not classified** and press .
- ▶ **To change the home address:** select **Edit** and press .
- ▶ Select **Assign to address book entry** and press .

i If you select **New entry**, you are also offered the option of changing the home address by entering an address. You can

then save the home address without having to start route guidance.

- ▶ Select **Home**, **Work** or **Not classified** and press  to confirm.

In both cases, you will see the address book either with the character bar or as a selection list.

- ▶ Select an address book entry (▷ page 407).
- ▶ **To confirm the selection:** press  the COMAND controller.
If there is no existing home address, COMAND Online saves the entry. You will see a message and then the address menu with the selected address. **Start** is highlighted automatically.

If a home address has already been stored, you will see a prompt asking you whether the **My address** entry should be overwritten.

- ▶ Select **Yes** or **No** and press  to confirm.
If you select **Yes**, COMAND Online overwrites the destination. You will see a message and then the address menu with the selected address. **Start** is highlighted automatically.
If you select **No**, the list will appear again.

Selecting the home address for route guidance

- ▶ Proceed as described under "Selecting a destination from the destination memory" (▷ page 323).



Saving a destination

General notes





This function also stores the destination in the address book.

When the address book is full, no destinations can be saved in the destination memory. You must first delete address book entries (▷ page 407).







After destination entry

- ▶ The destination has been entered and is shown in the address entry menu (▷ page 318).
- ▶ Select **Save** by sliding  and turning  the COMAND controller and press  to confirm.
You can now select storing options (▷ page 361).

During route guidance

- ▶ **To show the menu:** press  the COMAND controller.
- ▶ Select **Dest.** in the navigation system menu bar by turning  the COMAND controller and press  to confirm.
- ▶ Select **Save destination** and press  to confirm.
You can now select storing options (▷ page 361).

From the list of previous destinations

- ▶ **To show the menu:** press  the COMAND controller.
- ▶ Select **Dest.** in the navigation system menu bar by turning  the COMAND controller and press  to confirm.
- ▶ Select **From last destinations** and press  to confirm.
The list of previous destinations appears.
- ▶ Select a destination by turning  the COMAND controller and press  to confirm.
The destination address is shown.
- ▶ Select **Save** and press  to confirm.
You can now select storing options (▷ page 361).

Selecting storing options

Once you have chosen one of the following options for storing a destination, you can specify storage options:

- After destination entry (▷ page 360)
- During route guidance (▷ page 360)
- From the list of previous destinations (▷ page 324)

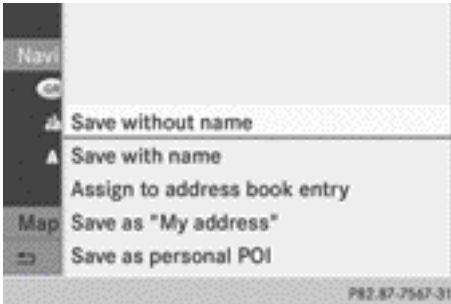

Storage options

- ▶ **To save the destination without a name:** select **Save without name** and press to confirm.
COMAND Online stores the destination in the destination memory and uses the address as the destination name.
- ▶ **To save the destination as My address:** select **Save as "My Address"** and press to confirm.
COMAND Online stores the destination in the destination memory as **My address**. If the selected address book entry already contains address data that can be used for navigation (icon), a prompt will appear asking whether you wish to overwrite the existing data.
- ▶ Select **Yes** or **No** and press to confirm.
If you select **Yes**, the entry is overwritten. If you select **No**, the process will be cancelled.
- ▶ **To save the destination with a name:** select **Save with name** and press to confirm.

- ▶ Select a category, e.g. **Home**, and press to confirm.
- ▶ The input menu appears with data fields and the character bar.

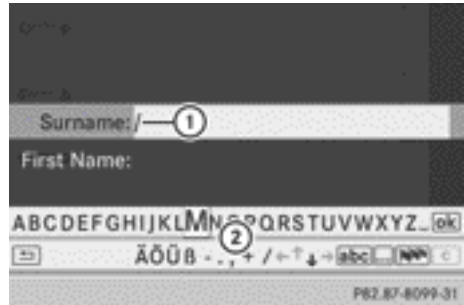

Example: saving a destination with a name

- ① Selected data field with cursor
- ② Character bar
- ▶ Proceed as described under "Character entry (navigation)" (▷ page 300).
- ▶ Then select **ok** and press to confirm.
COMAND Online stores the destination under the name entered.

Assigning a destination to an address book entry

An address with complete address data that is suitable for navigation can be assigned to a pre-existing address book entry.

- ▶ Select **Assign to address book entry** from the storage options and press to confirm.
- ▶ Select a category, e.g. **Home**, and press to confirm.
You will see the address book either with the character bar or as a selection list.
- ▶ Select an address book entry (▷ page 407).
COMAND Online stores the data if the address book entry selected does not yet contain navigable address data.
If the selected address book entry already contains navigable address data, a prompt

will appear asking whether you wish to overwrite the existing data.



- ▶ Select **Yes** or **No** and press  to confirm. If you select **Yes**, COMAND Online stores the data.

You can start route guidance to this address directly from the address book (▷ page 409).

Deleting a destination or the home address



- ▶ **To switch on navigation mode:** press the  function button.

- ▶ **To show the menu:** press  the COMAND controller.



- ▶ Select **Dest.** in the navigation system menu bar by turning  the COMAND controller and press  to confirm.

- ▶ Select **From memory** and press  to confirm. You will see the destination memory list either with the character bar (option 1) or as a selection list (option 2).

- ▶ **Option 1: destination memory list with the character bar:** enter characters using the character bar (▷ page 300).

- ▶ **Option 2: destination memory list as selection list:** select a destination by turning  the COMAND controller and press  to confirm.

You see the address data of the selected entry.

- ▶ Select **Delete** and press  to confirm. A prompt appears asking whether you wish to delete the destination.
- ▶ Select **Yes** or **No** and press  to confirm. If you select **Yes**, COMAND Online deletes the destination. You will see a message to this effect.

If you select **No**, the process will be cancelled.

- ▶ **i** If the navigable address data for the destination being deleted is also assigned to an address book entry, COMAND Online will also delete this data from there. If the corresponding address book entry does not contain any further data, such as telephone numbers, COMAND Online deletes the entire address book entry.

Last destinations





Introduction

COMAND Online automatically stores the previous destinations for which route calculation has been started. If the memory is full, COMAND Online deletes the oldest destination. You can also save a destination from the list of previous destinations in the destination memory. It will be stored there permanently.

Storing a destination permanently in the destination memory

- ▶ Proceed as described in the "From the list of previous destinations" section (▷ page 324).

Storing the vehicle position in the list of previous destinations

- ▶ **To switch on navigation mode:** press the  function button.
- ▶ **To show the menu:** press  the COMAND controller.
- ▶ Select **Position** in the navigation system menu bar by turning  the COMAND controller and press  to confirm.
- ▶ Select **Save vehicle position** and press  to confirm. COMAND Online stores the current vehicle position as a destination in the list of previous destinations.

Storing the crosshair position in the list of previous destinations

A crosshair appears on the map if you have moved the map manually (▷ page 364). You can store the crosshair position as a destination in the list of previous destinations.

- ▶ **To show the menu:** press the COMAND controller.
- ▶ Select **Position** in the navigation system menu bar by turning the COMAND controller and press to confirm.
- ▶ Select **Save crosshair position** and press to confirm.

Deleting a previous destination

- ▶ **To switch on navigation mode:** press the **NAVI** function button.
- ▶ **To show the menu:** press the COMAND controller.
- ▶ Select **Destination** in the navigation system menu bar by turning the COMAND controller and press to confirm.
- ▶ Select **From last destinations** and press to confirm.
The list of previous destinations appears.
- ▶ Select the desired destination and press to confirm.
The destination address appears.
- ▶ Select **Delete** and press to confirm.
A prompt appears asking whether the entry should be deleted.
- ▶ Select **Yes** or **No** and press to confirm.
If you select **Yes**, the entry is deleted.
If you select **No**, the process will be cancelled.

Map operation and map settings

General notes

Company logos displayed on the map are trademarks of the respective companies and

used solely for the purpose of indicating the locations of these companies. The use of such logos on the map does not indicate approval of, support of or advertising by these companies for the navigation system itself.

Setting the map scale



- ① Currently set map scale expressed as a number with unit, in this case 500 m
- ② Currently set map scale as indicated by the needle on the scale bar
- ③ New map scale
- ④ Scale bar

Unit of measurement ① in the COMAND display depends on the selection made for the instrument cluster; see the separate vehicle Owner's Manual.

- ▶ **To hide the menu:** slide the COMAND controller and, when the **Full screen** menu item is shown, press .
- ▶ **To call up the scale bar:** as soon as you turn the COMAND controller, scale bar ④ appears.
- ▶ Turn until the desired scale is set.

Moving the map

Showing the crosshair

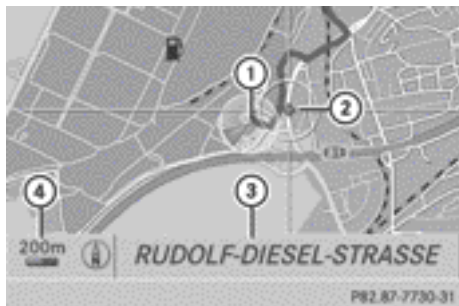

Map with crosshair

- ① Current vehicle position
- ② Crosshair
- ③ Details of the crosshair position
- ④ Map scale selected

► **To hide the menu:** slide \uparrow \odot the COMAND controller and, when the **Full screen** menu item is shown, press \odot .

► **To scroll the map:** slide \leftarrow \rightarrow , \uparrow \downarrow or \swarrow \searrow the COMAND controller.

A crosshair appears on the map. If you slide it again, the map moves in the corresponding direction under the crosshair.

Display ③ may be the name of a street, for example, provided the digital map contains the necessary data. It shows the geo-coordinate position of the crosshair if the **Geo-coordinates** display is switched on (► page 366).

Hiding the crosshair and centring the map on the vehicle position or destination

► Press the \leftarrow back button twice.
The crosshair disappears and the map is set to the vehicle position.

Centring the map on the vehicle's position

► **To show the menu:** press \odot the COMAND controller.

► Select **Position** in the navigation system menu bar by sliding \odot \downarrow and turning $\left\{ \odot \right\}$

the COMAND controller and press \odot to confirm.

► Select **Vehicle position map** and press \odot to confirm or, if the crosshair is shown, press the \leftarrow back button.
This hides the crosshair.

Centring the map on the destination position

This function requires that a route to a destination has been calculated. If the route has waypoints and an intermediate stop, the map can also be set to these positions.

► **To show the menu:** press \odot the COMAND controller.

► Select **Position** in the navigation system menu bar by sliding \odot \downarrow and turning $\left\{ \odot \right\}$ the COMAND controller and press \odot to confirm.

► Select **Destination position map** and press \odot to confirm.

The crosshair is centred on the respective destination.

Map settings

Calling up the Map settings menu

Route settings	Map orientation
Map settings	POI symbols on map
Personal POIs	Text information on map
◦ Read TMC-Mess	◦ Topographic map
◦ Announce street	◦ Motorway information
◦ Audio fadeout	◦ City (3D)
◦ Calculate alternate	◦ Next intersecting street
Avoid area	Compass on map

► **To show the menu:** press \odot the COMAND controller.

► Select **Navi** in the main function bar by sliding \uparrow \odot and turning $\left\{ \odot \right\}$ the COMAND controller and press \odot to confirm.

- ▶ Select **Map settings** and press to confirm.
The Map settings menu appears.

Map orientation

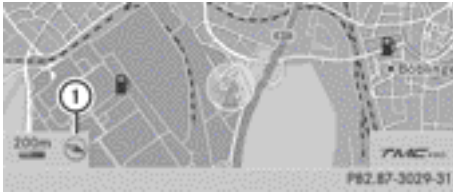

Example: map orientation

- ① Current map orientation (or

Possible map orientations:

- North orientation (the map view is displayed so that north is always up)
- Orientation in direction of travel (the map is displayed so that the direction of travel is always up; the orange point of the icon points north)
- Bird's-eye view (the map is displayed so that the direction of travel is always up; the map projection reproduces the curvature of the earth and the orange point of the icon points north)
- 3D map (the map is displayed so that the heading is always up; from a scale of 1 km the map displays elevation; the orange point of the icon points north).

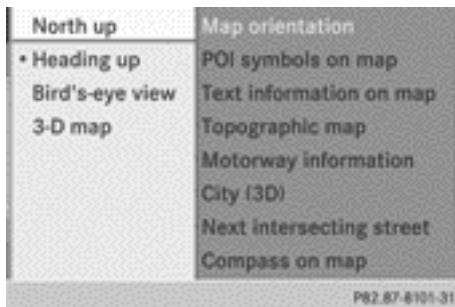

Map orientation menu

Setting the map orientation

- ▶ **To show the menu:** press the COMAND controller.

- ▶ Select **Navi** in the main function bar by sliding and turning the COMAND controller and press to confirm.
- ▶ Select **Map settings** and press to confirm.
The Map settings menu appears.
- ▶ Select **Map orientation** and press to confirm.
- ▶ Select **North up**, **Heading up**, **Bird's-eye view** or **3-D map** by turning the COMAND controller and press to confirm.
A ● dot indicates the new setting.

Selecting POI symbols

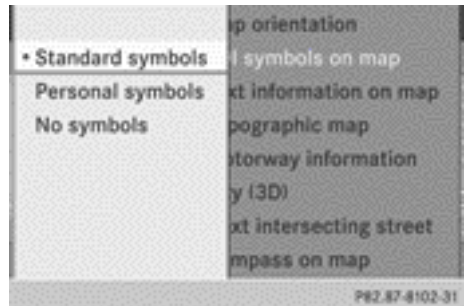

Setting the POI symbol display

You can set the POIs you wish to have displayed as symbols on the map. POIs are, for example, filling stations, hotels, cinemas and restaurants.

- ▶ **To show the menu:** press the COMAND controller.
- ▶ Select **Navi** in the main function bar by sliding and turning the COMAND controller and press to confirm.
- ▶ Select **Map settings** and press to confirm.
The Map settings menu appears.
- ▶ Select **POI symbols on map** and press to confirm.

The following settings are possible:

- **Standard symbols**

Symbol display determined by the factory settings.

- **Personal symbols**

You can determine the symbols yourself.

- **No symbols**

The map does not show any symbols.



- ▶ Select **Standard symbols**, **Personal symbols** or **No symbols**.

If you select **Personal symbols**, the POI list appears.

- ▶ **To switch the symbol display on/off:** select a POI by turning **⏪** the COMAND controller and press **⏩** to confirm.

Depending on the previous state of the symbols, they will either be shown or hidden . You can switch on the icon displays for more than one POI.

- ▶ **To switch all personal symbols on/off:** select **All** and press **⏩** to confirm.

Depending on the previous status of the symbols, they will either be shown or hidden .

If the function is switched on , the individual POIs are greyed out and the previously selected settings remain unchanged.

If the function is switched off , you can reselect the individual POIs. This indicates the previous settings.

- i** The list shows all symbols that are contained on the digital map across all countries. However, not all POIs are available in all countries. As a result, certain POI symbols may not be displayed on the map, even if the symbol display is switched on.

- ▶ **To exit the menu:** press the **⏪** back button.

Selecting map information

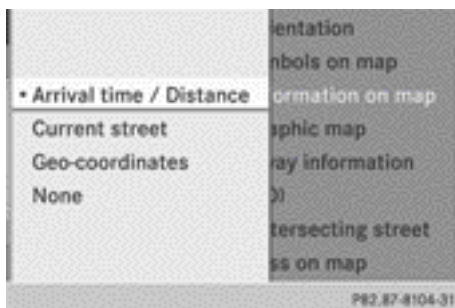

Map information in the display

During route guidance, you can have map information displayed at the bottom edge of the display.

- ▶ **To show the menu:** press **⏩** the COMAND controller.

- ▶ Select **Navi** in the main function bar by sliding **⏪** and turning **⏩** the COMAND controller and press **⏩** to confirm.

- ▶ Select **Map settings** and press **⏩** to confirm.

The Map settings menu appears.

- ▶ Select **Text information on map** and press **⏩** to confirm.

A • dot indicates the current setting.

- ▶ Select **Arrival time / Distance**, **Current street**, **Geo-coordinates** or **None** and press **⏩** to confirm.

- ▶ **To exit the menu:** slide **⏪** the COMAND controller.



Arrival time/distance to destination display

- ① Icon for destination
- ② Distance to destination
- ③ Estimated time of arrival

You can only see this display during route guidance.

While moving the map, you will see additional data depending on the crosshair position if the digital map supports this data. This might be a street name, for example.

During route calculation, or if the vehicle is travelling on a road not in the map data, the linear distance to the destination is shown. In this case, the display will be greyed out.



Road display

- ① Road name or designation



Geo-coordinate display

- ① Current height above average sea level (rounded to the nearest 10 m)
- ② Current vehicle position: latitude coordinates
- ③ Current vehicle position: longitude coordinates
- ④ Number of GPS satellites currently being used

- ③ Current vehicle position: longitude coordinates
- ④ Number of GPS satellites currently being used

There must be sufficient GPS reception for all displays to be shown. If this is not the case, the display will be greyed out. Height display ① may vary from the actual value, because the navigation system uses the GPS signals for the calculation.

During the "Move map" function, you will see the geo-coordinates of the crosshair position. Height display ① and number of satellites used ④ are not displayed.



Display switched off



- ① Current map orientation

While moving the map, you will see additional data, e.g. road names, depending on the crosshair position, if the digital map supports this data (> page 364).

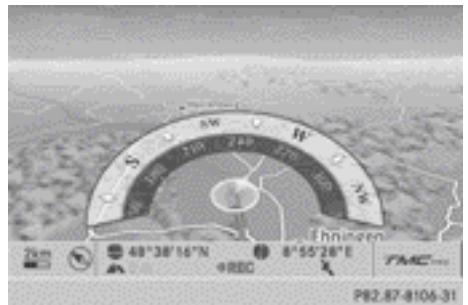
Compass view on the map



- ▶ **To show the menu:** press the COMAND controller.
- ▶ Select **Navi** in the main function bar by sliding and turning the COMAND controller and press to confirm.





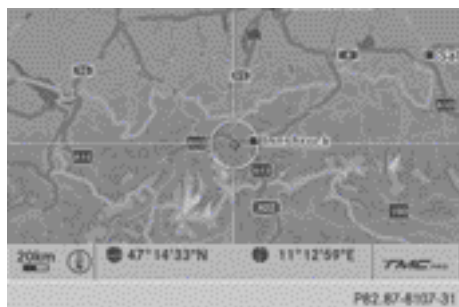

- ▶ Select **Map settings** and press  to confirm.
The Map settings menu appears.
- ▶ Select **Compass on map** and press  to confirm.
A menu appears.
- ▶ Select **Never**, **When off-road** or **When route guidance inactive** and press  to confirm.
The selected setting is accepted.

Switching additional information on/off



Example: topographic map

Switching the topographic map on/off

- ▶ **To show the menu:** press  the COMAND controller.
- ▶ Select **Navi** in the main function bar by sliding  and turning  the COMAND controller and press  to confirm.
- ▶ Select **Map settings** and press  to confirm.
The Map settings menu appears.
- ▶ Select **Topographic map** and press  to confirm.
Depending on the previous status, switch the option on or off .

The topographic map uses different colours to depict elevation. The colour key generally reflects the topography's dominant vegetation or the ground's perceived colour when seen from the air, for example:

- green (grass) for lowland
- yellow, brown (woodland) for hills
- grey (stone) and white (snow) for mountains.

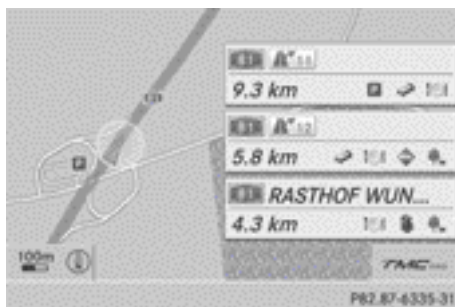





Example: motorway information

Switching motorway information on/off

When driving on the motorway, you can see the following information on the right of the display:

- the nearest filling stations
- the nearest rest areas, etc.
- and their distance from the current vehicle position

The entries show the number of the motorway and the motorway exits as well as their distance from the current vehicle position.

- ▶ **To switch on navigation mode:** press the **NAVI** function button.
- ▶ **To show the menu:** press  the COMAND controller.
- ▶ Select **Navi** in the main function bar by sliding  and turning  the COMAND controller and press  to confirm.
- ▶ Select **Map settings** and press  to confirm.
The Map settings menu appears.



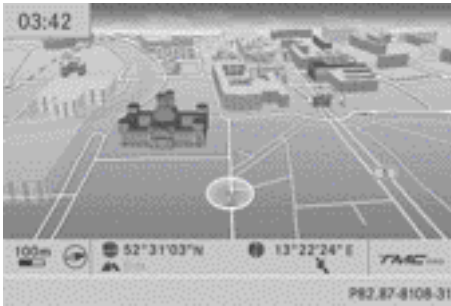



- ▶ Select **Motorway information** and press  to confirm.
Depending on the previous status, switch the option on or off .



Example: city model

Switching town view on/off

When the city model is switched on, the map shows buildings as 3D models.

- ▶ **To show the menu:** press  the COMAND controller.
- ▶ Select **Navi** in the main function bar by sliding  and turning  the COMAND controller and press  to confirm.
- ▶ Select **Map settings** and press  to confirm.
The Map settings menu appears.
- ▶ Select **City (3D)** and press  to confirm.
Depending on the previous status, switch the option on or off .

i The city model is only shown in the bird's-eye view and 3D maps.

It is available for the 50 m and 100 m map scales.







The data required for displaying buildings is not available for all towns.



Example: intersecting roads on city routes/motorways

Showing/hiding intersecting roads

If route guidance is not active, intersecting roads can be displayed at the upper edge of the display.

- ▶ **To show the menu:** press  the COMAND controller.
- ▶ Select **Navi** in the main function bar by sliding  and turning  the COMAND controller and press  to confirm.
- ▶ Select **Map settings** and press  to confirm.
The Map settings menu appears.
- ▶ Select **Next intersecting street** and press  to confirm.
Depending on the previous status, switch the option on or off .

Speed Limit Assist

Information and requirements

If COMAND Online supports Speed Limit Assist and the function is switched on in COMAND Online, it can show the permissible speed limit in the COMAND display.

i The display appears if Speed Limit Assist detects traffic signs stating the maximum permissible speed.

Speed Limit Assist detects these traffic signs using a camera; see the separate vehicle Owner's Manual.

Restricted speed limits may also be displayed.

Restrictions include:

- **when wet** – applies only if the road is wet
- **when icy** – applies only if the road is slippery (due to cold)
- **in fog** – applies only in foggy weather
- **temporary** – applies only at certain times
- **Limited** – COMAND Online cannot identify the type of restriction

If the corresponding data is available, you see the information at the bottom left of the COMAND display. You might see "120" or "80 when wet", for example, directly above the map scale indicator.



The displays also appear in the multifunction display in the Assistance menu; see the separate vehicle Owner's Manual.

i The speed limits displayed may be incorrect if:

- the data is outdated.
- the camera has failed to identify a traffic sign correctly.

Switching Speed Limit Assist on/off

► **To show the menu:** press  the COMAND controller.

► Select **Navi** in the main function bar by sliding  and turning  the COMAND controller and press  to confirm.

► Select **Speed Limit Assist** and press  to confirm.

Depending on the previous status, switch the option on or off .

Additional settings

Avoiding an area

General notes

COMAND Online enables you to avoid areas you do not wish to drive through.

If you activate or deactivate a route block while route guidance is active, COMAND Online will calculate a new route. If you activate or deactivate a route block while route guidance is inactive, COMAND Online will use the new setting for the next route guidance.



i Motorways within blocked areas are always included in the route calculation.

Defining an area for the first time

Calling up the area menu

► **To switch on navigation mode:** press the  function button.

► **To show the menu:** press  the COMAND controller.

► Select **Navi** in the main function bar by sliding  and turning  the COMAND controller and press  to confirm.

► Select **Avoid area** and press  to confirm.

If you have not previously blocked an area, a menu appears.

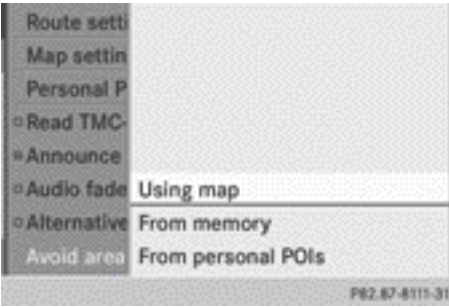

- ▶ Select **Using map**, **From memory** or **From personal POIs** and press to confirm. If you select **Using map**, the map with the crosshair appears. If you select **From memory** or **From personal POIs**, either the destination memory or the list of categories for POIs appears.
 - Destination memory (▶ page 323)
 - List of categories for personal POIs (▶ page 338)
- ▶ Select the desired destination or personal POI and press to confirm.
- ▶ When the destination address is displayed, select **Continue** and press to confirm. The map appears.



The crosshair marks the centre of the area that is to be avoided.

- ▶ **To scroll the map:** slide or or the COMAND controller.
- ▶ **To set the map scale:** as soon as you turn the COMAND controller, the scale bar

appears. Turning clockwise zooms out from the map; turning anti-clockwise zooms in.

- ▶ Turn until the desired scale is set.
- ▶ **To apply a block:** press the COMAND controller. A red square appears on the map.

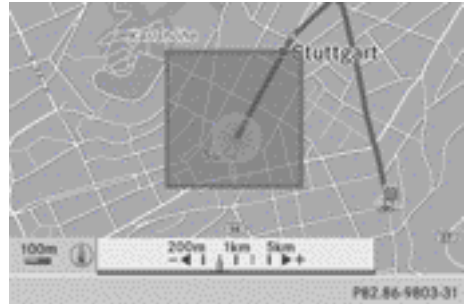

- ▶ **To adjust the size of the square:** turn the COMAND controller. The square is enlarged or reduced.
- ▶ **To confirm the settings:** press . The list appears. The previously selected area to be avoided has been added and activated.

You can define additional areas that you would like to avoid (▶ page 371).

Defining further areas

Calling up the list of areas

- ▶ **To switch on navigation mode:** press the **NAVI** function button.
- ▶ **To show the menu:** press the COMAND controller.
- ▶ Select **Navi** in the main function bar by sliding and turning the COMAND controller and press to confirm.
- ▶ Select **Avoid area** and press to confirm. If you have already selected one or more areas to avoid, a list of areas appears.



Example: list of areas

i Available positions in the list are named **Empty** and are shown in grey.

- ▶ Select **Avoid new area** by turning **Ⓢ** the COMAND controller and press **Ⓜ** to confirm. A menu appears.

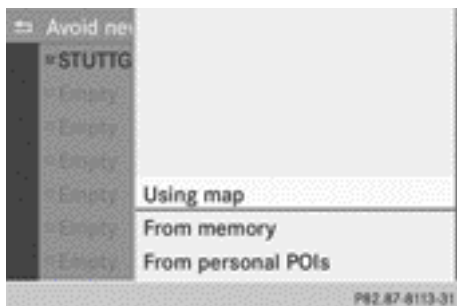

- ▶ Select **Using map**, **From memory** or **From personal POIs** and press **Ⓜ** to confirm. If you select **Using map**, the map with the crosshair appears.

If you select **From memory** or **From personal POIs**, either the destination memory or the list of categories for POIs appears.

- Destination memory (▶ page 323)
- List of categories for personal POIs (▶ page 338)
- ▶ Select the desired destination or personal POI and press **Ⓜ** to confirm.
- ▶ When the destination address is displayed, select **Continue** and press **Ⓜ** to confirm. The map appears.

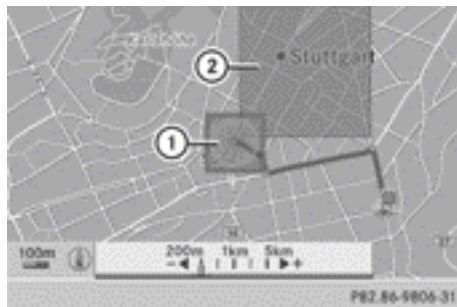

- ① New area to be avoided, the size of which can still be adjusted
- ② Area currently being avoided

- ▶ **To avoid a new area:** call up the area menu again (▶ page 370). The illustration shows an example with two areas that are to be avoided.

Switching an avoided area on/off

- ▶ Call up the area list (▶ page 371).
- ▶ Select an entry in the list by turning **Ⓢ** the COMAND controller and press **Ⓜ** to confirm. The avoided area is switched on or off depending on the previous status.

Displaying and changing an avoided area

- ▶ Call up the area list (▶ page 371).
- ▶ Select an entry in the list by turning **Ⓢ** the COMAND controller.
- ▶ Slide **Ⓢ** the COMAND controller and press **Ⓜ** to confirm.
- ▶ Select **Display / Change** and press **Ⓜ** to confirm. The area to be avoided is indicated on the map.
- ▶ **To change the location of the area:** slide **Ⓢ**, **Ⓢ** or **Ⓢ** the COMAND controller. The area is moved on the map.
- ▶ **To adjust the size of the area:** turn **Ⓢ** the COMAND controller. The area is enlarged or reduced.

- ▶ **To confirm the change:** press the COMAND controller. The list appears and the change is entered.

Deleting a set area

- ▶ Call up the area list (> page 371).
- ▶ Select an entry in the list by turning the COMAND controller.
- ▶ Slide to the COMAND controller and press to confirm.
- ▶ Select **Delete** and press to confirm. A query appears asking whether the entry should be deleted.
- ▶ Select **Yes** or **No**. If you select **Yes**, the entry is deleted. If you select **No**, the process will be cancelled.

Compass function

In the compass view, you can see the current direction of travel, the current height above sea level and the co-ordinates of the vehicle position, for example.

- ▶ **To switch on navigation mode:** press the **NAVI** function button.
- ▶ **To show the menu:** press the COMAND controller.
- ▶ Select **Position** in the navigation system menu bar by sliding and turning the COMAND controller and press to confirm.
- ▶ Select **Compass** and press to confirm.

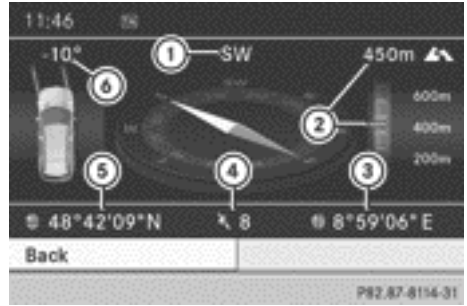





Example: compass

- ① Current direction of travel
 - ② Current elevation above average sea level, rounded
 - ③ Current vehicle position: longitude coordinates
 - ④ Number of GPS satellites currently being used
 - ⑤ Current vehicle position: latitude coordinates
 - ⑥ Currently set steering angle of the front wheels
- i** To display current elevation ②, the system must be able to receive at least four satellites. Steering angle ⑥ can be a maximum of 35° in both directions.
- ▶ **To exit the display:** confirm **Back** by pressing or press the back button.

Showing the map data version



- ▶ **To show the map data menu:** press the COMAND controller.

▶ Select **Navi** in the main function bar by sliding   and turning   the COMAND controller and press  to confirm.

▶ Select **Map version** and press  to confirm.

The map data version number is shown. Information about new versions of the digital map can be obtained from a Mercedes-Benz Service Centre.

Updating the digital map

Introduction

The digital maps generated by the map software become outdated in the same way as conventional road maps. Optimal route guidance can only be provided by the navigation system in conjunction with the most up-to-date map software.

Information about new versions of the digital map can be obtained from a Mercedes-Benz Service Centre. You can have the digital map updated there with a DVD, or you can update it yourself.

In some countries, it is possible to update the map data for COMAND Online free of charge for a period of 3 years. Information on the availability of this service for your vehicle can be obtained from your Mercedes-Benz Service Centre. If the free update is not available in your country, please read the "Updating process" section.

Entitlement to the free update

For the first three years after your vehicle is registered, you are entitled to all available updates to the map software for COMAND Online. They are usually installed during a regular vehicle service. After this period, you can purchase further updates from your Mercedes-Benz Service Centre.

The free updates relate to the vehicle and not to an individual. If there is a change of ownership within 3 years of first registration, the new owner is entitled to the map software updates.

Availability of free updates

Enter your e-mail address at <http://www.mercedes-benz-accessories.com/comand-infomail>. You will receive a one-off e-mail containing information on how to update the map software. Go to <http://www.mercedes-benz-accessories.com/navigation-updates> also, to find out if map software updates for your vehicle are available at your Mercedes-Benz partner.

Updating at the Mercedes-Benz Service Centre

If an update for your map software is available, you will receive it free of charge at your Mercedes-Benz Service Centre during your vehicle's annual service. You can arrange a separate appointment for this at your Mercedes-Benz Service Centre on request.

The update can only be performed:

- at a Mercedes-Benz Service Centre
- for European navigation data

The map software is not provided on DVD.

Important safety notes

WARNING





Never run the engine in an enclosed space. The exhaust fumes contain poisonous carbon monoxide. Inhaling exhaust fumes is hazardous to your health and can lead to loss of consciousness and death.

Changing the update process yourself

 The update process may take some time (over an hour), depending on the size of the digital map. During this time, you will only be able to switch on radio mode and to accept incoming calls. The update will be completed more quickly if the vehicle is stationary.

If you start the update with the engine switched off and the starter battery has insufficient power, COMAND Online may automatically switch off. This preserves the battery. If this occurs, restart the update with the engine running.

- ▶ Insert the DVD:
 - in the single DVD drive (▷ page 460)
 - in the DVD changer (▷ page 460)
 COMAND Online checks whether the digital map on the DVD is compatible with the navigation system and system software. A prompt then appears asking if you want to install the database. Versions of the database currently installed and the database that is to be installed are displayed.
 - ▶ Select **Yes** or **No** and press  to confirm. After selecting **Yes**, an activation code must be entered when installing a database for the first time. You will receive the activation code when you buy the navigation DVD.

If you select **No**, the process will be cancelled.
 - ▶ Enter the activation code. After entering the activation code correctly, COMAND Online starts updating the digital map. Once the update is finished, you will see a message.
 - ▶ **To confirm the message:** press  the COMAND controller.
 - ▶ Take the DVD out of the slot. While the update is running, you will see a message to this effect and a progress bar. The navigation system is not operational until the update is complete.
 -  You cannot eject the DVD during the update. If you switch off COMAND Online during the update, the update is interrupted. It then continues from where it was interrupted when the system is restarted.
- COMAND Online may prompt you to change the DVD during the update.
- ▶ Press the  (for DVD changer) or  (for single DVD drive) load/eject button.
 - ▶ Take the DVD out of the slot.
- ▶ Insert the requested DVD. Once the update has been successfully completed, you will see a message to this effect.
 - ▶ **To confirm the message:** press  the COMAND controller.
 - ▶ Take the DVD out of the slot. The update is complete.

If the update is not successfully completed, you will see a message that the map update is not possible.
 - ▶ **To confirm the message:** press  the COMAND controller.
 - ▶ Take the DVD out of the slot.

Problems with the navigation system

Problem	Possible causes/consequences and ► Solutions
COMAND Online is unable to continue route guidance after the journey has been interrupted.	<p>Route guidance is cancelled if you interrupt the journey for more than two hours.</p> <p>"Interrupting the journey" refers to stopping the vehicle.</p> <p>"Continuing route guidance" refers to switching COMAND Online back on and driving on.</p> <p>► Continue route guidance (► page 348).</p>

Problem	Possible causes/consequences and ► Solutions
COMAND Online is unable to determine the vehicle's position.	<p>COMAND Online has to redetermine the position of the vehicle if the vehicle has been transported.</p> <p>Examples:</p> <ul style="list-style-type: none"> • after transporting the vehicle by ferry • after transporting the vehicle by motorail • after the vehicle has been towed <p>► Start the vehicle and pull away.</p> <p>COMAND Online determines the vehicle's position. Depending on the driving situation, this may take some time.</p> <p>Route guidance may be restricted during the determination of the vehicle's position.</p> <p>When positioning is complete, route guidance is resumed with navigation announcements and route guidance displays.</p>

Problem	Possible causes/consequences and ► Solutions
<p>The Navigation unavailable message appears.</p>	<p>COMAND Online has an integrated hard drive on which the digital map is stored.</p> <p>To protect the integrated hard drive against damage, COMAND Online deactivates it at very high and low temperatures. The navigation system will then be temporarily unavailable.</p> <ul style="list-style-type: none"> ► Let the vehicle and COMAND Online cool down. ► To hide the message: switch COMAND Online off and then on again.
	<p>If an area of the hard disk has a fault, COMAND Online can no longer access the map data in this area. This may occur when calculating a route, for example.</p> <ul style="list-style-type: none"> ► To hide the message: switch COMAND Online off and then on again. <p>The navigation system will be operational again until it has to access the faulty area of the hard drive once more. The message will then reappear.</p> <ul style="list-style-type: none"> ► Consult a Mercedes-Benz Service Centre.

Problem	Possible causes/consequences and ► Solutions
<p>You see a message informing you that the DVD containing the digital map is incompatible with the system software.</p>	<p>The DVD containing the digital map cannot be used for the update.</p> <ul style="list-style-type: none"> ► To confirm the message: press  the COMAND controller. ► Eject the DVD. ► Have the system database checked at a Mercedes-Benz Service Centre.

Problem	Possible causes/consequences and ► Solutions
<p>The map software update has failed.</p>	<p>The DVD is dirty.</p> <ul style="list-style-type: none"> ► Clean the DVD. ► Restart the update.
	<p>The DVD is scratched.</p> <ul style="list-style-type: none"> ► Consult a Mercedes-Benz Service Centre.

Problem	Possible causes/consequences and ► Solutions
	<p>There is overheating due to excessive temperatures in the vehicle interior.</p> <ul style="list-style-type: none"> ► Wait until the vehicle interior has cooled down. ► Restart the update.
	<p>COMAND Online's integrated hard disk is defective.</p> <ul style="list-style-type: none"> ► Consult a Mercedes-Benz Service Centre.

Problem	Possible causes/consequences and ► Solutions
COMAND Online asks for an activation code during the map update.	<p>The digital map is secured with an activation code.</p> <ul style="list-style-type: none"> ► Consult a Mercedes-Benz Service Centre.

Telephone

Features of your COMAND Online

This Supplement describes all the standard and optional equipment for your COMAND Online system, as available at the time of going to print. Country-specific differences are possible. Please note that your COMAND Online system may not be equipped with all the features described.

General notes

Introduction

COMAND Online allows you to use three different modes of telephony:

- telephony via the Bluetooth® interface (standard equipment and optional equipment in conjunction with fittings for convenience telephony and mobile phone brackets)
- convenience telephony (only in conjunction with fittings for convenience telephony and mobile phone brackets)
- permanently installed/SAP telephony (only in conjunction with fittings for convenience

telephony and **data-enabled** MB SAP module)

In **telephony via Bluetooth® interface** mode, the mobile phone is connected directly to COMAND Online via Bluetooth®.

Enhancing this operating mode with the optional convenience telephony fittings and the mobile phone bracket allows you to:

- connect the mobile phone to the exterior aerial on the vehicle
- charge the mobile phone

In **convenience telephony** mode, the mobile phone is connected to the mobile phone bracket.

Depending on the mobile phone bracket fitted, the connection is established:

- by inserting the mobile phone into the mobile phone bracket
- via a Bluetooth® connection between the mobile phone and the mobile phone bracket.

In the **permanently installed/SAP telephony** mode, the optional **data-enabled** MB SAP module is inserted into the convenience telephony fitting in the armrest.

- ❗ SAP telephony is described in separate operating instructions.

When connecting Bluetooth®-capable mobile phones with PBAP (**P**hone **B**ook **A**ccess **P**rofile) or a convenience telephone, the contacts are automatically downloaded to COMAND Online.

Basic telephony, in conjunction with a Bluetooth®-capable mobile phone, enables you to make calls via the Bluetooth interface. With a suitable mobile phone, you can use the hands-free system and receive vCards via the Bluetooth® interface.

If your vehicle is equipped with convenience telephony, you can obtain mobile phone brackets for specific mobile phones at your Mercedes-Benz Service Centre and have them installed in the armrest.

The mobile phone battery is charged in the bracket and a connection is made to the vehicle's exterior aerial.

Using a suitable mobile phone, the hands-free system is available with convenience telephony.

You can use the text message function (receive and read) under the following conditions:

- the mobile phone bracket and the mobile phone support the function (convenience telephony).
- the mobile phone supports the MAP Bluetooth® profile (**M**essage **A**ccess **P**rofile), (basic telephony).

- ❗ Even if your vehicle is equipped with convenience telephony, you can connect a Bluetooth®-capable mobile phone with COMAND Online via the Bluetooth® interface.

Further information on the following topics can be obtained from your Mercedes-Benz Service Centre or on the Internet at <http://www.mercedes-benz.com/connect>

- suitable mobile phones
- available mobile phone brackets

- connecting Bluetooth®-capable mobile phones to COMAND Online
- overview of the functions of the three operating modes

Safety notes

WARNING

You must observe the legal requirements for the country in which you are currently driving when operating mobile communications equipment in the vehicle.

If it is permitted to operate communications equipment while the vehicle is in motion, you may only operate such equipment when road and traffic conditions permit. You may otherwise be distracted from the traffic conditions, cause an accident and injure yourself and others.

Two-way radios or fax machines without low-reflection exterior aerials may interfere with the vehicle electronics and thereby compromise the operational safety of the vehicle and your safety. Therefore, only use these if they are properly connected to a separate, low-reflection exterior aerial.

WARNING

Excessive electromagnetic radiation may constitute a health hazard to yourself and others. There is scientific discussion surrounding the possible health risks posed by electromagnetic fields. You can reduce this risk by using an exterior aerial.

Therefore, only use mobile communication equipment if it is connected to the exterior aerial of the vehicle.









Disconnecting a call while the vehicle is in motion

A call may be disconnected if:

- there is insufficient GSM network coverage in certain areas.
- you move from one GSM or UMTS transmitter/receiver area (GSM/UMTS cell) into another and no channels are free.
- you use a SIM card that is not compatible with the network available.
- you are using a mobile phone with "Twin-card" and the mobile phone with the second SIM card is logged into the network at the same time.

Operating options

You can operate the telephone by:

- using the COMAND controller:
 - turn 
 - slide  or 
 - press 
- using the  or  button and using the telephone keypad on COMAND Online
- using the  or  button on the multifunction steering wheel
- using LINGUATRONIC (see the separate LINGUATRONIC operating instructions)

Unless stated otherwise, the descriptions and illustrations in this section refer to COMAND Online.

Function restrictions

You will not be able to use the telephone, will no longer be able to use the telephone, or you may have to wait before using it in the following situations:

- if the mobile phone is switched off
- if the "Bluetooth®" function is switched off in COMAND Online

- if the Bluetooth® function is switched off on the mobile phone while you are using Bluetooth® interface telephony
- if the mobile phone is not logged into a mobile phone network

i The telephone automatically tries to log on to a network. If no network is available, you may not be able to make a "999" or "112" emergency call. If you attempt to make an outgoing call, the **No service** message will appear for a short while.

If you switch COMAND Online off during a call in hands-free mode, the call will be terminated. You can prevent this as follows:

Telephony via the Bluetooth® interface

- ▶ Switch the mobile phone to private mode before switching off COMAND Online (see the mobile phone operating instructions).

Convenience telephony

- ▶ Before switching off COMAND Online, remove the mobile phone from the bracket and, if necessary, switch the mobile phone to private mode (see the mobile phone operating instructions).

"999" or "112" emergency call

The following conditions must be fulfilled in order to make a **999** or **112** emergency call:

- the mobile phone must be switched on.
- a network must be available.
- a valid and operational SIM card must be inserted in the mobile phone.
- the PIN must have been entered.

If you cannot make an emergency call, you must arrange rescue measures yourself.

i The **999** or **112** emergency call number is a public service. Any misuse is punishable by law.

Telephony via the Bluetooth® interface

Conditions

For telephony via COMAND Online's Bluetooth® interface, a Bluetooth®-capable mobile phone is required.

On COMAND Online

- ▶ Activate the Bluetooth® function in COMAND Online (▷ page 306).

On the mobile phone

- ▶ Switch on the mobile phone and enter the PIN when prompted to do so (see the mobile phone operating instructions).
- ▶ Activate Bluetooth® functions and, where necessary, Bluetooth® visibility on the mobile phone (see the mobile phone operating instructions).

The battery of the mobile phone should always be kept sufficiently charged in order to prevent malfunctions.

In preparation for telephoning via the Bluetooth® interface, you should check the following items on your mobile phone (see the mobile phone operating instructions):

- Hands-Free Profile
The mobile phone must support Hands-Free Profile 1.0 or above.
- Bluetooth® visibility
On certain mobile phones, the device itself must be made "visible" to other devices, as well as activating the Bluetooth® function (see the mobile phone operating instructions).
This visibility is for restricted periods of time on some mobile phones.
- Bluetooth® device name
Every Bluetooth® device has a Bluetooth® device name. This device name is freely definable, but can be identical for all devices from the same manufacturer. It is therefore recommended that you change this name so that you can easily recognise

your mobile phone (see the mobile phone operating instructions).

- i** Not all mobile phones available on the market are equally suitable. Further information on suitable mobile phones and mobile phone brackets can be obtained at your Mercedes-Benz Service Centre or on the Internet at <http://www.mercedes-benz.com/connect>.
- i** Some displays (e.g. the signal strength) depend on the supported version of the Hands-Free Profile.

Connecting a mobile phone

General information

Before using your mobile phone with COMAND Online for the first time, you will need to:

- search for it (▷ page 382) and then
- authorise (register) it (▷ page 383).

Device-specific information on authorising and connecting Bluetooth®-capable mobile phones can be found on the Internet at <http://www.mercedes-benz.com/connect>.

When you authorise a new mobile phone, it is connected automatically.

You can authorise up to 15 mobile phones. If the mobile phone supports PBAP (**Phone Book Access Profile**) and MAP (**Message Access Profile**), the following contacts and messages are downloaded into COMAND Online when connecting:

- the phone book
- the call lists
- text messages (SMS)

Further information on the conditions for connecting (▷ page 381).

Searching for a mobile phone

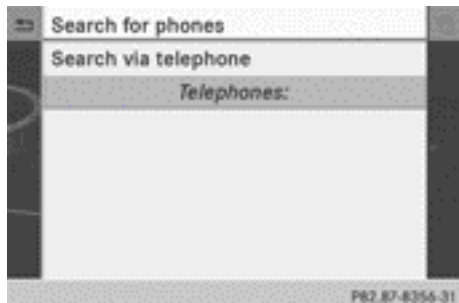

Empty Bluetooth® telephones list

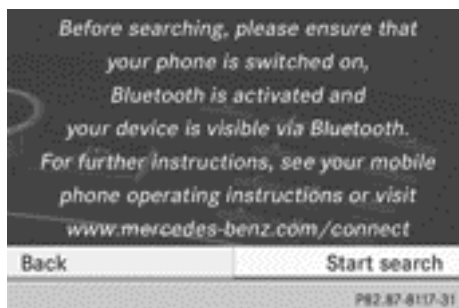

Conditions for searching

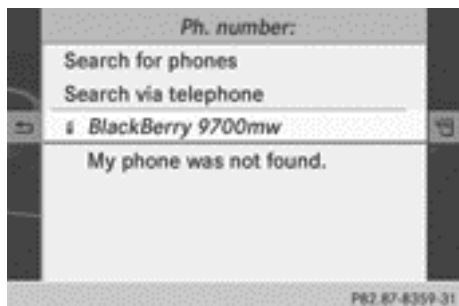

Bluetooth® telephone list after a completed search

- ▶ Press the **TEL** function button on COMAND Online.
- ▶ Select **Connect device** in the telephone basic menu by sliding **⊙↓** and turning **⊙↻** the COMAND controller and press **⊙** to confirm.

- ▶ Select **Search for phones** and press the **⊙** button to confirm.

A message appears.





- ▶ Select **Start search** and press the **⊙** button to confirm.

The **Searching for Bluetooth phones...** message appears. COMAND Online looks for Bluetooth® telephones within range and adds them to the Bluetooth® telephones list.

If a new phone is found, it appears in the list with the  symbol.

The duration of the search depends on the number of Bluetooth® telephones within range and their characteristics.

Symbols in the Bluetooth® phone list

Symbol	Explanation
	New mobile phone in range, but not yet authorised
	Authorised mobile phone
	Currently connected mobile phone
	Mobile phone in range and authorised
	Mobile phone not in range, but already authorised

The Bluetooth® telephones list shows all mobile phones within range and all previously authorised mobile phones, whether or not they are in range.

- i** Mobile phones that are connected to the optional data-enabled MB SAP module are shown in a separate phone list. These can be called up using the **MB SAP module** entry. See the data-enabled MB SAP module's separate operating instructions.

- i** If the Bluetooth® telephones list is already full, you will be requested to de-authorise a mobile phone (▶ page 385). If COMAND

Online does not find your mobile phone, external authorisation may be necessary (▷ page 384).

- i When you call up the phone list again, de-authorised devices will be removed from the list. In this case, start a new search to update the Bluetooth® telephone list.

Authorising (registering) a mobile phone



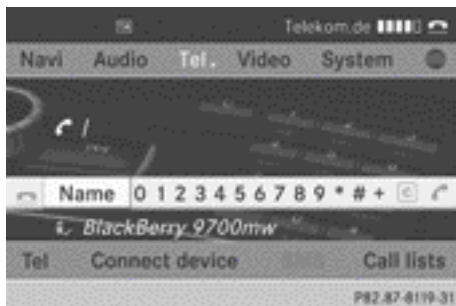

Passkey entry



Telephone basic menu

Option 1: using the passkey (access number)

- ▶ Select the mobile phone with the  symbol from the Bluetooth® telephones list by turning  the COMAND controller and press  to confirm.



The input menu for the passkey appears.

The passkey is any one to sixteen-digit number combination which you can choose yourself. You must enter the same number combination in COMAND Online and in the Bluetooth®-capable mobile phone (see the mobile phone operating instructions).

- i Some mobile phones require a passkey with four or more digits.
- i If you want to re-authorise a mobile phone following de-authorisation, you can select a different passkey.
- i Mercedes-Benz recommends de-authorisation in COMAND Online and on the mobile phone(▷ page 385). Subsequent authorisation may otherwise fail.

▶ **To enter a passkey in COMAND Online:** press the number keys in turn.

or

▶ Select the digits in the digit bar one by one by turning  the COMAND controller and pressing  to confirm.

 is highlighted after the first number has been entered.

▶ In both cases, select  and press  to confirm.

▶ **To enter the passkey on the mobile phone:** if the Bluetooth® connection is successful, you will be requested to enter the passkey (access code, passcode; see the mobile phone operating instructions).

▶ Enter the same passkey in the mobile phone as the one already entered in COMAND Online.

The [Connecting Bluetooth profiles...](#) message appears.

The [Authorisation successful](#) message appears once authorisation is completed.

The mobile phone is authorised and connected to COMAND Online. You can now make phone calls using the COMAND Online hands-free system.

- i After entering the passkey, you may also need to enter a confirmation in your mobile phone in order to make calls. Please check your mobile phone display. On some mobile phones, this confirmation can be saved. In this case, you do not need to enter it again.

If the COMAND Online display shows the **Authorisation failed** message, you may have exceeded the prescribed time period. Repeat the procedure.

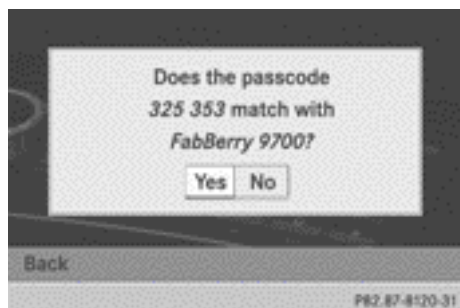

Option 2: using Secure Simple Pairing

To connect via Secure Simple Pairing, the mobile phone (or Bluetooth® audio equipment) must support Bluetooth® Version 2.1. COMAND Online creates a six-digit code, which is displayed on both devices that are to be connected.

- ▶ If the code is the same on both devices, confirm **Yes** by pressing . If you select **Yes**, authorisation is continued and the mobile phone is connected. If you select **No**, the process will be cancelled.
- ▶ Confirm the message on the mobile phone.





External authorisation



If COMAND Online does not detect your mobile phone, this may be due to particular security settings on your mobile phone. In this case, you can test if your mobile phone can

find COMAND Online. The Bluetooth® device name of COMAND Online is "**MB Bluetooth**".

Please note the following: some mobile phones require that you establish the connection to COMAND Online again once you have entered the passkey (see the mobile phone operating instructions). The mobile phone cannot otherwise be authorised.

- ▶ Press the **TEL** function button on COMAND Online.
- ▶ Select **Connect device** in the telephone basic menu by sliding  and turning  the COMAND controller and press  to confirm. The Bluetooth® telephones list appears.
- ▶ Select **Search via telephone** and press the  button to confirm. The message on the left appears.
- ▶ Start the Bluetooth® search on the mobile phone; see the mobile phone operating instructions.
- ▶ Select COMAND Online (**MB Bluetooth**) on the mobile phone.
- ▶ **Option 1:** when requested to do so, enter the passkey first on the mobile phone and then in COMAND Online.
- ▶ **Option 2:** confirm the displayed codes on the mobile phone and in COMAND Online (Secure Simple Pairing).

With both options, you see the prompt **Do you want to authorise <device name> ?** on the COMAND display.

- ▶ If you select **Yes**, the mobile phone will be authorised. The messages **Waiting for <name of B-tooth dev.> to be connected...** and **Connecting Bluetooth profiles...** are displayed. If the connection is successful, you see the telephone basic menu and the connected mobile phone is entered.

If you select **No**, the process will be cancelled.



Reconnecting automatically

COMAND Online always searches for the last connected mobile phone.

If no connection can be made to the most recently connected mobile phone, the system searches for the mobile phone that was connected before that one.

Switching between mobile phones

If you have authorised more than one mobile phone, you can switch between the individual phones.

- ▶ Select the mobile phone in the Bluetooth® telephones list by turning  the COMAND controller and press  to confirm.





The selected mobile phone is searched for and connected if it is within Bluetooth® range and if Bluetooth® is activated.



Only one mobile phone can be connected at any one time. The currently connected mobile phone is indicated by the • dot in the Bluetooth® telephones list.

- i** You can only switch to another authorised mobile phone if you are not currently making a call.

De-authorising (de-registering) a mobile phone

Mercedes-Benz recommends de-authorisation in COMAND Online and on the mobile phone. Subsequent authorisation may otherwise fail.

- ▶ Press the  function button on COMAND Online.
- ▶ Select **Connect device** in the telephone basic menu by sliding  and turning  the COMAND controller and press  to confirm.
The Bluetooth® telephones list appears (▷ page 382).
- ▶ Select the desired mobile phone in the Bluetooth® telephones list.









- ▶ Select the list symbol to the right of the entry by sliding  the COMAND controller and press  to confirm.
- ▶ Select **De-authorise** and press  to confirm.
A prompt appears, asking whether you really wish to de-authorise this device.
- ▶ Select **Yes** or **No**.

If you select **Yes**, the device will be deleted from the Bluetooth® telephones list.

If you select **No**, the process will be cancelled.

- i** Before re-authorising the mobile phone, you should also delete the device name **MB Bluetooth** from your mobile phone's Bluetooth® list.

Displaying connection details

- ▶ Press the  function button on COMAND Online.
- ▶ Select **Connect device** in the telephone basic menu by sliding  and turning  the COMAND controller and press  to confirm.
The Bluetooth® telephones list appears.
- ▶ Select the desired mobile phone in the Bluetooth® telephones list.
- ▶ Select the list symbol to the right of the entry by sliding  the COMAND controller and press  to confirm.
- ▶ Select **Details** and press  to confirm.
The following information concerning the selected mobile phone is shown:
 - Bluetooth® name
 - Bluetooth® address
 - availability status (shown after a new search)
 - authorisation status
- ▶ **To close the detailed view:** turn  or slide  the COMAND controller.

Telephone basic menu (Bluetooth® interface)

Basic menu display



Telephone basic menu (Bluetooth® interface)

- ① Network provider's name (depends on the connected phone)
- ② Signal strength of mobile phone network
- ③ Receiver icon or
- ④ To display call lists
- ⑤ Character bar
- ⑥ Bluetooth® name of the currently connected mobile phone
- ⑦ To display the COMAND phone book

► Press the **TEL** function button.

The telephone basic menu appears when the connected mobile phone is ready for use.

- ❗ Displays ① and ② are shown, depending on the mobile phone connected.

Bars ② show the current signal strength of the mobile phone network. If all bars are filled, you have optimum reception.

If there are no bars, there is very poor reception or none at all.

Receiver icon shows whether a call is active/being connected or not .

Displaying text messages in the telephone basic menu

The **SMS** menu item is only available if the Bluetooth® phone supports the MAP Bluetooth® profile (**M**essage **A**ccess **P**rofile). The

downloading of text messages from the Bluetooth® phone must have been completed. The menu item is otherwise greyed out. Further information on text messages (► page 403).

If you have an unread text message, the mail symbol is displayed. The symbol disappears once you have read the text message. The mail symbol is displayed as soon as the text message memory is full. The symbol disappears once you delete at least one text message.

Convenience telephony

Connecting a mobile phone

Establishing a connection

For convenience telephony with COMAND Online, a mobile phone bracket and a suitable mobile phone are required.

- ❗ Most mobile phones are connected via Bluetooth® using the mobile phone bracket. In this case you can also use convenience telephony when the mobile phone is not in the mobile phone bracket. However, you then have no charging and antenna function.

Further information on suitable mobile phones and on connecting convenience phones to COMAND Online can be obtained:

- at your Mercedes-Benz Service Centre
- on the Internet at <http://www.mercedes-benz.com/connect>
- Insert the bracket into the fixture in the armrest; see the vehicle Owner's Manual.
- Insert the mobile phone into the bracket; see the vehicle Owner's Manual.



Example

- ① To engage the mobile phone
 - ② Connector contact
 - ③ Mobile phone bracket
- ▶ Switch on the mobile phone; see the mobile phone operating instructions.
 - ▶ If Bluetooth® interface telephony is active: press the **TEL** function button.
 - ▶ Select **Telephone** in the telephone basic menu by turning **⏻** the COMAND controller and press **⏻** to confirm.
 - ▶ Select **Bluetooth telephones** and press **⏻** to confirm.
 - ▶ Select **Convenience phone** and press **⏻** to confirm.
- You may be requested to enter the PIN via COMAND Online.
- i** Some mobile phones can switch on automatically when inserted into the bracket.

PIN entry



- ① PIN entry line
- ② To confirm the pin (available if entered)
- ③ Character bar

You can enter the PIN using either the character bar or the number keys.

If your vehicle is equipped with LINGUATRONIC (see the separate operating instructions), you can also enter the PIN using voice commands.

- ▶ **To enter the PIN using the character bar:** turn **⏻** the COMAND controller to select digits in character bar ③ and press **⏻** to confirm.
 - ▶ Select symbol ② in character bar ③ and press **⏻** to confirm or press the **☎** button.
 - ▶ **To enter the PIN using the number keys:** enter numbers with the number keys.
 - Once you have entered the first digit, symbol ② is highlighted in the character bar.
 - ▶ Confirm symbol ② by pressing **⏻** the COMAND controller or press the **☎** button.
- In both cases, COMAND Online checks the PIN. If the PIN is entered correctly, the telephone basic menu appears.

Information on deleting (▷ page 300)

- i** Even if you have entered an incorrect PIN twice via COMAND Online, you will not see a warning informing you that you only have one more attempt. If you enter the PIN



incorrectly three times, you must unlock the SIM card using the mobile phone; see the mobile phone operating instructions.

Telephone basic menu (convenience telephony)

Basic menu display





Telephone basic menu (convenience telephony)

- ① Network provider symbol
- ② Signal strength of mobile phone network

- ③ Receiver symbol  or 
- ④ To display call lists
- ⑤ Character bar
- ⑥ To connect to the convenience phone
- ⑦ To display the COMAND phone book

► Press the **TEL** function button.

If the mobile phone is ready for use and inserted in the bracket, the telephone basic menu appears.

- i** Bars ② show the current signal strength of the mobile phone network. If all bars are filled, you have optimum reception. If all bars are empty, there is very poor reception or none at all.

The receiver symbol shows whether a call is active/being connected  or not .

Displaying text messages in the telephone basic menu

If you have an unread text message, the  mail symbol is displayed. The symbol disappears once you have read the text message.

The  mail symbol is displayed if the text message memory is full. The symbol disappears once you delete at least one text message.

The **SMS** menu item is available if the convenience telephone and bracket support the text message function. The convenience telephone must have finished downloading the text messages.

The menu item is greyed out and cannot be selected if:

- you switch from the convenience telephone to phoning via the Bluetooth® interface and the Bluetooth® telephone does not support the MAP Bluetooth® profile,
- COMAND Online first downloads the text messages from the mobile phone after the mobile phone has been inserted in the bracket.

The download time depends on:

- the number of text messages (SMS) stored on the mobile phone,
- the make of the phone.

Switching on and changing telephony operating modes

Overview

If your vehicle is fitted with convenience telephony, COMAND Online starts the telephony mode depending on whether:

- a telephone module with Bluetooth® (SAP profile) is inserted
- a mobile phone bracket is inserted

Depending on which mobile phone bracket is inserted, COMAND Online starts telephony via the Bluetooth® interface.

When neither a telephone module with Bluetooth® (SAP profile) nor a mobile phone bracket is inserted, COMAND Online immediately starts telephony via the Bluetooth® interface.

Switching on with a telephone module with Bluetooth® (SAP profile) inserted

When a telephone module with Bluetooth® (SAP profile) is inserted, COMAND Online starts SAP telephony.

- ❗ When no telephone module with Bluetooth® (SAP profile) is inserted, COMAND Online checks if a mobile phone bracket is inserted and, if so, which type.
- ❗ Before using your telephone module with Bluetooth® (SAP profile) for the first time, you need to set it up so that it will be recognised by COMAND Online. See the separate operating instructions for the data-enabled telephone module with Bluetooth® (SAP profile).

If no mobile phone is connected to the data-enabled telephone module with Bluetooth®, the **Ready for SAP connectivity...** message appears. Approximately two minutes after you switch on COMAND Online, you are asked if you want to switch to Bluetooth® telephony.

If you confirm by selecting **Yes**, the **Ready for Bluetooth telephony...** message will appear. COMAND Online will search for the two mobile phones last connected via the Bluetooth® interface. If one of the two mobile phones is found, the telephone basic menu for Bluetooth® telephony (▷ page 386) appears. If neither of the mobile phones is found, the **Ready for Bluetooth telephony...** message remains in the display. You can now connect your mobile phone (▷ page 381).

If you choose **No**, the **Ready for SAP connectivity...** message reappears.

Switching on without a telephone module with Bluetooth® (SAP profile)

Starting convenience telephony

Depending on its checks as to whether and which mobile phone bracket is inserted,

COMAND Online starts convenience telephony (▷ page 386).

If a mobile phone is connected to the mobile phone bracket, the following appear:

- the PIN query (▷ page 387)
- or the basic telephone menu (▷ page 388) for convenience telephony

If no mobile phone is connected to the bracket, the following message appears: **Telephone not inserted**. Approximately two minutes after you switch on COMAND Online, you are asked if you want to switch to Bluetooth® telephony.

If you confirm by selecting **Yes**, the **Ready for Bluetooth telephony...** message appears. COMAND Online will search for the two mobile phones last connected via the Bluetooth® interface. If one of the two mobile phones is found, the telephone basic menu for Bluetooth® telephony (▷ page 386) appears. If neither of the mobile phones is found, the **Ready for Bluetooth telephony...** message remains in the display. You can now connect your mobile phone (▷ page 381).

If you choose **No**, the **Telephone not inserted** message reappears.

Starting Bluetooth® telephony

COMAND Online starts telephony via the Bluetooth® interface and searches for the last two mobile phones to have been connected via the Bluetooth® interface. If one of the two mobile phones is found, the telephone basic menu for Bluetooth® telephony (▷ page 386) appears. If neither of the mobile phones is found, the **Ready for Bluetooth telephony...** message remains in the display. You now have to connect your mobile phone (▷ page 381).

- ❗ If you do not connect another mobile phone via the phone list, the Bluetooth® connection with the mobile phone remains active until the next time COMAND Online is switched off. While the Bluetooth® con-

nection is active, only the Bluetooth® interface functions are available to you.

Switching between modes of telephony

If your vehicle is equipped with convenience telephony, you can switch between telephony modes.

You can change the mode of telephony in the Bluetooth® phone list by selecting either a Bluetooth® telephone or the convenience telephone.

- ▶ Call up the Bluetooth® telephones list (> page 382).
- ▶ Select a mobile phone by turning **⏪** the COMAND controller and press **⏩** to confirm.

i **SAP telephony:** mobile phones that are connected to the optionally available data-enabled telephone module with Bluetooth® (SAP profile) are displayed in their own telephone list. These can be called up using the **SAP telephone** menu list, thereby switching to SAP telephony. See the separate operating instructions for the data-enabled telephone module with Bluetooth® (SAP profile).

Reception and transmission volume

The information on adjusting the reception and transmission volume applies to telephony via the Bluetooth® interface and to convenience telephony.

Once the mobile phone has been authorised, you can optimise the transmission and reception volume settings. To find out about the best possible settings for your mobile phone, contact a Mercedes-Benz Service Centre or visit <http://www.mercedes-benz.com/connect>.

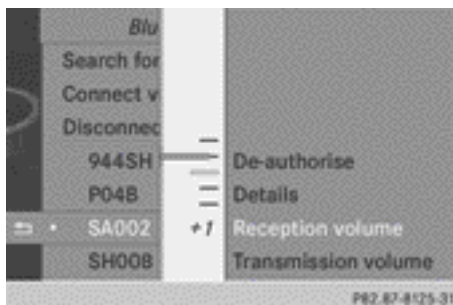

- ▶ Press the **TEL** function button.
- ▶ Select **Connect device** in the telephone basic menu by sliding **⏪** and turning **⏩** the COMAND controller and press **⏩** to confirm.
- ▶ Select an authorised mobile phone from the list by turning **⏪**.
- ▶ Select the list symbol to the right of the entry by sliding **⏪** the COMAND controller and press **⏩** to confirm.
- ▶ Select **Reception volume** or **Transmission volume** and press **⏩** to confirm.
- ▶ Select a volume setting by turning **⏪** the COMAND controller.
- ▶ **To close the setting scale:** press **⏩** or slide **⏪**.

i Incorrect settings may have an impact on the quality of calls.

Telephone operation

Incoming calls

Accepting a call

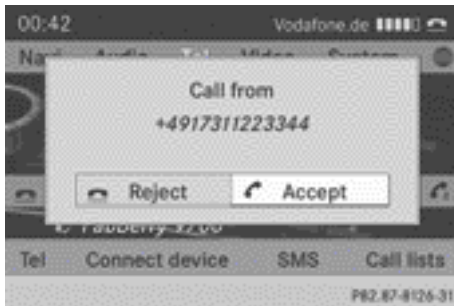

Example: incoming call

- ▶ **To accept:** confirm **Accept** by pressing .

or

- ▶ Press the  button on COMAND Online or on the multifunction steering wheel.

i You can also accept the call by voice command using LINGUATRONIC (see the separate operating instructions).

Once you have accepted the call, you can use hands-free mode.

The call volume can be adjusted (▷ page 294).

Other functions during a call (▷ page 392).



If the phone number of the caller is transferred, it appears in the display.

If an entry for the caller exists in the phone book, you will also see the name.



If the phone number is not transferred or if the "Hide data" function is active, **Unknown** is shown in the display.

i You can also accept a call as described above when another main function is switched on in COMAND. Once you have accepted the call, the display switches to telephone mode. After the call is finished, you see the display of the previous main function again.

The display does not switch to the telephone display if you:

- press the  back button next to the COMAND controller and then
- accept the call using the  button on the multifunction steering wheel

Rejecting a call

- ▶ **To reject:** select **Reject** by turning  the COMAND controller and press  to confirm.

or







- ▶ Press the  button on COMAND Online or on the multifunction steering wheel.

Making a call

Using the number keypad



- ▶ Call up the telephone basic menu:
 - convenience telephony (▷ page 388)
 - telephony via the Bluetooth® interface (▷ page 386)
- ▶ Enter the digits using the number keypad.
- ▶ **To connect the call:** press the  button on COMAND Online or on the multifunction steering wheel.

Using the telephone basic menu

- ▶ Call up the telephone basic menu:
 - convenience telephony (▷ page 388)
 - telephony via the Bluetooth® interface (▷ page 386)
 - ▶ Select the digits one by one by turning  and sliding  the COMAND controller and press  to confirm.
 - ▶ **To make a call:** select  in the character bar and press  to confirm.
- or
- ▶ Press the  button on COMAND Online or on the multifunction steering wheel.

Redialling

- ▶ Call up the telephone basic menu:
 - convenience telephony (▷ page 388)
 - telephony via the Bluetooth® interface (▷ page 386)

- ▶ Select  in the character bar and press  to confirm.

or

- ▶ If the telephone basic menu is displayed, press the  button on COMAND Online. In both cases, the calls dialled list appears. The most recently dialled number is at the top.

- ▶ **To select a call:** turn  the COMAND controller.

- ▶ **To connect the call:** press  the COMAND controller.



Redial using the multifunction steering wheel; see the separate vehicle Owner's Manual.

Using the call list or COMAND phone book

- ▶ Open a call list and select an entry (▷ page 399).

or

- ▶ Call up the COMAND phone book and select an entry (▷ page 396).

- ▶ **To make a call:** press  the COMAND controller or the  button.

Select and place a call using the multifunction steering wheel; see the separate vehicle Owner's Manual.

Using speed dial presets to make a call

The speed dial list contains stored entries from the phone book (▷ page 401).

Option 1:



- ▶ Press one of the number keys for longer than two seconds.

The telephone basic menu displays the selected entry. This initiates dialling.



Option 2:

- ▶ Call up the telephone basic menu:

- convenience telephony (▷ page 388)
- telephony via the Bluetooth® interface (▷ page 386)

- ▶ Select **Call lists** by sliding  and turning  the COMAND controller and press  to confirm.

A menu appears.

- ▶ Select **Speed dial preset list** by turning  the COMAND controller and press  to confirm.

The speed dial list appears.

- ▶ Select the preset and press  to confirm. The telephone basic menu displays the selected entry. This initiates dialling.

Functions available during a call

Overview



Telephone operation with a single call

- ① Person you are calling
- ② Symbol for active telephone connection
- ③ To switch the hands-free microphone off/on (▷ page 392)
- ④ To send DTMF tones (not possible with all mobile phones) (▷ page 393)
- ⑤ To end the call

Switching the hands-free microphone on/off

This function is also available during an active phone call.

- ▶ Call up the telephone basic menu:

- convenience telephony (▷ page 388)
- telephony via the Bluetooth® interface (▷ page 386)

▶ **To switch off:** select **Mike off** and press  to confirm.

If the microphone is switched off, the display shows the  symbol and the **The microphone is off** message appears for a short period.

▶ **To switch on:** select **Mike on** and press  to confirm.

The  symbol disappears. You will briefly see the **The microphone is on** message.

Sending DTMF tones



This function is not supported by all mobile phones.



Answering machines or other devices can be controlled by DTMF tones, e.g. for remote query functions.

▶ If you would like to listen to the messages on your answering machine, for example, select the corresponding number.

▶ **To transmit individual characters:** once a connection has been established to the answering machine, select the desired characters in the character bar, pressing  to confirm each of them.

or

▶ Press the corresponding key on the COMAND Online number keypad. Every character selected will be transmitted immediately.

▶ **To send a phone book entry as a DTMF sequence:** select **Name** by turning  the COMAND controller and press  to confirm.

▶ Select the desired phone book entry and press  to confirm. The entry is sent as a DTMF character string.

▶ **To return to the call display:** select **Back** and press  to confirm.

i DTMF tones can also be transmitted using LINGUATRONIC; see the separate operating instructions.

Calls with several participants

Rejecting or accepting a waiting call

The mobile phone network provider must support and activate the call waiting function. Depending on the mobile phone used, the system behaviour differs when accepting a call.

If you have a call in progress and receive another call, a new window appears in the display. You also hear a tone. You can accept or reject the call.

▶ **To reject:** select **Reject** and press  to confirm.

or

▶ Press the  button on COMAND Online or on the multifunction steering wheel.

▶ **To accept:** select **Accept** and press  to confirm.

or

▶ Press the  button on COMAND Online or on the multifunction steering wheel.

The system behaviour after accepting the incoming call depends on your mobile phone.

- The mobile phone supports the call waiting function (via Bluetooth®) when:

the previously active call is held. You can then switch back and forth between both calls (toggling) (▷ page 394).

- The mobile phone does not support the call waiting function (via Bluetooth®) when: the previously active call is ended.

This is also the case if you accept the waiting call using LINGUATRONIC (see the separate operating instructions).

Valid in both cases: if you accept the waiting call using the mobile phone, the active call is put on hold. You then have two calls. The call you have just accepted is active.

The COMAND display changes. If you continue to operate functions on the mobile phone, the COMAND Online display may differ from that of the mobile phone.

Making a second call

If the following conditions are met, you can make a further call during an existing call:

- the function has to be supported by the mobile phone network.
- the mobile phone has to support the connection of a further call via Bluetooth®.
- the appropriate setting has to be activated on the mobile phone.

If your mobile phone allows you to make a second call via Bluetooth®, you can make another while on the phone with someone else. This action puts the previous call on hold. The function is available.



① Symbol for making a second call

- ▶ Select symbol ① by turning the COMAND controller and press to confirm.

or

- ▶ Press the button on COMAND Online.
- ▶ Enter the phone number:
 - manually (▷ page 391)
 - using the phone book (▷ page 396)
 - using the call lists (▷ page 399)
 - using speed dial (▷ page 392)

Toggling

You can switch back and forth between calls with this function. The function is available if your mobile phone supports the toggling function (via Bluetooth®).

You can use the function if you are answering a second call or making a second call.





Switching between the active call and the call on hold

- ① Active call
- ② Call on hold

- ▶ Select symbol ② and press to confirm.

or

- ▶ Press the button on COMAND Online or on the multifunction steering wheel. The previous call on hold is activated.

► **To end the active call:** select  in the telephone basic menu and press  to confirm.

or

► Press the  button on COMAND Online or on the multifunction steering wheel. The call on hold is active.

Conference calls

You can interconnect calls (active and on hold) on the mobile phone. This allows numerous callers to hear and speak to each other; see the mobile phone operating instructions.

You can also make a further call in COMAND Online (► page 394).

Transferring a call

From the hands-free system to the mobile phone

If you want to continue a call in private mode, you will need to perform the necessary steps on the mobile phone (see the mobile phone operating instructions). When using convenience telephony, you may have to remove the mobile phone from the bracket or switch to private mode on the mobile phone. This depends on the type of mobile phone bracket (see the mobile phone operating instructions).

From the mobile phone to the hands-free system

If you want to continue a call using COMAND Online, you will need to perform the necessary steps on the mobile phone (see the mobile phone operating instructions).

In convenience telephony mode, depending on the mobile phone bracket, the telephone must be:

- inserted into the bracket or
- switched to hands-free mode via Bluetooth®

See the mobile phone operating instructions for further information.

Using the phone book

Introduction

The phone book displays the names and phone numbers of all address book entries saved in the COMAND address book. If an address book entry does not have a telephone number, it does not appear in the phone book.

In addition, **MB Contact** is listed as the first entry. This allows you to place a call to the Mercedes-Benz Service hotline (► page 414).

The phone book of the mobile phone is automatically downloaded to COMAND Online after connection.

In the telephone book, you can:



- save phone numbers (► page 398)
- search for entries (► page 396)
- delete entries (► page 397)
- import contacts (► page 411)
- delete contacts (► page 412)
- receive vCards (► page 412)

i The stored phone book and the vCards remain in COMAND Online even if you use COMAND Online with another mobile phone. The entries can be viewed without a mobile phone. For this reason, you should delete any phone book entries before handing over or selling the vehicle.

Calling up the phone book

Opening the phone book

► Press the  function button.

► Select **Name** in the telephone basic menu by turning  the COMAND controller and press  to confirm.

If the phone book contains entries, they will be displayed in alphabetical order. The character bar at the bottom of the display is active.

The character bar is used for fast selection of an entry.

Enter the character using the character bar (> page 298).



- i** You can also call up the phone book using the multifunction steering wheel; see the separate vehicle Owner's Manual.

Closing the phone book

- ▶ Select the symbol in the character bar by sliding and turning the COMAND controller and press to confirm.

or

- ▶ Press the back button.

Using the multifunction steering wheel

- ▶ Use the or button to select the **Tel** menu.
- ▶ Use the , or button to call up the phone book.

Symbol overview

Symbol	Explanation
	Address book entry that has been entered or changed via COMAND Online Imported contact that has been saved in the phone or address book
	Address book entry with voice tag These entries have also been assigned a voice tag. Voice tags are available in vehicles with LINGUATRONIC (see the separate operating instructions).
	Contact imported from a mobile phone that supports PBAP or imported from a convenience phone
	Entry which has been imported from the SD memory card or USB device
	Entry imported via the Bluetooth® interface

Searching for a phone book entry

Searching with the character bar



You determine the first letter of the entry you are looking for with the first character you enter.

- ▶ Select a character by turning the COMAND Controller and press to confirm.

The first entry in the list that starts with the letter selected is highlighted. If there are similar entries, the next different character is shown. For example, with entries such as **Christel** and **Christine**, the beginnings of the names are similar. In this case, you will be offered a choice between **E** and **I**.

- ▶ Select the characters of the entry you are searching for one by one and press  to confirm.

When the selection is clear, COMAND Online switches automatically to the selection list.

- ▶ **To complete the search:** slide  the COMAND controller repeatedly or press and hold  until the character bar disappears.

The selection list appears.

Information about character entry
(▶ page 298)

Searching with the number keypad



You determine the first letter of the entry you are looking for with the first character you enter.

- ▶ Press the appropriate number keys as many times as necessary and one after the other.





Further information on character entry using the number keypad (direct entry)
(▶ page 300).

Directly from the list





You can switch to the list at any time during character entry.

- ▶ Slide  the COMAND controller repeatedly or press and hold  until the character bar disappears.

or





- ▶ Select  and press  to confirm.
- ▶ **To select an entry:** turn  the COMAND controller until the desired entry is highlighted and press  to confirm.

To select a phone number: the  symbol indicates that an entry contains more than one phone number.

- ▶ Select a phone book entry with the  symbol and press  to confirm. The sub-entries appear. The  symbol changes to .



Phone book entry with several entries

- ▶ Select a sub-entry by turning  and press  to confirm.
- ▶ **To return to the phone book using the character bar:** select  in the list and press  to confirm.





or

- ▶ Press the  back button.

Using the multifunction steering wheel

- ▶ Dialling a number from the phone book, see the separate vehicle Owner's Manual.

Displaying the details of an entry

- ▶ Select an entry in the selection list by turning  the COMAND controller.
- ▶ Select the list symbol to the right of the entry by sliding  the COMAND controller and press  to confirm.
- ▶ Select **Details** and press  to confirm. The detailed display appears.

- ▶ **To close the detailed display:** slide  repeatedly until the entry is highlighted again.

or

- ▶ Press the  back button.

Deleting an entry from the phone book

If the entry contains only phone numbers, it is deleted from the phone book and address book.

If it contains additional data, such as a navigable destination, the entry is deleted in the phone book. However, the entry is retained in the address book.

- ▶ Select an entry in the selection list by turning **⏪** the COMAND controller.
- ▶ Select the list symbol to the right of the entry by sliding **⏪** the COMAND controller and press **⏩** to confirm.
- ▶ Select **Delete** and press **⏩** to confirm. A prompt appears asking whether the entry should be deleted.
- ▶ Select **Yes** or **No** and press **⏩** to confirm. If you select **Yes**, the entry is deleted in accordance with the rules described above. If you select **No**, the process will be cancelled.

Creating a new entry in the phone book

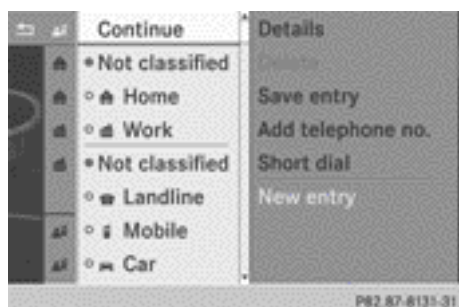

- ▶ Slide **⏪** the COMAND controller repeatedly in the phone book until the selection list appears.
- ▶ Select the list symbol on the right in the selection list by sliding **⏪** the COMAND controller and press **⏩** to confirm.
- ▶ Select **New entry** and press **⏩** to confirm.
- ▶ Select a category for the number, e.g. **Home**, and press **⏩** to confirm.
- ▶ Select a category for the phone, e.g. **Mobile**, and press **⏩** to confirm.
- ▶ Select **Continue** and press **⏩** to confirm. The input menu with data fields appears.

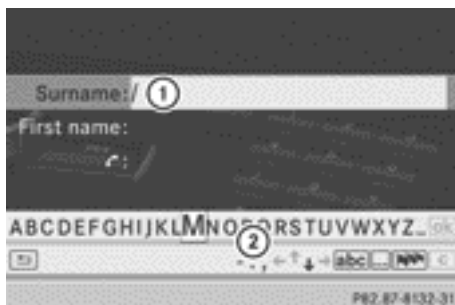



- ① Selected data field with cursor
- ② Character bar
- ▶ Enter characters (▷ page 298)
- ▶ **To save an entry:** turn **⏪** the COMAND Controller to select the **ok** symbol from the character bar and press **⏩** to confirm. The entry is created in the phone book and in the address book.

Adding to a phone book entry

You can add telephone numbers to an existing phone book entry.

- ▶ Select an entry in the selection list by turning **⏪** the COMAND controller.
- ▶ Select the list symbol to the right of the entry by sliding **⏪** the COMAND controller and press **⏩** to confirm.
- ▶ Select **Add telephone no.** and press **⏩** to confirm.
- ▶ Select a category for the number, e.g. **Home**, and press **⏩** to confirm.
- ▶ Select a category for the phone, e.g. **Mobile**, and press **⏩** to confirm.
- ▶ Select **Continue** and press **⏩** to confirm. COMAND Online stores the data if there are fewer than five numbers assigned to the entry you are searching for in the selected number category. If five numbers are stored for the entry in the selected number category, a prompt will appear. You can then choose whether to overwrite one of the existing numbers.

- ▶ Select **Yes** or **No** and press  to confirm. If you select **Yes**, a selection list will appear containing the five existing numbers. If you select **No**, the process will be aborted.
- ▶ Select the number to be overwritten by turning  the COMAND controller and press  to confirm. An input menu appears. The data field for entering the new phone number is highlighted.
- ▶ Enter characters (▷ page 298)
- ▶ Store an entry (▷ page 299)

Using call lists

Introduction

While the telephone is being used, COMAND Online stores individual lists for both incoming and outgoing calls (including missed calls). Call lists are not available unless a mobile phone is connected to COMAND Online.





COMAND Online supports the PBAP Bluetooth® profile. For this reason, note that the system behaviour differs, especially when telephoning via the Bluetooth® interface:

- Convenience phone or Bluetooth® telephone with PBAP Bluetooth® profile:
The call lists are downloaded automatically from the mobile phone by COMAND Online as soon as the mobile phone is connected to COMAND Online. COMAND Online displays entries without time information if these have been downloaded in convenience telephony mode.
 - Bluetooth® telephone without PBAP Bluetooth® profile:
The call lists are created and displayed by COMAND Online.
- i** For Bluetooth® telephones without the PBAP Bluetooth® profile, the call lists in COMAND Online are not synchronised with those on your mobile phone. These calls

may or may not be listed on your mobile phone, depending on the model.

- i** If no mobile phone is connected, then the **Call lists** menu item is greyed out and cannot be selected. If you connect a mobile phone other than the previous one to COMAND Online, the previously available call lists and their entries will be deleted automatically. These are still available on the mobile phone itself.
- i** You will only be able to select the respective menu items once calls have been received or dialled from COMAND Online. Displaying missed calls in the COMAND display is not supported by all mobile phones.

Opening the call list and selecting an entry

- ▶ Press the  function button.
- ▶ Select **Call lists** in the telephone basic menu by sliding  and turning  the COMAND controller and press  to confirm. A menu appears.

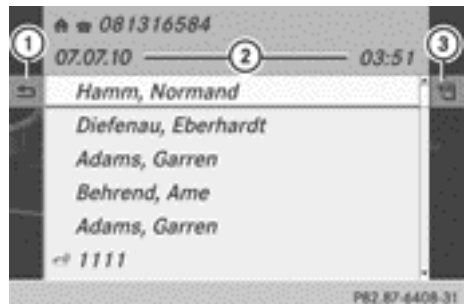

Example: list of selected phone numbers

- ① To close the list
- ② Date/time (if available), symbols (if assigned) and telephone number of the entry highlighted
- ③ To call up options

- ▶ Select **Incoming calls** or **Calls dialled** by turning and press to confirm.

The corresponding list appears.

- ① You can also call up the list of dialled calls by pressing the button when the telephone basic menu is shown. In this case, the list will only show phone numbers.

- ▶ Select an entry by turning the COMAND controller.

- ▶ **To dial a phone number:** press .

- ▶ **To close the list:** select the symbol and press to confirm.

or

- ▶ Press the back button.

Displaying details from a list entry

COMAND Online can also show a shortened list entry in full.

- ▶ Select a list entry by turning the COMAND controller.
- ▶ Select the list symbol to the right of the entry by sliding the COMAND controller and press to confirm.
- ▶ Select **Details** and press to confirm. The detailed display appears.
- ▶ **To go back to the list:** slide repeatedly until the list is highlighted.

Storing a phone number

New address book entry

For incoming calls from a person who is not in the address book, COMAND Online displays the phone number in the call list. You can save this entry.

- ▶ Open a call list and select an entry ([▷ page 399](#)).
- ▶ Select the list symbol to the right of the entry by sliding the COMAND controller and press to confirm.

- ▶ Select **Save** and press to confirm.
- ▶ Select **New entry** and press to confirm.
- ▶ Select a category for the number, e.g. **Home**, and press to confirm.
- ▶ Select a category for the phone, e.g. **Mobile**, and press to confirm.

Number category	Display (phone book and address book)
Not classified	No symbol
Home	
Work	

Phone category	Display (phone book and address book)
Not classified	
Landline	
Mobile	
Car	



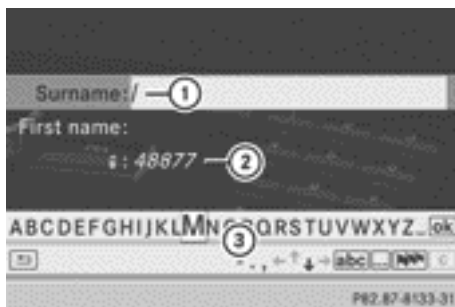



- ▶ Select **Save** and press to confirm. An input menu with data fields is shown. The data field for the telephone number is filled in automatically.



- ① Data field with cursor
- ② Telephone number and symbol for the phone category are automatically entered
- ③ Character bar



Adding information to an address book entry

For incoming calls from a person who is not in the address book, COMAND Online displays the phone number in the call list. You can save this entry.

- ▶ Open a call list and select an entry (▷ page 399).
- ▶ Select the list symbol to the right of the entry by sliding  to the COMAND controller and press  to confirm.
- ▶ Select **Save** and press  to confirm.
- ▶ **i Save** is shown in grey if the selected list entry has already been saved.
- ▶ Select **Add telephone no.** and press  to confirm.
- ▶ Select a category for the number, e.g. **Home**, and press  to confirm.
- ▶ Select a category for the phone, e.g. **Mobile**, and press  to confirm.
- ▶ Select **Save**.
The search menu for address book entries appears.
- ▶ Search for the desired entry (▷ page 396).
- ▶ Press  when you have finished searching. COMAND Online stores the data if there are fewer than five numbers assigned to the entry you are searching for in the selected number category.

You will see a message to this effect.





If five numbers are stored for the entry you are searching for, a prompt will appear asking whether you wish to overwrite one of the existing numbers.

- ▶ Select **Yes** or **No** and press  to confirm.
If you select **Yes**, a selection list with the five existing numbers is displayed.
If you select **No**, the process will be aborted.
- ▶ Select the number to be overwritten in the list by turning  the COMAND controller and press  to confirm.
COMAND Online overwrites the selected number with the new data.

Deleting call lists

If you are using a Bluetooth® phone that does not support the PBAP Bluetooth® profile, the call lists are generated and managed by COMAND Online. You can delete these call lists in COMAND Online.

You cannot delete call lists from COMAND Online:

- if the connected Bluetooth® phone supports the PBAP Bluetooth® profile
- in convenience telephony mode
- ▶ Select **Call lists** in the telephone basic menu by turning  the COMAND controller and press  to confirm.
- ▶ Select **Delete call lists** and press  to confirm.
A prompt appears asking whether you wish to delete all call lists.
- ▶ Select **Yes** or **No** and press  to confirm.
If you select **Yes**, the call lists are deleted.
If you select **No**, the process will be aborted.

- ▶ **i** If you delete these call lists from the mobile phone (see the separate mobile phone operating instructions), COMAND Online updates the call list display the next time it connects.

Using the speed dial list

Storing an entry

You can assign ten speed dial presets (0 – 9) in the speed dial list. There are two options available for this purpose.

Option 1:

- ▶ Search for a phone book entry in the phone book (▷ page 396).
- ▶ If an entry has several phone numbers, select the desired number by turning  the COMAND controller.

- ▶ Select the list symbol to the right of the entry by sliding $\odot \rightarrow$ the COMAND controller and press \odot to confirm. A menu appears.
- ▶ Select **Speed dial** by turning \updownarrow the COMAND controller and press \odot to confirm. A menu appears.

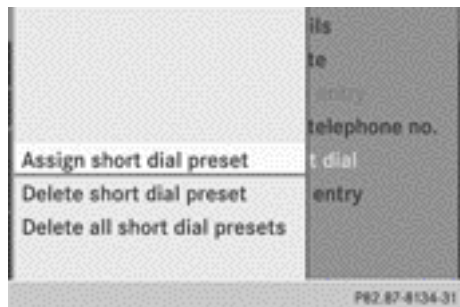

Speed dial menu

- ▶ Select **Assign speed dial preset** and press \odot to confirm. The speed dial list appears. The selected phone book entry appears at the top. The next free speed dial preset is highlighted.



- ▶ Select the speed dial preset by turning \updownarrow the COMAND controller and press \odot to confirm. The phone book entry is saved in the speed dial preset.

Option 2

- ▶ Call up the telephone basic menu:

- convenience telephony (▷ page 388)
- telephony via the Bluetooth® interface (▷ page 386)
- ▶ Select **Call lists** by sliding $\odot \downarrow$ and turning \updownarrow the COMAND controller and press \odot to confirm.
- ▶ Select **Speed dial preset list** and press \odot to confirm. The speed dial list appears.
- ▶ Select the list symbol to the right of the entry by sliding $\odot \rightarrow$ the COMAND controller and press \odot to confirm.
- ▶ Select **Assign speed dial preset** and press \odot to confirm. The speed dial list appears. The selected phone book entry appears at the top. The next free speed dial preset is highlighted.



- ▶ Select the speed dial preset by turning \updownarrow the COMAND controller and press \odot to confirm. The phone book entry is saved in the speed dial preset.

Using speed dial presets to make a call

The speed dial list contains stored phone book entries (▷ page 401).

Option 1:

- ▶ Press one of the number keys for longer than two seconds. The telephone basic menu displays the selected entry. This initiates dialling.

Option 2:

- ▶ Call up the telephone basic menu:
 - convenience telephony (▷ page 388)
 - telephony via the Bluetooth® interface (▷ page 386)
- ▶ Select **Call lists** by sliding and turning the COMAND controller and press to confirm.

The speed dial list appears.
- ▶ Select **Speed dial preset list** by turning the COMAND controller and press to confirm.

The speed dial list appears.
- ▶ Select preset and press to confirm.

The telephone basic menu displays the selected entry. This initiates dialling.

Deleting a speed dial preset

- ▶ **To delete a speed dial number:** select **Delete speed dial preset** in the Speed dial menu by turning the COMAND controller and press to confirm.

The speed dial preset is deleted.
- ▶ **To delete all speed dial numbers:** select **Delete all speed dial presets** in the Speed dial menu by turning the COMAND controller and press to confirm.

You will be asked if you would like to continue.
- ▶ Select **Yes** or **No** and press to confirm.

If you select **Yes**, all speed dial presets will be deleted from the speed dial list.

If you select **No**, the process will be cancelled.

Text messages (SMS)**Information and requirements**

The following conditions must be met in order to use the functions:

Type of telephony	Conditions
Telephony via the Bluetooth® interface	<ul style="list-style-type: none"> • The Bluetooth® mobile phone supports the MAP Bluetooth® profile (Message Access Profile).
Convenience telephony	<ul style="list-style-type: none"> • The mobile phone bracket supports the SMS function. • The mobile phone is connected to the mobile phone bracket and COMAND Online. • The PIN has been entered. • The mobile phone is logged into a mobile phone network.

When the mobile phone is connected, the 30 most recent text messages that are currently stored on the phone are loaded to the COMAND Online text message inbox and displayed.

If the above conditions are met, new incoming text messages appear in the COMAND Online text message inbox. In addition, a tone sounds and the symbol appears. The symbol is no longer displayed once you have read the text message. The mail symbol is displayed if the text message memory is full. The symbol is no longer displayed once you delete at least one text message.

For telephony via a data-enabled MB SAP module, see the data-enabled MB SAP module's separate operating instructions.

COMAND Online may not load all of the most recent text messages:

This may occur in exceptional cases, for example when using certain mobile phones/brackets and if the mobile phone inbox holds a large number of text messages.

i For more information about suitable mobile phones and mobile phone brackets, contact your Mercedes-Benz Service Centre or visit [http:// www.mercedes-benz.com/connect](http://www.mercedes-benz.com/connect).

Displaying the text message (SMS) inbox

Call up the inbox



Text message (SMS) inbox

- ▶ Press the **TEL** function button.
- ▶ Select **SMS** in the telephone basic menu by turning **⏮** the COMAND controller and press **⏹** to confirm. The text message inbox appears.

Reading a text message (SMS)

- ▶ Calling up the text message inbox (▷ page 404)
- ▶ Select a text message in the text message inbox by turning **⏮** the COMAND controller and press **⏹** to confirm. The text message appears.
- ▶ **To scroll through the display or select phone numbers in a text message:** turn **⏮** the COMAND controller. The display scrolls up or down line by line, or skips to the next or previous telephone number and automatically highlights it.
- ▶ **To return to the list:** select the **☐** symbol and press **⏹** to confirm or press the **⏪** back button.

Text message read-aloud function

Settings for the read-aloud function:

- Language (▷ page 306)
- Speed (▷ page 305)
- ▶ Press **⏮** while a text message is being displayed, select **Read aloud** and press **⏹** to confirm. COMAND Online reads out the text message.

- ▶ **To cancel the read-aloud function:** press the **⏪** button.

or

- ▶ Press **⏮**, select **Cancel read-aloud function** and press **⏹** to confirm.







Sender or text display

You can switch between displaying the text message sender or the text message content. The sender display shows the sender of the text message. If the sender is stored in the COMAND phone book, the name is displayed. The text display shows the first few words of a text message.

- ▶ Select a text message in the text message inbox by turning **⏮** the COMAND controller.
- ▶ **To switch to the text display:** select the list symbol to the right of the text message by sliding **⊙→** the COMAND controller and press **⏹** to confirm.
- ▶ Select **Display text** and press **⏹** to confirm. The view changes.
- ▶ **To switch to the sender display:** select the list symbol to the right of the text message by sliding **⊙→** the COMAND controller and press **⏹** to confirm.
- ▶ Select **Display sender** and press **⏹** to confirm. The view changes.
- ▶ **To return to the telephone basic menu:** press the **☐** button.



Displaying details and phone numbers

COMAND Online can also show a shortened sender display in full.

- ▶ Select a text message in the text message inbox by turning  the COMAND controller.
- ▶ Select the list symbol to the right of the text message by sliding  the COMAND controller and press  to confirm.
- ▶ Select **Details** and press  to confirm. The detailed display appears.
- ▶ **To close the detailed view:** slide  the COMAND controller.
- ▶ **To return to the telephone basic menu:** press the  button.

Managing text messages

Calling a text message (SMS) sender

- ▶ Press  the COMAND controller while the text message is being displayed.
- ▶ Select **Call sender** and press  to confirm. The telephone makes the call to the sender.

Using phone numbers in the text



- ① Usable numerical sequence

Numbers in text messages that are highlighted in red can be used.

- ▶ Select a usable number when the text message is displayed.



- ▶ Press  the COMAND controller and select **Use**.
- ▶ Select **Call**. The telephone makes the call.

i It is possible that a highlighted numerical sequence may not contain a telephone number.



i You can use the "New entry" or "Add no." functions to save this telephone number or to add it to an existing entry.

Storing the sender of a text message in the address book



This function is not available if the sender's telephone number is already stored in the address book.



- ▶ Press  the COMAND controller while the text message is being displayed.
- ▶ Select **Save number** and press  to confirm.
- ▶ Select **New entry** and press  to confirm.
- ▶ Store the phone number (▷ page 400)

Adding the sender of a text message to an address book entry

- ▶ Press  the COMAND controller while the text message is being displayed.
- ▶ Select **Save number** and press  to confirm.
- ▶ Select **Add telephone no.** and press  to confirm.
- ▶ Proceed from the step "Selecting a number category" (▷ page 398).

Deleting a text message (SMS)

- ▶ Select a text message in the text message inbox by turning  the COMAND controller.
- ▶ Select the list symbol to the right of the text message by sliding  the COMAND controller and press  to confirm.

- ▶ Select **Delete** and press  to confirm. A deletion prompt appears.
 - ▶ Select **Yes** or **No** and press  to confirm. If you select **Yes**, the text message is deleted. If you select **No**, the process will be cancelled.
- i** This delete function is not supported by all mobile phones. The **Delete failed** message appears.

Using the address book

Introduction

The address book organises and stores entries that are entered from different sources (mobile phone, memory card, USB device, COMAND telephone book, navigation system).

You can use these entries to make telephone calls and to navigate.

- i** **Number of contacts in the address book:** the address book can store a total of 4,000 contacts. 1,500 entries each are reserved in the address book for:
- contacts from the mobile phone
 - contacts that you create in COMAND or import from other sources.
- The remaining 1,000 entries are assigned by COMAND as necessary.

- i** **Display of mobile phone contacts:** contacts downloaded from the mobile phone remain in the address book even if you disconnect the mobile phone from COMAND Online. Contacts that have previously been available can be displayed as soon as the mobile phone is reconnected. COMAND Online downloads the contacts again so that any new contacts that have been added to the mobile phone can be displayed.



As soon as you connect a new mobile phone to COMAND, all the contacts from the previous mobile phone are replaced by those from the new phone's address book. Address book entries remain stored if the mobile phone is disconnected. For this reason, delete your personal data using the reset function before selling your vehicle, for example (▷ page 308).

Calling up the address book

Using the function button:

- ▶ Press the **TEL** function button. You see either the telephone basic menu or the address book, depending on which was last active.
- ▶ If the telephone basic menu is displayed, press the **TEL** function button again.

Using the telephone basic menu:

- ▶ With the telephone basic menu shown, select **Tel** by sliding  the COMAND controller and press  to confirm.
- ▶ Select **Address book** from the menu and press  to confirm.



Address book with  address book entry and  navigable data

- ▶ **To browse in the address book:** turn  the COMAND controller.
- ▶ **To close the address book:** press the **TEL** button.

i An address book entry can contain the following information:

- surname
- first name
- company
- two addresses
- geo-coordinates
- up to five telephone numbers

Searching for an address book entry



Search menu with character bar

- ① Address book entry
- ② Complete address data from the navigation system
- ③ Character bar
- ④ Phone book entry on the mobile phone
- ⑤ Entry with voice tag

For more symbols, see the symbol overview (▷ page 396).

- ▶ Search for an entry (▷ page 396)

Creating a new entry in the address book

You can enter address data directly into the address book. If you store telephone numbers in the COMAND phone book, these are also saved in the address book. If you store a navigation destination, COMAND creates an address book entry that includes the complete navigable address data.

- ▶ Call up the address book (▷ page 406)

- ▶ Select **New** in the address book by sliding and turning the COMAND controller and press to confirm. An input menu with data fields appears.



Input menu with data fields

- ① Selected data field with cursor
- ② Character bar

- ▶ Enter characters (▷ page 298)
- ▶ Store an entry (▷ page 299)

Deleting an address book entry

- ▶ **Option 1:** select **Delete** in the address book by sliding and turning the COMAND controller and press to confirm.
- ▶ **Option 2:** search for an address book entry (▷ page 396).
- ▶ Select the list symbol to the right of the entry by sliding the COMAND controller and press to confirm.
- ▶ Select **Delete** and press to confirm. Irrespective of the option chosen, a prompt will appear.
- ▶ Select **Yes** or **No** and press to confirm. If you select **Yes**, the entry will be deleted. If you select **No**, the process will be cancelled.

Displaying details for an address book entry

Selecting an entry



Detailed display of address book

- ① To go back to the previous menu
- ② Business details
- ③ List symbol (calls up options)

- ▶ Search for an address book entry (▷ page 396)
- ▶ Select an entry in the selection list by turning the COMAND controller.

or

- ▶ Call up the address book (▷ page 406)
- ▶ Select an entry by turning the COMAND controller.
- ▶ Press the COMAND controller. The detailed display appears.

Starting route guidance to an address

- ▶ Select the address data field by turning the COMAND controller and press to confirm. The route to the destination address is calculated and route guidance starts (▷ page 321).

Calling a telephone number

- ▶ Select the phone number data field by turning the COMAND controller and press to confirm. This initiates dialling and you can then make your call (▷ page 392).

Showing the details of an address book entry

- ▶ Select the list symbol to the right of the entry by sliding the COMAND controller and press to confirm.
- ▶ Select **Details** and press to confirm. The display is shown in full.
- ▶ **To close the detailed display:** press the back button.

Changing an address book entry

- ▶ **Option 1:** search for an address book entry (▷ page 396).
- ▶ Select an entry in the selection list by turning the COMAND controller.
- ▶ Select the list symbol to the right of the entry by sliding the COMAND controller and press to confirm. A menu appears.

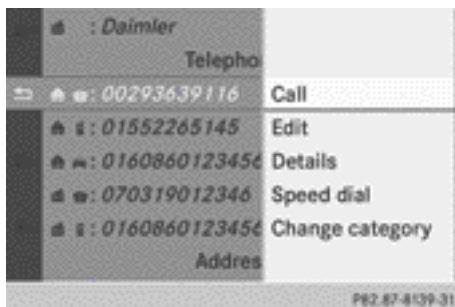

- ▶ Select **Edit** and press to confirm.
- ▶ **Option 2:** call up the detailed view for an address book entry (▷ page 408).
- ▶ Select the list symbol to the right of the entry by sliding the COMAND controller and press to confirm.
- ▶ Select **Edit** and press to confirm. In both cases, the input menu containing data fields appears.

Information about character entry (▷ page 298)

Changing the category of a telephone number data field

- ▶ Display details for an address book entry (▷ page 408).
- ▶ Select the telephone number data field.
- ▶ Select the list symbol to the right of the entry by sliding the COMAND controller and press to confirm.
- ▶ Select **Change category** and press to confirm.
- ▶ Select a number category, e.g. **Home**.
- ▶ Select a telephone category, e.g. **Mobile**.
- ▶ If desired, select **Preferred** and press to confirm.
Depending on the previous status, switch the option on or off . The phone number is displayed as the first number in the phone book and can be dialled immediately.
- ▶ Select **Save** and press to confirm.
The new category is stored.

Calling a number stored in an entry

Conditions

The mobile phone must either:

- be inserted in the mobile phone bracket (▷ page 386)
- or be connected via the Bluetooth® interface (▷ page 381)

Dialling a number

- ▶ Display details for an address book entry (▷ page 408).
 - ▶ Select the phone number data field by turning the COMAND controller.
 - ▶ Press the COMAND controller to confirm.
- or
- ▶ Select the list symbol to the right of the data field by sliding the COMAND controller.

- ▶ Press the COMAND controller to confirm.
- ▶ Select **Call** and press to confirm.
The telephone makes the call. The display switches to telephone mode.

Storing the phone number as a speed dial number

- ▶ Display details for an address book entry (▷ page 408).
- ▶ Select the phone number data field by turning the COMAND controller.
- ▶ Select the list symbol to the right of the data field by sliding the COMAND controller and press to confirm.
- ▶ Select **Speed dial** and press to confirm.
You can now store the number in one of the ten speed dial presets (▷ page 401).

Starting route guidance to an entry

Address book entry with navigable data

This function is available as soon as you have stored a destination in the destination memory (▷ page 360).

- ▶ Search for an address book entry with the symbol and select it from the list (▷ page 407).
- ▶ Display details for an address book entry (▷ page 408).
- ▶ Select the address data field by turning the COMAND controller and press to confirm.
Route guidance begins.

or

- ▶ Select the list symbol to the right of the entry by sliding the COMAND controller and press to confirm.
- ▶ Select **Navigate** and press to confirm.
Route guidance begins.

Address book entry without navigable data

Route guidance can also be started for an address book entry without the  symbol. If the address data or designations do not match the digital map, COMAND Online prompts you to re-enter the address.

- ▶ Enter the destination address (▷ page 317).
- ▶ Start route guidance
The navigable address is automatically added to the address book entry.



i This will provide you with an address book entry that is suitable for navigation. If you have changed the address data in the address entry menu, navigation uses the modified address data rather than the postal address when it is next started. When starting navigation you should therefore always check the address book to ensure that the destination address corresponds to your desired destination.



Voice tags

Introduction





You can enter voice tags via LINGUATRONIC (see the separate operating instructions). Once you have assigned a voice tag to an address book entry, you can vocally call up this entry and dial a phone number, for example. You can add one voice tag per address book entry.

Adding or changing a voice tag





- ▶ Search for an address book entry with or without a voice tag () (▷ page 407).
- ▶ Select the list symbol to the right of the entry by sliding  the COMAND controller and press  to confirm.

- ▶ Select **Voice tag** and press  to confirm.
- ▶ Select **Add** or **Change** and press  to confirm.
Subsequent operation is voice-controlled. LINGUATRONIC guides you through the dialogues.

Deleting a voice tag

- ▶ Search for an address book entry with a voice tag (▷ page 407).
- ▶ Select the list symbol to the right of the entry by sliding  the COMAND controller and press  to confirm.
- ▶ Select **Voice tag** and press  to confirm.
- ▶ Select **Delete** and press  to confirm.
A deletion prompt appears.
- ▶ Select **Yes** or **No** and press the  button to confirm.
If you select **Yes**, COMAND Online deletes the voice tag.
If you select **No**, the process will be cancelled.

Listening to a voice tag

- ▶ Search for an address book entry with a voice tag (▷ page 407).
- ▶ Select the list symbol to the right of the entry by sliding  the COMAND controller and press  to confirm.
- ▶ Select **Voice tag** and press  to confirm.
- ▶ Select **Listen** and press  to confirm.
You hear the voice tag.





Importing phone book entries

This function allows you to store phone book entries from the mobile phone in the address book.



Possible sources are:

- the mobile phone
- the memory card
- the USB device
- the Bluetooth® interface

Imported phone book entries are indicated in the phone book by different symbols (▷ page 396).

- ▶ Search for an entry in the phone book on the mobile phone  (▷ page 396).
- ▶ Select the list symbol to the right of the entry by sliding  the COMAND controller and press  to confirm.
- ▶ Select **Save entry** and press  to confirm.

The **Data saved** message appears. The phone book entry is now saved as an address book entry.

The  symbol is replaced by the  symbol.

Importing contacts

Information and requirements

You can import contacts (vCards) from the memory card and from a USB device into the address book, or receive vCards via Bluetooth®.

- i** Up to 2,500 entries can be imported into the address book. A message notifies you if the maximum number is reached. You then have to delete existing entries in order to import new entries (▷ page 407).

Depending on the source of the contact data, different requirements apply:

Source	Conditions
memory card	The SD memory card is inserted (▷ page 463). It contains importable contact details.
USB device	The USB device is inserted into the USB port (▷ page 463). It contains importable contact details.

Requirements for receiving vCards via Bluetooth®

You can receive vCards from devices (e.g. from a PC) that support the sending of vCards via Bluetooth®.

It is not necessary to authorise the device in COMAND to do so.

Please bear the following in mind:

- Bluetooth® must be activated in COMAND and on the Bluetooth® device; see the operating instructions for the device.
- the Bluetooth® device must be able to send vCards via Bluetooth® (see the operating instructions for the device).
- the Bluetooth® device in the vehicle must be switched on.







Importing from the memory card or USB device

Entries imported from the memory card or from a USB device have the  symbol.

The following conditions must be fulfilled in order to import vCards:

- vCards (vcf files) may be located in the main directory or in folders. COMAND allows you to select the relevant folders directly.
- vCards must have the ".vcf" file extension.

- i** One vcf file may contain several vCards. COMAND supports vCards in versions 2.1 and 3.0.

- ▶ Select **Address book** in the address book or, if the telephone basic menu is shown, select **Telephone** by sliding  and turning  the COMAND controller and press  to confirm.
- ▶ Select **Import contacts** and press  to confirm. A menu appears.
- ▶ Select **From the memory card** or **From USB device** in the menu by turning  the COMAND controller and press  to confirm.

- ▶ Select **Add** or **Overwrite** and press  to confirm.

Add imports the entries from the memory card or USB device into the address book.



Overwrite imports the entries from the memory card or USB device and overwrites all entries in the address book with the  symbol. The previous entries are then no longer available.

After the contact data has been imported successfully, you will see a message to this effect. The address book or the respective telephone basic menu is displayed.



- ❗ You can select **Overwrite** if the address book already contains corresponding entries. A message notifies you if the address book is full.

Receiving vCards via Bluetooth®





- ▶ Select **Address book** in the address book or, if the telephone basic menu is shown, select **Telephone** by sliding  and turning  the COMAND controller and press  to confirm.

A menu appears.

- ▶ Select **Import contacts** and press  to confirm.
- ▶ Select **Receive business cards** in the menu by turning  the COMAND controller and press  to confirm. This interrupts the Bluetooth® connection between COMAND and your active mobile phone. COMAND is, however, ready to receive vCards from another Bluetooth® device (PC, mobile phone).

- ▶ Start the data transfer on the external Bluetooth® device (see the operating instructions for the device).



The number of vCards received is displayed.

- ▶ **To end reception:** press  or the  back button. COMAND Online then reconnects to the mobile phone.

Received vCards are identified by the  symbol in the address book.

- ❗ If you switch to another main function, e.g. navigation, while receiving vCards, the reception of vCards will be terminated.

Deleting contacts

- ▶ Select **Address book** in the address book or, if the telephone basic menu is shown, select **Telephone** by sliding  and turning  the COMAND controller and press  to confirm.

A menu appears.

- ▶ Select **Delete contacts** and press  to confirm.
- ▶ Select one of the following options:
 - **Internal contacts**
 - **Contacts from storage device**
 - **Received business cards**
 - **Delete all**

A prompt corresponding to your selection appears.

- ▶ Select **Yes** or **No** and press  to confirm. If you select **Yes**, the contacts are deleted according to your selection. If you select **No**, the process will be cancelled.

Switching import contacts on/off



You can determine whether contacts are automatically imported to COMAND Online when you connect a mobile phone, or whether importing is suppressed.

Connecting a mobile phone (▷ page 381)

- ▶ Select **Tel** in the telephone basic menu by sliding $\odot \downarrow$ and turning $\left[\odot \right]$ the COMAND controller and press \odot to confirm. A menu appears.
- ▶ Select **Import contacts from <my phone>** and press \odot to confirm. Either you allow the automatic upload or you suppress the function .

If you do not want to store sensitive contacts in the address book, proceed as follows:

- ▶ Connect the mobile phone to COMAND Online. The contacts are automatically imported to the address book.
- ▶ Delete the sensitive contacts from the address book.
- ▶ Switch the **Import contacts from <my phone>** function off . When you reconnect your mobile phone to COMAND Online, no contacts will be imported, including any that have been added.

Activating/deactivating the display of contact details (privacy)

The **Hide data** setting allows you to determine whether or not phone and address book data is shown on the screen. This means that,

for instance, you can prevent a passenger from seeing a caller's name.

Activating the function has the following effects:

- Phone book and address book data from the mobile phone are hidden. This means that they cannot be used to make calls, send text messages or for navigation. You still have access to phone book and address book data stored in COMAND Online.
- When receiving a call, the name of the caller will not be shown, even if there is an address book entry for the number of the incoming call.
- When making a call by entering the phone number, the name of the person you are calling will not be shown, even if there is an address book entry for that number.
- The call lists are hidden.
- Redialling is not possible.
- The list of received text messages is hidden. Incoming text messages are still indicated. This is only possible if a mobile phone which supports the MAP profile is connected. However, the phone number is not visible and cannot be accessed quickly, e.g. by a passenger.



Connecting a mobile phone (▷ page 381)

- ▶ Select **Tel** in the telephone basic menu by sliding $\odot \downarrow$ and turning $\left[\odot \right]$ the COMAND controller and press \odot to confirm. A menu appears.

- **To hide details:** select **Hide data:** <my phone> and press  to confirm. You either allow or suppress access to the address details.

Mercedes-Benz Contact

Introduction

Mercedes-Benz Contact offers fast assistance at the touch of a button – around the clock. For any queries about the vehicle, Mercedes-Benz Contact offers a fast and easy connecting call to the Mercedes-Benz Customer Centre. You can request an appointment, or call for help in the event of a breakdown.

All important vehicle data is sent via mobile phone to ensure that you receive optimum support. Therefore, the mobile phone has to be directly connected to COMAND Online via the Bluetooth® interface or convenience telephony.

The following data is transmitted:

- the vehicle identification number
- the total distance recorder reading
- the vehicle position
- the telephone number
- the service code (only when required for maintenance)

i Please note that Mercedes-Benz Contact is a Mercedes-Benz customer service. In emergencies, always call the national emergency services first, using the standard national emergency service telephone numbers.

- i** Currently, this service is available for vehicles from the following European countries:
- Belgium
 - Germany
 - France
 - United Kingdom
 - Ireland

- Italy
- Luxembourg
- Netherlands
- Austria
- Poland
- Switzerland
- Slovakia
- Spain
- Czech Republic
- Hungary

Calling the Mercedes-Benz Customer Centre

WARNING

Pay attention to the traffic conditions. You may otherwise be distracted from the traffic conditions, cause an accident and injure yourself and others.

- Call up the COMAND phone book (▷ page 395).

The **MB Contact** entry is the first entry in the COMAND phone book. The entry is highlighted.

There are two ways to contact the Mercedes-Benz Customer Centre:

- Press  the COMAND controller.

or

- Press the  button on COMAND Online. This initiates a call. A voice announcement will then request that you confirm the data transfer by pressing the specified number on the COMAND Online keypad. After confirmation, COMAND Online sends the required vehicle data.

i Alternatively, you can initiate a call using the multifunction steering wheel (see the vehicle Owner's Manual).





During data transmission, you will see a corresponding symbol in the display. This may take a moment. Then, you can select the desired service and be connected to a specialist from the Mercedes-Benz Service Centre.

- i Contact your Mercedes-Benz Service Centre for further information on Mercedes-Benz Contact, the range of services offered and on using the function.

Demand-actuated service message

To attain the optimal level of support in maintaining your vehicle, you can arrange a service appointment directly with the Mercedes-Benz Customer Centre. As well as a warning in the instrument cluster, a window appears in the COMAND Display. There, a message actively indicates that a service is required; this message enables you to contact the Mercedes-Benz Customer Centre directly.

You will see the **Service <Service_name> is due soon: Would you like to make a workshop appointment?** message.

- To arrange a service appointment:** select **Call now** by turning COMAND Controller  and confirm with . After your confirmation, the vehicle data is sent via Mercedes-Benz Contact, and a Customer Centre employee personally deals with your appointment. The information is then sent to your desired service outlet. They will then contact with you within 24 hours to confirm the following details:
 - scope of service
 - length of stay
 - price
- To arrange a service appointment later:** select **Call later** and confirm with . The window is hidden, then reappears after a certain amount of time.
- To not arrange a service appointment:** select **No** and confirm with . The window is hidden and does not show this maintenance requirement again.

Mercedes-Benz emergency call system

Overview

The Mercedes-Benz emergency call system can help to decisively reduce the time between an accident and the arrival of emergency services at the site of the accident. It can also help locate an accident site in places that are difficult to see.

The emergency call can be made automatically or manually and is transmitted to the Europe-wide private Mercedes-Benz emergency call number. The vehicle position data is simultaneously transmitted by text message and DTMF to the Mercedes-Benz emergency call centre. The Mercedes-Benz emergency call centre transmits the vehicle position data to one of the Europe-wide public emergency call centres. In almost all countries, the voice connection can be made in the respective country's language. This allows measures for rescue, recovery or towing to a Mercedes-Benz Service Centre to be initiated quickly.

If the Mercedes-Benz emergency call system function is operational, you see the **SOS READY** display message in the basic telephone menu (▷ page 418).

Information on service availability in Europe (▷ page 415).

- i Note that manual emergency calls should only be used if you or others are in need of rescue, not e.g. in the event of a breakdown.

Service availability in Europe

The Mercedes-Benz emergency call system is available for your vehicle for 15 years after the initial date of production, if:

- it is equipped with COMAND Online
- it was originally produced for the European market

You can find more information on the regional availability of the Mercedes-Benz emergency

call system at http://www.mercedes-benz.com/connect_ecall.

Conditions

Equipment requirements

You need:

- a Bluetooth®-capable mobile phone which, if possible, supports the MAP profile (Message Access Profile) for sending text messages, or
- if the vehicle is equipped with permanently installed/SAP telephony, a SIM card or a suitable mobile phone

Functional requirements

The vehicle has GPS reception.

Check the following:

- COMAND Online is switched on
- when using the Bluetooth® interface, the mobile phone must be authorised for and connected with COMAND Online, and logged into a mobile phone network
Connecting a mobile phone (▷ page 381)
Reconnecting the mobile phone automatically (▷ page 385)

If your vehicle is equipped with permanently installed/SAP telephony, one of the following conditions must be fulfilled:

- in "telephone module with Bluetooth® (SAP profile)", a SIM card has been entered and is logged into the mobile phone network.
SAP (SIM Access Profile)
- a suitable SAP-capable mobile phone is connected to "telephone module with Bluetooth® (SAP profile)" via the SAP profile and is logged into the mobile phone network.
- if your vehicle is equipped with a mobile phone bracket: the mobile phone bracket is connected and the mobile phone is inserted (▷ page 386).

- **i** SAP telephony is described in separate operating instructions.

If the mobile phone is connected, you see the **SOS READY** display message in the basic tele-

phone menu in front of the name of the mobile phone (▷ page 418).

- **i** Further information on suitable mobile phones can be obtained from a Mercedes-Benz Service Centre or at <http://www.mercedes-benz.com/connect>.

- **i** Before using this function, make sure that your mobile phone contract:

- permits calls, text messages and roaming from both your country of residence and from abroad, and
- that these functions have been activated

Automatic emergency call

! If an emergency call has been made: provided the road and traffic conditions at the accident site allow it, remain in the vehicle until the voice connection with the operator at the emergency call centre has been established.

On the basis of the call, the operator can decide whether it is necessary to deploy rescue teams and/or the police to the accident site.

- **i** Depending on the severity of the accident, it can take between one and three minutes until the operator can speak with you.

REQUIREMENT: the ignition is switched on. If restraint systems have been triggered during an accident, the Mercedes-Benz emergency call system can automatically dial the Europe-wide private Mercedes-Benz emergency call number. Restraint systems include, for example, airbags or belt tensioners. The emergency call system can establish a voice connection between the vehicle occupants and the Mercedes-Benz emergency call centre.

The accident data is sent to the Mercedes-Benz emergency call centre by SMS and DTMF while the voice connection is operating. The accident data contains metre-precise GPS positioning data for the moment it is

sent, as well as the type of vehicle involved in the accident.

- i** If your vehicle is equipped with an SOS button in the overhead control unit, it flashes until the emergency call has been completed.
- i** It is not possible to end an automatic emergency call.
- i** In the following cases, you see a corresponding message on the COMAND display:
 - a connection to the Mercedes-Benz emergency call centre could not be made
 - nor has a call been automatically forwarded to the public emergency call centre
 In such circumstances, dial the emergency number **112** on your mobile phone.

Manual emergency call

- !** If an emergency call has been made: provided the road and traffic conditions at the accident site allow it, remain in the vehicle until the voice connection with the operator at the emergency call centre has been established.

On the basis of the call, the operator can decide whether it is necessary to deploy rescue teams and/or the police to the accident site.

Vehicles equipped with an SOS button



If your vehicle is equipped with the SOS button in the overhead control unit:

- ▶ Press and hold the SOS button for at least one second.
The manual emergency call is triggered. The indicator lamp in the SOS button flashes until the emergency call is concluded.

- i** In the following cases, you see a corresponding message on the COMAND display:
 - a connection to the Mercedes-Benz emergency call centre could not be made
 - nor has a call been automatically forwarded to the public emergency call centre
 In such circumstances, dial the emergency number **112** on your mobile phone.

In the address book

- ▶ Call up the address book (▷ page 406). The 1st entry, **Mercedes-Benz emergency call**, is highlighted.
- ▶ Press  the COMAND controller. The emergency call to the Mercedes-Benz emergency call centre is triggered.

- i** If you have accidentally made a manual emergency call, you can end it in the following ways:
 - by pressing the  button on COMAND Online
 - by pressing the  button on the multifunction steering wheel

- i** In the following cases, you see a corresponding message on the COMAND display:
 - a connection to the Mercedes-Benz emergency call centre could not be made
 - nor has a call been automatically forwarded to the public emergency call centre
 In such circumstances, dial the emergency number **112** on your mobile phone.

Transmitted data

Depending on how the data is transmitted (text message or DTMF), different data is transmitted to the Mercedes-Benz emergency call centre.

Text messages transmit the following:

- the vehicle's GPS position data
- the direction of travel
- the vehicle identification number

- a Mercedes-Benz Contact coding
- an indication of whether the call was triggered automatically or manually
- a time stamp
- the language settings on COMAND Online

DTMF sends a reduced data package that does not contain the vehicle identification number and time stamp.

Displays in the COMAND display

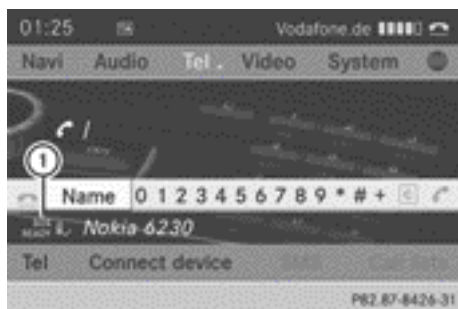

- ① Mercedes-Benz emergency call system is operational

If the Mercedes-Benz emergency call is available, you see the **SOS READY** display message in the basic telephone menu.

If a Mercedes-Benz emergency call is triggered either automatically or manually, you also see the **Mercedes-Benz emergency call active** display message.

If position and vehicle data are sent to the Mercedes-Benz emergency call centre, you see the **Mercedes-Benz emergency call Sending data** display message.

If the Mercedes-Benz emergency call connects with the Mercedes-Benz emergency call centre, you see the **Mercedes-Benz Emergency Call Connected** display message.

Online and Internet functions

Features of your COMAND Online

This Supplement describes all the standard and optional equipment for your COMAND

Online system, as available at the time of going to print. Country-specific differences are possible. Please note that your COMAND Online system may not be equipped with all the features described.

General notes

Conditions for access

WARNING

You must observe the legal requirements for the country in which you are currently driving when operating COMAND Online. If it is permitted to operate communications equipment while the vehicle is in motion, you must only operate it when road and traffic conditions permit. You may otherwise be distracted from the traffic conditions, cause an accident and injure yourself and others.

The COMAND Online Mercedes-Benz Apps and Internet access are available via the Bluetooth® interface or via the **data-enabled** MB SAP module. In order to use these functions in convenience telephony mode, the mobile phone has to be directly connected to COMAND Online via the Bluetooth® interface. In order to use the functions, the following conditions are necessary:

- The mobile phone supports the DUN Bluetooth® profile (**Dial-Up Networking**) and is connected to COMAND Online via the Bluetooth® interface (▷ page 381). The DUN Bluetooth® profile enables the mobile phone to establish a dial-up connection to the Internet.
- You need a valid mobile phone contract with a data option, to which the associated connection costs are charged.
- The access data of the connected mobile phone must be set in COMAND Online (▷ page 420).

- i** You can obtain more detailed information about suitable mobile phones on the Internet at <http://www.mercedes->

benz.com/connect or from your Mercedes-Benz Service Centre.

- i** If you use incorrect access data, additional costs may be incurred. This can happen when you use details that are different from the contract or details from another contract/data package.
- i** The availability of individual Mercedes-Benz Apps may vary depending on the country.
- i** The terms of use are shown when COMAND Online is used for the first time and then once a year thereafter. Only read and accept the terms of use when the vehicle is stationary.
- i** Internet pages cannot be shown while the vehicle is in motion.

Connection difficulties while the vehicle is in motion

The following could be the cause of call disconnection:

- insufficient GSM/UMTS network coverage
- the vehicle has moved into a GSM cell with no free channels
- the SIM card used is not compatible with the network available
- you are using a mobile phone with "Twin-card" and the mobile phone with the second SIM card is logged into the network at the same time.

Function restrictions

You will not be able to use the mobile phone, will no longer be able to use the mobile phone, or you may have to wait before using it, in the following situations:

- if the mobile phone is switched off
- if the "Bluetooth®" function is switched off in COMAND Online
- when the "Bluetooth®" function is switched off on the mobile phone if you are using Bluetooth® interface telephony

- if the mobile phone is not logged into a mobile phone network
- if either the mobile phone network or the mobile phone does not allow simultaneous use of a phone and an Internet connection.

- i** It is possible that you may not be able to receive calls when an Internet connection is active. This depends on the mobile phone and the mobile phone network used.

Roaming

When you are driving your vehicle in a different country and using COMAND Online and Internet functions, additional costs may be incurred (roaming fees). When you are in a different country, your SIM card must be enabled for data roaming. If your mobile phone network provider does not have a data roaming agreement with the roaming partner, it may not be possible to establish an Internet connection. Deactivate this function on your mobile phone if you want to avoid data roaming when you are in a different country.

Setting access data

Introduction

To use online and Internet functions, you need Internet access data for the connected mobile phone. You can obtain this from your mobile phone network provider.

A selected/manually set mobile phone network provider is only valid for the mobile phone connected when the selection/setting is made. The mobile phone network provider is set automatically upon reconnection.





- i** If you use incorrect access data, additional costs may be incurred. Incorrect data is, for example, details that are different from the contract or details from another contract/data package.
- i** If you are driving your vehicle in a different country and using the online and Internet

functions, you may incur additional charges (roaming fees).



- i** While initialising the mobile phone for the Internet connection, access data which is already on the mobile phone may be overwritten. You should therefore check the settings on the mobile phone (see the mobile phone operating instructions).
- i** Adjust the access data settings when the vehicle is stationary. You may otherwise be distracted from the traffic conditions, cause an accident and injure yourself and others.

Selecting/setting Internet access data

Calling up the list of network providers

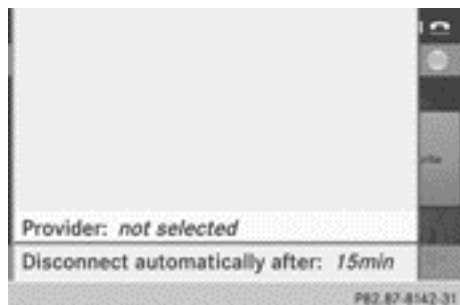
- ▶ Select the  symbol in the main function bar by sliding  and turning  the COMAND controller and press  to confirm. The carousel view appears.



- ▶ Select **Settings** by sliding  and turning  the COMAND controller and press  to confirm.

When you connect the mobile phone to COMAND for the first time (▶ page 381), there is no mobile phone network provider preset. **Provider:** is followed by the words **not selected**.

If a mobile phone is connected and a mobile phone network provider has been selected, the name of the mobile phone network is shown next to **Provider:**.

- ▶ Press  the COMAND controller. The list of mobile phone network providers appears.



List of mobile phone network providers (empty)

In order to set the access data of the mobile phone network provider you can:

- select predefined access data of the mobile phone network provider (▶ page 421)
- manually set the access data of the mobile phone network provider (▶ page 422)

Selecting access data of the mobile phone network provider



Searching for providers

- ▶ Select **Search for providers** in the mobile phone network providers list by turning $\left[\text{COMAND} \right]$ the COMAND controller and press $\left[\text{ENTER} \right]$ to confirm (▷ page 420). A list of countries appears.
- ▶ Select the country of your mobile phone network provider, e.g. **Germany**, and press $\left[\text{ENTER} \right]$ to confirm. The list of available mobile phone network providers appears.
- i** The access data for the mobile phone network provider is selected once for the mobile phone connected and is loaded again each time the mobile phone is connected (▷ page 420).

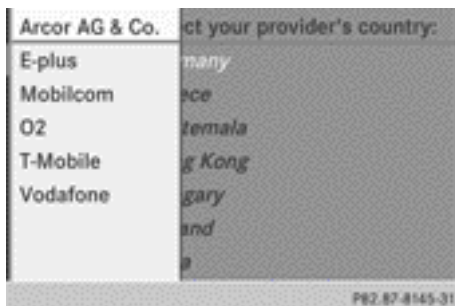

- i** You must set the access data of the mobile phone network provider who provides the SIM card and the associated data package (access settings) for the connected mobile phone. The access data remains the same if you are in a different country

(roaming). The access data of another network is **not** selected.

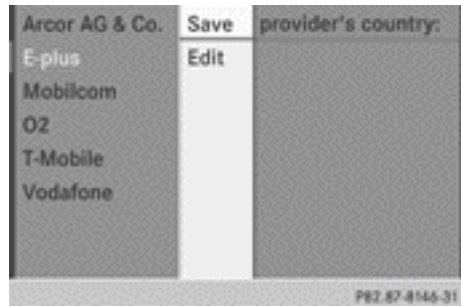

There are mobile phone network providers who offer multiple access data. This depends on the data package used, for example.





The mobile phone network provider only has one access setting

- ▶ Select the mobile phone network provider by turning $\left[\text{COMAND} \right]$ the COMAND controller and press $\left[\text{ENTER} \right]$ to confirm. A menu appears.
- ▶ **To check preset access data:** select **Edit** and confirm with $\left[\text{ENTER} \right]$. The list of access data appears (▷ page 422). Check the access data. Description of access data.
- ▶ **If the access data is correct:** press the $\left[\text{RESET} \right]$ reset button or the $\left[\text{RESET} \right]$ symbol and press $\left[\text{ENTER} \right]$ to confirm. You can now accept the access data of the mobile phone network provider.
- ▶ Select **Save** and press $\left[\text{ENTER} \right]$ to confirm. The list of mobile phone network providers appears; the access data of the provider has been accepted.
- ▶ **To edit the access data:** proceed as described in "Manually enter the access data" section (▷ page 422). When you confirm the edited access data, the list of mobile phone network providers appears and displays the selected provider.

If, after selecting a mobile phone network provider, several access settings are displayed:

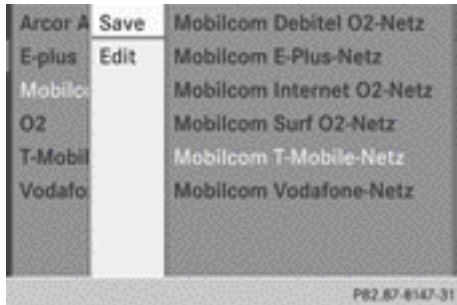

- ▶ Select the appropriate access setting by turning  the COMAND controller and press  to confirm. A menu appears.



- ▶ **To check access settings:** select **Edit** and press  to confirm.

The list of access data appears ([▷ page 422](#)).

Check the access data. Description of access data.

- ▶ **If the access data is correct:** press the  reset button or the  symbol and press  to confirm.

You can now accept the access data of the mobile phone network provider.

- ▶ Select **Save** and press  to confirm. The list of mobile phone network providers appears; the access data of the provider has been accepted.

- ▶ **To edit the access data:** proceed as described in "Manually setting the access data of the mobile phone network provider" ([▷ page 422](#)).

When you confirm the edited access data, the list of mobile phone network providers appears and displays the selected provider.





List of mobile phone network providers with the selected provider

The currently selected access settings (• dot in front of the entry) are used for the connected mobile phone.

- ▶ **To return to the carousel view:** press the  button twice.

or

- ▶ Press  the COMAND controller and then the  button.

Manually setting the access data of the mobile phone network provider



List of access data (new provider)

Calling up the list of access data

► Confirm **Create new provider** in the list of mobile phone network providers by pressing  the COMAND controller. The list of access data appears. The standard name **Provider <x>** is automatically entered into the **Provider:** field. You can now make the entries.

i The access data of the mobile phone network provider is set once for the connected mobile phone.

Explanation of the access data

Input field	Meaning
Provider:	Name of the provider to be displayed in the list of mobile phone network providers. The name can be freely selected. The standard entry is Provider <x> .
Ph. number:	Access number for establishing the connection i The access number depends on the mobile phone used. For GSM/UMTS mobile phones, *99***1# is used as a standard.
Access point:	APN network access point (Access Point Name) You can obtain this information from your mobile phone network provider. i Entry is not necessary for all mobile phone network providers and mobile phones.

Input field	Meaning
User ID:	The user identification can be obtained from your mobile phone network provider. i Entry is not necessary for all mobile phone network providers.
Password:	The password can be obtained from your mobile phone network provider. i Entry is not necessary for all mobile phone network providers.
DNS address:	The DNS addresses (Domain Name Service) can be negotiated automatically or entered manually. The required information can be obtained from your mobile phone network provider. i Most mobile phone network providers support the Automatic function. If you selected the Manual option, you are usually required to enter a DNS address.
DNS 1: DNS 2:	Fields for entering the DNS server addresses manually. The address can be obtained from your mobile phone network provider.

Entering access data

► In the list of access data, confirm the **Provider** input field by pressing  (> page 422).
An input menu appears.



- ▶ Enter the provider (▷ page 298).
- ▶ **To enter the phone number:** in the list of access data, select the **Te1. Number:** input field by sliding ↓ or turning ↻ the COMAND controller and press ⏹ to confirm. The input menu for the phone number appears.

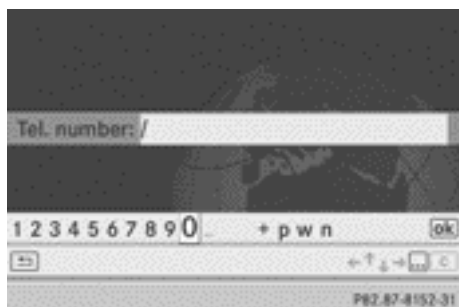

- ▶ Enter the telephone number.
- ▶ **To enter the access point:** in the list of access data, select the **Access point** input field and press ⏹ to confirm.
- ▶ Enter the access data.
- ▶ **To enter the user ID:** in the list of access data, select the **User ID** input field and press ⏹ to confirm.
- ▶ Enter the user ID.
- ▶ **To enter the password:** in the list of access data, select the **Password** input field and press ⏹ to confirm.
- ▶ Enter the password.

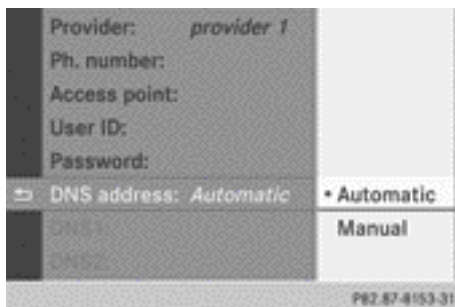

- ▶ **To set the DNS address:** select **Auto-****matic** or **Manua1** with the COMAND controller and press ⏹ to confirm. **Automatic** negotiates the DNS addresses automatically. **Manua1** uses the entries in DNS 1 and DNS 2.

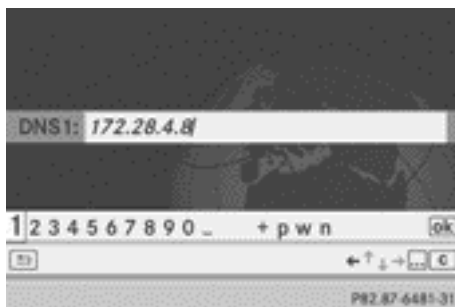

Entering the DNS1

Entering the example DNS

- ▶ After selecting **Manua1**, select the **DNS1** input field with the COMAND controller and press ⏹ to confirm.
- ▶ For example, enter **172.28.4.81**.

Internet access data for other mobile phones

If the access data is already available in the list of mobile phone network providers, you can use it for additional mobile phones.

The following prerequisites are required for this:

- the additional mobile phone must be connected.
 - the access data must apply to the mobile phone contract of the currently connected mobile phone.
- ▶ Select a provider in the list of mobile phone network providers by turning **⏏** the COMAND controller and press **⏏** to confirm (▷ page 421).
After you select the provider, the list of mobile phone network providers is closed. The selected provider is entered.
- ▶ **To call up the carousel view:** slide **⏏** the COMAND controller.

Managing access data of the mobile phone network provider

Overview

The access data of the mobile phone network provider can be:

- edited
 - copied, edited and accepted for a new provider name
 - deleted
- i** Changes that you make to the access data of a mobile phone network provider apply to all mobile phones that use this access data.
- i** When the Internet connection is active, you cannot edit or delete the access data of the currently set mobile phone network provider.

Editing the access data

- ▶ Select a provider in the list of mobile phone network providers by turning **⏏** the COMAND controller (▷ page 421).
- ▶ Select the symbol to the right of the entry by sliding **⏏** the COMAND controller and press **⏏** to confirm.

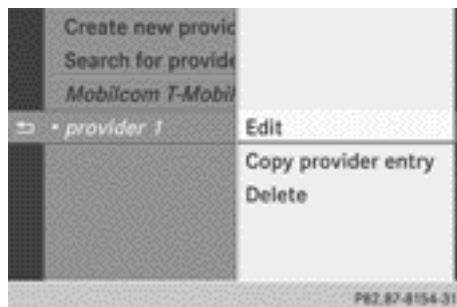



- ▶ Confirm **Edit** by pressing **⏏**.
The access data is displayed.
- ▶ Edit the access data. A description of the entry can be found under "Manually setting the access data of the mobile phone network provider" (▷ page 422).

Saving access data under a new provider name

- ▶ Select a provider in the list of mobile phone network providers by turning **⏏** the COMAND controller (▷ page 421).
- ▶ Select the symbol to the right of the entry by sliding **⏏** the COMAND controller and press **⏏** to confirm.
- ▶ Confirm **Copy provider entry** by pressing **⏏**.
The access data is displayed.
- ▶ Edit the access data. A description of the entry can be found under "Making entries" in the "Manually setting the access data of the mobile phone network provider" section (▷ page 422).

Deleting the access data of the mobile phone network provider



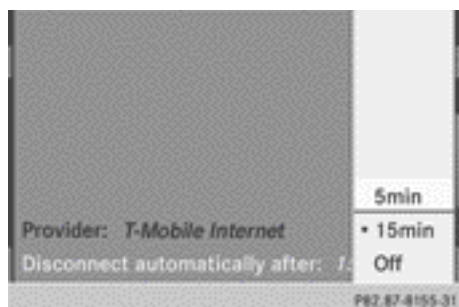

- ▶ Select a provider in the list of mobile phone network providers by turning **⏏** the COMAND controller (▷ page 421).
- ▶ Select the symbol to the right of the entry by sliding **⏏** the COMAND controller and press **⏏** to confirm.

- ▶ Confirm **Delete** by pressing . A prompt appears asking whether you wish to delete the access data.
- ▶ Select **Yes** or **No** and press  to confirm. If you select **Yes**, the access data is deleted and the name of the provider is removed from the list of mobile phone network providers. If you select **No**, the process will be cancelled.

Selecting the length of time for automatic disconnection from the Internet



After a preset time has elapsed during which neither the online functions nor the Internet have been used, COMAND automatically disconnects from the Internet.

- ▶ Select **Settings** in the carousel view  by sliding  the COMAND controller and press  to confirm.
- ▶ Select **Disconnect automatically after:** and press  to confirm. The • dot indicates the current setting.
- ▶ Select **5 min**, **15 min** or **Off** and press  to confirm. **Off** switches the function off.









An active Internet connection is identified by the double arrows on the top right of the display.

Establishing/ending the connection

Establishing the connection



Preconditions for establishing a connection can be found under "General notes" ( page 418).

- ▶ **1st option:** select the  icon in the main function bar by sliding  and turning  the COMAND controller and press  to confirm. The carousel view appears.
- ▶ Turn  or slide  the COMAND controller until the **Mercedes-Benz Apps** panel or a favourite is brought to the front, if these have been previously created ( page 449).
- ▶ **Option 2:** enter a web address ( page 444).



- ▶ For both options, press the COMAND controller.

The Internet connection is established. An active Internet connection is identified with symbol . The example shows a menu in the Google™ Local Search function (▶ page 428).

- ▶ **To cancel the connection:** while the connection is being established, confirm **Cancel** by pressing .

or

- ▶ Press the button on COMAND Online or on the multifunction steering wheel.

- i** If a phone call is made at the same time as the active Internet connection, the symbol is displayed in . The Internet connection remains active depending on the mobile phone and mobile phone network used.

Ending the connection

- ▶ Press the button on COMAND Online or on the multifunction steering wheel.

or

- ▶ Select the scissors symbol on the bottom right of the carousel view and press to confirm.

- i** If the mobile phone Internet connection is cancelled, COMAND Online tries to reconnect. You should therefore always close the connection on COMAND Online or via the multifunction steering wheel.

Google™ Local Search

Calling up the local search menu



- ▶ Select the icon in the main function bar by sliding and turning the COMAND controller and press to confirm.

The carousel view appears.

- ▶ Bring the **Mercedes-Benz Apps** panel to the front by turning the COMAND controller and pressing to confirm. The Mercedes-Benz Apps menu appears.
- ▶ Bring the **Google Local Search** panel to the front and press to confirm.
- ▶ **To exit the menu:** select **Back** by sliding and turning the COMAND controller and press to confirm.

Using search results



- ▶ Select an entry in the list of search results by turning **⏪** the COMAND controller and press **⏩** to confirm. A menu appears.

- ▶ **To show the detailed view:** confirm **Details** by pressing **⏩** the COMAND controller. The address of the selected entry is displayed.



- ▶ **To use a search result as the destination:** select **Navigate to** by turning **⏪** the COMAND controller and press **⏩** to confirm. You then switch to navigation mode and can start route calculation (▷ page 321).

- ▶ **i** The search result is stored in the "Last destinations" memory at the same time (▷ page 362). You can take the destination from this memory and save it permanently in the destination memory (▷ page 360).

- ▶ **To call up a destination:** select **Call** with the COMAND controller and press **⏩** to confirm.

You then switch to the telephone function and make the call (▷ page 391).

- ▶ **i** The menu item is greyed out if there is no phone number available.

- ▶ **To import a destination:** select **Import** with the COMAND controller and press **⏩** to confirm.

You can choose whether you want to save the POI as a personal POI on the SD memory card or in the address book.

- ▶ **i** If there is no SD memory card in the slot, the **As personal POI** menu item is greyed out.

- ▶ Insert the SD memory card (▷ page 463).

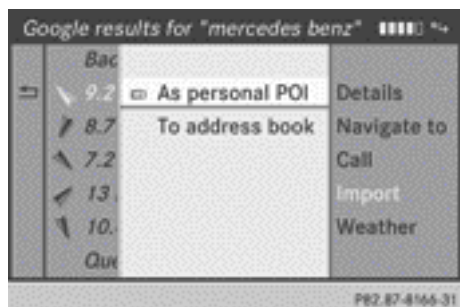

- ▶ **To save as a personal POI:** confirm **Save as personal POI** by pressing **⏩** the COMAND controller.

The entry is saved as a personal POI on the SD memory card.

- ▶ **i** You can use a personal POI in navigation mode for route calculation (▷ page 338).

If the personal POI is saved on the SD memory, you can also use it for route calculation in another vehicle.



- ▶ **To save to the address book:** select **To address book** by turning **⏪** the COMAND controller and press **⏩** to confirm.

The entry is stored in the address book.

Popular searches



This function allows you to search using predefined search criteria.

- ▶ Bring **Popular searches** in the local search menu to the front by turning  (the COMAND controller and press  to confirm.
A menu displays the available search criteria.





Example: popular Google™ searches

- ▶ Select the search criteria and press  to confirm.
- ▶ Proceed as described in the "Selecting the search position" section (▷ page 428). If the vehicle is stationary, the search results can be supplemented manually, e.g. "Hotel Adler".

Search history



This function offers you all the previous search queries.

- ▶ Bring **Search history** in the local search menu to the front by turning  the COMAND controller and press  to confirm.
The previous search queries are shown with the most recent at the top.



- ▶ Select the search criteria and press  to confirm.
- ▶ Proceed as described in the "Selecting the search position" section (▷ page 428). If the vehicle is stationary, the search results can be supplemented manually, e.g. "Hotel Adler".

Destination/route download

Introduction

You can send destinations and routes from Google™ maps to the server and download these via this function. You can use the des-

tinations and routes for route guidance and save them for further use.

Step 1: sending destinations/routes to the server







- ▶ Call up the website for Google™ Maps on the Internet.
- ▶ Select the destination.
- ▶ Select "Mercedes-Benz" as the company entry.
- ▶ Select identification for the download (vehicle identification number or e-mail address).
- ▶ Confirm "Send" on the Google™ Maps website.
The destinations/routes are sent to the server.

i The vehicle identification number (VIN) is preset at the factory. You can change the identification and enter your e-mail address instead (▷ page 442).

The availability of the Google™ Maps function is country-dependant.

Step 2: downloading destinations/routes from the server

Proceed as follows to use destinations/routes that have been sent to the server:

- ▶ Select the  icon in the main function bar by sliding  and turning  the COMAND controller and press  to confirm.
The carousel view appears.
- ▶ Bring the **Mercedes-Benz Apps** panel to the front by turning  the COMAND controller and pressing  to confirm.
The Mercedes-Benz Apps menu appears.



- ▶ Bring the **Destination/route download** panel to the front and press  to confirm.

i With **Exit**, you quit the destination/route download.

With **Options**, you set the options for the destination/route download (▷ page 442).

- ▶ Confirm the **Destination/route download** panel by pressing .

Available routes and destinations are shown in the list.





You can save up to 20 routes and 50 destinations for your vehicle on the server and display these in the list. If you send further routes or destinations to the server, the existing entries are deleted from the list.

- i** The routes/destinations sent from Google™ maps to the server are automatically deleted from there after seven days.

Step 3: using destinations/routes

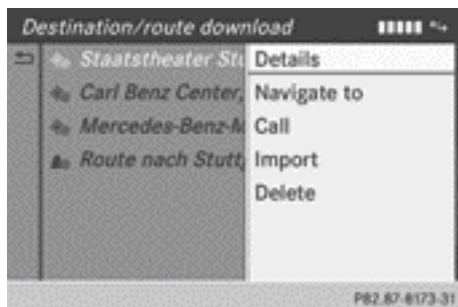
Calling up a menu



- ▶ Select an entry in the list by turning  the COMAND controller and press  to confirm. A menu appears.

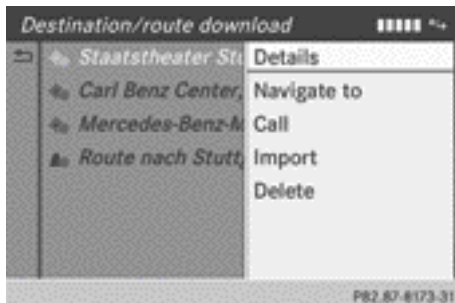

Displaying details



Example for start and destination



Example of a destination address

- ▶ Confirm **Details** in the menu by pressing  the COMAND controller. The route or destination is displayed.
- ▶ **To call up a POI:** confirm the entry by pressing .
- i** You can use the function if:
 - a mobile phone is connected (> page 381)
 - the destination address contains a telephone number

Using as the destination

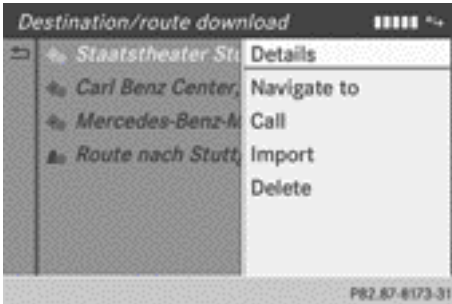

- ▶ Select **Navigate to** in the menu by turning **[OK]** the COMAND controller and press **[ENTER]** to confirm.

You then switch to navigation mode and can start route calculation (▷ page 321).

- i** A route can only be stored as a personal POI on an SD memory card or taken directly for route calculation (▷ page 433).

Calling up the destination

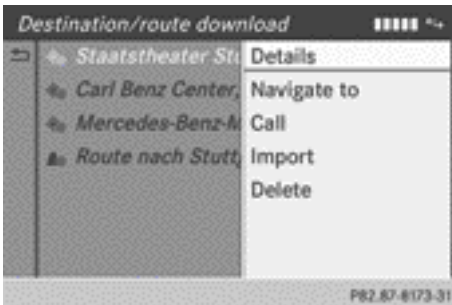

- ▶ Select **Call** in the menu by turning **[OK]** the COMAND controller and press **[ENTER]** to confirm.

You then switch to the telephone function and make the call (▷ page 391).

Importing a destination/route

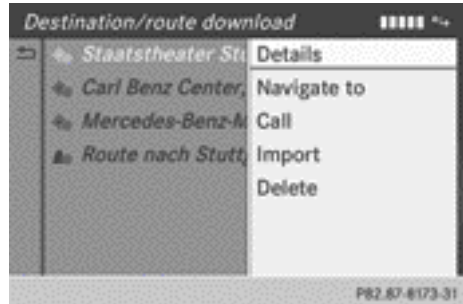

When importing, you can choose whether you want to save the destination as a personal POI on an SD memory card or in the address book. You can only save routes as personal POIs to an SD memory card, but not in the address book.

- ▶ Select **Import** in the menu with the COMAND controller and press **[ENTER]** to confirm.

- i** If there is no SD memory card in the slot, the **As Personal POI** menu item is greyed out.

- ▶ Insert the SD memory card (▷ page 463).

- ▶ **To save as a personal POI:** confirm **Save as personal POI** by pressing **[ENTER]** the COMAND controller. The entry is saved as a personal POI on the SD memory card.

- i** You can use a personal POI in navigation mode for route calculation (▷ page 338). You can also use a personal POI in another vehicle for route calculation.

- ▶ **To save to the address book:** select **To Address Book** by turning **[OK]** the COMAND controller and press **[ENTER]** to confirm. The entry is stored in the address book.

Deleting a destination/route from the server

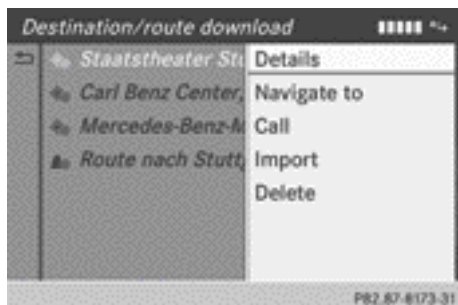

- ▶ Select an entry in the list by turning the COMAND controller and press to confirm.
- ▶ Select **Delete** and press to confirm. A query appears asking whether the destination or the route should be deleted.
- ▶ Select **Yes** or **No** and press to confirm. If you select **Yes**, the destination or route is deleted. If you select **No**, the process will be cancelled.

Weather

Introduction

COMAND can receive weather forecasts anywhere in the world via online connection and display them in an information chart (current day, 5-day forecast) or in the weather map. The weather map can display the following weather data with symbols:

- hazard icons (e.g. storms, slippery conditions)
- precipitation radar (e.g. rain, snow)
- atmospheric pressure conditions
- temperatures
- cloud cover
- wind direction and speeds

Switching the weather display on/off

- ▶ **To switch on:** select the icon in the main function bar by sliding and turning the COMAND controller and press to confirm. The carousel view appears.
- ▶ Turn the COMAND controller until **Mercedes-Benz Apps** is brought to the front and press to confirm. The Mercedes-Benz Apps carousel view appears.



- ▶ Turn the COMAND controller until **Weather** is brought to the front and press to confirm. The information chart shows the current weather at the current vehicle position (factory setting). You can change the default view and the default location in the Options menu (▶ page 440).



You see the following information:

- the time of the current weather report
- the current temperature

- information on the weather (e.g. cloudy, rain)
- the maximum daytime temperature
- the minimum daytime temperature
- the probability of rain
- the forecast for the current day (three time intervals)

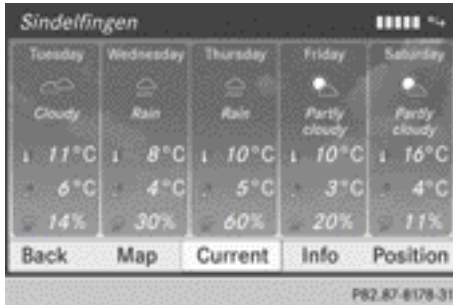

- ▶ **To switch to a five-day forecast:** confirm **5-day** by pressing . The information chart displays the forecast for the next five days in the currently selected location.
- ▶ **To return to the current weather information:** confirm **Current** by pressing .
- ▶ **To switch off:** press the back button. or
- ▶ Select **Back** by turning the COMAND controller and press to confirm. Irrespective of the option chosen, the carousel view will appear.

Displaying additional information

In addition to the current temperatures, you can also display information such as humidity and air quality (if the information is available).

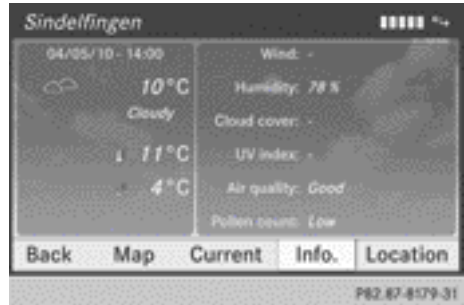

- ▶ Select **Info** in the information chart by turning the COMAND controller and press to confirm. The information chart displays information for the selected location.

Selecting the location

Introduction

You can select the following options for the weather forecast:

- the current vehicle position
- the destination
- a winter sports area
- a location anywhere in the world



You can select the location in the information chart (option 1 (▷ page 435)) or in the map (option 2) (▷ page 437). Weather information is supplied by the nearest weather station.

Option 1: selecting the location in the information chart

- ▶ Select **Position** in the information chart by turning the COMAND controller and press to confirm. A menu appears.



► **To select the current vehicle position:** confirm **Current position** by pressing .

► **To select the destination:** select **Near destination** by turning  the COMAND controller and press  to confirm.

i If a route has been calculated, you can select **Near destination** (► page 321). The menu item is otherwise greyed out.

► **To select a winter sports area:** select **In winter sports areas** in the menu and press  to confirm. A list of countries appears.



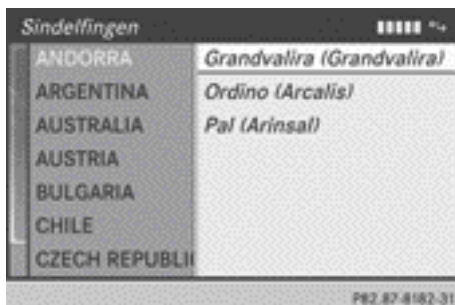

► Select a country, e.g. **ANDORRA**, and press  to confirm. The available winter sports areas are displayed.

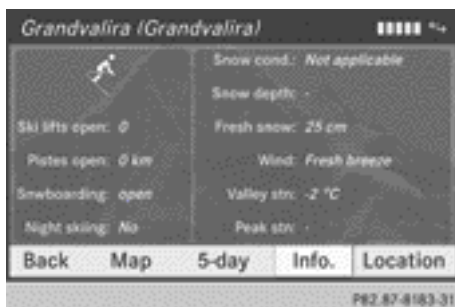

► Select a winter sports area from the menu and press  to confirm. The information chart shows information on:

- type of skiing
- snow conditions
- temperatures



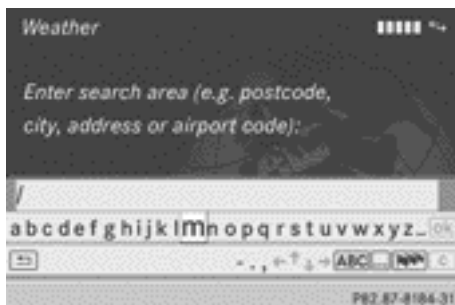

► **To select the location:** select **Other location** in the menu by turning  the COMAND controller and press  to confirm. An input menu appears.



- ▶ Enter the search area. Character entry (▷ page 300).
The information chart with the weather forecast appears when the search area has been entered.



Entry	Example
Postcode	10117
City	Berlin
Address	Unter den Linden
Airport code	TXL (Tegel Airport)

Option 2: selecting the location in the weather map







- ▶ Call up the weather map and move to the desired location (▷ page 437).
- ▶ Press  the COMAND controller. The menu bar is shown.
- ▶ Press  the COMAND controller again and confirm **Display weather**.
The information chart displays the current weather for the selected location.

Weather map

Calling up the weather map

- ▶ Select **Map** in the information chart by turning  the COMAND controller and press  to confirm.
The map appears in a scale of 20 km.





- ▶ **To display the crosshair:** slide  the COMAND controller.
- ▶ **To scroll the weather map:** slide ,  or  the COMAND controller. The weather map moves in the corresponding direction under the crosshair.
- ▶ **To change the map scale:** as soon as you turn  the COMAND controller, the scale bar appears.
- ▶ Turn  until the desired scale is set.

- i** The data is downloaded again from the server for these functions. This can delay the display of the weather map.

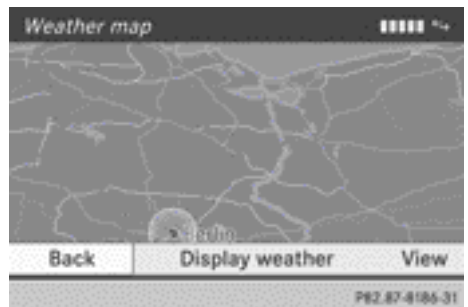
Showing/hiding the menu in the weather map



- ▶ **To show:** press  the COMAND controller in the weather map.
- ▶ **To hide:** slide up  the COMAND controller.

Switching to the weather information display in the map

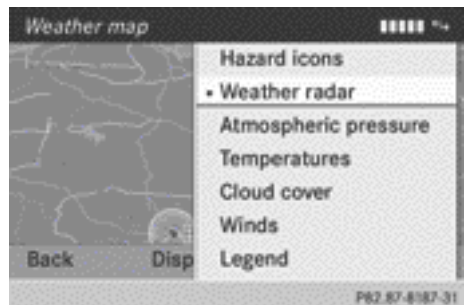

- ▶ Display the menu on the weather map (▷ page 437).
- ▶ Select **View** by turning **⏏** the COMAND controller and press **⏏** to confirm.

Weather characteristic	Display in the map
Hazard icons	Shows warnings
Weather radar	Displays the rain radar as a coloured area on the map
Atmospheric pressure	Displays air pressure with isobars and as a coloured area on the map
Temperatures	Displays the temperatures
Cloud cover	Displays the clouds
Winds	Displays wind direction with an arrow and wind speed with colouring

i The hazard icon display is preset in the factory. This presetting can be changed in the Options menu (▷ page 440).

- ▶ Select a weather characteristic by turning **⏏** the COMAND controller and press **⏏** to confirm.
The **•** dot indicates which weather characteristic is currently displayed on the map. You can select one weather characteristic at a time.

Legend

- ▶ Display the menu on the weather map (▷ page 437).
- ▶ Select **View** by turning **⏏** the COMAND controller and press **⏏** to confirm.
- ▶ Select **Legend** and press **⏏** to confirm.
The legend is displayed in accordance with the currently selected weather characteristic.



Legend for warnings

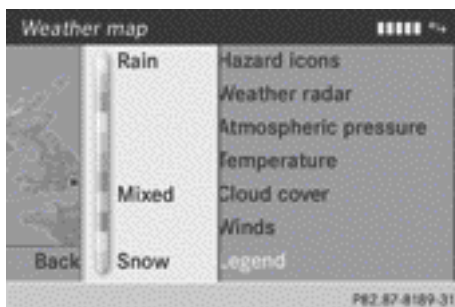

Legend for precipitation radar

- ▶ **To switch back to the information chart:** display the menu on the weather map (▷ page 437)

- ▶ Select **Display weather** and press **⏏** to confirm.

Memory functions

Storing a location in the memory

You can save locations that are called up frequently in ten preset positions (0, 1 – 9).

- ▶ Select the location (▷ page 435).
- ▶ Press and hold a number key.
When the location is saved, the number of the selected preset comes before the name of the place in the caption.

Selecting a location from the memory

- ▶ **Quick select:** when the weather display (COMAND Online) is switched on and an

entry is available, press a number key, e.g.



The information chart appears and displays the weather information.

- ▶ **From the weather memory:** select **Position** in the information chart by turning $\left[\odot \right]$ the COMAND controller and press \odot to confirm.
- ▶ Select **Presets** and press \odot to confirm.
- ▶ Select a preset position that has an entry by turning $\left[\odot \right]$ the COMAND controller and press \odot to confirm.
The information chart appears and displays the weather information.

Options

Introduction

You can select options for the following Mercedes-Benz Apps on COMAND Online:

- Local search (▷ page 439)
- Weather (▷ page 440)
- Destination/route download (▷ page 442)

You can reset the selected options to the default settings (▷ page 443).

Calling up the Options menu

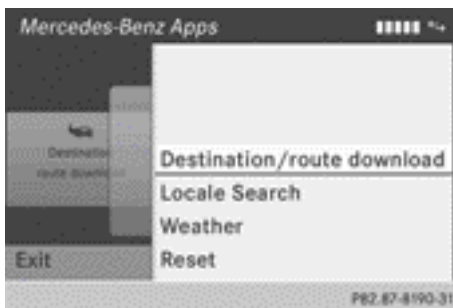

Options menu

- ▶ Select the  icon in the main function bar by sliding $\uparrow \odot$ and turning $\left[\odot \right]$ the

COMAND controller and press \odot to confirm.

The carousel view appears.

- ▶ Bring the **Mercedes-Benz Apps** panel to the front by turning $\left[\odot \right]$ the COMAND controller and pressing \odot to confirm.
- ▶ Select **Options** by sliding $\odot \updownarrow$ and turning $\left[\odot \right]$ the COMAND controller and press \odot to confirm.

Selecting options for the local search

Setting the search radius

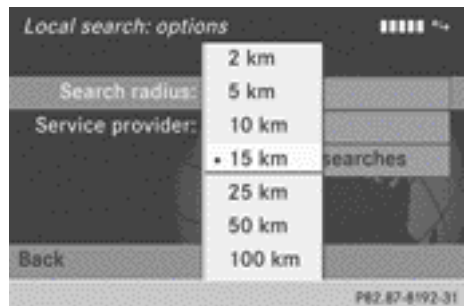
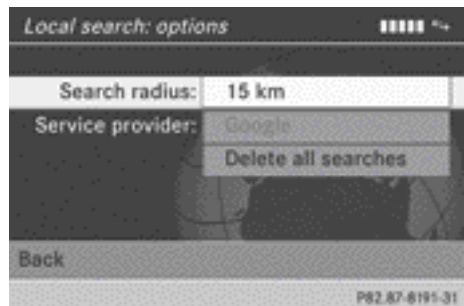

- ▶ Select **Local Search** in the Options menu by turning $\left[\odot \right]$ the COMAND controller and press \odot to confirm.
The menu shows the current settings.
- ▶ Confirm the entry after **Search radius:** by pressing \odot .
The • dot indicates the currently selected search radius.

- ▶ Select an entry by turning **Ⓜ** the COMAND controller and press **Ⓜ** to confirm. The selected setting is accepted.
- ▶ **To exit the menu:** select **Back** by turning **Ⓜ** the COMAND controller and press **Ⓜ** to confirm.

Selecting a service provider

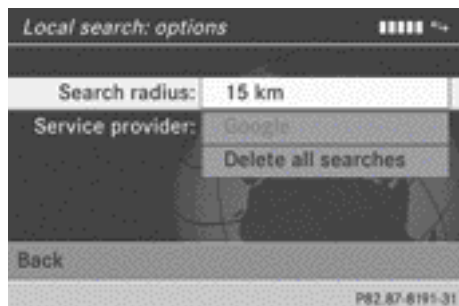

- ▶ Select **Local Search** in the Options menu by turning **Ⓜ** the COMAND controller and press **Ⓜ** to confirm. The menu shows the current settings.
- ▶ Select the entry after **Service provider:** by turning **Ⓜ** the COMAND controller and press **Ⓜ** to confirm. The **•** dot indicates the currently selected service provider.

- i** If the entry is greyed out, you cannot select the service provider.
- ▶ Select an entry and press **Ⓜ** to confirm. The selected service provider is accepted.
- ▶ **To exit the menu:** select **Back** by turning **Ⓜ** the COMAND controller and press **Ⓜ** to confirm.

Deleting/saving search queries

- ▶ Select the **Delete all searches** entry by turning **Ⓜ** the COMAND controller and press **Ⓜ** to confirm. A prompt appears, asking whether you really wish to delete the search queries.

- ▶ Select **Yes** or **No** and press **Ⓜ** to confirm. If you select **Yes**, the search queries are deleted. If you select **No**, the process will be cancelled.

Selecting options for the weather display

Setting the default view

You can specify which view is called up after activating the weather display (▷ page 434).

You can make the following settings:

- current weather
- five-day forecast
- info view
- last view

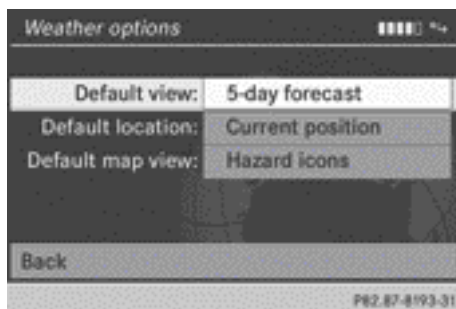

- ▶ Select **Weather** in the options menu by turning **Ⓜ** the COMAND controller and press **Ⓜ** to confirm (▷ page 439). The menu shows the current settings.
- ▶ Confirm the entry after **Default view:** by pressing **Ⓜ**. The **•** dot indicates the currently selected default view.
- ▶ Select an entry by turning **Ⓜ** the COMAND controller and press **Ⓜ** to confirm. The selected view is accepted.
- ▶ **To exit the menu:** select **Back** by turning **Ⓜ** the COMAND controller and press **Ⓜ** to confirm.

Setting the default location

You can make the following settings:

- current position
- current destination
- presets

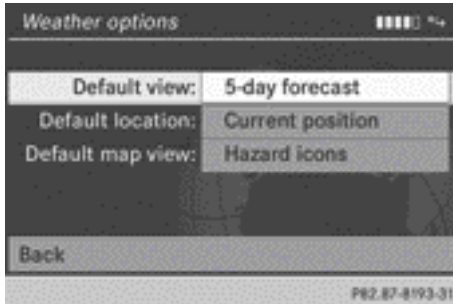

- ▶ Select **Weather** in the options menu by turning **[Ⓞ]** the COMAND controller and press **[Ⓞ]** to confirm (▷ page 439). The menu shows the current settings.
- ▶ Select the entry after **Default location**: by turning **[Ⓞ]** the COMAND controller and press **[Ⓞ]** to confirm. The **•** dot indicates the currently selected default location.
- ▶ Select an entry by turning **[Ⓞ]** the COMAND controller and press **[Ⓞ]** to confirm. The selected location is accepted.
- ▶ **To exit the menu**: select **Back** by turning **[Ⓞ]** the COMAND controller and press **[Ⓞ]** to confirm.

Selecting weather data for the map view

The weather map can display the following weather data:

- hazard icons (e.g. storms, slippery conditions)
- precipitation radar (e.g. rain, snow)
- atmospheric pressure conditions
- temperatures
- cloud cover
- wind direction and speeds

You can select one feature each for the map view.

The availability of weather information is country-dependent.

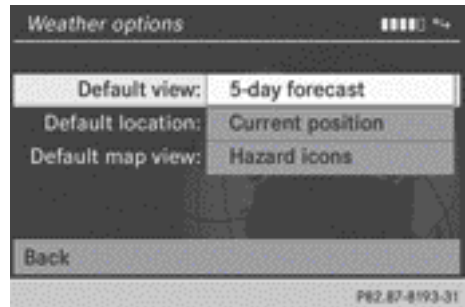

- ▶ Select **Weather** in the options menu by turning **[Ⓞ]** the COMAND controller and press **[Ⓞ]** to confirm (▷ page 439). The menu shows the current settings.
- ▶ Select the entry after **Default map view**: by turning **[Ⓞ]** the COMAND controller and press **[Ⓞ]** to confirm. The **•** dot indicates the currently selected feature.
- ▶ Select an entry and press **[Ⓞ]** to confirm. The selected feature is accepted.
- ▶ **To exit the menu**: select **Back** by turning **[Ⓞ]** the COMAND controller and press **[Ⓞ]** to confirm.

Setting options for destination/route download

Specifying the ID for the download

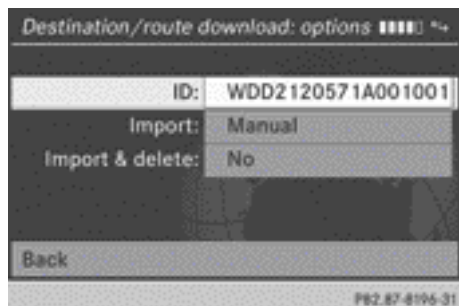

You can replace the vehicle identification number (ID) with your e-mail address. The vehicle identification number is usually entered.

- ▶ Select **Destination/route download** in the Options menu by sliding $\uparrow \odot \downarrow$ the COMAND controller and press \odot to confirm (▷ page 439). The menu shows the current settings.
- ▶ Confirm the entry next to **ID:** by pressing \odot . An input menu appears.
- ▶ Enter an e-mail address. Character entry (▷ page 298).
- ▶ After entry, select ok and press \odot to confirm. The e-mail address is entered in the menu. An e-mail will be sent to your e-mail address shortly afterwards. You must confirm it

within 48 hours. Otherwise, your previous ID will continue to be used.

- ▶ To complete the settings, check your mailbox and follow the link in the e-mail.
- ▶ **To exit the menu:** select **Back** by turning $\{\odot\}$ the COMAND controller and press \odot to confirm.

Setting the type of import

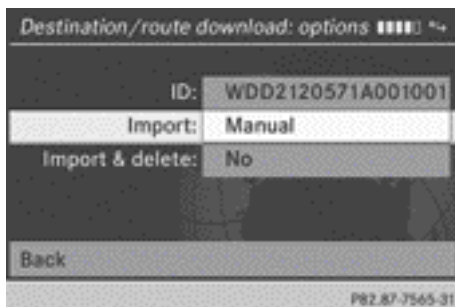



You can choose between manual and automatic importing.

- ▶ Select the entry after **Import:** by turning $\{\odot\}$ the COMAND controller and press \odot to confirm. The \bullet dot indicates the current setting.
- ▶ Select **Manual** or **Automatic** and press \odot to confirm. The setting is accepted.
- ▶ **To exit the menu:** select **Back** by turning $\{\odot\}$ the COMAND controller and press \odot to confirm.

Deleting/keeping POIs after they have been imported to the server











- ▶ Select the entry after **Import & delete:** by turning $\{\odot\}$ the COMAND controller and press \odot to confirm. The \bullet dot indicates the current setting.
- ▶ Select **Yes** or **No** and press \odot to confirm. The setting is accepted. **Yes** deletes the POIs after importing to the server. **No** does not delete the POIs on the server.

- ▶ **To exit the menu:** select **Back** by turning  the COMAND controller and press  to confirm.

i Routes and destinations are automatically deleted on the server after seven days.

Resetting adjustments

The reset function resets all Mercedes-Benz Apps settings to the factory settings. After resetting, Google™ can only send routes and destinations to the vehicle identification number (ID) once you have activated your e-mail address again (▷ page 442).







- ▶ Select the  icon in the main function bar by sliding  and turning  the COMAND controller and press  to confirm.
The carousel view appears.
- ▶ Bring the **Mercedes-Benz Apps** panel to the front by turning  the COMAND controller and pressing  to confirm.
- ▶ Select **Options** by sliding  and turning  the COMAND controller and press  to confirm.
- ▶ Select **Reset** and press  to confirm.
A prompt appears asking whether you really wish to reset.
- ▶ Select **Yes** or **No** and press  to confirm.
If you select **Yes**, the settings are reset.
If you select **No**, the process will be cancelled.

Additional services

Mercedes-Benz Mobile Website



The COMAND Online functions contain the Mercedes-Benz Mobile Website as a predefined favourite.





- ▶ Select the  icon in the main function bar by sliding  and turning  the COMAND controller and press  to confirm.
The carousel view appears.
- ▶ Bring the **Mercedes-Benz Mobile Website** panel to the front by turning  the COMAND controller and pressing  to confirm.
The Mercedes-Benz home page appears.

i You cannot delete the **Mercedes-Benz Mobile Website** panel.



Further Mercedes-Benz Apps

You can call up additional Mercedes-Benz Apps, such as Facebook, or Google™ services, such as Street View or Panoramio, here.



The following examples show how to call up a Mercedes-Benz App, for example Facebook, and generally how to call up Google™ services.

► **To call up Facebook:** select the  symbol in the main function bar by sliding  and turning  the COMAND controller and press  to confirm.

The carousel view appears.

► Bring the **Mercedes-Benz Apps** panel to the front by turning  the COMAND controller and pressing  to confirm.

The Mercedes-Benz Apps menu is displayed.

► Select **Facebook** by turning  the COMAND controller and press  to confirm.

The Facebook homepage appears.

► **To call up Google™ services:** this is done through Google™ Local Search (▷ page 430).

 Facebook is a social networking website. This App allows you to log in from your vehicle and use Facebook's many functions.

Google™ Street View allows you to view streets in 360-degree panoramas.

Google™ Panoramio expands Google Local Search to include photos at the selected position.

Internet





Display restriction

Internet pages cannot be shown while the vehicle is in motion.

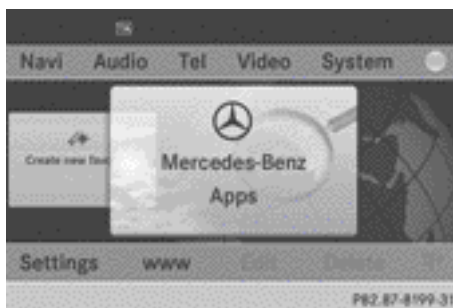
Calling up a website

Calling up the carousel view



► Select the  icon in the main function bar by sliding  and turning  the COMAND controller and press  to confirm.

The carousel view appears.



You can now enter a web address (option 1 (▷ page 444)) or select it in the carousel view (option 2 (▷ page 445)).

To select in the carousel view, you must first create favourites (▷ page 449).

Option 1: entering the web address

You can enter the web address using either the character bar or the number keypad (▷ page 300).

► Call up the carousel view (▷ page 444).

► Select **www** by sliding  and turning  the COMAND controller and press  to confirm.

An input menu appears.



- ▶ **To enter using the character bar:** enter the web address in the input line. Character entry (▷ page 298).

As soon as the first letter has been entered in the input line, a list appears below it. The list shows web addresses that begin with the letters you have entered and web addresses that have already been called up.





The list is empty the first time you call it up.



- ▶ **To enter characters using the number pad:** press the number keys in rapid succession.





The character appears when the key is pressed. The first available letter is highlighted. Enter the character using the character bar (▷ page 300).



- ▶ After entering the web address, select the  symbol by turning  or sliding  the COMAND controller and press  to confirm. The website is called up.

- ▶ **To select a web address in the list:** slide  the COMAND controller in the input menu with character bar. The list is activated.





- ▶ Select the web address by turning  or sliding  the COMAND controller and press  to confirm. The web address is entered in the input line.
- ▶ Press  the COMAND controller. The website is called up. The **Establishing data connection to <provider name>...** message appears.

Option 2: selecting favourites

You must create at least one favourite in the carousel view for this function (▷ page 449).









- ▶ Call up the carousel view (▷ page 444).
- ▶ In the carousel view, bring a favourite to the front by turning  or sliding  the COMAND controller and press  to confirm. The website is called up.



Navigating the website

Overview

Step	Activity
▶ Turn  the controller.	Navigates from one item that can be selected (e.g. link, text field or selection list) to the next and highlights the respective element on the website.
Sliding the controller:	Moves the pointer on the page.
▶ Left or right 	
▶ Up or down 	
▶ Diagonally 	
▶ Press  the controller.	Calls up the menu or opens the selected item.
▶ Press  .	Calls up the previous page.
▶ Press  .	Closes the Internet browser. If several windows are open, the current window is closed.



Example: highlighting an item that can be selected





- ▶ Turn  COMAND Controller.
A button is highlighted in the example.

Example: entering text



- ▶ Select an input line by turning  the COMAND controller and press  to confirm.
The character bar appears.





- ▶ Enter the text using the character bar or the number keypad. Character entry (▷ page 298).
- ▶ If the text has been entered, select the  symbol by turning  the COMAND controller and press  to confirm. The text has now been entered.

Menu functions

Calling up a menu



- ▶ **To call up the shortcut:** highlight the selectable item on the page by turning  the COMAND controller and press  to confirm.





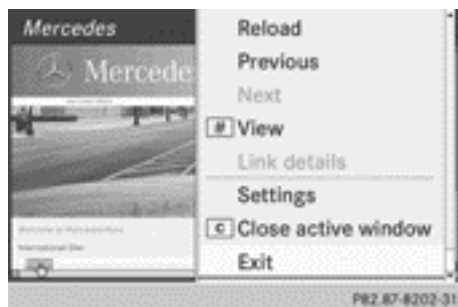

Start of menu



End of menu

- ▶ **To call up the entire menu:** when the shortcut is displayed, slide  the COMAND controller downwards.

or



- ▶ Select a free area on the website by sliding ,  or  the COMAND controller and press  to confirm.

Opening

Opens the website to the selectable item.

- ▶ Call up the menu (▷ page 447).
- ▶ Confirm **Open** by pressing  the COMAND controller.

Entering a URL

- ▶ Call up the menu (▷ page 447).
- ▶ Select **Enter URL** by turning  or sliding  the COMAND controller and press  to confirm.
- ▶ Enter a web address (URL) (▷ page 444).

Calling up the previous website

- ▶ Call up the menu (▷ page 447).
- ▶ Select **Previous** by turning **⏪** or sliding **↑** the COMAND controller and press **⏹** to confirm.

Calling up the next website

- ▶ Call up the menu (▷ page 447).
- ▶ Select **Next** by turning **⏩** or sliding **↓** the COMAND controller and press **⏹** to confirm.

View

You can use this function to:

- position a selection window on websites that are larger than the display
- select a window that is already open
- ▶ Call up the menu (▷ page 447).
- ▶ Select **View** by turning **⏪** or sliding **↑** the COMAND controller and press **⏹** to confirm.

or

- ▶ Press the **#** key on the number keypad.

- i** You cannot use the **#** key if a phone call is being made.

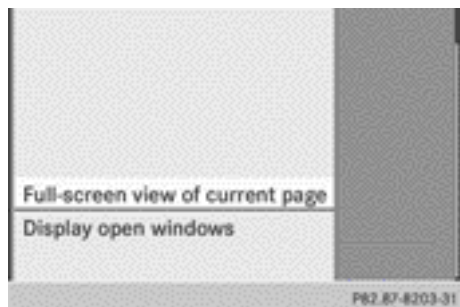

- ▶ **To position the selection window:** confirm **Full-screen view of current page** by pressing **⏹** the COMAND controller. A selection window appears on the website.



- ▶ Slide **←**, **↑**, or **↖** the COMAND controller and position the selection window on the website.
- ▶ Press **⏹** the COMAND controller. The selected section is enlarged.
- ▶ **To display and select open windows:** select **Display open windows** by turning **⏪** or sliding **↑** the COMAND controller and press **⏹** to confirm. The carousel view appears.



- ▶ Press **⏹** the COMAND controller. The website is displayed.

Exiting the menu

- ▶ Call up the menu (▷ page 447).
- ▶ Select **Exit** by turning **⏪** or sliding **↑** the COMAND controller and press **⏹** to confirm. The Internet browser is closed. If other windows are opened in the background, another prompt appears.

Other menu functions

Open in a new window

You can open up to five windows simultaneously.

- ▶ Call up the menu (▷ page 447).
- ▶ Select **Open in new window** by turning or sliding the COMAND controller and press to confirm.
- ▶ **To select a window:** select **View** and press to confirm.
- ▶ Select the website in the carousel view by turning or sliding the COMAND controller and press to confirm.

Add to favourites

Adds the current website to the favourites. The website can then be called up using the carousel view. You can save up to 20 favourites in the carousel view.

- ▶ Call up the menu (▷ page 447).
- ▶ Select **Add to favourites** by turning or sliding the COMAND controller and press to confirm.
The following message appears: **The page has been added as a favourite.**

Display favourites

- ▶ Call up the menu (▷ page 447).
- ▶ Select **Display favourites** by turning or sliding the COMAND controller and press to confirm.
The favourites are shown in the carousel view.

Further information on favourites (▷ page 449).

Reloading a website

- ▶ Call up the menu (▷ page 447).
- ▶ Select **Reload** by turning or sliding the COMAND controller and press to confirm.

Close active window

- ▶ Call up the menu (▷ page 447).
 - ▶ Select **Close active window** by turning or sliding the COMAND controller and press to confirm.
- or
- ▶ Press the button to the right of the COMAND controller.

You cannot use the button if a phone call is being made.

Displaying the complete web address of the selected link

- ▶ Call up the menu (▷ page 447).
- ▶ Select **Link details** by turning or sliding the COMAND controller and press to confirm.
The web address (URL) appears.
- ▶ Press the COMAND controller and close the display.

Settings

The settings are described in a separate section (▷ page 452).

Favourites

Introduction

Favourites are frequently visited websites.

You have the following options for creating a favourite:

- in the carousel view (▷ page 449)
- via the menu item **Add to favourites** (▷ page 449)

Before creating a favourite in the carousel view, you must first close active connections (▷ page 427).

You can select and edit favourites that you have created.

Creating favourites

Creating favourites in the carousel view

- ▶ Call up the carousel view (▷ page 444).

- ▶ Bring the **Create new favourite** panel to the front by turning $\left[\odot \right]$ or sliding $\leftarrow \odot \rightarrow$ the COMAND controller.



- ▶ Press \odot the COMAND controller. An input menu appears.



- ▶ Enter the web address (URL) and name using either the character bar or the number keypad. Character entry (▶ page 298)
- ▶ Select the $\boxed{\text{ok}}$ symbol and press \odot to confirm. The favourite has been created.

Adding a favourite via the menu

- ▶ When a website is displayed, call up the menu.
- ▶ Select **Add to favourites** in the menu and press \odot to confirm (▶ page 449).

Selecting favourites

- ▶ Call up the carousel view (▶ page 444).

- ▶ Select the favourite in the carousel view by turning $\left[\odot \right]$ or sliding $\leftarrow \odot \rightarrow$ the COMAND controller and press \odot to confirm. The favourite is opened.

Editing favourites

Editing favourites in the carousel view

- ▶ Call up the carousel view (▶ page 444).
- ▶ Select **Edit** by sliding $\odot \downarrow$ and turning $\left[\odot \right]$ the COMAND controller and press \odot to confirm. An input menu appears.



- ▶ Enter the web address (URL) and name using either the character bar or the number keypad (▶ page 298).

Editing favourites in the Favourites menu

- ▶ Call up the menu (▶ page 447).
- ▶ Select **Display favourites** by turning $\left[\odot \right]$ the COMAND controller and press \odot to confirm. The favourite is displayed.
- ▶ Press \odot the COMAND controller. The Favourites menu appears.



Favourites menu

- ▶ Select **Edit** by turning $\left\{ \odot \right\}$ or sliding $\uparrow \odot \downarrow$ the COMAND controller and press \odot to confirm.

or

- ▶ Press the $\boxed{*}$ key on the number keypad. An input menu appears.



- ▶ Enter the web address (URL) and name using either the character bar or the number keypad. Character entry (\triangleright page 298).

Other functions in the Favourites menu

Opening current favourites

- ▶ Call up the Favourites menu (\triangleright page 450).
- ▶ Confirm **Open** by pressing \odot the COMAND controller.

Opens the current favourites in a new window.

Opening in a new window

- ▶ Call up the Favourites menu (\triangleright page 450).
- ▶ Select **Open in new window** by turning $\left\{ \odot \right\}$ or sliding $\uparrow \odot \downarrow$ the COMAND controller and press \odot to confirm.

Calling up details

- ▶ Call up the Favourites menu (\triangleright page 450).
- ▶ Select **Details** by turning $\left\{ \odot \right\}$ or sliding $\uparrow \odot \downarrow$ the COMAND controller and press \odot to confirm.

or

- ▶ Press the $\boxed{\#}$ key on the number keypad. The detailed display appears.

Exiting

- ▶ Call up the Favourites menu (\triangleright page 450).
- ▶ Select **Exit** by turning $\left\{ \odot \right\}$ or sliding $\uparrow \odot \downarrow$ the COMAND controller and press \odot to confirm.

or

- ▶ Press the \leftarrow back button on the left next to the COMAND controller. The Favourites menu closes.

Deleting favourites

Deleting favourites in the carousel view

- ▶ Call up the carousel view (\triangleright page 444).
 - ▶ Select **Delete** by sliding $\odot \downarrow$ and turning $\left\{ \odot \right\}$ the COMAND controller and press \odot to confirm. A query appears.
 - ▶ Select **Yes** and press \odot to confirm. The favourite is deleted.
- If you select **No**, the process will be cancelled.

Deleting favourites in the Favourites menu

- ▶ Select **Delete** by turning **⏏** or sliding **↑** **⏏** **↓** the COMAND controller and press **⏏** to confirm.

or

- ▶ Press the **[c]** button to the right of the COMAND controller.
The favourite is deleted.

Settings

Settings menu

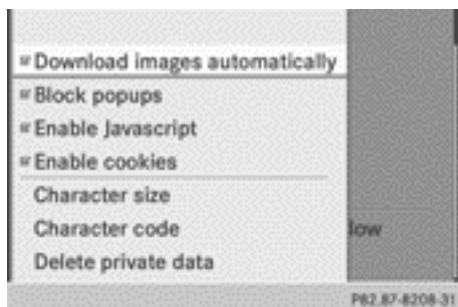

- ▶ Call up the menu (▶ page 447).
- ▶ Select **Settings** by turning **⏏** or sliding **↑** **⏏** **↓** the COMAND controller and press **⏏** to confirm.

You can activate/deactivate the following settings:

- **Download images automatically**

It may take some time to download the contents of websites that contain a large number of images. Therefore, it may be useful to deactivate this option.

- **Block popups**

Popups are windows (usually with advertisements) which are displayed automatically when you call up a website. You can block these displays.

- **Enable Javascript**

Javascript makes it possible to display and interact with dynamic content on the website.

- **Enable cookies**

Some websites save information in small text files (cookies) in COMAND Online. You can determine whether cookies may be stored.

- **Character size**

You can select the font size which is used when displaying the website.

- **Character code**

You can select a different character set here, e.g. if the characters of a website appear distorted.

- **Delete private data**

Deletes data which has been saved by the browser during Internet use.

Changing settings

- ▶ Select a setting by turning **⏏** the COMAND controller and press **⏏** to confirm.
Switch the setting on or off .
- ▶ Select **Character size** or **Character code** by turning **⏏** or sliding **↑** **⏏** **↓** the COMAND controller and press **⏏** to confirm.
- ▶ Select a setting using the COMAND controller and press **⏏** to confirm.

i If you change the settings, the websites may not be displayed correctly.

Deleting private data

- ▶ Select **Delete private data** and press **⏏** to confirm.
A menu appears.



- ▶ Select the setting by turning or sliding the COMAND controller and press to confirm.

The • dot in front of an entry indicates which setting is active.

or

- ▶ Select **Delete all data on exiting** and press to confirm. Switch the setting on or off .

Option	Function
All	Deletes all private data.
Cache	Deletes data in the temporary storage.
Cookies	Deletes cookies that are created by websites which you have called up.
Websites visited	Deletes all websites visited (path).
<input checked="" type="checkbox"/> Delete all data on exiting	If this function is activated <input checked="" type="checkbox"/> , all private data is deleted when you exit the Internet browser.

- i** If you reset COMAND Online to the factory settings (reset function), these settings are deleted (▷ page 308).

Calling up the carousel view and closing the Internet browser

- ▶ **To call up the carousel view:** press the back button for longer than two seconds.
- ▶ **To close the Internet browser:** press the back button again for longer than two seconds.

Audio

Features of your COMAND Online

This Supplement describes all the standard and optional equipment for your COMAND Online system, as available at the time of going to print. Country-specific differences are possible. Please note that your COMAND Online system may not be equipped with all the features described.

Radio mode and DAB radio mode

Introduction

- i** Portable electronic devices in the vehicle may seriously impair radio and DAB radio reception.

DAB (Digital Audio Broadcasting) is an optimised digital transmission standard designed for the mobile reception of radio transmissions. Several programmes are combined into so-called ensembles and transmitted on a single frequency. Digital radio stations can be transmitted nationally, regionally or locally.

Some stations only transmit programmes at certain times. If you have selected a station that has been subsequently removed from the ensemble, it will no longer be received. You will continue to receive the other programmes in the ensemble. You will then need to select a different programme.

- i** DAB cannot be received everywhere in Europe.

Switching to radio mode and DAB radio mode

Switching on with the function button

- ▶ Press the function button. The radio or DAB radio display appears. **Radio mode:** you will hear the last station played on the last waveband selected.

DAB radio mode: you will hear the last station played from the last ensemble selected.

- ① Repeatedly pressing the **RADIO** function button switches between the FM, MW, SW and LW wavebands in that order. It then calls up DAB radio mode. Pressing the button again takes you back to FM radio mode.

Switching on with the audio menu

- ▶ Select **Audio** in the main function bar by sliding **↑** and turning **⌚** the COMAND controller and press **⏵** to confirm.

If radio mode or DAB radio mode was the last mode selected, it is now active.

If another audio mode is switched on, you can now switch to radio mode in the audio menu.

You can select DAB radio mode in the radio display.

- ▶ Select **Audio** by sliding **↑** the COMAND controller and press **⏵** to confirm. The audio menu appears.

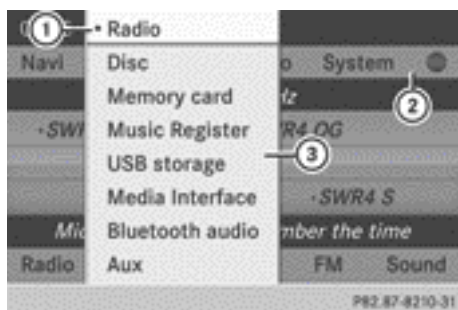

- ① Current audio operating mode
- ② Main function bar
- ③ Audio menu

- ▶ Select **Radio** by turning **⌚** the COMAND controller and press **⏵** to confirm.

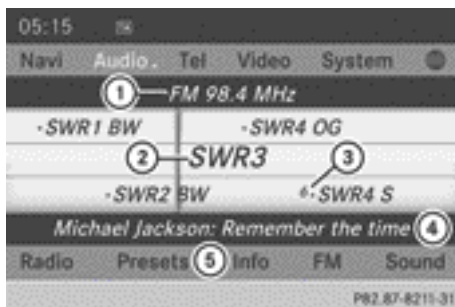

FM radio display

- ① Waveband and frequency of the selected station
- ② Station name or station frequency of the selected station
- ③ Memory position of a station
- ④ Radio text plus display (if available)
- ⑤ Radio mode menu bar

- ▶ **To switch on DAB radio mode:** select **FM** in the radio display by sliding **⊙** and turning **⌚** the COMAND controller and press **⏵** to confirm.



- ▶ Select **DAB** and press **⏵** to confirm.

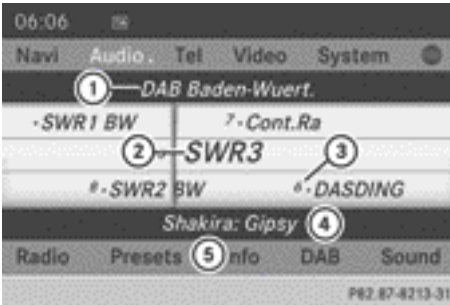

DAB radio display

- ① Name of the ensemble to which the selected station belongs
- ② Name of the selected station
- ③ Memory position of a station
- ④ Radio text plus display (if available)
- ⑤ DAB radio mode menu bar

i If reception is poor (e.g. in tunnels or mountain valleys), affected stations are shown in grey. Playback of the currently selected station is interrupted. As soon as the reception quality is adequate, displays and playback return to normal.

Switching wavebands

Option 1

You can switch the radio between the FM, MW, LW and SW wavebands.

- ▶ Press the **RADIO** function button repeatedly until the desired waveband is selected.

Option 2

- ▶ Select **FM**, **DAB**, **MW**, **SW** or **LW** in the radio display by sliding $\odot \updownarrow$ and turning $\left\{ \odot \right\}$ the COMAND controller and press \odot to confirm.
- ▶ Select a waveband and press \odot to confirm. You will hear the last station played on the selected waveband.

i In the MW, LW and SW wavebands, COMAND Online shows the station frequency instead of the station name.

Ensembles

An ensemble consists of multiple radio programmes. Every ensemble is transmitted in a certain area (national, regional or local) in the same way as a traditional AM/FM radio station.

Switching to an FM station automatically

If the reception of a DAB radio station deteriorates, COMAND Online automatically changes to the corresponding FM station. For this to happen, the following conditions must be met:

- the FM station's frequency is available.
- the **Channel fix** (\triangleright page 458) menu item is switched off.

i If you want to use this function, do **not** switch to FM radio mode.

If there is no reception, the display shows the **No reception** message.

Selecting a station

Selecting a station from the station list

The station list is available in the FM waveband and in DAB radio mode.

Radio mode: the station list contains all the stations that can currently be received and is sorted alphabetically. For stations without a programme service, the list shows the frequency instead of the name.

DAB radio mode: the station list contains stations from all ensembles that can currently be received. It shows the current programme and a programme preview if the station operator supports this function. The station list is sorted alphabetically.

- ▶ **Quick select:** turn $\left\{ \odot \right\}$ or slide $\leftarrow \odot \rightarrow$ the COMAND controller while the display/selection window is active.

or

- ▶ Press the **[[<<]]** or **[[>>]]** button. The needle jumps to the left or right.

- ▶ **To make a selection in the station list:** select **Radio** by sliding $\odot \downarrow$ and turning $\left\{ \odot \right\}$ the COMAND controller and press \odot to confirm.
- ▶ Confirm **Station List** by pressing \odot . The station list appears.

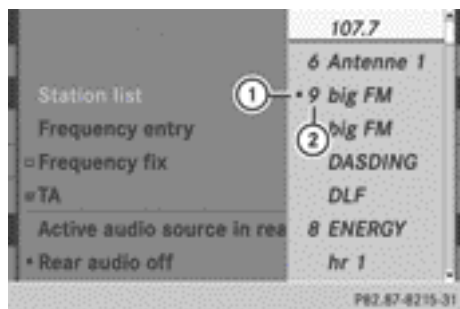

Example: radio mode

- ① Currently selected station
- ② Memory slot in station presets

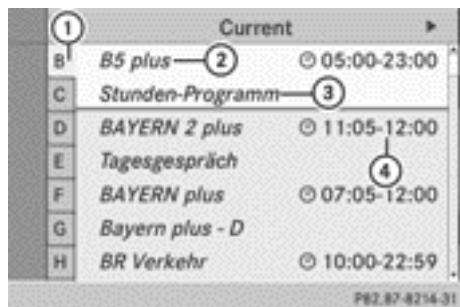

Example: DAB radio mode

- ① Alphabetical browser
 - ② DAB radio station
 - ③ Current programme
 - ④ Start and end times of the programme
- ▶ Select the station by turning $\left\{ \odot \right\}$ the COMAND controller and press \odot to confirm.
 - ▶ **To call up the programme preview:** slide $\odot \rightarrow$ the COMAND controller. The next programmes are shown for the displayed DAB radio stations.
 - ▶ Switch back by sliding $\odot \leftarrow$.

- ▶ **To activate the alphabetical browser:** slide $\odot \leftarrow$ the COMAND Controller.
- ▶ Select the initial letter of the desired station name by turning $\left\{ \odot \right\}$ the COMAND controller. The station list changes to display the appropriate stations.
- ▶ Switch back by sliding $\odot \rightarrow$.
- ▶ To select a station using the multifunction steering wheel, see the separate vehicle Owner's Manual.

Selecting a station using the station search function

In radio mode, the station search function is only available for the MW, LW and SW wavebands.

- ▶ Press the \lll or \ggg button. Station search scans up or down and stops at the next station.
- ▶ To select a station using the multifunction steering wheel, see the separate vehicle Owner's Manual.

Selecting stations via the station presets

- ▶ **Quick setting:** press a number key, e.g. $\boxed{2}$.
- ▶ **Directly in the station presets:** select **Presets** by sliding $\odot \downarrow$ and turning $\left\{ \odot \right\}$ the COMAND controller and press \odot to confirm.
 - or
 - ▶ Press \odot the COMAND controller when the display/selection window is active. The station preset memory appears. The
 - dot indicates under which preset the currently selected station is stored.
 - ▶ Select a station by turning $\left\{ \odot \right\}$ and press \odot to confirm.
 - or
 - ▶ Press a number key, such as $\boxed{2}$.

- ▶ To select a station using the multifunction steering wheel, see the separate vehicle Owner's Manual.

Selecting stations by entering the frequency manually

This function is available in radio mode.

- ▶ **Option 1:** press the button.
- ▶ **Option 2:** select **Radio** in the radio display by sliding and turning the COMAND controller and press to confirm.
- ▶ Select **Frequency entry** and press to confirm.
Irrespective of the option chosen, an input menu will appear.
- ▶ Enter a frequency using the number keys. COMAND Online sets the frequency entered.

Waveband	Frequency
FM (VHF)	87.5 – 108.0 MHz
MW (medium wave)	531 – 1620 kHz
SW (short wave)	5800 – 6250 kHz
LW (long wave)	153 – 282 kHz

- You can only enter currently permitted numbers.
- If you enter a frequency in the MW, SW or LW wavebands that is outside the frequency range, COMAND Online sets the next lower frequency.

Storing a station

Storing stations manually

There are ten presets available for each waveband as well as for DAB radio mode.

- ▶ **Quick save:** press and hold a number key, e.g. , until you hear a tone. The station is stored.

- ▶ **Directly in the station presets:** press the COMAND controller when the display/selection window is active.

or

- ▶ Select **Presets** by sliding and turning the COMAND controller and press to confirm.
In both cases, the station presets appear. The dot indicates under which preset the currently selected station is stored.



Station presets in DAB radio mode

- ▶ Select a preset by turning the COMAND controller and press and hold until you hear a tone. The station is stored under the preset.

Storing stations automatically

This function automatically stores stations with adequate reception under the presets. The search starts at the lowest frequency. COMAND Online stores any stations found, beginning with preset 1. The storing process ends once the highest frequency has been reached or once 10 stations have been found. Any stations stored manually under the presets will be lost. COMAND Online may not occupy all memory slots when storing.

- ▶ **Option 1:** press the COMAND controller when the display/selection window is active.
- ▶ Select **Autostore** in the presets by turning the COMAND controller and press to confirm.

- ▶ **Option 2:** select **Presets** by sliding and turning the COMAND controller and press to confirm.
- ▶ Select **Autostore** and press to confirm. In both cases, COMAND Online searches for stations that can be received. You will see a message to this effect. The available channels are automatically stored in the preset positions.
- ▶ **To cancel storing:** select **Cancel** and press to confirm.

Radio Data System (RDS)

General notes

The Radio Data System (RDS) provides inaudible additional information in the FM waveband. The system consists of a listening receiver and a monitoring receiver.

The monitoring receiver permanently scans the FM waveband and collects certain data from all receivable stations. This includes, for instance, reception quality and RDS data such as programme names and alternative frequencies. COMAND Online stores the data and constantly updates the memory. The audio receiver is therefore able to switch automatically to an alternative frequency with a better signal.

- RDS only functions for stations which transmit RDS data.

Switching RDS on/off

You can use the **Frequency fix** (radio mode) or **Station fix** (DAB mode) functions to prevent COMAND Online from switching between the alternative frequencies of a station. This is useful, for example, when the same content is broadcast with a time delay, or when there is interference on one of the frequencies.

- ▶ Select **Radio** in the radio display by sliding and turning the COMAND controller and press to confirm.

- ▶ Select **Frequency fix** or **Station fix** by turning the COMAND controller and press to confirm. Depending on the previous status, switch **Frequency fix** on or off .

Traffic Programme

Note

Many FM stations transmit traffic announcements (TA). You can also hear these in DAB radio mode.

Switching traffic announcements on/off

- ▶ **Option 1:** select **Radio** by sliding and turning the COMAND controller and press to confirm.

The tick next to **TA** indicates that traffic announcement reception is switched on. You see the **TA** symbol in the status bar.

- ▶ Select **TA** and press to confirm. **TA** is switched on or off, depending on the previous status.
- ▶ **Option 2:** on COMAND Online or on the multifunction steering wheel, press and hold the button until the **TA** symbol lights up or goes out in the status bar.

A warning tone sounds.

Once traffic announcements have been switched on, COMAND Online selects an RDS station.

Traffic Programme is retrieved from:

- the currently selected FM station
- an RDS station from the network of the currently selected FM station
- the RDS station with the best reception quality

When traffic announcements are switched on, a traffic announcement will interrupt the audio signal from the currently activated audio or video source.

- Telephone conversations and navigation announcements are not interrupted.

A display message appears in the display in all audio operating modes.

Interrupting a traffic announcement

During a traffic announcement:

- ▶ On COMAND Online or on the multifunction steering wheel, briefly press the button.

or

- ▶ Press the , or button on the multifunction steering wheel. COMAND Online switches back to the audio source that was selected before the announcement. Any subsequent new announcements will continue to interrupt the audio source.

Radio text/radio text plus

Messages in the display

The function is available in FM mode and in DAB radio mode.

Radio text/radio text plus consists of additionally transmitted data, e.g. information on the current programme, which is displayed in the COMAND display.

If the station supports radio text plus, the artist and track are displayed.



Radio text plus (display: artist and track)

- ▶ **To show/hide the artist and track:** select **Radio** in the radio display by sliding

and turning the COMAND controller and press to confirm.

- ▶ Select **Display artist and track** and press to confirm. Switch the display on or off .

- ▶ **To display radio text:** select **Info** in the corresponding radio display by sliding and turning the COMAND controller and press to confirm. If the station supports radio text and information is available, the system displays it.



Radio text (display for additional information on programme)

- ▶ **To return to the radio display:** confirm **Info** by pressing .
- ▶ Slide the COMAND controller up.

Audio CD/DVD and MP3 mode

Important safety notes

WARNING

COMAND Online is classified as a Class 1 laser product. Never open the housing. There is a risk of damage to the eyes due to exposure to invisible laser radiation if you open the casing, or if the casing is faulty or damaged. COMAND Online does not contain any parts that can be serviced by the user. For safety reasons, all maintenance work must be carried out by qualified aftersales technicians.

WARNING

Only when the vehicle is stationary should you:

- load a disc
- eject a disc

There is a risk of being distracted from the road and traffic conditions if this is done while the vehicle is in motion.

Inserting/ejecting CDs/DVDs

Notes

If the CD/DVD has a printed side, this must face upwards when the CD/DVD is inserted. If neither side is printed, the side to be played should face downwards. CDs/DVDs with copy protection may not be able to be played by the system.

i If a medium contains other files in addition to music files, the loading time before the first track starts to play may be longer.

Inserting a disc into the single DVD drive

- ▶ Press the  eject button. If there is a disc already inserted, it will be ejected.
- ▶ Take the disc out of the slot.
- ▶ Insert a disc into the slot. The disc is drawn in and playback starts if the disc has been inserted correctly and it is a permissible type.

Ejecting a disc from the single DVD drive



- ▶ Press the  eject button.
- ▶ Take the disc out of the slot. If you do not take the disc out of the slot, it is drawn in again automatically after a short while and reloaded.

Inserting discs into the DVD changer

The DVD changer has a fixed magazine with six trays.

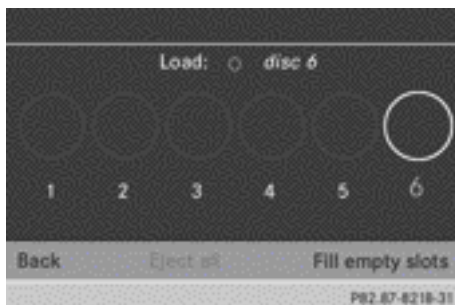
- ▶ **To insert a CD/DVD into the magazine tray:** press the  load/eject button. A menu shows the current load status of the magazine trays. The last tray selected is identified by a red digit.



- ▶ Select a magazine tray to be filled by turning  the COMAND controller and press  to confirm.

or

- ▶ Press a number key, e.g. . The DVD changer switches to the selected magazine tray. You see the **Please wait...** message. You then see the **Please insert disc <x>** message.



- ▶ Insert a disc into the disc slot with the printed side facing upwards. The DVD changer loads the disc into the selected magazine tray. The **Loading disc <x>...** message appears.

i It may take some time for the disc to be loaded, depending on the type of disc. If no disc is inserted for approximately 20 sec-

onds, the display returns to the magazine menu.

The DVD changer plays the disc if:

- it has been inserted correctly.
- it is a permissible type of disc.

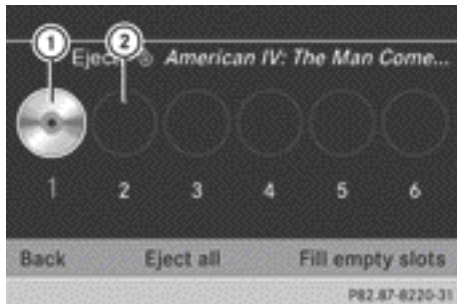

- ① Full magazine tray (eject function is available)
- ② Empty magazine tray (disc can be inserted)

► **To exit the menu:** press the eject/load button again or press the back button.

or

► Select **Back** by sliding and turning the COMAND controller and press to confirm.

► **To fill empty magazine trays:** press the load/eject button. The magazine menu appears.

► Select **Fill empty slots**. You see the **Please wait...** message. COMAND Online switches to the next free magazine tray. You then see the **Please insert disc <x>** message.

i Do not insert a disc into the magazine tray until you have seen this prompt.

► Insert a disc into the disc slot with the printed side facing upwards. You see the **Please wait...** message. Once the disc is loaded, the DVD changer

switches to the next empty tray. You see the **Please insert disc <x>** message.

► Repeat this step until all trays are loaded. The DVD changer plays the last disc you loaded if it has been inserted correctly and it is a permissible type.

► **To cancel loading:** press the eject/load button again or press the back button.

i If you cancel loading with the back button, the system loads and plays the last CD you inserted.

Ejecting discs from the DVD changer

If you remove one disc while playing another disc, the DVD changer interrupts playback. Playback continues once the disc has been ejected.

► **To eject a CD/DVD:** press the load/eject button.

The magazine menu appears. The magazine tray with the current disc is highlighted.

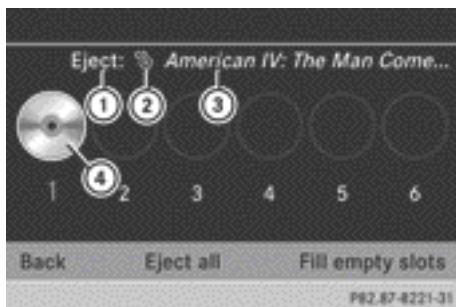

- ① Eject possible
- ② Data medium type
- ③ Disc name (only if stored on the disc)
- ④ Current disc

- ▶ Select a magazine tray containing a disc by turning the COMAND controller and press to confirm.

or

- ▶ Press a number key, e.g. . You see the message: **Ejecting disc <x>...** You then see the following message:



- ▶ Take the disc out of the slot. If you do not take the disc out of the slot, COMAND Online will draw it in automatically after a short while and load it again.

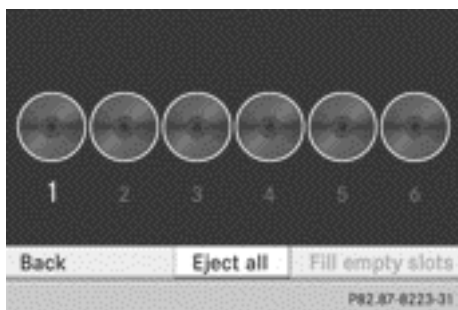

- ▶ **To eject all CDs/DVDs:** press the load/eject button. The magazine menu appears.

- ▶ Select **Eject all** by sliding and turning the COMAND controller and press to confirm.

The DVD changer ejects the last disc selected. You see the **Ejecting disc <x>...** message.

- ▶ Take the disc out of the disc slot when you see the **Please remove disc <x>** message. The DVD changer switches to the next loaded magazine tray and ejects the disc.
- ▶ Repeat the last step until the magazine is empty.
- ▶ **To exit the menu:** press the eject/load button again or press the back button.

or

- ▶ Select **Back** by sliding and turning the COMAND controller and press to confirm.

Inserting and removing an SD memory card

General information

COMAND supports SD memory cards (Secure Digital) and SDHC memory cards (Secure Digital High Capacity).

- i** Not all memory cards available on the market are designed for the temperatures which may be reached in the vehicle.

If the SD memory card is no longer in use, you should remove it from COMAND. High temperatures can damage the card.

Due to the wide range of SD memory cards available on the market, playback cannot be guaranteed for all brands of SD memory card.

The readable storage capacity depends on the memory card used. You can obtain further information at any Mercedes-Benz Service Centre.

Inserting an SD memory card

- ▶ Insert the memory card into the slot on the control panel until it engages in place. The side with the contacts must face downwards and point towards the slot. The first 100 MP3 tracks are loaded. The first MP3 track is then played. Further tracks are loaded in the background; this is indicated by an hourglass symbol. If no MP3 tracks can be found, you will see a message to this effect.

Ejecting an SD memory card

- ▶ Press the memory card. The memory card is ejected.
- ▶ Remove the memory card from the slot.

Connecting a USB device

The USB port is located in the stowage compartment in the centre console.

Electrical consumption at this connection must not exceed a continuous current of 500 mA. If the electrical consumption is higher, use a separate source to provide power for the USB device (e.g. 12 V power supply).

- ▶ Connect the USB device (e.g. USB stick) to the USB port. The first 100 MP3 tracks are loaded. The first MP3 track is then played. Further tracks are loaded in the background; this is indicated by an hourglass symbol. If no MP3 tracks can be found, you will see a message to this effect.

- i** Due to the wide range of USB devices available on the market, playback cannot be guaranteed for all brands of USB device. Information about suitable USB devices can be obtained from a Mercedes-Benz Service Centre. MP3 players must support Media Transfer Protocol (MTP).

Activating the CD/audio DVD or MP3 mode

Inserting or connecting a medium

- ▶ Insert CDs/DVDs (▷ page 460) or
- ▶ Insert an SD memory card (▷ page 463). or
- ▶ Connect a USB device (▷ page 463). COMAND loads the medium inserted and starts to play it.

Switching on with the function button

- ▶ Press the **DISC** function button one or more times.

By pressing the function button repeatedly, you can change the operating mode in the following order:

- CD/audio DVD/video DVD/MP3 CD/MP3 DVD in the DVD changer or single DVD drive (disc mode)
- Memory card mode
- MUSIC REGISTER
- USB memory
- Media Interface or audio AUX mode
- Operation with Bluetooth® audio
- ▶ Select an audio medium from the media list (▷ page 465).

Switching on with the audio menu

- ▶ Select **Audio** in the main function bar by sliding **↑** and turning **⌚** the COMAND controller and press **⌚** to confirm. The last active audio source is now activated. You can activate a different audio source using the audio menu.
- ▶ Select **Audio** by sliding **⌚** and turning **⌚** the COMAND controller and press **⌚** to confirm. The audio menu appears.

- ▶ Select **Disc**, **Memory card**, **Music Register**, **USB storage** or **Media Interface** and press  to confirm.

This switches to the desired audio source.

- ▶ Select an audio medium from the media list (\triangleright page 465).

Example display: CD mode

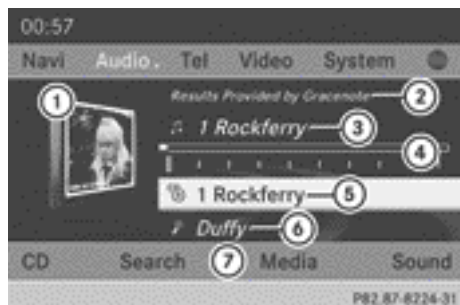

- ① CD cover (if available)
- ② Gracenote data is read, then the elapsed track time
- ③ Track number and track name (if stored on the disc as CD text or if Gracenote® data is available)
- ④ Graphic time and track display
- ⑤ Disc type, disc position in the media list and disc name (if stored on the disc as CD text or if Gracenote® data is available)
- ⑥ Artist (if stored on the disc as CD text or if Gracenote® data is available)
- ⑦ CD mode menu

Example display: audio DVD mode



- ① Cover (if available)
- ② Track time
- ③ Track number
- ④ Graphic time and track display
- ⑤ Disc type, disc position in the media list, disc name (only if stored on the disc)
- ⑥ Audio DVD mode menu

Example display: MP3 mode





- ① Cover (if available)
- ② Track time
- ③ Track number and name
- ④ Graphic time and track display
- ⑤ Medium type, position of medium in the media list, current folder
- ⑥ Artist (if available)
- ⑦ MP3 mode menu

i If no Media Interface is connected during operation with a DVD changer, ⑦ displays **Changer** instead of **Media** (\triangleright page 485).

Pause function

In CD/audio DVD and MP3 mode

- ▶ **To pause playback:** briefly press the  button.





The  symbol appears at the top left in the status bar.



- ▶ **To continue playback:** briefly press the  button again.



The  symbol disappears.

Only in audio DVD mode

- ▶ **To pause playback:** switch on audio DVD mode (▷ page 463).

- ▶ Select  by sliding  and turning  the COMAND controller and press  to confirm.

The  display changes to .







- ▶ **To continue playback:** select  and press  to confirm.



Playback continues from the point where it was interrupted. The  display changes to .

Stop function



This function is only available in audio DVD mode.

- ▶ Switch on audio DVD mode (▷ page 463).



- ▶ **To interrupt playback:** select  by sliding  and turning  the COMAND controller and press  to confirm. The  display changes to . The  symbol remains highlighted.

- ▶ **To continue playback:** select  and press  to confirm.



Playback continues from the point where it was interrupted.

- ▶ **To stop playback:** while playback is interrupted, select  again and press  to confirm.

or

- ▶ Select  and confirm by pressing  twice in rapid succession.

 is highlighted.

- ▶ **To restart playback:** select  and press  to confirm.



Playback starts at the beginning of the DVD.

Selecting CD/audio DVD/MP3 discs

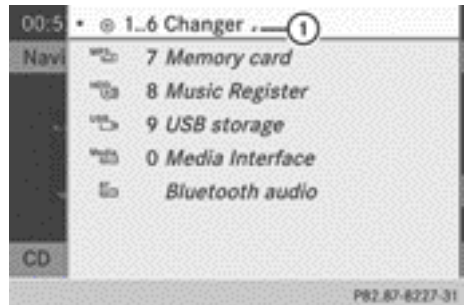
Selecting via the media list





Media list when equipped with a DVD changer



- ▶ **In CD/audio DVD and MP3 mode:** select **Media** or **Changer** by sliding  and turning  the COMAND controller and press  to confirm.

The media list appears. The • dot indicates the current medium being played.

The media list shows the discs currently available.

View in :



-  magazine tray not shown
-  magazine tray shown

- ▶ **To change the display:** select **1...6 changer** by turning  the COMAND controller and press  to confirm. Depending on the previous setting, the magazine trays are shown or not shown.

i If a disc cannot be read, an entry appears next to the corresponding magazine tray.



Media list showing all magazine trays

- ▶ Select the data carrier by turning  the COMAND controller and press  to confirm.

The following tables list the selection options in the media list for the respective equipment variants.

For DVD changer

Magazine trays, positions 1 to 6: readable data media are CDs, MP3 CDs or MP3 DVDs, audio DVDs and video DVDs

Memory card, position 7

MUSIC REGISTER, position 8

USB storage device: position 9

Media Interface: position 0

Bluetooth® audio

Equipped with a single DVD drive

DVD drive, position 1: readable data media are CDs, MP3 CDs or MP3 DVDs, audio DVDs and video DVDs

Memory card, position 2

MUSIC REGISTER, position 3

USB storage device: position 4

Media Interface: position 5

Bluetooth® audio: position 6

- i** If you select a video DVD, the system switches to video DVD mode (▷ page 500).

Selecting a track using the number key-pad



- ▶ When the display/selection window is active, press a number key, e.g. . The medium at the corresponding position in the media list is loaded and then played.

Selecting a track

Selecting by skipping to a track

- ▶ **To skip forwards or back to a track:** turn  the COMAND controller when the display/selection window is active.

or

- ▶ Press the  or  button. The skip forward function skips to the next track.

The skip back function skips to the beginning of the current track if the track has been playing for more than eight seconds. If the track has been playing for less than eight seconds, it skips to the start of the previous track.

If the **Random tracks** or **Random folder** playback option has been selected, the track order is random.

- ▶ Select on the multifunction steering wheel and view in the multifunction display; see the separate vehicle Owner's Manual.

Selecting a track using the number key-pad

- ▶ Press the  key on the number keypad. A numerical entry field appears. The number of positions offered corresponds to the

number of tracks on the CD/DVD. Only numbers that correspond to a track number on the CD/DVD can be entered.

- ▶ Enter the desired track number using the number keys.
The track plays after the last possible number is entered.
- ❶ Pressing and holding a number key for more than two seconds completes the entry, and the corresponding track is played.

Selecting a track using music search



- ▶ Select **Current tracklist**, **Folder** or a category and press \odot to confirm.

Select music via categories (e.g. albums, artists etc.) with the music search function.

If you select a category, COMAND Online starts a search for track information if the following conditions are fulfilled:

- the data carriers are inserted or connected.
- the track information from these data carriers is not yet contained in the COMAND music database.

COMAND imports track information from the following data carriers:

- disc (CD/audio DVD/MP3)
- memory card
- MUSIC REGISTER
- USB storage device

The **Track information is complete** message appears once the search is completed. COMAND Online stores the music data in its own database. You can now select the

available music data within the desired category.

You will find further information on searching for music in the "Music search" section (▶ page 472).

- ▶ In CD/audio DVD/MP3 mode, select **Search** by sliding \odot and turning $\left\langle \odot \right\rangle$ the COMAND controller and press \odot to confirm.
The category list appears.



Example: current track list

- ▶ Select the track by turning $\left\langle \odot \right\rangle$ the COMAND controller and press \odot to confirm.
The basic display appears and the track is played.

Fast forward/rewind

- ▶ While the display/selection window is active, slide $\left\langle \odot \right\rangle$ and hold the COMAND controller until the desired position has been reached.

or

- ▶ Press and hold the \lll or \ggg button until the desired position is reached.

Gracenote Media Database

Introduction

This function is only available in CD mode.

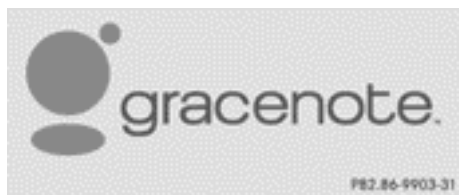

There is a version of Gracenote® music recognition technology on the COMAND Online hard drive. You will recognise this by the logo in the bottom right-hand corner of certain audio displays.

Many CDs contain CD text. COMAND uses the information contained therein to display the artist, album and track name.

If the CD does not contain any CD text information, COMAND can use the Gracenote® Media Database to identify unknown audio tracks when in CD mode. This is only possible if the relevant information is saved in the Gracenote Media Database and if the Gracenote Media Database function is activated.

If this is the case, COMAND will display the corresponding data such as artist, album and track name in the relevant displays and lists.

Selecting Gracenote® data to be displayed

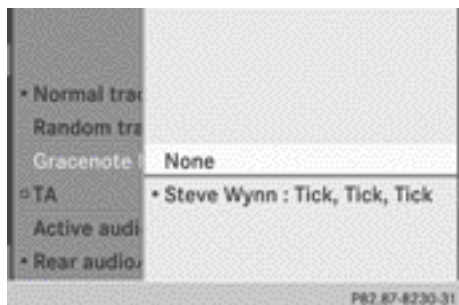

- ▶ Switch on CD mode (▷ page 463).
- ▶ Select **CD** by sliding $\odot \updownarrow$ and turning $\left\{ \odot \right\}$ the COMAND controller and press \odot to confirm.
- ▶ Select **Gracenote Media Database** by turning $\left\{ \odot \right\}$ the COMAND controller and press \odot to confirm.
A menu appears.

The \bullet dot indicates the current selection for the display.

If several entries exist for the CD of a particular artist, you can select which of the entries should be shown.

If the inserted CD does not contain any Gracenote® data, the **Gracenote Media Database** menu item is shown in grey and cannot be selected.

- ▶ Select an entry by turning $\left\{ \odot \right\}$ the COMAND controller and press \odot to confirm.

Switching the Gracenote® data display on/off

- ▶ Switch on CD mode (▷ page 463).
- ▶ Select **CD** by sliding $\odot \updownarrow$ and turning $\left\{ \odot \right\}$ the COMAND controller and press \odot to confirm.
- ▶ Select **Gracenote Media Database** by turning $\left\{ \odot \right\}$ the COMAND controller and press \odot to confirm.
- ▶ **To switch off the display:** select **None** and press \odot to confirm.
In the basic display, **Track 1**, **Track 2** etc. are shown instead of the Gracenote® data, for example (▷ page 464).
- ▶ **To switch on the display:** select an entry in the menu by turning $\left\{ \odot \right\}$ the COMAND controller and press \odot to confirm.

Updating Gracenote® music recognition technology and the Gracenote Media Database

Due to the release of new CDs, the digital data on the Gracenote Media Database must be updated. Optimum functionality can only be attained with up-to-date Gracenote® music recognition technology. Information about new versions can be obtained from a Mercedes-Benz Service Centre.

You can have your music recognition software updated there with a DVD, or you can update it yourself.

i The Gracenote Media Database is updated in conjunction with the navigation system's digital map (▷ page 374).

Displaying the track and album

▶ Press the  button.



The current track and album are displayed in a window.

Displaying metadata (MP3 mode)

COMAND can also display the album name and artist (metadata) during playback if this information has been entered into the system.

For all media that contain MP3 data (e.g. MP3 CD, SD memory card, MUSIC REGISTER), you can determine whether:

- the metadata contained in the tags of the encoded music data should be displayed
- the file and directory names should be displayed during playback

▶ **To display the album and artist name:** select **MP3** or **USB** in the basic display by sliding  and turning  the COMAND controller and press  to confirm.

▶ Select **Display track information** and press  to confirm.

Selecting a group (audio DVD)



The content of an audio DVD can be divided into up to nine groups. The availability and type of group depends on the respective DVD.



A group can contain music in different sound qualities (stereo and multichannel formats, for example), or bonus tracks.

Each group can contain up to 99 tracks.



If an audio DVD only contains one audio format, the **Group** menu item(s) cannot be selected.



▶ Switch on audio DVD mode (▷ page 463).

▶ Select **DVD-A** by sliding  and turning  the COMAND controller and press  to confirm.

▶ Select **Group** by turning  and press  to confirm.



The • dot indicates the group currently selected.

▶ Select the desired group by turning  and press  to confirm.

▶ **To exit the menu:** slide   the COMAND controller or press the  button.

Selecting an active partition (USB mass storage devices only)



You can select this function for USB mass storage devices when the storage device is partitioned. Up to nine partitions (primary or logical; FAT and FAT32) are supported.

▶ Select **MP3** in the basic display by sliding  and turning  the COMAND controller and press  to confirm.



▶ Select **Select active partition** and press  to confirm.

Playback options

▶ **To select options:** switch on CD/audio DVD or MP3 mode (▷ page 463).

▶ Select **CD, DVD-A** or **MP3** by sliding  and turning  the COMAND controller and press  to confirm.

The options list appears. The • dot indicates the option selected.

▶ Select an option by turning  and press  to confirm.

The option is switched on. For all options except **Normal track sequence**, you will see a corresponding display in the display/selection window.

The following options are available to you:

• Normal track sequence

The tracks are played in the normal order (e.g. track 1, 2, 3 etc.).

In MP3 mode, the track order is determined by the order in which the tracks are written to the MP3 data carrier when it is created. Alphabetical order is the most common.

Once all the tracks in a folder have been played, the tracks in the next folder are played.

- **Random media**

All the tracks on the medium are played in random order (e.g. track 3, 8, 5 etc.).

- **Random track list** (MP3 mode only)

You will hear the tracks in the current playlist or currently active folder (including all subfolders) in random order.

- **i** The **Normal track sequence** option is automatically selected when you change the disc you are currently listening to or when you select a different medium. If an option is selected, it remains selected after COMAND is switched on or off.

Notes on MP3 mode

General notes

Depending on the volume and format of the MP3 data, the length of time required for reading the data may increase.

Permissible data carriers

- CD-R and CD-RW
- DVD-R and DVD-RW
- DVD+R and DVD+RW
- SD memory card
- USB storage device

Permissible file systems

- ISO 9660/Joliet standard for CDs
- UDF for audio and video DVDs
- FAT16 or FAT32 for SD memory cards and USB storage media

Multisession CDs

For multisession CDs, the content of the first session determines how COMAND will process the CD. COMAND plays only one session and gives priority to the CD session.

If possible, use COMAND to play only CDs that have been written in one session.

File structure of a data carrier

When you create a disc with compressed music files, the tracks can be organised in folders. A folder may also contain subfolders. The disc may contain no more than eight directory levels. Files beyond the eighth level will not be recognised by the system.

- **i** COMAND Online loads up to 15,000 tracks from an SD memory card or USB storage medium.

Track and file names

When you create a disc with compressed music files, you can assign names to the tracks and folders.

COMAND uses these names accordingly for the display. Folders that contain data other than MP3 or WMA tracks are not displayed by COMAND.

If MP3 or WMA files are stored in the root directory itself, the root directory will also be treated as a folder. COMAND will then show the name of the root directory as the folder name.

You should observe the following when assigning track names:

- track names must have at least one character.
- track names must have the extension "mp3" or "wma".
- there must be a full stop between the track name and the extension.

Example of a correct track name:
"Track 1.mp3".

Permissible formats

COMAND supports the following formats:

- MPEG1 Audio Layer 3 (MP3)
- Microsoft Windows Media Audio V8 and V9 (WMA) without copy protection
Microsoft Windows Media Audio V2, V7, V8 and V9 (WMA)
- additional music files in AAC format with the file extensions .aac, .mp4, .m4a

and .m4b, but not copy-protected iTunes music files with the extension .m4p

- i** If, in addition to MP3 files, there are other music files in these audio formats stored on the disc, the loading process may require a longer time before the first track is played.
- i** The MP3 audio encoding method is under licence from Fraunhofer IIS (Institut Integrierte Schaltungen – Institute for Integrated Circuits) and Thomson.

Permissible bit and sampling rates

COMAND supports **MP3** files of the following types:

- fixed and variable bit rates from 32 kbit/s to 320 kbit/s
- sampling rates of 8 kHz to 48 kHz

COMAND supports **WMA** files of the following types:

- fixed bit rates from 5 kbit/s to 384 kbit/s
- sampling rates of 8 kHz to 48 kHz

COMAND does **not** support **WMA** files of the following types:

- DRM (Digital Rights Management) encrypted files
- variable bit rate
- WMA Pro
- 5.1 Surround

- i** Only use tracks with a bit rate of at least 128 kbit/s and a sampling rate of at least 44.1 kHz. Lower rates can cause a noticeable deterioration in quality. This is especially the case if you have activated a surround sound function.

Notes on copyright

MP3 or WMA tracks that you create or play back are generally subject to copyright protection in accordance with the applicable international and national regulations.

In many countries, reproductions, even for private use, are not permitted without the prior consent of the copyright holder.

Make sure that you know about the applicable copyright regulations and that you comply with these.

If you own these rights yourself, e.g. for your own compositions and recordings, or if the copyright holder has granted you permission, these restrictions do not apply.

Notes on CDs/DVDs

i COMAND Online is designed to play discs which comply with the EN 60908 standard. Therefore, you can only use discs with a maximum thickness of 1.3 mm.

If you insert thicker discs, e.g. those that contain data on both sides (DVD on one side and audio data on the other), they cannot be ejected and can damage the device.

Only use round discs with a diameter of 12 cm. Do not use discs with a diameter of 8 cm, even with an adapter.

Discs with copy protection are not compatible with the CD standard and therefore may not be able to be played by COMAND Online.

You may encounter playback problems when playing copied discs. There is a wide range of data carriers, disc-writing software and writers available. This variety means that there is no guarantee that the system will be able to play discs that you have copied yourself.

There may be playback problems if you play CDs that you have copied yourself with a storage capacity of more than 700 MB. CDs of this type do not conform to the currently applicable standards.

- i** On many DVD audio discs, the last track does not contain any music. If COMAND therefore switches to the next disc, it is normal system behaviour and does not mean that there is a malfunction.
- i** COMAND is able to play back CDs in multichannel audio format.

Music search

Calling up the category list



Category list

- ▶ Switch on an audio source and call up the basic display, e.g. MP3 mode (▷ page 463).
- ▶ Select **Search** by sliding $\odot \updownarrow$ and turning $\left\{ \odot \right\}$ the COMAND controller and press \odot to confirm. The category list appears.

The categories are displayed according to the data available. The categories **Current tracklist**, **Folder**, **Playlists** (if available) and **Photos** (if available) are already assigned. The other available categories are filled by the music search.

Selecting a category

Starting a music search

Select music via categories (e.g. albums, artists etc.) with the music search function.

If you select a category, COMAND Online starts a music search under the following conditions:

- the data carriers are inserted or connected.
- the music tracks on these data carriers are not yet in the COMAND music database.

COMAND Online reads music tracks from the following data carriers:

- disc (audio CD/DVD/MP3)
- memory card

- MUSIC REGISTER
- USB storage device



- ▶ Select a category in the category list by turning $\left\{ \odot \right\}$ the COMAND controller and press \odot to confirm. The **Reading data...** message appears. The search may take some time, depending on the number of tracks available.

The **Track information is complete** message appears once the search is completed. Playback then starts with the previously active audio source.

- ▶ **To cancel the music search:** confirm **Cancel** by pressing \odot .

Selecting artists

- ▶ Select **Artists** in the category list by turning $\left\{ \odot \right\}$ the COMAND controller and press \odot to confirm. The available artists are displayed alphabetically.

Selecting an album



- ▶ Select **Albums** in the category list by turning **⏪** the COMAND controller and press **⏩** to confirm.

The available albums are displayed alphabetically. If there is a cover available for an album, it is displayed in front of the album name.

Selecting a track



- ▶ Select **Tracks** in the category list (▷ page 472) by turning **⏪** the COMAND controller and press **⏩** to confirm. The available tracks are displayed.

Selecting a year of publication



- ▶ Select **Year** in the category list (▷ page 472) by turning **⏪** the COMAND controller and press **⏩** to confirm.
- ▶ Select an entry and press **⏩** to confirm. The genre list is displayed.

- ▶ Select a genre, e.g. pop, and press **⏩** to confirm. The track list is displayed.
- ▶ Select a track and press **⏩** to confirm. Playback starts.

Selecting composers

- ▶ Select **Composers** in the category list by turning **⏪** the COMAND controller and press **⏩** to confirm. The available composers are displayed alphabetically.

Selecting music genres

- ▶ Select **Genres** in the category list by turning **⏪** the COMAND controller and press **⏩** to confirm. The available music genres are displayed alphabetically.

Selecting a cover

- ▶ Select **Select by cover** in the category list (▷ page 472) by turning **⏪** the COMAND controller and press **⏩** to confirm. The available covers are displayed in alphabetical order of the artists.

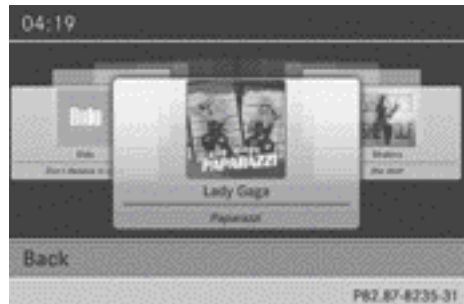

- ▶ Select the desired cover by turning **⏪** the COMAND controller and press **⏩** to confirm. The corresponding album is played.

Selecting via keyword search

- ▶ Select **Keyword search** in the category list by turning the COMAND controller and press to confirm. An input menu appears.



- ▶ **To change the character set used in the character bar:** highlight **Select** by sliding and turning the COMAND controller and press to confirm. A list of available character sets is shown.

- ▶ Select the desired character set and press to confirm.
- ▶ Enter characters and confirm the entry. Character entry ([▷ page 298](#)). Depending on the entry, the hits are shown in a list.

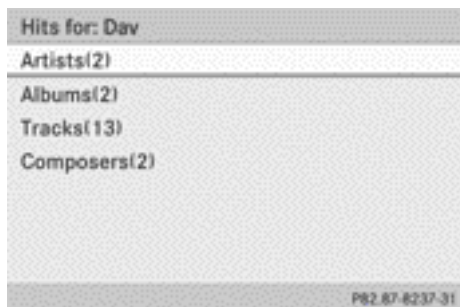

- ▶ Select an entry by turning the COMAND controller and press to confirm.



- ▶ Select an entry, e.g. **Artists**, and press to confirm. The album and cover (if available) are displayed.



- ▶ Confirm the album with . The tracks on the album are displayed.



- ▶ Select a track and press to confirm. Playback starts and the basic display appears.

MUSIC REGISTER

General notes

I Retain the original music files in a secure location. An error in COMAND Online might result in the loss of the music files stored in the MUSIC REGISTER. Mercedes-Benz is not liable for any loss of data.

You can store music files in a compressed format in the MUSIC REGISTER (▷ page 476). The memory has a capacity of 10 GB.

Switching to the MUSIC REGISTER

MUSIC REGISTER basic display

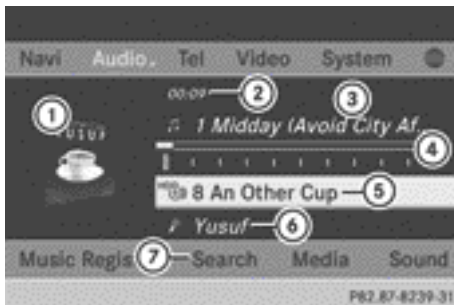

Example: MUSIC REGISTER

- ① Cover (if available)
- ② Track time
- ③ Track number and name
- ④ Graphic time and track display
- ⑤ Position of the medium in the media list and name of the medium, followed by the current playback option (no display for **Normal track sequence**)
- ⑥ Artist
- ⑦ MUSIC REGISTER menu bar

Switching on with the function button

▶ Press the **DISC** function button repeatedly until the MUSIC REGISTER is switched on.

By pressing the function button repeatedly, you can change the operating mode in the following order:

- Audio CD/DVD/MP3 (disc)
- Memory card mode
- MUSIC REGISTER
- USB memory
- Media Interface or audio AUX mode
- Operation with Bluetooth® audio

If music files are available, playback begins at the point last listened to.

If there are no music files, you will see a message to this effect.

▶ Confirm the message by pressing **OK** and copy the data to the MUSIC REGISTER (▷ page 476).

Switching on with the audio menu

▶ Select **Audio** in the main function bar by sliding **↑** and turning **⌂** the COMAND controller and press **OK** to confirm.

If the MUSIC REGISTER was the last mode selected, it is now switched on.

If another audio source is switched on, you can now switch on the MUSIC REGISTER in the audio menu.

▶ Select **Audio** by sliding **↑** and turning **⌂** the COMAND controller and press **OK** to confirm.

The audio menu appears.

▶ Select **Music Register** and press **OK** to confirm.

Switching on with the number buttons

▶ Press the **8** (for a DVD changer) or **3** (for a single DVD drive) number key. The MUSIC REGISTER is switched on.

Copying music data to the MUSIC REGISTER

Introduction

You can copy music files in the file formats MP3, WMA and AAC (with the file extensions .m4p, .m4a, .m4b and .aac) from the following media:

- discs in a DVD changer or a single DVD drive
- Memory card
- USB memory

i While copying, several functions will not be available. If this is the case, you will see a message to this effect.

1. Selecting a data medium

- ▶ Switch to the MUSIC REGISTER (▷ page 475).
- ▶ Select **Music Register** by sliding $\odot \updownarrow$ and turning $\left\{ \odot \right\}$ the COMAND controller and press \odot to confirm.
- ▶ Select **Copy MP3 music files** and press \odot to confirm.

The media list appears. A data carrier from which files can be copied is selected automatically.

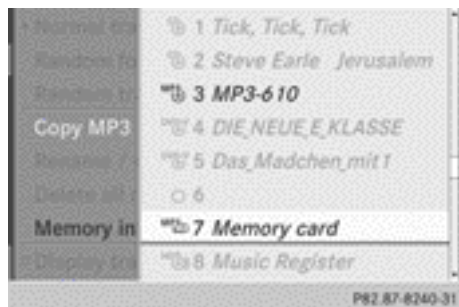

- ▶ Select the data medium by turning $\left\{ \odot \right\}$ the COMAND controller and press \odot to confirm.
The data medium is loaded.
If the data carrier contains music files that can be copied, you see a menu.



2. Selecting music files

- ▶ **To select all music files:** select **All tracks** and press \odot the COMAND controller to confirm.

This function copies all music files on the selected data carrier. The icon in front of **All tracks** is filled in and all following entries have a tick beside them.

- ▶ **To select a folder:** turn $\left\{ \odot \right\}$ the COMAND controller and press \odot to confirm.
A tick next to the folder entry highlights the selection.

3. Confirming your selection

- ▶ Select **Continue** by turning $\left\{ \odot \right\}$ the COMAND controller and press \odot to confirm.
The copying menu appears.

4. Starting the copying process

- !** Under no circumstances should you remove the medium while you are copying data from it (SD memory card, USB storage device, CD/DVD). Doing so will generate unusable data in the MUSIC REGISTER.

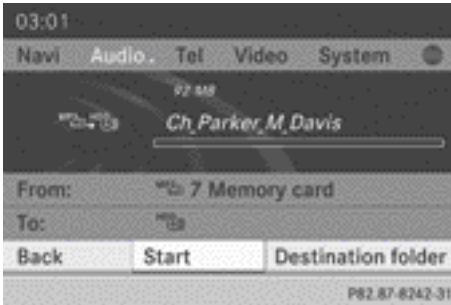

In the example, music files are copied from the memory card to the MUSIC REGISTER.

- ▶ **To select a target folder:** select **Destination folder** by turning **⏮** the COMAND controller and press **⏹** to confirm.
- ▶ Select **Folder** and press **⏹** to confirm. The folder is selected .
- ▶ Select **Continue** and press **⏹** to confirm.
- ▶ Confirm **Start** by pressing **⏹**. Copying begins. The progress bar indicates the status of the copying procedure.

i It may take some time for the copying process to be completed, depending on the amount of data. If there is not enough memory space, you will see a message to this effect.

Once copying is complete, you hear the first track on the album copied. The MUSIC REGISTER display appears. Now you can copy more music files to the MUSIC REGISTER.

- ▶ **To cancel the copying process:** select **Cancel** and press **⏹** to confirm. Music files are stored in the MUSIC REGISTER up until the point of cancellation.

Deleting all music files

! In order to prevent malfunctions, do not use COMAND Online during this time.

This function deletes all music files from the MUSIC REGISTER.

- ▶ Switch to the MUSIC REGISTER (▷ page 475).
- ▶ Select **Music Register** by sliding **⏴** and turning **⏮** the COMAND controller and press **⏹** to confirm.
- ▶ Select **Delete all music files** and press **⏹** to confirm. A query appears. **No** is highlighted. If you select **Yes**, all music files are deleted. You see the **Please wait...** message. Then, you see the **Data deleted.** message. If you select **No**, the process will be aborted.

Calling up memory space information

- ▶ Switch to the MUSIC REGISTER (▷ page 475).
- ▶ Select **Music Register** by sliding **⏴** and turning **⏮** the COMAND controller and press **⏹** to confirm.
- ▶ Select **Memory info** and press **⏹** to confirm. The following is displayed:
 - storage capacity
 - available memory
 - occupied memory
 - content (folders, tracks)

Music search

Introduction

The music search finds tracks via all available media. The search begins with the audio source that is currently active.

The music search covers the following media:

- disc (audio CD/DVD/MP3)
- Memory card
- MUSIC REGISTER
- USB memory

- ▶ Switch to the MUSIC REGISTER (▷ page 475).
- ▶ Select **Search** by sliding $\odot \downarrow$ and turning $\{\odot\}$ the COMAND controller and press \odot to confirm. The category list appears.
- ▶ Select a track in a category (▷ page 472).

Example: opening a folder

- ▶ Select **Folder** in the category list by turning $\{\odot\}$ the COMAND controller and press \odot to confirm. You see the contents of the current folder.



The name of the current folder is at the top and the track currently playing is indicated by a • dot.

- ▶ **To switch to the next folder up:** press the \leftarrow back button or slide $\leftarrow \odot$ the COMAND controller.

Changing the folder/track name

- ▶ Switch to the MUSIC REGISTER (▷ page 475).
- ▶ Select **Music Register** by sliding $\odot \downarrow$ and turning $\{\odot\}$ the COMAND controller and press \odot to confirm.
- ▶ Select **Rename / delete files** and press \odot to confirm.
- ▶ Select a folder/track by turning $\{\odot\}$.
- ▶ Select **Options** by sliding $\odot \rightarrow$ and press \odot to confirm.
- ▶ Select **Edit** and press \odot to confirm.

- ▶ Enter a name for the folder/track (▷ page 298).
- ▶ **To save the changes:** select $\boxed{\text{ok}}$ and press \odot to confirm.

Deleting folders/tracks

- ▶ Switch to the MUSIC REGISTER (▷ page 475).
- ▶ Select **Music Register** by sliding $\odot \downarrow$ and turning $\{\odot\}$ the COMAND controller and press \odot to confirm.
- ▶ Select **Rename / delete files** and press \odot to confirm.
- ▶ Select a folder/track by turning $\{\odot\}$.
- ▶ Select **Options** by sliding $\odot \rightarrow$ and press \odot to confirm.
- ▶ Select **Delete** and press \odot to confirm.

A query appears. **No** is highlighted.





If you select **Yes**, the folders/tracks are deleted. You see the **Please wait...** message. Then, you see the **Data deleted** message.

If you select **No**, the process will be cancelled.

Playback options

The following options are available:

- **Normal track sequence**
The tracks are played in the normal order (e.g. track 1, 2, 3, etc.).
- **Random media**
All the tracks on the medium are played in random order.
- **Random track list** (MP3 mode only)
The tracks in the currently active folder or the current track list are played in a random order.

- ▶ **To select options:** switch to the MUSIC REGISTER (▷ page 475).
 - ▶ Select **Music Register** by sliding  and turning  the COMAND controller and press  to confirm. The options list appears. The • dot indicates the option selected.
 - ▶ Select an option and press  to confirm. The option is switched on. For all options except **Normal track sequence**, you will see a corresponding display in the display/selection window.
- i** The **Normal track sequence** option is automatically selected when you change the disc you are currently listening to or when you select a different medium. If an option is selected, it remains selected after COMAND Online is switched on or off.

Operation with Bluetooth® audio

Preconditions for the Bluetooth® audio device

Bluetooth® audio mode requires a Bluetooth®-capable audio device. Observe the information in the Bluetooth® audio device's operating instructions.

Before using Bluetooth® audio mode, you should check your Bluetooth® audio device for the following:

- Bluetooth® audio profile

The Bluetooth® audio device must support the A2DP and AVRCP Bluetooth® audio profiles.
- Bluetooth® visibility

Certain Bluetooth® audio devices do not just require activation of the Bluetooth® function. In addition, your device must be made "visible" to other devices.
- Bluetooth® device name

This device name is predetermined but can usually be changed. To make a clear selection of the Bluetooth® device possible,

Mercedes-Benz recommends that you customise the device name.

- i** **A2DP (Advanced Audio Distribution Profile):** Bluetooth® audio profile for audio data transmission
- AVRCP (Audio Video Remote Control Profile):** Bluetooth® audio profile for audio data playback
- i** Not all Bluetooth® audio devices available on the market are equally suitable. Information on suitable Bluetooth® audio devices and on connecting Bluetooth® audio devices to COMAND Online:
 - is available from your Mercedes-Benz Service Centre
 - or visit the website <http://www.mercedes-benz.com/connect>.
- ▶ Activate Bluetooth® and Bluetooth® visibility on the Bluetooth® audio device.

Preconditions in COMAND Online

- ▶ Activate the Bluetooth® function in COMAND Online(▷ page 306).

Connecting Bluetooth® audio devices

General information

Before using your Bluetooth® audio device with COMAND Online for the first time, you will need to authorise it.

When you authorise a new Bluetooth® audio device, it is connected automatically. Connection involves first searching for a Bluetooth® audio device and then authorising it. You can authorise up to fifteen Bluetooth® devices.

- i** If you authorise a mobile phone that supports Bluetooth® audio, the A2DP and AVRCP Bluetooth® audio profiles are connected automatically.

The mobile phone is then entered:

- in the Bluetooth® telephone list (▷ page 383)
- in the Bluetooth® device list (▷ page 480).

Mercedes-Benz recommends authorising a mobile phone in Bluetooth® telephony (▷ page 383).

Searching for and authorising a Bluetooth® audio device



Example: Bluetooth® device list

- ① Newly detected mobile phone with Bluetooth® audio function in range
- ② Bluetooth® audio player not within range but previously authorised (symbol appears in grey)

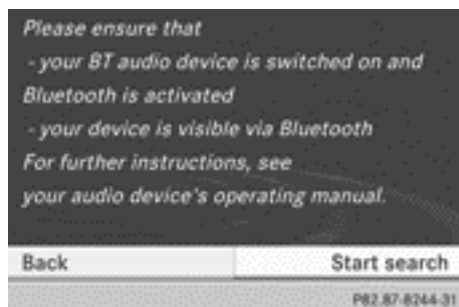

The Bluetooth® device list displays all authorised devices, whether they are within range or not. After a device search, devices which are within range but not authorised are also displayed.

- ▶ Switch on Bluetooth® audio mode (▷ page 483).
If you see the **No Bluetooth audio device authorised** message, you will need to authorise the Bluetooth® audio device first.
- ▶ Select **BT audio** by sliding and turning the COMAND controller and press to confirm.

- ▶ Confirm **Bluetooth audio device list** by pressing the COMAND controller.

- ▶ **To search:** confirm **Search for BT audio devices** by pressing the COMAND controller.

COMAND Online searches for Bluetooth® audio devices within range and adds them to the Bluetooth® device list. Bluetooth® audio devices are detected if they support the Bluetooth® audio profiles (A2DP, AVRCP).

The duration of the search depends on the number of Bluetooth® audio devices within range and their characteristics.

- ▶ **To authorise:** a Bluetooth® audio device that has not yet been authorised from the list (① in the example) by turning the COMAND controller.
- ▶ Select the symbol to the right of the Bluetooth® audio device by sliding the COMAND controller and press to confirm.
- ▶ Select **Authorise** and press to confirm. Depending on the Bluetooth® audio device used, you now have two options for continuing with authorisation.
- ▶ **Option 1:** enter the passkey (▷ page 383). After successful authorisation, the Bluetooth® audio device is connected and starts playing.
- ▶ **Option 2 (Secure Simple Pairing):** if the digit codes displayed in COMAND Online

and on the Bluetooth® audio device are the same, confirm **Yes** by pressing .

If you select **Yes**, authorisation continues and the Bluetooth® audio device is connected. Playback starts.





If you select **No**, authorisation will be cancelled.

- i** The Bluetooth® audio device must support Bluetooth® version 2.1 for connection via Secure Simple Pairing. COMAND Online creates a six-digit code, which is displayed on both devices that are to be connected.

External authorisation



If COMAND Online does not find your Bluetooth® audio device, this may be due to particular security settings on your Bluetooth® audio device. In this case, check whether your Bluetooth® audio device can locate COMAND Online. The Bluetooth® device name of COMAND Online is **MB Bluetooth**.

- ▶ Switch on Bluetooth® audio mode (▷ page 483).
- ▶ Select **BT audio** by sliding  and turning  the COMAND controller and press  to confirm.
- ▶ Confirm **Bluetooth audio device list** by pressing  the COMAND controller.

- ▶ **To search:** confirm **Connect via BT audio device** by pressing  the COMAND controller.

The duration of the search depends on the number of Bluetooth® audio devices within range and their characteristics.

- ▶ **To authorise:** start the authorisation on the Bluetooth® audio device, see the operating instructions of the Bluetooth® audio device.

After successful authorisation, the Bluetooth® audio device is connected and starts playing.

- i** With some Bluetooth® audio devices, playback must be initially started on the device itself, so that COMAND Online can play the audio files.

Reconnecting a Bluetooth® audio device

The Bluetooth® audio profiles are connected automatically under the following circumstances:

- one of the last two mobile phones to have been connected has also been used as a Bluetooth® audio player (if this function is supported by the mobile phone).
- the mobile phone takes over the automatic connection itself.

A Bluetooth® audio player without telephone functions is not automatically reconnected, even if it was the last device connected.

If the **No Bluetooth audio device connected** message appears, you have two options to connect a Bluetooth® audio device:

Connecting last device

- ▶ Confirm **Connect last device** in the basic display by pressing  the COMAND controller.

If COMAND Online can locate the Bluetooth® audio device, it will be connected and start playing.

- i** With some Bluetooth® audio devices, playback must be initially started on the

device itself, so that COMAND Online can play the audio files.

Connecting a device from a list

- ▶ Select **BT audio** by turning the COMAND controller and press to confirm.
- ▶ Confirm **Bluetooth audio device list** by pressing the COMAND controller.
- ▶ Select a Bluetooth® audio device by turning the COMAND controller and press to confirm.

If COMAND Online can locate the Bluetooth® audio device, it will be connected and start playing.

- i** With some Bluetooth® audio devices, playback must first be started on the device itself, so that COMAND Online can play the audio data.

Bluetooth® audio device and simultaneous search for mobile phones

During the search for mobile phones, the connection with the Bluetooth® audio device is terminated (▷ page 382). In the Bluetooth® audio basic display, you will see the **No Bluetooth audio device connected** message and the **Connect last device** menu item cannot be selected.

Displaying details

- ▶ Select a Bluetooth® audio device in the Bluetooth® device list.
- ▶ Select the symbol to the right of the Bluetooth® audio device by sliding the COMAND controller and press to confirm.
- ▶ Select **Details** and press to confirm. The following information concerning the selected mobile phone is shown:
 - Bluetooth® name
 - Bluetooth® address

- availability status (shown after an update)
- authorisation status

- ▶ **To close the detailed view:** turn or slide the COMAND controller.

De-authorising (de-registering) a Bluetooth® audio device

- ▶ Select a Bluetooth® audio device in the Bluetooth® device list.
- ▶ Select the symbol to the right of the Bluetooth® audio device by sliding the COMAND controller and press to confirm.
- ▶ Select **De-authorise** and press to confirm. A prompt appears asking whether you really wish to de-authorise this device.
- ▶ Select **Yes** or **No**.

If you select **Yes**, the device will be deleted from the Bluetooth® device list.

If you select **No**, the process will be cancelled.

- i** Before re-authorising the Bluetooth® audio device, you should also delete the device name **MB Bluetooth** from your Bluetooth® audio device's Bluetooth® list. See the Bluetooth® audio device's operating instructions.

Switching to Bluetooth® audio mode

The Bluetooth® audio basic display

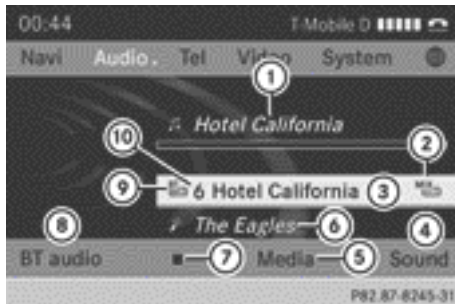

Example: Bluetooth® audio basic display

- ① Track name
 - ② Current playback settings (no symbol for "Normal track sequence")
 - ③ Album name
 - ④ Sound settings
 - ⑤ Media list
 - ⑥ Artist
 - ⑦ To stop or start playback
 - ⑧ To connect a Bluetooth® audio device, to switch traffic announcements on/off, to increase the volume on COMAND Online
 - ⑨ Bluetooth® audio data medium type
 - ⑩ Data carrier position in the media list
- i** If the Bluetooth® audio device connected supports metadata and corresponding data is available, then the artist, track and album name can be displayed.

Using the Bluetooth® audio basic display

- ▶ Connect (▷ page 479) the Bluetooth® audio device.

or

- ▶ Reconnect the Bluetooth® audio device (▷ page 481).
COMAND Online activates the Bluetooth® audio device. The basic display appears and the device starts playing.

Using the function button

- ▶ Press the function button one or more times.

By pressing the function button repeatedly, you can change the operating mode in the following order:

- CD/ audio DVD/MP3 (disc)
- memory card mode
- MUSIC REGISTER
- USB memory
- Media Interface or audio AUX mode
- Bluetooth® audio mode

Using the media list

- ▶ Select **Bluetooth audio** in the media list by turning the COMAND controller and press to confirm (▷ page 465).
COMAND Online activates the connected device. You will see a message to this effect. The basic display then appears.

Starting/stopping playback

- ▶ **To start playback:** select by sliding and turning the COMAND controller and press to confirm.
Playback starts. is selected.
- ▶ **To stop playback:** select by turning the COMAND controller and press to confirm.
A message appears. is selected.
- ▶ **To continue playback:** select by turning the COMAND controller and press to confirm.
A message appears. is selected.

Restarting playback after stopping



During the search for mobile phones, the connection with the Bluetooth® audio device is terminated (▷ page 382). In the Bluetooth® audio basic display (▷ page 483), you will see the **No Bluetooth audio device connected** message and the **Connect last device** menu item cannot be selected.



When the search is finished, the Bluetooth® audio device can be reconnected.

- ▶ Confirm **Connect last device** by pressing .

Depending on the Bluetooth® audio device used, playback starts immediately or you must start playback manually.



In this case, you will see the **Bluetooth audio device paused** message.









- ▶ **To start playback:** select  by turning  the COMAND controller and press  to confirm. Playback resumes from the beginning.

Selecting a track

The function is not supported by all Bluetooth® audio devices.

- ▶ **To skip forwards or backwards to a track:** press the  or  button on COMAND Online.

or

- ▶ Press the  or  button briefly on the multifunction steering wheel.
- ▶ **Rapid scroll:** press and hold the  or  button on the multifunction steering wheel until the desired track is reached. If you press and hold the  or  button, the rapid scrolling speed is increased.

Selecting playback options

If the Bluetooth® audio device supports the corresponding function, the following options are available:



- **Normal track sequence**

The tracks are played in the normal order (e.g. track 1, 2, 3, etc.).



Audio data playback is determined by the order in which the tracks are written to the data carrier. Alphabetical order is the most common. Once all the tracks in a folder have been played, the tracks in the next folder are played.

- **Random tracks**

All the tracks on the medium are played in random order (e.g. track 3, 8, 5 etc.).

- ▶ Select **BT audio** by sliding  and turning  the COMAND controller and press  to confirm.

The • dot indicates the option selected.

- ▶ Select the option by turning  the COMAND controller and press  to confirm.

If you select **Random tracks**, you will see a corresponding symbol in the display/selection window.

Increasing the volume on COMAND Online

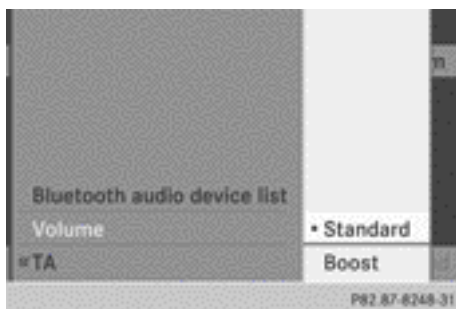

- ▶ Select **BT audio** by sliding $\odot \updownarrow$ and turning $\left[\odot \right]$ the COMAND controller and press \odot to confirm.
- ▶ Select **Volume** and press \odot to confirm. A menu appears. The \bullet dot indicates the current setting.
- ▶ Select **Standard** or **Boost** and press \odot to confirm.

Information about sound settings
(▷ page 294).

Information about Traffic Programme
(▷ page 458)

You will find further information in the "Audio AUX mode" section (▷ page 491).

Media Interface mode

Connection options

Overview

The connection sockets are located in the stowage compartment in the centre console. Device-specific adapter cables are required to connect external devices to the Media Interface. Country-specific versions are supplied with the Media Interface (▷ page 485). You can connect the following data carriers to COMAND Online via the Media Interface:

- iPod®
- iPhone®
- certain MP3 players

- i** Store individual parts in a safe place. Only use genuine Mercedes-Benz connection cables.
- i** iPod® and iPhone® are registered trademarks of Apple Inc., Cupertino, California, USA.
- i** MP3 players that support MTP (Media Transfer Protocol) can be used. This allows the MP3 player to be easily connected to the Media Interface and removed after use. Audio data is played without problem. On some MP3 players, you have to activate the relevant function; see the MP3 player operating instructions.

Supported devices

For further details and a list of supported devices, contact a Mercedes-Benz Service Centre or visit the website at <http://www.mercedes-benz-mobile.com/connect>. Then, follow the instructions in the "Media Interface" section.

Connecting an external device

Do not leave external devices in the vehicle. At extreme temperatures, they cannot be guaranteed to function correctly; see the operating instructions of the device in question. Examples of extreme temperatures are direct sunlight or very low outside temperatures. Mercedes-Benz accepts no liability for damage to external devices.

- i** Never connect more than one device at a time. You will otherwise not be able to play back from the external device. USB hubs (devices with several USB connections) are not supported.

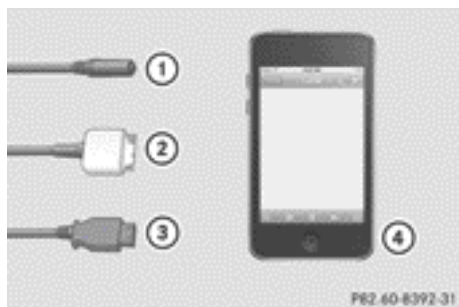

- ① 4-pin socket for 3.5 mm stereo jack, e.g. for MP3 players (audio and video)
- ② iPod® plug, to connect an iPod®
- ③ USB socket, to connect an MP3 player
- ④ Example of device (iPod®)

► Connect the external device with suitable socket ①, ② or ③.
COMAND Online activates the device, a message appears (when connecting an iPod® plug or USB socket).

If you remove a device, the **No device connected** message appears.

i A connected iPod® or MP3 player should not be simultaneously operated via the Media Interface and the remote control (e.g. Bluetooth® remote control) or directly via the device itself. Doing so may cause unforeseen technical difficulties.

Applications (apps) that are activated on the connected device may lead to malfunctions.

i Connecting a fully discharged iPod® or MP3 player can result in an extended initialisation period.

Error messages appear while the device is being activated if:

- the connected device is not supported (**External device unavailable** message).
- the connected device consumes too much power.

- the Media Interface connection is faulty.
- a mass storage device (e.g. USB memory stick or USB hard drive) is connected to the Media Interface.

In this case the message **Please connect the device to the other USB port** appears.

i The separate USB connection ensures quick access and expanded media content options.

i Information is available at any Mercedes-Benz Service Centre.

Switching to Media Interface mode

General notes

In extreme cases, starting up individual functions can take up to several minutes; this depends on the external device and its content (e.g. video podcasts).

Only use the original software to save files on iPods® or MP3 players. Otherwise, some or all functions may not be available.

Switching on automatically

► Connect an external device (▷ page 485). COMAND Online activates the device (when connecting an iPod® plug or USB socket). The basic display then appears.

Switching on with the function button

The external device is connected to the Media Interface.

► Press the **DISC** function button one or more times.

By pressing the function button repeatedly, you can change the operating mode in the following order:

- audio CD/DVD/MP3 (disc)
- memory card mode
- MUSIC REGISTER
- USB memory
- Media Interface or audio AUX mode
- operation with Bluetooth® audio

Switching on using a number key

- ▶ Press the **0** number key (for a DVD changer) or the **5** number key (for a single DVD drive) number key. This selects the connected external audio device directly.

Switching on via the media list

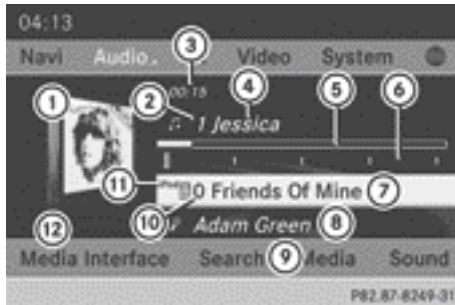

Media Interface mode (iPod® mode) when equipped with a DVD changer

- ① Cover (if available) or representation of device
 - ② Track number
 - ③ Elapsed track time (also in format 00:00:00 for audio books)
 - ④ Track name
 - ⑤ Graphic time display
 - ⑥ Track position in playlist
 - ⑦ Album name (if available)
 - ⑧ Artist (if available)
 - ⑨ Music search
 - ⑩ Position in the media list
 - ⑪ Data medium type
 - ⑫ Playback options
- ▶ Select the entry under position 0 (DVD changer) or position 5 (single DVD drive) in the media list by turning **⏪** the COMAND controller and press **⏩** to confirm (▷ page 465). COMAND Online activates the connected device. You will see a message to this effect. The basic display then appears.

If no device is connected, you will see the **Media Interface** entry instead of a device name.

The type of device connected is indicated by the corresponding symbol for iPod® (iPhone®) or MP3 player.

The current playback option is shown with a symbol behind album name (no display for **Normal track sequence**) (▷ page 490).

- ❗ If the device connected does not contain any playable tracks, a message appears to this effect.

Selecting music files

Note

COMAND Online displays the data stored on the iPod®, iPhone® or MP3 player according to the file structure used in the respective medium.

Selecting by skipping to a track

- ▶ **To skip forwards or back to a track:** turn **⏪** the COMAND controller when the display/selection window is active.



or

- ▶ Press the **⏪** or **⏩** button.

The skip forward function skips to the next track. The skip back function skips to the beginning of the current track if the track has been playing for more than eight seconds. If the track has been playing for less than eight seconds, it skips to the start of the previous track. If you have selected a playback option other than **Normal track sequence**, the track sequence is random.

- ▶ **On the multifunction steering wheel:** switch to Media Interface mode in COMAND Online (▷ page 486).
- ▶ On the multifunction steering wheel, press the ◀ or ▶ button to select the [Audio](#) menu.
- ▶ Press the ▲ or ▼ button briefly. If you hold down the ▲ or ▼ button, the system scrolls through the list more quickly. Not all media players support this function.
If track information is available on the media player, the multifunction display shows the number and name of the track.

Selecting using the number keypad

- ▶ **To make an entry:** press the  button. An input menu appears. The number of characters available for input depends on the number of stored tracks.
- ▶ **To enter a track number:** press a number key, e.g. .
The digit is entered in the first position in the input line.
- i** COMAND Online will ignore and not display an invalid digit.
- ▶ Enter more numbers if desired.
The track plays after the last possible number is entered.
- i** Pressing and holding a number key for more than two seconds completes the entry, and the corresponding track is played.

Fast forward/rewind

- ▶ While the display/selection window is active, slide ◀⊙▶ and hold the COMAND controller until the desired position has been reached.
- or
- ▶ Press and hold the ▶▶ or ◀◀ button until the desired position is reached.
 - i** On an iPod® or iPhone®, fast rewind only functions within the current track.

Selecting a category/playlist/folder

Overview

For an iPod®, iPhone® or certain MP3 players, you can select tracks using categories or folders.

Depending on the device connected, the following categories may be available, for example:

- [Current tracklist](#)
- [Select by cover](#)
- [Keyword search](#)
- [Playlists](#) (e.g. [All](#))
- [Artists](#)
- [Albums](#)
- [Tracks](#)
- [Podcasts](#)
- [Genres](#)
- [Composers](#)
- [Audiobooks](#)
- [Videos](#)

i Some playback categories contain the entry [All](#). If this entry has been selected, the entire content of the category selected will be played.

The [Videos](#) category is available for iPods® and iPhones®.

i The functions are available as soon as the entire media content has been read and analysed. For certain functions, such as keyword search and selection by cover, this can take several minutes, depending on the scope of media and the connected device.

If the same device is reconnected with unchanged media content, these functions are available much more quickly.

However, if you change the media content, it has to be read and analysed again.

Calling up the category list

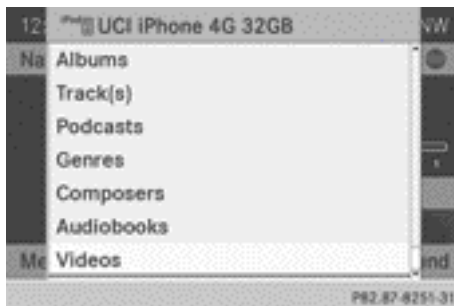

Example: category list

- ▶ Select **Search** in the basic display by sliding $\odot \downarrow$ and turning $\{\odot\}$ the COMAND controller and press \odot to confirm. The category list appears.

i **Search** is not available until the device has been activated.

i **Reading:** if the media content of the connected device is being read, this is indicated on the upper right by a symbol. When reading has ended, the categories **Select by cover** and **Keyword search** are available.

Depending on the connected device and the size of the media content, reading may take several minutes. When the device is next started or reconnected, the advanced functions will be quickly available.

However, if you change the media content on your iPod®/iPhone®, it has to be read and analysed again.



Example: current track list

- ① Symbol for next folder up
- ② Device symbol and device name
- ③ Track symbol
- ④ Current track

- ▶ Select **Current tracklist** by turning $\{\odot\}$ the COMAND controller and press \odot to confirm.

The content of the current track list appears.

- ▶ Select the track by turning $\{\odot\}$ the COMAND controller and press \odot to confirm.

The track is played.

- ▶ **To switch to the next folder up:** slide $\leftarrow \odot$ the COMAND controller.

or

- ▶ Press the $\boxed{\leftarrow}$ back button.

Playing back the contents of a category or folder

- ▶ Select the category or folder by turning $\{\odot\}$ the COMAND controller.

- ▶ Press \odot the COMAND controller for longer than two seconds.



The content of the category or folder selected is played in accordance with the playback option selected (▷ page 490).

Alphabetical track selection

iPod®, iPhone® and MP3 player

This function is available for alphabetically sorted categories and folders. This function

is not available for albums or playlists, for example.

- ▶ Select a category, e.g. **Artists**, by turning  the COMAND controller and press  to confirm.

The available artists are displayed.

- ▶ Press the corresponding number key once or repeatedly to select the initial letter of the desired artist. For example, to select an artist whose name begins with C, press the

 number key three times.

The available letters are listed at the lower edge of the display.

After a message, the first entry in the list that matches the letter entered is highlighted.

- i** If no corresponding entry exists, the last entry corresponding to a previous letter is highlighted instead.

- i** iPods and MP3 players: the quality of the search results is highly dependent on the version and language variant of the software used to populate the device. A well-known example of such software is iTunes®.

If different sorting rules are defined (e.g. in iTunes®), the search is cancelled without any result.

Additional selection functions

- **Select by cover**

Albums can be chosen by cover using the menu item.

The first time the **Select by cover** function is used, additional data must be loaded from the iPod®/iPhone®. The current music playback is interrupted to allow access to this data. The process may take a few minutes and should not be cancelled. Otherwise, it will start again from the beginning the next time **Select by cover** is selected. Covers are initially searched for in the Gracenote Media Database and are then added to during playback from the connected device (▷ page 467). The avail-

ability depends on the use and the tracks already selected.





- **Keyword search**

Selecting keyword search allows you to search through all categories on the connected device for keywords.

- i** For more information on **Select by cover** and **Keyword search** can be found under "Music search, selecting category" (▷ page 488).

- i** For an iPod®/iPhone®, the available covers are added most efficiently if the entire media content is in the current playlist. This is the case if you have selected the playback option **Tracks** or **Random media** (▷ page 490).

Playback options

- ▶ **To select a playback option:** select **Media Interface** in the basic display by sliding  and turning  the COMAND controller and press  to confirm. The options list appears. The • dot indicates the option selected.
- ▶ Select an option and press  to confirm.

The following options are available:

- **Normal track sequence**

Normal track sequence: you hear the tracks in their normal order (e.g. numerical or alphabetical).

- **Random media**

All the tracks on the medium are played in random order.

- **Random track list**

The tracks in the currently active category or folder, including any subfolders, are played in random order.

MP3 player instructions

General information

Up to 30,000 tracks per medium are supported.

You can speed up some functions and improve the search results by:

- making sure the names of tracks, albums and artists, for example, are written the same way
- labelling albums featuring various artists as "compilations"

i Multiple entries of tracks in playlists are filtered out for some players.

Data formats

MP3 and WMA are supported as data formats with fixed and variable bit rates (up to 320 kbit/s).

Special considerations when using MP3 players

Up to eight directory levels with up to 1,000 tracks per directory are supported.

Do not use USB extension leads or adapters. They can impair functionality.

i DRM (Digital Rights Management) protected files are not supported by the Media Interface.

Audio AUX mode

Notes on audio AUX mode

WARNING

External audio sources may have different volumes, which can mean that system messages such as traffic announcements and navigation system announcements are much louder. If necessary, please deactivate the system messages or adjust their volume manually.

You can connect an external audio source (AUX) to COMAND Online. You will find the socket in the centre console stowage compartment.

If COMAND Online is equipped with a Media Interface, external audio sources are connected using the cable set provided. The cable set then replaces the audio AUX socket. The connections for the Media Interface are located in the stowage compartment in the centre console.

i You can find more information on the Internet at <http://www.mercedes-benz.com/connect> and in the "Media Interface mode" section (▷ page 485).

Switching to audio AUX mode

Switching on with the function button

The external device is connected to the audio AUX source.



▶ Press the **DISC** function button one or more times.

By pressing the function button repeatedly, you can change the operating mode in the following order:

- Audio CD/DVD/MP3 (disc)
- Memory card mode
- MUSIC REGISTER
- USB memory
- Media Interface or audio AUX mode
- Operation with Bluetooth® audio



Switching on with the audio menu

When you connect an external audio source, audio AUX is not selected automatically.

▶ Select **Audio** in the main function bar by sliding  and turning  the COMAND controller and press  to confirm.

If AUX mode was the last mode selected, it will now be active.

If another audio source is switched on, you can now switch to audio AUX mode in the audio menu.

▶ Select **Audio** using  and press  to confirm.

The audio menu appears.

- ▶ Select **Aux** using and press to confirm.

The audio AUX menu appears. The medium in the external audio source is played if the source is connected and playback selected.



Please see the respective operating instructions for how to operate the external audio source.

Information on:

- volume settings (▶ page 294)
- sound settings (▶ page 294)

Increasing the volume on COMAND Online

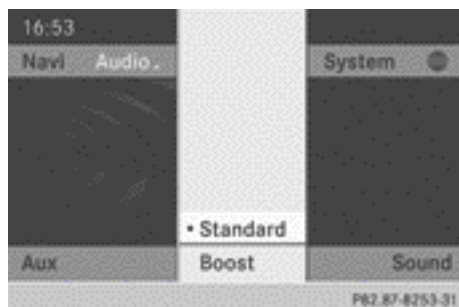

- ▶ Select **Volume** in the AUX display by turning the COMAND controller and press to confirm.

A menu appears. The • dot indicates the current setting.

- ▶ Select **Standard** or **Boost** and press to confirm.

Standard: the volume of the external audio source is adjusted to a standard value.

Boost: the volume of the external audio source is raised by approximately 10 dB.

A device which is connected as an external audio source may seem quieter or louder in the vehicle, or the usual maximum volume cannot be achieved. On some devices, it is possible to adjust the volume separately. In this case, start at a medium volume and increase it gradually. This enables you to determine whether the system is able to play the music at high volume without distorting it.

Video

Features of your COMAND Online

This Supplement describes all the standard and optional equipment for your COMAND Online system, as available at the time of going to print. Country-specific differences are possible. Please note that your COMAND Online system may not be equipped with all the features described.

General notes

Automatic picture shutoff

If the vehicle is travelling faster than approximately 5 km/h, the picture automatically switches off in the following modes:

- TV mode (with teletext)
- Video DVD mode

The following message appears in the display: **In order not to distract you from the traffic situation, the picture is faded out while the vehicle is in motion.**

As soon as the vehicle speed drops below about 5 km/h, the picture switches back on again.

Background video mode

If another main function is active, e.g. navigation, you can perform the following operations in TV and video DVD mode. A window shows information about the selected function.

Using the  or  button, you can:

- select a TV channel
- select a scene or chapter (video DVD mode)
- fast forward or rewind (video DVD mode)





Where operating steps can be carried out in the active main function using the number keys, the following functions are **not** possible:

- selecting TV channels from the channel presets
- storing TV channels in the channel presets

Basic settings

Adjusting the brightness, contrast or colour

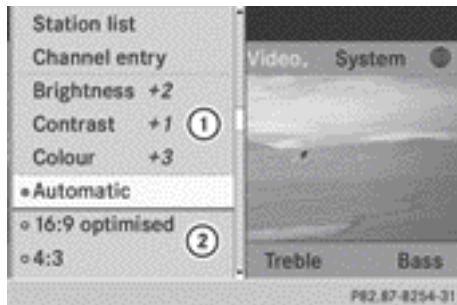

The following describes the TV, video DVD and video AUX modes.

- ▶ Press  the COMAND controller in TV or video DVD mode and show the menu.
- ▶ Select **TV**, **DVD-V** or **Aux** by sliding  and turning  the COMAND controller and press  to confirm. A menu appears.









Example display: TV mode

- ① Brightness, contrast and colour
- ② Picture formats

- ▶ Select **Brightness**, **Contrast** or **Colour** by turning  the COMAND controller and press  to confirm.

Changing the picture format

The following describes the TV, video DVD and video AUX modes.

- ▶ Press  the COMAND controller in TV or video DVD mode and show the menu.
- ▶ Select **TV**, **DVD-V** or **Aux** by sliding  and turning  the COMAND controller and press  to confirm. A menu appears.
- ▶ Select **Automatic**, **16:9 optimised**, **4:3** or **Widescreen** and press  to confirm. The dot in front of the entry indicates the currently selected format.
- ▶ Select a setting by turning  the COMAND controller and press  to confirm.

TV mode

Reception quality

Portable electronic devices in the vehicle may seriously impair TV reception.

The TV tuner is designed to receive digital TV channels compliant with the DVB-T standard. If the reception deteriorates, the TV receiver

automatically switches to an alternative digital frequency transmitting the same programme content with better reception.

- i** In some countries, DVB-T may not be available, or may not be available in all areas.

The constantly changing reception conditions while the vehicle is in motion can interrupt the signal. If the reception is too poor, COMAND Online can switch off the sound and freeze or hide the picture. To indicate this, an icon of a radio tower with a line through it appears in the display.

Switching to TV mode



Video menu

- ▶ Select **Video** in the main function bar by sliding ←○→ or turning ⏪⏩ the COMAND controller and press ⏹ to confirm. If TV mode was the last mode selected, it will now be active. If another mode is switched on, you can now switch on TV mode in the video menu.
- ▶ Select **Video** and press ⏹ to confirm. The video menu appears.
- ▶ Select **TV** and press ⏹ to confirm. If the TV channel that was previously selected is still receivable, it will be displayed.

Showing/hiding the navigation menu

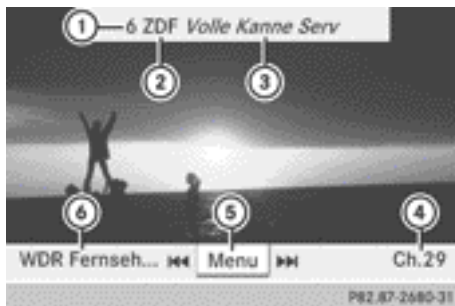

Navigation menu displayed

- ① Preset position of the selected TV channel
- ② Selected TV channel
- ③ Current programme
- ④ Next TV channel in the channel list (channel name or number)
- ⑤ To show the menu
- ⑥ Previous TV channel in the channel list (channel name or number)

▶ **To show:** turn ↑○↓ or slide ⏪⏩ the COMAND controller.

- i** If you turn the COMAND Controller, the next/previous station is selected.

▶ **To hide:** slide ↑○↓ the COMAND controller.

or

▶ Wait for approximately eight seconds.

Showing/hiding the menu



Menu shown

- ① TV options
- ② Channel preset list
- ③ Information about the current programme
- ④ To switch on teletext
- ⑤ Sound settings

► **To show:** press the COMAND controller.

or

► Select **Menu** while the control menu is shown and press to confirm.

► **To hide:** slide the COMAND controller and confirm **Full screen** by pressing .

i Information about current programme ③ and teletext ④ are not supported by all TV standards or TV channels in all countries.

Selecting TV channels

Selecting channels using the navigation menu

► Turn the COMAND controller.

or

► Slide the COMAND controller.

or

► Press the or button.

The TV tuner selects the previous or next channel from the alphabetical channel list.

Selecting a channel from the channel list

After starting the vehicle or switching on COMAND Online, all receivable TV and radio stations are listed by the reception function. The respective channel list contains the following information, if it is transmitted and can be received:

- the names of the channels that can be received
- the name of the current and next programme on each channel

The background reception function requires a certain amount of time to update this information. COMAND Online can only display the information if the TV channels are transmitting it and if the reception conditions are adequate. The electronic programme guide (EPG) provides the titles of the current and upcoming programmes.

The order of the channel list is country-specific.

► To set a channel using

COMAND Online: press the COMAND controller.

The menu is shown.

► Select **TV** by sliding or turning the COMAND controller and press to confirm.

► Select **TV channel list** or **Radio station list** and press to confirm.

The station list appears. The dot in front of a list entry indicates the currently selected channel. A number before the list entry shows the memory slot in the channel presets.

► Select the channel and press to confirm.

► **To set a channel using the multifunction steering wheel:** switch on TV mode in COMAND Online (▷ page 494).

► Press the or button to select the **Audio** menu.

► Press and hold the or button.

Selecting stations via the station presets



Station presets

Selecting a station in COMAND Online:

- ▶ **Option 1:** press the COMAND controller. The menu is shown.
- ▶ Select **Preset** by sliding or turning the COMAND controller and press to confirm. The station preset memory appears. The ● dot in front of a preset position indicates that the currently selected station is stored there.
- ▶ Select and confirm a station by turning or sliding the COMAND controller press to confirm.

or

- ▶ **Option 2:** briefly press one or two number keys. To select a station from a single-digit preset, briefly press the number key. To select a station from a double-digit memory position, briefly press the and number keys, for example. If a station was saved, the storage number and station name appear and COMAND Online sets the station. To save a TV channel automatically or manually (▷ page 497).

- ▶ **To set a channel using the multifunction steering wheel:** switch on TV mode in COMAND Online (▷ page 494).

▶ Press the or button to select the **Audio** menu.

▶ Press the or button briefly.

Selecting channels by entering the channel and programme number

Several programmes can be transmitted on one channel with digital TV. You can therefore enter a channel and the desired programme on this channel.

- ▶ **Step 1: Call up the input line for the channel number:** press during TV playback.

or

- ▶ Press the COMAND controller. The menu is shown.
- ▶ Select **TV** by sliding or turning the COMAND controller and press to confirm.
- ▶ Select **Channel entry** and press to confirm. The input line for the four-digit channel number appears.

- ▶ **Step 2: To enter a channel/programme number:** press the corresponding number keys.

As soon as you have entered the channel/programme number, COMAND Online sets the channel/station.

If you only enter the first two or three digits of the channel/programme number, the first receivable programme will be set within the programme series.

If you have not entered a programme number, the first programme with adequate reception will be set.

If you enter channels that are either not intended for or not allowed in your country, the **Invalid channel number** message appears.

- ▶ Press  the COMAND controller and confirm the message.

i You can enter channel numbers or programmes available in your country even if the reception is currently not adequate. Information on channel numbers available in your country can be found on the website of the private or public broadcaster.



Storing TV channels

Storing stations manually

You can manually store up to twenty TV channels in preset positions. Along with the "Store channels automatically" function, a total of forty presets are available.

- ▶ **Option 1:** press one or two number keys while a TV programme is playing, until a tone can be heard.

To save a station from a single-digit memory position, briefly press the  number key, for example.





To save a station from a double-digit memory position, briefly press the  number key, for example. Then within three seconds, press and hold , for example.

The current station is stored under the corresponding preset. The TV picture then reappears.



or

- ▶ **Option 2:** press  the COMAND controller.

The menu is shown.

- ▶ Select **Preset** by sliding   or turning  the COMAND controller and press  to confirm.







The channel preset memory appears. The **•** dot in front of a preset position indicates that the channel currently selected is stored there.

- ▶ Turn  the COMAND controller to select the desired preset position.
- ▶ To store a channel, press and hold  the COMAND controller until you hear a tone. The previously saved channel is overwritten.









Storing stations automatically

You can automatically store up to twenty TV channels in preset positions. Receivable channels are stored in order of reception quality. The current preset stations in positions 1 – 20 are manually overwritten.

Along with the "Store channels manually" function, a total of forty presets are available.

- ▶ **To show the menu:** press  the COMAND controller.
- ▶ Select **Preset** by sliding   or turning  the COMAND controller and press  to confirm.
- ▶ Select **Autostore** and press  to confirm. COMAND Online searches for channels with adequate reception. The available channels are automatically stored in the preset positions.

Information about the current programme

- ▶ **To show the menu:** press  the COMAND controller.
- ▶ Select **Info** by sliding   or turning  the COMAND controller and press  to confirm. You will see the information if it is provided by the selected TV channel or radio station. The information field otherwise remains empty.
- ▶ To display multi-page information, turn  or slide   the COMAND controller.

i It may take a few seconds for the information to appear.

Displaying the current programme or programme preview

This function is available if the selected TV or radio station transmits the necessary information.

- ▶ **To show the menu:** press the COMAND controller.
- ▶ Select **TV** by sliding or turning the COMAND controller and press to confirm.
- ▶ Select **TV channel list** or **Radio station list**.

The selected station list appears. It shows the current programme on the digital TV channels or digital radio stations which have adequate reception. The • dot in front of a list entry indicates the currently selected station.

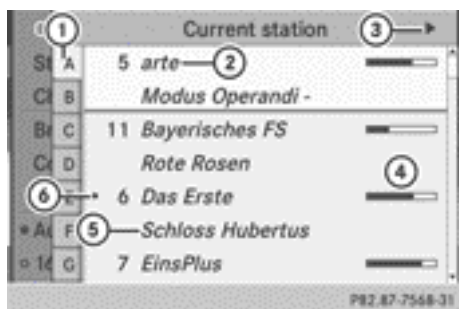

- ① Alphabetical browser
- ② Station name
- ③ To display the programme preview
- ④ Visual display of the elapsed programme time (if this information is broadcast)
- ⑤ Title of the current channel
- ⑥ Current channel

- ▶ **To activate the alphabetical browser:** slide the COMAND controller to the left.

- ▶ Select the initial letter of the desired channel name by sliding or the COMAND controller.

or

- ▶ To select the letter **B**, for example, press the number key twice in quick succession.

The programme display changes to the appropriate channel.

- ① Entering characters using the number keypad (▶ page 300).

- ▶ Switch back by sliding .

- ▶ **To display the programme preview:** slide the COMAND controller to the right. The channel list shows the channel's next programme.

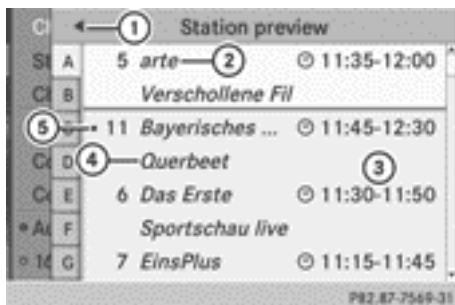

- ① To display the current programme
- ② Station name
- ③ The beginning and end of the programme
- ④ Title of the next channel
- ⑤ Current channel

- ▶ **To display the current programme:** slide the COMAND controller to the links.

- ▶ **To close the display:** press the back button.









The alphabetical browser cannot be activated in the programme preview.

- i** The programme preview is also referred to as the electronic programme guide (EPG).

Basic TV settings









Fixing the frequency

Depending on reception levels, country or TV standard, the TV tuner automatically switches to an alternative channel with better reception if it is broadcasting the same programme content. You can use the **Channel fix** function to prevent this channel switching. This is useful, e.g. if there is a disruptive time delay between the channels or if there is interference on a channel.

- ▶ **To show the menu:** press  the COMAND controller.
- ▶ Select **TV** by sliding   or turning  the COMAND controller and press  to confirm.
- ▶ Select **Channel fix** and confirm with .
- ▶ The function is switched on or off , depending on the previous status. When the function is switched on, **FIX** appears in the display window.
- ▶ **To exit the menu:** slide   the COMAND controller or press the  back button.
- i** The setting is only valid for the currently selected channel.

Setting the reception region

COMAND Online is set to the correct reception region at the factory. If you are driving your vehicle in a different country or region, you should set COMAND Online accordingly. In an incorrect reception area, channels may not be found or characters may be incorrectly displayed. A Mercedes-Benz Service Centre can help you to select the correct reception region.







- ▶ **To show the menu:** press  the COMAND controller.
- ▶ Select **TV** by sliding   or turning  the COMAND controller and press  to confirm.
- ▶ Select **TV standard** and press  to confirm.
A list appears, showing the reception regions. The **•** dot in front of a list entry indicates the currently selected reception area or country.
- ▶ Select the reception area and press  to confirm.
A message appears to inform you that if the wrong country is set, correct reception will not be possible.
- ▶ Select **Yes** or **No** and press  to confirm.
If you select **Yes**, COMAND Online will switch to the country setting you have selected.
If you select **No**, the country list will appear again.

Teletext

Introduction

Teletext and data service functions are not supported by all TV standards in all countries. Teletext can only be received if there is no interference in the picture reception. The teletext or data service functions receive and save all teletext pages for the currently selected channel in the system memory. This excludes any subpages. If you set a different channel, the memory is cleared and refilled.

Switching teletext on/off

- ▶ **To show the menu:** press  the COMAND controller.
- ▶ **To switch on:** select **Teletext** by sliding   and turning  the COMAND controller and press  to confirm.
- ▶ **To switch off:** press and hold the  back button.
The TV picture appears.

Selecting a teletext page

- ▶ **To access a page directly:** press the corresponding number keys.
- ▶ **To access the previous/next page:** turn **⏪** or slide **⬆** the COMAND controller.
- ❗ You can only enter pages that are permissible for teletext between 100 and 899.

Dynamic teletext page

A dynamic teletext page consists of several subpages.

- ▶ **To select the underside:** slide **⬅** the COMAND controller.

Select Audio.

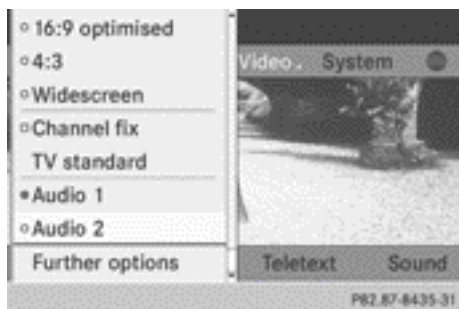

If a multilingual broadcast is received, you can select the audio channel you would like to hear. With **Audio 1** you can select the main channel, with **Audio 2** you can choose an additional audio track.

- ▶ **To show the menu:** press **⏻** the COMAND controller.
- ▶ **To switch on:** select **TV** by sliding **⬅** or turning **⏪** the COMAND controller and press **⏻** to confirm.
- ▶ Select **Audio 1** or **Audio 2** by sliding **⬆** the COMAND controller.

The • dot in front of an entry indicates the selected setting.

The audio channel switches over e.g. to another language.

Further options

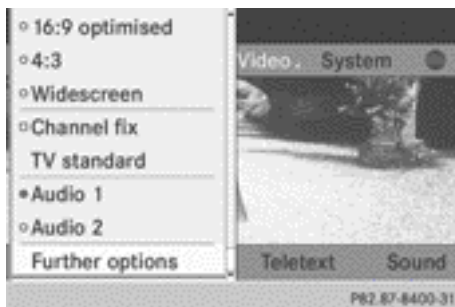

- ▶ **To show the menu:** press **⏻** the COMAND controller.
- ▶ **To switch on:** select **TV** by sliding **⬅** or turning **⏪** the COMAND controller and press **⏻** to confirm.
- ▶ Select **Further options** by turning **⬆** or sliding **⏪** the COMAND controller and press **⏻** to confirm. A menu appears.
- ▶ Confirm **Language & subtitles** with **⏻** the COMAND controller. If available, you can select the audio language and the language of the subtitles for the current programme e.g. English.

Video DVD mode

Important safety notes

⚠ WARNING

COMAND Online is classified as a Class 1 laser product. Never open the housing. There is a risk of damage to the eyes due to exposure to invisible laser radiation if you open the casing, or if the casing is faulty or damaged. COMAND Online does not contain any parts that can be serviced by the user. For safety reasons, all maintenance work must be carried out by qualified aftersales technicians.

⚠ WARNING

Only when the vehicle is stationary should you:

- load a disc
- eject a disc

There is a risk of being distracted from the road and traffic conditions if this is done while the vehicle is in motion.

Notes on discs

! Do not affix stickers or labels to the discs. They could peel off and damage COMAND Online. Stickers can cause the disc to bend, which can result in read errors and disc recognition problems.

! COMAND Online is designed to play discs which comply with the EN 60908 standard. Therefore, you can only use discs with a maximum thickness of 1.3 mm.

If you insert thicker discs, e.g. those that contain data on both sides (DVD on one side and audio data on the other), they cannot be ejected and can damage the device. Only use round discs with a diameter of 12 cm. Do not use discs with a diameter of 8 cm, even with an adapter.

You may encounter playback problems when playing copied discs. There are a large variety of discs, DVD authoring software, writing software and writers available. This variety means that there is no guarantee that the system will be able to play discs that you have copied yourself.

DVD playback conditions

There are video DVDs available on the market that do not conform to the current standards. Such DVDs may have picture, sound or other playback problems.

COMAND Online is capable of playing back video DVDs produced according to the following standards:

- Region code 2 (for Europe) or region code 0 (no region code)
- PAL or NTSC standard

You will generally find the relevant details either on the DVD itself or on the DVD case.

i If you insert a video DVD with a different region code, you will see a message to this effect.

i COMAND Online is set to region code 2 at the factory. This setting can be changed at a Mercedes-Benz Service Centre. This will allow you to play video DVDs with a different region code, provided that they are produced in accordance with the PAL or NTSC standard. The region code can be changed a maximum of five times.

Function restrictions

Depending on the DVD, it is possible that certain functions or actions will be temporarily blocked or may not function at all. As soon as you try to activate these functions or actions, you will see the  symbol in the display.

Inserting and removing DVDs

- ▶ Proceed as described in the "Inserting and ejecting CDs and DVDs" section (▷ page 460).

Switching to video DVD mode**Switching on automatically**

- ▶ **Single DVD drive:** insert a video DVD. COMAND Online loads the medium inserted and starts to play it.

▶ **DVD changer:** insert a video DVD.

▶ Press .

or

▶ Press the  back button.







COMAND Online loads the medium inserted and starts to play it.

Switching on with the function button



▶ Press the  function button one or more times.

COMAND Online switches to the previous disc operating mode.

By pressing the function button repeatedly, you can change the operating mode in the following order:



- audio CD/DVD/video DVD/MP3 in the DVD changer or single DVD drive (disc mode)
- audio CD/DVD/video DVD/MP3 in the DVD changer (disc mode)
- Memory card mode
- MUSIC REGISTER
- USB memory
- Media Interface or audio AUX mode
- Operation with Bluetooth® audio
- ▶ **DVD changer:** select **Media** or **Changer** by sliding  and turning  the COMAND controller and press  to confirm.
- ▶ **Single DVD drive:** select **Media** by sliding  and turning  the COMAND controller and press  to confirm.
- ▶ Select a  video DVD from the media list (> page 504).

Switching on with the video menu

▶ Select **Video** in the main function bar by sliding  and turning  the COMAND controller and press  to confirm.

If video DVD mode was the last mode selected, it will now be active.

If another video source is switched on, you can now switch to video DVD mode in the video menu.

▶ Select **Video** by sliding  the COMAND controller and press  to confirm.

The video menu appears.

▶ Select **DVD-V** and press  to confirm.

Showing/hiding the navigation menu

▶ **To show:** in DVD video mode, slide  the COMAND controller.

▶ **To hide:** slide  the COMAND controller.

or

▶ Wait for approximately eight seconds.

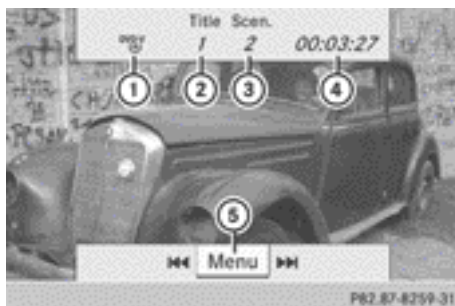

Navigation menu displayed

- ① Data medium type
- ② Current track
- ③ Current scene
- ④ Track time
- ⑤ To show the menu



i This function is not available while the DVD's own menu is being displayed.

Showing/hiding the menu

▶ **To show:** in full-screen DVD video mode, press  the COMAND controller.

or

▶ Select **Menu** while the navigation menu is shown and press  to confirm.

▶ **To hide:** slide  the COMAND controller and confirm **Full screen** by pressing .

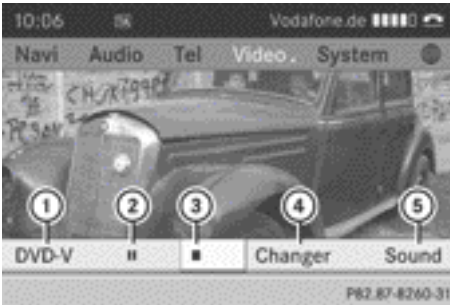

Menu shown

- ① Video DVD options
 - ② Pause function
 - ③ Stop function
 - ④ Media selection (Changer or Media)
 - ⑤ Sound settings
- i** This function is not available while the DVD's own menu is being displayed.

Fast forward/rewind

- ▶ In full-screen DVD video mode, slide $\leftarrow \odot \rightarrow$ and hold the COMAND controller until the desired position is reached.

or

- ▶ Press and hold the \lll or \ggg button until the desired position is reached. You see the navigation menu.

Stop function

- ▶ Show the menu (▷ page 502).
- ▶ **To interrupt playback:** select \blacksquare by turning $\{\odot\}$ the COMAND controller and press \odot to confirm. The \parallel display changes to \blacktriangleright . The video image is hidden.
- ▶ **To continue playback:** select \blacktriangleright and press \odot to confirm. Playback continues from the point where it was interrupted.

- ▶ **To stop playback:** while playback is interrupted, select \blacksquare again and press \odot to confirm.

or

- ▶ During playback, confirm \blacksquare by pressing \odot twice in rapid succession.

\blacktriangleright is selected.

- ▶ **To restart playback:** confirm \blacktriangleright by pressing \odot . Playback restarts from the beginning.

Pause function

- ▶ Show the menu (▷ page 502).

- ▶ **To pause playback:** select \parallel by turning $\{\odot\}$ the COMAND controller and press \odot to confirm.

The \parallel display changes to \blacktriangleright .

- ▶ **To continue playback:** select \blacktriangleright and press \odot to confirm. The menu is hidden.

Selecting a scene/chapter

If the film is divided into scenes or chapters, you can select them directly while the film is running, or skip forwards step by step. Some DVDs do not permit this at certain points (e.g. during the opening credits).

It may also be possible to select the scene/chapter from within the menu stored on the DVD.

- ▶ **To skip forwards or back:** in full screen mode, turn $\{\odot\}$ the COMAND controller.

or

- ▶ Slide $\leftarrow \odot \rightarrow$ the COMAND controller

or

- ▶ Press the \lll or \ggg button on the control panel.

The navigation menu (▷ page 502) appears for approximately eight seconds.

- ▶ **On the multifunction steering wheel:** switch to video DVD mode in COMAND Online (▷ page 501).
- ▶ Use the ◀ or ▶ button to select the **Audio** menu.
- ▶ Press the ▲ or ▼ button to select a scene/chapter.
If you press and hold the ▲ or ▼ button for an extended period, rapid scroll begins.

Selecting a film/title

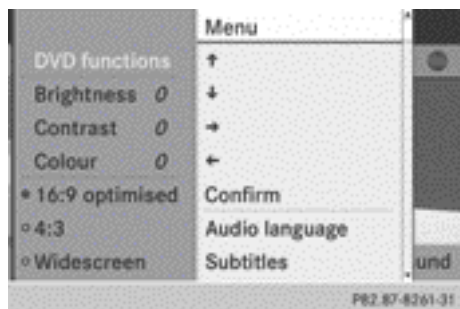

DVD function menu

This function is only available if the DVD is divided into several films/titles. If the DVD contains several films, these can be selected directly. A film can be selected either when the DVD is being played back or when it is stopped.

The film can also be selected from the menu on the DVD itself.

- ▶ Show the menu (▷ page 502).
- ▶ Select **DVD-Video** by turning ⏪ the COMAND controller and press ⏩ to confirm.
- ▶ Select **DVD functions** and press ⏩ to confirm.
A menu appears.
- ▶ Select **Title selection** by turning ⏪ the COMAND controller and press ⏩ to confirm.
- ▶ Select a film/title and press ⏩ to confirm.

Selecting a video DVD from the media list

- ▶ Show the menu (▷ page 502).
- ▶ Select **Changer** or **Media** by sliding ⏴ and turning ⏪ the COMAND controller and press ⏩ to confirm.
The media list appears. The ● dot indicates the current medium being played. Video DVDs are indicated by the  icon.
- ▶ **Equipped with a single DVD drive:** press ⏩ the COMAND controller.
COMAND Online loads the video DVD and begins playing it.
- ▶ **Equipped with a DVD changer:** press ⏩ the COMAND controller to display all magazine trays.
- ▶ Select a video DVD by turning ⏪ the COMAND controller and press ⏩ to confirm.
COMAND Online loads the video DVD and begins playing it.

i If you select a CD, an audio DVD or an MP3 medium, you switch to the respective audio mode.

Further information on the media list (▷ page 465).



DVD menu

Calling up the DVD menu

The DVD menu is the menu stored on the DVD itself. It is structured in various ways according to the individual DVD and permits certain actions and settings.





In the case of multi-language DVDs, for example, you can change the DVD language in the DVD menu.

- ▶ Show the menu (▷ page 502).
- ▶ Select **DVD-Video** in the menu by turning ⏪ the COMAND controller and press ⏩ to confirm.



- ▶ Select **DVD functions** and press  to confirm.
- ▶ Select **Menu** and press  to confirm. The DVD menu appears.

Selecting menu items in the DVD menu





- ▶ Show the DVD menu (> page 504).
- ▶ Select a menu item by sliding    the COMAND controller and press  to confirm.

or

- ▶ Select a menu item by sliding   the COMAND controller and press  to confirm. The menu appears.



- ▶ **To reconfirm your selection:** confirm **Select** by pressing . COMAND Online carries out the action. Make a selection from the further options, if necessary. COMAND Online then switches back to the DVD menu.

- i** Menu items that cannot be selected are shown in grey.
- i** Depending on the DVD, the menu items: **Back (to the movie)**, **Play**, **Stop**, ,  or **Go up** may either not function at all or may not function at certain points in the DVD menu. To indicate this, the  symbol appears in the display.

Moving up one level in the DVD menu

- ▶ Show the DVD menu (> page 504).
- ▶ Select the corresponding menu item in the DVD menu and press  the COMAND controller to confirm.

or

- ▶ Select any menu item in the DVD menu and press  the COMAND controller to confirm.
- ▶ Select **Go up** and press  to confirm.

Going back to the film





- ▶ Press the  back button repeatedly until you see the movie.

or

- ▶ Select the corresponding menu item from the DVD menu.
- ▶ Select the **Back (to the movie)** menu item in the menu and press  to confirm.

Setting the language and audio format

This function is not available on all DVDs. If it is available, you can set the DVD menu language, the audio language or the audio format. The number of settings is dependent on the DVD content. It is possible that the settings may also be accessed in the DVD menu (> page 504).

- ▶ Show the DVD menu (> page 504).
- ▶ In full-screen mode, press  the COMAND controller to show the menu.
- ▶ Select **DVD-Video** in the menu by turning  the COMAND controller and press  to confirm.
- ▶ Select **DVD functions** and press  to confirm.

- ▶ Select **Menu language** or **Audio language** and press to confirm.
In both cases, a menu appears after a few seconds. The • dot in front of an entry indicates the currently selected language.
- ▶ Select a setting by turning the COMAND controller and press to confirm.

Subtitles and camera angle

These functions are not available on all DVDs. The number of subtitle languages and camera angles available depends on the content of the DVD. It may also be possible to access the settings from the DVD menu.

- ▶ Activate the DVD menu (▷ page 504).
- ▶ Select **DVD-Video** in the menu by turning the COMAND controller and press to confirm.
- ▶ Select **DVD functions** and press to confirm.
- ▶ Select **Subtitles** or **Camera angle** and press to confirm.
In both cases, a menu appears. The • dot in front of an entry indicates the current setting.
- ▶ Select a setting by turning the COMAND controller and press to confirm.

Interactive content

DVDs can contain interactive content (e.g. a video game). In a video game, for example, you may be able to influence events by selecting and triggering actions. The type and number of actions depend on the DVD.

- ▶ Select an action by sliding or the COMAND controller and press to execute it.
A menu appears and the first entry, **Select**, is highlighted.
- ▶ Press the COMAND controller.

Video AUX operation

Connecting external video sources

WARNING

External video sources may have different volumes, which can mean that system messages such as traffic announcements and navigation system announcements are much louder. If necessary, please deactivate the system messages or adjust their volume manually.

If your vehicle is equipped with the Media Interface, you can connect an external video source.

You require an additional audio/video cable set to connect an external video source to the Media Interface.

For more details, please contact a Mercedes-Benz Service Centre or visit <http://www.mercedes-benz.com/connect>. Then, follow the instructions in the "Media Interface" section.

You will find the connection sockets in the centre console stowage compartment.

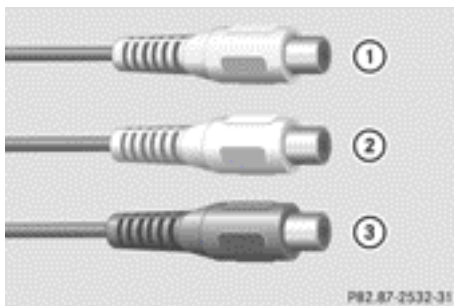

Audio/video sockets

- ① Video port (V) (yellow)
- ② Audio port (L) (white)
- ③ Audio port (R) (red)

For correct playback, a suitable video standard must be set at the external video source.

- ▶ Connect the external device to the corresponding port.

Switching to video AUX mode



Video AUX mode

- ▶ Press the **DISC** function button repeatedly until Media Interface mode is selected.

or

- ▶ Select **Video** in the main function bar by sliding **↑** and turning **⌚** the COMAND controller and press **⌚** to confirm. If video AUX mode was the last mode selected, it will now be active.

If another video source is switched on, you can now switch to video AUX mode in the video menu.

- ▶ Select **Video** and press **⌚** to confirm.
- ▶ Select **Aux** and press **⌚** to confirm. The video AUX menu appears. You will hear and see the content of the external video source if it is connected and switched to playback.

Showing/hiding the menu

- ▶ **To show:** in video AUX mode, press **⌚** the COMAND controller.
- ▶ **To hide:** slide **↑** the COMAND controller and confirm **Full screen** by pressing **⌚**.

Volume and sound settings

Information on:

- volume settings (▷ page 294)
- sound settings (▷ page 294)

⚠ WARNING

External video sources may have different volumes, which can mean that system messages such as traffic announcements and navigation system announcements are much louder. If necessary, please deactivate the system messages or adjust their volume manually.

- ⓘ A device which is connected as an external video source may seem quieter or louder in the vehicle, or the usual maximum volume cannot be achieved. On some devices, it is possible to adjust the volume separately. In this case, start at a medium volume and increase it gradually. This enables you to determine whether the system is able to play the sound at high volume without distorting it.

Increasing the volume on COMAND Online

- ▶ Show the video AUX menu (▷ page 507).
- ▶ Select **Volume** by turning **⌚** the COMAND controller and press **⌚** to confirm. A menu appears. The **•** dot indicates the current setting.
- ▶ Select **Standard** or **Boost** and press **⌚** to confirm.
 - Standard:** the volume of the external video source is adjusted to a standard value.
 - Boost:** the volume of the external video source is raised by approximately 10 dB.

Picture viewer

Introduction

If there are pictures on the active data medium, you can view them. You can display pictures with a resolution of up to 20 megapixels.

Data medium	Supported picture formats
CD/DVD with picture files	jpeg, jpg
USB devices (sticks, hard drives)	jpeg, jpg
SD memory card	

Calling up the category list

- ▶ Select a data medium with pictures (e.g. a memory card):
 - In the Audio menu (▷ page 453)
 - In the media list (▷ page 465)
- ▶ Select **Search** in the basic display by sliding $\odot \downarrow$ and turning $\left\{ \odot \right\}$ the COMAND controller and press \odot to confirm. The category list appears (▷ page 472).

Displaying pictures

- ▶ Select (▷ page 472) **Photos** in the category list by turning $\left\{ \odot \right\}$ the COMAND controller and press \odot to confirm. A folder directory appears.
- ▶ Select a folder with photos and press \odot to confirm. The folder displays the existing picture files (example).

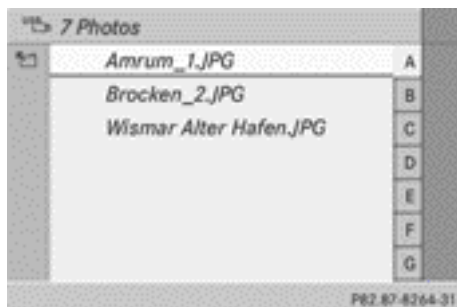

- ▶ Select a photo and press \odot to confirm. The photo is displayed and the music is stopped.



Changing the picture view

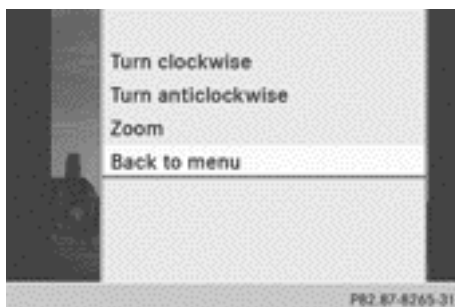



- ▶ While viewing a picture (▷ page 508), press \odot the COMAND controller. A menu appears.
 - ▶ **To turn the picture clockwise:** confirm **Turn clockwise** by pressing \odot the COMAND controller.
 - ▶ **To turn the picture anti-clockwise:** select **Turn anticlockwise** by turning $\left\{ \odot \right\}$ the COMAND controller and press \odot to confirm.
 - ▶ **To zoom into a picture:** select **Zoom** by turning $\left\{ \odot \right\}$ the COMAND controller and press \odot to confirm. After you have zoomed into the picture, you can move the section of the picture.
 - ▶ Slide $\uparrow \odot \downarrow$ and $\leftarrow \odot \rightarrow$ the COMAND controller.

- ▶ **To revert to the original size:** press  the COMAND controller.



or

- ▶ Press the  back button.

Exiting the picture viewer

- ▶ Select **Back to menu** in the menu by turning  the COMAND controller and press  to confirm.



- ▶ **To start playing music:** confirm **Search** by pressing .
The category list appears (▷ page 472).
- ▶ Select a category by turning  the COMAND controller and press  to confirm.
- ▶ Select other entries within the category (e.g. track, album) until the music starts playing.

Useful information	512
Stowage areas	512
Features	516

Useful information

- i** This Owner's Manual describes all models, series and optional equipment for your vehicle that were available at the time of going to press. National variations are possible. Note that your vehicle may not be equipped with all of the functions described. This is also the case for systems and functions relevant to safety.
- i** Read the information on qualified specialist workshops: (▷ page 38).

Stowage areas

Stowage compartments

Important safety notes

⚠ WARNING

If you do not correctly store objects in the vehicle interior, they can slip or be flung around, thus striking vehicle occupants. There is a risk of injury, especially when braking or abruptly changing directions.

- Always store objects so that they cannot be flung around in these or in similar situations.
- Always make sure that objects do not protrude from stowage compartments, luggage nets or stowage nets.
- Close lockable stowage compartments while driving.
- Stow and secure objects that are heavy, hard, pointy, sharp-edged, fragile or too large in the boot.

Glove compartment

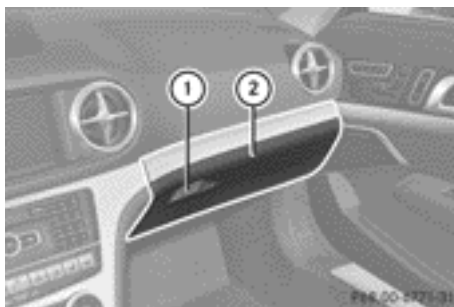

- ▶ **To open:** pull handle ① and open glove compartment flap ②.
- ▶ **To close:** fold glove compartment flap ② upwards until it engages.

In the glove compartment, there is a coin holder, a map holder and a pen holder.

- i** The glove compartment can be ventilated (▷ page 149).

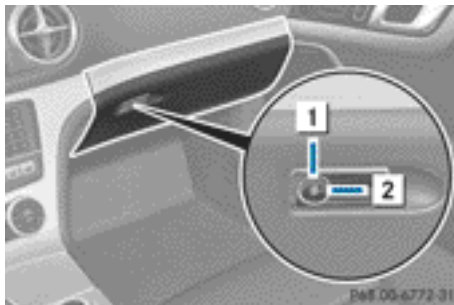

The glove compartment can be locked and unlocked using the emergency key element.

- ▶ **To lock:** insert the emergency key element into the lock and turn it to position ②.
- ▶ **To unlock:** insert the emergency key element into the lock and turn it to position ①.

Stowage compartment/telephone compartment under the armrest

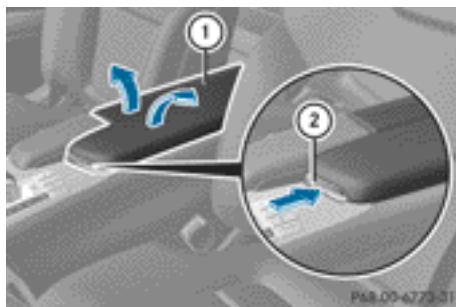

- ▶ **To open:** press button (2).
Armrest (1) opens.

In the stowage compartment, there is a stowage tray and a mobile phone bracket.

- i** Depending on the vehicle's equipment, a 12 V socket, a USB port and an AUX-IN connection or Media Interface are installed in the stowage compartment. Media Interface is a universal interface for mobile audio equipment, e.g. for an iPod® or MP3 Player (▶ page 485).

Spectacles compartment

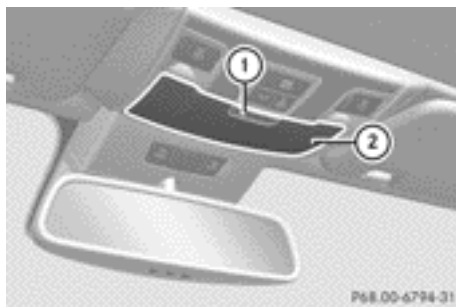

- ▶ **To open:** press marking (1).
Spectacles compartment (2) opens.

Make sure that the spectacles compartment is always closed while the vehicle is in motion.

Stowage compartment in the centre console

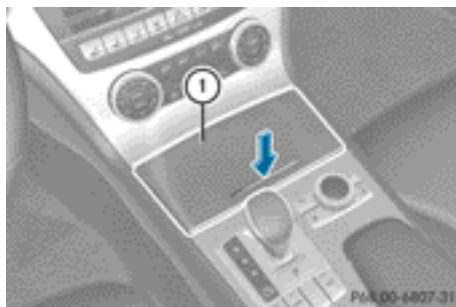

- ▶ **To open:** press the trim element on cover (1).
- ▶ **To remove the rubber mat:** grasp the tabs on the rubber mat and pull up to remove.
- ▶ **To insert the rubber mat:** press the rubber mat into the housing.
- ▶ **To close:** swing cover (1) downwards until it engages.

You can remove the rubber mat from the stowage compartment to clean it. Clean it with clean, lukewarm water only.

Depending on the vehicle's equipment, there is a cup holder and an ashtray in the centre console stowage compartment.

Umbrella holder

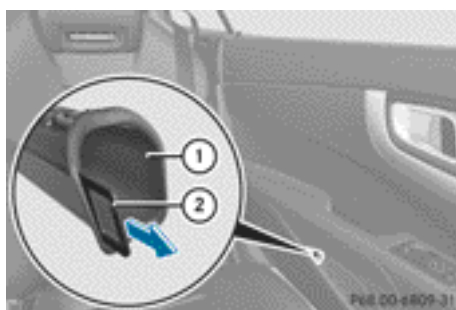

Vehicle side, left (example)

There are umbrella holders in the door stowage compartments on both sides of the vehicle. One compact umbrella can be stowed per side.

- ▶ **To remove:** grab strap ② and pull umbrella holder ① out of the stowage compartment in the direction of the arrow.
- ▶ **To insert:** push umbrella holder ① in the opposite direction to the arrow, into the stowage compartment, until it engages.

You can remove the umbrella holder to clean it. Clean it with clean, lukewarm water only.

Stowage compartment in the rear centre console

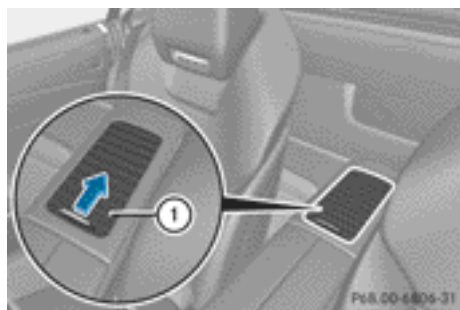

- ▶ **To open:** slide cover ① in the direction of the arrow.

On vehicles equipped with a fire extinguisher, the fire extinguisher is fitted in the stowage compartment (▷ page 545).

On vehicles equipped with a bottle holder, the bottle holder is located in the stowage compartment (▷ page 517).

Stowage compartment in the rear compartment

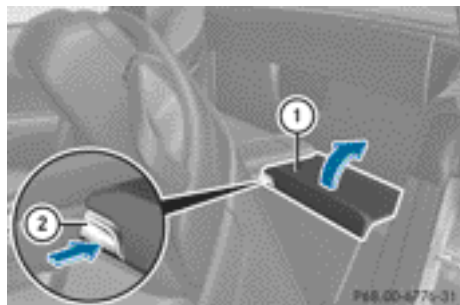

There is a stowage compartment in the rear on the left-hand side only.

- ▶ Open the seat belt guide and remove the seat belt (▷ page 115).
- ▶ Move the left-hand front seat forwards (▷ page 115) and fold the backrest forwards.
- ▶ **To open:** press release button ②. Cover ① folds upwards.
- ▶ **To close:** fold down cover ① and let it engage.
- ▶ Fold the backrest of the left-hand front seat back and move the seat backwards (▷ page 115).
- ▶ Route the seat belt back through the seat belt guide.

Stowage net

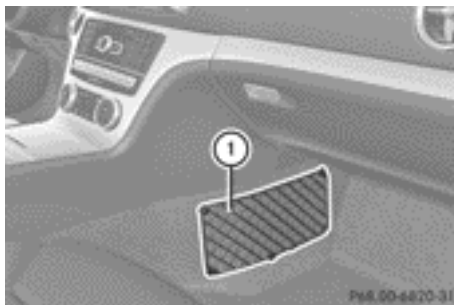

There is a stowage net ① in the front-passenger footwell.

Loading aid in the boot

Raising/lowering the roof

⚠ WARNING

Body parts can become trapped when the roof is being raised or lowered. There is a risk of injury.

When raising or lowering the roof, make sure that no parts of the body are in the vicinity of moving parts. Press the switch again if someone becomes trapped.

! Only close the boot once the roof is lowered completely. Otherwise, you could damage the roof.

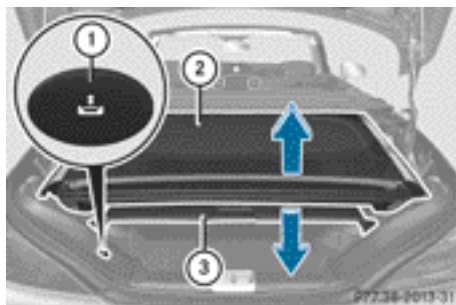

To make it easier to load your luggage, you can raise the stowed roof after you have opened the boot lid.

You can only raise roof ② if boot separator ③ is closed and the boot lid is opened completely.

- ▶ **To raise the roof:** press switch ①.
The roof is raised slightly. Switch ① lights up brightly.
- ▶ Slide boot separator ③ back
(▷ page 105).

You can only lower roof ② if boot separator ③ is closed and the boot lid is opened completely.

- ▶ **To lower the roof:** close the boot separator (▷ page 105).
- ▶ Press switch ①.
The roof is lowered slightly. Switch ① lights up dimly.

Vehicles with boot lid remote closing feature: when the boot lid is opened, the loading aid raises automatically. It lowers automatically when the boot lid is closed.

Problems with the loading aid

Problem	Possible causes/consequences and ► Solutions
It is no longer possible to lower the stowed roof in the boot using the loading aid.	You cannot close the boot any more. ► Call a qualified specialist workshop.

Stowage well under the boot floor

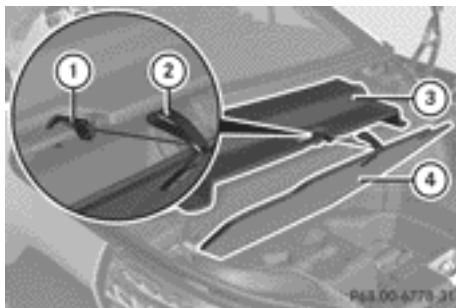

- **To open:** open boot separator ③ (► page 105).
- Swing boot floor ④ up by loop ②.
- Pull hook with Velcro attachment ① off the underside of boot floor ④.
- Attach hook with Velcro attachment ① to boot separator ③ by its handle.

The TIREFIT kit, tyre-change tool kit, etc. are located in the stowage compartment.

Features

Cup holders

Important safety notes

- ❗ Only use the cup holders for containers of the right size and which have lids. The drinks could otherwise spill.

Cup holder in the centre console

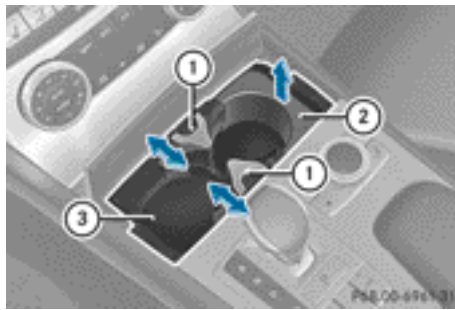

- **To open:** open stowage compartment ③ (► page 513).
- **To remove the insert:** slide catches ① inwards in the direction of the arrow.
- Remove the cup holder insert upwards.
- **To refit the insert:** place the insert in stowage compartment ③.
- Slide catches ① outwards in the direction of the arrow until they engage.

You can remove the rubber mat of the cup holder to clean it. Wash it with clean, luke-warm water only.

Reducer ② can be removed. In this way, you can place large and small containers in the cup holder.

- **To remove:** grip reducer ② and pull out upwards in the direction of the arrow.
- **To insert:** place reducer ② into the cup holder and push it downwards against the direction of the arrow to the stop.

Bottle holders

Observe the "Important safety notes" in the "Stowage compartments" section (▷ page 512).

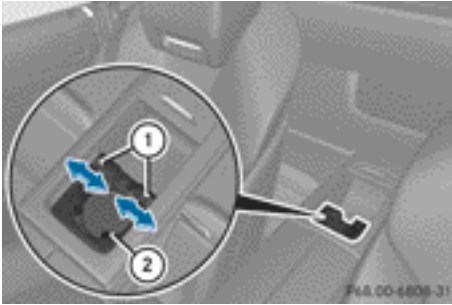

- ▶ **To open:** open the stowage compartment (▷ page 514).
- ▶ **To remove the insert:** slide catches ① inwards in the direction of the arrow.
- ▶ Lift bottle holder insert ② up and remove.
- ▶ **To refit the insert:** place insert ② in the stowage compartment.
- ▶ Slide catches ① outwards in the direction of the arrow until they engage.

The bottle holder does not secure bottles; it merely prevents them from tipping over.

Sun visors

Overview

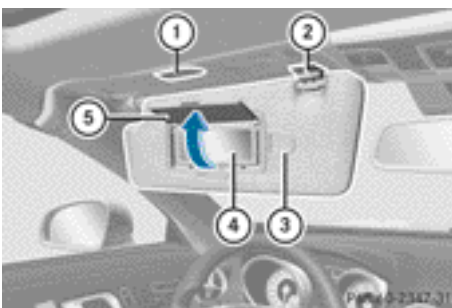

- ① Mirror light
- ② Bracket
- ③ Retaining strip, e.g. for a car park ticket

- ④ Vanity mirror
- ⑤ Mirror cover

Vanity mirror in the sun visor

Mirror light ① only functions if the sun visor is clipped into retainer ② and mirror cover ⑤ has been folded up.

Glare from the side

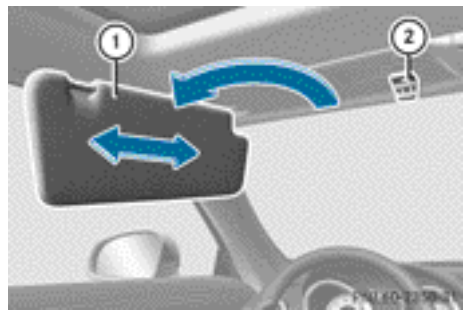

- ▶ Fold down sun visor ①.
- ▶ Pull sun visor ① out of retainer ②.
- ▶ Swing sun visor ① to the side.
- ▶ Slide sun visor ① horizontally as required.

Ashtray

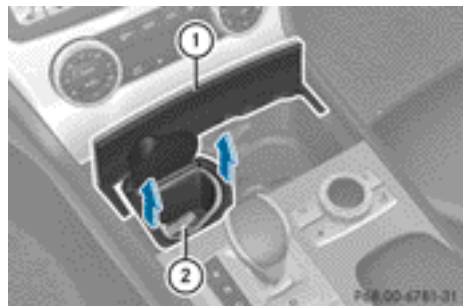

- ▶ **To open:** open stowage compartment ① (▷ page 513).
 - ▶ **To remove the insert:** pull insert ② up in the direction of the arrow, out of the cup holder.
 - ▶ **To refit the insert:** push insert ② on the left-hand side into the cup holder.
- i** Only refit insert ② on the left-hand side of the cup holder.

Cigarette lighter

WARNING

You can burn yourself if you touch the hot heating element or the socket of the cigarette lighter.

In addition, flammable materials can ignite if:

- the hot cigarette lighter falls
- a child holds the hot cigarette lighter to objects, for example

There is a risk of fire and injury.

Always hold the cigarette lighter by the knob. Always make sure that the cigarette lighter is out of reach of children. Never leave children unattended in the vehicle.

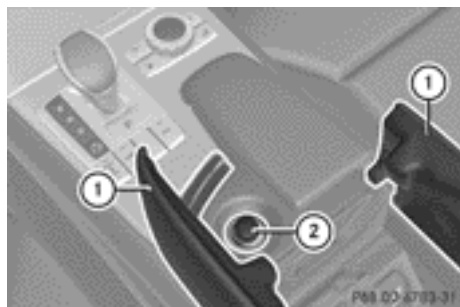

Your attention must always be focused on the traffic conditions. Only use the cigarette lighter when road and traffic conditions permit.

- ▶ Turn the key to position **2** in the ignition lock (▷ page 153).
- ▶ **To open:** open stowage compartment ① under the armrest (▷ page 513).
- ▶ Press in cigarette lighter ②. Cigarette lighter ② will pop out automatically when the heating element is red-hot.

12 V sockets

General notes

- ▶ Turn the key to position **1** in the ignition lock (▷ page 153).

The sockets can be used for accessories with a maximum draw of 180 W (15 A). Accessories include such items as lamps or chargers for mobile phones.

If you use the sockets for long periods when the engine is switched off, the battery may discharge.

- i** An emergency cut-off ensures that the on-board voltage does not drop too low. If the on-board voltage is too low, the power to the sockets is automatically cut. This ensures that there is sufficient power to start the engine.

Socket in the front-passenger footwell

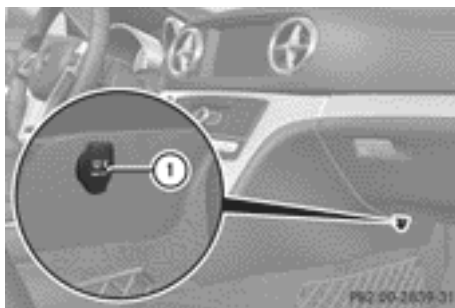

- ▶ Lift up the cover of socket ①.

Socket under the armrest

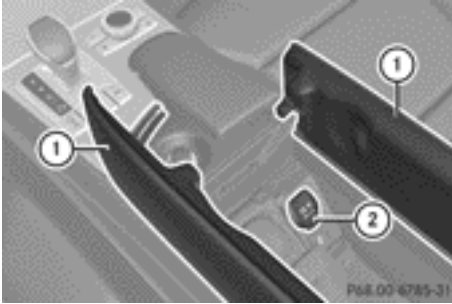

- ▶ Open the stowage compartment under armrest ① (▷ page 513).
- ▶ Lift up the cover of socket ②.

Socket in the boot

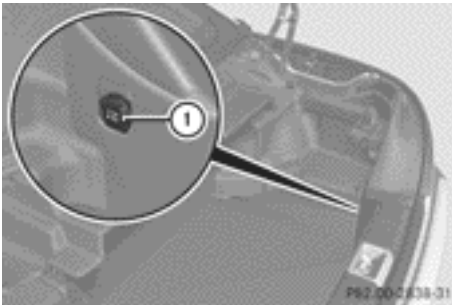

- ▶ Lift up the cover of socket ①.

Mobile phone

Important safety notes

WARNING

Operating mobile communications equipment while driving distracts you from paying attention to traffic conditions. This could also cause you to lose control of the vehicle. There is a risk of an accident.

Use this device only when the vehicle is stationary.

-  You must observe the legal requirements for the country in which you are currently

driving when operating mobile communications equipment in the vehicle.

If it is permitted by law to operate communications equipment while the vehicle is in motion, you may only do so if the traffic situation permits. You may otherwise be distracted from the traffic conditions, cause an accident and injure yourself and others.

Excessive levels of electromagnetic radiation may cause damage to your health and to the health of others. The use of an exterior aerial takes into consideration the scientific discussion surrounding the possible health risk posed by electromagnetic fields.

Mercedes-Benz recommends the use of an approved exterior aerial. This ensures:

- optimal mobile phone reception quality in the vehicle
- mutual influences between the vehicle electronics and mobile phones are minimised

An exterior aerial has the following advantages:

- it conducts the electromagnetic fields generated by a wireless device to the exterior.
- the field strength in the vehicle interior is lower than in a vehicle that does not have an exterior aerial.

Information on retrofitting two-way radios and mobile phones (RF transmitters) (▷ page 585).

General notes

There are various mobile phone brackets that may be fitted in your vehicle; in some cases, these are country-specific.

You can connect a Bluetooth®-capable mobile phone with COMAND Online through the Bluetooth® interface. This also applies if your vehicle is equipped with convenience telephony.

More information on suitable mobile phones, mobile phone brackets and on connecting Bluetooth®-capable mobile phones with COMAND Online can be obtained:

- at your Mercedes-Benz Service Centre
- on the Internet at <http://www.mercedes-benz.com/connect>

i The functions and services available when you use the phone depend on your mobile phone model and service provider.

Using a mobile phone



If the mobile phone is inserted in the mobile phone bracket, you can speak to the person you are calling using the hands-free system.

- ▶ Open the telephone compartment (> page 513).
- ▶ Place the mobile phone bracket into the pre-installed fitting (see the separate installation instructions for the mobile phone fitting).
- ▶ Insert the mobile phone into the mobile phone bracket (see the separate installation instructions for the mobile phone fitting).

i On some mobile phone brackets, you first have to connect the mobile phone to the mobile phone bracket via Bluetooth® (see the separate operating instructions for the mobile phone bracket).

If this is the case, the mobile phone does not have to be inserted into the bracket for you to be able to use the telephone functions. However, the charging function and aerial function are not available.

Operating the mobile phone

You can operate the telephone using the  and  buttons on the multifunction steering wheel. You can operate other mobile phone functions via the on-board computer (> page 229).

When you remove the key from the ignition lock, the mobile phone stays switched on.

However, you can no longer use the hands-free system.

If you have an active call and would like to take the key out of the ignition lock, first remove the mobile phone from the bracket.

i If you use a mobile phone bracket which is connected to your mobile via Bluetooth® and you wish to continue a call on your mobile phone:

You should switch the call to "Private mode" before you remove the key from the ignition lock. Otherwise, it will take up to 20 seconds for the mobile phone to disconnect from the system. Only then can you continue the call on your mobile phone. Notes on the necessary steps for setting "Private mode" can be found in the separate operating instructions of the mobile phone.

i Not all mobile phones support "Private mode".

Charge maintenance socket

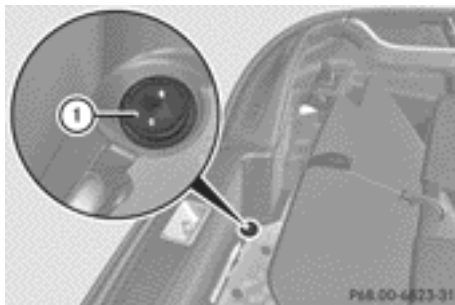

The battery may drain if the vehicle is left stationary for long periods. In this case, Mercedes-Benz recommends attaching the trickle charger to charge maintenance socket ①.

Charge maintenance socket ① is designed solely for connecting a trickle charger. A trickle charger can be obtained from a Mercedes-Benz Service Centre, for example.

- ▶ Switch the ignition off.
- ▶ Open the boot lid.
- ▶ Open the stowage well under the boot floor (▷ page 516).
- ▶ Connect the trickle charger to charge maintenance socket ①. Consult the manufacturer's operating instructions on how to do so.

The boot lid can be closed, even if a trickle charger is connected. Make sure that the connector for both the connector cables is outside of the vehicle.

The connector can then separate if the vehicle is moved, even if you forget to disconnect the connector cables. This prevents damaging the cables and the trickle charger.

- ❗ A trickle charger connected to charge maintenance socket only maintains the current charge level of the vehicle's electrical system battery. If the vehicle's electrical system battery is discharged, it needs to be charged with a battery charger. You will find further information on charging the battery on (▷ page 550).

the engine running in enclosed spaces without sufficient ventilation.

The HomeLink® garage door opener integrated in the rear-view mirror allows you to operate up to three different door and gate systems.

When programming a garage door opener, park the vehicle outside the garage.

- ❗ The garage door opener is only available for certain countries. Observe the legal requirements for each individual country.

The HomeLink® garage door opener is compatible with most European garage and gate opener drives. More information on HomeLink® and/or compatible products is available from:

- at a qualified specialised workshop
- the HomeLink® hotline (0) 08000 466 354 65 (free of charge) or +49 (0) 6838 907 277 (charges apply)
- on the Internet at: <http://www.homelink.com>

Garage door opener

Important safety notes

⚠ WARNING

When you operate or program the garage door with the integrated garage door opener, persons in the range of movement of the garage door can become trapped or struck by the garage door. There is a risk of injury.

When using the integrated garage door opener, always make sure that nobody is within the range of movement of the garage door.

⚠ WARNING

Combustion engines emit poisonous exhaust gases such as carbon monoxide. Inhaling these exhaust gases leads to poisoning. There is a risk of fatal injury. Therefore never leave

Programming

Programming buttons

Observe the "Important safety notes" (▷ page 521).

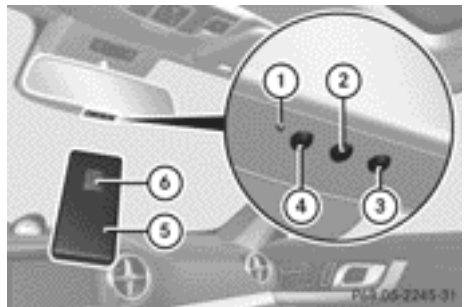

Integrated garage door opener in the rear-view mirror

Garage door remote control ⑤ is not part of the integrated garage door opener.

- ▶ Before programming for the first time, clear the memory of the integrated garage door opener (▷ page 523).
- ▶ Turn the key to position **2** in the ignition lock.
- ▶ Press and hold one of buttons **②** to **④** on the integrated garage door opener. After a short time, indicator lamp **①** begins to light up yellow.
- i** Indicator lamp **①** lights up yellow immediately the first time button **②**, **③** or **④** is programmed. If the selected button has already been programmed, indicator lamp **①** lights up yellow after ten seconds have elapsed.
- ▶ Release button **②**, **③** or **④**. Indicator lamp **①** flashes yellow.
- ▶ Point garage door remote control **⑤** towards buttons **②** to **④** on the rear-view mirror at a distance of 5 to 20 cm.
- i** The required distance between remote control **⑤** and the integrated garage door opener depends on the garage door drive system. Several attempts may be required. You should test every position for at least 25 seconds before trying another position.
- ▶ Press and hold button **⑥** on remote control **⑤** until indicator lamp **①** lights up green. If indicator lamp **①** lights up green or flashes, then programming has been successful.
- ▶ Release button **⑥** of remote control **⑤** of the garage door drive.
- ▶ If indicator lamp **①** blinks red: repeat the programming process for the corresponding button on the rear-view mirror. When doing so, vary the distance between remote control **⑤** and the rear-view mirror.
- i** If the indicator lamp flashes green after successful programming, the garage door system is using a rolling code. After programming, you must synchronise the garage door opener integrated in the rear-

view mirror with the receiver of the garage door system.

Synchronising the rolling code

Observe the "Important safety notes" (▷ page 521).

Your vehicle must be within range of the garage door or exterior gate drive. Make sure that neither your vehicle nor any persons/objects are present within the sweep of the door or gate.

- ▶ Turn the key to position **2** in the ignition lock.
- ▶ Press the programming button of the door or gate drive (see the door or gate drive operating instructions, e.g. under "Programming of additional remote controls").
- i** Usually, you now have 30 seconds to initiate the next step.
- ▶ Press previously programmed button **②**, **③** or **④** of the integrated garage door opener until the door closes. The rolling code synchronisation is then complete.

Problems when programming

If you have problems when programming the integrated garage door opener, please note the following:

- Check the transmitter frequency of garage door drive remote control **⑤**. This can usually be found on the back of the remote control.
- Replace the batteries in garage door remote control **⑤**. This increases the likelihood that garage door remote control **⑤** will transmit a strong and precise signal to the integrated garage door opener in the rear-view mirror.
- When programming, hold remote control **⑤** at varying distances and angles from the button which you are programming. Try various angles at a distance between 5 and 30 cm or at the same angle but at varying distances.

- If there is another remote control for the same garage door drive, perform the programming steps again using this remote control. Before performing these steps, make sure that new batteries have been fitted in garage door drive remote control ⑤.
- Note that some remote controls transmit only for a limited period (the indicator lamp on the remote control goes out). Press button ⑥ on remote control ⑤ again before transmission ends.
- Align the aerial cable of the garage door opener unit. This can improve signal reception/transmission.

Opening or closing the garage door

Once programmed, the integrated garage door opener will assume the function of the garage door system's remote control. Please also read the operating instructions for the garage door system.

- ▶ Turn the key to position **2** in the ignition lock.
- ▶ Press button ②, ③ or ④ which you have programmed to operate the garage door. Garage door system with a fixed code: indicator lamp ① lights up green.
Garage door system with a rolling code: indicator lamp ① flashes green.

- ① The transmitter will transmit a signal for as long as the button is pressed. The transmission is halted after a maximum of ten seconds and indicator lamp ① lights up yellow. Press button ②, ③ or ④ again if necessary.

Clearing the memory

- ▶ Turn the key to position **2** in the ignition lock.
- ▶ Press buttons ② and ④.
The indicator lamp lights up yellow.
- ▶ Press and hold buttons ② and ④ until the indicator lamp turns green.

- ① Make sure that you clear the memory of the integrated garage door opener before selling the vehicle.

Frequencies

Europe

Country	Radio type approval number Frequency range (MHz)
AD (Andorra)	20 July MHz: 27, 30, 40, 433, 868
AT (Austria)	Article 6 of Directive 1999/5/EC R&TTE 18 May 05 MHz: 27, 40, 433, 868
BE (Belgium)	Article 6 of Directive 1999/5/EC R&TTE 18 May 05 MHz: 27, 40, 433, 868
BG (Bulgaria)	Article 6 of Directive 1999/5/EC R&TTE 12 April 07 MHz: 27, 40, 433, 868
CH (Switzerland)	Article 6 of Directive 1999/5/EC R&TTE 14357 27 May 05 MHz: 27, 40, 433, 868
CY (Cyprus)	Article 6 of Directive 1999/5/EC R&TTE 5 May 05 MHz: 27, 40, 433, 868
CZ (Czech Republic)	General Licence GL-30/R/ 2000 Reg No. 844 13 May 05 MHz: 27, 40, 433
DK (Denmark)	Article 6 of Directive 1999/5/EC R&TTE 20 April 05 MHz: 27, 40, 433, 868

Country	Radio type approval number Frequency range (MHz)
DE (Germany)	Article 6 of Directive 1999/5/EC R&TTE7519301 29 April 05 MHz: 27, 40, 433, 868
EE (Estonia)	Article 6 of Directive 1999/5/EC R&TTE 11 May 05 MHz: 27, 40, 433, 868
ES (Spain)	000438/2005, 000439/2005, 000440/2005 000441/2005, 000445/2005, 000446/2005 000447/2005 MHz: 27, 40, 433, 868
FI (Finland)	Article 6 of Directive 1999/5/EC R&TTE10668 13 May 05 MHz: 27, 40, 433, 868
FR (France)	Article 6 of Directive 1999/5/EC R&TTE10668 13 May 05 27, 30, 40, 433, 868
GI (Gibraltar)	Article 6 of Directive 1999/5/EC R&TTE13 May 05 (UK) MHz: 27, 40, 418, 433, 868
GR (Greece)	Article 6 of Directive 1999/5/EC R&TTE11409/18/4/2005 18 May 05 MHz: 27, 40, 433, 868
HR (Croatia)	SDR 224/06 MHz: 27, 40, 433, 868

Country	Radio type approval number Frequency range (MHz)
HU (Hungary)	Article 6 of Directive 1999/5/EC R&TTE 18 May 05 MHz: 27, 40, 433, 868
IC (Canary Islands)	000438/2005, 000439/2005 000440/2005, 000441/2005 000445/2005, 000446/2005 000447/2005, 3rd June 2005 MHz: 27, 40, 433, 868
IE (Ireland)	Article 6 of Directive 1999/5/EC R&TTE 18 May 05 MHz: 27, 40, 433, 868
IS (Iceland)	Article 6 of Directive 1999/5/EC R&TTE 18 May 05 MHz: 27, 40, 433, 868
IT (Italy)	DGPGSR/II/347487/ FOR/15347 DGPGSR/II/347487/ FOR/15348 DGPGSR/II/347487/ FOR/15350 DGPGSR/II/347487/ FOR/15357 DGPGSR/II/347487/ FOR/15358 DGPGSR/II/347487/ FOR/15359 MHz: 27, 40, 433, 868
LI (Liechtenstein)	Article 6 of Directive 1999/5/EC R&TTE 14357 27 May 05 MHz: 27, 40, 433, 868

Country	Radio type approval number Frequency range (MHz)
LT (Lithuania)	Article 6 of Directive 1999/5/EC R&TTE27.4-1B-1609 6 May 05 MHz: 27, 40, 433, 868
LU (Luxembourg)	Article 6 of Directive 1999/5/EC R&TTE150405/9538 24 May 05 MHz: 27, 40, 433, 868
LV (Latvia)	Article 6 of Directive 1999/5/EC R&TTE 27.4-1B-1609 26 April 06 MHz: 27, 40, 433, 868
MC (Monaco)	Article 6 of Directive 1999/5/EC R&TTE10668 13 May 05 MHz: 27, 40, 433, 868
MT (Malta)	Article 6 of Directive 1999/5/EC R&TTE 18 May 05 MHz: 27, 40, 433, 868
NL (Netherlands)	Article 6 of Directive 1999/5/EC R&TTE 18 May 05 MHz: 27, 40, 433, 868
NO (Norway)	Article 6 of Directive 1999/5/EC R&TTE05/02424-SA644 18 May 05 MHz: 27, 40, 433, 868
PL (Poland)	Article 6 of Directive 1999/5/EC R&TTE 21 April 05 MHz: 27, 40, 433, 868
PT (Portugal)	ANCOM-S08399/05 27, 40, 433, 868

Country	Radio type approval number Frequency range (MHz)
RO (Romania)	Article 6.4 of Directive 1999/5/EC R&TTE MHz: 27, 30, 40, 433, 868
RU (Russian Federation)	POCC DE.MJ05.H00015 13 May 05 MHz: 433
SE (Sweden)	Article 6 of Directive 1999/5/EC R&TTE 18 May 05 MHz: 27, 40, 433, 868
SI (Slovenia)	Article 6 of Directive 1999/5/EC R&TTE 500-1/2005-437 9 May 05 MHz: 27, 40, 433, 868
SK (Slovakia)	Article 6 of Directive 1999/5/EC R&TTE Slovak 206/11/2005 4 May 05 MHz: 27, 40, 433, 868
UK (United Kingdom)	Article 6 of Directive 1999/5/EC R&TTE 18 May 05 MHz: 27, 40, 418, 433, 868

Africa

Country	Radio type approval number Frequency range (MHz)
EG (Egypt)	W-KLE-17/08 Mar. 06 MHz: 27, 30, 40, 418, 433, 868
RE (Réunion)	Article 6 of Directive 1999/5/EC R&TTE 11 July 05 MHz: 27, 40, 433, 868
ZA (South Africa)	11 October 2005 MHz: 27, 40, 433

America

Country	Radio type approval number Frequency range (MHz)
BB (Barbados)	Registration not required MHz: 27, 40, 433, 868
CL (Chile)	38447/F-23 No.3.3634 MHz: 40, 433
GF (French Guyana)	Article 6 of Directive 1999/5/EC R&TTE10668 13 May 05 MHz: 27, 30, 40, 433, 868
GP (Guadeloupe)	Article 6 of Directive 1999/5/EC R&TTE10668 13 May 05 MHz: 27, 30, 40, 433, 868
MQ (Martinique)	Article 6 of Directive 1999/5/EC R&TTE 11 July 05 MHz: 27, 30, 40, 433, 868
MX (Mexico)	MHz: 280 to 390

Asia

Country	Radio type approval number Frequency range (MHz)
AE (United Arab Emirates)	1623/5/10-2/26/76 MHz: 433
JO (Jordan)	TRC/LPD/2005/23 MHz: 27, 30, 40, 433, 868
KW (Kuwait)	5 October 2005 MHz: 27, 30, 40, 418, 433, 868
SA (Saudi Arabia)	11_02_05/5024-5-6 MHz: 418, 433
SY (Syria)	279/4/14 / 05 March 06
TR (Turkey)	National Certification 23 July 07 MHz: 433

Australia

Country	Radio type approval number Frequency range (MHz)
AU (Australia)	28 June MHz: 27, 30, 40, 433, 868
NZ (New Zealand)	20 March 06 MHz: 27, 30, 40, 433

Floormats

 **WARNING**

Objects in the driver's footwell can restrict the pedal travel or obstruct a depressed pedal. The operating and road safety of the vehicle is jeopardised. There is a risk of an accident. Make sure that all objects in the vehicle are stowed correctly, and that they cannot enter the driver's footwell. Fit the floormats securely and as specified in order to ensure

sufficient clearance for the pedals. Do not use loose floormats.

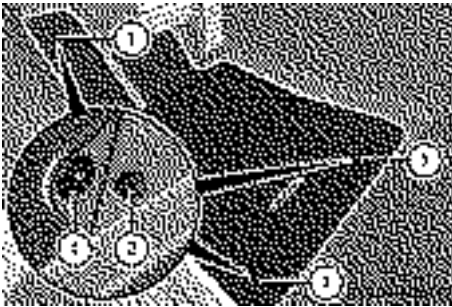

- ▶ Slide the seat backwards.
- ▶ **To fit:** lay the floormat in the footwell.
- ▶ Press studs ① onto retainers ②.
- ▶ **To remove:** pull the floormat from retainers ②.
- ▶ Remove the floormats.

Retrofitted anti-glare film

Retrofitted anti-glare film on the inside of the windows can interfere with radio/mobile telephone reception. This is particularly the case for conductive or metallic-coated films. You can obtain information about anti-glare film from a qualified specialist workshop.

Useful information	530
Engine compartment	530
ASSYST PLUS	534
Care	535

Useful information

- i** This Owner's Manual describes all models, series and optional equipment for your vehicle that were available at the time of going to press. National variations are possible. Note that your vehicle may not be equipped with all of the functions described. This is also the case for systems and functions relevant to safety.
- i** Read the information on qualified specialist workshops: (▷ page 38).

Engine compartment

Bonnet

Important safety notes

WARNING

An unlocked bonnet may open while driving and block your view. There is a risk of an accident.

Never unlock the bonnet while driving.

WARNING

When being opened and closed, the bonnet may suddenly fall into the closed position. There is a risk of injury to persons in the range of movement of the bonnet.

Open and close the bonnet only when nobody is in the range of movement.

WARNING

Certain components in the engine compartment could be very hot, e.g. the engine, the radiator and parts of the exhaust system. There is a risk of injury when accessing the engine compartment.

As far as possible, allow the engine to cool down and only touch the following components.

WARNING

If you open the bonnet while the engine is overheating or while there is a fire in the

engine compartment, you could come into contact with hot gases or other leaking service products. There is a danger of injury. Allow an overheating engine to cool down before opening the bonnet. If there is a fire in the engine compartment, leave the bonnet closed and notify the fire brigade.

WARNING

There are parts in the engine compartment that move. Certain components may continue to run even if the ignition is switched off or may suddenly start again, e.g. the radiator fan. There is a danger of injury.

If you need to access the engine compartment:

- switch off the ignition
- never enter the danger area of moving components, e.g. the rotation area of the fan
- keep items of clothing away from moving parts

Active bonnet (pedestrian protection)

Operating principle

! An active bonnet that had been triggered must be repaired at a qualified specialist workshop. The active bonnet function will then be available again. The additional pedestrian protection provided by the active bonnet will then be restored.

The active bonnet is only available in certain countries.

The active bonnet can reduce the risk of injury to pedestrians in certain accident situations. Raising the active bonnet increases the clearance to hard components, such as the engine. If the active bonnet has been triggered, it is raised at the rear in the area around the hinge by approximately 85 mm. The active bonnet is triggered by pyrotechnics.

For the drive to the workshop, reset the triggered active bonnet yourself. If the active bonnet has been triggered, pedestrian protection may be limited.

Resetting

WARNING

Certain components in the engine compartment could be very hot, e.g. the engine, the radiator and parts of the exhaust system. There is a risk of injury when accessing the engine compartment.

As far as possible, allow the engine to cool down and only touch the following components.

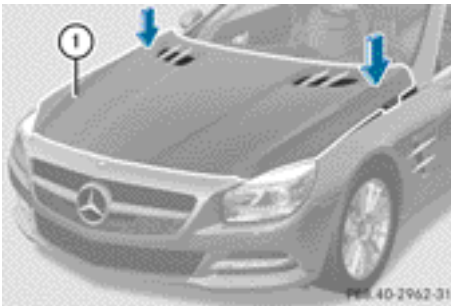

- ▶ With your hand flat, push down active bonnet ① in the area around the hinges on both sides (arrows) until you feel it engage.

If you can raise the active bonnet slightly in the area around the hinges, it is not engaged correctly. Repeat the step.

Opening the bonnet

WARNING

When the bonnet is open, and the windscreen wipers are set in motion, you can be injured by the wiper linkage. There is a risk of injury. Always switch off the windscreen wipers and the ignition before opening the bonnet.

- ▶ **!** Make sure that the windscreen wipers are not folded away from the windscreen. Otherwise, you could damage the windscreen wipers or the bonnet.

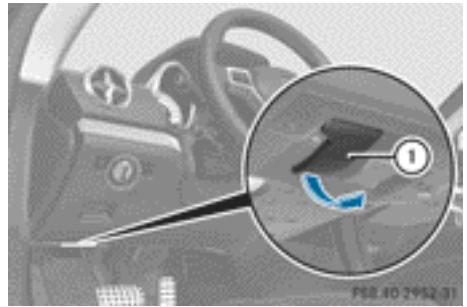

- ▶ Make sure that the windscreen wipers are switched off.
- ▶ Pull release lever ① on the bonnet. The bonnet is released.



- ▶ Reach into the gap, pull bonnet catch handle ② up and lift the bonnet. If you lift the bonnet by approximately 40 cm, the bonnet is opened and held open automatically by the gas-filled strut.

Closing the bonnet

- ▶ Lower the bonnet and let it fall from a height of approximately 20 cm.
- ▶ Check that the bonnet has engaged properly. If the bonnet can be raised slightly, it is not properly engaged. Open it again and close it with a little more force.

Engine oil

Notes on oil level

Depending on your driving style, the vehicle consumes up to 0.8 l of oil per 1,000 km. The oil consumption may be higher than this when the vehicle is new or if you frequently drive at high engine speeds.

Depending on the engine, the oil dipstick may be installed at a different location.

When checking the oil level:

- park the vehicle on a level surface.
- the engine should be switched off for approximately five minutes if the engine is at normal operating temperature.
- if the engine is not at normal operating temperature, e.g. if the engine was only started briefly: wait about 30 minutes before carrying out the measurement.

Checking the oil level using the oil dipstick

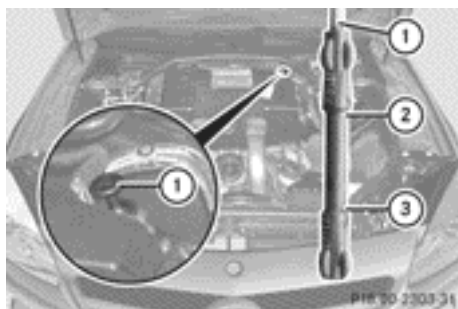

Example

- ▶ Pull oil dipstick ① out of the oil dipstick tube.
- ▶ Wipe off oil dipstick ①.
- ▶ Slowly slide oil dipstick ① into the guide tube to the stop, and take it out again. If the level is between MIN mark ③ and MAX mark ②, the oil level is correct.
- ▶ If the oil level has dropped to MIN mark ③ or below, add 1.0 litre of engine oil.

Adding engine oil

⚠ WARNING

If engine oil comes into contact with hot components in the engine compartment, it may ignite. There is a risk of fire and injury.

Make sure that engine oil does not spill out over the filler neck. Allow the engine to cool down and thoroughly clean the components that have come into contact with engine oil before you start the engine.

♻ Environmental note

When topping up the oil, take care not to spill any. If oil enters the soil or waterways, it is harmful to the environment.

- ❗ Only use engine oils and oil filters that have been approved for vehicles with a service system. You can obtain a list of the engine oils and oil filters tested and approved in accordance with the Mercedes-Benz Specifications for Service Products at any Mercedes-Benz Service Centre.

Damage to the engine or exhaust system is caused by the following:

- using engine oils and oil filters that have not been specifically approved for the service system
- changing the engine oil and oil filter after missing the change interval required by the service system
- using engine oil additives
- ❗ Do not add too much oil. If the oil level is above the "max" mark on the dipstick, too much oil has been added. This can lead to damage to the engine or the catalytic converter. Have excess oil siphoned off.

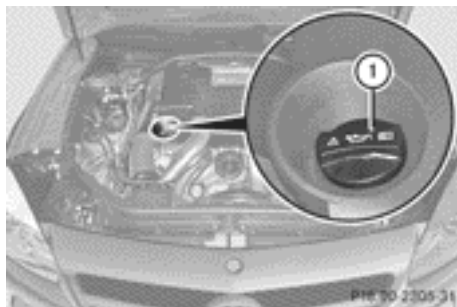

Example: engine oil filler cap

- ▶ Turn cap ① anti-clockwise and remove it.
- ▶ Top up the engine oil.
If the oil level is at or below the MIN mark on the oil dipstick, top up with 1.0 litre of engine oil.
- ▶ Replace cap ① on the filler neck and turn clockwise.
Make sure that the cap locks securely into place.
- ▶ Check the oil level again with the oil dipstick (▷ page 532).

For further information on engine oil, see (▷ page 590).

Checking and adding other service products

Checking the coolant level

⚠ WARNING

The engine cooling system is under pressure, particularly if the engine is warm. You could be scalded by hot coolant spraying out when opening the cap. There is a danger of injury. Allow the engine to cool before opening the cap. Wear gloves and protective eyewear when opening. Slowly turn the cap half a turn to allow pressure to escape.

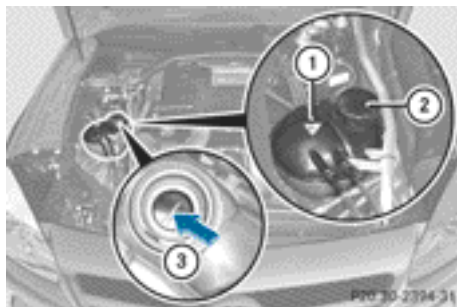

Example

- ▶ Park the vehicle on a level surface.
Only check the coolant level if the vehicle is on a level surface and the engine has cooled down.
- ▶ Turn the key to position 2 in the ignition lock (▷ page 153).
On vehicles with KEYLESS-GO, press the Start/Stop button twice (▷ page 153).
- ▶ Check the coolant temperature gauge in the multifunction display.
The coolant temperature must be below 70 °C.
- ▶ Turn the key to position 0 (▷ page 153) in the ignition lock.
- ▶ Slowly turn cap ② half a turn anti-clockwise to allow excess pressure to escape.
- ▶ Turn cap ② further anti-clockwise and remove it.
If the coolant is at the level of marker bar ③ in the filler neck when cold, there is enough coolant in coolant expansion tank ①.
If the coolant level is approximately 1.5 cm above marker bar ③ in the filler neck when warm, there is enough coolant in coolant expansion tank ①.
- ▶ If necessary, top up with coolant that has been tested and approved by Mercedes-Benz.
- ▶ Replace cap ② and turn it clockwise as far as it will go.

For further information on coolant, see (▷ page 592).

Windscreen washer system and headlamp cleaning system

WARNING

If antifreeze comes into contact with hot components in the engine compartment, it may ignite. There is a risk of fire and injury.

Let the engine cool down before you top up the antifreeze. Make sure that antifreeze is not spilled next to the filler neck. Thoroughly clean the antifreeze from components before starting the engine.

WARNING

Windscreen washer concentrate is highly flammable. If it comes into contact with hot engine components or the exhaust system it could ignite. There is a risk of fire and injury.

Make sure that no windscreen washer concentrate is spilled next to the filler neck.



Example

- ▶ **To open:** pull cap ① upwards by the tab.
- ▶ Top up with the premixed washer fluid.
- ▶ **To close:** press cap ① onto the filler neck until it engages.

The washer fluid reservoir is used for both the windscreen washer system and the headlamp cleaning system.

For further information on the windscreen washer system and headlamp cleaning system, see (▷ page 593).

ASSYST PLUS

Service messages

The ASSYST PLUS service interval display informs you of the next service due date. Information on the type of service and service intervals (see separate Service Booklet). You can obtain further information from a Mercedes-Benz Service Centre.

 The ASSYST PLUS service interval display does not show any information on the engine oil level. Observe the notes on the engine oil level (▷ page 532).

The multifunction display shows a service message for a few seconds, e.g.:

- Next service A due in .. days
- Service A due
- Service A overdue by .. days

Depending on the operating conditions of the vehicle, the remaining time and distance until the next service due date is displayed.

The letter indicates which service is due. **A** stands for a minor service and **B** for a major service. A number or another letter may be displayed after the letter. This figure indicates any necessary additional maintenance work to be performed.

If you notify a qualified specialist workshop of this display, you will receive a statement on the associated costs.

The ASSYST PLUS service interval display does not take into account any periods of time during which the battery is disconnected.

Maintaining the time-dependent service schedule:

- ▶ Note down the service due date displayed in the multifunction display before disconnecting the battery.





or

- ▶ After reconnecting the battery, subtract the battery disconnection periods from the service date shown on the display.

Hiding a service message

- ▶ Press the  or  button on the steering wheel.

Displaying service messages

- ▶ Switch the ignition on.
- ▶ Press the  or  button on the steering wheel to select the **Serv.** menu.
- ▶ Press  or  to select the **ASSYST PLUS** submenu and press  to confirm. The service due date appears in the multi-function display.

Information about Service

Resetting the ASSYST PLUS service interval display

- ❗ If the ASSYST PLUS service interval display has been inadvertently reset, this setting can be corrected at a qualified specialist workshop.

Have service work carried out as described in the Service Booklet. This may otherwise lead to increased wear and damage to the major assemblies or the vehicle.

A qualified specialist workshop, e.g. a Mercedes-Benz Service Centre, will reset the ASSYST PLUS service interval display after the service work has been carried out. You can also obtain further information, for example, on maintenance work.

Special service requirements

The specified maintenance interval takes only the normal operation of the vehicle into account. Under arduous operating conditions or increased load on the vehicle, maintenance work must be carried out more frequently, e.g.

- regular city driving with frequent intermediate stops
- if the vehicle is primarily used to travel short distances
- use in mountainous terrain or on poor road surfaces
- if the engine is often left idling for long periods

Under these or similar conditions, have, for example, the air filter, engine oil and oil filter replaced or renewed more frequently. Under arduous operating conditions, the tyres must be checked more often. Further information can be obtained at a qualified specialist workshop, e.g. a Mercedes-Benz Service Centre.

Driving abroad

An extensive Mercedes-Benz Service network is also available in other countries. The Service Hotline's current telephone numbers for use when you are abroad are to be found in the "Mercedes-Benz Service24h" section of the Service Booklet.

Care

Notes on care

Environmental note

Dispose of empty packaging and cleaning cloths in an environmentally responsible manner.

- ❗ For cleaning your vehicle, do not use any of the following:
 - dry, rough or hard cloths
 - abrasive cleaning agents

- solvents
- cleaning agents containing solvents

Do not scrub.

Do not touch the surfaces or protective films with hard objects, e.g. a ring or ice scraper. You could otherwise scratch or damage the surfaces and protective film.

- !** Do not park up the vehicle for an extended period straight after cleaning it, particularly after having cleaned the wheels with wheel cleaner. Wheel cleaners could cause increased corrosion of the brake discs and brake pads/linings. For this reason, you should drive for a few minutes after cleaning. Braking heats the brake discs and the brake pads/linings, thus drying them. The vehicle can then be parked up.

Regular care of your vehicle is a condition for retaining the quality in the long term.

Use care products and cleaning agents recommended and approved by Mercedes-Benz.

Washing the vehicle and cleaning the paintwork

Automatic car wash

WARNING

Braking efficiency is reduced after the vehicle has been washed. There is a risk of an accident.

After washing the vehicle, brake carefully while paying attention to the traffic conditions in order to restore full braking efficiency.

WARNING

The vehicle is braked when the HOLD function or DISTRONIC PLUS is activated. Therefore, deactivate the HOLD function and DISTRONIC PLUS before the vehicle is washed in an automatic car wash.

- !** It is preferable to use car washes with adjustable high-pressure pre-cleaning that corresponds to the specification for the

Cabriolet programme. In car washes that use high water pressures, there is a risk that a small amount of water may leak into the vehicle.

- !** Vehicles with HANDS-FREE ACCESS: if a key with KEYLESS-GO is within the detection range of the KEYLESS-GO antenna, the following situations could lead to the unintentional opening of the boot lid:

- using a car wash
- using a high-pressure cleaner

Make sure that the key is at least 2 m away from the vehicle.

- !** Make sure that the automatic transmission is in position **N** when washing your vehicle in a tow-through car wash. Other transmission positions may lead to damage to the vehicle.

- !** Make sure that:

- the side windows and roof are completely closed.
- the blower for the ventilation/heating is switched off (OFF button is depressed/ airflow control is turned to position **0**).
- the windscreen wiper switch is at position **0**.

The vehicle could otherwise be damaged.

You can wash the vehicle in an automatic car wash from the very start.

Wash off excess dirt before cleaning the vehicle in an automatic car wash.

After using an automatic car wash, wipe off wax from the windscreen and the wiper blades. This will prevent smears and reduce wiping noises caused by residue on the windscreen.

Washing by hand

In some countries, washing by hand is only allowed at specially equipped washing bays. Observe the legal requirements for each individual country.

- ▶ Do not use hot water and do not wash the vehicle in direct sunlight.
- ▶ Use a soft sponge to clean.
- ▶ Use a mild cleaning agent, such as a car shampoo approved by Mercedes-Benz.
- ▶ Thoroughly hose down the vehicle with a gentle jet of water.
- ▶ Do not point the water jet directly towards the air inlet.
- ▶ Use plenty of water and rinse out the sponge frequently.
- ▶ Rinse the vehicle with clean water and dry thoroughly with a chamois.
- ▶ Do not let the cleaning agent dry on the paintwork.

When using the vehicle in winter, remove all traces of road salt deposits carefully and as soon as possible.

High-pressure cleaning equipment

WARNING

The water jet of circular-jet nozzles (dirt grinders) can cause damage not visible from the outside to tyres or chassis components. Components damaged in this way can unexpectedly fail. There is a risk of an accident.

Do not use high-pressure cleaners with circular-jet nozzles to clean the vehicle. Have damaged tyres or chassis components replaced immediately.

- ❗ Always maintain a distance of at least 30 cm between the vehicle and the high-pressure cleaner nozzle. Information about the correct distance is available from the equipment manufacturer.

Move the high-pressure cleaner nozzle around when cleaning your vehicle.

Do not aim directly at any of the following:

- tyres
- door gaps, roof gaps, joints etc.
- electrical components
- battery
- connectors
- lights
- seals
- trim elements
- ventilation slots

Damaged seals or electrical components can lead to leaks or failures.

- ❗ Vehicles with HANDS-FREE ACCESS: if a key with KEYLESS-GO is within the detection range of the KEYLESS-GO antenna, the following situations could lead to the unintentional opening of the boot lid:

- using a car wash
- using a high-pressure cleaner

Make sure that the key is at least 2 m away from the vehicle.

Cleaning the paintwork

- ❗ Do not affix:

- stickers
 - films
 - magnetic plates or similar items
- to painted surfaces. You could otherwise damage the paintwork.

Scratches, corrosive deposits, areas affected by corrosion and damage caused by inadequate care cannot always be completely repaired. In such cases, visit a qualified specialist workshop.

- ▶ Remove impurities immediately, where possible, whilst avoiding rubbing too hard.
- ▶ Soak insect remains with insect remover and rinse off the treated areas afterwards.
- ▶ Soak bird droppings with water and rinse off the treated areas afterwards.
- ▶ Remove coolant, brake fluid, tree resin, oils, fuels and greases by rubbing gently with a cloth soaked in petroleum ether or lighter fluid.
- ▶ Use tar remover to remove tar stains.
- ▶ Use silicone remover to remove wax.

Care and treatment of matt paintwork

! Never polish the vehicle or the light alloy wheels. Polishing makes the paintwork shiny.

! The following may cause the paint to become shiny and thus reduce the matt effect:

- Vigorous rubbing with unsuitable materials.
- Frequent use of car washes.
- Washing the vehicle in direct sunlight.

! Never use paint cleaner, buffing or polishing products, or gloss preserver, e.g. wax. These products are only suitable for high-gloss surfaces. Their use on vehicles with matt finish leads to considerable surface damage (shiny, spotted areas).

Always have paintwork repairs carried out at a qualified specialist workshop.

! Do not use wash programs with a hot wax treatment under any circumstances.

Observe these notes if your vehicle has a clear matt finish. This will help you to avoid damage to the paintwork due to incorrect treatment.

These notes also apply to light-alloy wheels with a clear matt finish.

- i** The vehicle should preferably be washed by hand using a soft sponge, car shampoo and plenty of water.
- i** Use only insect remover and car shampoo from the range of recommended and approved Mercedes-Benz care products.

Cleaning vehicle parts

Cleaning the wheels

! Do not use acidic wheel cleaning products to remove brake dust. This could damage wheel bolts and brake components.

! Do not park up the vehicle for an extended period straight after cleaning it, particularly after having cleaned the wheels with wheel cleaner. Wheel cleaners could cause increased corrosion of the brake discs and brake pads/linings. For this reason, you should drive for a few minutes after cleaning. Braking heats the brake discs and the brake pads/linings, thus drying them. The vehicle can then be parked up.

Cleaning the windows

WARNING

If the windscreen wipers are set in motion when cleaning the windscreen or wiper blades, you could become trapped. There is a danger of injury.

Always switch off the windscreen wipers and the ignition before cleaning the windscreen or wiper blades.

! Only fold the windscreen wipers away from the windscreen when vertical. Otherwise, you will damage the bonnet.

! Do not use dry cloths, abrasive products, solvents or cleaning agents containing solvents to clean the inside of the windows. Do not touch the insides of the windows with hard objects, e.g. an ice scraper or ring. There is otherwise a risk of damaging the windows.

! Clean the water drainage channels of the windscreen and the rear window at regular intervals. Deposits such as leaves, petals and pollen may under certain circumstances prevent water from draining away. This can lead to corrosion damage and damage to electronic components.

► Clean the inside and outside of the windows with a damp cloth and a cleaning agent that is recommended and approved by Mercedes-Benz.

Cleaning the wiper blades

WARNING

If the windscreen wipers are set in motion when cleaning the windscreen or wiper blades, you could become trapped. There is a danger of injury.

Always switch off the windscreen wipers and the ignition before cleaning the windscreen or wiper blades.

- !** Do not pull on the wiper blade. Otherwise, the wiper blade could be damaged.
- !** Do not clean wiper blades too often and do not rub them too hard. Otherwise, the graphite coating could be damaged. This could cause wiper noise.
- !** Hold the wiper arm securely when folding back. The windscreen could be damaged if the wiper arm hits against it suddenly.
- ▶ Fold the wiper arms away from the windscreen.
- ▶ Clean the wiper blades carefully using a damp cloth.
- ▶ Fold the windscreen wipers back again before switching on the ignition.

Cleaning the exterior lighting

- !** Only use cleaning agents or cleaning cloths that are suitable for plastic lenses. Unsuitable cleaning agents or cleaning cloths could scratch or damage the plastic lenses of the exterior lighting.
- ▶ Clean the plastic lenses of the exterior lighting using a wet sponge and a mild cleaning agent, e.g. Mercedes-Benz car shampoo or cleaning cloths.

Mirror turn signal

- !** Only use cleaning agents or cleaning cloths that are suitable for plastic lenses. Unsuitable cleaning agents or cleaning cloths could scratch or damage the plastic lenses of the mirror turn signals.

- ▶ Clean the plastic lenses of the mirror turn signals in the exterior mirror housing using a wet sponge and mild cleaning agent, e.g. Mercedes-Benz car shampoo or cleaning cloths.

Cleaning the sensors

- !** If you clean the sensors with a high-pressure cleaner, make sure that you keep a distance of at least 30 cm between the vehicle and the high-pressure cleaner nozzle. Information about the correct distance is available from the equipment manufacturer.

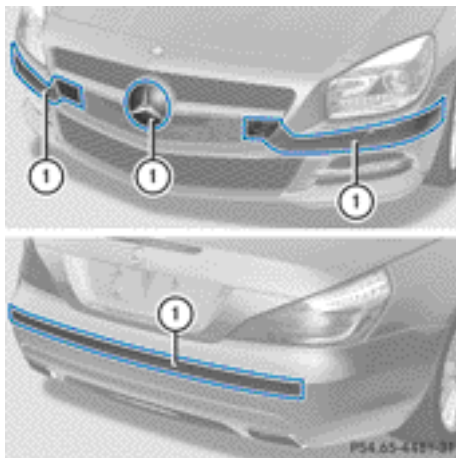

- ▶ Clean sensors ① of the driving systems with water, car shampoo and a soft cloth.

Cleaning the reversing camera

- !** Do not clean the camera lens and the area around the reversing camera with a high-pressure cleaner.



- ▶ Use clear water and a soft cloth to clean camera lens ①.

Cleaning the exhaust pipe

- ❗ Do not clean the exhaust pipe with acidic cleaning agents, such as sanitary or wheel cleaners.
- ▶ Clean the exhaust pipe with a chrome care product tested and approved by Mercedes-Benz.

Impurities combined with the effects of road grit and corrosive environmental factors may cause flash rust to form on the surface. You can restore the original shine of the exhaust pipe by cleaning it regularly, especially in winter and after washing.

Interior care

Cleaning the display

- ❗ For cleaning, do not use any of the following:
 - alcohol-based thinner or petrol
 - abrasive cleaning agents
 - commercially-available household cleaning agents

These may damage the display surface. Do not put pressure on the display surface when cleaning. This could lead to irreparable damage to the display.

- ▶ Before cleaning the display, make sure that it is switched off and has cooled down.
- ▶ Clean the display surface using a commercially available microfibre cloth and TFT/LCD display cleaner.
- ▶ Dry the display surface using a dry microfibre cloth.

Cleaning the plastic trim

⚠ WARNING

Care products and cleaning agents containing solvents can cause surfaces in the cockpit to become porous. This could result in plastic parts breaking away when the airbags are deployed. There is a danger of injury.

Do not use care products and cleaning agents containing solvents to clean the cockpit.

- ❗ Do not affix the following to plastic surfaces:
 - stickers
 - films
 - scented oil bottles or similar items
 You could otherwise damage the plastic.
- ❗ Do not allow cosmetics, insect repellent or sunscreen to come in contact with the plastic trim. This maintains the high-quality look of the surfaces.
- ▶ Wipe the plastic trim with a damp, lint-free cloth, e.g. a microfibre cloth.
- ▶ **Heavy soiling:** use car care and cleaning products recommended and approved by Mercedes-Benz.
The surface may change colour temporarily. Wait until the surface is dry again.

Cleaning the steering wheel and gear or selector lever

- ▶ Thoroughly wipe with a damp cloth or use leather care agents that have been recommended and approved by Mercedes-Benz.

Cleaning wooden trim and trim elements

- ❗ Do not use solvent-based cleaning agents such as tar remover, wheel cleaners, polishes or waxes. There is otherwise a risk of damaging the surface.
- ▶ Wipe the wooden trim and trim elements with a damp, lint-free cloth, e.g. a microfibre cloth.
- ▶ **Heavy soiling:** use car care and cleaning products recommended and approved by Mercedes-Benz.

Cleaning the seat covers

General notes

- ❗ Do not use microfibre cloths to clean genuine leather, artificial leather or Alcantara® covers. If used often, these can damage the cover.
- i Note that regular care is essential to make sure that the appearance and comfort of the covers are retained over time.

Genuine leather seat covers

- ❗ To retain the natural appearance of the leather, observe the following cleaning instructions:
 - Clean genuine leather covers carefully with a damp cloth and then wipe the covers down with a dry cloth.
 - Make sure that the leather does not become soaked. It may otherwise become rough and cracked.
 - Only use leather care agents that have been tested and approved by Mercedes-Benz. You can obtain these from a qualified specialist workshop.

Leather is a natural product. It has natural surface properties, e.g.:

- unevenness in structure
- marks caused by growth and injury
- subtle colour differences

These are characteristics of leather and not material faults.

Seat covers from other materials

- ❗ Observe the following when cleaning:
 - Clean artificial leather covers with a cloth moistened with a solution containing 1% detergent (e.g. washing-up liquid).
 - Clean cloth covers with a microfibre cloth moistened with a solution containing 1% detergent (e.g. washing-up liquid). Rub carefully, and always wipe entire seat sections to avoid leaving visible lines. Leave the seat to dry afterwards. Cleaning results depend on the type of dirt and how long it has been there.
 - Clean Alcantara® covers with a damp cloth. Make sure that you wipe entire seat sections to avoid leaving visible lines.

Cleaning the seat belts

WARNING

Seat belts may be severely weakened if bleached or coloured. This may lead to the seat belts, for example, tearing or failing in an accident. There is an increased risk of injury, possibly even fatal.

Never bleach or colour seat belts.

- ❗ Do not clean the seat belts using chemical cleaning agents. Do not dry the seat belts at temperatures above 80 °C or in direct sunlight.
- ▶ Use clean, lukewarm water and soap solution.

Cleaning the roof lining and carpets

- ▶ **Roof lining:** if it is very dirty, use a soft brush or dry shampoo.
- ▶ **Carpets:** use the carpet and textile cleaning agents recommended and approved by Mercedes-Benz.

Useful information	544
Where will I find...?	544
Flat tyre	546
Battery (vehicle)	550
Jump-starting	553
Towing and tow-starting	555
Electrical fuses	558

Useful information

- i** This Owner's Manual describes all models, series and optional equipment for your vehicle that were available at the time of going to press. National variations are possible. Note that your vehicle may not be equipped with all of the functions described. This is also the case for systems and functions relevant to safety.
- i** Read the information on qualified specialist workshops: (▷ page 38).

Where will I find...?

Warning triangle

Removing the warning triangle

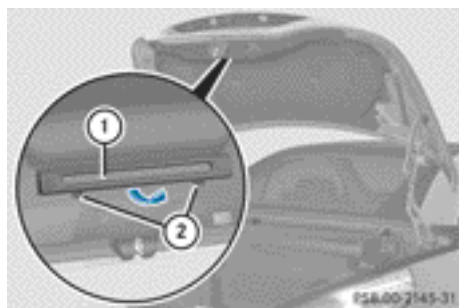

Warning triangle ① is located in a bracket on the inside of the boot lid.

- ▶ Open the boot lid.
- ▶ Press catch ② in the direction of the bracket and open the bracket in the direction of the arrow.
- ▶ Pull the clip of warning triangle ① in the centre of the bracket outward.
- ▶ Remove warning triangle ① from the bracket.

Setting up the warning triangle

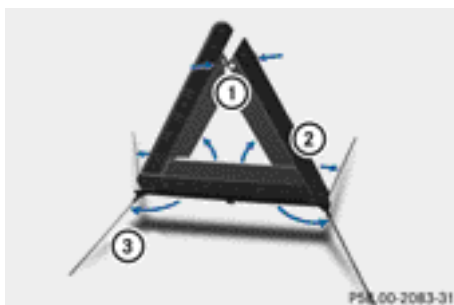

- ▶ Fold feet ③ down and out to the side.
- ▶ Pull side reflectors ② upwards to form a triangle and lock them at the top using upper press-stud ①.

First-aid kit



First-aid kit ① is located in the boot under the boot floor.

- ▶ Open the boot lid.
 - ▶ Open the boot separator (▷ page 105).
 - ▶ Lift the boot floor upwards (▷ page 516).
 - ▶ Remove first-aid kit ①.
- i** Check the expiry date on the first-aid kit at least once a year. Replace the contents if necessary, and replace any missing items.

Fire extinguisher

WARNING

When you brake heavily or change direction suddenly, the fire extinguisher can be thrown around the vehicle interior if the roller box is left open. There is a risk of accident and injury to you or the passenger. Keep the shutter of the roller box closed whilst the vehicle is in motion.

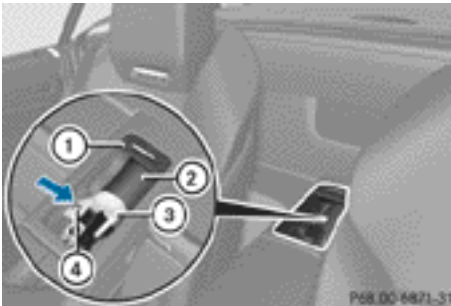

- ① Cover
- ② Fire extinguisher
- ③ Bracket
- ④ Locking button

Fire extinguisher ② is in the roller box behind the centre console, between the seats.

- ▶ **To remove the fire extinguisher:** open cover ①.
- ▶ Slide locking button ④ in the direction of the arrow.
- ▶ Lift and swing out bracket ③ from the side on which locking button ④ is located.
- ▶ Take fire extinguisher ② out of the roller box.
- ▶ **To install the fire extinguisher:** insert fire extinguisher ② in the roller box.
- ▶ Insert bracket ③ into the roller box on the side opposite locking button ④.
- ▶ Then, insert bracket ③ completely.
- ▶ Slide locking button ④ in the opposite direction to the arrow.

- ▶ Check whether bracket ③ is properly engaged.
- ▶ Close cover ①.
- ❗ Have fire extinguisher ② refilled after each use and checked every one to two years. It may otherwise fail in an emergency. Observe the legal requirements for each individual country.

Vehicle tool kit

General notes

The towing eye is located in the boot in a bracket below the boot lid lock. If the vehicle is equipped with a TIREFIT kit, it is located in the stowage compartment under the floor of the boot.

Vehicles with a TIREFIT kit

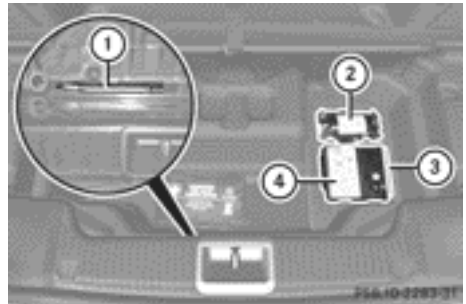

- ① Towing eye
- ② Tyre sealant filler bottle
- ③ Fuse allocation chart
- ④ Tyre inflation compressor
- ▶ Open the boot lid.
- ▶ Open the boot separator (▷ page 105).
- ▶ Lift the boot floor upwards (▷ page 516).

Tyre-change tool kit

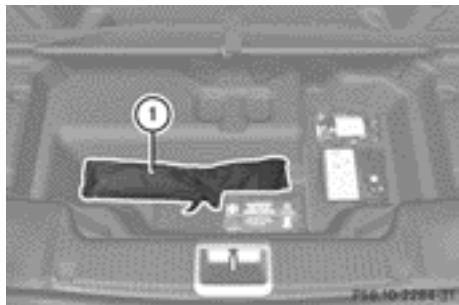

① A bag containing the tyre-changing tools

- ▶ Open the boot lid.
- ▶ Open the boot separator (▷ page 105).
- ▶ Lift the boot floor upwards (▷ page 516).

❗ Depending on the vehicle equipment, not all vehicles will have the tools that are required for changing a wheel, such as a jack. Tools approved for your vehicle are available at a qualified specialist workshop.

Bag with the tyre-changing tools ① contains:

- Jack
- Wheel wrench
- Centring pin
- Wheel chock
- Gloves

Flat tyre

Preparing the vehicle

Information on changing/fitting a wheel (▷ page 570).

Vehicle preparation is not necessary on vehicles with MOExtended tyres.

Your vehicle may be equipped with:

- MOExtended tyres (tyres with run-flat characteristics) (▷ page 546)
- a TIREFIT kit (▷ page 547)
- an emergency spare wheel (only for certain countries) (▷ page 579)

- ▶ Stop the vehicle as far away as possible from traffic on solid, non-slippery and level ground.
- ▶ Switch on the hazard warning lamps.
- ▶ Secure the vehicle against rolling away (▷ page 172).
- ▶ Bring the front wheels into the straight-ahead position.
- ▶ Switch off the engine.
- ▶ **Vehicles without KEYLESS-GO:** remove the key from the ignition lock.
- ▶ **Vehicles with KEYLESS-GO:** open the driver's door. The on-board electronics have status **0**, which is the same as the key having been removed.
- ▶ **Vehicles with KEYLESS-GO:** remove the Start/Stop button from the ignition lock (▷ page 153).
- ▶ All occupants must get out of the vehicle. Make sure that they are not endangered as they do so.
- ▶ Make sure that no one is near the danger area while a wheel is being changed. Anyone who is not directly assisting in the wheel change should, for example, stand behind the barrier.
- ▶ Get out of the vehicle. Pay attention to traffic conditions when doing so.
- ▶ Close the driver's door.
- ▶ Place the warning triangle a suitable distance away (▷ page 544). Observe legal requirements.

MOExtended tyres (tyres with run-flat characteristics)

⚠ WARNING

When driving in emergency mode, the driving characteristics deteriorate, e.g. when cornering, accelerating quickly and when braking. There is a risk of accident.

Do not exceed the stated maximum speed. Avoid abrupt steering and driving manoeuvres.

vres, and driving over obstacles (kerbs, pot-holes, off-road). This applies in particular to a laden vehicle.

Stop driving in emergency mode if:

- you hear banging noises.
- the vehicle starts to shake.
- you see smoke and smell rubber.
- ESP® is intervening constantly.
- there are tears in the sidewalls of the tyre.

After driving in emergency mode, have the wheel rims checked at a qualified specialist workshop with regard to their further use. The faulty tyre must be replaced.

With MOExtended tyres (tyres with run-flat characteristics), you can continue to drive your vehicle even if there is a total loss of pressure in one or more tyres.

MOExtended tyres may only be used in conjunction with an active tyre pressure loss warning system or with an active tyre pressure monitor.

The maximum driving distance is approximately 80 km when the vehicle is partially laden, and approximately 30 km when the vehicle is fully laden.

In addition to the vehicle load, the driving distance possible depends upon:

- speed
- road condition
- outside temperature

The driving distance possible in run-flat mode may be reduced by extreme driving conditions/manoeuvres, or it can be increased through a moderate style of driving.

The maximum permissible distance which can be driven in run-flat mode is counted from the moment the tyre pressure loss warning appears in the multifunction display.

You must not exceed a maximum speed of 80 km/h.

- i** When replacing one or all tyres, make sure that you only use tyres marked

"MOExtended". Make sure that you only use the size of tyre specified for the vehicle.

- i** Vehicles with MOExtended tyres are not equipped with a TIREFIT kit at the factory. It is therefore recommended that you additionally equip your vehicle with a TIREFIT kit if you fit tyres that do not feature run-flat characteristics, e.g. winter tyres. A TIREFIT kit is available, for example, from a qualified specialist workshop.

TIREFIT kit

Using the TIREFIT kit

TIREFIT is a tyre sealant.

You can use TIREFIT to seal punctures of up to 4 mm, particularly those in the tyre tread. You can use TIREFIT at outside temperatures down to -20 °C.

WARNING

In the following situations, the tyre sealant is unable to provide sufficient breakdown assistance, as it is unable to seal the tyre properly:

- there are cuts or punctures in the tyre larger than those mentioned above.
- the wheel rim is damaged.
- you have driven at very low tyre pressures or on a flat tyre.

There is a risk of accident.

Do not drive any further. Contact a qualified specialist workshop.

WARNING

The tyre sealant is harmful and causes irritation. It must not come into contact with your skin, eyes or clothing or be swallowed. Do not inhale TIREFIT fumes. Keep tyre sealant away from children. There is a risk of injury.

If you come into contact with the tyre sealant, observe the following:

- Rinse off the tyre sealant from your skin immediately with water.
- If the tyre sealant comes into contact with your eyes, immediately rinse them thoroughly with clean water.
- If tyre sealant is swallowed, immediately rinse your mouth out thoroughly and drink plenty of water. Do not induce vomiting, and seek medical attention immediately.
- Immediately change out of clothing which has come into contact with tyre sealant.
- If an allergic reaction occurs, seek medical attention immediately.

! Do not operate the tyre inflation compressor for longer than eight minutes at a time without a break. It may otherwise overheat.

The tyre inflation compressor can be operated again once it has cooled down.

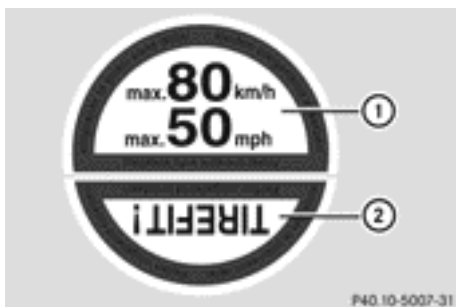

TIREFIT sticker, 2-part

- ▶ Do not remove any foreign objects which have penetrated the tyre, e.g. screws or nails.
- ▶ Remove the tyre sealant bottle, the accompanying TIREFIT sticker and the tyre inflation compressor from the stowage space under the boot floor (▷ page 545).
- ▶ Affix part ① of the TIREFIT sticker within the driver's field of vision.
- ▶ Affix part ② of the TIREFIT sticker near the valve on the wheel with the defective tyre.

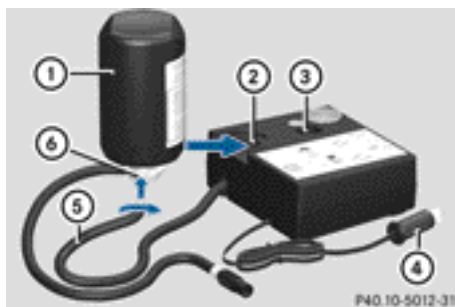

- ▶ Pull plug ④ with the cable and hose ⑤ out of the housing.
- ▶ Screw hose ⑤ onto flange ⑥ of tyre sealant bottle ①.
- ▶ Place tyre sealant bottle ① head downwards into recess ② of the tyre inflation compressor.

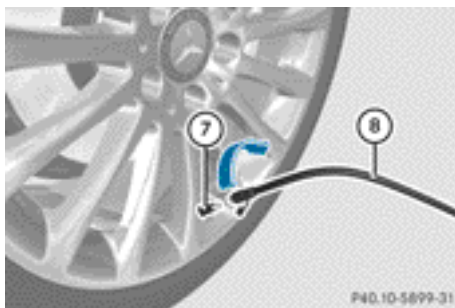

- ▶ Remove the cap from valve ⑦ on the faulty tyre.
- ▶ Screw filler hose ⑧ onto valve.
- ▶ Insert plug ④ into the socket of the cigarette lighter or into a 12 V power socket in your vehicle. Observe the notes on the cigarette lighter (▷ page 518). Observe the notes on sockets (▷ page 518).
- ▶ Turn the key to position 1 in the ignition lock (▷ page 153).
- ▶ Press on/off switch ③ on the tyre inflation compressor to I. The tyre inflation compressor is switched on. The tyre is inflated.

- i** First, tyre sealant is pumped into the tyre. The pressure can briefly rise to approximately 500 kPa (5.0 bar/73 psi).

Do not switch off the tyre inflation compressor during this phase.

- ▶ Let the tyre inflation compressor run for five minutes. The tyre should then have attained a pressure of at least 180 kPa (1.8 bar/26 psi).

If a tyre pressure of 180 kPa (1.8 bar/26 psi) has been attained after five minutes: (▷ page 549).

If a tyre pressure of 180 kPa (1.8 bar/26 psi) has not been attained after five minutes: (▷ page 549).

- i** If the tyre sealant leaks out, allow it to dry. It can then be removed like a layer of film. If you get tyre sealant on your clothing, have it cleaned as soon as possible with perchloroethylene.

Tyre pressure not reached

If a tyre pressure of 180 kPa (1.8 bar/26 psi) has not been attained after five minutes:

- ▶ Switch off the tyre inflation compressor.
- ▶ Unscrew the filler hose from the valve of the faulty tyre.
- ▶ Very slowly drive forwards or reverse approximately 10 m.
- ▶ Pump up the tyre again.
After a maximum of five minutes the tyre pressure must be at least 180 kPa (1.8 bar/26 psi).

WARNING

If the required tyre pressure is not reached after the specified time, the tyre is too badly damaged. The tyre sealant cannot repair the tyre in this instance. Damaged tyres and a tyre pressure that is too low can significantly impair the vehicle's braking and driving characteristics. There is a risk of accident.

Do not continue driving. Contact a qualified specialist workshop.

Tyre pressure reached

WARNING

A tyre temporarily sealed with tyre sealant impairs the driving characteristics and is not suitable for higher speeds. There is a risk of accident.

You should therefore adapt your driving style accordingly and drive carefully. Do not exceed the specified maximum speed with a tyre that has been repaired using tyre sealant.

- !** After use, excess tyre sealant may run out of the filler hose. This could cause stains. Therefore, place the filler hose in the plastic bag which contained the TIREFIT kit.

Environmental note

Have the used tyre sealant bottle disposed of professionally, e.g. at a qualified specialist workshop.

If a pressure of 180 kPa (1.8 bar/26 psi) has been attained after a maximum of ten minutes:

- ▶ Switch off the tyre inflation compressor.
- ▶ Unscrew the filler hose from the valve of the faulty tyre.
- ▶ Stow the tyre sealant bottle, the tyre inflation compressor and the warning triangle.
- ▶ **Pull away immediately.**
The maximum speed for a tyre sealed with tyre sealant is 80 km/h. The upper part of the TIREFIT sticker must be affixed to the instrument cluster in the driver's field of vision.
- ▶ Stop after driving for approximately ten minutes and check the tyre pressure with the tyre inflation compressor.
The tyre pressure must now be at least 130 kPa (1.3 bar/19 psi).

WARNING

If the required tyre pressure is not reached after driving for a short period, the tyre is too badly damaged. The tyre sealant cannot repair the tyre in this instance. Damaged tyres and a tyre pressure that is too low can significantly impair the vehicle's braking and driving characteristics. There is a risk of accident. Do not continue driving. Contact a qualified specialist workshop.

- ▶ Correct the tyre pressure if it is still at least 130 kPa (1.3 bar/ 19 psi) (see the fuel filler flap for values).
- ▶ **To increase the tyre pressure:** switch on the tyre inflation compressor.

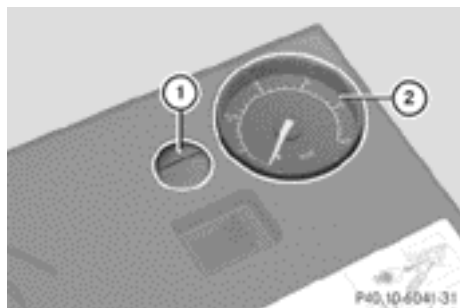

- ▶ **To reduce the tyre pressure:** depress pressure release button ① next to pressure gauge ②.
- ▶ When the tyre pressure is correct, unscrew the filler hose from the valve of the repaired tyre.
- ▶ Screw the valve cap onto the valve of the repaired tyre.
- ▶ Pull the tyre sealant bottle out of the tyre inflation compressor.
The filler hose stays on the tyre sealant bottle.
- ▶ Stow the tyre sealant bottle, the tyre inflation compressor and the warning triangle.
- ▶ Drive to the nearest qualified specialist workshop and have the tyre changed there.

- ▶ Have the tyre sealant bottle replaced as soon as possible at a qualified specialist workshop.
- ▶ Have the tyre sealant bottle replaced every four years at a qualified specialist workshop.

i In your vehicle, you will find a sticker with the Mercedes-Benz Service24h telephone number, e.g. on the B-pillar on the driver's side.

Battery (vehicle)

Important safety notes

Work on the battery, e.g. removing or installing, requires specialist knowledge and the use of special tools. Therefore, always have work on the battery carried out at a qualified specialist workshop.

WARNING

Work carried out incorrectly on the battery can, for example, lead to a short circuit and damage your vehicle's electronic system. This can disrupt driving safety systems such as ABS (anti-lock braking system) or ESP® (Electronic Stability Program).

- If ABS malfunctions, the wheels can lock during braking. This limits the steerability of the vehicle when braking and the braking distance may increase. There is a risk of accident.
- If ESP® malfunctions, the vehicle will not be stabilised if it starts to skid or a wheel starts to spin. There is a risk of accident.

You should therefore have all work involving the battery carried out at a qualified specialist workshop.

WARNING

Comply with safety precautions and take protective measures when handling batteries.



Risk of explosion



Fire, naked flames and smoking are prohibited when handling the battery. Avoid creating sparks.



Battery acid is caustic. Avoid contact with the skin, eyes or clothing.

Wear suitable protective clothing, in particular gloves, an apron and a face mask.

Immediately rinse acid splashes off with clean water. Consult a doctor if necessary.

Wear eye protection.



Keep children away.



Observe this Owner's Manual.



WARNING

For safety reasons, Mercedes-Benz recommends that you only use batteries which have been tested and approved for your vehicle by Mercedes-Benz. These batteries provide increased impact protection to prevent vehicle occupants from suffering acid burns should the battery be damaged in the event of an accident.

To prevent acid burns, observe the following safety notes when handling batteries:

- do not lean over the battery.
- do not place any metal objects on a battery. Otherwise, you could cause a short circuit and the battery's gas mixture could ignite.

- make sure that you do not create an electrostatic charge, e.g. by wearing synthetic clothing or as a result of friction on fabrics. Therefore, you should not pull or slide the battery over carpets or other synthetic materials.
- never touch the battery first. To discharge a possible electrostatic charge, step out of the vehicle first and touch the bodywork.
- do not wipe the battery using a cloth. The battery may explode as a result of electrostatic charge or due to flying sparks.

Environmental note



Batteries contain pollutants. It is illegal to dispose of them with the household rubbish. They must be collected separately and disposed of in an environmentally responsible recycling system.



Dispose of batteries in an environmentally responsible manner. Take discharged batteries to a qualified specialist workshop or to a collection point for used batteries.

- ❗ Have the battery checked regularly at a qualified specialist workshop. Observe the service intervals in the Service Booklet or contact a qualified specialist workshop for more information.
- ❗ You should have all work involving the battery carried out at a qualified specialist workshop. In the exceptional case that it is necessary for you to disconnect the battery yourself, make sure that:
 - you switch off the engine and remove the key. On vehicles with KEYLESS-GO, ensure that the ignition is switched off. Check that all the indicator lamps in the instrument cluster are off. Otherwise,

electronic components, such as the alternator, may be damaged.

- you first remove the negative terminal clamp and then the positive terminal clamp. Never swap the terminal clamps. Otherwise, the vehicle's electronic system may be damaged.
- the transmission is locked in position **P** after disconnecting the battery. The vehicle is secured against rolling away. You can then no longer move the vehicle.

The battery and the cover of the positive terminal clamp must be fitted securely during operation.

In order for the battery to achieve the maximum possible service life, it must always be sufficiently charged.

The vehicle battery, like other batteries, can discharge over time if you do not use the vehicle. In such cases, have the battery disconnected at a qualified specialist workshop. You can also charge the battery with a charger recommended by Mercedes-Benz. For more information, please contact a qualified specialist workshop.

Have the battery charge checked more frequently if you use the vehicle mainly for short trips or if you leave it standing idle for a lengthy period. Consult a qualified specialist workshop if you wish to leave your vehicle parked up for a long period of time.

- ❗ When you park the vehicle, remove the key if you do not require any electrical consumers. The vehicle will then use very little energy, thus conserving battery power.

Charging the battery

WARNING

Only charge the battery in a well-ventilated area. As the battery is being charged, gases can escape and generate minor explosions. This could injure you and other persons or cause damage to the paintwork or acid corrosion on the vehicle.

You can obtain information on battery chargers which allow the battery to be charged while still installed from a qualified specialist workshop.

WARNING

There is a risk of acid burns during the charging process due to the gases which escape from the battery. Do not lean over the battery during the charging process.

WARNING

Battery acid is caustic. Avoid contact with the skin, eyes or clothing.

- ❗ Only charge the installed battery with a battery charger which has been tested and approved by Mercedes-Benz. These battery chargers allow the battery to be charged while still installed in the vehicle.
- ❗ Only use battery chargers with a maximum charging voltage of 14.8 V.
- ❗ Only charge the battery using the jump-start connection point.

The jump-starting connection point is in the engine compartment.

Read the battery charger's operating instructions before charging the battery.

- ▶ Open the bonnet (▷ page 531).
- ▶ Connect the battery charger to the positive terminal and earth point in the same order as when connecting the donor battery in the jump-starting procedure (▷ page 553).

Jump-starting

WARNING

There is a risk of acid burns when jump-starting a vehicle due to the gases which escape from the battery. Do not lean over the battery while the engine is being jump-started.

WARNING

Gases escaping from the battery during jump-starting may cause minor explosions. Avoid creating sparks. Keep naked flames away from the battery, and do not smoke.

Comply with the important safety precautions when handling batteries. You will find these under "Battery (vehicle) - important safety notes" in the index.

WARNING

Non-combusted fuel can collect in the exhaust system and ignite. There is a risk of fire. Avoid repeated and lengthy starting attempts.

! Avoid repeated and lengthy starting attempts. Otherwise, the catalytic converter could be damaged by the non-combusted fuel.

Do not use a rapid charging device to start the vehicle. If your vehicle's battery is discharged, the engine can be jump-started from another vehicle or from a second battery using jump leads. Observe the following points:

- The battery is not accessible in all vehicles. If the other vehicle's battery is not accessible, jump-start the vehicle using a second battery or a jump-starting device.
- You may only jump-start the vehicle when the engine and exhaust system are cold.
- Do not start the engine if the battery is frozen. Let the battery thaw first.
- Jump-starting may only be performed from batteries with a nominal voltage of 12 V.
- Only use jump leads that have a sufficient cross-section and insulated terminal clamps.
- If the battery is fully discharged, leave the battery that is being used to jump-start connected for a few minutes before attempting to start. This charges the empty battery a little.
- Make sure that the two vehicles do not touch.

Make sure that:

- The jump leads are not damaged.
- Non-insulated parts of the terminal clamps do not come into contact with other metal parts while the jump leads are connected to the battery.
- The jump leads cannot come into contact with parts such as the V-belt pulley or the fan. These parts move when the engine is started and while it is running.
- ▶ Secure the vehicle by applying the electric parking brake.
- ▶ Shift the transmission to position **P**.
- ▶ Turn the key to position **0** in the ignition lock and remove it (▷ page 153). On vehicles with KEYLESS-GO, make sure the ignition is switched off (▷ page 153). All indicator lamps in the instrument cluster must be off.
- ▶ Switch off all electrical consumers (e.g. radio, blower, etc.).
- ▶ Open the bonnet (▷ page 531).

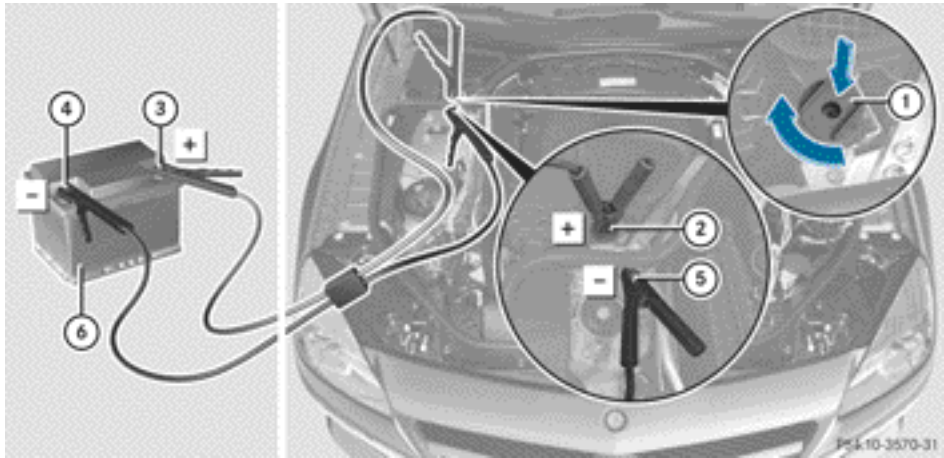

Position number ⑥ identifies the charged battery of the other vehicle or an equivalent jump-starting device.

- ▶ Press cover ① of positive terminal ② down (in the direction of the arrow) and turn it clockwise. Cover ① is held down in the lowered position, which exposes positive terminal ②.
 - ▶ Connect positive terminal ② on your vehicle to positive terminal ③ of donor battery ⑥ using the jump lead, always begin with positive terminal ② on your own vehicle first.
 - ▶ Start the engine of the donor vehicle and run it at idling speed.
 - ▶ Connect negative terminal ④ of donor battery ⑥ to earth point ⑤ of your vehicle using the jump lead, connecting the jump lead to donor battery ⑥ first.
 - ▶ Start the engine.
 - ▶ Before disconnecting the jump leads, let the engines run for several minutes.
 - ▶ First, remove the jump leads from earth point ⑤ and negative terminal ④, then from positive clamp ② and positive terminal ③. Begin each time at the contacts on your own vehicle first.
 - ▶ After removing the jump leads, press down cover ① of positive terminal ② and turn it anti-clockwise. Cover ① returns to its original position. Positive terminal ② is covered up and thus insulated again.
 - ▶ Have the battery checked at a qualified specialist workshop.
- i** Jump-starting is not considered to be a normal operating condition.
- i** Jump-starting cables and further information regarding jump starting can be obtained at any qualified specialist workshop.

Towing and tow-starting

Important safety notes

WARNING

If you tow the vehicle, you must use a rigid towing bar if:

- the engine is not running.
- there is a brake system malfunction.
- there is a malfunction in the power supply or the vehicle's electrical system.

The power assistance for the steering and the brake force booster do not work when the engine is not running. You will need more force to steer and brake, you may have to depress the brake pedal with maximum force.

Before towing away, make sure that the steering can be moved and is not locked.

If you tow or tow-start another vehicle, its weight must not exceed the maximum permissible gross vehicle weight of your vehicle.

WARNING

The vehicle is braked when the HOLD function or DISTRONIC PLUS is activated. Therefore, deactivate HOLD and DISTRONIC PLUS if the vehicle is to be towed.

 Only secure the tow rope or towing bar to the towing eyes. The vehicle may otherwise be damaged.

 Observe the following points when towing with a tow rope:

- secure the tow rope on the same side on both vehicles.
- the tow rope must not be longer than is legally permitted. It should be marked in the middle, e.g. with a white cloth (30 x 30 cm) so that other road users are aware that a vehicle is being towed.
- the tow rope may only be attached to the towing eyes.
- observe the brake lamps of the towing vehicle while driving. Always maintain a

distance so that the tow rope does not sag.

- do not use steel cables or chains to tow your vehicle. The vehicle could be damaged.

 Do not use the towing eye for recovery, this could damage the vehicle. If in doubt, recover the vehicle with a crane.

 When towing, pull away slowly and smoothly. If the tractive power is too high, the vehicles could be damaged.

 To tow vehicles with KEYLESS-GO, use the key instead of the Start/Stop button. The automatic transmission may otherwise switch to position **P** when you open the driver's or front-passenger door which could damage the transmission.

 Make sure that the electric parking brake is released. If the electric parking brake is faulty, visit a qualified specialist workshop.

 You may tow the vehicle for a maximum of 50km. A towing speed of 50 km/h must not be exceeded.

For towing distances over 50 km, the entire vehicle must be lifted up and transported.

 If you tow or tow-start another vehicle, its weight must not exceed the maximum permissible gross vehicle weight of your vehicle.

Information on your vehicle's gross vehicle weight rating can be found on the vehicle identification plate (▷ page 586).

Observe the legal requirements for the relevant countries when towing.

It is better to have the vehicle transported than to have it towed.

The automatic transmission must be in position **N** when the vehicle is being towed.

The battery must be connected and charged. Otherwise, you:

- cannot turn the key in the ignition lock to position **2**
- cannot shift the automatic transmission to position **N**

i Deactivate the automatic locking feature (▷ page 236). You could otherwise be locked out when pushing or towing the vehicle.

Deactivate tow-away protection before the vehicle is towed (▷ page 81).

Fitting/removing the towing eye

Fitting the towing eye

WARNING

The exhaust tail pipe may be hot. You could burn yourself if you touch the tail pipe. Be particularly careful when removing the rear cover.

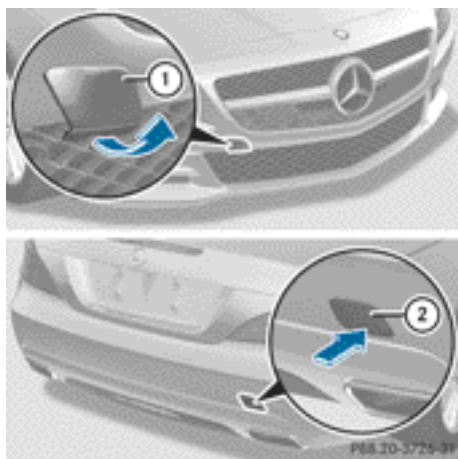

Example: covers for towing eye mountings

- ① Front cover
- ② Back cover

The mountings for the screw-in towing eyes are located in the bumpers. They are at the front and at the rear, under the covers.

- ▶ Remove the towing eye from the vehicle tool kit (▷ page 545).
- ▶ **Front bumper:** insert a finger into the recess on the bottom edge of cover ①.
- ▶ Pull cover ① out of the bumper towards you in the direction of the arrow. Cover ① is attached to the opening with a strap.
- ▶ **Rear bumper:** press the mark on cover ② inwards in the direction of the arrow.
- ▶ Take cover ② off the opening.
- ▶ Screw the towing eye in clockwise to the stop and tighten it.

Removing the towing eye

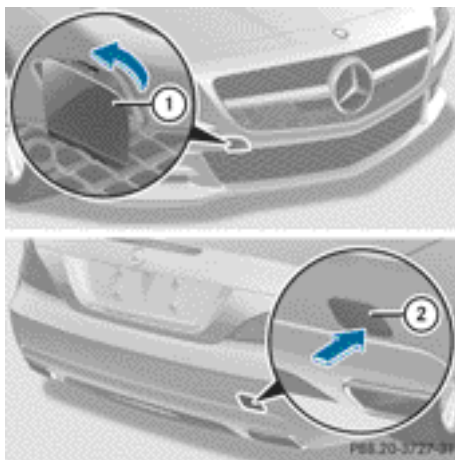

Example: covers for towing eye mountings

- ① Front cover
- ② Back cover

- ▶ Loosen the towing eye and unscrew it.
- ▶ **Front bumper:** position cover ① on the opening in the bumper, as shown.
- ▶ Twist cover ① into the opening in the direction of the arrow. Cover ① is now attached at the top edge of the opening.

- ▶ To close, press the lower section of cover ①.
- ▶ **Rear bumper:** position cover ② on bumper and press until it engages.
- ▶ Place the towing eye in the vehicle tool kit (▷ page 545).

Towing the vehicle with the rear axle raised

- !** The ignition must be switched off if you are towing the vehicle with the rear axle raised. Intervention by ESP® could otherwise damage the brake system.
- ▶ Switch on the hazard warning lamps (▷ page 130).
 - ▶ Turn the key in the ignition lock to position **0** and remove the key from the ignition lock.
 - ▶ When leaving the vehicle, take the key or the KEYLESS-GO key with you.

When towing your vehicle with the rear axle raised, it is important that you observe the safety instructions (▷ page 555).

Towing the vehicle with both axles on the ground

WARNING

The power assistance for the steering and the brake force booster do not work when the engine is not running. You will then need much more effort to brake and steer the vehicle. Adapt your style of driving accordingly.

The automatic transmission automatically shifts to position **P** when you open the driver's or front-passenger door or when you remove the key from the ignition lock.

In order to ensure that the automatic transmission stays in position **N** when towing the vehicle, you must observe the following points:

- ▶ Switch on the hazard warning lamps (▷ page 130).
- i** In order to signal a change of direction when towing the vehicle with the hazard warning lamps switched on, use the combination switch as usual. In this case, only the turn signals for the desired direction flash. When the combination switch is reset, the hazard warning lamps start flashing again.
- ▶ Make sure that the vehicle is stationary and that the key is in position **0** in the ignition lock.
- ▶ Turn the key to position **2** in the ignition lock.
On vehicles with KEYLESS-GO, use the key instead of the Start/Stop button (▷ page 153).
- ▶ Depress and hold the brake pedal.
- ▶ Shift the automatic transmission to position **N**.
- ▶ Release the brake pedal.
- ▶ Release the electric parking brake.
- ▶ Leave the key in position **2** in the ignition lock.

It is important that you observe the safety instructions when towing away your vehicle (▷ page 555).

Transporting the vehicle

- !** Only lash the vehicle down by the wheels or wheel rims, not by parts of the vehicle such as axle or steering components. Otherwise, the vehicle could be damaged.

The towing eye can be used to pull the vehicle onto a trailer or transporter for transporting purposes.

- ▶ Turn the key to position **2** in the ignition lock.
- ▶ Shift the automatic transmission to position **N**.

As soon as the vehicle is loaded:

- ▶ Prevent the vehicle from rolling away by applying the electric parking brake.
- ▶ Shift the automatic transmission to position **P**.
- ▶ Turn the key to position **0** in the ignition lock and remove it.
- ▶ Secure the vehicle.

Tow-starting (emergency engine starting)

- ❗ Vehicles with automatic transmission must not be tow-started. Otherwise, you could damage the automatic transmission.

You can find information on "Jump-starting" at (▷ page 553).

Electrical fuses

Important safety notes

WARNING

Only use fuses that have been approved for Mercedes-Benz vehicles and which have the correct fuse rating for the systems concerned. Do not attempt to repair or bridge faulty fuses. Using fuses which have not been approved or attempting to repair or bridge faulty fuses could cause the fuse to be overloaded and result in a fire. Have the cause traced and rectified at a qualified specialist workshop.

- ❗ Only use fuses that have been approved for Mercedes-Benz vehicles and which have the correct fuse rating for the system concerned. Otherwise, components or systems could be damaged.

The fuses in your vehicle serve to close down faulty circuits. If a fuse blows, all the components on the circuit and their functions stop operating.

Blown fuses must be replaced with fuses of the same rating, which you can recognise by the colour and fuse rating. The fuse ratings are listed in the fuse allocation chart.

If the newly inserted fuse also blows, have the cause traced and rectified at a qualified specialist workshop, e.g. a Mercedes-Benz Service Centre.

Before replacing a fuse

- ▶ Secure the vehicle against rolling away (▷ page 172).
- ▶ Switch off all electrical consumers.
- ▶ Turn the key to position **0** in the ignition lock and remove it (▷ page 153).

or

- ▶ On vehicles with KEYLESS-GO, make sure the ignition is switched off (▷ page 153).

All indicator lamps in the instrument cluster must be off.

The fuses are located in various fuse boxes:

- fuse box in the engine compartment on the right-hand side of the vehicle, when viewed in the direction of travel
- dashboard fuse box
- fuse box in the rear compartment on the right-hand side of the vehicle, when viewed in the direction of travel

The fuse allocation chart is located in the vehicle tool kit in the stowage compartment under the boot floor (▷ page 545).

Dashboard fuse box

- ❗ Do not use a pointed object such as a screwdriver to open the cover in the dashboard. You could damage the dashboard or the cover.

- ❗ Make sure that no moisture can enter the fuse box when the cover is open.
- ❗ When closing the cover, make sure that it is lying correctly on the fuse box. Moisture seeping in or dirt could otherwise impair the operation of the fuses.



- ▶ **To open:** pull cover ① outwards in the direction of the arrow and remove it.
- ▶ **To close:** clip in cover ① on the front of the dashboard.
- ▶ Fold cover ① inwards until it engages.

Fuse box in the engine compartment

- ❗ Make sure that no moisture can enter the fuse box when the cover is open.
- ❗ When closing the cover, make sure that it is lying correctly on the fuse box. Moisture seeping in or dirt could otherwise impair the operation of the fuses.
- ▶ Open the bonnet.

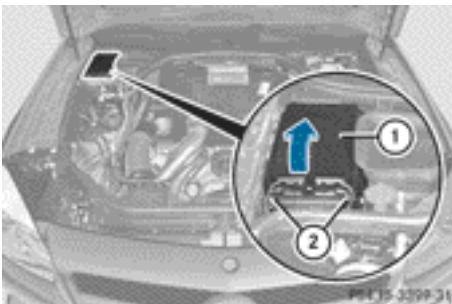

- ▶ Use a dry cloth to remove any existing moisture from the fuse box.
- ▶ **To open:** open clamps ②.
- ▶ Fold cover ① of the fuse box up in the direction of the arrow and remove it.

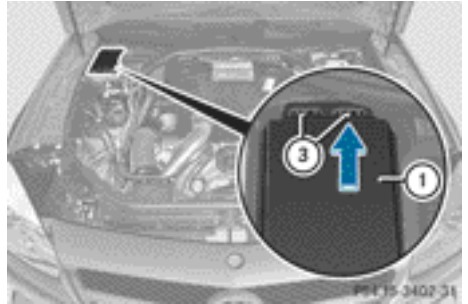

- ▶ **To close:** check whether the seal is seated correctly in cover ①.
- ▶ Insert both openings ③ at the rear of cover ① into the brackets on the fuse box. The brackets on the fuse box must be completely visible in the two openings ③ on the fuse box.
- ▶ Fold down cover ①.
- ▶ Hook clamps ② into the fuse box and close.
- ▶ Close the bonnet.

Fuse box in the rear

- ❗ Make sure that no moisture can enter the fuse box when the cover is open.
- ❗ When closing the cover, make sure that it is lying correctly on the fuse box. Moisture seeping in or dirt could otherwise impair the operation of the fuses.

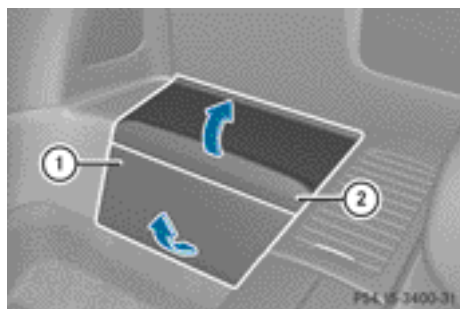

The fuse box in the rear is located on the right-hand side when viewed in the direction of travel.

- ▶ **To open:** open the seat belt guide on the right-hand seat and remove the seat belt (▷ page 115).
- ▶ Move the right-hand front seat as far forward as possible (▷ page 115).
- ▶ Insert your fingers at the bottom of front cover ① between the cover and floor covering.
- ▶ Remove front cover ① towards the front by pulling it in the direction of the arrow.
- ▶ Lift off top cover ② by pulling it in the direction of the arrow.

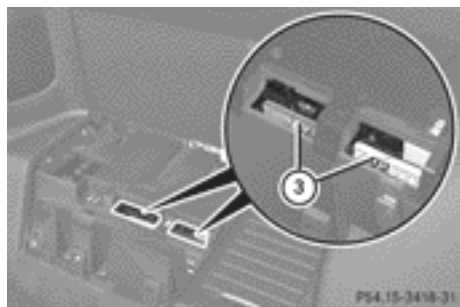

Fuses ③ are accessible through the two openings in the top of the fuse box.

- ▶ **To close:** insert the securing tags underneath top cover ② in the recesses at the top of the fuse box.
- ▶ Fold down top cover ② until it engages audibly.

- ▶ Insert the securing tags underneath top cover ① in the recesses at the front of the fuse box.
- ▶ Push front cover ① towards the rear until it engages audibly.
- ▶ Move the right-hand seat backwards (▷ page 115).
- ▶ Hook the seat belt into the seat belt guide on the right-hand seat (▷ page 115).

Useful information	562
Important safety notes	562
Operation	562
Winter operation	564
Tyre pressure	565
Changing a wheel	570
Wheel and tyre combinations	575
Emergency spare wheel	579

Useful information

- i** This Owner's Manual describes all models, series and optional equipment for your vehicle that were available at the time of going to press. National variations are possible. Note that your vehicle may not be equipped with all of the functions described. This is also the case for systems and functions relevant to safety.
- i** Read the information on qualified specialist workshops: (▷ page 38).

Important safety notes

WARNING

If wheels and tyres of the wrong size are used, the wheel brakes or suspension components may be damaged. There is a risk of accident. Always replace wheels and tyres with those that fulfil the specifications of the original part (designation, manufacturer, model).

WARNING

A flat tyre severely impairs the driving, steering and braking characteristics of the vehicle. There is a risk of accident.

Tyres without run-flat characteristics:

- do not drive with a flat tyre.
- immediately replace the flat tyre with your emergency spare wheel or spare wheel, or consult a qualified specialist workshop.

Tyres with run-flat characteristics:

- pay attention to the information and warning notices on MOExtended tyres (tyres with run-flat characteristics).

Accessories that are not approved for your vehicle by Mercedes-Benz or are not being used correctly can impair the operating safety.

Before purchasing and using non-approved accessories, visit a qualified specialist workshop and enquire about:

- suitability
- legal stipulations
- factory recommendations

Information on dimensions and types of wheels and tyres for your vehicle can be found (▷ page 575).

Information on air pressure for the tyres on your vehicle can be found:

- on the tyre pressure label on the fuel filler flap
- under "Tyre pressure"

Modification work on the brake system and wheels is not permitted. The use of wheel spacers or brake dust shields is not permitted. This invalidates the general operating permit for the vehicle.

- i** Further information on wheels and tyres can be obtained at any qualified specialist workshop.

Operation

Information on driving

Check the tyre pressures when the vehicle is heavily laden and, if necessary, adjust.

While driving, pay attention to vibrations, noises and unusual handling characteristics, e.g. pulling to one side. This may indicate that the wheels or tyres are damaged. If you suspect that a tyre is defective, reduce your speed immediately. Stop the vehicle as soon as possible to check the wheels and tyres for damage. Hidden tyre damage could also be causing the unusual handling characteristics. If you find no signs of damage, have the tyres and wheels checked at a qualified specialist workshop.

When parking your vehicle, make sure that the tyres do not get deformed by the kerb or other obstacles. If it is necessary to drive over kerbs, speed humps or similar elevations, try

to do so slowly and at an obtuse angle. Otherwise, the tyres, particularly the sidewalls, may be damaged.

Regular checking of wheels and tyres

WARNING

Damaged tyres can cause tyre inflation pressure loss. As a result, you could lose control of your vehicle. There is a risk of accident.

Check the tyres regularly for signs of damage and replace any damaged tyres immediately.

Regularly check the wheels and tyres of your vehicle for damage at least once a month, as well as after driving off-road or on rough roads. Damaged wheels can cause a loss of tyre pressure. Pay particular attention to damage such as:

- cuts in the tyres
- punctures
- tears in the tyres
- bulges on tyres
- deformation or severe corrosion on wheels

Regularly check the tyre tread depth and the condition of the tread across the whole width of all tyres (▷ page 563). If necessary, turn the front wheels to full lock in order to inspect the inner side of the tyre surface.

All wheels must have a valve cap to protect the valve against dirt and moisture. Do not fit anything onto the valve other than the standard valve cap or other valve caps approved by Mercedes-Benz for your vehicle. Do not fit any other valve caps or systems, e.g. tyre pressure monitoring systems.

Regularly check the pressure of all the tyres, particularly prior to long trips. Adjust the tyre pressure as necessary (▷ page 565).

Observe the notes on the emergency spare wheel (▷ page 579).

The service life of tyres depends on various factors, including the following:

- driving style
- tyre pressure
- tyre mileage

Tyre tread

WARNING

Insufficient tyre tread will reduce tyre traction. The tyre is no longer able to dissipate water. This means that on wet road surfaces, the risk of aquaplaning increases, in particular where speed is not adapted to suit the driving conditions. There is a risk of accident.

If the tyre pressure is too high or too low, tyres may exhibit different levels of wear at different locations on the tyre tread. Thus, you should regularly check the tread depth and the condition of the tread across the entire width of all tyres.

Minimum tyre tread depth for:

- summer tyres: 3 mm
- M+S tyres: 4 mm

For safety reasons, replace the tyres before the legally prescribed limit for the minimum tyre tread depth is reached..

Selecting, fitting and replacing tyres

- Only fit tyres and wheels of the same type and make.
- Only fit tyres of the correct size onto the wheels.
- Run in new tyres at moderate speeds for the first 100 km. They only reach their full performance after this distance.
- Do not drive with tyres which have too little tread depth. This otherwise significantly reduces the traction on wet roads (aquaplaning).
- Replace the tyres after six years at the latest, regardless of wear.

Observe the notes on the emergency spare wheel (▷ page 579).

MOExtended tyres (tyres with run-flat characteristics)

With MOExtended tyres (tyres with run-flat characteristics), you can continue to drive your vehicle even if there is a total loss of pressure in one or more tyres.

MOExtended tyres may only be used in conjunction with an active tyre pressure loss warning system or with an active tyre pressure monitor and on wheels specifically tested by Mercedes-Benz.

Notes on driving with MOExtended tyres with a flat tyre (▷ page 546).

- i** Vehicles with MOExtended tyres are not equipped with a TIREFIT kit at the factory. It is therefore recommended that you additionally equip your vehicle with a TIREFIT kit if you fit tyres that do not feature run-flat characteristics, e.g. winter tyres. A TIREFIT kit can be obtained from a qualified specialist workshop.

Winter operation

General notes

Have your vehicle winterproofed at a qualified specialist workshop at the onset of winter.

Observe the notes in the "Changing a wheel" section (▷ page 570).

Driving with summer tyres

At temperatures below +7 °C, summer tyres lose elasticity and therefore traction and braking power. Change the tyres on your vehicle to M+S tyres. Using summer tyres at very cold temperatures could cause tears to form, thereby damaging the tyres permanently. Mercedes-Benz cannot accept responsibility for this type of damage.

M+S tyres

WARNING

M+S tyres with a tyre tread depth of less than 4 mm are not suitable for use in winter as they do not provide sufficient traction. There is a risk of accident.

M+S tyres with a tread depth of less than 4 mm must be replaced.

At temperatures below +7 °C, use winter tyres or all-season tyres. Both types of tyre are identified by the M+S marking.

Only winter tyres bearing the  snowflake symbol in addition to the M+S marking provide the best possible grip in wintry road conditions.

Only these tyres will allow driving safety systems such as ABS and ESP® to function optimally in winter. These tyres have been developed specifically for driving in snow.

Use M+S tyres of the same make and tread on all wheels to maintain safe handling characteristics.

Always observe the maximum permissible speed specified for the M+S tyres you have fitted.

If you fit M+S tyres that have a lower maximum permissible speed than that of the vehicle, affix a corresponding warning label in the driver's field of vision. This can be obtained at a qualified specialist workshop.

Under these circumstances, you should also restrict the maximum speed of the vehicle using permanent SPEEDTRONIC so that it does not exceed the maximum permissible speed for the M+S tyres (▷ page 193).

When you have fitted the M+S tyres:

- ▶ Check the tyre pressures (▷ page 565).
- ▶ Restart the tyre pressure monitor (▷ page 569).

For more information on driving with the emergency spare wheel, see (▷ page 579).

Snow chains

WARNING

If you have fitted snow chains to the front wheels, they may scrape against the vehicle body or chassis components. This could cause damage to the vehicle or the tyres. There is a risk of an accident.

To avoid hazardous situations:

- never fit snow chains on the front wheels
- fit snow chains to the rear wheels in pairs.

For safety reasons, Mercedes-Benz recommends that you only use snow chains that have been specially approved for your vehicle by Mercedes-Benz, or that are of a corresponding standard of quality.

If you intend to fit snow chains, please bear the following points in mind:

- snow chains cannot be fitted to all wheel-tyre combinations. Permissible wheel-tyre combinations (▷ page 575).
 - only use snow chains when the road surface is completely snow-covered. Remove the snow chains as soon as possible when you come to a road that is not snow-covered.
 - local regulations may restrict the use of snow chains. Observe the appropriate regulations if you wish to fit snow chains.
 - do not exceed the maximum permissible speed of 50 km/h.
 - on vehicles with Active Body Control (ABC), you must drive at a raised vehicle level if snow chains have been fitted (▷ page 196).
- i** You may wish to deactivate ESP® when pulling away with snow chains fitted (▷ page 75). This way you can allow the wheels to spin in a controlled manner, achieving an increased driving force (cutting action).

For more information on driving with the emergency spare wheel, see (▷ page 579).

Tyre pressure

Tyre pressure specifications

WARNING

Tyres with too low or too high tyre pressure contain the following hazards:

- they can burst, in particular if the vehicle is heavily laden or when driven at high speeds.
- the tyres can wear excessively and/or unevenly, which can severely impair tyre traction.
- the driving, steering and braking characteristics may be severely impaired.

There is a risk of accident.

Follow recommended tyre inflation pressures and check the pressure of all the tyres including the spare wheel:

- at least every two weeks
- if the load changes
- before beginning a long journey
- for changed operating conditions, e.g. off-road driving

If necessary, correct the tyre pressure.

WARNING

If you fit unsuitable accessories onto tyre valves, the tyre valves may be overloaded and malfunction, which can cause tyre pressure loss. Due to their design, retrofitted tyre pressure monitors keep the tyre valve open. This can also result in tyre pressure loss. There is a risk of accident.

Only screw standard valve caps or valve caps specifically provided by Mercedes-Benz for your vehicle onto the tyre valve.

WARNING

If the tyre pressure drops repeatedly, the wheel, valve or tyre may be damaged. Tyre pressure that is too low may result in a tyre blow-out. There is a risk of accident.

- Check the tyre for foreign objects.
- Check whether the wheel is losing air or the valve is leaking.

If you are unable to rectify the damage, contact a qualified specialist workshop.

Environmental note

Check the tyre pressure regularly, at least every 14 days.

You will find a table of tyre pressures for various operating conditions on the inside of your vehicle's fuel filler flap.

The table inside the fuel filler flap may state tyre pressures for different load conditions. These are defined in the table as different numbers of passengers and amounts of luggage. The actual number of seats may vary; for more information, please refer to the vehicle's registration documents.

If tyre sizes are not specified, the tyre pressures stated on the tyre pressure information label apply for all tyres approved for this vehicle.

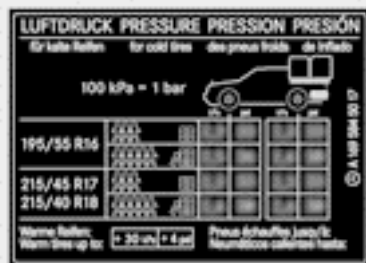

LUFTDRUCK	PRESSURE	PRESSION	PRESSION
for cold tyres	for cold tyres	des pneus froids	de froids
100 kPa = 1 bar			
195/55 R16	2.0 bar	2.0 bar	2.0 bar
215/45 R17	2.2 bar	2.2 bar	2.2 bar
215/40 R18	2.2 bar	2.2 bar	2.2 bar

Warme Reifen:
Warm tires up to: 2.3 bar / 2.3 bar

Pressure (inflating) limit(s):
Maximum allowed load

P40 00-2183-31

If a tyre size precedes a tyre pressure, the following tyre pressure information is only valid for that tyre size.

Use a suitable pressure gauge to check the tyre pressure. The outer appearance of a tyre does not permit any reliable conclusion about the tyre pressure. On vehicles fitted with the electronic tyre pressure monitor, the tyre pressure can be checked using the on-board computer.

If possible, only correct tyre pressures when the tyres are cold.

The tyres are cold:

- if the vehicle has been parked with the tyres out of direct sunlight for at least three hours and
- if the vehicle has not been driven further than 1.6 km

Depending on the ambient temperature, the speed at which you are driving and the load on the tyres, the tyre temperature and thus the tyre pressure change by approximately 10 kPa per 10 °C (0.1 bar/1.5 psi). Take this into account when checking the pressure of warm tyres. Only correct the tyre pressure if it is too low for the current operating conditions.

Driving with tyre pressure that is too high or too low can:

- shorten the service life of the tyres
- cause increased tyre damage
- have a negative effect on handling characteristics and thus the driving safety (e.g. aquaplaning)

i The tyre pressure values given for low loads are minimum values which offer you good ride comfort characteristics.

However, you can also use the values given for higher loads. These are permissible and will not adversely affect the running of the vehicle.

Tyre pressure loss warning system

Important safety notes

While the vehicle is in motion, the tyre pressure loss warning system monitors the set tyre pressure using the rotational speed of the wheels. This enables the system to detect significant pressure loss in a tyre. If the speed of rotation of a wheel changes as a result of a loss of pressure, a corresponding warning message will appear in the multifunction display.

The tyre pressure warning system does not warn you of an incorrectly set tyre pressure. Observe the notes on the recommended tyre pressure (▷ page 565).

The tyre pressure loss warning does not replace the need to regularly check the tyre pressures. An even loss of pressure on several tyres at the same time cannot be detected by the tyre pressure loss warning system.

The tyre pressure monitor is not able to warn you of a sudden loss of pressure, e.g. if the tyre is penetrated by a foreign object. In the event of a sudden loss of pressure, bring the vehicle to a halt by braking carefully. Avoid abrupt steering manoeuvres.

The function of the tyre pressure loss warning system is limited or delayed if:





- snow chains are fitted to your vehicle's tyres.
- road conditions are wintry.
- you are driving on sand or gravel.
- you adopt a very sporty driving style (cornering at high speeds or driving with high rates of acceleration).
- you drive with a heavy load.

Restarting the tyre pressure loss warning system





Restart the tyre pressure loss warning system if you have:

- changed the tyre pressure
- changed the wheels or tyres
- fitted new wheels or tyres
- ▶ Before restarting, make sure that the tyre pressures are set properly on all four tyres for the respective operating conditions. The recommended tyre pressures can be found in the table on the fuel filler flap. The tyre pressure loss warning system can only give reliable warnings if you have set the correct tyre pressure. If an incorrect





tyre pressure is set, these incorrect values will be monitored.

- ▶ Observe the notes on tyre pressure (▷ page 565).
- ▶ Make sure that the key is in position **2** in the ignition lock (▷ page 153).
- ▶ Press the  or  button on the steering wheel to select the **Serv.** menu.
- ▶ Press the  or  button to select **Tyre pressure**.
- ▶ Press the  button. The **Run Flat Indicator active Restart with OK** message appears in the multifunction display.

If you wish to confirm the restart:

- ▶ Press the  button. The **Tyre press. now OK?** message appears in the multifunction display.
- ▶ Press the  or  button to select **Yes**.
- ▶ Press the  button. The **Run Flat Indicator restarted** message appears in the multifunction display. After a teach-in period, the tyre pressure loss warning system will monitor the set tyre pressures of all four tyres.

If you wish to cancel the restart:

- ▶ Press the  button.
- or
- ▶ When the **Tyre pressure now OK?** message appears, press the  or  button to select **Cancel**.
- ▶ Press the  button. The tyre pressure values stored at the last restart will continue to be monitored.

Tyre pressure monitor

Important safety notes

It is the driver's responsibility to set the tyre pressure to the recommended cold tyre pressure suitable for the operating situation (▷ page 565). Note that the correct tyre pressure for the current operating situation must first be taught-in to the tyre pressure monitor. If there is a substantial loss of pressure, the warning threshold for the warning message is aligned to the reference values taught-in. Restart the tyre pressure monitor after adjusting to the cold tyre pressure (▷ page 569). The current pressures are saved as new reference values. This will ensure that a warning message will only appear if the tyre pressure drops significantly. The tyre pressure monitor does not warn you of an incorrectly set tyre pressure. Observe the notes on the recommended tyre pressure (▷ page 565).

The tyre pressure monitor is not able to warn you of a sudden loss of pressure, e.g. if the tyre is penetrated by a foreign object. In the event of a sudden loss of pressure, bring the vehicle to a halt by braking carefully. Avoid abrupt steering manoeuvres.

If a tyre pressure monitor system is fitted, the vehicle's wheels have sensors fitted that monitor the tyre pressures in all four tyres. The tyre pressure monitor warns you if the pressure drops in one or more of the tyres. The tyre pressure monitor only functions if the correct sensors are fitted to all wheels.





Information on tyre pressures is shown in the multifunction display. After a few minutes of driving, the current tyre pressure of each tyre is shown in the multifunction display.

The tyre pressure values indicated by the on-board computer may differ from those measured at a filling station using a pressure gauge. The tyre pressures shown by the on-board computer refer to those measured at sea level. At high altitudes, the tyre pressure values indicated by a pressure gauge are

higher than those shown by the on-board computer. In this case, do not reduce the tyre pressures.

The operation of the tyre pressure monitor can be affected by interference from radio transmitting equipment (e.g. radio headphones, two-way radios) that may be being operated in or near the vehicle.

Checking the tyre pressure electronically

- ▶ Make sure that the key is in position **2** (▷ page 153) in the ignition lock.
- ▶ Press the  or  button on the steering wheel to select the **Serv.** menu.
- ▶ Press the  or  button to select **Tyre pressure**.
- ▶ Press the  button.

The current tyre pressure for each wheel will be displayed in the multifunction display.

If the vehicle has been parked for longer than 20 minutes, the **Tyre pressures will be displayed after a few minutes of driving** message appears.

After a teach-in period, the tyre pressure monitor automatically recognises new wheels or new sensors. As long as a clear allocation of the tyre pressure values to the individual wheels is not possible, the **Tyre pressure monitor active** message is shown instead of the tyre pressure display. The tyre pressures are already being monitored.

Warning messages of the tyre pressure monitor

If the tyre pressure monitor detects a significant pressure loss on one or more tyres, a warning message is shown in the multifunction display. A warning tone also sounds and the tyre pressure warning lamp lights up in the instrument cluster.

Each tyre that is affected by a significant loss of pressure is highlighted in the pressure display.

► If the **Please correct tyre pressure** message appears in the multifunction display, check the tyre pressure on all four wheels and correct it if necessary.

i If the wheel positions on the vehicle are interchanged, the tyre pressures may be displayed for the wrong positions for a short time. This is rectified after a few minutes of driving and the tyre pressures are displayed for the correct positions.



Restarting the tyre pressure monitor

When you restart the tyre pressure monitor, all existing warning messages are deleted and the warning lamps go out. The monitor uses the currently set tyre pressures as the reference values for monitoring. In most cases, the tyre pressure monitor will automatically detect the new reference values after you have changed the tyre pressure. However, you can also define reference values manually as described here.

► Use the table on the inside of the fuel filler flap to ensure that the tyre pressure is set correctly in all four tyres for the current operating conditions.

Observe the notes on tyre pressure (▷ page 565).

► Make sure that the key is in position **2** in the ignition lock.

► Press  or  on the steering wheel to select the **Serv.** menu.

► Press the  or  button to select **Tyre pressure**.

► Press the  button.

The multifunction display shows the current tyre pressure for the individual tyres or the **Tyre pressures will be dis-**

played after a few minutes of driving message.

► Press the  button.

The **Use current pressures as new reference values** message appears in the multifunction display.

If you wish to confirm the restart:

► Press the  button.

The **Tyre press. monitor restarted** message appears in the multifunction display.

After you have driven for a few minutes, the system checks whether the current tyre pressures are within the specified range.

The new tyre pressures are then accepted as reference values and monitored.

If you wish to cancel the restart:

► Press the  button.

The tyre pressure values stored at the last restart will continue to be monitored.

Radio type approval for the tyre pressure monitor

Country	Radio type approval number
Brazil	1489-10-4415 Model: MRXMERCX1
Dubai	TRA Registered-NO: 0016161/08 Registered-NO: 0016162/08 Dealer-NO: DA0047074/10
Morocco	MR5527 ANRT 2010/ 27. April 2010 MR5526 ANRT 2010/ 27. April 2010
Philippines	ESD-1105558C

Country	Radio type approval number
Singapore	Compliance with IDA Standard N0140-09
South Africa	TA-2008/1068 TA-2008/1069

Changing a wheel

Flat tyre

Information on the procedure in the event of a flat tyre (▷ page 546). You will also find information on driving with MOExtended tyres in the event of a flat tyre.

Interchanging the wheels

WARNING

Interchanging the front and rear wheels may severely impair the driving characteristics if the wheels or tyres have different dimensions. The wheel brakes or suspension components may also be damaged. There is a risk of accident.

Interchange front and rear wheels only if the wheels and tyres are of the same dimensions.

! On vehicles fitted with a tyre pressure monitor, electronic components are located in the wheel.

Tyre-fitting tools should not be applied in the area of the valve, as this could damage the electronic components.

Only have tyres changed at a qualified specialist workshop.

Interchanging the front and rear wheels of differing dimensions can render the general operating permit invalid.

Always pay attention to the instructions and safety notes when changing a wheel (▷ page 571).

The wear patterns on the front and rear tyres differ, depending on the operating conditions. Interchange the wheels before a clear wear

pattern has formed on the tyres. Front tyres typically wear more on the shoulders and the rear tyres in the centre.

On vehicles that have the same size front and rear wheels, you can interchange the wheels every 5,000km to 10,000 km depending on the degree of tyre wear. Maintain the direction of tyre rotation.

Clean the contact surfaces of the wheel and the brake disc thoroughly every time a wheel is interchanged. Check the tyre pressure and, if necessary, restart the tyre pressure loss warning system or the tyre pressure monitor.

Direction of rotation

Tyres with a specified direction of rotation have additional benefits, e.g. if there is a risk of aquaplaning. You will only gain these benefits if the correct direction of rotation is observed.

An arrow on the sidewall of the tyre indicates its correct direction of rotation.

Storing wheels

Store wheels that are not being used in a cool, dry and preferably dark place. Protect the tyres against oil, grease, petrol and diesel.

Cleaning the wheels

WARNING

The water jet of circular-jet nozzles (dirt grinders) can cause damage not visible from the outside to tyres or chassis components. Components damaged in this way can unexpectedly fail. There is a risk of an accident.

Do not use high-pressure cleaners with circular-jet nozzles to clean the vehicle. Have damaged tyres or chassis components replaced immediately.

Fitting a wheel

Preparing the vehicle

- ▶ Stop the vehicle on solid, non-slippery and level ground.
 - ▶ Unload the vehicle. The jack can only be used when the vehicle is unladen.
 - ▶ Engage the electric parking brake manually.
 - ▶ Bring the front wheels into the straight-ahead position.
 - ▶ Shift the transmission to position **P**.
 - ▶ Switch off the engine.
 - ▶ **Vehicles without KEYLESS-GO:** remove the key from the ignition lock.
 - ▶ **Vehicles with KEYLESS-GO:** open the driver's door.
The on-board electronics have status **0**, which is the same as the key having been removed.
 - ▶ **Vehicles with KEYLESS-GO:** remove the Start/Stop button from the ignition lock (▷ page 153).
 - ▶ If included in the vehicle equipment, remove the tyre-change tool kit from the vehicle.
 - ▶ Secure the vehicle to prevent it from rolling away.
- i** Apart from certain country-specific variations, vehicles are not equipped with a tyre-change tool kit. For information on which tools are required to perform a wheel change on your vehicle, consult a Mercedes-Benz Service Centre.
- Necessary wheel-changing tools can include, for example:
- jack
 - wheel chock
 - wheel wrench

Securing the vehicle against rolling away

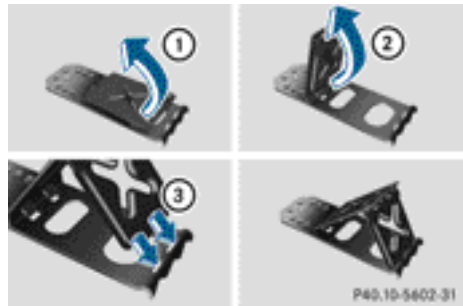

If your vehicle is equipped with a wheel chock, it can be found in the tyre-change tool kit (▷ page 545).

The folding wheel chock is an additional securing measure to prevent the vehicle from rolling away, for example when changing a wheel.

- ▶ Fold both plates upwards ①.
- ▶ Fold out lower plate ②.
- ▶ Guide the lugs on the lower plate fully into the openings in base plate ③.

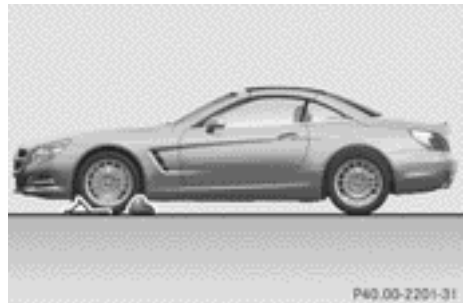

Securing the vehicle on level ground

- ▶ **On level ground:** place chocks or other suitable items under the front and rear of the wheel that is diagonally opposite the wheel you wish to change.

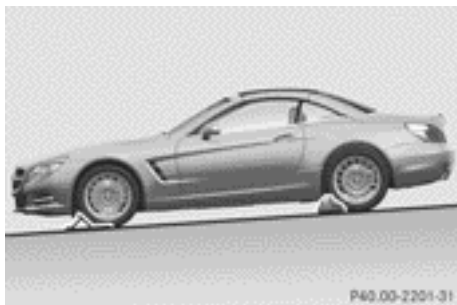

Securing the vehicle on slight downhill gradients

- ▶ **On light downhill gradients:** place chocks or other suitable items in front of the wheels of the front and rear axle.

Raising the vehicle

WARNING

If you do not position the jack correctly at the appropriate jacking point of the vehicle, the jack could tip over with the vehicle raised. There is a risk of injury.

Only position the jack at the appropriate jacking point of the vehicle. The base of the jack must be positioned vertically, directly under the jacking point of the vehicle.

The following must be observed when raising the vehicle:

- to raise the vehicle, only use the vehicle-specific jack that has been tested and approved by Mercedes-Benz. If the jack is used incorrectly, it could tip over while the vehicle is raised.
- the jack is designed only to raise and hold the vehicle for a short time while a wheel is being changed. It is not suited for performing maintenance work under the vehicle.
- avoid changing the wheel on uphill and downhill slopes.
- before raising the vehicle, secure it from rolling away by applying the parking brake and inserting wheel chocks. Never disengage the parking brake while the vehicle is raised.

- the jack must be placed on a firm, flat and non-slip surface. On a loose surface, a large, load-bearing underlay must be used. On a slippery surface, a non-slip underlay must be used, e.g. rubber mats.
- do not use wooden blocks or similar objects as a jack underlay. Otherwise, the jack will not be able to achieve its load-bearing capacity due to the restricted height.
- make sure that the distance between the underside of the tyres and the ground does not exceed 3 cm.
- never place your hands or feet under the raised vehicle.
- never lie under the raised vehicle.
- never start the engine when the vehicle is raised.
- never open or close a door or the boot lid when the vehicle is raised.
- make sure that no persons are present in the vehicle when the vehicle is raised.

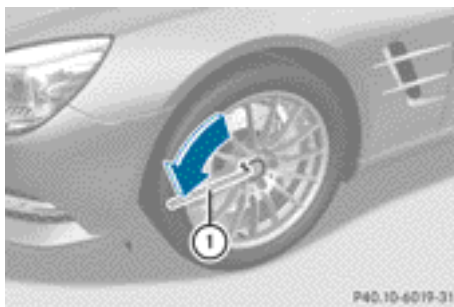

- ▶ Using wheel wrench ①, loosen the bolts on the wheel you wish to change by about one full turn. Do not unscrew the bolts completely.

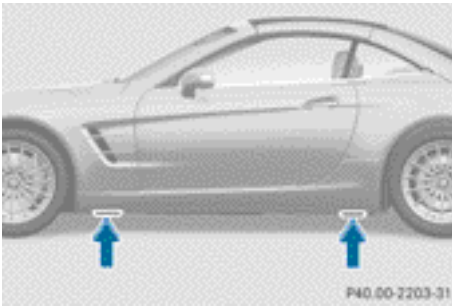

The jacking points are located just behind the front wheel arches and just in front of the rear wheel arches (arrows).

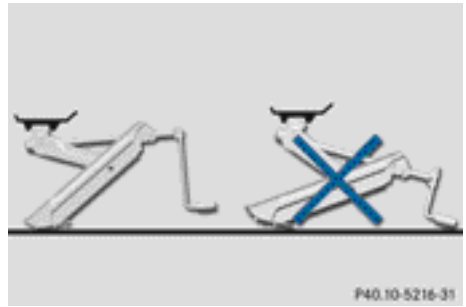

Example

- ▶ Make sure that the base of the jack is positioned vertically under the jacking point.
- ▶ Turn crank ⑤ clockwise until jack ④ sits completely on jacking point ③ and the base of the jack lies evenly on the ground.
- ▶ Turn crank ⑤ until the tyre is raised a maximum of 3 cm off the ground.

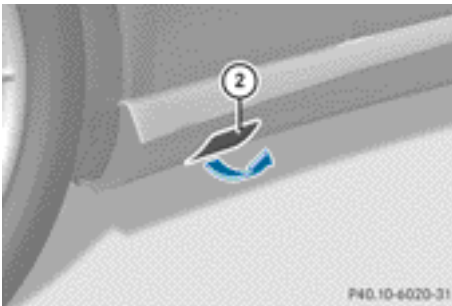

Covers, front (example: vehicles with AMG equipment)

AMG vehicles and vehicles with AMG equipment: the vehicle has covers fitted next to the jacking points on the outer sills to protect the vehicle body.

- ▶ **AMG vehicles and vehicles with AMG equipment:** fold cover ② upwards.

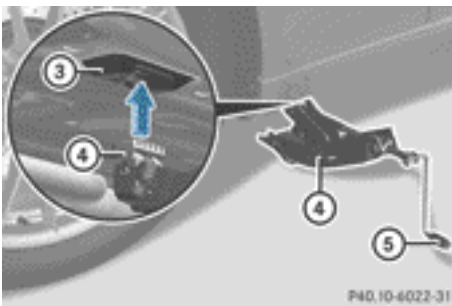

- ▶ Position jack ④ at jacking point ③.

Removing a wheel

! **AMG vehicles:** during removal and repositioning of the wheel, the wheel rim can strike the ceramic-brake disc and damage it. Therefore, take precautions and get a second person to assist you. Alternatively, you can use a second centring pin.

! Do not place wheel bolts in sand or dirt. The threads of the wheel bolts and wheel hubs could otherwise be damaged when the bolts are tightened.

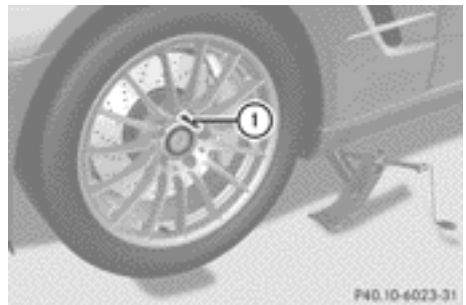

- ▶ Unscrew the uppermost wheel bolt completely.
- ▶ Screw centring pin ① into the thread instead of the wheel bolt.
- ▶ Unscrew the remaining wheel bolts fully.
- ▶ Remove the wheel.

Fitting a new wheel

WARNING

Oiled or greased wheel bolts or damaged wheel bolts/hub threads can cause the wheel bolts to come loose. As a result, you could lose a wheel while driving. There is a risk of accident.

Never oil or grease wheel bolts. In the event of damage to the threads, contact a qualified specialist workshop immediately. Have the damaged wheel bolts or hub threads replaced/renewed. Do not continue driving.

WARNING

If you tighten the wheel bolts or wheel nuts when the vehicle is raised, the jack could tip over. There is a risk of injury.

Only tighten the wheel bolts or wheel nuts when the vehicle is on the ground.

Always pay attention to the instructions and safety notes in "Changing a wheel" (▷ page 570).

Only use wheel bolts that have been designed for the wheel and the vehicle. For safety reasons, Mercedes-Benz recommends that you only use wheel bolts which have been approved for Mercedes-Benz vehicles and the respective wheel.

! **AMG vehicles:** during removal and repositioning of the wheel, the wheel rim can strike the ceramic-brake disc and damage it. Therefore, take precautions and get a second person to assist you. Alternatively, you can use a second centring pin.



- ▶ Clean the wheel and wheel hub contact surfaces.
- ▶ Slide the wheel to be mounted onto the centring pin and push it on.
- ▶ Tighten the wheel bolts until they are finger-tight.
- ▶ Unscrew the centring pin.
- ▶ Tighten the last wheel bolt until it is finger-tight.
- ▶ **Vehicles with a collapsible emergency spare wheel:** inflate the collapsible emergency spare wheel (▷ page 581). Only then lower the vehicle.

Lowering the vehicle

WARNING

The wheels could work loose if the wheel nuts and bolts are not tightened to the specified tightening torque. There is a risk of accident.

Have the tightening torque immediately checked at a qualified specialist workshop after a wheel is changed.

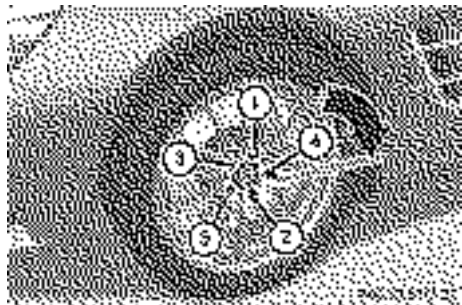

- ▶ Turn the crank of the jack anti-clockwise until the vehicle is once again standing firmly on the ground.
 - ▶ Place the jack to one side.
 - ▶ Tighten the wheel bolts evenly in a cross-wise pattern in the sequence indicated (① to ⑤). The tightening torque must be **130 Nm**.
 - ▶ Turn the jack back to its initial position.
 - ▶ Stow the jack and the rest of the vehicle tools in the boot again.
 - ▶ **AMG vehicles and vehicles with AMG equipment:** insert the cover into the outer sill.
 - ▶ Check the air pressure of the newly fitted wheel and adjust accordingly.
Observe the recommended tyre pressure (▷ page 565).
- i** Vehicles with tire pressure control system: all fitted wheels must be equipped with functioning sensors.

Wheel and tyre combinations

General notes

! For safety reasons, Mercedes-Benz recommends that you only use tyres and wheels which have been approved by Mercedes-Benz specifically for your vehicle.

These are specially adapted to the control systems, such as ABS or ESP® and are marked as follows:

- MO = Mercedes-Benz Original
- MOE = Mercedes-Benz Original Extended (tyres featuring run-flat characteristics)
- MO1 = Mercedes-Benz Original (only certain AMG tyres)

Mercedes-Benz Original Extended tyres may only be used on wheels that have been specifically approved by Mercedes-Benz.

Only use tyres, wheels or accessories tested and approved by Mercedes-Benz. Cer-

tain characteristics, e.g. handling, vehicle noise emissions or fuel consumption, may otherwise be adversely affected. In addition, when driving with a load, tyre dimension variations could cause the tyres to come into contact with the bodywork and axle components. This could result in damage to the tyres or the vehicle.

Mercedes-Benz accepts no liability for damage resulting from the use of tyres, wheels or accessories other than those tested and approved.

Further information about wheels, tyres and approved combinations can be obtained from any qualified specialist workshop.

! Retreaded tyres are neither tested nor recommended by Mercedes-Benz, since previous damage cannot always be detected on retreaded tyres. As a result, Mercedes-Benz cannot guarantee vehicle safety if retreaded tyres are fitted. Do not fit used tyres if you have no information about their previous usage.

! Large wheels: the lower the section width for a certain wheel size, the lower the ride comfort is on poor road surfaces. Roll comfort and suspension comfort are reduced and the risk of damage to the wheels and tyres as a result of driving over obstacles increases.

Overview of abbreviations used in the following tyre tables:

- BA: both axles
- FA: front axle
- RA: rear axle

You will find a table with recommended tyre pressures for various operating conditions on the inside of your vehicle's fuel filler flap. For further information on tyre pressure, see (▷ page 565). Check tyre pressures regularly and only when the tyres are cold.

Notes on the vehicle equipment – always fit the vehicle:

- with tyres of the same size on a given axle (left/right)
- with the same type of tyres at a given time (summer tyres, winter tyres, MOExtended tyres)

Vehicles with MOExtended tyres are not equipped with a TIREFIT kit at the factory. It is therefore recommended that you additionally equip your vehicle with a TIREFIT kit if you fit tyres that do not feature run-flat characteristics, e.g. winter tyres. A TIREFIT kit can be obtained from a qualified specialist workshop.

- i** Not all wheel/tyre combinations can be mounted at the factory in all countries.

Tyres**SL 350****Summer tyres****R17**

Tyres	Light-alloy wheels
BA: 255/45 R17 98 Y	BA: 8.0 J x 17 H2 ET 30

R18

Tyres	Light-alloy wheels
BA: 255/40 R18 95 Y	BA: 8.5 J x 18 H2 ET 35.5
BA: 255/40 R18 95 Y MOExtended ¹	BA: 8.5 J x 18 H2 ET 35.5
FA: 255/40 R18 95 Y RA: 285/35 R18 97 Y ²	FA: 8.5 J x 18 H2 ET 35.5 RA: 9.5 J x 18 H2 ET 47.5
FA: 255/40 R18 95 Y MOExtended ¹ RA: 285/35 R18 97 Y MOExtended ^{1, 2}	FA: 8.5 J x 18 H2 ET 35.5 RA: 9.5 J x 18 H2 ET 47.5

R19

Tyres	Light-alloy wheels
FA: 255/35 R19 96 Y XL ³ RA: 285/30 R19 98 Y XL ^{2, 3}	FA: 8.5 J x 19 H2 ET 35.5 RA: 9.5 J x 19 H2 ET 47.5
FA: 255/35 R19 96 Y XL MOExtended ^{1, 3} RA: 285/30 R19 98 Y XL MOExtended ^{1, 2, 3}	FA: 8.5 J x 19 H2 ET 35.5 RA: 9.5 J x 19 H2 ET 47.5
FA: 255/35 R19 96 Y XL ³ RA: 285/30 R19 98 Y XL ^{2, 3}	FA: 8.5 J x 19 H2 ET 35.5 RA: 9.5 J x 19 H2 ET 48
FA: 255/35 R19 96 Y XL MOExtended ^{1, 3} RA: 285/30 R19 98 Y XL MOExtended ^{1, 2, 3}	FA: 8.5 J x 19 H2 ET 35.5 RA: 9.5 J x 19 H2 ET 48

¹ MOExtended tyres (tyres featuring run-flat characteristics) only in combination with an activated tyre pressure loss warning system or tyre pressure monitor.

² The use of snow chains is not permitted. Observe the notes in the "Snow chains" section.



³ Observe notes on "large wheels" in the "Wheel/tyre combinations" section.

Winter tyres

R17

Tyres	Light-alloy wheels
BA: 255/45 R17 98 V M+S 	BA: 8.0 J x 17 H2 ET 30

R18

Tyres	Light-alloy wheels
BA: 255/40 R18 99 V XL M+S 	BA: 8.5 J x 18 H2 ET 35.5
BA: 255/40 R18 99 V XL M+S  MOExtended ¹	BA: 8.5 J x 18 H2 ET 35.5

SL 500

Summer tyres

R18

Tyres	Light-alloy wheels
FA: 255/40 R18 95 Y	FA: 8.5 J x 18 H2 ET 35.5
FA: 285/35 R18 97 Y ²	RA: 9.5 J x 18 H2 ET 47.5
FA: 255/40 R18 95 Y MOExtended ¹	FA: 8.5 J x 18 H2 ET 35.5
RA: 285/35 R18 97 Y MOExtended ^{1, 2}	RA: 9.5 J x 18 H2 ET 47.5

R19

Tyres	Light-alloy wheels
FA: 255/35 R19 96 Y XL ³	FA: 8.5 J x 19 H2 ET 35.5
RA: 285/30 R19 98 Y XL ^{2, 3}	RA: 9.5 J x 19 H2 ET 47.5
FA: 255/35 R19 96 Y XL MOExtended ^{1, 3}	FA: 8.5 J x 19 H2 ET 35.5
RA: 285/30 R19 98 Y XL MOExtended ^{1, 2, 3}	RA: 9.5 J x 19 H2 ET 47.5
FA: 255/35 R19 96 Y XL ³	FA: 8.5 J x 19 H2 ET 35.5
RA: 285/30 R19 98 Y XL ^{2, 3}	RA: 9.5 J x 19 H2 ET 48
FA: 255/35 R19 96 Y XL MOExtended ^{1, 3}	FA: 8.5 J x 19 H2 ET 35.5
RA: 285/30 R19 98 Y XL MOExtended ^{1, 2, 3}	RA: 9.5 J x 19 H2 ET 48



¹ MOExtended tyres (tyres featuring run-flat characteristics) only in combination with an activated tyre pressure loss warning system or tyre pressure monitor.

² The use of snow chains is not permitted. Observe the notes in the "Snow chains" section.

³ Observe notes on "large wheels" in the "Wheel/tyre combinations" section.

Winter tyres

R18

Tyres	Light-alloy wheels
BA: 255/40 R18 99 V XL M+S 	BA: 8.5 J x 18 H2 ET 35.5
BA: 255/40 R18 99 V XL M+S  MOExtended ¹	BA: 8.5 J x 18 H2 ET 35.5

AMG vehicles



Summer tyres

R19/R20

Tyres	Light-alloy wheels
FA: 255/35 ZR19 (96 Y) XL ³	FA: 9.0 J x 19 H2 ET 27
RA: 285/30 ZR19 (98 Y) XL ³	RA: 10.0 J x 19 H2 ET 48
FA: 255/35 ZR19 (96 Y) XL ³	FA: 9.0 J x 19 H2 ET 27
RA: 285/30 ZR20 (99 Y) XL ^{2,3}	RA: 10.0 J x 20 H2 ET 48

Winter tyres

R19

Tyres	Light-alloy wheels
FA: 255/35 R19 96 V XL M+S  ³	FA: 9.0 J x 19 H2 ET 27
RA: 285/30 R19 98 V XL M+S  ³	RA: 10.0 J x 19 H2 ET 48

Emergency spare wheel

Important safety notes

 **WARNING**

The wheel/tyre dimensions and the tyre type of the spare wheel/emergency spare wheel and the wheel to be replaced may differ. Fitting a spare wheel/emergency spare wheel may severely impair the driving characteristics. There is a risk of accident.

To prevent hazardous situations:

- Adapt your driving style accordingly and drive carefully.
- Never fit more than one spare wheel/emergency spare wheel if the dimensions are different to those of the wheel being replaced.
- Only use a spare wheel/emergency spare wheel briefly if the dimensions are different to those of the wheel being replaced.
- Do not switch off ESP®.
- Have the spare wheel/emergency spare wheel in question replaced at the nearest

¹ MOExtended tyres (tyres featuring run-flat characteristics) only in combination with an activated tyre pressure loss warning system or tyre pressure monitor.

³ Observe notes on "large wheels" in the "Wheel/tyre combinations" section.

² The use of snow chains is not permitted. Observe the notes in the "Snow chains" section.

qualified specialist workshop. Make sure that the wheel/tyre dimensions and tyre type are correct.

When using an emergency spare wheel or spare wheel of a different size, you must not exceed the maximum speed of 80 km/h. Snow chains must not be fitted to emergency spare wheels.

General notes

You should regularly check the pressure of all your tyres, including the emergency spare wheel, particularly prior to long trips, and correct the pressure as necessary (▷ page 565). The applicable value is found on the wheel or under "Technical data" (▷ page 582).

An emergency spare wheel may also be fitted against the direction of rotation. Observe the time restriction on use as well as the speed limitation specified on the emergency spare wheel.

Replace the tyres after six years at the latest, regardless of wear. This also applies to the emergency spare wheel.

- i** When you are driving with the collapsible emergency spare wheel fitted, the tyre pressure loss warning system or the tyre pressure monitor cannot function reliably. Only restart the tyre pressure loss warning system/tyre pressure monitor when the defective wheel has been replaced with a new wheel.

Vehicles with tyre pressure monitor:

after mounting an emergency spare wheel, the system may still display the tyre pressure of the removed wheel for a few minutes. The value displayed for the mounted emergency spare wheel is not the same as the current tyre pressure of the emergency spare wheel.

Removing the emergency spare wheel

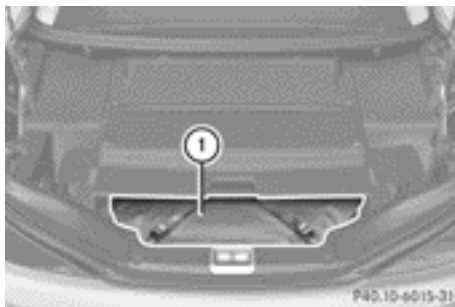

Vehicles with a collapsible spare wheel

- ▶ Open the boot.
- ▶ Open the boot separator (▷ page 105).
- ▶ Remove the bag with collapsible emergency spare wheel ①.

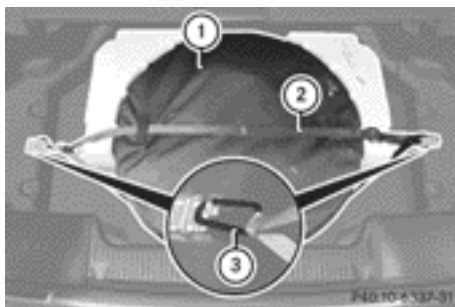

Vehicles with a spare wheel

The spare wheel is packed in bag ① and secured in the boot.

- ▶ Open the boot.
- ▶ Open the boot separator (▷ page 105).
- ▶ Loosen tensioning strap ② on both sides.
- ▶ Unhook retaining spring hooks ③ of tensioning strap ② from the retainers.
- ▶ Remove bag ① with the spare wheel.
- ▶ Open bag ① and remove the spare wheel.

Information on the tyre-change tool kit can be found in the "Where will I find...?" section (▷ page 545).

Inflating the collapsible emergency spare wheel

! Inflate the collapsible emergency spare wheel using the tyre inflation compressor before lowering the vehicle. The wheel rim could otherwise be damaged.

! Do not operate the tyre inflation compressor for longer than eight minutes at a time without a break. It may otherwise overheat.

The tyre inflation compressor can be operated again once it has cooled down.

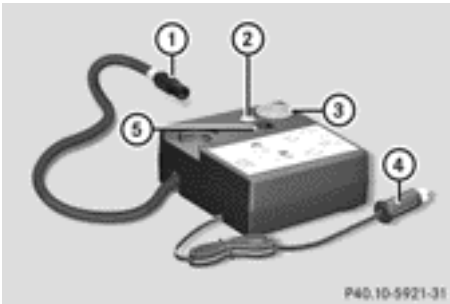

- ▶ Mount the collapsible emergency spare wheel as described (▷ page 571).
The collapsible emergency spare wheel must be mounted before it is inflated.
- ▶ Pull connector (4) and the air hose out of the housing.
- ▶ Remove the cap from the valve on the collapsible emergency spare wheel.
- ▶ Screw union nut (1) on the air hose onto the valve.
- ▶ Make sure on/off switch (5) of the tyre inflation compressor is set to **0**.
- ▶ Insert plug (4) into the socket of the cigarette lighter or into a 12 V of power socket in your vehicle.
Observe the notes on the cigarette lighter (▷ page 518). Observe the notes on sockets (▷ page 518).
- ▶ Turn the key to position **1** in the ignition lock (▷ page 153).

- ▶ Press on/off switch (5) on the tyre inflation compressor to **I**.
The tyre inflation compressor is switched on. The tyre is inflated. The tyre pressure is shown on pressure gauge (3).
- ▶ Pump the tyre to the specified tyre pressure.
The specified tyre pressure is printed on the yellow label of the emergency spare wheel.
- ▶ When the specified tyre pressure has been reached, press on/off switch (5) on the electric air pump to **0**.
The tyre inflation compressor is switched off.
- ▶ Turn the key to position **0** in the ignition lock.
- ▶ If the tyre pressure is higher than the specified pressure, press pressure release button (2) until the correct tyre pressure has been reached.
- ▶ Unscrew union nut (1) on the air hose from the valve.
- ▶ Screw the valve cap onto the collapsible emergency spare wheel valve again.
- ▶ Stow plug (4) and the air hose in the lower section of the compressor housing.
- ▶ Stow the tyre inflation compressor in the vehicle.

Technical data**All models (except AMG vehicles)****Collapsible emergency spare wheel**

Tyres	Light-alloy wheels
175/55- 18 95 P Tyre pressure: 350 kPa(3.5 bar/51 psi)	6.0 B x 18 H2 ET 25

AMG vehicles**Collapsible emergency spare wheel**

Tyres	Light-alloy wheels
175/50- 19 97 P Tyre pressure: 350 kPa (3.5 bar/51 psi)	6.5 B x 19 H2 ET 14

Useful information	584
Information on technical data	584
Genuine Mercedes-Benz parts	584
Vehicle electronics	585
Identification plates	586
Service products and capacities	587
Vehicle data	593
24 GHz radar sensor system	595

Useful information

- i** This Owner's Manual describes all models, series and optional equipment for your vehicle that were available at the time of going to press. National variations are possible. Note that your vehicle may not be equipped with all of the functions described. This is also the case for systems and functions relevant to safety.
- i** Read the information on qualified specialist workshops: (▷ page 38).

Information on technical data

You can find technical data on the Internet at: <http://www.mercedes-benz.com>

- i** The technical data was determined in accordance with EC Directives. All data applies to the vehicle's standard equipment. It may therefore differ for vehicles with optional equipment. You can obtain further information from a Mercedes-Benz Service Centre.

Genuine Mercedes-Benz parts

WARNING

Driving safety may be impaired if non-approved parts, tyres and wheels or safety-relevant accessories are used.

This could lead to malfunctions in safety-relevant systems, e.g. the brake system. This could cause you to lose control of your vehicle and cause an accident.

For this reason, Mercedes-Benz recommends that you use genuine Mercedes-Benz parts or parts of equal quality. Only use tyres, wheels and accessories that have been specifically approved for your vehicle.

Environmental note

Daimler AG also supplies reconditioned assemblies and parts which are of the same quality as new parts. For these, the same warranty applies as for new parts.

- !** Airbags and seat belt tensioners, as well as control units and sensors for these restraint systems, may be installed in the following areas of your vehicle:

- doors
- door pillars
- door sills
- seats
- dashboard
- instrument cluster
- centre console

Do not install accessories such as audio systems in these areas. Do not carry out repairs or welding. You could impair the operating efficiency of the restraint systems.

Have accessories retrofitted at a qualified specialist workshop.

Mercedes-Benz tests genuine parts and conversion parts and accessories that have been specifically approved for your vehicle for their reliability, safety and suitability. Despite ongoing market research, Mercedes-Benz is unable to assess other parts. Mercedes-Benz accepts no responsibility for the use of parts that have been independently or officially approved.

In Germany, certain parts are only officially approved for installation or modification if they comply with legal requirements. This also applies to some other countries. All genuine Mercedes-Benz parts meet the approval requirements. The use of non-approved parts may invalidate the vehicle's general operating permit.

This is the case:

- if they cause a change of the vehicle type from that for which the vehicle's general operating permit was granted
- if other road users could be endangered
- if the emission or noise levels are adversely affected.

Always specify the vehicle identification number (VIN) (> page 586) and the engine number (> page 587) when ordering genuine Mercedes-Benz parts.

Vehicle electronics

Tampering with the engine electronics

WARNING

Always have work on the engine electronics and related components carried out at a qualified specialist workshop. Otherwise, the vehicle's operating safety could be affected.

- ❗ Only have work carried out on the engine electronics and its associated parts, such as control units, sensors and connector leads, at a qualified specialist workshop. Vehicle components may otherwise wear more quickly and the vehicle's operating permit may be invalidated.

Retrofitting two-way radios and mobile phones (RF transmitters)

WARNING

Incorrect retrofitting of RF transmitters can cause the vehicle electronics to malfunction. The vehicle's operating safety and thus your own safety are impaired.

Have aftermarket radio frequency transmitting equipment installed at a qualified specialist workshop.

WARNING

Incorrect retrofitting of RF transmitters can lead to increased electromagnetic radiation in the vehicle interior. Using an exterior aerial takes into account current scientific discussions relating to the possible health hazards that may result from electromagnetic fields. Have aftermarket radio frequency transmitting equipment installed at a qualified specialist workshop.

- ❗ The operating permit may be invalidated if the instructions for installation and use of RF transmitters are not observed.

In particular, the following conditions must be complied with:

- only approved wavebands may be used.
- the maximum permissible output in these wavebands must be complied with.
- the approved aerial positions must be complied with.

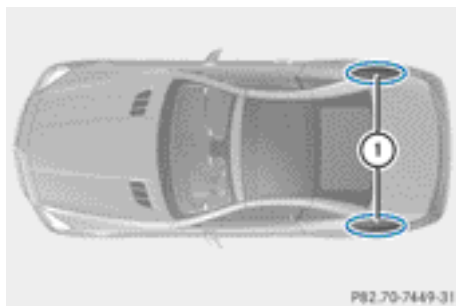

Approved aerial positions

- ① Rear wing

- ❗ On the rear wing, it is recommended that you position the aerial on the side of the vehicle closest to the centre of the road.

Use Technical Specification ISO/TS 21609 (Road Vehicles – "EMC guidelines for fitting aftermarket radio frequency transmitting equipment") when retrofitting RF (radio frequency) transmitters. Comply with the legal requirements for add-on parts.

If your vehicle has fittings for two-way radio equipment, use the power supply or aerial

connections intended for use with the basic wiring. Be sure to observe the manufacturer's additional instructions when installing.

Deviations with respect to wavebands, maximum transmission outputs or aerial positions must be approved by Mercedes-Benz.

The maximum transmission output (PEAK) at the base of the aerial must not exceed the following values:

Waveband	Maximum transmission output
Short wave 3 - 54 MHz	30 W
4 m waveband 68 - 87.5 MHz	15 W
2 m waveband 144 - 174 MHz	25 W
Trunked radio/Tetra 380 - 460 MHz	15 W
70 cm waveband 400 - 460 MHz	15 W
GSM/DCS/PCS 850/900/1800/1900	10 W
UMTS/LTE	10 W

The following can be used in the vehicle without restrictions:

- RF transmitters with a maximum transmission output of up to 100 mW
- mobile phones (GSM/DCS/PCS/UMTS/LTE)

There are no restrictions when positioning the aerial on the outside of the vehicle for the following wavebands:

- Trunked radio/Tetra
- 70 cm waveband
- GSM/DCS/PCS
- UMTS/LTE

Identification plates

Vehicle identification plate with vehicle identification number (VIN)



- Open the right-hand door.
You will see vehicle identification plate ①.

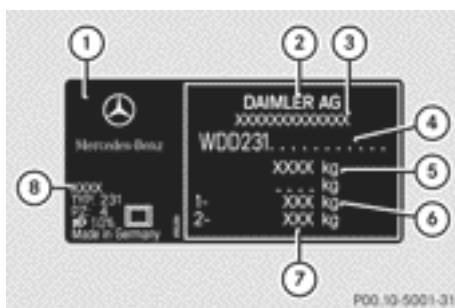

Example: vehicle identification plate

- ① Vehicle identification plate
- ② Vehicle manufacturer (Daimler AG)
- ③ EU type approval number (only for certain countries)
- ④ VIN
- ⑤ Maximum permissible gross vehicle weight (kg)
- ⑥ Maximum permissible front axle load (kg)
- ⑦ Maximum permissible rear axle load (kg)
- ⑧ Paint code

i The data shown on the vehicle identification plate is example data. This data is different for every vehicle and can deviate from the data shown here. You can find the data applicable to your vehicle on the vehicle's identification plate.

VIN

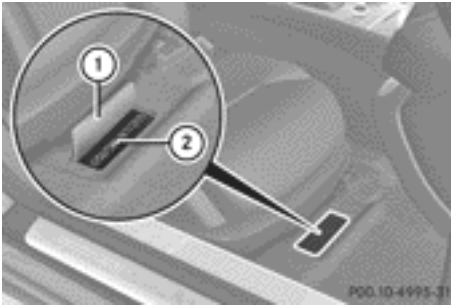

- ▶ Move the front-passenger front seat to its rearmost position.
- ▶ Fold up floor covering ① in front of the front-passenger seat. You will see VIN ②.

The VIN can also be found on the vehicle identification plate (▶ page 586).

Engine number

The engine number is stamped onto the crankcase. You can obtain further information from any qualified specialist workshop.

Service products and capacities

Important safety notes

WARNING

Service product can be poisonous and hazardous to health. There is a risk of injury.

Observe the instructions on the respective original container when using, storing and disposing of service products. Always store service products in the sealed original container. Always keep service products out of the reach of children.

Environmental note

Dispose of service products in an environmentally-responsible manner.

Service products include the following:

- fuels
- lubricants (e.g. engine oil, transmission oil)
- coolant
- brake fluid
- windscreen washer fluid
- climate control system refrigerant

When handling, storing and disposing of any service products, please observe the relevant regulations.

Components and service products must be matched. Mercedes-Benz recommends that you use products tested and approved by Mercedes-Benz. They are listed in this Mercedes-Benz Owner's Manual in the appropriate section.

You can identify service products approved by Mercedes-Benz by the following inscriptions on the container:

- MB-Freigabe (e.g. MB-Freigabe 229.51)
- MB Approval (e.g. MB Approval 229.51)

Other designations or recommendations indicate a level of quality or a specification in accordance with an MB Sheet Number (e.g. MB 229.5). They have not necessarily been approved by Mercedes-Benz.

Further information can be obtained from any Mercedes-Benz Service Centre or on the Internet at <http://bevo.mercedes-benz.com>.

Fuel

Important safety notes

WARNING

Fuel is highly flammable. If you handle fuel incorrectly, there is a risk of fire and explosion.

You must avoid fire, naked flames, creating sparks and smoking. Switch off the engine and, if applicable, the auxiliary heating before refuelling.

⚠ WARNING

Fuels are poisonous and hazardous to health. There is a danger of injury.

Do not swallow fuel or let it come into contact with skin, eyes or clothing. Do not inhale fuel vapours. Keep fuels out of the reach of children.

If you or others come into contact with fuel, observe the following:

- Wash the fuel off any affected areas of skin with water and soap immediately.
- If you get fuel in your eyes, rinse them thoroughly with clean water immediately. Seek immediate medical attention.
- If fuel is swallowed, seek immediate medical attention. Do not induce vomiting.
- Change any clothing that has come into contact with fuel immediately.

Tank capacity

The total capacity of the fuel tank may vary, depending on the vehicle equipment.

Model	Total capacity
All models (except AMG vehicles)	65.0 l or 75.0 l
AMG vehicles	75.0 l

Model	Of which reserve fuel
All models (except AMG vehicles)	Approx. 8.0 l or 9.0 l
AMG vehicles	Approx. 14.0 l

Petrol (EN 228, E DIN 51626-1)**Fuel grade**

! Do not use diesel to refuel vehicles with a petrol engine. Do not switch on the ignition if you accidentally refuel with the wrong fuel. Otherwise, the fuel will enter the fuel system. Even small amounts of the wrong fuel could result in damage to the fuel system and the engine. The repair costs are high. Notify a qualified specialist workshop and have the fuel tank and fuel lines drained completely.

! Only refuel using unleaded petrol with at least 95 RON/85 MON that conforms to European standard EN 228 or E DIN 51626-1 or an equivalent specification. Fuel with this specification may contain up to 10 % ethanol.

! Do not use the following:

- E85 (petrol with 85 % ethanol)
- E100 (100 % ethanol)
- M15 (petrol with 15 % methanol)
- M85 (petrol with 85 % methanol)
- M100 (100 % methanol)
- Petrol with metallic additives
- Diesel

Do not mix these fuels with petrol, and do not use any additives. This can otherwise lead to engine damage. This does not include cleaning additives for the removal and prevention of residue build-up. Only cleaning additives recommended by Mercedes-Benz should be added to petrol, see "Additives". You can obtain further information from any Mercedes-Benz Service Centre.

Usually you will find information about the fuel grade on the pump. If you cannot find the label on the petrol pump, ask the filling station staff.

i E10 fuel contains up to 10% bioethanol. Your vehicle is suitable for use with E10

fuel. You can refuel your vehicle using E10 fuel.

- i** As a temporary measure, if the recommended fuel is not available, you may also use unleaded petrol with an octane rating of 91 RON/82 MON. This may reduce engine performance and increase fuel consumption. Avoid driving at full throttle.

Information on refuelling (▷ page 170).

AMG vehicles

- !** Only refuel using super unleaded petrol with at least 98 RON/88 MON that conforms to European standard EN 228 or an equivalent specification.

You can otherwise impair engine output or damage the engine.

- !** Premium-grade unleaded petrol with an octane rating of 95 RON/85 MON may be used as a temporary measure if the recommended fuel is not available. This may reduce engine performance and increase fuel consumption. As much as possible, avoid driving at full throttle.

- !** Regular unleaded petrol with an octane rating of 91 RON/82.5 MON may also be used as a temporary measure if the recommended fuel is not available.

Doing so results in noticeably higher fuel consumption, and the engine power output is noticeably reduced. Avoid driving at full throttle.

If only regular unleaded petrol with an octane rating of 91 RON/82.5 MON or lower is available, you must have the vehicle adapted to this fuel at a qualified specialist workshop.

- i** E10 fuel contains up to 10% bioethanol. Your vehicle is suitable for use with E10 fuel. You can refuel your vehicle using E10 fuel.

SL 350 BlueEFFICIENCY

- !** Only refuel using premium-grade sulphur-free unleaded petrol with at least 95 RON/85 MON that conforms to European standard EN 228 or an equivalent specification. You could otherwise impair engine output or damage the emission control system.

- i** In some countries, the available petrol may not be sufficiently low in sulphur. This fuel can temporarily produce unpleasant odours, especially on short journeys. As soon as sulphur-free fuel (sulphur content < 10 ppm) is used for refuelling, the odours are reduced.

Additives in petrol

- !** Operating the engine with fuel additives can cause wear in the fuel high-pressure pump and contaminate the entire fuel system. The repair costs are high. This does not include additives for the removal and prevention of residue build-up. Petrol must only be mixed with additives recommended by Mercedes-Benz. More information about recommended additives can be obtained from any Mercedes-Benz Service Centre.

One of the major problems with low-grade fuel is the creation of carbon deposits during the process of burning fuel. Mercedes-Benz recommends that you use fuel brands that have additives.

If you use fuels without these additives for a longer period of time, there may be a build-up of carbon deposits. These will form especially on the inlet valves and in the combustion chamber.

This could lead to engine running problems, e.g.:

- longer engine warm-up phase
- uneven idle
- engine noise
- misfiring
- loss of power

In areas where petrol with the required additives is not available, carbon deposits can

build up. In this case, Mercedes-Benz recommends the use of additives that have been approved for Mercedes-Benz vehicles; see <http://bevo.mercedes-benz.com>.

The quality of the fuel available in some countries may not be sufficient. Residue could build up as a result. In such cases, and in consultation with a Mercedes-Benz Service Centre, the petrol may be mixed with the additive recommended by Mercedes-Benz (part no. A000989254512). You must observe the notes and mixing ratios specified on the container.

Consult a Mercedes-Benz Service Centre to view a list of approved products. Observe the instructions for use in the product description.

Do not mix other fuel additives with fuel. This causes unnecessary costs and could damage the engine.

Fuel consumption information

🌱 Environmental note

CO₂ (carbon dioxide) is the gas which scientists believe to be principally responsible for global warming (the greenhouse effect). Your vehicle's CO₂ emissions are directly related to fuel consumption and therefore depend on:

- efficient use of the fuel by the engine
- driving style
- other non-technical factors, such as environmental influences or road conditions

You can minimise your vehicle's CO₂ emissions by driving carefully and having it serviced regularly.

The vehicle will use more fuel than usual in the following situations:

- at very low outside temperatures
- in urban traffic
- on short journeys
- in mountainous terrain

i Only for certain countries: you can find the current consumption and emission val-

ues of your vehicle in the COC documents (EU CERTIFICATE OF CONFORMITY). These documents are delivered with your vehicle.

The consumption figures were in each case based on the currently applicable version:

- for vehicles up to and including the EURO 4 standard, in accordance with EU Directive 80/1268/EEC
- for vehicles above the EURO 5 standard, in accordance with Regulation (EC) No. 715/2007

Deviations from these values may occur under normal operating conditions.

Engine oil

General notes

When handling engine oil, observe the important safety notes on service products (▷ page 587).

The quality of the engine oil is decisive for the function and service life of an engine. After extensive tests, Mercedes-Benz approves engine oils that correspond to the current technical standard.

Therefore, only Mercedes-Benz approved engine oils may be used in Mercedes-Benz engines.

Further information on tested and approved engine oils can be obtained from any Mercedes-Benz Service Centre. Mercedes-Benz recommends that you have the oil change carried out at a qualified specialist workshop. Mercedes-Benz approval is indicated on the oil container by the inscription "MB Approval" and the corresponding designation, e.g. MB Approval 229.51.

You can call up an overview of approved engine oils on the Internet at: <http://bevo.mercedes-benz.com> by entering the designation, e.g. 229.5.

The table shows which engine oils have been approved for your vehicle.

Model	MB Approval
SL 350	229.3, 229.5
SL 500	229.5
SL 63 AMG	
SL 65 AMG V12	

Use only SAE 0W-40 or SAE 5W-40 engine oils for AMG vehicles.

i If the engine oils listed in the table are not available, you may add the following engine oils until the next oil change:

- vehicles with a petrol engine: MB Approval 229.1 229.3 or ACEA A3
- diesel engines: MB Approval 229.1, 229.3, 229.5 or ACEA C3

Use only SAE 0W-40 or SAE 5W-40 engine oils for AMG vehicles.

This may only be topped up once, and the quantity must not be greater than 1.0 l.

Capacities

The following values refer to an oil change including the oil filter.

Missing values were not available at the time of going to print.

Model	Replacement amount
SL 350	6.5 l
SL 500	
SL 63 AMG	Without external oil cooler: 8.5 l With external oil cooler: 9.5 l
SL 65 AMG V12	Without external oil cooler: 10.0 l With external oil cooler: 11.0 l

Additives

! Do not use any additives with the engine oil. This could damage the engine.

Engine oil viscosity

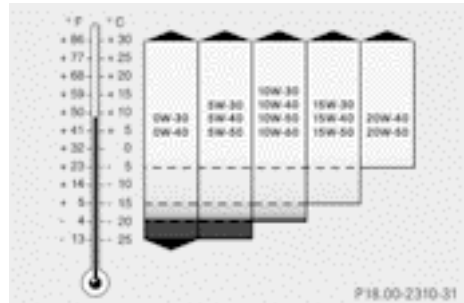

Viscosity describes the flow characteristics of a fluid. If an engine oil has a high viscosity rating, it flows slowly; the lower the viscosity, the faster it flows.

Engine oil selection is based on the respective outside temperatures and in accordance with the SAE classification (viscosity). The table shows you which SAE classifications are to be used. The low-temperature properties of engine oils can be significantly impaired during operation due to, for example, ageing or soot and fuel accretion. It is therefore strongly recommended to observe regular oil changes using an approved engine oil with the appropriate SAE classification.

Brake fluid

⚠ WARNING

The brake fluid continuously absorbs moisture from the air. This results in the boiling point of the brake fluid lowering. If the boiling point of the brake fluid is too low, vapour pockets may form when the brakes are subjected to a heavy load. This would impair braking efficiency. There is a risk of an accident. Have the brake fluid renewed at the prescribed intervals.

When handling brake fluid, observe the important safety notes on service products (▷ page 587).

The brake fluid change intervals can be found in the Service Booklet.

Only use brake fluid approved by Mercedes-Benz according to MB Approval 331.0.

Information about approved brake fluid can be obtained at any qualified specialist workshop or on the Internet at:

<http://bevo.mercedes-benz.com>.

- i** Have the brake fluid regularly replaced at a qualified specialist workshop and the replacement confirmed in the Service Booklet.

Coolant

Important safety notes

WARNING

If antifreeze comes into contact with hot components in the engine compartment, it may ignite. There is a risk of fire and injury.

Let the engine cool down before you top up the antifreeze. Make sure that antifreeze is not spilled next to the filler neck. Thoroughly clean the antifreeze from components before starting the engine.

- !** Only add coolant that has been premixed with the desired antifreeze protection. You could otherwise damage the engine.

Further information on coolants can be found in the Mercedes-Benz Specifications for Service Products, MB Specifications for Service Products 310.1, e.g. on the Internet at <http://bevo.mercedes-benz.com>. Or contact a qualified specialist workshop.

- !** Always use a suitable coolant mixture, even in countries where high temperatures prevail.

Otherwise, the engine cooling system is not sufficiently protected from corrosion and overheating.

- !** The engine cooling system is filled with coolant, which must be renewed after 15 years or after 250,000 kilometres at the latest.

When handling coolant, observe the important safety notes on service products (▷ page 587).

The coolant is a mixture of water and anti-freeze/corrosion inhibitor. It performs the following tasks:

- anti-corrosion protection
- antifreeze protection
- raising the boiling point

If antifreeze/corrosion inhibitor is present in the correct concentration, the boiling point of the coolant during operation will be approximately 130 °C.

The antifreeze/corrosion inhibitor concentration in the engine cooling system should:

- be at least 50%. This will protect the engine cooling system against freezing down to approximately -37 °C.
- not exceed 55% (antifreeze protection down to -45 °C). Heat will otherwise not be dissipated as effectively.

If the vehicle has lost coolant, top it up with equal amounts of water and antifreeze/corrosion inhibitor.

Mercedes-Benz recommends an antifreeze/corrosion inhibitor concentrate in accordance with MB Specifications for Service Products 310.1.

The coolant is checked at every maintenance interval at a qualified specialist workshop.

- i** When the vehicle is first delivered, it is filled with a coolant mixture that ensures adequate antifreeze and corrosion protection.

Windscreen washer system and headlamp cleaning system

Important safety notes

WARNING

Windscreen washer concentrate is highly flammable. If it comes into contact with hot engine components or the exhaust system it could ignite. There is a risk of fire and injury. Make sure that no windscreen washer concentrate is spilled next to the filler neck.

! Only use washer fluid that is suitable for plastic lamp lenses, e.g. MB SummerFit or MB WinterFit. Unsuitable washer fluid could damage the plastic lenses of the headlamps.

! Do not use distilled or de-ionised water in the washer fluid reservoir. Otherwise, the level sensor may be damaged.

! Only the washer fluids SummerFit and WinterFit can be mixed. Otherwise, the spraying nozzles could become blocked.

When handling washer fluid, observe the important safety notes on service products (▷ page 587).

At temperatures above freezing:

- ▶ Fill the washer fluid reservoir with a mixture of water and washer fluid, e.g. MB SummerFit.
- ▶ Mix 1 part MB SummerFit to 100 parts water.

At temperatures below freezing:

- ▶ Fill the washer fluid reservoir with a mixture of water and washer fluid, e.g. MB WinterFit.

Adapt the mixing ratio to the outside temperature.

- Down to -10 °C: mix 1 part MB WinterFit to 2 parts water.
- Down to -20 °C: mix 1 part MB WinterFit to 1 part water.
- Down to -29 °C: mix 2 parts MB WinterFit to 1 part water.

i Add washer fluid concentrate, e.g. MB SummerFit or MB WinterFit, to the washer fluid all year round.

Vehicle data

General notes

Please note that for the specified vehicle data:

- the heights specified may vary as a result of:
 - tyres
 - load
 - condition of the suspension
 - optional equipment
- items of optional equipment increase the unladen weight and reduce the maximum payload. The unladen weight is specified in accordance with EC directive and includes:
 - driver (68 kg)
 - luggage (7 kg)
 - all fluids (fuel tank 90% full)
- vehicle-specific weight information can be found on the vehicle identification plate (▷ page 586).
- only for certain countries: you can find vehicle-specific vehicle data in the COC documents (CERTIFICATE OF CONFORMITY). These documents are delivered with your vehicle.

Dimensions and weights

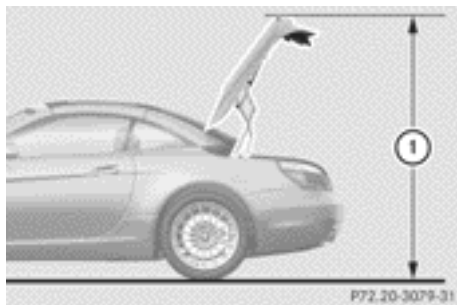

Model	① Opening height
-------	------------------

All models (except AMG vehicles)	1922 mm - 1923 mm
----------------------------------	----------------------

Model	① Opening height
-------	------------------

AMG vehicles	1931 mm - 1945 mm
--------------	----------------------

All models (except AMG vehicles)	
----------------------------------	--

Vehicle length	4612 mm
----------------	---------

Vehicle length when opening/closing the roof	4798 mm
--	---------

Vehicle width including exterior mirrors	2099 mm
--	---------

Vehicle width excluding exterior mirrors	1877 mm
--	---------

Wheelbase	2585 mm
-----------	---------

Maximum boot load	100 kg
-------------------	--------

SL 350	
--------	--

Vehicle height	1314 mm
----------------	---------

Vehicle height when opening/closing the roof	1695 mm
--	---------

Unladen weight	1685 kg
----------------	---------

SL 500	
--------	--

Vehicle height	1315 mm
----------------	---------

Vehicle height when opening/closing the roof	1696 mm
--	---------

Unladen weight	1785 kg
----------------	---------

SL 63 AMG and SL 65 AMG V12	
-----------------------------	--

Vehicle length	4633 mm
----------------	---------

Vehicle length when opening/closing the roof	4858 mm
--	---------

Vehicle width including exterior mirrors	2099 mm
--	---------

Vehicle width excluding exterior mirrors	1877 mm
--	---------

Vehicle height	1300 mm - 1308 mm
----------------	----------------------

Vehicle height, when opening/closing the roof	1688 mm - 1713 mm
---	----------------------

Wheelbase	2585 mm
-----------	---------

Maximum boot load	100 kg
-------------------	--------

SL 63 AMG	
-----------	--

Unladen weight	1845 kg
----------------	---------

SL 65 AMG V12	
---------------	--

Unladen weight	1950 kg
----------------	---------

24 GHz radar sensor system

The 24 GHz radar sensor system requires separate approval for each country. When you are driving in a country in which the radar sensor system is not approved, you must deactivate the system using the on-board computer (▷ page 237).

The current country overview can be obtained from a Mercedes-Benz Service Centre or on the Internet at: <http://www.mercedes-benz.de/betriebsanleitung>.

If you have switched off the radar sensor system using the on-board computer, the following systems will be automatically deactivated:

- DISTRONIC PLUS (▷ page 181)
- BAS PLUS (▷ page 73)
- PRE-SAFE® Brake (▷ page 78)
- Active Blind Spot Assist (▷ page 213)

Vehicles for Australia: when driving in the vicinity of radio telescope facilities, the radar sensor system must be deactivated using the on-board computer (▷ page 237).

Publication details

Internet

Further information about Mercedes-Benz vehicles and about Daimler AG can be found on the following websites:

<http://www.mercedes-benz.com>

<http://www.daimler.com>

Editorial office

You are welcome to forward any queries or suggestions you may have regarding this Owner's Manual to the technical documentation team at the following address:

Daimler AG, HPC: CAC, Customer Service,
70546 Stuttgart, Germany

©Daimler AG: not to be reprinted, translated or otherwise reproduced, in whole or in part, without written permission from Daimler AG.

As at 24.04.2012

Nur für internen Gebrauch / For internal use only



2315843381Z102

Order no. 6515 3139 02 Part no. 231 584 33 81 Z102 Edition NA 2012-03c

Nur für internen Gebrauch / For internal use only