



E-Class

Saloon and Estate
Owner's Manual



Mercedes-Benz

Nur für internen Gebrauch / For internal use only

Symbols

In this manual, you will find the following symbols:

WARNING

Warning notices draw your attention to hazards that may endanger your health or life, or the health or life of others.

Environmental note

Environmental notes provide you with information on environmentally aware actions or disposal.

 Notes on material damage alert you to dangers that could lead to damage to your vehicle.

 These symbols indicate useful instructions or further information that could be helpful to you.

▶ This symbol designates an instruction you must follow.

▶ Several consecutive symbols indicate an instruction with several steps.

(▷ page) This symbol tells you where you can find further information on a topic.

▷▷ This symbol indicates a warning or an instruction that is continued on the next page.

Display This text indicates a message on the multifunction/COMAND display.

Parts of the software in the vehicle are protected by copyright © 2005

The FreeType Project

<http://www.freetype.org>. All rights reserved.

Welcome to the world of Mercedes-Benz

Before you first drive off, read this Owner's Manual carefully and familiarise yourself with your vehicle. For your own safety and a longer vehicle life, follow the instructions and warning notices in this manual. Disregarding them may lead to damage to the vehicle or personal injury.

The equipment or model designation of your vehicle may vary according to:

- Model
- Order
- Country variant
- Availability

The illustrations in this manual show a left-hand-drive vehicle. On right-hand-drive vehicles, the layout of components and controls differs accordingly.

Mercedes-Benz is constantly updating its vehicles to the state of the art.

Mercedes-Benz therefore reserves the right to introduce changes in the following areas:

- Design
- Equipment
- Technical features

The equipment in your vehicle may therefore differ from that shown in the descriptions and illustrations.

The following are integral components of the vehicle:

- Owner's Manual
- Service Booklet
- Equipment-dependent supplements

Keep printed copies of the documents in the vehicle at all times. If you sell the vehicle, always pass the documents on to the new owner.

i You can get to know the important features of your vehicle in the interactive Owner's Manual on the Internet at:

**[http://www.mercedes-benz.de/
betriebsanleitung](http://www.mercedes-benz.de/betriebsanleitung)**

The technical documentation team at Daimler AG wishes you safe and pleasant motoring.



Index	4	At a glance	29
Introduction	23	Safety	41
		Opening and closing	87
		Seats, steering wheel and mirrors ..	113
		Lights and windscreen wipers	135
		Climate control	155
		Driving and parking	175
		On-board computer and displays	267
		Stowing and features	329
		Maintenance and care	363
		Breakdown assistance	381
		Wheels and tyres	403
		Technical data	465

- 1, 2, 3 ...**
- 12 V socket**
see Socket
- 360° camera**
Cleaning 376
Function/notes 241
- 4ETS**
see ETS/4ETS (Electronic Trac-
tion System)
- 4MATIC (permanent four-wheel
drive)** 228
- 4MATIC off-road system** 228
- A**
- ABS (Anti-lock Braking System)**
Display message 291
Function/notes 72
Important safety notes 72
Warning lamp 321
- Activating/deactivating air-recir-
culation mode** 166
- Activating/deactivating cooling
with air dehumidification** 161
- Active Blind Spot Assist**
Activating/deactivating (on-
board computer) 279
Display message 307
Function/notes 254
Towing a trailer 256
- Active Driving Assistance package** . 254
- Active Lane Keeping Assist**
Activating/deactivating (on-
board computer) 279
Display message 306
Function/notes 256
Towing a trailer 259
- Active light function** 141
- Active multicontour seat**
Adjusting (on the seat) 120
- Active Park Assist**
Display message 307
- Active Parking Assist**
Detecting parking spaces 233
Exiting a parking space 235
Function/notes 232
Important safety notes 232
- Parking 234
Towing a trailer 237
- ADAPTIVE BRAKE** 81
- Adaptive Brake Assist**
Function/notes 76
- Adaptive brake lamps** 77
- Adaptive Damping System (ADS)** 225
- Adaptive Highbeam Assist**
Display message 300
Function/notes 142
Switching on/off 143
- Adaptive Highbeam Assist PLUS**
Function/notes 144
Switching on/off 145
- Adaptive Main-beam Assist Plus**
Display messages 300
- AdBlue®**
Display message 303
Filling capacity 474
Important safety notes 473
Service indicator 371
- AdBlue® service indicator** 371
- Additional speedometer** 281
- Additives (engine oil)** 475
- Airbags**
Front airbag (driver, front
passenger) 46
Important safety guidelines 44
Kneebag 46
Pelvis airbag 48
Sidebag 47
Triggering 43
Windowbag 48
- Air-conditioning system**
see Climate control
- Air filter (white display message)** 303
- AIRMATIC**
Display message 304
Function/notes 224
- Air pressure**
see Tyre pressure
- Air vents**
Glove compartment 173
Important safety notes 172
Rear 173
Setting 172

- Setting the centre air vents 173
- Setting the side air vents 173
- Alarm system**
 - see ATA (Anti-Theft Alarm system)
- Ambient lighting**
 - Setting the brightness (on-board computer) 282
 - Setting the colour (on-board computer) 283
- AMG RIDE CONTROL sports suspension** 226
- Anti-glare film** 361
- Anti-lock braking system**
 - see ABS (Anti-lock Braking System)
- Anti-Theft Alarm system**
 - see ATA (Anti-Theft Alarm system)
- Aquaplaning** 204
- Ashtray** 351
- Assistance display (on-board computer)** 277
- Assistance menu (on-board computer)** 277
- ASSYST PLUS**
 - Displaying a service message 370
 - Hiding a service message 370
 - Notes 370
 - Resetting the service interval display 370
 - Service message 370
 - Special service requirements 371
- ATA (anti-theft alarm system)**
 - Activating/deactivating 83
- ATA (Anti-Theft Alarm system)**
 - Function 83
 - Interior motion sensor 85
 - Switching off the alarm 83
 - Tow-away protection 84
- ATTENTION ASSIST**
 - Activating/deactivating 279
 - Display message 304
 - Function/notes 246
- Authorised workshop**
 - see Qualified specialist workshop
- AUTO lights**
 - Display message 300
 - see Lights
- Automatic engine start (ECO start/ stop function)** 182
- Automatic engine switch-off (ECO start/stop function)** 181
- Automatic headlamp mode** 137
- Automatic transmission**
 - Accelerator pedal position 189
 - Automatic drive program 191
 - Changing gear 189
 - DIRECT SELECT lever 187
 - Display message 314
 - Drive program display 187
 - Driving tips 189
 - Emergency running mode 195
 - Engaging drive position 188
 - Engaging neutral 188
 - Engaging reverse gear 188
 - Engaging the park position 187
 - Kickdown 189
 - Manual drive program 191
 - Manual drive program (AMG vehicles) 193
 - Manual drive program (vehicles with Sports package AMG) 193
 - Overview 186
 - Problem (fault) 195
 - Program selector button 190
 - Pulling away 180
 - Selector lever 186
 - Starting the engine 179
 - Steering wheel gearshift paddles ... 191
 - Trailer towing 189
 - Transmission position display 187
 - Transmission position display (DIRECT SELECT lever) 187
 - Transmission positions 189
- Automatic transmission emergency running mode** 195
- Auxiliary heating**
 - Activating/deactivating 168
 - Activating/deactivating (on the centre console) 169
 - Display message 316
 - Important safety notes 168
 - Problem (display message) 172
 - Remote control 169
 - Setting 284
 - Setting the departure time 170

- Auxiliary ventilation**
 Activating/deactivating 168
 Activating/deactivating (on the centre console) 169
 Problem (display message) 172
 Remote control 169
- Axle load, permissible (trailer towing)** 483
- B**
- Bag hook** 339
- Ball coupling**
 Folding in 263
 Folding out 261
- BAS (Brake Assist System)** 73
- BAS PLUS (Brake Assist System PLUS) with Cross-Traffic Assist**
 Function/notes 73
- BAS PLUS Q (Brake Assist System PLUS) with Cross-Traffic Assist**
 Important safety notes 73
- Battery (key)**
 Checking 91
 Important safety notes 91
 Replacing 92
- Battery (vehicle)**
 Charging 391
 Display message 302
 Important safety notes 389
 Jump starting 393
- Belt**
 see Seat belt
- Belt force limiter**
 Activation 54
 Function 54
- Belt tensioner**
 Activation 43
 Function 54
- Blind Spot Assist**
 Activating/deactivating 279
 Display message 307
 Notes/function 250
 Trailer towing 252
 see Active Blind Spot Assist
- BlueTEC (AdBlue®)** 473
- Bluetooth® SAP V3 telephone module**
 see Separate operating instructions
- Bonnet**
 Active bonnet (pedestrian protection) 364
 Closing 366
 Display message 315
 Important safety notes 364
 Opening 366
- Boot**
 Emergency release 103
 Opening/closing (from the outside, HANDS-FREE ACCESS) 100
- Boot lid**
 Display message 315
 Opening dimensions 477
- Boot load (maximum)** 477
- Bottle holders** 349
- Box (boot)** 342
- Brake Assist**
 see BAS (Brake Assist System)
- Brake fluid**
 Display message 294
 Notes 475
- Brake lamps**
 Adaptive 77
 Display message 298
- Brakes**
 ABS 72
 Adaptive Brake Assist 76
 BAS 73
 BAS PLUS with Cross-Traffic Assist . 73
 Brake fluid (notes) 475
 Display message 291
 Driving tips 202
 High-performance brake system 203
 HOLD function 221
 Important safety notes 202
 Parking brake 200
 Warning lamp 320
- Breakdown**
 see Flat tyre
- Bulbs**
 see Replacing bulbs

C

- Calling up a fault**
 - see Display messages
- Car**
 - see Vehicle
- Care**
 - 360° camera 376
 - Automatic car wash 372
 - Carpets 379
 - Display 377
 - Exhaust pipe 377
 - Exterior lighting 375
 - Gear or selector lever 378
 - High-pressure cleaner 373
 - Interior 377
 - Matt paintwork 374
 - Notes 371
 - Paint 374
 - Plastic trim 377
 - Reversing camera 376
 - Roof lining 379
 - Seat belt 378
 - Seat cover 378
 - Sensors 375
 - Steering wheel 378
 - Trim pieces 378
 - Washing by hand 373
 - Wheels 374
 - Windows 374
 - Wiper blades 375
 - Wooden trim 378
- Car key**
 - see Key
- Car wash (care)** 372
- CD player/CD changer(on-board computer)** 275
- Central locking**
 - Automatic locking (on-board computer) 284
 - Locking/unlocking (key) 89
- Centre console**
 - Lower section 37
 - Lower section (AMG vehicles) 38
 - Upper section 36
- Changing bulbs**
 - Main-beam headlamps 148
 - Turn signals (front) 148
- Child-proof locks**
 - Important safety notes 70
 - Rear doors 71
- Children**
 - Fastening seat belts 62
 - In the vehicle 55
 - Restraint systems 55
- Child seat**
 - Automatic recognition 57
 - Integrated 61
 - Integrated, ICS padded play table 63
 - Integrated, side head restraints 64
 - Integrated, storing 65
 - ISOFIX 59
 - On the front-passenger seat 57
 - Problem (malfunction) 70
 - Recommendations 67
 - Suitable positions 65
 - Top Tether 59
- Cigarette lighter** 352
- Cleaning**
 - Mirror turn signal 375
 - Trailer tow hitch 377
- Climate control**
 - Auxiliary heating/ventilation 168
 - Controlling automatically 162
 - Convenience opening/closing (air-recirculation mode) 166
 - Cooling with air dehumidification . . 161
 - Demisting the windows 165
 - Demisting the windscreen 164
 - Important safety notes 156
 - Indicator lamp 162
 - Information about using THERMATIC automatic climate control 157
 - Information on using THERMOTRONIC automatic climate control 160
 - Overview of systems 156
 - Problems with cooling with air dehumidification 162
 - Problem with the rear window heating 166
 - Rear control panel 159
 - Setting the air distribution 163
 - Setting the airflow 164
 - Setting the air vents 172

- Setting the climate mode 162
- Setting the temperature 163
- Setting the temperature,
THERMATIC 163
- Setting the temperature,
THERMOTRONIC 163
- Switching air-recirculation mode
on/off 166
- Switching on/off 160
- Switching residual heat on/off 167
- Switching the rear window heat-
ing on/off 165
- Switching the ZONE function on/
off 164
- THERMATIC automatic climate
control (2-zone) 157
- THERMOTRONIC (3-zone) auto-
matic climate control 159
- Coat hooks** 342
- Cockpit**
- Overview 30
- see Instrument cluster
- Collapsible emergency spare
wheel**
- see Emergency spare wheel
- COLLISION PREVENTION ASSIST**
- Activating/deactivating the dis-
tance warning function 279
- Display message 295
- Operation/notes 75
- COMAND display**
- Cleaning 377
- COMAND Online**
- see separate operating instructions
- Combination switch** 139
- Combined luggage cover and net** 341
- Consumption statistics (on-board
computer)** 271
- Convenience box** 342
- Convenience closing feature** 105
- Convenience opening/closing (air-
recirculation mode)** 166
- Convenience opening feature** 105
- Coolant (engine)**
- Checking the level 368
- Display message 301
- Important safety notes 475
- Temperature (on-board computer) . 287
- Temperature gauge 268
- Warning lamp 325
- Cooling**
- see Climate control
- Copyright** 27
- Cornering light function**
- Display message 297
- Function/notes 141
- Crash-responsive emergency light-
ing** 147
- Cruise control**
- Activation conditions 206
- Cruise control lever 205
- Deactivating 207
- Display message 310
- Driving system 205
- Important safety notes 205
- LIM indicator lamp 205
- Selecting 206
- Setting a speed 207
- Storing and maintaining current
 speed 206
- Cup holder**
- Centre console 348
- Folding bench seat 349
- Important safety notes 348
- Rear compartment 349

D

- Dashboard**
- see Instrument cluster
- Dashboard lighting**
- see Instrument cluster lighting
- Data**
- see Technical data
- Daytime driving lights**
- Display message 299
- Function/notes 137
- Switching on/off (on-board com-
puter) 281
- Declarations of conformity** 25
- Delayed switch-off**
- Exterior lighting (on-board com-
puter) 283
- Interior lighting 283
- Diagnostics connection** 25
- Diesel** 472

Digital speedometer	272	Control panel	40
Dipped-beam headlamps		Display message	315
Display message	297	Emergency locking	97
Setting for driving abroad (sym-		Emergency unlocking	96
metrical)	136	Important safety notes	94
Setting for driving on the right/left	282	Opening (from the inside)	95
Switching on/off	137	Drive program	
DIRECT SELECT lever		Automatic	191
see Automatic transmission		Display	187
Display message		Display (DIRECT SELECT lever)	187
ASSYST PLUS	370	Manual	191
General information	290	Manual (AMG vehicles)	193
Hiding (on-board computer)	290	Manual (vehicles with Sports	
KEYLESS-GO	317	package AMG)	193
Display messages		Drive program selector	190
Calling up (on-board computer)	290	Driver's door	
Driving systems	304	see Door	
Engine	301	Drive system	
Key	317	Active Blind Spot Assist	254
Lights	297	Driving abroad	
Safety systems	291	Service24h	371
Tyres	312	Symmetrical dipped beam	136
Vehicle	314	Driving on flooded roads	204
Distance recorder		Driving safety system	
see Trip meter		Adaptive Brake Assist	76
Distance warning function		BAS PLUS with Cross-Traffic Assist .	73
Activating/deactivating	279	COLLISION PREVENTION ASSIST	75
Function/notes	75	Distance warning function	75
Distance warning signal (warning		Electronic Brake-force Distribution ..	80
lamp)	327	ESP® (Electronic Stability Program) .	77
DISTRONIC PLUS		ETS/4ETS (Electronic Traction	
Activating	213	System)	77
Activation conditions	213	Important safety guidelines	72
Deactivating	218	Driving safety systems	
Display message	308	ABS (Anti-lock Braking System)	72
Displays in the multifunction display		ADAPTIVE BRAKE	81
.....	217	Adaptive brake lamps	77
Function/notes	211	BAS (Brake Assist System)	73
Important safety notes	211	Overview	71
Selecting	213	PRE-SAFE® Brake	81
Setting the specified minimum		Steering assistant STEER CON-	
distance	216	TROL	83
Warning lamp	327	Driving system	
Door		360° camera	241
Automatic locking (on-board com-		Active Lane Keeping Assist	256
puter)	284	Active Parking Assist	232
Automatic locking (switch)	96		
Central locking/unlocking (key)	89		

Driving systems

Active Driving Assistance package	254
AIRMATIC	224
AMG RIDE CONTROL sports suspension	226
ATTENTION ASSIST	246
Blind Spot Assist	250
Cruise control	205
Display message	304
Distronic Plus	211
DISTRONIC PLUS with Steering Assist	220
HOLD function	221
Lane Keeping Assist	252
Lane package	250
PARKTRONIC	228
RACE START (AMG vehicles)	223
Reversing camera	237
SPEEDTRONIC	208
Traffic Sign Assist	247

Driving tips

AMG ceramic brakes	203
Aquaplaning	204
Automatic transmission	189
Brakes	202
Downhill gradient	202
Driving abroad	136
Driving in winter	204
Driving on flooded roads	204
Driving on wet roads	204
General	201
Icy road surfaces	204
Limited braking efficiency on salted roads	203
New brake pads/linings	203
Running-in tips	176
Snow chains	407
Symmetrical dipped beam	136
Towing a trailer	260
Wet road surface	203

DVD audio

Operating (on-board computer)	275
-------------------------------------	-----

DVD video

Operating (on-board computer)	275
-------------------------------------	-----

E**EASY-ENTRY feature**

Activating/deactivating	285
Function/notes	128

EASY-EXIT feature

Crash-responsive	129
Function/notes	128
Switching on/off	285

EASY-PACK convenience box 342**EASY-PACK folding floor**

Important safety notes	346
------------------------------	-----

EASY-PACK folding luggage-compartment floor

Opening and closing	346
---------------------------	-----

EASY-PACK loading sill protector 347**EASY-PACK load-securing kit**

Components and storage	344
Inserting the brackets into the loading rail	344

EASY-PACK luggage compartment**management system** 344**EBD (electronic brake force distribution)**

Display message	293
Function/notes	80

ECO display

Function/notes	201
On-board computer	272

ECO start/stop function

Automatic engine start	182
Automatic engine switch-off	181
Deactivating/activating	183
General information	181
Important safety notes	181
Introduction	181

Electrical fuses

see Fuses

Electromagnetic compatibility

Declaration of conformity	25
---------------------------------	----

Electronic Stability Program

see ESP® (Electronic Stability Program)

Emergency key

Unlocking the driver's door	96
-----------------------------------	----

Emergency key element

Function/notes	90
Locking vehicle	97

- Emergency release**
 Driver's door 96
 Fuel filler flap 197
- Emergency spare wheel**
 Important safety notes 459
 Inflating the collapsible spare wheel 461
 Points to remember 459
 Removing 460
 Storage location 460
 Stowing 461
 Technical data 463
- Emergency unlocking**
 Tailgate 103
 Vehicle 96
- Engine**
 Display message 301
 ECO start/stop function 181
 Engine number 469
 Jump-starting 393
 Running irregularly 184
 Starting problems 184
 Starting the engine with the key 179
 Starting with KEYLESS GO 179
 Stopping 199
 Tow-starting (vehicle) 399
 Warning lamp (engine diagnostics) 325
- Engine electronics**
 Notes 466
 Problem (fault) 184
- Engine jump starting**
 see Jump starting (engine)
- Engine oil**
 Additives 475
 Checking the oil level 366
 Checking the oil level using the dipstick 367
 Display message 302
 Filling capacity 474
 Notes about oil grades 474
 Notes on oil level/consumption 366
 Temperature (on-board computer) . 287
 Topping up 367
 Viscosity 475
- Environmental protection**
 Returning an end-of-life vehicle 23
- ESP® (Electronic Stability Program)**
 AMG menu (on-board computer) ... 287
 Deactivating/activating (AMG vehicles) 79
 Deactivating/activating (except AMG vehicles) 278
 Deactivating/activating (notes; except AMG vehicles) 78
 Display message 291
 ETS/4ETS 77
 Function/notes 77
 General notes 77
 Important safety guidelines 77
 Trailer stabilisation 80
 Warning lamp 322
- ETS/4ETS (Electronic Traction System)** 77
- Exhaust pipe (cleaning instructions)** 377
- Exterior lighting**
 Settings options 136
 see Lights
- Exterior mirrors**
 Adjusting 129
 Anti-dazzle mode (automatic) 131
 Folding in/out (automatically) 130
 Folding in/out (electrically) 130
 Folding in when locking (on-board computer) 286
 Out of position (troubleshooting) ... 130
 Parking position 131
 Resetting 130
 Storing settings (memory function) 132

F

- Fault message**
 see Display messages
- Filler cap**
 see Fuel filler flap
- Fire extinguisher** 383
- First-aid kit** 382
- Fitting a wheel**
 Removing a wheel 417
- Fitting wheels**
 Fitting a wheel 417
 Lowering the vehicle 418

Raising the vehicle	415	Fuses	
Securing the vehicle against rolling away	415	Allocation chart	400
Flat tyre		Before changing	400
MOExtended tyres	385	Fuse box in the boot	401
Preparing the vehicle	385	Fuse box in the engine compartment	400
TIREFIT kit	387	Fuse box in the luggage compartment	401
Floormat	360	Important safety notes	399
Foglamps			
Extended range	142		
Folding bench seat (luggage compartment)	121		
Frequencies		G	
Garage door opener	357	Garage door opener	
Mobile phone	466	Clearing the memory	357
Two-way radio	466	Frequencies	357
Fuel		Important safety notes	355
Additives	471	Opening/closing the garage door ..	357
Consumption information	472	Programming (button in the rear-view mirror)	355
Consumption statistics	271	Gear indicator (on-board computer)	287
Displaying the current consumption	272	Gearshift program	
Displaying the range	272	SETUP (on-board computer)	287
E10	470	Genuine Mercedes-Benz parts	23
Fuel gauge	32	Glove compartment	331
Grade (petrol)	470		
Important safety notes	469	H	
Notes for AMG vehicles	471	Handbrake	
Problem (malfunction)	198	see Parking brake	
Quality (diesel)	472	HANDS-FREE ACCESS	100
Refuelling	195	Hazard warning lamps	140
Tank content/reserve fuel	470	Headbag	
Fuel filler flap		Display message	297
Emergency release	197	Headlamps	
Opening/closing	196	Misting up	145
Fuel filter (white display message) .	303	see Automatic headlamp mode	
Fuel level		Head restraints	
Calling up the range (on-board computer)	272	Adjusting	117
Gauge	32	Adjusting (electrically)	118
Fuel reserve		Adjusting (manually)	117
see Fuel		Adjusting (rear)	118
Fuel tank		Fitting/removing (rear)	119
Capacity	470	Luxury	118
Problem (malfunction)	198	Heating	
Fuse allocation chart (vehicle tool kit)	383	see Climate control	
		High-pressure cleaners	373
		Hill start assist	180

- HOLD function**
- Activating 222
 - Deactivating 222
 - Display message 305
 - Function/notes 221
- I**
- ICS padded play table** 63
- Ignition lock**
- see Key positions
- Immobiliser** 83
- In-car hotspot**
- see Separate operating instructions
- Indicator and warning lamps**
- Coolant 325
 - DISTRONIC PLUS 327
 - Engine diagnostics 325
 - SPORT handling mode 323
- Indicator lamps**
- Display message 298
 - see Warning and indicator lamps
- Indicators**
- see Turn signals
- Insect protection on the radiator** 366
- Inspection**
- see ASSYST PLUS
- Instrument cluster**
- Overview 32
 - Settings 280
 - Warning and indicator lamps 34
- Instrument cluster lighting** 281
- Integrated child seat**
- ICS padded play table 63
 - Important safety guidelines 61
 - Side head restraints 64
 - Storing, ICS padded play table and side head restraints 65
- Intelligent Light System**
- Activating/deactivating 282
 - Display message 299
 - Overview 141
 - Setting the dipped-beam headlamps for driving on the right/left . 282
- Interior lighting** 146
- Automatic control system 146
 - Delayed switch-off (on-board computer) 283
 - Emergency lighting 147
 - Manual control 147
 - Overview 146
 - Reading lamp 146
 - Setting brightness for display/switches (on-board computer) 281
 - Setting the ambient lighting brightness (on-board computer) 282
 - Setting the ambient lighting colour (on-board computer) 283
- Interior motion sensor** 85
- ISOFIX child seat securing system** 59
- J**
- Jack**
- Storage location 383
 - Using 415
- Jump starting (engine)** 393
- K**
- Key**
- Changing the battery 92
 - Checking the battery 91
 - Convenience closing feature 105
 - Convenience opening feature 105
 - Display message 317
 - Door central locking/unlocking 89
 - Emergency key element 90
 - Important safety notes 88
 - Loss 93
 - Modifying the programming 90
 - Overview 88
 - Positions (ignition lock) 177
 - Problem (malfunction) 93
 - Starting the engine 179
- KEYLESS-GO**
- Convenience closing 106
 - Display message 317
 - Locking 89
 - Start/Stop button 177
 - Starting the engine 179
 - Unlocking 89
- Key positions**
- Key 177
 - KEYLESS GO 177

- Kickdown**
 Driving tips 189
 Manual drive program 194
- Kneebag** 46
- L**
- Lamps**
 see Warning and indicator lamps
- Lane Keeping Assist**
 Activating/deactivating 279
 Display message 306
 Function/information 252
- Lane package** 250
- Lap time (RACETIMER)** 287
- Lashing eyelets** 339
- Licence plate lamp (display message)** 299
- Lights**
 Activating/deactivating the Intelligent Light System 282
 Activating/deactivating the interior lighting delayed switch-off 283
 Active light function 141
 Adaptive Highbeam Assist PLUS 144
 Automatic headlamp mode 137
 Cornering light function 141
 Dipped-beam headlamps 137
 Driving abroad 136
 Foglamps (extended range) 142
 Hazard warning lamps 140
 Headlamp flasher 140
 Light switch 136
 Main-beam headlamps 140
 Motorway mode 142
 Parking lamps 139
 Rear foglamp 138
 Setting brightness for display/switches (on-board computer) 281
 Setting the ambient lighting brightness (on-board computer) 282
 Setting the ambient lighting colour (on-board computer) 283
 Side lamps 138
 Switching the daytime driving lights on/off (on-board computer) . 281
 Switching the exterior lighting delayed switch-off on/off (on-board computer) 283
 Switching the surround lighting on/off (on-board computer) 283
 Turn signals 139
 see Interior lighting
 see Replacing bulbs
- Light sensor (display message)** 300
- LIM indicator lamp**
 Cruise control 205
 DISTRONIC PLUS 212
 Variable SPEEDTRONIC 208
- Limiting the speed**
 see SPEEDTRONIC
- Loading guidelines** 330
- Loading sill protector** 347
- Locking**
 see Central locking
- Locking (doors)**
 Automatic 96
 Emergency locking 97
 From inside (central locking button) 95
- Locking centrally**
 see Central locking
- Locking verification signal (on-board computer)** 284
- Luggage compartment cover** 340
- Luggage compartment enlargement** 337
- Luggage compartment floor** 346
- Luggage holder (EASY-PACK load-securing kit)** 344
- Lumbar support**
 Adjusting the 4-way lumbar support 121
- Luxury head restraint** 118
- M**
- M+S tyres** 406
- Main-beam headlamps**
 Adaptive Highbeam Assist PLUS 144
 Changing bulbs 148
 Display message 298
 Switching on/off 140
- Maintenance**
 see ASSYST PLUS

- Manual transmission**
- Engaging reverse gear 186
 - Gear lever 185
 - Pulling away 180
 - Shifting to neutral 186
 - Shift recommendation 186
 - Starting the engine 179
- Message function (PULSE)** 121
- Matt finish (cleaning instructions)** .. 374
- Memory card (audio)** 275
- Memory function** 132
- Mercedes-Benz Service Centre**
see Qualified specialist workshop
- Message memory (on-board computer)** 290
- Messages**
see Display messages
- Mirror**
see Vanity mirror (in sun visor)
- Mirrors**
see Exterior mirrors
see Rear-view mirror
- Mobile phone**
- Frequencies 466
 - Installation 466
 - Menu (on-board computer) 276
 - Notes/placing in the bracket 353
 - Transmission output (maximum) 466
- Mobile telephone**
Pre-installed bracket 355
- Modifying the programming (key)** 90
- MOExtended tyres** 385
- Motorway mode** 142
- MP3**
- Operating 275
 - see Separate operating instructions
- Multicontour seat**
Adjusting (on the seat) 120
- Multifunction display**
- Function/notes 270
 - Permanent display 281
- Multifunction steering wheel**
- Operating the on-board computer . 269
 - Overview 35
- N**
- Navigation**
- Menu (on-board computer) 273
- NECK-PRO head restraints**
- Operation 49
 - Resetting after being triggered 49
- NECK-PRO luxury head restraints**
- Operation 49
 - Resetting after being triggered 49
- Notes on running in a new vehicle** .. 176
- O**
- Occupant safety**
- Children in the vehicle 55
 - Important safety notes 42
- Odometer**
see Total distance recorder
see Trip meter
- Oil**
see Engine oil
- On-board computer**
- AMG menu 287
 - Assistance menu 277
 - Audio menu 274
 - Convenience submenu 285
 - Displaying a service message 370
 - Display messages 290
 - DISTRONIC PLUS 217
 - Factory setting submenu 286
 - Heating submenu 284
 - Important safety notes 268
 - Instrument cluster submenu 280
 - Light submenu 281
 - Menu overview 271
 - Message memory 290
 - Navigation menu 273
 - Operating the TV 275
 - Operating video DVD 275
 - Operation 269
 - RACETIMER 287
 - Service menu 280
 - Settings menu 280
 - Standard display 271
 - Telephone menu 276
 - Trip menu 271
 - Vehicle submenu 284

- Operating instructions**
 Vehicle equipment 24
- Operating safety**
 Declaration of conformity 25
 Important safety note 24
- Operating system**
 see On-board computer
- Outside temperature display** 269
- Overhead control panel** 39
- Override feature**
 Rear side windows 71
- P**
- Paint code** 468
- Paintwork (cleaning instructions)** ... 374
- Panic alarm** 42
- Panorama sliding sunroof**
 Important safety information 107
 Opening/closing 109
 Opening/closing the roller sun-blind 110
 Problem (malfunction) 112
 Rain closing feature 109
 Resetting 111
- Parking** 199
 Important safety notes 199
 Parking brake 200
 Position of exterior mirror, front-passenger side 131
 Reversing camera 237
 see PARKTRONIC
- Parking aid**
 Active Parking Assist 232
 see Exterior mirrors
 see PARKTRONIC
- Parking assistance**
 see PARKTRONIC
- Parking brake**
 Display message 293
 Notes/function 200
 Warning lamp 320
- Parking lamps**
 Display message 299
 Switching on/off 139
- PARKTRONIC**
 Deactivating/activating 230
 Driving system 228
 Function/notes 228
 Important safety notes 228
 Problem (fault) 232
 Sensor range 229
 Trailer towing 231
 Warning display 230
- PASS AIRBAG OFF**
 see PASSENGER AIRBAG OFF
- PASSENGER AIRBAG OFF**
 Indicator lamp 57
 Problem (malfunction) 70
- Petrol** 470
- Plastic hooks** 339
- Plastic trim (cleaning instructions)** . 377
- Power windows**
 see Side windows
- PRE-SAFE® (preventive occupant safety system)**
 Display message 294
 Operation 50
- PRE-SAFE® Brake**
 Activating/deactivating 278
 Display message 295
 Function/notes 81
 Important safety notes 81
 Warning lamp 327
- Program selector button** 190
- Protection of the environment**
 General notes 23
- Pulling away**
 Automatic transmission 180
 Manual transmission 180
- Q**
- Qualified specialist workshop** 26
- R**
- RACE START (AMG vehicles)** 223
- RACETIMER (on-board computer)** ... 287
- Radiator cover** 366
- Radio**
 Selecting a station 274
 see separate operating instructions
- Radio-based vehicle components**
 Declaration of conformity 25

Rain closing feature	
Panorama sliding sunroof	109
Sliding sunroof	108
Reading lamp	146
Rear bench seat	
Folding the backrest forwards/ back	336
Rear compartment	
Setting the airflow	164
Setting the air vents	173
Setting the temperature	163
Rear-compartment seat belt status indicator	54
Rear foglamp	
Display message	299
Switching on/off	138
Rear seat	
Display message	316
Rear Seat Entertainment System	
see Separate operating instructions	
Rear-view mirror	
Anti-dazzle mode (automatic)	131
Dipping (manual)	129
Rear window blind	351
Rear window heating	
Problem (fault)	166
Switching on/off	165
Rear window wiper	
Replacing the wiper blade	151
Switching on/off	150
Refuelling	
Fuel gauge	32
Important safety notes	195
Notes for AMG vehicles	471
Refuelling process	196
see Fuel	
Remote control	
Auxiliary heating/ventilation	169
Changing the batteries (auxiliary heating)	170
Garage door opener	355
Programming (garage door opener)	355
Replacing bulbs	
Important safety notes	147
Overview of bulb types	148
Replacing the battery (auxiliary heating remote control)	170
Reserve (fuel tank)	
see Fuel	
Reserve fuel	
Display message	303
Warning lamp	325
Residual heat (climate control)	167
Restraint system	
see SRS (Supplemental Restraint System)	
Rev counter	268
Reverse gear	
Engaging (automatic transmission)	186
Engaging (manual transmission)	186
Reversing camera	
Cleaning instructions	376
Function/notes	237
Switching on/off	238
Reversing feature	
Panorama sliding sunroof	108
Roller sunblinds	110
Side windows	104
Sliding sunroof	108
Reversing function	
Boot lid/tailgate	98
Reversing lamp (display message) ..	299
Roller sunblind	
Panorama sliding sunroof	110
Rear window	351
Roof carrier	347
Roof lining and carpets (cleaning instructions)	379
Roof load (maximum)	477
S	
Safety	
Children in the vehicle	55
Child restraint systems	55
Safety net	
Attaching	342
Important safety information	342
Safety system	
see Driving safety system	
Seat	
Adjusting the active multicontour seat	120
Adjusting the multicontour seat	120

- Folding the backrest (rear compartment) forwards/back 337
 Massage function 121
- Seat belt**
- Adjusting the driver's and front-passenger seat belt 52
 - Adjusting the height 52
 - Belt force limiter 54
 - Belt tensioner 54
 - Centre rear-compartment seat 53
 - Cleaning 378
 - Display message 295
 - Fastening 52
 - Important safety guidelines 51
 - Rear seat belt status indicator 54
 - Releasing 53
 - Switching belt adjustment on/off (on-board computer) 286
 - Warning lamp 319
 - Warning lamp (function) 53
- Seats**
- Adjusting (electrically) 116
 - Adjusting (manually and electrically) 116
 - Adjusting the 4-way lumbar support 121
 - Adjusting the head restraint 117
 - Cleaning the cover 378
 - Correct driver's seat position 114
 - Important safety notes 115
 - Overview 115
 - Seat heating problem 125
 - Seat ventilation problem 126
 - Storing settings (memory function) 132
 - Switching seat heating on/off 123
 - Switching the seat ventilation on/off 125
- Selector lever**
- Cleaning 378
- Sensors (cleaning instructions)** 375
- Service**
- see ASSYST PLUS
- Service menu (on-board computer)** . 280
- Service products**
- AdBlue® special additives 473
 - Brake fluid 475
 - Coolant (engine) 475
 - Engine oil 474
 - Fuel 469
 - Important safety notes 469
 - Washer fluid 476
- Settings**
- Factory (on-board computer) 286
 - On-board computer 280
- Setting the air distribution** 163
- Setting the airflow** 164
- SETUP (on-board computer)** 287
- Shifting to neutral (manual transmission)** 186
- Sidebag** 47
- Side lamps**
- Switching on/off 138
- Side marker lamp Display message** 299
- Side windows**
- Convenience closing 105
 - Convenience opening 105
 - Important safety notes 104
 - Opening/closing 104
 - Problem (malfunction) 107
 - resetting 106
- Skibag** 334
- Sliding sunroof**
- Important safety information 107
 - Opening/closing 108
 - Problem (malfunction) 112
 - Rain closing feature 108
 - Resetting 109
 - see Panorama sliding sunroof
- Snow chains** 407
- Socket**
- Centre console 353
 - Luggage compartment 353
 - Rear compartment 353
- Sockets**
- General notes 353
- Spare wheel**
- Storing 461
- Specialist workshop** 26
- Spectacles compartment** 331
- Speed, controlling**
- see Cruise control
- Speedometer**
- Activating/deactivating the additional speedometer 281
 - Digital 272

- In the Instrument cluster 32
 - Segments 269
 - Selecting the unit of measurement 280
see Instrument cluster
 - SPEEDTRONIC**
 - Deactivating variable 210
 - Display message 310
 - Function/notes 208
 - Important safety notes 208
 - LIM indicator lamp 208
 - Permanent 211
 - Selecting 209
 - Storing the current speed 209
 - Variable 208
 - SPORT handling mode**
 - Activating/deactivating (AMG vehicles) 79
 - Warning lamp 323
 - SRS (Supplemental Restraint System)**
 - Display message 296
 - Introduction 43
 - Warning lamp 324
 - Warning lamp (function) 43
 - Start/stop function**
see ECO start/stop function
 - Starting (engine)** 178
 - STEER CONTROL** 83
 - Steering (display message)** 317
 - Steering Assist (DISTRONIC PLUS)**
 - Activating/deactivating 279
 - Display message 310
 - Steering wheel**
 - Adjusting (electrically) 127
 - Adjusting (manually) 126
 - Button overview 35
 - Buttons (on-board computer) 269
 - Cleaning 378
 - Gearshift paddles 191
 - Important safety notes 126
 - Steering wheel heating 127
 - Storing settings (memory function) 132
 - Steering wheel gearshift paddles** 191
 - Steering wheel heating**
 - Problem (malfunction) 128
 - Switching on/off 127
 - Stopwatch (RACETIMER)** 287
 - Stowage areas** 330
 - Stowage compartment**
 - Spectacles compartment 331
 - Stowage compartments**
 - Armrest (under) 332
 - Centre console 331
 - Cup holder 348
 - Glove compartment 331
 - Important safety information 330
 - Rear 333
 - Under driver's seat/front-passenger seat 333
 - Stowage net** 334
 - Stowage space**
 - Stowage net 334
 - Stowage well beneath the boot floor** 345
 - Summer tyres** 406
 - Sun blind**
 - Rear side windows 351
 - Sun visor** 350
 - Supplemental Restraint System**
see SRS (Supplemental Restraint System)
 - Surround lighting (on-board computer)** 283
 - Suspension tuning**
 - AIRMATIC 225
 - AMG RIDE CONTROL sports suspension 226
 - SETUP (on-board computer) 287
 - Switching off the alarm (ATA)** 83
- T**
- Tailgate**
 - Display message 315
 - Emergency unlocking 103
 - Important safety notes 97
 - Limiting the opening angle 102
 - Opening/closing (automatically from inside) 101
 - Opening/closing (automatically from outside) 99
 - Opening/closing (from outside) 98
 - Opening dimensions 477
 - Tail lamps**
 - Display message 298

- Tank**
see Fuel tank
- Technical data**
Capacities 469
Emergency spare wheel 463
Information 466
Trailer loads 481
Tyres/wheels 419
Vehicle data 477
- Telephone**
Accepting a call 276
Display message 317
Menu (on-board computer) 276
Number from the phone book 277
Redialling 277
Rejecting/ending a call 276
Telephone compartment 332
- Telescopic rod (Easy-Pack fix kit)** 345
- Temperature**
Coolant 268
Coolant (on-board computer) 287
Engine oil (on-board computer) 287
Outside temperature 269
Setting (climate control) 163
- TEMPOMAT**
Function/notes 205
- Theft-deterrent system**
ATA (Anti-Theft Alarm system) 83
Immobiliser 83
- Through-loading** 336
- Through-loading feature** 336
- Timing (RACETIMER)** 287
- TIREFIT kit** 387
- Top Tether** 59
- Total distance recorder** 271
- Tow-away protection** 84
- Towing**
Important safety notes 396
With the rear axle raised 398
- Towing a trailer**
Active Blind Spot Assist 256
Active Lane Keeping Assist 259
Active Parking Assist 237
Axle load, permissible 483
Bulb failure indicator for LED lamps 265
ESP® (Electronic Stability Program) . 80
- Towing away**
Fitting the towing eye 397
Removing the towing eye 397
With both axles on the ground 398
- Tow-starting**
Emergency engine starting 399
Important safety notes 396
Removing the towing eye 397
- Traffic Sign Assist**
Activating/deactivating the warn-
ing function 278
Display message 305
Function/notes 247
Important safety notes 248
Instrument cluster display 249
- Trailer**
Display message 316
- Trailer coupling**
see Towing a trailer
- Trailer towing**
7-pin connector 265
Blind Spot Assist 252
Cleaning the trailer tow hitch 377
Coupling up a trailer 263
Decoupling a trailer 263
Driving tips 260
Folding in the ball coupling 263
Folding out the ball coupling 261
Important safety notes 259
Lights display message 297
Mounting dimensions 480
Parktronic 231
Power supply 265
Trailer loads 481
- Transmission**
see Automatic transmission
see Manual transmission
- Transmission position display** 187
- Transmission position display (DIRECT SELECT lever)** 187
- Transporting the vehicle** 398
- Trim pieces (cleaning instructions)** . 378
- Trip computer (on-board computer)** 271
- Trip meter**
Calling up 271
Resetting (on-board computer) 272

- Turn signals**
 Changing bulbs (front) 148
 Switching on/off 139
- TV**
 Operating (on-board computer) 275
 see Separate operating instructions
- Two-way radio**
 Frequencies 466
 Installation 466
 Transmission output (maximum) 466
- Type identification plate**
 see Vehicle identification plate
- Tyre pressure**
 Calling up (on-board computer) 410
 Display message 312
 Important safety notes 410
 Not reached (TIREFIT) 388
 Reached (TIREFIT) 388
 Recommended 407
- Tyre pressure loss warning**
 General notes 409
 Important safety notes 409
 Restarting 410
- Tyre pressure monitor**
 Checking the tyre pressure elec-
 tronically 411
 Function/notes 410
 General notes 410
 Important safety notes 411
 Restarting 412
 Warning lamp 328
 Warning message 412
- Tyres**
 Changing a wheel 413
 Checking 405
 Direction of rotation 414
 Display message 312
 Important safety notes 404
 MOExtended tyres 406
 Replacing 413
 Service life 405
 Storing 414
 Tyre size (data) 419
 Tyre tread 405
 see Flat tyre
- U**
- Unlocking**
 Emergency unlocking 96
 From inside the vehicle (central
 unlocking button) 95
- V**
- Vanity mirror (in sun visor) 350**
- Variable SPEEDTRONIC**
 see SPEEDTRONIC
- Vehicle**
 Correct use 26
 Data acquisition 26
 Display message 314
 Electronics 466
 Equipment 24
 Implied warranty 26
 Individual settings 280
 Leaving parked up 201
 Locking (in an emergency) 97
 Locking (key) 89
 Lowering 418
 Pulling away 180
 Raising 415
 Registration 26
 Securing from rolling away 415
 Towing away 396
 Tow-starting 396
 Transporting 398
 Unlocking (in an emergency) 96
 Unlocking (key) 89
 Vehicle data 477
- Vehicle data 477**
- Vehicle dimensions 477**
- Vehicle emergency locking 97**
- Vehicle identification number**
 see VIN
- Vehicle identification plate 468**
- Vehicle level**
 AIRMATIC 224
- Vehicle level (display message) 304**
- Vehicle tool kit 383**
- Vehicle weights 477**
- Video**
 Operating the DVD 275
- VIN 468**

W	
Warning and indicator lamps	
ABS	321
Brakes	320
Distance warning signal	327
ESP®	322
ESP® OFF	323
Fuel tank	325
LIM (cruise control)	205
LIM (DISTRONIC PLUS)	212
LIM (variable SPEEDTRONIC)	208
Overview	34
PASSENGER AIRBAG OFF	57
Reserve fuel	325
Seat belt	319
SRS	324
Tyre pressure monitor	328
Warning triangle	382
Washer fluid	
Display message	317
Wheel bolt tightening torque	418
Wheel chock	415
Wheels	
Changing/replacing	413
Changing a wheel	413
Checking	405
Cleaning	374
Cleaning (warning)	414
Emergency spare wheel	459
Fitting a new wheel	417
Fitting a wheel	414
Important safety notes	404
Removing a wheel	417
Storing	414
Tightening torque	418
Wheel size/tyre size	419
Windowbag	
Operation	48
Windows	
Cleaning	374
see Side windows	
Windscreen	
Demisting	164
Windscreen washer fluid	
see Windscreen washer system	
Windscreen washer system	
Notes	476
Topping up	369
Windscreen wipers	
Problem (malfunction)	153
Rear window wiper	150
Replacing the wiper blades	150
Switching on/off	149
Winter operation	
Important safety notes	406
Radiator cover	366
Slippery road surfaces	204
Snow chains	407
Winter tyres	
Limiting the speed (on-board computer)	284
M+S tyres	406
Wiper blades	
Cleaning	375
Important safety notes	150
Replacing (on the rear window)	151
Replacing (windscreen)	151
Wooden trim (cleaning instructions)	378
Workshop	
see Qualified specialist workshop	
Z	
ZONE function	
Switching on/off	164

Protection of the environment

General notes

Environmental note

Daimler's declared policy is one of comprehensive environmental protection.

Our objectives are to use the natural resources which form the basis of our existence on this planet sparingly and in a manner which takes the requirements of both nature and humanity into consideration.

You too can help to protect the environment by operating your vehicle in an environmentally-responsible manner.

Fuel consumption and the rate of engine, transmission, brake and tyre wear depend on the following factors:

- operating conditions of your vehicle
- your personal driving style

You can influence both factors. Therefore, please bear the following in mind:

Operating conditions:

- avoid short trips, as these increase fuel consumption.
- observe the correct tyre pressure.
- do not carry any unnecessary weight in the vehicle.
- remove the roof rack once you no longer need it.
- a regularly serviced vehicle will contribute to environmental protection. You should therefore adhere to the service intervals.
- all maintenance work should be carried out at a qualified specialist workshop.

Personal driving style:

- do not depress the accelerator pedal when starting the engine.
- do not warm up the engine when the vehicle is stationary.
- drive carefully and maintain a safe distance from the vehicle in front.
- avoid frequent, sudden acceleration and braking.

- change gear in good time and use each gear only up to $\frac{2}{3}$ of its maximum engine speed.
- switch off the engine in stationary traffic.
- monitor the vehicle's fuel consumption.

Returning an end-of-life vehicle

EU countries only:

Mercedes-Benz will take back your old vehicle to dispose of it in an environmentally-responsible manner in accordance with the European Union (EU) End of Life Vehicles Directive.

There is a network of return points and disassembly plants available. You can return your vehicle to these plants free of charge. This makes a valuable contribution to the recycling process and the conservation of resources.

For further information on recycling old vehicles, recovery and the terms of the policy, visit the Mercedes-Benz homepage.

Genuine Mercedes-Benz parts

Environmental note

Daimler AG also supplies reconditioned assemblies and parts which are of the same quality as new parts. For these, the same warranty applies as for new parts.

! Airbags and seat belt tensioners, as well as control units and sensors for these restraint systems, may be installed in the following areas of your vehicle:

- doors
- door pillars
- door sills
- seats
- dashboard
- instrument cluster
- centre console

Do not install accessories such as audio systems in these areas. Do not carry out repairs or welding. You could impair the operating efficiency of the restraint systems.

Have accessories retrofitted at a qualified specialist workshop.

You could jeopardise the operating safety of your vehicle if you use parts, tyres and wheels as well as accessories relevant to safety which have not been approved by Mercedes. This could lead to malfunctions in safety-relevant systems, e.g. the brake system. Use only genuine Mercedes-Benz parts or parts of equal quality. Only use tyres, wheels and accessories that have been specifically approved for your vehicle.

Mercedes-Benz tests genuine parts and conversion parts and accessories that have been specifically approved for your vehicle for their reliability, safety and suitability. Despite ongoing market research, Mercedes-Benz is unable to assess other parts. Mercedes-Benz therefore accepts no responsibility for the use of such parts in Mercedes-Benz vehicles, even if they have been officially approved or independently approved by a testing centre. In Germany, certain parts are only officially approved for installation or modification if they comply with legal requirements. This also applies to some other countries. All genuine Mercedes-Benz parts meet the approval requirements. The use of non-approved parts may invalidate the vehicle's general operating permit.

This is the case:

- if they cause a change of the vehicle type from that for which the vehicle's general operating permit was granted
- if other road users could be endangered
- if the emission or noise levels are adversely affected

Always specify the vehicle identification number (VIN) (▷ page 468) when ordering genuine Mercedes-Benz parts.

Owner's Manual

Vehicle equipment

This Owner's Manual describes all models and all standard and optional equipment available for your vehicle at the time of publication of the Owner's Manual. Country-specific differences are possible. Note that your vehicle may not be fitted with all features described. This is also the case for systems and functions relevant to safety. Therefore, the equipment on your vehicle may differ from that in the descriptions and illustrations.

The original purchase contract documentation for your vehicle contains a list of all of the systems in your vehicle.

Should you have any questions concerning equipment and operation, please consult a Mercedes-Benz Service Centre.

The Owner's Manual and Service Booklet are important documents and should be kept in the vehicle.

Operating safety

Important safety notes

WARNING

If you do not have the prescribed service/maintenance work or necessary repairs carried out, this could result in malfunctions or system failures. There is a risk of an accident. Always have the prescribed service/maintenance work as well as necessary repairs carried out at a qualified specialist workshop.

WARNING

If you switch off the ignition while driving, safety-relevant functions are only available with limitations, or not at all. This could affect, for example, the power steering and the brake boosting effect. You will require considerably more effort to steer and brake. There is a risk of an accident.

Do not switch off the ignition while driving.

⚠ WARNING

Modifications to electronic components, their software as well as wiring could effect their function and/or the operation of other networked components. This could in particular also be the case for systems relevant to safety. They might not function properly any more and/or jeopardise the operational safety of the vehicle. There is an increased risk of an accident and injury.

Do not attempt to modify the wiring as well as electronic components or their software. Always have work on electrical and electronic components carried out at a qualified specialist workshop.

! There is a risk of damage to the vehicle if:

- the vehicle becomes stuck, e.g. on a high kerb or an unpaved road
- you drive too fast over an obstacle, e.g. a kerb or a pothole in the road
- a heavy object strikes the underbody or parts of the chassis

In situations like this, the body, the underbody, chassis parts, wheels or tyres could be damaged without the damage being visible. Components damaged in this way can unexpectedly fail or, in the case of an accident, no longer withstand the strain they are designed to.

If the underbody panelling is damaged, combustible materials such as leaves, grass or twigs can gather between the underbody and the underbody panelling. If these materials come in contact with hot parts of the exhaust system for an extended period, they can catch fire.

In such cases, have the vehicle checked and repaired immediately at a qualified specialist workshop. If on continuing your journey you notice that driving safety is impaired, pull over and stop the vehicle immediately, paying attention to road and traffic conditions. In such cases, visit a qualified specialist workshop.

Declarations of conformity**Wireless vehicle components**

The following information applies to all components of the vehicle and the information systems and communication devices integrated into the vehicle which receive and/or transmit radio waves:

The components of this vehicle that receive and/or transmit radio waves are compliant with the basic requirements and all other relevant conditions of Directive 1999/5/EC. You can obtain further information from any Mercedes-Benz Service Centre.

Electromagnetic compatibility

The electromagnetic compatibility of the vehicle components has been checked and certified according to the currently valid version of Regulation ECE-R 10.

Diagnostics connection

The diagnostics connection is only intended for the connection of diagnostic equipment at a qualified specialist workshop.

⚠ WARNING

If you connect equipment to a diagnostics connection in the vehicle, it can affect the operation of the vehicle systems. This may affect the operating safety of the vehicle. There is a risk of an accident.

Do not connect any equipment to a diagnostics connection in the vehicle.

⚠ WARNING

Objects in the driver's footwell may restrict the clearance around the pedals or block a depressed pedal. This jeopardises the operating and road safety of the vehicle. There is a risk of an accident.

Stow all objects securely in the vehicle so that they do not get into the driver's footwell. Always fit the floor mats securely and as prescribed in order to ensure that there is always

sufficient room for the pedals. Do not use loose floormats and do not place several floormats on top of one another.

- !** If the engine is switched off and equipment on the diagnostics connection is used, the starter battery may discharge.

Connecting equipment to the diagnostics connection can lead to emissions monitoring information being reset, for example. This may lead to the vehicle failing to meet the requirements of the next emissions test during the main inspection.

Qualified specialist workshop

A qualified specialist workshop has the necessary special skills, tools and qualifications to correctly carry out any necessary work on your vehicle. This particularly applies to work relevant to safety.

Observe the notes in the Service Booklet.

Always have the following work carried out at a qualified specialist workshop:

- work relevant to safety
- service and maintenance work
- repair work
- modifications, installations and conversions
- work on electronic components

Mercedes-Benz recommends that you use a Mercedes-Benz Service Centre.

Vehicle registration

Mercedes-Benz may ask its Service Centres to carry out technical inspections on certain vehicles. The quality or safety of the vehicle is improved as a result of the inspection.

Mercedes-Benz can only inform you about vehicle checks if it has your registration data.

It is possible that your vehicle has not yet been registered in your name in the following cases:

- if your vehicle was not purchased at an authorised specialist dealer.
- if your vehicle has not yet been examined at a Mercedes-Benz Service Centre.

It is advisable to register your vehicle with a Mercedes-Benz Service Centre.

Inform Mercedes-Benz as soon as possible about any change in address or vehicle ownership. You can do this at a Mercedes-Benz Service Centre, for example.

Correct use

If you remove any warning stickers, you or others could fail to recognise certain dangers. Leave warning stickers in position.

Observe the following information when driving your vehicle:

- the safety notes in this manual
- the technical data in this manual
- traffic rules and regulations
- laws and safety standards pertaining to motor vehicles

Implied warranty

! Follow the instructions in this manual about the proper operation of your vehicle as well as about possible vehicle damage. Damage to your vehicle that arises from culpable contraventions against these instructions are not covered either by Mercedes-Benz implied warranty or by the New or Used-Vehicle Warranty.

Data stored in the vehicle

A wide range of electronic components in your vehicle contain data memories.

These data memories temporarily or permanently store technical information about:

- the vehicle's operating state
- events
- faults

In general, this technical information documents the state of a component, a module, a system or the surroundings.

These include, for example:

- operating conditions of system components, e.g. fluid levels
- the vehicle's status messages and those of its individual components, e.g. number of wheel revolutions/speed, deceleration in movement, lateral acceleration, accelerator pedal position
- malfunctions and defects in important system components, e.g. lights, brakes
- vehicle reactions and operating conditions in special driving situations, e.g. airbag deployment, intervention of stability control systems
- ambient conditions, e.g. outside temperature

This data is of an exclusively technical nature and can be used to:

- assist in recognising and rectifying faults and defects
- analyse vehicle functions, e.g. after an accident
- optimise vehicle functions

The data cannot be used to trace the vehicle's movements.

When your vehicle is serviced, technical information can be read from the event data memory and fault data memory.

Services include, for example:

- repair services
- service processes
- warranties
- quality assurance

It is read by employees of the service network (including manufacturers) using special diag-

nostic testers. More detailed information is obtained from it, if required.

After a fault has been rectified, the information is deleted from the fault memory or is continually overwritten.

When operating the vehicle, situations are conceivable in which this technical data, in connection with other information (if necessary, under consultation with an authorised expert), could be traced to a person.

Examples include:

- accident reports
- damage to the vehicle
- witness statements

Further additional functions that have been contractually agreed upon with the customer allow certain vehicle data to be conveyed by the vehicle as well. The additional functions include, for example, vehicle location in case of an emergency.

Copyright information

General notes

Information on licences for free and open-source software used in your vehicle and its electronic components is available on the following website:

<http://www.mercedes-benz.com/opensource>

Cockpit	30
Instrument cluster	32
Multifunction steering wheel	35
Centre console	36
Overhead control panel	39
Door control panel	40

Cockpit

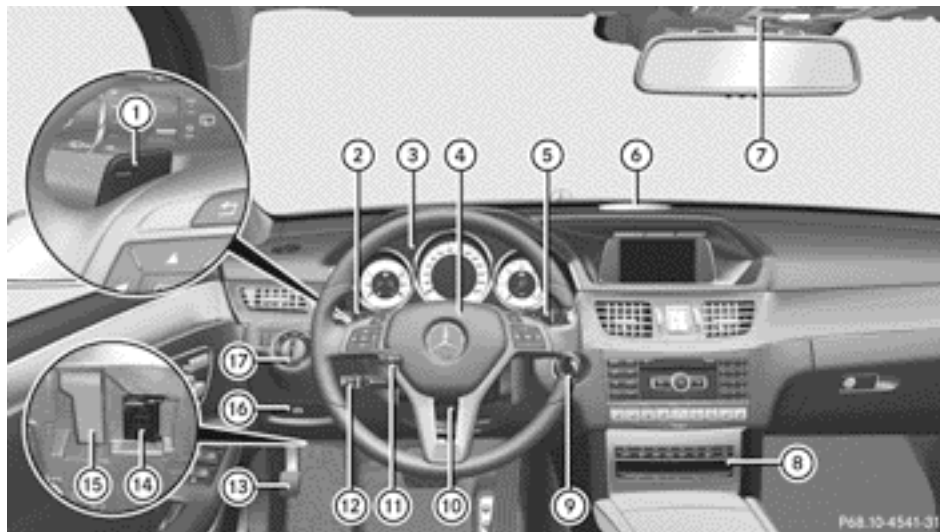

	Function	Page
①	Automatic transmission: steering wheel gearshift paddles	191
②	Combination switch	139
③	Instrument cluster	32
④	Horn	
⑤	DIRECT SELECT lever	187
⑥	PARKTRONIC warning display	228
⑦	Overhead control panel	39
⑧	Climate control systems	156
⑨	Ignition lock Start/Stop button	177 177

	Function	Page
⑩	Adjusting the steering wheel manually	126
⑪	Adjusting the steering wheel electrically Steering wheel heating	126 127
⑫	Cruise control lever	205
⑬	Parking brake	200
⑭	Diagnostics connection	25
⑮	Opening the bonnet	366
⑯	Releases the parking brake	200
⑰	Light switch	136

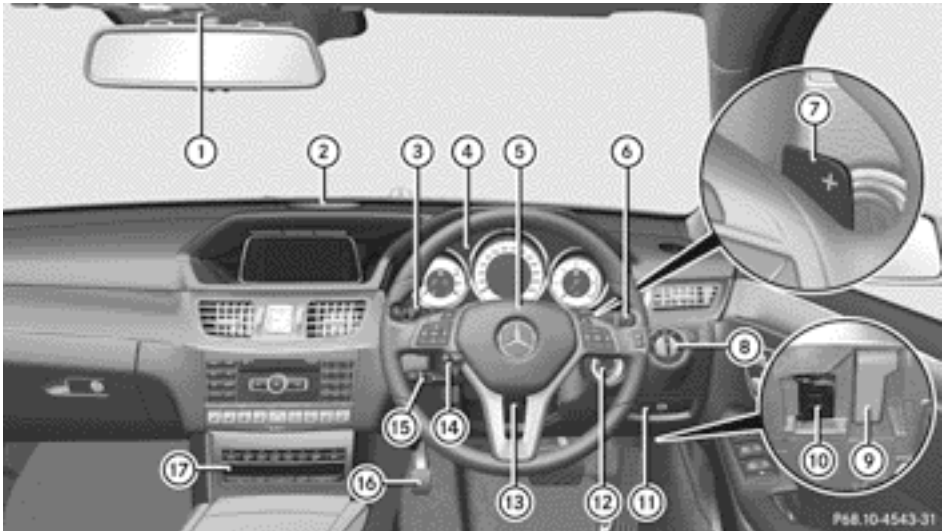

	Function	Page
①	Overhead control panel	39
②	PARKTRONIC warning display	228
③	Combination switch	139
④	Instrument cluster	32
⑤	Horn	
⑥	DIRECT SELECT lever	187
⑦	Steering wheel gearshift paddles	191
⑧	Light switch	136
⑨	Opening the bonnet	366
⑩	Diagnostics connection	25

	Function	Page
⑪	Releases the parking brake	200
⑫	Ignition lock	177
	Start/Stop button	177
⑬	Adjusting the steering wheel manually	
⑭	Adjusting the steering wheel electrically	126
	Steering wheel heating	127
⑮	Cruise control lever	205
⑯	Parking brake	200
⑰	Climate control systems	156

Instrument cluster

Displays

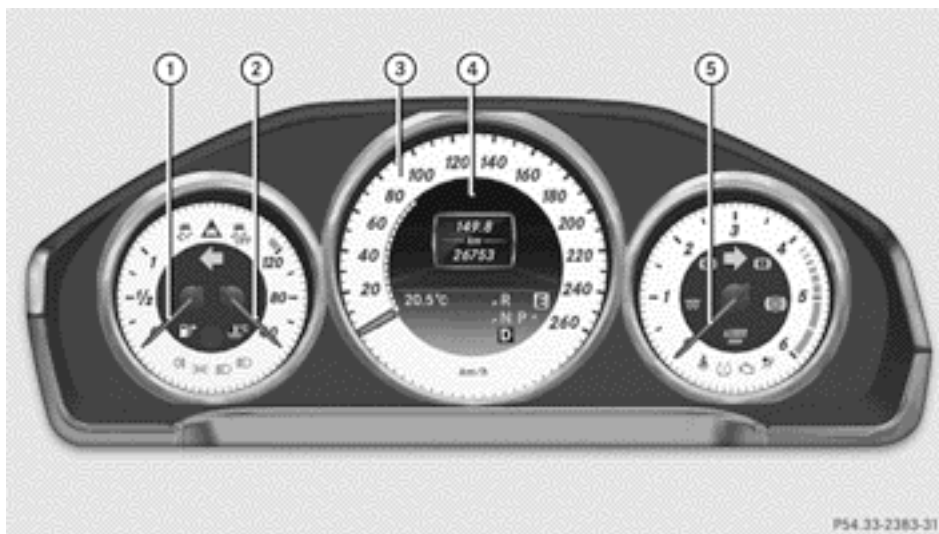

P54 33-2383-31

i Instrument cluster: kilometres

	Function	Page
①	Fuel gauge	
②	Coolant temperature	268
③	Speedometer with segments	269

	Function	Page
④	Multifunction display	270
⑤	Rev counter	268

i Set the instrument cluster lighting via the on-board computer (> page 281).

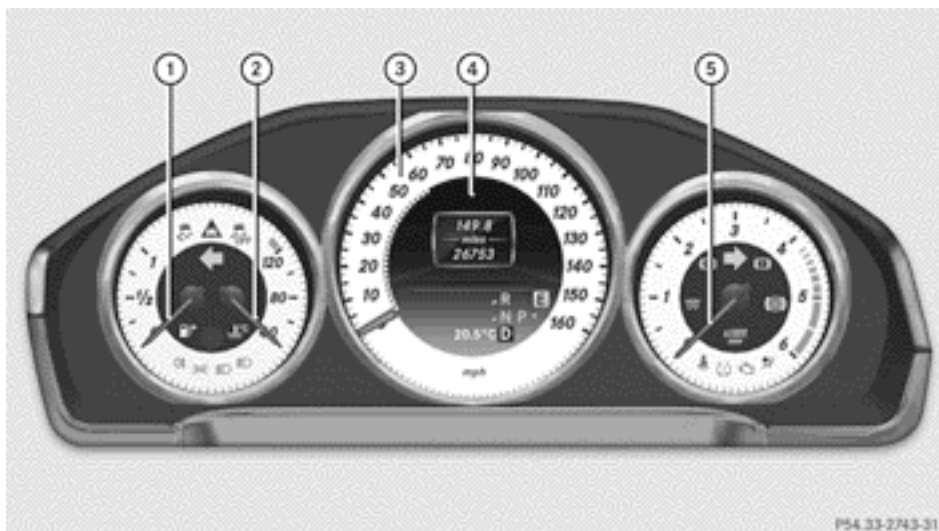

PS4.33-2743-31

i Instrument cluster: miles

	Function	Page
①	Fuel gauge	
②	Coolant temperature	268
③	Speedometer with segments	269

	Function	Page
④	Multifunction display	270
⑤	Rev counter	268

i Set the instrument cluster lighting via the on-board computer; see the Digital Owner's Manual.

Warning and indicator lamps

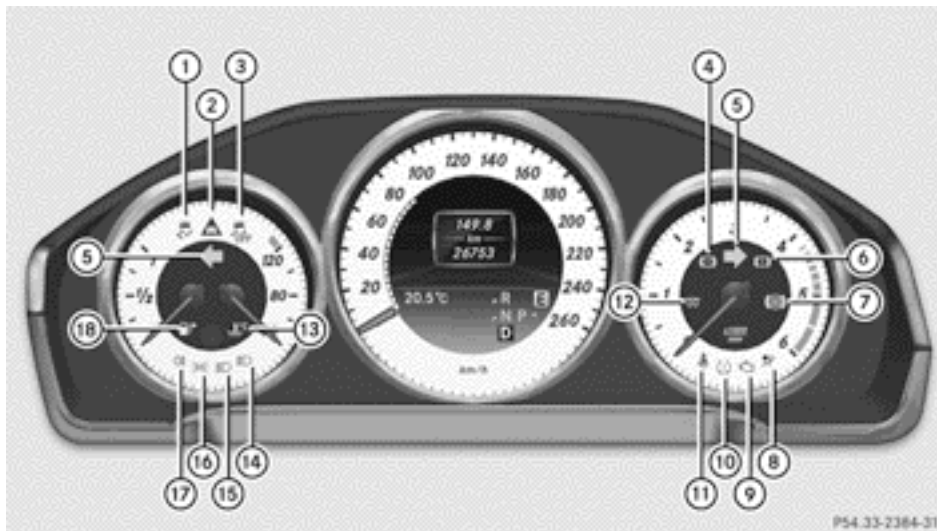





P54-33-2384-31



	Function	Page
①	ESP® SPORT handling mode in AMG vehicles	322 323
②	Distance warning	327
③	ESP® OFF	322
④	Brakes (red)	320
⑤	Turn signals	139
⑥	Only for certain vehicles: brakes (yellow)	320
⑦	ABS	321
⑧	SRS	324
⑨	Engine diagnostics	325
⑩	Tyre pressure monitor	328

	Function	Page
⑪	Seat belts	319
⑫	Diesel engine: pre-glow ESP® in AMG vehicles	179 323
⑬	Coolant	325
⑭	Main-beam headlamps	140
⑮	Dipped-beam headlamps	137
⑯	Side lamps	138
⑰	Rear foglamp	138
⑱	Reserve fuel	325

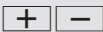
Multifunction steering wheel



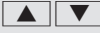





	Function	Page
①	Multifunction display	270
②	Audio/COMAND display; see the separate operating instructions	
③	 Switches on LINGUA-TRONIC; see the separate operating instructions	
④	 Rejects or ends a call Exits telephone book/redial memory  Makes or accepts a call Switches to the redial memory  Adjusts the volume  Mute	276

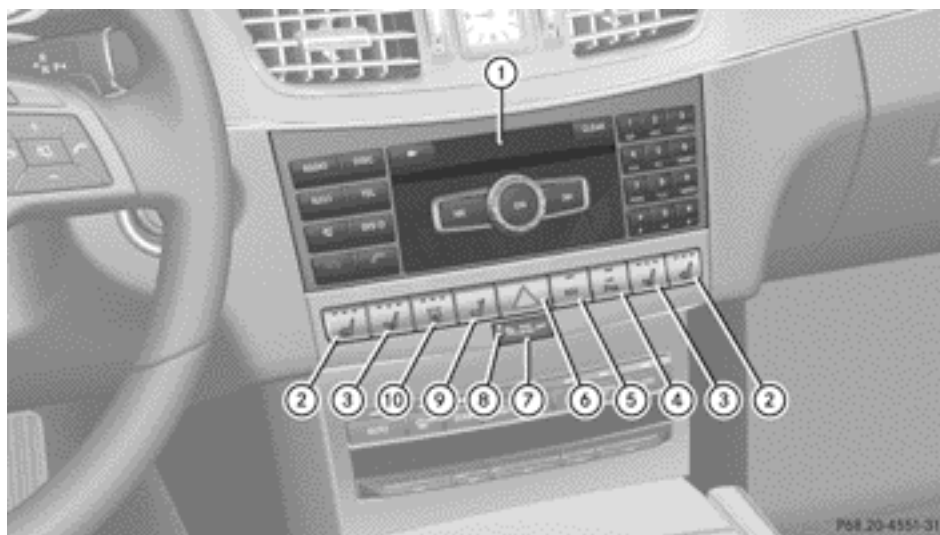



	Function	Page
⑤	 Selects a menu  Selects a submenu or scrolls through lists  Confirms the selection Hides display messages	269
⑥	 Back Switches off LINGUA-TRONIC; see the separate operating instructions	269

Centre console

Centre console, upper section





	Function	Page
①	Audio system/COMAND Online; see the separate operating instructions	
②	 Seat heating	123
③	 Seat ventilation	125
④	 PARKTRONIC	228
⑤	 start/stop function	181
⑥	 Hazard warning lamps	140

	Function	Page
⑦	 PASSENGER AIRBAG OFF indicator lamp	57
⑧	ATA indicator lamp	83
⑨	 Retracts the rear seat head restraints	118
⑩	 Auxiliary heating	168
	 Saloon: rear window roller sunblind	351

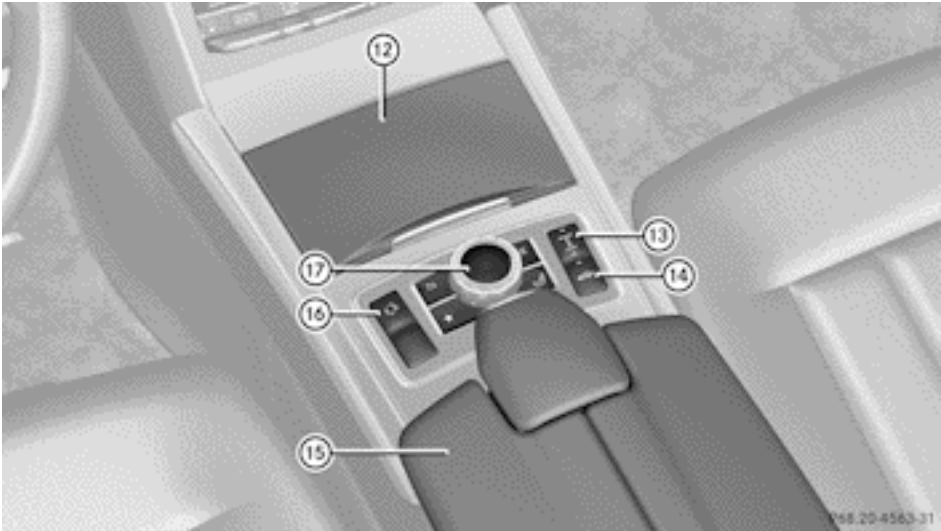
Centre console, lower section



i Vehicles with DIRECT SELECT lever



	Function	Page
⑫	Stowage compartment Ashtray Cigarette lighter Cup holders	330 351 352 348
⑬	 Adjusts the suspension setting	225
⑭	 Sets the vehicle level	224

	Function	Page
⑮	Stowage compartment	330
⑯	 Selects the drive program	190
⑰	COMAND controller; see the separate operating instructions	

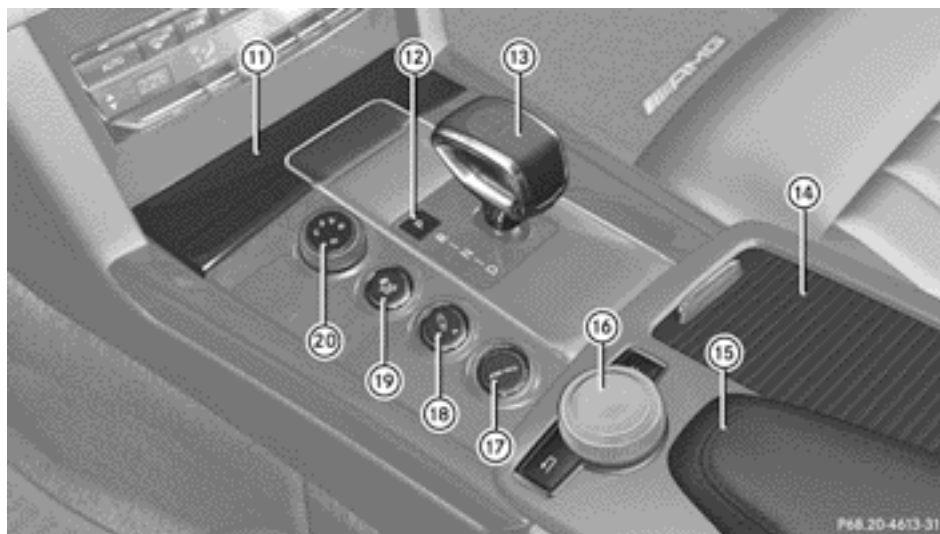
Centre console, lower section (AMG vehicles)









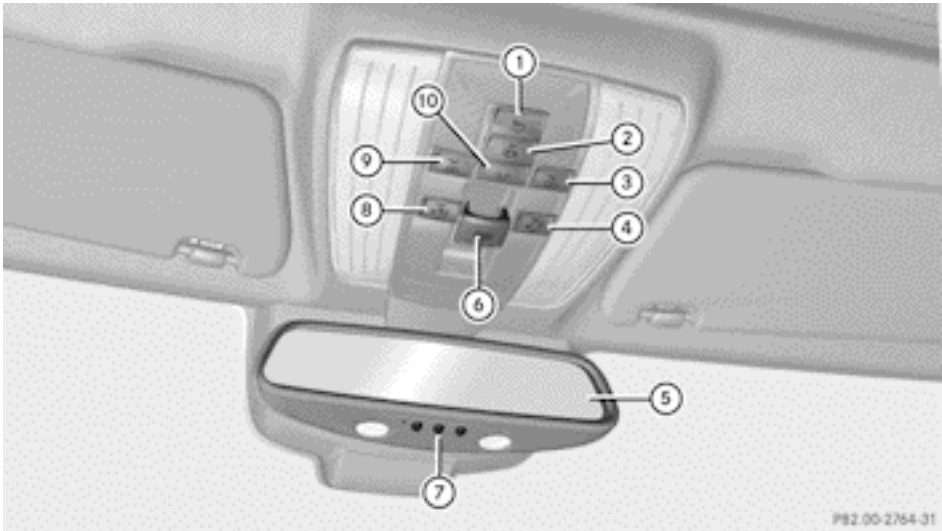

	Function	Page
⑪	Ashtray Cigarette lighter	351 352
⑫	Engages parking position P	199
⑬	Selector lever	186
⑭	Cup holders	348
⑮	Stowage compartment	330
⑯	Audio/COMAND controller; see the separate operating instructions	

	Function	Page
⑰	 Calls up/saves the suspension tuning	226
⑱	 Adjusts the suspension setting	226
⑲	 ESP®	79
⑳	Drive program selector	190

Overhead control panel











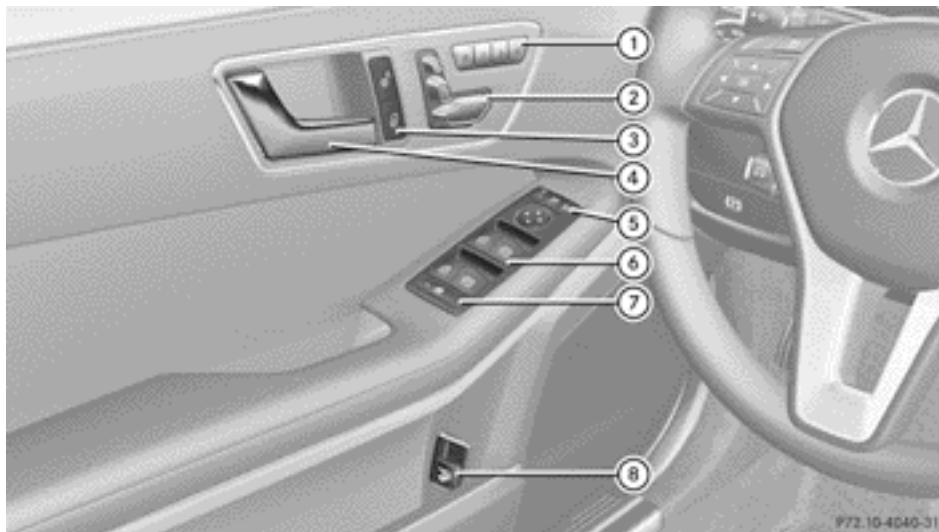

P82.00-2764-31

	Function	Page		Function	Page
①	 Switches the rear interior lighting on/off	147		 Opens/closes the panorama sliding sunroof with roller sunblinds	110
②	 Switches the automatic interior lighting control on/off	147	⑦	Buttons for the garage door opener	355
③	 Switches the right-hand reading lamp on/off	146	⑧	 Deactivates the interior motion sensor	85
④	 Deactivates the tow-away protection	84	⑨	 Switches the left-hand reading lamp on/off	146
⑤	Rear-view mirror	131	⑩	 Switches the front interior lighting on/off	147
⑥	 Opens/closes the sliding sunroof	108			

Door control panel

At a glance



	Function	Page
①	 1 2 3 Stores settings for the seat, exterior mirrors and steering wheel	132
②	Adjusts the seats electrically	116
③	  Unlocks/locks the vehicle	95
④	Opens the door	95
⑤	    Adjusts and folds the exterior mirrors in/out electrically	129
⑥	 Opens/closes the side windows	104
⑦	 Activates/deactivates the override feature for the side windows in the rear compartment	71
⑧	 Opens/closes the boot lid/tailgate	101

Useful information	42
Panic alarm	42
Occupant safety	42
Children in the vehicle	55
Driving safety systems	71
Anti-theft systems	83

Useful information

- i** This Owner's Manual describes all models, series and optional equipment for your vehicle that were available at the time of going to press. National variations are possible. Note that your vehicle may not be equipped with all of the functions described. This is also the case for systems and functions relevant to safety.
- i** Read the information on qualified specialist workshops: (▷ page 26).

Panic alarm



- ▶ **To activate:** press **PANIC** button **i** for approximately one second.
An alarm sounds and the exterior lighting flashes.
 - ▶ **To deactivate:** press **PANIC** button **i** again.
- or
- ▶ Insert the key into the ignition lock.
- or
- ▶ Press the KEYLESS-GO Start/Stop button.
The KEYLESS-GO key must be in the vehicle.
- i** The panic alarm function is only available in certain countries.

Occupant safety

Important safety notes

⚠ WARNING

Modifications to the restraint systems could result in them not functioning properly any more. The restraint systems could then no longer protect vehicle occupants as they are designed to do and could fail in the event of an accident or activate unexpectedly, for example. There is an increased risk of injury. Never modify parts of the restraint systems. Do not attempt to modify the wiring as well as electronic components or their software.

The airbag system can be adapted for a person with disabilities. For further information, consult a Mercedes-Benz Service Centre.

The seat belts, together with SRS (Supplemental Restraint System), are complementary, co-ordinated restraint systems (▷ page 43). They reduce the risk of injury in specific, pre-defined types of accident situations and thereby increase occupant safety. However, seat belts and airbags generally do not protect against objects penetrating the vehicle from the outside.

To ensure that the restraint systems can deliver their full potential protection, make sure that:

- the seat and head restraint are adjusted properly (▷ page 114)
- the seat belt has been fastened properly (▷ page 51)
- the airbags can inflate without restriction if deployed (▷ page 44)
- the steering wheel is adjusted properly (▷ page 126)
- the restraint systems have not been modified

An airbag increases the protection of vehicle occupants wearing a seat belt. However, airbags are only an additional restraint system that complements, but does not replace, the seat belt. All vehicle occupants must wear

their seat belt correctly at all times, even if the vehicle is equipped with airbags. The airbags are not deployed in all types of accidents. For example, if the protective capacity of correctly fastened seat belts is not increased by deploying the airbags, the airbags will not deploy.

Airbag deployment only provides increased protection if the seat belt is worn correctly. The seat belt helps, firstly, to keep the vehicle occupant in the best position in relation to the airbag. Secondly, in a head-on collision, for example, the seat belt restricts movement of the vehicle occupant towards the point of impact.

SRS (Supplemental Restraint System)

Introduction

SRS consists of:

- the  SRS warning lamp
- airbags
- the airbag control unit with crash sensors
- belt tensioners for the front seat belts and the outer seat belts in the rear
- seat belt force limiters for the front seat belts and the outer seat belts in the rear

SRS reduces the risk of occupants coming into contact with the vehicle's interior in the event of an accident. It can also reduce the forces to which occupants are subjected during an accident.

SRS warning lamp

WARNING

If SRS is malfunctioning, child restraint system components may be triggered unintentionally or might not be triggered at all in the event of an accident with a high rate of vehicle deceleration. There is an increased risk of injury, possibly even fatal.



Have SRS checked and repaired immediately at a qualified specialist workshop.

SRS functions are checked regularly when you switch on the ignition and when the engine is running. Therefore, malfunctions can be detected in good time.

The  SRS warning lamp in the instrument cluster lights up when the ignition is switched on. It goes out no later than a few seconds after the engine is started.

The SRS components are in operational readiness when the  SRS warning lamp goes out while the engine is running.

A malfunction has occurred if:

- the  SRS warning lamp does not light up when the ignition is switched on
- the engine is running and the  SRS warning lamp does not go out after a few seconds
- the engine is running and the  SRS warning lamp lights up again

Triggering of belt tensioners and airbags

During the first stage of a collision, the airbag control unit evaluates important physical data relating to vehicle deceleration or acceleration, such as:

- duration
- direction
- magnitude

Based on the evaluation of this data, the airbag control unit pre-emptively triggers the belt tensioners in the first stage.

If there is an even higher rate of vehicle deceleration or acceleration in a longitudinal direction, the front airbags are also deployed.

Your vehicle has adaptive, two-stage front airbags. The airbag control unit evaluates vehicle deceleration or acceleration in the event of a collision. In the first deployment stage, the front airbag is filled with enough propellant gas to reduce the risk of injuries. The front airbag is fully deployed if a second deployment threshold is reached within a few milliseconds.

The belt tensioner and airbag triggering thresholds are variable and are adapted to the rate of deceleration or acceleration of the vehicle. This process is pre-emptive in nature. The triggering process must take place in good time at the start of the collision.

The rate of vehicle deceleration or acceleration and the direction of the force are essentially determined by:

- the distribution of forces during the collision
- the collision angle
- the deformation characteristics of the vehicle
- the characteristics of the object with which the vehicle has collided

Factors which can only be seen and measured after a collision has occurred do not play a decisive role in the deployment of an airbag, nor do they provide an indication of airbag deployment.

The vehicle may be deformed significantly, e.g. the bonnet or the wing, without an airbag being deployed. This is the case if only parts which are relatively easily deformed are affected and the rate of deceleration is not high. Conversely, airbags may be deployed even though the vehicle suffers only minor deformation. This is the case if, for example, very rigid vehicle parts such as longitudinal body members are hit, and sufficient deceleration occurs as a result.

- i** The front belt tensioners can only be triggered if the seat belt tongues on the front seats are correctly engaged in the seat belt buckles.
- i** Not all airbags are deployed in an accident. The different airbag systems work independently of each other.

How the airbag system works is determined by the severity of the accident detected, especially the vehicle deceleration or acceleration, and the apparent type of accident:

- frontal collision
- side impact
- overturn

Airbags

Important safety notes

WARNING

Airbags provide additional protection; they are not, however, a substitute for seat belts.

Observe the following notes to reduce the risk of serious or even fatal injury caused by airbag deployment:

- all vehicle occupants – in particular, pregnant women – must wear their seat belt correctly at all times and lean back against the backrest, which should be positioned as close to the vertical as possible. The head restraint must support the back of the head at about eye level.
- always secure children less than 1.50 m tall or under 12 years of age in suitable child restraint systems.
- all vehicle occupants must select a seat position that is as far away from the airbag as possible. The driver's seat position must allow the vehicle to be driven safely. The driver's chest should be as far away from the centre of the driver's airbag cover as possible.
- move the front-passenger seat as far back as possible. This is especially important if you have secured a child in a child restraint system on the front-passenger seat.
- vehicle occupants – in particular, children – must not lean their head into the area of the window in which the sidebag/windowbag is deployed.

- rearward-facing child restraint systems must not be fitted to the front-passenger seat unless the front-passenger airbag has been disabled. On the front-passenger seat, the front-passenger airbag is disabled if a child restraint system with a transponder for automatic child seat recognition is fitted to the front-passenger seat in a vehicle equipped with automatic child seat recognition. The  PASSENGER AIRBAG OFF indicator lamp must be continuously lit.

If the front-passenger seat of your vehicle does not have automatic child seat recognition, or your rearward-facing child restraint system does not have a transponder for automatic child seat recognition, children must be secured in a child restraint system on a suitable seat in the rear. If you secure a forward-facing child restraint system to the front-passenger seat, you must move the front-passenger seat as far back as possible.

- make sure there are no heavy or sharp-edged objects in the pockets of clothing.
- do not lean forwards, e.g. over the cover of the driver's/front-passenger front airbag, particularly when the vehicle is in motion.
- do not put your feet on the dashboard.
- only hold the steering wheel on the outside. This allows the airbag to be fully deployed. You could be injured if the airbag is deployed and you are holding the inside of the steering wheel.
- do not lean on the doors from inside the vehicle.
- make sure that there are no people, animals or objects between the vehicle occupants and the area where the airbags are deployed.
- do not place any objects between the seat backrest and the door.

- do not hang any hard objects, e.g. coat hangers, on the grab handles or coat hooks.
- do not attach accessories, e.g. cup holders, to the doors.

It is not possible to rule out a risk of injury being caused by an airbag, due to the high speed at which the airbag must be deployed.

WARNING

If you modify the airbag covers or affix objects, e.g. stickers to them, the airbags may no longer function as intended. There is an increased risk of injury.

Never modify the airbag covers and do not affix any objects to them.

WARNING

Unsuitable seat covers may obstruct or even prevent deployment of the airbags integrated into the seats. The airbags may then fail to protect the vehicle occupants as intended. Operation of the automatic child seat recognition may also be impaired. There is an increased risk of injury, possibly even fatal.

Use only seat covers which have been specifically approved for the respective seat by Mercedes-Benz.

WARNING

After the driver's airbag has been deployed, the airbag parts are hot. There is a risk of injury.

Do not touch the airbag parts. Have deployed airbags replaced immediately at a qualified specialist workshop.

Airbag deployment slows down and restricts the movement of the vehicle occupant.

If the airbags are deployed, you will hear a bang and a small amount of powder may also be released. Only in rare cases will the bang affect your hearing. The powder that is released generally does not constitute a health hazard and does not indicate that there is a fire in the vehicle. The powder may cause short-term breathing difficulties to persons

suffering from asthma or other pulmonary conditions. In order to prevent potential breathing difficulties, you should leave the vehicle as soon as it is safe to do so. You can also open the window to allow fresh air to enter the vehicle interior. The  SRS warning lamp lights up.

The airbag installation locations are identified by the AIRBAG symbol.

- i** After an airbag has been deployed, have the vehicle towed to the nearest qualified specialist workshop, even if your vehicle can still be driven.

Front airbags

! Do not place heavy objects on the front-passenger seat. This could cause the system to identify the seat as being occupied. In the event of an accident, the restraint systems on the front-passenger side may be triggered and have to be replaced.



Driver's airbag ① deploys in front of the steering wheel; front-passenger front airbag ② deploys in front of and above the glove compartment.

The front airbags increase protection for the driver's and front-passenger's head and chest.

They are deployed:

- at the start of an accident with a high rate of vehicle acceleration or deceleration in a longitudinal direction.
- if the system determines that airbag deployment can offer additional protection to that provided by the seat belt.
- independently of other airbags in the vehicle.

The time within which the front airbag is deployed is dependent on whether or not a seat belt is worn.

If the vehicle overturns, the front airbags are generally not deployed.

Vehicles with automatic child seat recognition in the front-passenger seat: front-passenger front airbag ② is only activated if the system determines that the front-passenger seat is occupied. The PASSENGER AIRBAG OFF indicator lamp on the centre console does not light up (▷ page 57).

If a child restraint system is fitted to the front-passenger seat and the PASSENGER AIRBAG OFF indicator lamp on the centre console is not on:

- a child restraint system without a transponder for automatic child seat recognition has been fitted or
- a child restraint system with a transponder has been fitted incorrectly

Driver's kneebag



Driver's kneebag ① deploys under the steering column. It deploys together with the front

airbags. The driver's kneebag is designed to operate together with the front airbags in frontal impacts if certain thresholds are exceeded. The driver's kneebag operates best in conjunction with correctly positioned and fastened seat belts.

The driver's kneebag increases protection of the driver against:

- knee injuries
- thigh injuries
- lower leg injuries

i The driver's kneebag is only available in certain countries.

Sidebags

⚠ WARNING

Unsuitable seat covers may obstruct or even prevent deployment of the airbags integrated into the seats. The airbags may then fail to protect the vehicle occupants as intended. Operation of the automatic child seat recognition may also be impaired. There is an increased risk of injury, possibly even fatal.

Use only seat covers which have been specifically approved for the respective seat by Mercedes-Benz.

⚠ WARNING

Sensors to control the airbags are located in the doors. Modifications or work not performed correctly to the doors or door paneling, as well as damaged doors, can lead to the function of the sensors being impaired. The airbags might therefore not function properly any more. Consequently, the airbags cannot protect vehicle occupants as they are designed to do. This poses an increased risk of injury.

Never modify the doors or parts of the doors. Always have work on the doors or door paneling carried out at a qualified specialist workshop.

You should only use seat covers that have been approved for your vehicle by Mercedes-

Benz. The seat covers must have a special tear seam for sidebags. Otherwise, the sidebags cannot deploy correctly and therefore cannot provide the intended protection in the event of an accident.

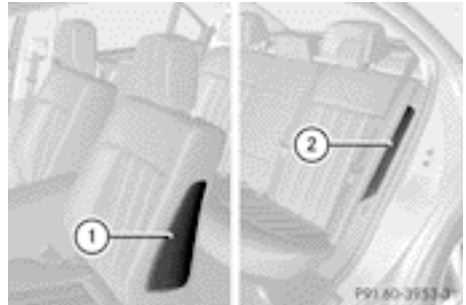

Sidebags (example: Saloon)

Front sidebags ① and rear sidebags ② deploy next to the outer seat cushions.

When deployed, the sidebags offer additional thorax protection for vehicle occupants on the side of the vehicle on which the impact occurs. However, they do not protect the:

- head
- neck
- arms

The sidebags are deployed:

- on the side on which an impact occurs
- at the start of an accident with a high rate of lateral vehicle deceleration or acceleration, e.g. in a side impact
- independently of the use of the seat belt
- independently of the front airbags
- independently of the belt tensioners

If the vehicle overturns, the sidebags are generally not deployed. Sidebags are deployed if the system detects high vehicle deceleration or acceleration in a lateral direction and determines that sidebag deployment can offer additional protection to that provided by the seat belts.

Pelvisbags

WARNING

If you wish to use seat covers, Mercedes-Benz recommends that, for safety reasons, you only use seat covers that have been approved for Mercedes-Benz vehicles.

The seat covers must have a special tear seam for sidebags/pelvisbags. Otherwise, the sidebag/pelvisbag cannot deploy correctly and would fail to provide the intended protection in the event of an accident. Appropriate seat covers can be obtained, for example, from a Mercedes-Benz Service Centre.



Pelvisbags ① enhance the level of protection of the vehicle occupants on the side of the vehicle on which the impact occurs.

Pelvisbags deploy next to and below the outer seat cushions. They are deployed:

- on the side on which an impact occurs
- at the start of an accident with a high rate of lateral vehicle deceleration or acceleration, e.g. in a side impact
- independently of the use of the seat belt
- independently of the front airbags
- independently of the belt tensioners

If the vehicle overturns, the pelvisbags are generally not deployed. Sidebags are deployed if the system detects high vehicle deceleration or acceleration in a lateral direction and determines that sidebag deployment can offer additional protection to that provided by the seat belt.

i Pelvisbags are only available in certain countries.

Windowbags

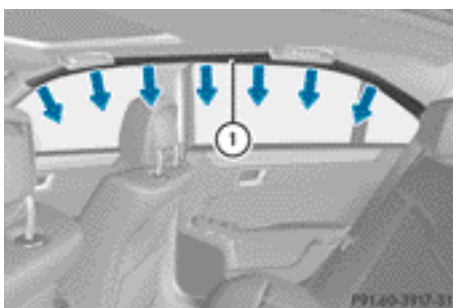

Windowbags on the front-passenger side (example: Saloon)

Windowbags ① enhance the level of protection for the head (but not chest or arms), of the vehicle occupants on the side of the vehicle on which the impact occurs.

The windowbags are integrated into the side of the roof frame and deployed in the area from the A-pillar to the C-pillar.

Windowbags are deployed:

- at the start of an accident with a high rate of lateral vehicle deceleration or acceleration, e.g. in a side impact
- on the side on which an impact occurs
- on the driver's and the front-passenger's side if the vehicle overturns and the system determines that deployment can offer additional protection to that provided by the seat belt
- independently of the use of the seat belt
- regardless of whether the front-passenger seat is occupied
- independently of the front airbags

NECK-PRO head restraints/NECK-PRO luxury head restraints

Important safety notes

WARNING

The function of the head restraint may be impaired if you:

- attach objects such as coat hangers to the head restraints, for example
- use head restraint covers

If you do so, the head restraints cannot fulfil their intended protective function in the event of an accident. In addition, objects attached to the head restraints could endanger other vehicle occupants. This poses an increased risk of injury.

Do not attach any objects to the head restraints and do not use head restraint covers.

NECK-PRO head restraints/NECK-PRO luxury head restraints increase protection of the driver's and front-passenger's head and neck. In the event of a rear collision of a certain severity, the NECK-PRO head restraints/NECK-PRO luxury head restraints on the driver's and front-passenger seats are moved forwards and upwards. This provides better head support.

If the NECK-PRO head restraints/NECK-PRO luxury head restraints have been triggered in an accident, reset the NECK-PRO head restraints/NECK-PRO luxury head restraints on the driver's and front-passenger seats (▷ page 49). Otherwise, the additional protection will not be available in the event of another rear-end collision. NECK-PRO head restraints/NECK-PRO luxury head restraints that have been triggered are moved forwards and can no longer be adjusted.

Mercedes-Benz recommends that you have the NECK-PRO head restraints/NECK-PRO luxury head restraints checked at a qualified specialist workshop after a rear-end collision.

Resetting a triggered NECK-PRO head restraint/NECK-PRO luxury head restraint

NECK-PRO head restraints

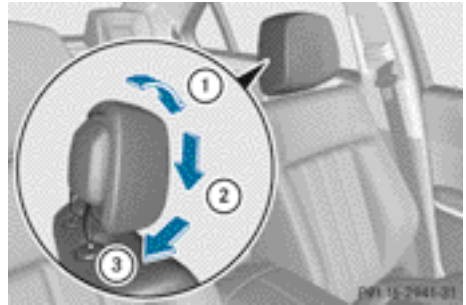

NECK-PRO head restraint (example: Saloon)

- ▶ Tilt the top of the NECK-PRO head restraint cushion forwards in the direction of arrow ①.
- ▶ Push the NECK-PRO head restraint cushion down in the direction of arrow ② as far as it will go.
- ▶ With your hand flat, firmly push the NECK-PRO head restraint cushion backwards in the direction of arrow ③ until it engages.
- ▶ Repeat this procedure for the second NECK-PRO head restraint.

NECK-PRO luxury head restraint

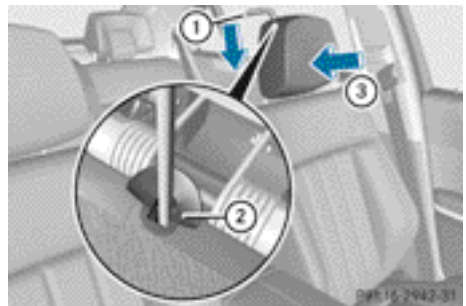

NECK-PRO luxury head restraint

- ▶ Remove resetting tool ① from the vehicle document wallet.
 - ▶ Slide resetting tool ① into guide ② between the NECK-PRO luxury head restraint and the rear cover of the head restraint.
 - ▶ Push resetting tool ① downwards until you hear the head restraint deployment mechanism engage.
 - ▶ Pull out resetting tool ①.
 - ▶ With your hand flat, firmly push the NECK-PRO luxury head restraint cushion backwards in the direction of arrow ③ until it engages.
 - ▶ Repeat this procedure for the second NECK-PRO luxury head restraint.
 - ▶ Put resetting tool ① back into the vehicle document wallet.
- i** If you have difficulty resetting the NECK-PRO luxury head restraints, have this work carried out at a qualified specialist workshop.

PRE-SAFE® (anticipatory occupant protection)

- !** Make sure that there are no objects in the footwell or behind the seats when moving the seat back. There is a risk that the seats and/or the objects could be damaged.

PRE-SAFE® takes pre-emptive measures to protect occupants in certain hazardous situations. Although your vehicle is equipped with a PRE-SAFE® system, the possibility of injury in the event of an accident cannot be ruled out.

Always adapt your driving style to suit the prevailing road and weather conditions and maintain a safe distance from the vehicle in front. Drive carefully.

PRE-SAFE® intervenes:

- when BAS activates, e.g. in emergency braking situations
- when BAS PLUS – on vehicles with DISTRONIC PLUS – intervenes heavily
- if, on vehicles with DISTRONIC PLUS, the radar sensor system detects an imminent danger of collision in certain situations
- in critical driving situations, e.g. when physical limits are exceeded and the vehicle understeers or oversteers severely

PRE-SAFE® takes the following measures depending on the hazardous situation detected:

- the front seat belts are pre-tensioned.
- vehicles with the memory function: the front-passenger seat is adjusted if it is in an unfavourable position.
- vehicles with a multicontour seat or active multicontour seat: the air pressure in the side bolsters of the seat cushion and backrest is increased.
- if the vehicle skids, the sliding sunroof and the side windows are closed so that only a small gap remains. On vehicles with a panorama sliding sunroof, this is closed completely.

If the hazardous situation passes without resulting in an accident, PRE-SAFE® slackens the belt pretensioning. The air pressure in the side bolsters on the multicontour seats/ active multicontour seats is reduced again. All settings made by PRE-SAFE® can then be reversed.

If the seat belts are not released:

- ▶ Move the backrest or seat back slightly, but only when the vehicle is stationary. Seat belt pretensioning is reduced and the locking mechanism is released.

More information about seat belt adjustment, a convenience function integrated into PRE-SAFE®, can be found under "Seat belt adjustment" (> page 52).

Seat belts

Important safety notes

WARNING

A seat belt which is not worn correctly, or which has not been engaged in the seat belt buckle correctly, cannot provide the intended level of protection. Under certain circumstances, this could cause severe or even fatal injuries in the event of an accident.

Therefore, make sure that all occupants – in particular, pregnant women – wear their seat belts correctly at all times.

- The seat belt must fit snugly on your body and must not be twisted. Therefore, avoid wearing bulky clothing, e.g. a winter coat. The shoulder section of the belt must be routed across the centre of your shoulder – on no account across your neck or under your arm – and pulled tight against your upper body. The lap belt must always pass across your lap as low down as possible, i.e. over your hip joints – not across your abdomen. If necessary, push the seat belt slightly downwards and adjust it by pulling it in the direction the seat belt retracts.
- Do not route the seat belt strap over sharp or fragile objects. Please make sure that such objects are not on or in your clothing, e.g. spectacles, pens or keys etc. The seat belt strap could become damaged and tear during an accident and you or other vehicle occupants could be injured.
- Only one person should use each seat belt at any one time. Children must never travel sitting on the lap of another occupant. The child will not be secured in the event of an accident, heavy braking or sudden change of direction. This may result in the child or other occupants being seriously or fatally injured.
- Persons under 1.50 m tall cannot wear the seat belts correctly. For this reason secure persons less than 1.50 m tall in specially designed, suitable restraint systems.

- Children under 1.50 m tall and younger than twelve years of age cannot wear the seat belts correctly. For this reason secure them in special suitable child restraint systems installed on a suitable seat. Additional information can be found in the Operating Instructions in the chapter "Safety", "Children in the Vehicle". Observe the installation instructions of the child restraint system manufacturer.

- Do not secure an object with a seat belt if the seat belt is also being used by one of the vehicle's occupants.

WARNING

The seat belt does not offer the intended level of protection if the backrest is not in the upright position. When braking or in the event of an accident, you could slide underneath the seat belt and sustain abdomen or neck injuries, for example. This poses an increased risk of injury or even fatal injury.

Adjust the seat properly before beginning your journey. Always make sure that the seat is in the upright position.

WARNING

Seat belts cannot perform their intended protective function if:

- they are damaged, modified, bleached or coloured, or are very dirty
- the seat belt buckle is damaged or very dirty
- modifications have been made to the seat belt tensioners or belt anchorages

In the event of an accident, seat belts can sustain damage that is not visible to the naked eye, e.g. due to glass splinters. Modified or damaged seat belts could tear or fail in the event of an accident, for example. Modified belt tensioners could deploy unexpectedly or fail. There is an increased risk of serious or even fatal injuries.

Never make modifications to seat belts, belt tensioners, belt anchorages or seat belt

retractors. Make sure that the seat belts are undamaged, are not worn and are clean.

Mercedes-Benz recommends that you only use seat belts which have been approved specifically for your vehicle by Mercedes-Benz.

Seat belts are the most effective means of restraining the movement of vehicle occupants in the event of an accident. This reduces the risk of vehicle occupants coming into contact with parts of the vehicle interior.

Fastening seat belts

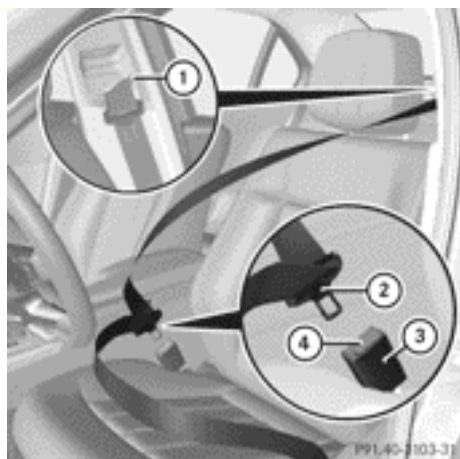

Seat belt (example: Saloon)

- ▶ Adjust the seat and move the backrest to an almost vertical position (▷ page 114).
- ▶ Pull the seat belt smoothly through belt sash guide ①.
- ▶ Without twisting it, guide the shoulder section of the seat belt across the middle of your shoulder and the lap section across your pelvis.
- ▶ Engage belt tongue ② in buckle ③. Seat belt adjustment: if necessary, the driver's and front-passenger seat belts automatically adjust to the upper body (▷ page 52).

- ▶ If necessary, adjust the seat belt to the appropriate height (▷ page 52).
- ▶ If necessary, pull upwards on the shoulder section of the seat belt to tighten the belt across your body.

Information on releasing the seat belt with release button ④ (▷ page 53).

Seat belt adjustment

The seat-belt adjustment function adjusts the driver's and front-passenger seat belt to the upper body of the occupants.

The belt strap is tightened slightly when:

- you engage the belt tongue in the belt buckle and you then turn the key to position 2 in the ignition lock.
- the key is in position 2 in the ignition lock and you then engage the belt tongue in the buckle.

The seat-belt adjustment will apply a certain tightening force if any slack is detected between the occupant and the seat belt. Do not hold on to the seat belt tightly while it is adjusting. You can switch the belt adjustment on and off in the on-board computer (▷ page 286).

The seat-belt adjustment is an integral part of the PRE-SAFE® convenience function. More information about PRE-SAFE® can be found under "PRE-SAFE® (preventative occupant protection)" (▷ page 50).

Belt height adjustment

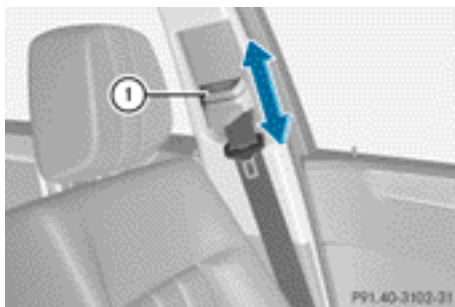

You can adjust the belt height for the front seats. **Estate:** you can also adjust the belt height on the outer rear seats. Adjust the belt to a height that allows the upper part of the seat belt to be routed across the centre of your shoulder.

- ▶ **To raise:** slide the belt sash guide upwards. The belt sash guide engages in various positions.
- ▶ **To lower:** press and hold belt sash guide release ①.
- ▶ Slide the belt sash guide downwards.
- ▶ Let go of belt sash guide release ① and make sure that the belt sash guide has engaged.

Wearing the rear centre seat belt

If the left-hand rear seat backrest is folded down and back up again, the rear centre seat belt may lock. The seat belt can then not be pulled out.

- ▶ **To release the rear centre seat belt:** pull the seat belt out approximately 20 mm at the belt outlet on the backrest and then release it again. The seat belt is retracted and released.

Releasing the seat belts

- ❗ Make sure that the seat belt is fully rolled up. Otherwise, the seat belt or belt tongue will be trapped in the door or in the seat mechanism. This could damage the door, the door trim panel and the seat belt. Damaged seat belts can no longer fulfil their protective function and must be replaced. Visit a qualified specialist workshop.

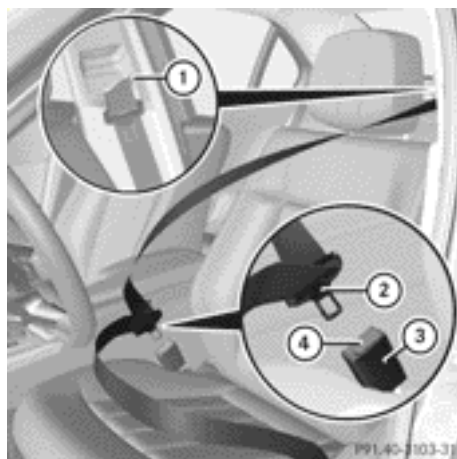



Seat belt (example: Saloon)

- ▶ Press release button ④ on belt buckle ③.
- ▶ Guide belt tongue ② back to belt sash guide ①.

Belt warning for the driver and front passenger

The  seat belt warning lamp in the instrument cluster is a reminder for all occupants to fasten their seat belts. It may light up continuously or flash. In addition, a warning tone may sound.

The  seat belt warning lamp goes out and the warning tone ceases when the driver and the front passenger have fastened their seat belt.



For certain countries only: regardless of whether the driver and the front passenger have fastened their seat belts, the  seat belt warning lamp lights up for six seconds after the engine is started. It then goes out if the driver and the front passenger have fastened their seat belts.

- ❗ For more information on the  seat belt warning lamp, see "Warning and indicator lamps in the instrument cluster, seat belt" (▶ page 319).

Rear seat belt status indicator



Display for passengers on the left and right rear seats who are wearing their seat belts (example: vehicles with rear bench seat)

The rear-compartment seat belt status indicator indicates the rear seat on which the belt is fastened. The  symbol in the display indicates a fastened seat belt. If a seat belt is not fastened or if a seat is not occupied, the  symbol is displayed.

The rear-compartment seat belt status indicator appears in the multifunction display for around 30 seconds if:

- you drive off and reach a speed of approximately 10 km/h.
- the rear passengers fasten or unfasten their seat belts while the vehicle is in motion.
- someone gets in or out of the vehicle and the vehicle drives off again.

You can also cancel the rear seat belt status indicator immediately (> page 290).

- i** The status indicator for the rear-compartment seat belts is only available for certain countries.

Belt tensioners, belt force limiters

WARNING

Pyrotechnic seat belt tensioners that have been deployed are no longer operational and are unable to perform their intended protective function. This poses an increased risk of injury or even fatal injury.

Therefore, have pyrotechnic belt tensioners which have been triggered immediately replaced at a qualified specialist workshop.

- !** If the front-passenger seat is not occupied, do not engage the seat belt tongue in the buckle on the front-passenger seat. Otherwise, the belt tensioner could be triggered in the event of an accident.

- i** Vehicles with PRE-SAFE®: belt tensioners that are triggered by an electric motor can be deployed as often as desired and do not need to be replaced.

The front seat belts and the outer seat belts in the rear are equipped with belt tensioners and belt force limiters.

The belt tensioners tighten the seat belts in an accident, pulling them close against the body.

Belt tensioners do not correct incorrect seat positions or incorrectly fastened seat belts.

Belt tensioners do not pull vehicle occupants back towards the backrest.

The belt tensioners can only be activated when:

- the ignition is switched on
- the restraint systems are operational; see " SRS warning lamp" (> page 43)
- the belt tongue is engaged in the buckle on each of the front seat belts

The belt tensioners on the outside seats in the rear compartment are triggered independently of the lock status of the seat belts.

The belt tensioners are triggered depending on the type and severity of an accident:

- in the event of a head-on or rear-end collision if the vehicle decelerates or accelerates rapidly in a longitudinal direction during the initial stages of the impact
- in the event of a side impact if the vehicle decelerates or accelerates rapidly in a lateral direction on the side opposite to the impact
- in certain situations where the vehicle overturns and the system determines that it can provide additional protection

If the airbags are deployed, you will hear a bang, and a small amount of powder may also

be released. Only in rare cases will the bang affect your hearing. The powder that is released generally does not constitute a health hazard and does not indicate that there is a fire in the vehicle. The powder may cause short-term breathing difficulties to persons suffering from asthma or other pulmonary conditions. In order to prevent potential breathing difficulties, you should leave the vehicle as soon as it is safe to do so. You can also open the window to allow fresh air to enter the vehicle interior. The  SRS warning lamp lights up.

If the seat belt is also fitted with a belt force limiter and this is triggered, the force exerted by the seat belt on the vehicle occupant is reduced.

The belt force limiters on the front seats are synchronised with the front airbags, which take on a part of the deceleration force. This results in the load being distributed over a greater area.

Children in the vehicle

Child restraint systems

Important safety notes

WARNING

To reduce the risk of serious or even fatal injury to the child in the event of a sudden change in direction, braking or an accident:

- Children less than 1.50 m tall and under twelve years of age must always be secured in special child restraint systems on a suitable vehicle seat. This is necessary because the seat belts are not designed for children.
- Do not transport children who are secured in rearward-facing child restraint systems on the front-passenger seat. Exception: if the vehicle is equipped with automatic child seat recognition on the front-passenger seat and the child is secured in a child

restraint system with transponders for automatic child seat recognition

- If you secure a forward-facing child restraint system to the front-passenger seat, you must move the front-passenger seat as far back as possible. When doing so, ensure that the shoulder belt strap from the belt outlet on the vehicle is routed towards the front to the shoulder belt guide on the child restraint system. Set the belt height adjustment so that the belt strap is routed towards the front along the bottom.
- Children must never travel sitting on the lap of another occupant. Due to the forces which occur in the event of a sudden change of direction, heavy braking or an accident, it would not be possible to restrain the child. The child could be thrown against parts of the vehicle interior and be seriously or even fatally injured.

WARNING

If the child restraint system is incorrectly fitted on the seat position suitable for this purpose, it cannot perform its intended protective function. In the event of an accident, sharp braking or a sudden change in direction, the child may not be held securely. There is an increased risk of serious or even fatal injuries.

Observe the manufacturer's installation instructions and the correct use for the child restraint system. Make sure that the entire surface of the child restraint system is resting on the seat surface. Never place objects under or behind the child restraint system, e.g. cushions. Only use child restraint systems with the original cover designed for them. Only replace damaged covers with genuine covers.

WARNING

If the child restraint system is fitted incorrectly or is not secured, it can come loose in the event of an accident, heavy braking or a sudden change in direction. The child

restraint system could be thrown about, striking vehicle occupants. There is an increased risk of injury, possibly even fatal.

Always fit child restraint systems properly, even if they are not being used. Make sure that you observe the child restraint system manufacturer's installation instructions.

WARNING

Child restraint systems or their securing systems that have been damaged or subjected to a load in an accident cannot perform their intended protective function. In the event of an accident, sharp braking or a sudden change in direction, the child may not be held securely. There is an increased risk of serious or even fatal injuries.

Immediately replace child restraint systems that have been damaged or subjected to a load in an accident. Have the child restraint securing systems checked in a qualified specialist workshop before fitting a child restraint system again.

WARNING

If children are left unsupervised in the vehicle, they could:

- open the doors, thus endangering other people or road users.
- get out and disrupt traffic.
- operate the vehicle's equipment.

Additionally, children could set the vehicle in motion if, for example, they:

- release the parking brake.
- shift the automatic transmission out of parking position P.
- shift the manual transmission into neutral.
- start the engine.

There is a risk of an accident and injury.

When leaving the vehicle, always take the key with you and lock the vehicle. Never leave children or animals unattended in the vehicle. Always keep the key out of reach of children.

WARNING

If persons (particularly children) are exposed to heat or cold for a prolonged period, there is a risk of serious or even fatal injuries. Never leave persons (particularly children) unattended in the vehicle.

WARNING

If the ICS padded play table is exposed to direct sunlight or heat, parts could heat up. Children could suffer burns on these parts, particularly on metallic parts. There is a risk of injury.

If you and your child leave the vehicle, cover the ICS padded play table so that it is not exposed to direct sunlight and heat. If the ICS padded play table has been exposed to direct sunlight, allow it to cool before securing a child to it. Never leave children unattended in the vehicle.

If a child is travelling in your vehicle, secure the child using a child restraint system which is appropriate to the size, age and weight of the child. In order to correctly secure the child in the child restraint system, always comply with the child restraint system manufacturer's installation instructions. You should preferably fit the restraint system to a suitable rear seat. Make sure that the child is secured for the trip.

Mercedes-Benz recommends that you use the listed child restraint systems (> page 67). You can obtain further information about the correct child restraint system from any Mercedes-Benz Service Centre. You can also secure the child in the integrated child seat (> page 61).

Do not fit a rearward-facing child restraint system on the centre rear seat.

 It is advisable to use Mercedes-Benz care products to clean child restraint systems. You can obtain information about this at any Mercedes-Benz Service Centre.

Child restraint system on the front-passenger seat

WARNING

If the front-passenger front airbag is not disabled:

- a child secured in a child restraint system on the front-passenger seat could be seriously or even fatally injured by the front-passenger airbag deploying. This is especially a risk if the child is in the immediate vicinity of the front-passenger front airbag when it deploys.
- never secure a child on the front-passenger seat in a rearward-facing child restraint system. Only secure a rearward-facing child restraint system on a suitable rear seat.
- and you secure a forward-facing child restraint system to the front-passenger seat, you must move the front-passenger seat as far back as possible. When doing so, ensure that the shoulder belt strap from the belt outlet on the vehicle is routed towards the front to the shoulder belt guide on the child restraint system. Set the belt height adjustment so that the belt strap is routed towards the front along the bottom.

The front-passenger front airbag is not disabled:

- on vehicles without automatic child seat recognition on the front-passenger seat
- on vehicles with automatic child seat recognition on the front-passenger seat, unless a child restraint system with transponders for automatic child seat recognition is fitted to the front-passenger seat
- on vehicles with automatic child seat recognition on the front-passenger seat, if the  PASSENGER AIRBAG OFF indicator lamp is not lit.

To make you aware of this danger, a corresponding warning sticker has been affixed to the side of the dashboard and on both sides of the sun visor on the front-passenger side.

Information about recommended child restraint systems is available at any Mercedes-Benz Service Centre.



Example: warning notice on the front-passenger sun visor



Warning symbol for a rearward-facing child restraint system

NEVER use a rearward facing child restraint system on a seat protected by an ACTIVE FRONT AIRBAG; this could lead to DEATH or SERIOUS INJURY to the child.

Automatic child seat recognition on the front-passenger seat

WARNING

If the  PASSENGER AIRBAG OFF indicator lamp does not light up when the child restraint system is fitted, the front-passenger front airbag has not been disabled. If the front-passenger front airbag deploys, the child could be seriously or even fatally injured.

Proceed as follows:

- do not use a rearward-facing child restraint system on the front-passenger seat.
- fit a rearward-facing child restraint system on a suitable rear seat.

or

- only use a forward-facing child restraint system on the front-passenger seat and move the front-passenger seat as far back as possible. When doing so, ensure that the shoulder belt strap from the belt outlet on the vehicle is routed towards the front to the shoulder belt guide on the child restraint system. Set the belt height adjustment so that the belt strap is routed towards the front along the bottom.
- have the automatic child seat recognition checked at a qualified specialist workshop.

To ensure that the automatic child seat recognition on the front-passenger seat functions/communicates correctly, never place objects, e.g. a cushion, under the child restraint system. The entire base of the child restraint system must always rest on the seat cushion. An incorrectly fitted child restraint system cannot perform its intended protective function in the event of an accident, and could lead to injuries.

WARNING

Electronic devices on the front-passenger seat can affect the function of the automatic child seat recognition, for example:

- laptop
- mobile phone
- transponder cards such as ski passes or access passes

The front-passenger front airbag could deploy unintentionally or not function as intended during an accident. This poses an increased risk of injury or even fatal injury.

Do not place any of the devices mentioned above or similar devices on the front-passenger seat.



If the front-passenger seat of your vehicle does not have automatic child seat recognition, this is indicated by a special sticker. The sticker is affixed to the side of the dashboard on the front-passenger side. The sticker is visible when you open the front-passenger door.

Vehicles without automatic child seat recognition on the front-passenger seat: if you turn the key to position 2 in the ignition lock, the PASSENGER AIRBAG OFF indicator lamp lights up briefly. However, the indicator lamp has no function. It does not indicate that there is automatic child seat recognition on the front-passenger seat.



The sensor system for child restraint systems in the front-passenger seat detects whether a special Mercedes-Benz child seat with a transponder for automatic child seat recognition has been fitted. In this case, PASSENGER AIRBAG OFF indicator lamp ① lights up. The front-passenger front airbag is disabled.

i If the front-passenger front airbag is disabled by the automatic child seat recognition, the following remain enabled on the front-passenger side:

- the sidebag
- the pelvisbag
- the windowbag
- the belt tensioner

ISOFIX child seat securing system for the rear seats

⚠ WARNING

ISOFIX child restraint systems do not offer sufficient protective effect for children whose weight is greater than 22 kg who are secured using the safety belt integrated in the child restraint system. The child could, for example, not be restrained correctly in the event of an accident. This poses an increased risk of injury or even fatal injury.

If the child weighs more than 22 kg, only use ISOFIX child restraint systems with which the child is also secured with the vehicle seat belt. Also secure the child restraint system with the Top Tether belt, if available.

When fitting a child restraint system, be sure to observe the manufacturer's installation instructions and the instructions for correct use of the child restraint system.

⚠ WARNING

The child restraint system cannot perform its protective function if it is not correctly fitted to a suitable vehicle seat. The child cannot be restrained in the event of an accident, heavy braking or sudden changes of direction. The child could be seriously or even fatally injured. For this reason, when securing a child restraint system, always observe the manufacturer's installation instructions and the correct use of the child restraint system.

For safety reasons, on the rear seats use only child restraint systems with an ISOFIX child

seat securing system which have been tested and approved for Mercedes-Benz vehicles.

An incorrectly fitted child restraint system could come loose and seriously or even fatally injure the child or other vehicle occupants. When fitting the child restraint system, always make sure that it is engaged correctly in the ISOFIX securing rings on both sides.

! When fitting the ISOFIX child restraint system, make sure that the seat belt for the centre seat does not get trapped. Otherwise, the seat belt could be damaged.

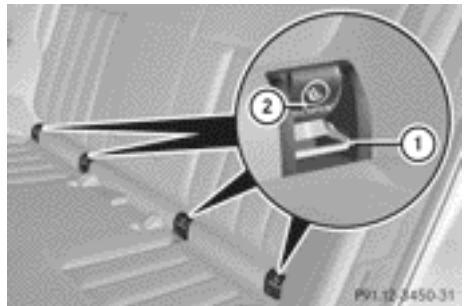

When installing the ISOFIX child restraint system, fold protective caps ② of ISOFIX securing rings ① inwards.

► Install the ISOFIX child restraint system on both ISOFIX securing rings ①. Comply with the child restraint system manufacturer's instructions when installing the ISOFIX child restraint system.

ISOFIX is a standardised securing system for specially designed child restraint systems on the rear seats. The ISOFIX securing rings for two ISOFIX child restraint systems are fitted on the left and right of the rear seats.

Top Tether

Important safety notes

⚠ WARNING

If the rear seat backrests are not locked, they could fold forwards in the event of an accident, heavy braking or sudden changes of direction. As a result, child restraint systems

cannot perform their intended protective function. Rear seat backrests that are not locked can also cause additional injuries, e.g. in the event of an accident. This poses an increased risk of injury or even fatal injury. Always lock rear seat backrests after fitting a Top Tether belt. Observe the lock verification indicator. Adjust the rear seat backrests so that they are positioned vertically.

Top Tether provides an additional connection between the ISOFIX child restraint system secured with ISOFIX and the rear seat. It helps reduce the risk of injury even further.

If the rear seat backrest is not engaged and locked, this will be shown in the multifunction display in the instrument cluster. A warning tone also sounds.

Saloon

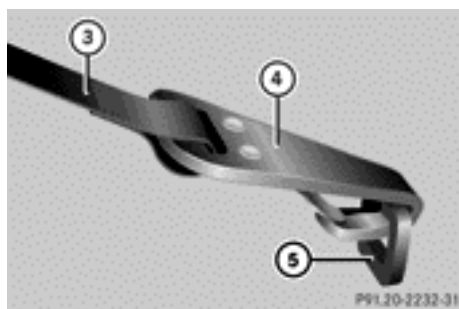
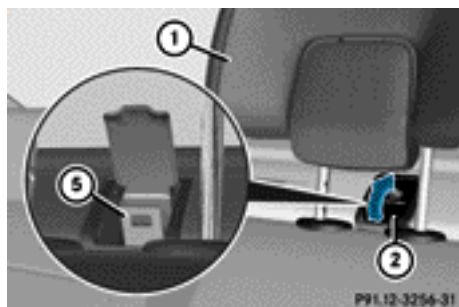

The Top Tether anchorage points are located in the rear compartment behind the head restraints.

- ▶ Move head restraint ① upwards.
- ▶ Fold up cover ② of Top Tether anchorage ⑤.
- ▶ Route Top Tether belt ③ under head restraint ① between the two head restraint bars.
- ▶ Hook Top Tether hook ④ into Top Tether anchorage ⑤.
- ▶ Make sure that Top Tether belt ③ is not twisted.
- ▶ Fold down cover ② of Top Tether anchorage ⑤.
- ▶ Move head restraint ① back down again slightly if necessary (▶ page 118). Make sure that you do not interfere with the correct routing of Top Tether belt ③.
- ▶ Fit the ISOFIX child restraint system with Top Tether. Comply with the manufacturer's installation instructions when doing so. Make sure that Top Tether belt ③ is tight.

Estate

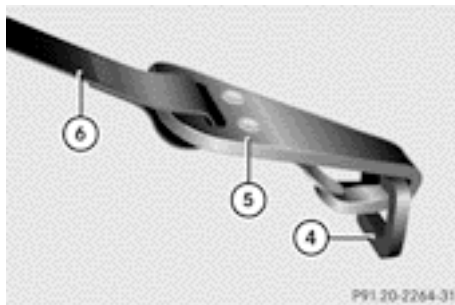
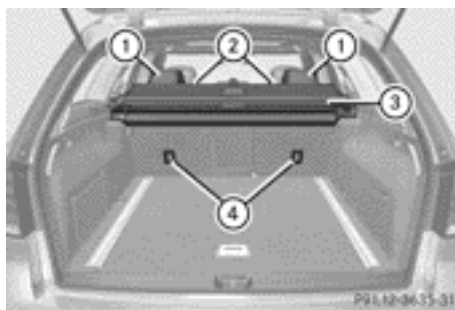

The Top Tether anchorages are attached to the rear of the rear seat backrests.

- ▶ Move head restraint ① upwards.
- ▶ Remove combined luggage cover and net ③ (▷ page 340).
- ▶ Route Top Tether belt ⑥ under head restraint ① between the two head restraint bars.
- ▶ Hook Top Tether hook ⑤ into Top Tether anchorage ④ on the back of rear seat backrest ②.
- ▶ Make sure that Top Tether belt ⑥ is not twisted.
- ▶ Move head restraint ① back down again slightly if necessary (▷ page 118). Make sure that you do not interfere with the correct routing of Top Tether belt ⑥.
- ▶ Fit the ISOFIX child restraint system with Top Tether. Comply with the manufacturer's installation instructions when doing so. Make sure that Top Tether belt ⑥ is tight.
- ▶ Install combined luggage cover and net ③ (▷ page 340).

Integrated child seat (ICS)

Important safety notes

WARNING

If the ICS padded play table has been incorrectly fitted to the integrated child seat, it cannot perform its intended protective function. A child therefore cannot be restrained in the event of an accident, heavy braking or a sudden change of direction. In addition, the ICS padded play table could become loose and be thrown around, endangering vehicle occupants. This poses an increased risk of injury or fatal injury.

Fit the ICS padded play table as described. After fitting the ICS padded play table, make sure that it is secured correctly.

WARNING

If the integrated child seat or the ICS padded play table is modified, damaged or subjected to a load in an accident, it cannot perform its intended protective function. A child therefore cannot be restrained in the event of an accident, heavy braking or a sudden change of direction. This poses an increased risk of injury or even fatal injury.

Immediately replace an integrated child seat or ICS padded play table that has been modified, damaged or subjected to a heavy load as the result of an accident. Only use the ICS padded play table with its original cover or with a cover that has been approved by the manufacturer, and do not use a protective cover.

WARNING

If the ICS padded play table is exposed to direct sunlight or heat, parts could heat up. Children could suffer burns on these parts, particularly on metallic parts. There is a risk of injury.

If you and your child leave the vehicle, cover the ICS padded play table so that it is not exposed to direct sunlight and heat. If the ICS padded play table has been exposed to direct sunlight, allow it to cool before securing a child to it. Never leave children unattended in the vehicle.

The ICS padded play table is only suitable for use together with the folded-out integrated child seat. On the rear seats with an integrated child seat, only use the ICS padded play table that is recommended for Mercedes-Benz vehicles. Only use the ICS padded play table with its original cover. Without the original cover, the official approval is invalidated.

The child seats are integrated into the right and left-hand rear seat cushions. In conjunction with the components listed in the following table, they comply with the legal requirements of ECE R 44.04.

Weight categories	Integrated child seat	ICS padded play table	Side head restraints
Category I: 9 to 18 kg ¹	Folded out	Mandatory	Mandatory
Category II: 15 to 25 kg	Folded out	Not permissible	Mandatory
Category III: 22 to 36 kg	Folded out	Not permissible	Optional

Mercedes-Benz recommends using the integrated child seat for children from the age of 24 months who weigh up to 36 kg.

For children from the age of 24 months who weigh up to 18 kg: an ICS padded play table and a side head restraint which have been specially approved for the integrated child seat must also be used.

Note that children younger than 24 months old require a different child restraint system. When the child seat is occupied, adjust the head restraint so that the centre of the head restraint supports the seat occupant's head at about eye level.

Folding out the child seat

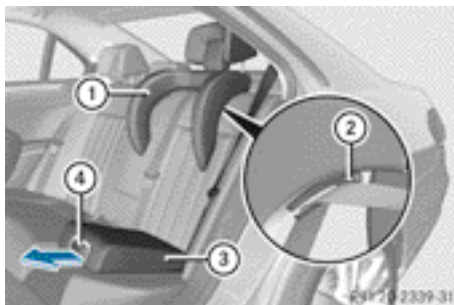

Integrated child seat (example: Saloon)

- ① Side head restraints
- ② Belt guide
- ③ Integrated child seat
- ④ Release handle

- ▶ Pull release handle ④ forwards.
- ▶ Lift integrated child seat ③ and press it back until it engages.

Fastening a child's seat belt

WARNING

To reduce the risk of serious or even fatal injury to the child in the event of a sudden change in direction, braking or an accident:

- the shoulder section of the seat belt must be routed across the centre of the child's shoulder – never across the child's neck – and must fit snugly against the child's chest. The lap section of the seat belt must be routed across the child's pelvis – not across the abdomen – and pulled snug against the child's body. Retighten the belt strap if necessary.
- never secure more than one child at a time in the child restraint system.
- the belt strap must not be trapped or twisted, nor rub against any sharp edges.
- if you have not fitted the side head restraint, the head restraint must always be adjusted correctly when driving with a child in the integrated child seat. If the head restraint

¹ Recommended: 24 months up to 18 kg.

is correctly adjusted, the back of the head is supported by the centre of the head restraint at about eye level.

Observe the installation instructions for the ICS padded play table and the additional warnings and information about risk of injury.

- ▶ Pull the seat belt smoothly from the inertia reel.
- ▶ Engage the seat belt tongue in the belt buckle.
- ▶ If you are using an integrated child seat without the ICS padded play table, make sure that the seat belt:
 - is routed as low as possible across the pelvic area, in front of the hips
 - is tightened across the lap by pulling upwards on the shoulder section of the seat belt
 - is tight and is routed across the centre of the child's shoulder
 - is not twisted and does not pass across the child's neck or under the child's arm
- ▶ Adjust the head restraint if necessary; see (▷ page 118).

Folding in the child seat

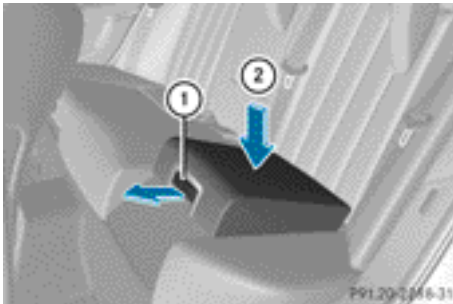

- ▶ Pull release handle ① forwards.
- ▶ Push the centre of the integrated child seat forwards and down ② until it engages.

ICS padded play table for the integrated child seat

Important safety notes

⚠ WARNING

If the ICS padded play table has been incorrectly fitted to the integrated child seat, it cannot perform its intended protective function. A child therefore cannot be restrained in the event of an accident, heavy braking or a sudden change of direction. In addition, the ICS padded play table could become loose and be thrown around, endangering vehicle occupants. This poses an increased risk of injury or fatal injury.

Fit the ICS padded play table as described. After fitting the ICS padded play table, make sure that it is secured correctly.

⚠ WARNING

If the integrated child seat or the ICS padded play table is modified, damaged or subjected to a load in an accident, it cannot perform its intended protective function. A child therefore cannot be restrained in the event of an accident, heavy braking or a sudden change of direction. This poses an increased risk of injury or even fatal injury.

Immediately replace an integrated child seat or ICS padded play table that has been modified, damaged or subjected to a heavy load as the result of an accident. Only use the ICS padded play table with its original cover or with a cover that has been approved by the manufacturer, and do not use a protective cover.

⚠ WARNING

If the ICS padded play table is exposed to direct sunlight or heat, parts could heat up. Children could suffer burns on these parts, particularly on metallic parts. There is a risk of injury.

If you and your child leave the vehicle, cover the ICS padded play table so that it is not exposed to direct sunlight and heat. If the ICS

ICS padded play table has been exposed to direct sunlight, allow it to cool before securing a child to it. Never leave children unattended in the vehicle.

The ICS padded play table is only suitable for use together with the folded-out integrated child seat. On the rear seats with an integrated child seat, only use the ICS padded play table which is recommended for Mercedes-Benz vehicles. Only use the ICS padded play table with its original cover. Without the original cover, the official approval is invalidated. Use the ICS padded play table in accordance with the instructions in table (▷ page 61). You must not use the integrated child seat with ICS padded play table as a direct attachment to a baby car seat for which a body weight of up to 10 kg is permissible.

Fitting the ICS padded play table

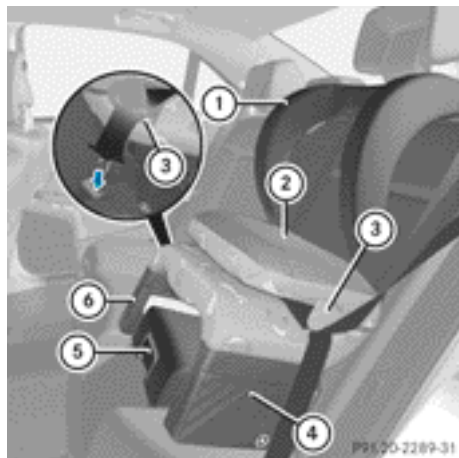

ICS padded play table (example: Saloon)

- ① Side head restraints
- ② ICS padded play table
- ③ Seat belt guide points
- ④ Left leg
- ⑤ Integrated child seat
- ⑥ Right leg

- ▶ Fold out integrated child seat ⑤ (▷ page 61).
- ▶ Place the child on integrated child seat ⑤.
- ▶ Fold both legs ④ and ⑥ down.
- ▶ Place ICS padded play table ② over integrated child seat ⑤.
- ▶ Pull the seat belt smoothly from the inertia reel.
- ▶ Attach the lower and upper sections of the belt in left seat belt guide point ③.
- ▶ Guide both sections of the belt to right seat belt guide point ③ and attach.
- ▶ Engage the seat belt tongue in the belt buckle.
- ▶ Slide ICS padded play table ② close to the child's body.
- ▶ Pull both parts of the belt tight. Make sure that the seat belt is not twisted.
- ▶ Adjust the head restraint if necessary; see (▷ page 118).

Side head restraints for the integrated child seat

WARNING

If the side head restraint has been fitted incorrectly, it cannot perform its intended protective function. A child's head therefore cannot be supported in the event of an accident, heavy braking or a sudden change of direction. In addition, the side head restraint could become loose and be thrown around, endangering vehicle occupants. This poses an increased risk of injury.

Only fasten the side head restraint to the specially designed securing points on the rear head restraint. Only use side head restraints approved by Mercedes-Benz.

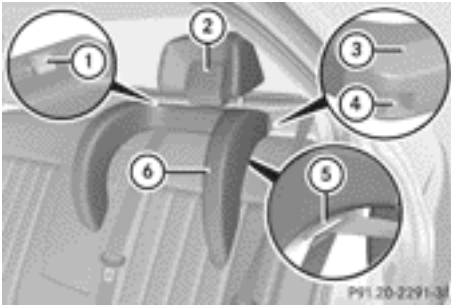

Side head restraint (example: Saloon)

Use the side head restraints in accordance with the instructions in table (▷ page 61).

Fitting side head restraints

- ▶ Slide head restraint ② upwards and position it upright.
- ▶ Slide side head restraints ⑥ from the front to the centre of both head restraint bars until they engage.
Right- and left-hand lock verification indicators ③ must be folded in. The red surfaces are no longer visible.
- ▶ Make sure that side head restraint ⑥ is engaged in both head restraint bars.
- ▶ Slide head restraint ② downwards (▷ page 118) until it rests on the upper edge of side head restraints ⑥.
- ▶ Guide the seat belt through seat belt guide ⑤ on the door side on side head restraint ⑥.
- ▶ Secure the child (▷ page 62).

Removing the side head restraints

- ▶ Remove the seat belt from seat belt guide ⑤.
- ▶ Move head restraint ② upwards.
- ▶ Press left or right release button ④ and pull side head restraint ⑥ forward to remove it.
Left and right lock verification indicators ① fold out briefly.
- ▶ Adjust head restraint ② (▷ page 118).

- ▶ **i** Should a side head restraint be required for the second integrated child seat, this can be ordered at any Mercedes-Benz Service Centre.

Storing the ICS padded play table and the side head restraint

On vehicles with a TIREFIT kit, for example, you can store the side head restraints in the stowage compartment under the boot floor (▷ page 345) or luggage compartment floor (▷ page 346).

Suitable positioning of the child restraint systems

Only child restraint systems which are approved in accordance with the ECE standard ECE R44 are permitted for use in the vehicle.

- ▶ **Fitting a child restraint system on the front-passenger seat:** move the front-passenger seat to its lowest, rearmost position.
- ▶ Move the belt height adjustment to the lowest position.

Suitability of the seats for attaching belted child restraint systems

Key to the letters used in the following table:

- X Seat which is unsuitable for children in this weight category.
- U Suitable for child restraint systems in the "Universal" category that are approved for use in this weight category.
- L Suitable for child restraint systems as recommended; see the following table of "Recommended child restraint systems" (▷ page 67).

Front-passenger seat

Weight categories	Front-passenger front air-bag is not disabled	Front-passenger front air-bag is disabled
Category 0: up to 10 kg	X	L
Category 0+: up to 13 kg	X	L
Category I: 9 to 18 kg	L	L
Category II: 15 to 25 kg	L	L
Category III: 22 to 36 kg	L	L

Vehicles with automatic child seat recognition in the front-passenger seat: a "Universal" category child restraint system with a transponder for automatic child seat recognition must be fitted when the front-passenger front airbag is disabled. The PASSENGER AIRBAG OFF indicator lamp must be lit.

Rear seats

Weight categories	Left, right	Centre
Category 0: up to 10 kg	U	U
Category 0+: up to 13 kg	U	U
Category I: 9 to 18 kg	U	U

Weight categories	Left, right	Centre
Category II: 15 to 25 kg	U	U
Category III: 22 to 36 kg	U	U

i Vehicles with a folding bench seat in the load compartment (Estate): information on child restraint systems on the folding bench seat can be obtained at any Mercedes-Benz Service Centre.



Example: approval label on the child restraint system

"Universal" category child restraint systems can be recognised by their orange approval label and the text "Universal".

"Universal" category child restraint systems can be used on the seats indicated with U or IUF according to the tables "Suitability of the seats for attaching belted child restraint systems" or "Suitability of the seats for attaching an ISOFIX child restraint system".

Semi-universal child restraint systems are indicated by the text "semi-universal" on the approval label. These can be used if the vehicle and the seat are listed in the child restraint system manufacturer's vehicle model list. For more information, contact the child restraint system manufacturer or visit their website.

Suitability of the seats for attaching ISOFIX child restraint systems

Key to the letters used in the following table:

- X ISOFIX position that is not suitable for ISOFIX child restraint systems in this weight category and/or size category.
- IUF Suitable for forward-facing ISOFIX child restraint systems that belong to the "Universal" category which are approved for use in this weight category.
- IL Suitable for ISOFIX child restraint systems as recommended; see the following table of "Recommended child restraint systems" (▷ page 67).

The manufacturer will also recommend a suitable ISOFIX child restraint system. For this, your vehicle and the seat must be listed in the child restraint system manufacturer's model list. For more information, contact the child restraint system manufacturer or visit their website.

Carry-cot weight category

Size category	Equipment	Rear seat, left and right
F	ISO/L1	X
G	ISO/L2	X

Weight category 0: up to 10 kg up to approximately 6 months

Size category	Equipment	Rear seat, left and right
E	ISO/R1	IL

Weight category 0+: up to 13 kg up to approximately 15 months

Size category	Equipment	Rear seat, left and right
E	ISO/R1	IL
D	ISO/R2	IL
C	ISO/R3	IL

Weight category I: 9 to 18 kg approximately 9 months to 4 years

Size category	Equipment	Rear seat, left and right
D	ISO/R2	IL
C	ISO/R3	IL
B	ISO/F2	IUF
B1	ISO/F2X	IUF
A	ISO/F3	IUF

Recommended child restraint systems

When installing a child restraint system on the front-passenger seat:

- ▶ Move the front-passenger seat to its lowest and rearmost position.

Weight category 0: up to 10 kg; up to approximately 6 months

Manufacturer	Britax Römer
Type	BABY SAFE plus
Approval number (E1 ...)	03 301146 04 301146
Order number (A 000 ...)	970 10 00
Automatic child seat recognition	Yes

Weight category 0+: up to 13 kg; up to approximately 15 months

Manufacturer	Britax Römer
Type	BABY SAFE plus
Approval number (E1 ...)	03 301146 04 301146
Order number (A 000 ...)	970 10 00
Automatic child seat recognition	Yes

Weight category I: 9 to 18 kg; approximately 9 months to 4 years

Manufacturer	Britax Römer	Britax Römer
Type	DUO plus	DUO plus
Approval number (E1 ...)	03 301133 04 301133	03 301133 04 301133
Order number (A 000 ...)	970 11 00	970 16 00
Automatic child seat recognition	Yes	No

Weight category II/III: 15 to 36 kg; approximately 4 to 12 years

Manufacturer	Britax Römer	Britax Römer
Type	KID	KID
Approval number (E1 ...)	03 301148 04 301148	03 301148 04 301148

Order number (A 000 ...)	970 12 00	970 17 00
Automatic child seat recognition	Yes	No

Manufacturer	Britax Römer	Britax Römer
Type	KIDFIX	KIDFIX
Approval number (E1 ...)	04 301198	04 301198
Order number (A 000 ...)	970 18 00	970 19 00
Automatic child seat recognition	Yes	No

Suggested "Universal" category ISOFIX child restraint systems:**Carry-cot weight category**

Size categories	F, G
Manufacturer	-
Type	-
Approval number (E1 ...)	-
Order number	-
Automatic child seat recognition	-

Category 0: up to 10 kg

Size category	E
Manufacturer	-
Type	-

Approval number (E1 ...)	-
Order number	-
Automatic child seat recognition	-

Order number	A 000 970 11 00
Automatic child seat recognition	Yes

Category 0+: up to 13 kg



Size categories	E	D, C
Manufacturer	Britax Römer	-
Type	BABY SAFE ISO-FIX PLUS	-
Approval number (E1 ...)	04 301 146	-
Order number	B6 6 86 8224	-
Automatic child seat recognition	No	-

Category I: 9 to 18 kg

Size categories	D, C, B, A
Manufacturer	-
Type	-
Approval number (E1 ...)	-
Order number	-
Automatic child seat recognition	-

Size category	B1
Manufacturer	Britax Römer
Type	DUO plus
Approval number (E1 ...)	03 301 133 04 301 133

Problems with automatic child seat recognition

Problem	Possible causes/consequences and ► Solutions
<p>The PASSENGER AIR-BAG OFF indicator lamp on the centre console is lit.</p>	<p>A special Mercedes-Benz child restraint system with a transponder for automatic child seat recognition has been fitted to the front-passenger seat. The front-passenger front airbag has therefore been disabled as desired.</p> <p> WARNING</p> <p>There is no child restraint system fitted to the front-passenger seat. Automatic child seat recognition is malfunctioning.</p> <p>It is also possible that the  SRS warning lamp lights up and/or the PASSENGER AIRBAG OFF indicator lamp does not light up briefly when you switch the ignition on.</p> <p>There is a risk of injury.</p> <p>► Remove electronic equipment from the front-passenger seat, e.g.:</p> <ul style="list-style-type: none"> • laptop • mobile phone • cards with transponders, such as ski passes or access cards <p>If the PASSENGER AIRBAG OFF indicator lamp is still lit:</p> <p>► Visit a qualified specialist workshop.</p>

Child-proof locks

Important safety notes

WARNING

If children are left unsupervised in the vehicle, they could:

- open the doors, thus endangering other people or road users.
- get out and disrupt traffic.
- operate the vehicle's equipment.

Additionally, children could set the vehicle in motion if, for example, they:

- release the parking brake.
- shift the automatic transmission out of parking position P.
- shift the manual transmission into neutral.
- start the engine.

There is a risk of an accident and injury.

When leaving the vehicle, always take the key with you and lock the vehicle. Never leave children or animals unattended in the vehicle. Always keep the key out of reach of children.

WARNING

If persons (particularly children) are exposed to heat or cold for a prolonged period, there is a risk of serious or even fatal injuries. Never leave persons (particularly children) unattended in the vehicle.

⚠ WARNING

If children are travelling in the vehicle, they could:

- open doors, thus endangering other people or road users
- exit the vehicle and be caught by oncoming traffic
- operate vehicle equipment and become trapped, for example

There is a risk of an accident and injury.

Always activate the child-proof locks and override feature if children are travelling in the vehicle. When leaving the vehicle, always take the key with you and lock the vehicle. Never leave children unattended in the vehicle.

You can activate the following child-proof locks:

- rear doors (▷ page 71)
- rear side windows (▷ page 71)

Child-proof locks for the rear doors

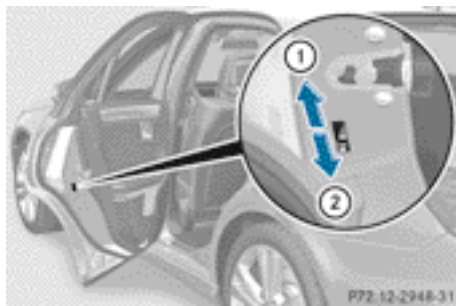

Rear door child-proof lock (example: Saloon)

You secure each door individually with the child-proof locks on the rear doors. A door secured with a child-proof lock cannot be opened from inside the vehicle. When the vehicle is unlocked, the door can be opened from the outside.

- ▶ **To activate:** press the child-proof lock lever up in the direction of arrow ①.
- ▶ Make sure that the child-proof locks are working properly.
- ▶ **To deactivate:** press the child-proof lock lever down in the direction of arrow ②.

Override feature for the rear side windows



- ▶ **To activate/deactivate:** press button ②. If indicator lamp ① is lit, operation of the rear side windows is disabled. Operation is only possible using the switches in the driver's door. If indicator lamp ① is off, operation is possible using the switches in the rear compartment.

Driving safety systems

Driving safety systems overview

In this section, you will find information about the following driving safety systems:

- ABS (**A**nti-**l**ock **B**raking **S**ystem) (▷ page 72)
- BAS (**B**rake **A**ssist **S**ystem) (▷ page 73)
- BAS PLUS (**B**rake **A**ssist **S**ystem **P**LUS) with Cross-Traffic Assist (▷ page 73)
- COLLISION PREVENTION ASSIST (adaptive Brake Assist and distance warning function) (▷ page 75)
- Adaptive brake lamps (▷ page 77)

- ESP® (Electronic Stability Program) (▷ page 77)
- EBD (electronic brake force distribution) (▷ page 80)
- ADAPTIVE BRAKE (▷ page 81)
- PRE-SAFE® Brake (▷ page 81)

Important safety notes

If you fail to adapt your driving style or if you are inattentive, the driving safety systems can neither reduce the risk of an accident nor override the laws of physics. Driving safety systems are merely aids designed to assist driving. You are responsible for the distance to the vehicle in front, for vehicle speed and for braking in good time. Always adapt your driving style to suit the prevailing road, weather and traffic conditions and maintain a safe distance from the vehicle in front. Drive carefully.

- i** The driving safety systems described only work as effectively as possible when there is adequate contact between the tyres and the road surface. Please pay special attention to the notes on tyres, recommended minimum tyre tread depths etc. (▷ page 404).

In wintry driving conditions, always use winter tyres (M+S tyres) and, if necessary, snow chains. Only in this way will the driving safety systems described in this section work as effectively as possible.

ABS (Anti-lock Braking System)

General notes

ABS regulates brake pressure in such a way that the wheels do not lock when you brake. This allows you to continue steering the vehicle when braking.

The yellow  ABS warning lamp in the instrument cluster lights up when the ignition

is switched on. It goes out when the engine is running.

Important safety notes

- i** Observe the "Important safety notes" section (▷ page 72).

WARNING

If ABS is faulty, the wheels could lock when braking. The steerability and braking characteristics may be severely impaired. Additionally, further driving safety systems are deactivated. There is an increased danger of skidding and accidents.

Drive on carefully. Have ABS checked immediately at a qualified specialist workshop.

If ABS is malfunctioning, other systems, including driving safety systems, will also become inoperative. Observe the information on the ABS warning lamp (▷ page 321) and display messages which may be shown in the instrument cluster (▷ page 291).

ABS works from a speed of about 8 km/h upwards, regardless of road-surface conditions. ABS works on slippery surfaces, even when you only brake gently.

Braking

- ▶ **If ABS intervenes:** continue to depress the brake pedal with force until the braking situation is over.
- ▶ **To make a full brake application:** depress the brake pedal with full force.

If ABS intervenes when braking, you will feel a pulsing in the brake pedal.

The pulsating brake pedal can be an indication of hazardous road conditions, and functions as a reminder to take extra care while driving.

BAS (Brake Assist)

General notes

BAS operates in emergency braking situations. If you depress the brake pedal quickly, BAS automatically boosts the braking force, thus shortening the stopping distance.

Important safety notes

- Observe the "Important safety notes" section (▷ page 72).

WARNING

If BAS is malfunctioning, the braking distance in an emergency braking situation is increased. There is a risk of accident.

In an emergency braking situation, depress the brake pedal with full force. ABS prevents the wheels from locking.

Braking

- Keep the brake pedal depressed firmly until the emergency braking situation is over. ABS prevents the wheels from locking.

The brakes will function as usual once you release the brake pedal. BAS is deactivated.

BAS PLUS (Brake Assist PLUS) with Cross-Traffic Assist

General notes

- Observe the "Important safety notes" section (▷ page 72).

BAS PLUS is only available on vehicles with the Driving Assistance package.

For BAS PLUS to assist you when driving, the radar sensor system and the camera system must be operational.

With the help of a sensor system and a camera system, BAS PLUS can detect obstacles:

- that are in the path of your vehicle for an extended period of time.
- that cross the path of your vehicle.

In addition, pedestrians in the path of your vehicle can be detected.

BAS PLUS detects pedestrians using typical characteristics such as the body contours and posture of a person standing upright.

If the radar sensor system or the camera system is malfunctioning, BAS PLUS functions are restricted or no longer available. The brake system is still available with complete brake boosting effect and BAS.

- Observe the restrictions described in the "Important safety notes" section (▷ page 73).

BAS PLUS can help you to minimise the risk of a collision with a vehicle or a pedestrian and reduce the effects of such a collision. If BAS PLUS detects a danger of collision, you are assisted when braking.

Important safety notes

WARNING

BAS PLUS cannot always clearly identify objects and complex traffic situations.

In such cases, BAS PLUS may:

- intervene unnecessarily
- not intervene

There is a risk of an accident.

Always pay careful attention to the traffic situation and be ready to brake. Terminate the intervention in a non-critical driving situation.

WARNING

BAS PLUS does not react:

- to small people, e.g. children
- to animals
- to oncoming vehicles
- when cornering

As a result, BAS PLUS may not intervene in all critical situations. There is a risk of an accident.

Always pay careful attention to the traffic situation and be ready to brake.

In the event of snowfall or heavy rain, recognition can be impaired.

Recognition by the radar sensor system is also impaired in the event of:

- dirt on the sensors or the sensors are obscured
- interference by other radar sources
- strong radar reflections, for example, in multi-storey car parks
- a narrow vehicle travelling in front, e.g. a motorcycle
- a vehicle travelling in front on a different line
- vehicles quickly moving into the radar sensor system detection range

Recognition by the camera system is also impaired in the event of:

- dirt on the camera or if the camera is covered
- there is glare on the camera system, e.g. from the sun being low in the sky
- darkness
- if:
 - pedestrians move quickly, e.g. into the path of the vehicle
 - the camera system no longer recognises a pedestrian as a person due to special clothing or other objects
 - a pedestrian is concealed by other objects
 - the typical outline of a person is not distinguishable from the background.

Following damage to the front end of the vehicle, have the radar sensor settings and operation checked at a qualified specialist workshop. This also applies to collisions at slow speeds where there is no visible damage to the front of the vehicle.

Following damage to the windscreen, have the configuration and operation of the camera system checked at a qualified specialist workshop.

Function

To avoid a collision, BAS PLUS calculates the brake force necessary if:

- you approach an obstacle, and
- BAS PLUS has detected a risk of collision

When driving at a speed under 30 km/h: if you depress the brake pedal, BAS PLUS is activated. Braking assistance from BAS PLUS is carried out at the last possible moment.

When driving at a speed above 30 km/h: if you depress the brake pedal sharply, BAS PLUS automatically increases the brake pressure to a degree suited to the traffic situation. BAS PLUS provides braking assistance in hazardous situations with vehicles in front within a speed range between 7 km/h and 250 km/h.

At speeds of up to approximately 70 km/h, BAS PLUS reacts to:

- stationary objects in the path of your vehicle, e.g. stopped or parked vehicles
- pedestrians in the path of your vehicle
- objects crossing your path

i If BAS PLUS demands particularly high braking force, anticipatory occupant protection measures (PRE-SAFE®) are activated simultaneously.

► Keep the brake pedal depressed until the emergency braking situation is over. ABS prevents the wheels from locking.

BAS PLUS is deactivated and the brakes function as usual, if:

- you release the brake pedal
- there is no longer a risk of collision
- no obstacle is detected in front of your vehicle
- you depress the accelerator pedal
- you activate kickdown

COLLISION PREVENTION ASSIST

General notes

COLLISION PREVENTION ASSIST consists of the distance warning function and adaptive Brake Assist, which are described in the following section.

Distance warning function

Important safety notes

- ❗ Observe the "Important safety notes" section (▷ page 72).

WARNING

The distance warning function does not react:

- to people or animals
- to oncoming vehicles
- to crossing traffic
- when cornering

Thus, the distance warning function cannot provide a warning in all critical situations. There is a risk of an accident.

Always pay careful attention to the traffic situation and be ready to brake.

WARNING

The distance warning function cannot always clearly identify objects and complex traffic situations.

In such cases, the distance warning function may:

- give an unnecessary warning
- not give a warning

There is a risk of an accident.

Always pay careful attention to the traffic situation; do not rely on the distance warning function alone.



Function

- ▶ **To activate/deactivate:** activate or deactivate the distance warning function in the on-board computer (▷ page 279).

If the distance warning function is not activated, the  symbol appears in the assistance graphics display.

The distance warning function can help you to minimise the risk of a front-end collision with a vehicle ahead or reduce the effects of such a collision. If the distance warning function detects that there is a risk of a collision, you will be warned visually and acoustically. Without your intervention, the distance warning function cannot prevent a collision.

The distance warning function issues a warning at speeds:

- of around 30 km/h or more, if, over several seconds, the distance maintained to the vehicle travelling in front is insufficient. The  distance warning lamp then lights up in the instrument cluster.
- of around 7 km/h or higher, if you very quickly approach a vehicle in front. An intermittent warning tone will then sound and the  distance warning lamp will light up in the instrument cluster.

▶ Brake immediately in order to increase the distance from the vehicle in front.

or

▶ Take evasive action provided it is safe to do so.

Due to the nature of the system, particularly complicated but non-critical driving conditions may also cause the system to display a warning.

With the help of the radar sensor system, the distance warning function can detect obstacles that are in the path of your vehicle for an extended period of time.

From a speed of around 70 km/h, the distance warning function can also react to stationary obstacles, such as stopped or parked vehicles.

If you approach an obstacle and the distance warning function detects a risk of a collision, the system will alert you both visually and acoustically.

In particular, the detection of obstacles can be impaired in the case of:

- dirt on the sensors or the sensors are obscured
- snow or heavy rain
- interference by other radar sources
- strong radar reflections, for example, in multi-storey car parks
- a narrow vehicle travelling in front, e.g. a motorcycle
- a vehicle travelling in front on a different line

Following damage to the front end of the vehicle, have the configuration and operation of the radar sensor checked at a qualified specialist workshop. This also applies to collisions at slow speeds where there is no visible damage to the front of the vehicle.

Adaptive Brake Assist

- i** Observe the "Important safety notes" section (▷ page 72).

WARNING

Adaptive Brake Assist cannot always clearly identify objects and complex traffic situations.

In such cases, Adaptive Brake Assist may:

- intervene unnecessarily
- not intervene

There is a risk of an accident.

Always pay careful attention to the traffic situation and be ready to brake. Terminate the intervention in a non-critical driving situation.

WARNING

Adaptive Brake Assist does not react:

- to people or animals
- to oncoming vehicles
- to crossing traffic
- to stationary obstacles
- when cornering

As a result, Adaptive Brake Assist may not intervene in all critical conditions. There is a risk of an accident.

Always pay careful attention to the traffic situation and be ready to brake.

Adaptive Brake Assist aids you in braking during hazardous situations at speeds above 7 km/h and uses the radar sensor system to evaluate the traffic situation.

With the help of adaptive Brake Assist, the distance warning signal can detect obstacles that are in the path of your vehicle for an extended period of time.

Should you approach an obstacle and adaptive Brake Assist has detected a risk of collision, adaptive Brake Assist calculates the braking force necessary to avoid a collision. Should you apply the brakes forcefully, adaptive Brake Assist will automatically increase the braking force to a level suitable for the traffic conditions.

- ▶ Keep the brake pedal depressed until the emergency braking situation is over. ABS prevents the wheels from locking.

The brakes will work normally again if:

- you release the brake pedal
- there is no longer any danger of a collision
- no obstacle is detected in front of your vehicle

Adaptive Brake Assist is then deactivated.

Vehicles with PRE-SAFE®: if adaptive Brake Assist requires particularly high brake pressure, preventive passenger protection measures (PRE-SAFE®) are deployed simultaneously.

Up to vehicle speeds of around 250 km/h, adaptive Brake Assist is capable of reacting to moving objects that have already been recognised as such at least once over the period of observation. Adaptive Brake Assist does not react to stationary obstacles.

If adaptive Brake Assist is not available due to a malfunction in the radar sensor system,

the brake system remains available with full brake boosting effect and BAS.

In particular, the detection of obstacles can be impaired if there is:

- dirt on the sensors or the sensors are obscured
- snow or heavy rain
- interference by other radar sources
- strong radar reflections, for example, in multi-storey car parks
- a narrow vehicle travelling in front, e.g. a motorcycle
- a vehicle travelling in front on a different line

Following damage to the front end of the vehicle, have the configuration and operation of the radar sensor checked at a qualified specialist workshop. This also applies to collisions at slow speeds where there is no visible damage to the front of the vehicle.

Adaptive brake lamps

If you brake sharply from a speed of more than 50 km/h or if braking is assisted by BAS or BAS PLUS, the brake lamps flash rapidly. In this way, traffic travelling behind you is warned in an even more noticeable manner.

If you brake sharply from a speed of more than 70 km/h to a standstill, the hazard warning lamps are activated automatically. If the brakes are applied again, the brake lamps light up continuously. The hazard warning lamps switch off automatically if you travel faster than 10 km/h. You can also switch off the hazard warning lamps using the hazard warning button (▷ page 140).

ESP® (Electronic Stability Program)

General notes

- ❗ Observe the "Important safety notes" section (▷ page 72).

ESP® monitors driving stability and traction, i.e. power transmission between the tyres and the road surface.

If ESP® detects that the vehicle is deviating from the direction desired by the driver, one or more wheels are braked to stabilise the vehicle. The engine output is also modified to keep the vehicle on the desired course within physical limits. ESP® assists the driver when pulling away on wet or slippery roads. ESP® can also stabilise the vehicle during braking.

ETS/4ETS (Electronic Traction System)

ETS/4ETS traction control is part of ESP®.

Traction control brakes the drive wheels individually if they spin. This enables you to pull away and accelerate on slippery surfaces, for example if the road surface is slippery on one side. In addition, more drive torque is transferred to the wheel or wheels with traction.

Traction control remains active if you deactivate ESP®.

Important safety notes

- ❗ Observe the "Important safety notes" section (▷ page 72).

⚠ WARNING

If ESP® is malfunctioning, ESP® is unable to stabilise the vehicle. In addition, other driving safety systems are switched off. This increases the risk of skidding and an accident.

Drive on carefully. Have ESP® checked at a qualified specialist workshop.

- ❗ Vehicles with 4MATIC: switch off the ignition when the parking brake is being tested using a dynamometer.



Application of the brakes by ESP® may otherwise destroy the brake system.

- ❗ Vehicles with 4MATIC: function or performance tests may only be carried out on a 2-axle dynamometer. Before operating the vehicle on such a dynamometer, please consult a qualified specialist workshop.

You could otherwise damage the drive train or the brake system.

Vehicles without 4MATIC: when towing your vehicle with the rear axle raised, it is important that you observe the notes on ESP® (▷ page 398).

ESP® is deactivated if the  warning lamp in the instrument cluster lights up continuously when the engine is running.

If the  warning lamp and the  warning lamp are lit continuously, ESP® is not available due to a malfunction.

Observe the information on warning lamps (▷ page 322) and display messages which may be shown in the instrument cluster (▷ page 291).

- i** Only use wheels with the recommended tyre sizes. Only then will ESP® function properly.

Characteristics of ESP®

General notes

If the  ESP warning lamp goes out before beginning the journey, ESP® is automatically active.

If ESP® intervenes, the  ESP® warning lamp flashes in the instrument cluster.

If ESP® intervenes:

- ▶ Do not deactivate ESP® under any circumstances.
- ▶ When pulling away, only depress the accelerator pedal as far as is necessary.
- ▶ Adapt your driving style to suit the prevailing road and weather conditions.

ECO start/stop function

The ECO start/stop function switches the engine off automatically if the vehicle stops moving. When pulling away again, the engine starts automatically. ESP® remains in its previously selected status. **Example:** if ESP® was deactivated before the engine was

switched off, ESP® remains deactivated when the engine is switched on again.

Deactivating/activating ESP® (except AMG vehicles)

Important safety notes

You can select between the following statuses of ESP:

- ESP® is activated.
- ESP® is deactivated.

WARNING

If you deactivate ESP®, ESP® no longer stabilises the vehicle. There is an increased risk of skidding and an accident.

Only deactivate ESP® in the situations described in the following.

It may be best to deactivate ESP® in the following situations:

- when using snow chains
- in deep snow
- on sand or gravel

- i** Activate ESP® as soon as the situations described above no longer apply. ESP® will otherwise not be able to stabilise the vehicle if the vehicle starts to skid or a wheel starts to spin.

Deactivating/activating ESP®

- ▶ **To deactivate:**(▷ page 278).

The  ESP® OFF warning lamp in the instrument cluster lights up.

- ▶ **To activate:**(▷ page 278).

The  ESP® OFF warning lamp in the instrument cluster goes out.

Characteristics when ESP® is deactivated

If ESP® is deactivated and one or more wheels start to spin, the  ESP® warning lamp in the instrument cluster flashes. In such situations, ESP® will not stabilise the vehicle.

If you deactivate ESP®:

- ESP® no longer improves driving stability.
- engine torque is no longer limited and the drive wheels are able to spin.

The spinning of the wheels results in a cutting action for better traction on loose surfaces.

- traction control is still activated.
- ESP® still provides support when you brake.

Deactivating/activating ESP® (AMG vehicles)

Important safety notes

You can select between the following statuses of ESP:

- ESP® is activated
- SPORT handling mode is activated
- ESP® is deactivated

WARNING

When SPORT handling mode is activated, there is a greater risk of skidding and accidents.

Only activate SPORT handling mode in the situations described in the following.

WARNING

If you deactivate ESP®, ESP® no longer stabilises the vehicle. There is an increased risk of skidding and an accident.

Only deactivate ESP® in the situations described in the following.

It may be best to activate SPORT handling mode in the following situations:

- when using snow chains
- in deep snow
- on sand or gravel
- on specially designated roads when the vehicle's own oversteering and understeering characteristics are desired

Driving in SPORT handling mode or without ESP® requires an extremely qualified and experienced driver.

- ① Activate ESP® as soon as the situations described above no longer apply. ESP® will otherwise not be able to stabilise the vehicle if the vehicle starts to skid or a wheel starts to spin.

Deactivating/activating ESP®



- ▶ **To activate SPORT handling mode:** briefly press button ①.

The **SPORT** handling mode warning lamp in the instrument cluster lights up. The **SPORT handling mode** message appears in the multifunction display.

- ▶ **To deactivate SPORT handling mode:** briefly press button ①.

The **SPORT** handling mode warning lamp in the instrument cluster goes out.

- ▶ **To deactivate ESP®:** press button ① until the **ESP OFF** warning lamp lights up in the instrument cluster.

The **ESP OFF** message appears in the multifunction display.

- ▶ **To activate ESP®:** briefly press button ①.

The **ESP OFF** warning lamp in the instrument cluster goes out. The **ESP ON** message appears in the multifunction display.

Characteristics of activated SPORT handling mode

If SPORT handling mode is activated and one or more wheels start to spin, the  ESP® warning lamp in the instrument cluster flashes. ESP® only stabilises the vehicle to a limited degree.

When SPORT handling mode is activated:

- ESP® only improves driving stability to a limited degree.
- traction control is still activated.
- engine torque is restricted to a limited degree and the drive wheels are able to spin.

The spinning of the wheels results in a cutting action for better traction on loose surfaces.

- ESP® still provides support when you brake.

Characteristics when ESP® is deactivated

If ESP® is deactivated and one or more wheels start to spin, the  ESP® warning lamp in the instrument cluster does not flash. In such situations, ESP® will not stabilise the vehicle.

If you deactivate ESP®:

- ESP® no longer improves driving stability.
- engine torque is restricted to a limited degree and the drive wheels are able to spin.

The spinning of the wheels results in a cutting action for better traction on loose surfaces.

- traction control is still activated.
- PRE-SAFE® is no longer available; nor is it activated if you brake firmly with assistance from ESP®.
- PRE-SAFE® Brake is no longer available; it is also not activated if you brake firmly with assistance from ESP®.
- ESP® still provides support when you brake.

ESP® trailer stabilisation

WARNING

If road and weather conditions are poor, trailer stabilisation will not be able to prevent the vehicle/trailer combination from swerving. Trailers with a high centre of gravity can tip over before ESP® can detect this. There is a risk of an accident.

Always adapt your driving style to the prevailing road and weather conditions.

If your vehicle/trailer combination begins to lurch, you can only stabilise the vehicle/trailer combination by depressing the brake firmly.

In this situation, ESP® assists you and can detect if the vehicle/trailer combination begins to lurch. ESP® slows the vehicle down by braking and limiting the engine output until the vehicle/trailer combination has stabilised.

Trailer stabilisation is active above speeds of about 65 km/h.

Trailer stabilisation does not work if ESP® is deactivated or disabled because of a malfunction.

EBD (electronic brake force distribution)

General notes

EBD monitors and controls the brake pressure on the rear wheels to improve driving stability while braking.

Important safety notes

- ① Observe the "Important safety notes" section for driving safety systems (▷ page 72).

WARNING

If EBD has malfunctioned, the rear wheels can still lock, e.g. under full braking. This increases the risk of skidding and an accident.

You should therefore adapt your driving style to the different handling characteristics. Have the brake system checked at a qualified specialist workshop.

Observe information regarding indicator and warning lamps (▷ page 321) as well as display messages (▷ page 293).

ADAPTIVE BRAKE

ADAPTIVE BRAKE enhances braking safety and offers increased braking comfort. In addition to the braking function, ADAPTIVE BRAKE also has the HOLD function (▷ page 221) and hill start assist (▷ page 180).

PRE-SAFE® Brake

General notes

i Observe the "Important safety notes" section (▷ page 72).

PRE-SAFE® Brake is only available for vehicles with the Driving Assistance package.

For PRE-SAFE® Brake to assist you when driving, the radar sensor system and the camera system must be switched on and be operational.

With the help of the radar sensor system and the camera system, PRE-SAFE® Brake can detect obstacles that are in front of your vehicle for an extended period of time.

In addition, pedestrians in the path of your vehicle can be detected.

PRE-SAFE® Brake detects pedestrians using typical characteristics such as the body contours and posture of a person standing upright.

i Observe the restrictions described in the "Important safety notes" section (▷ page 81).

PRE-SAFE® Brake can help you to minimise the risk of a collision with a vehicle ahead or a pedestrian, and reduce the effects of such

a collision. If PRE-SAFE® Brake has detected a risk of collision, you will be warned visually and acoustically as well as by automatic braking.

Important safety notes

WARNING

PRE-SAFE® Brake will initially brake your vehicle by a partial application of the brakes if a danger of collision is detected. There may be a collision unless you brake yourself. Even after subsequent full application of the brakes a collision cannot always be avoided, particularly when approaching at too high a speed. There is a risk of an accident.

Always apply the brakes yourself and try to take evasive action, provided it is safe to do so.

WARNING

PRE-SAFE® Brake cannot always clearly identify objects and complex traffic conditions.

In these cases, PRE-SAFE® Brake may:

- give an unnecessary warning and then brake the vehicle
- neither give a warning nor intervene

There is a risk of an accident.

Always pay particular attention to the traffic situation and be ready to brake, especially if PRE-SAFE® Brake warns you. Terminate the intervention in a non-critical driving situation.

In order to maintain the appropriate distance to the vehicle in front and thus prevent a collision, you must apply the brakes yourself.

WARNING

PRE-SAFE® Brake does not react:

- to small people, e.g. children
- to animals
- to oncoming vehicles
- to crossing traffic
- when cornering

As a result, PRE-SAFE® Brake may neither give warnings nor intervene in all critical situations. There is a risk of an accident.

Always pay careful attention to the traffic situation and be ready to brake.

In the event of snowfall or heavy rain, recognition can be impaired.

Recognition by the radar sensor system is also impaired in the event of:

- dirt on the sensors or the sensors are obscured
- interference by other radar sources
- strong radar reflections, for example, in multi-storey car parks
- a narrow vehicle travelling in front, e.g. a motorcycle
- a vehicle travelling in front on a different line

Recognition by the camera system is also impaired in the event of:

- dirt on the camera or if the camera is covered
- there is glare on the camera system, e.g. from the sun being low in the sky
- darkness
- if:
 - pedestrians move quickly, e.g. into the path of the vehicle
 - the camera system no longer recognises a pedestrian as a person due to special clothing or other objects
 - a pedestrian is concealed by other objects
 - the typical outline of a person is not distinguishable from the background

Following damage to the front end of the vehicle, have the radar sensor settings and operation checked at a qualified specialist workshop. This also applies to collisions at slow speeds where there is no visible damage to the front of the vehicle.

Following damage to the windscreen, have the configuration and operation of the cam-

era system checked at a qualified specialist workshop.

Function

► **To activate/deactivate:** activate or deactivate PRE-SAFE® Brake in the on-board computer (► page 278).

If the PRE-SAFE® Brake is not activated, the  symbol appears in the multifunction display.

This function will issue a warning if:

- at a speed of around 30 km/h or more the distance maintained to the vehicle travelling in front is insufficient for several seconds.

The  distance warning lamp then lights up in the instrument cluster.

- at a speed of approximately 7 km/h or higher, you very quickly approach a vehicle in front or a pedestrian.

An intermittent warning tone will then sound and the  distance warning lamp will light up in the instrument cluster.

► Brake immediately to defuse the situation.
or

► Take evasive action provided it is safe to do so.

The PRE-SAFE® Brake function can also brake the vehicle automatically under the following conditions:

- the driver and front-passenger have their seat belts fastened and
- the vehicle speed is between approximately 7 km/h and 200 km/h

At a speed of up to approximately 70 km/h, PRE-SAFE® Brake can also detect:

- stationary objects in the path of your vehicle, e.g. stopped or parked vehicles
- pedestrians in the path of your vehicle

- i** If there is an increased risk of collision, preventive passenger protection measures (PRE-SAFE®) are activated.

If the risk of collision with the vehicle in front remains and you do not brake, take evasive action or accelerate significantly, the vehicle may perform automatic emergency braking, up to the point of full brake application. Automatic emergency braking is not performed until immediately prior to an imminent accident.

You can prevent the intervention of the PRE-SAFE® Brake at any time by:

- depressing the accelerator pedal further
- activating kickdown
- releasing the brake pedal

The braking action of PRE-SAFE® Brake is ended automatically if:

- you manoeuvre to avoid the obstacle
- there is no longer a risk of collision
- there is no longer an obstacle detected in front of your vehicle

STEER CONTROL

General notes

STEER CONTROL helps you by transmitting a noticeable steering force to the steering wheel in the direction required for vehicle stabilisation.

This steering support is provided in particular if:

- both right wheels or both left wheels are on a slippery road surface when you brake heavily.
- the vehicle starts to skid.

Important safety notes

- i** Observe the "Important safety notes" section (> page 72).

If there is an ESP® malfunction, you will not receive any steering support from STEER

CONTROL. Power steering will, however, continue to function.

Anti-theft systems

Immobiliser

The immobiliser prevents your vehicle from being started without the correct key.

- ▶ **To activate with the key:** remove the key from the ignition lock.
- ▶ **To activate with KEYLESS-GO:** switch the ignition off and open the driver's door.
- ▶ **To deactivate:** switch on the ignition.

When leaving the vehicle, always take the key with you and lock the vehicle. Anyone can start the engine if a valid key has been left inside the vehicle.

- i** The immobiliser is always deactivated when you start the engine.

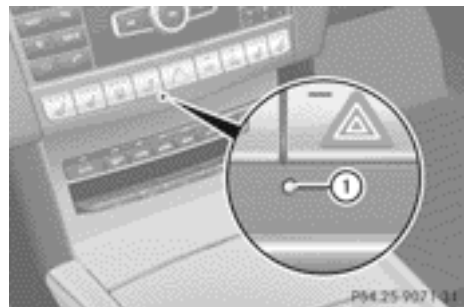

ATA (Anti-Theft Alarm system)



- ▶ **To prime:** lock the vehicle with the key or KEYLESS-GO. Indicator lamp ① flashes. The alarm system is primed after approximately 15 seconds.
- ▶ **To switch off:** unlock the vehicle with the key or KEYLESS-GO.

A visual and audible alarm is triggered if the alarm system is primed and you open:

- a door
- the vehicle with the emergency key element
- the boot lid/tailgate
- the bonnet

► **To turn the alarm off with the key:** press the  or  button on the key. The alarm is switched off.

or

► Insert the key into the ignition lock. The alarm is switched off.

► **To stop the alarm using KEYLESS-GO:** grasp the outside door handle. The key must be outside the vehicle. The alarm is switched off.

or

► Press the Start/Stop button on the dashboard. The key must be inside the vehicle. The alarm is switched off.

The alarm is not switched off, even if you close the open door that has triggered it, for example.

i If the alarm stays on for more than 30 seconds, the Mercedes-Benz emergency call system automatically sends a message to the Customer Assistance Centre. This is done by means of a text message or a data connection. The emergency call system sends a message or establishes a data connection provided that:

- you have subscribed to the Mercedes-Benz emergency call system
- the Mercedes-Benz emergency call system has been activated properly
- the necessary mobile phone network is available

Tow-away protection

Function

An audible and visual alarm is triggered if your vehicle's angle of inclination is altered while tow-away protection is primed. This can occur if the vehicle is jacked up on one side, for example.

Priming

- Make sure that:
 - the doors are closed
 - the boot lid/tailgate is closed
 Only then is the tow-away protection primed.
- Lock the vehicle with the key or KEYLESS-GO. Tow-away protection is primed after approximately 30 seconds.

Deactivating

- **To switch off:** unlock the vehicle with the key or KEYLESS-GO. Tow-away protection is switched off automatically.

Deactivating

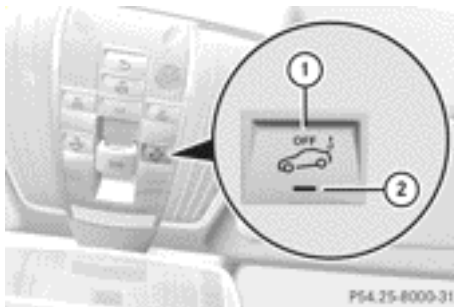

- Remove the key from the ignition lock.
- Press button **1**. Indicator lamp **2** lights up briefly.
- Lock the vehicle with the key or KEYLESS-GO. Tow-away protection is deactivated.

Tow-away protection remains deactivated until:

- the vehicle is unlocked again and
- a door is opened and closed again and
- the vehicle is locked again

To prevent a false alarm, deactivate the tow-away protection if you lock your vehicle and it:

- is being transported
- is being loaded onto a ferry or car transporter, for example
- is parked on a movable surface, e.g. in a split-level garage

Interior motion sensor

Function

When the interior motion sensor is primed, a visual and audible alarm is triggered if movement is detected in the vehicle interior. This can occur if someone reaches into the vehicle interior, for example.

Priming

- ▶ Make sure that:
 - the side windows are closed.
 - the sliding sunroof/panorama sliding sunroof is closed.
 - there are no objects, e.g. mascots, hanging on the rear-view mirror or on the grab handles on the roof trim.
 This will prevent false alarms.
- ▶ Make sure that:
 - the doors are closed.
 - the sliding sunroof/panorama sliding sunroof is closed.
 - the boot lid/tailgate is closed.
 Only then is the interior motion sensor primed.
- ▶ Lock the vehicle with the key or KEYLESS-GO.

The interior motion sensor is primed after approximately 30 seconds.

Deactivating

- ▶ Unlock the vehicle with the key or KEYLESS-GO.

The interior motion sensor is automatically deactivated.

Deactivating

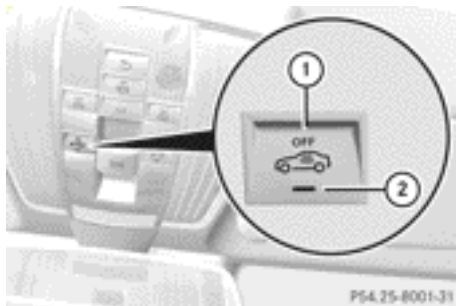

- ▶ Remove the key from the ignition lock.
- ▶ Press button ①.

Indicator lamp ② flashes briefly.
- ▶ Lock the vehicle with the key or KEYLESS-GO.

The interior motion sensor is deactivated.

The interior motion sensor remains deactivated until:

- the vehicle is unlocked again and
- a door is opened and closed again and
- the vehicle is locked again

To prevent a false alarm, deactivate the interior motion sensor if you lock your vehicle and:

- people or animals remain in the vehicle
- the side windows remain open
- the sliding sunroof/panorama sliding sunroof remains open

- i UK only:** your vehicle is equipped with a double lock function. The doors cannot be opened from the inside if the vehicle has been locked with the key or with KEYLESS-GO (▶ page 95). Deactivate the interior motion sensor before you lock the vehicle. The doors can then be opened from the

inside after the vehicle has been locked from the outside. Observe the "Important safety notes" (▷ page 94).

Useful information	88
Key	88
Doors	94
Boot/luggage compartment	97
Side windows	104
Sliding sunroof	107

Useful information

- i** This Owner's Manual describes all models, series and optional equipment for your vehicle that were available at the time of going to press. National variations are possible. Note that your vehicle may not be equipped with all of the functions described. This is also the case for systems and functions relevant to safety.
- i** Read the information on qualified specialist workshops: (▷ page 26).

Key

Important safety notes

United Kingdom only:

WARNING

When the double locks are activated, the doors can no longer be opened from the inside. People in the vehicle can no longer get out, e.g. in hazardous situations. There is a risk of injury.

Therefore, do not leave any people unsupervised in the vehicle, particularly children, elderly people or people in need of special assistance. Do not activate the double lock when people are in the vehicle.

If the vehicle has been locked from the outside, the double lock function is activated as standard. It is then not possible to open the doors from inside the vehicle. You can deactivate the double-lock function by deactivating the interior motion sensor (▷ page 85). The doors can then be opened from the inside after the vehicle has been locked from the outside. The anti-theft alarm system is triggered if the door is opened from the inside. Switch off the alarm (▷ page 83).

All countries:

WARNING

If children are left unsupervised in the vehicle, they could:

- open the doors, thus endangering other people or road users.
- get out and disrupt traffic.
- operate the vehicle's equipment.

Additionally, children could set the vehicle in motion if, for example, they:

- release the parking brake.
- shift the automatic transmission out of parking position P.
- shift the manual transmission into neutral.
- start the engine.

There is a risk of an accident and injury.

When leaving the vehicle, always take the key with you and lock the vehicle. Never leave children or animals unattended in the vehicle. Always keep the key out of reach of children.

WARNING

If persons (particularly children) are exposed to heat or cold for a prolonged period, there is a risk of serious or even fatal injuries. Never leave persons (particularly children) unattended in the vehicle.

WARNING

If you attach heavy or large objects to the key, the key could be unintentionally turned in the ignition lock. This could cause the engine to be switched off. There is a risk of an accident.

Do not attach any heavy or large objects to the key. Remove any bulky keyrings before inserting the key into the ignition lock.

- !** Keep the key away from strong magnetic fields. Otherwise, the remote control function could be affected.

Strong magnetic fields can occur in the vicinity of powerful electrical installations.

Do not keep the key:

- with electronic devices, e.g. a mobile phone or another key
- with metallic objects, e.g. coins or metal film
- inside metallic objects, e.g. a metal case
This can affect the key's functionality.

Key functions

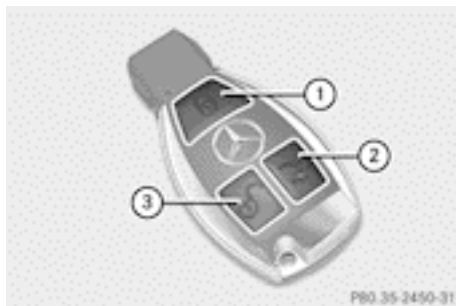

- ① To lock the vehicle
- ② To unlock the boot lid/tailgate
- ③ To unlock the vehicle

► **To unlock centrally:** press the button.

If you do not open the vehicle within approximately 40 seconds of unlocking:

- the vehicle is locked again.
- the anti-theft system is primed again.

► **To lock centrally:** press the button.

The key centrally locks/unlocks:

- the doors
- the boot lid/tailgate
- the fuel filler flap

When unlocking, the turn signals flash once. When locking, they flash three times.

You can also set an audible signal to confirm that the vehicle has been locked. The audible signal can be activated and deactivated using the on-board computer (► page 284).

When it is dark, the surround lighting also comes on if it is activated in the on-board computer (► page 283).

KEYLESS-GO

General notes

Bear in mind that the engine can be started by any of the vehicle occupants if there is a KEYLESS-GO key in the vehicle.

Locking and unlocking centrally

You can start, lock or unlock the vehicle using KEYLESS-GO. To do this, you only need carry the key with you. You can combine the KEYLESS-GO functions with the functions of a conventional key. Unlock the vehicle by using KEYLESS-GO, for instance, and lock it using the button on the key.

When locking or unlocking with KEYLESS-GO, the distance between the key and the corresponding door handle must not be greater than 1 m.

A check which periodically establishes a radio connection between the vehicle and the key determines whether a valid key is in the vehicle. This occurs, for example:

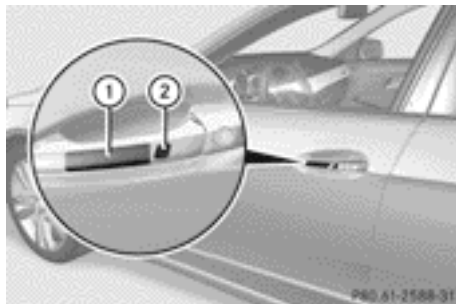

- when the external door handles are touched
- when starting the engine
- while the vehicle is in motion





- ▶ **To unlock the vehicle:** touch the inner surface of the door handle.
- ▶ **To lock the vehicle:** touch sensor surface ①.
- ▶ **Convenience closing feature:** touch recessed sensor surface ② for an extended period.
For further information on the convenience closing feature (> page 105).
- ▶ **To unlock the boot lid/tailgate:** pull the handle on the boot lid/tailgate.
The vehicle only unlocks the boot lid/tailgate.

Changing the settings of the locking system



You can change the settings of the locking system. This means that only the driver's door and the fuel filler flap are unlocked when the vehicle is unlocked. This is useful if you frequently travel on your own.

- ▶ **To change the setting:** simultaneously press the  and  buttons on the key for approximately six seconds until the battery check lamp flashes twice (> page 91).



i If the setting of the locking system is changed within the signal range of the vehicle, pressing the  or  button:

- locks or
- unlocks the vehicle

The key now functions as follows:

- ▶ **To unlock the driver's door:** press the  button once.
- ▶ **To unlock centrally:** press the  button twice.
- ▶ **To lock centrally:** press the  button.

The KEYLESS-GO function is changed as follows:

- ▶ **To unlock the driver's door:** touch the inner surface of the door handle on the driver's door.
- ▶ **To unlock centrally:** touch the inner surface of the door handle on the front-passenger door or the rear door.
- ▶ **To lock centrally:** touch the outer sensor surface on one of the door handles.
- ▶ **To restore the factory settings:** press and hold down the  and  buttons simultaneously for approximately six seconds until the battery check lamp flashes twice (> page 91).



Emergency key element

General notes

If the vehicle can no longer be locked or unlocked with the key, use the emergency key element.

If you use the emergency key element to unlock and open the driver's door or the boot lid/tailgate, the anti-theft alarm system will be triggered (> page 83).

There are several ways to turn off the alarm:

- ▶ **To turn the alarm off with the key:** press the  or  button on the key.
or
- ▶ Insert the key into the ignition lock.
or
- ▶ **To deactivate the alarm with KEYLESS-GO:** press the Start/Stop button in the ignition lock. The key must be in the vehicle.
or
- ▶ Lock or unlock the vehicle using KEYLESS-GO. The key must be outside the vehicle.

If you unlock the vehicle using the emergency key element, the fuel filler flap will not be unlocked automatically.

- ▶ **To unlock the fuel filler flap:** insert the key into the ignition lock.

Removing the emergency key element

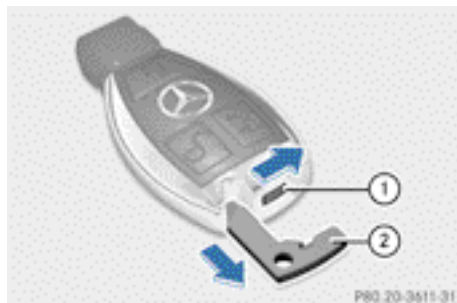

- ① Release catch
- ② Emergency key element

- ▶ Push release catch ① in the direction of the arrow and at the same time, remove emergency key element ② from the key.

For further information about:

- unlocking the driver's door (▷ page 96)
- unlocking the boot (▷ page 103)
- unlocking the tailgate (▷ page 103)
- locking the vehicle (▷ page 97)

Battery of the key

Important safety notes

⚠ WARNING

Batteries contain toxic and corrosive substances. If batteries are swallowed, it can result in severe health problems. There is a risk of fatal injury.

Keep batteries out of the reach of children. If a battery is swallowed, seek medical attention immediately.

♻ Environmental note



Batteries contain pollutants. It is illegal to dispose of them with the household rubbish. They must be collected separately and disposed of in an environmentally responsible recycling system.







Dispose of batteries in an environmentally responsible manner. Take discharged batteries to a qualified specialist workshop or to a collection point for used batteries.

Mercedes-Benz recommends that you have the batteries replaced at a qualified specialist workshop.

Checking the battery



- ▶ Press the  or  button.
The battery is working properly if battery check lamp ① lights up briefly.
The battery is discharged if battery check lamp ① does not light up briefly.
- ▶ Change the battery (▷ page 92).
- ⓘ If the key battery is checked within the signal reception range of the vehicle, pressing the  or  button:
 - locks or
 - unlocks the vehicle
- ⓘ You can get a battery at any qualified specialist workshop.

Replacing the battery

You require a CR 2025 3 V cell battery.

- ▶ Take the emergency key element out of the key (▷ page 90).

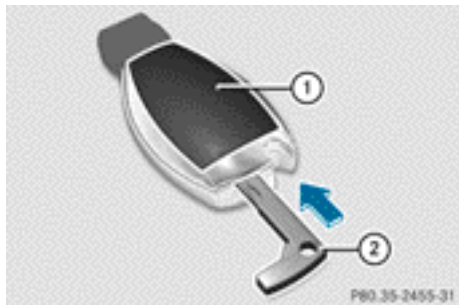

- ① Battery compartment cover
- ② Emergency key element

- ▶ Press emergency key element ② into the opening in the key in the direction of the arrow until battery compartment cover ① opens. When doing so, do not hold battery compartment cover ① shut.
- ▶ Remove battery compartment cover ①.



- ③ Battery

- ▶ Repeatedly tap the key against your palm until battery ③ falls out.
- ▶ Insert the new battery with the positive terminal facing upwards. Use a lint-free cloth to do so.

- ▶ Make sure that the surface of the battery is free of lint, grease and other contamination.
- ▶ Insert the front tabs of battery compartment cover ① into the housing and then press to close it.
- ▶ Insert emergency key element ② into the key (▷ page 90).
- ▶ Check the function of all key buttons on the vehicle.

Problems with the key	
Problem	Possible causes/consequences and ► Solutions
You can no longer lock or unlock the vehicle using the key.	<p>The key battery is discharged or nearly discharged.</p> <ul style="list-style-type: none"> ► Check the key battery (▷ page 91) and replace it if necessary (▷ page 92). <p>If this does not work:</p> <ul style="list-style-type: none"> ► Lock (▷ page 96) or unlock (▷ page 97) the vehicle using the emergency key element.
	<p>The key is faulty.</p> <ul style="list-style-type: none"> ► Lock (▷ page 96) or unlock (▷ page 97) the vehicle using the emergency key element. ► Have the key checked at a qualified specialist workshop.
You can no longer lock or unlock the vehicle using KEYLESS-GO.	<p>The key battery is discharged or nearly discharged.</p> <ul style="list-style-type: none"> ► Check the key battery (▷ page 91) and replace it if necessary (▷ page 92). <p>If this does not work:</p> <ul style="list-style-type: none"> ► Lock (▷ page 96) or unlock (▷ page 97) the vehicle using the emergency key element.
	<p>There is interference from a powerful source of radio waves.</p> <ul style="list-style-type: none"> ► Lock (▷ page 96) or unlock (▷ page 97) the vehicle using the emergency key element.
	<p>There is a fault with KEYLESS-GO.</p> <ul style="list-style-type: none"> ► Lock/unlock the vehicle using the remote control function of the key. ► Have the vehicle and key checked at a qualified specialist workshop. <p>If the vehicle can also not be locked/unlocked using the remote control function:</p> <ul style="list-style-type: none"> ► Lock (▷ page 96) or unlock (▷ page 97) the vehicle using the emergency key element. ► Have the vehicle and key checked at a qualified specialist workshop.
You have lost a key.	<ul style="list-style-type: none"> ► Have the key deactivated at a qualified specialist workshop. ► Report the loss immediately to the vehicle insurers. ► If necessary, have the locks changed as well.
You have lost the emergency key element.	<ul style="list-style-type: none"> ► Report the loss immediately to the vehicle insurers. ► If necessary, have the locks changed as well.

Problem	Possible causes/consequences and ► Solutions
The engine cannot be started using the key.	<p>the on-board voltage is too low.</p> <ul style="list-style-type: none"> ► Switch off non-essential consumers, e.g. seat heating or interior lighting, and try to start the engine again. <p>If this does not work:</p> <ul style="list-style-type: none"> ► Check the starter battery and charge it if necessary (▷ page 391). <p>or</p> <ul style="list-style-type: none"> ► Jump-start the vehicle (▷ page 393). <p>or</p> <ul style="list-style-type: none"> ► Consult a qualified specialist workshop.
Only for vehicles with manual transmission: The engine cannot be started using the key.	<p>The steering lock is mechanically blocked.</p> <ul style="list-style-type: none"> ► Remove the key and reinsert it into the ignition lock. While doing this, turn the steering wheel in both directions.
The engine cannot be started using KEYLESS-GO. The key is in the vehicle.	<p>The vehicle is locked.</p> <ul style="list-style-type: none"> ► Unlock the vehicle and try to start the vehicle again.
	<p>There is interference from a powerful source of radio waves.</p> <ul style="list-style-type: none"> ► Start your vehicle with the key in the ignition lock.

Doors

Important safety notes

United Kingdom only:

WARNING

When the double locks are activated, the doors can no longer be opened from the inside. People in the vehicle can no longer get out, e.g. in hazardous situations. There is a risk of injury.

Therefore, do not leave any people unsupervised in the vehicle, particularly children, elderly people or people in need of special assistance. Do not activate the double lock when people are in the vehicle.

If the vehicle has been locked from the outside, the double lock function is activated as standard. It is then not possible to open the doors from inside the vehicle. You can deac-

tivate the double-lock function by deactivating the interior motion sensor (▷ page 85). The doors can then be opened from the inside after the vehicle has been locked from the outside. The anti-theft alarm system is triggered if the door is opened from the inside. Switch off the alarm (▷ page 83).

All countries:

WARNING

If children are left unsupervised in the vehicle, they could:

- open the doors, thus endangering other people or road users.
- get out and disrupt traffic.
- operate the vehicle's equipment.

Additionally, children could set the vehicle in motion if, for example, they:

- release the parking brake.
- shift the automatic transmission out of parking position P.
- shift the manual transmission into neutral.
- start the engine.

There is a risk of an accident and injury.

When leaving the vehicle, always take the key with you and lock the vehicle. Never leave children or animals unattended in the vehicle. Always keep the key out of reach of children.

WARNING

If persons (particularly children) are exposed to heat or cold for a prolonged period, there is a risk of serious or even fatal injuries. Never leave persons (particularly children) unattended in the vehicle.

Stow luggage or loads preferably in the boot/luggage compartment. Observe the loading guidelines (▷ page 330).

Unlocking and opening the doors from the inside

For all countries except the United Kingdom: you can open a door from inside the vehicle even if it has been locked. If the vehicle has previously been locked with the key or with KEYLESS-GO, opening a door from the inside will trigger the anti-theft alarm system. Switch off the alarm (▷ page 83).

Only for the United Kingdom: if the vehicle has been locked with the key from the outside, the double-lock function is activated as standard. It is then not possible to open the doors from inside the vehicle. You can deactivate the double-lock function by deactivating the interior motion sensor (▷ page 85). The doors can then be opened from the inside after the vehicle has been locked from the outside. The anti-theft alarm system is triggered if the door is opened from the inside. Switch off the alarm (▷ page 83).

For all countries: You can only open the rear doors from inside the vehicle if they are not secured by the child-proof locks (▷ page 71).

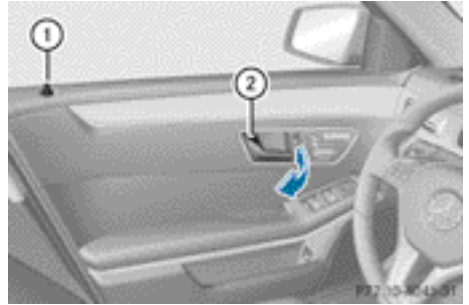

- ▶ Pull door handle (2).

If the door is locked, locking knob (1) pops up. The door is unlocked and can be opened.

Centrally locking and unlocking the vehicle from the inside

You can centrally lock or unlock the vehicle from the inside.

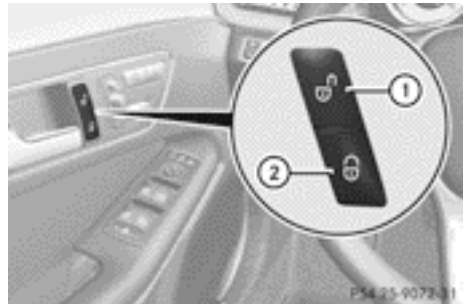

- ▶ **To unlock:** press button (1).

- ▶ **To lock:** press button (2).

If all the doors are closed, the vehicle locks.

This does not lock or unlock the fuel filler flap.

You cannot unlock the vehicle centrally from the inside if the vehicle has been locked with the key or KEYLESS-GO.

For all countries except the United Kingdom: you can open a door from inside the vehicle even if it has been locked.

United Kingdom only: you can only open a door from inside the vehicle if the double lock function has been deactivated. You can deactivate the double lock function by deactivating the interior motion sensor (▷ page 85).

All countries: You can only open the rear doors from inside the vehicle if they are not secured by the child-proof locks (▷ page 71). If the vehicle has been locked using the locking button for the central locking, or has been locked automatically, and a door is opened from the inside:

- the vehicle will be fully unlocked if it had previously been fully unlocked
- only the door which has been opened from the inside is unlocked if only the driver's door had been previously unlocked

Automatic locking feature

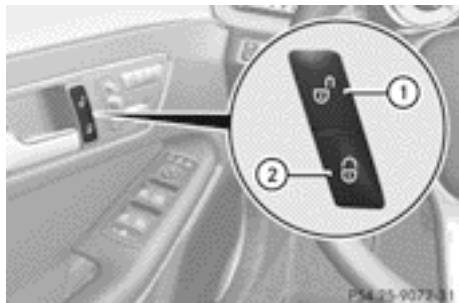

- ▶ **To deactivate:** press and hold button ① for approximately five seconds until a tone sounds.
- ▶ **To activate:** press and hold button ② for approximately five seconds until a tone sounds.

i If you press one of the two buttons and do not hear a tone, the relevant setting has already been selected.

The vehicle is locked automatically when the ignition is switched on and the wheels are turning.

You could therefore be locked out if:

- the vehicle is being pushed.
- the vehicle is being towed.
- the vehicle is being tested on a dynamometer.

You can also switch the automatic locking function on and off using the on-board computer (▷ page 284).

Unlocking the driver's door (emergency key element)

If the vehicle can no longer be unlocked with the key, use the emergency key element.

- ▶ Take the emergency key element out of the key (▷ page 90).
- ▶ Insert the emergency key element into the lock of the driver's door as far as it will go.

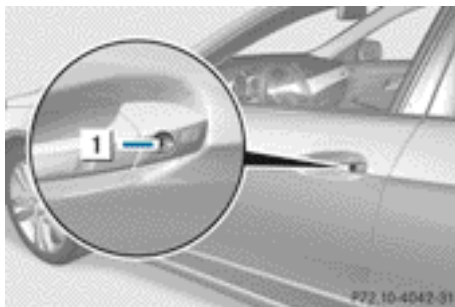

- ① To unlock
- ▶ Turn the emergency key element anti-clockwise to position ①. The door is unlocked.
- i** On right-hand-drive vehicles, turn the emergency key element clockwise.
- ▶ Turn the emergency key element back and remove it.
- ▶ Insert the emergency key element into the key.

If you use the emergency key element to unlock and open the driver's door, the anti-theft alarm system will be triggered (▷ page 83).

Locking the vehicle (emergency key element)

If the vehicle can no longer be locked with the key, use the emergency key element.

- ▶ Open the driver's door.
- ▶ Close the front-passenger door, the rear doors and the boot lid/tailgate.
- ▶ Press the locking button (▷ page 95).
- ▶ Check whether the locking knobs on the front-passenger door and the rear doors are still visible. Press down the locking knobs manually, if necessary (▷ page 95).
- ▶ Close the driver's door.
- ▶ Take the emergency key element out of the key (▷ page 90).
- ▶ Insert the emergency key element into the lock of the driver's door as far as it will go.

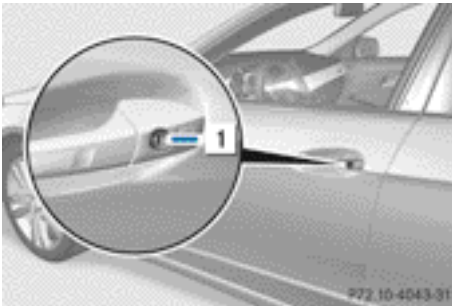

- 1** To lock
- ▶ Turn the emergency key element clockwise as far as it will go to position **1**.
 - i** On right-hand-drive vehicles, turn the emergency key element anti-clockwise.
 - ▶ Turn the emergency key element back and remove it.
 - ▶ Make sure that the doors and the boot lid/tailgate are locked.
 - ▶ Insert the emergency key element into the key.

Boot/luggage compartment

Important safety notes

⚠ WARNING

Combustion engines emit poisonous exhaust gases such as carbon monoxide. Exhaust gases can enter the vehicle interior if the boot lid/tailgate is open when the engine is running, especially if the vehicle is in motion. There is a risk of poisoning.

Always switch off the engine before opening the boot lid/tailgate. Never drive with the boot lid/tailgate open.

⚠ WARNING

If persons (particularly children) are exposed to heat or cold for a prolonged period, there is a risk of serious or even fatal injuries. Never leave persons (particularly children) unattended in the vehicle.

! The boot lid/tailgate swings upwards and to the rear when opened. Therefore, make sure that there is sufficient clearance above and behind the boot lid/tailgate.

i Opening dimensions of the boot lid/tailgate (▷ page 477).

Stow luggage or loads preferably in the boot/luggage compartment. Observe the loading guidelines (▷ page 330).

Do not leave the key in the boot/luggage compartment. You could otherwise lock yourself out.

Saloon without the boot lid remote closing feature: the boot lid can be:

- opened and closed manually from outside
- opened automatically from outside
- opened automatically from inside
- unlocked with the emergency key element

Saloon with the boot lid remote closing feature: the boot lid can be:

- opened and closed manually from outside
- opened and closed automatically from the outside

- opened and closed automatically from the inside
- unlocked with the emergency key element

Estate: you can:

- open and close the tailgate manually from outside
- open the tailgate manually from inside (Estate with a folding bench seat)
- open and close the tailgate automatically from outside
- open and close the tailgate automatically from inside
- limit the opening angle of the tailgate
- unlock the tailgate using the emergency key element

Boot lid/tailgate reversing function

The boot lid/tailgate is equipped with an automatic reversing feature. It reacts if a solid object obstructs or restricts the boot lid/tailgate during the closing procedure. The boot lid/tailgate opens again automatically. The automatic reversing function is only an aid and is not a substitute for your attentiveness to the boot lid/tailgate while it is closing.

WARNING

The reversing function does not react:

- to soft, light and thin objects, e.g. small fingers
- over the last 8 mm of the closing path

This means that the reversing feature cannot prevent someone being trapped in these situations. There is a risk of injury.

When closing make sure that no parts of the body are in the closing area.

If someone is trapped:

- press the  button on the key, or
- press the remote operating switch on the driver's door, or
- press the closing or locking button on the boot lid/tailgate, or
- pull the handle on the boot lid/tailgate

Opening/closing from the outside

Opening

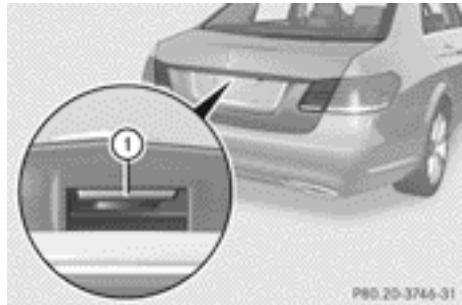

Example: Saloon, handle

- ▶ Press the  button on the key.
- ▶ **Saloon:** pull handle ①.
- ▶ Raise the boot lid.

Estate: if you pull handle ① and keep it in this position, you can open the tailgate manually. If you release the handle, the tailgate opens automatically.

Closing



Recess (example: Saloon)

- ▶ Pull the boot lid/tailgate down using recess ①.
- ▶ **Estate:** let the tailgate drop into the lock.
- ▶ If necessary, lock the vehicle with the  button on the key (▷ page 89) or with KEYLESS-GO (▷ page 89).

i If a KEYLESS-GO key is detected in the boot/luggage compartment, the boot lid/tailgate will not lock.

Saloon: the boot lid then opens again.

Opening/closing automatically from the outside

Important safety notes

United Kingdom only:

⚠ WARNING

When the double locks are activated, the doors can no longer be opened from the inside. People in the vehicle can no longer get out, e.g. in hazardous situations. There is a risk of injury.

Therefore, do not leave any people unsupervised in the vehicle, particularly children, elderly people or people in need of special assistance. Do not activate the double lock when people are in the vehicle.

If the vehicle has been locked from the outside, the double lock function is activated as standard. It is then not possible to open the doors from inside the vehicle. You can deactivate the double-lock function by deactivating the interior motion sensor (▷ page 85). The doors can then be opened from the inside after the vehicle has been locked from the outside. The anti-theft alarm system is triggered if the door is opened from the inside. Switch off the alarm (▷ page 83).

All countries:

⚠ WARNING

Parts of the body could become trapped during automatic closing of the boot lid or tailgate. Moreover, people, e.g. children, may be standing in the closing area or may enter the closing area during the closing process. There is a risk of injury.

Make sure that nobody is in the vicinity of the closing area during the closing process.

Use one of the following options to stop the closing process:

- Press the  button on the key.
- Press the remote operating switch on the driver's door.
- Press the closing or locking button on the boot lid/tailgate.
- Pull the handle on the boot lid/tailgate.

! The boot lid/tailgate swings upwards and to the rear when opened. Therefore, make sure that there is sufficient clearance above and behind the boot lid/tailgate.

i Boot lid/tailgate opening dimensions (▷ page 477).

Opening

You can open the boot lid/tailgate automatically with the key or the handle in the boot lid/tailgate.

- ▶ Press and hold the  button on the key until the boot lid/tailgate opens.
- or
- ▶ If the boot lid/tailgate is unlocked, pull the handle of the boot lid/tailgate and release it again immediately (▷ page 98).

Closing

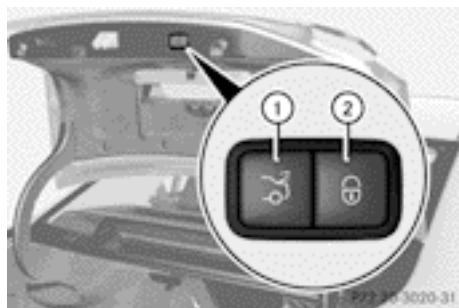

Example: Saloon, closing button and locking button

- ① Closing button
- ② Locking button

Saloon: for vehicles with the boot lid remote closing feature, you can automatically close the boot lid. For vehicles with boot lid remote closing feature and KEYLESS-GO: you can simultaneously close and lock the boot lid.

Estate: for vehicles with KEYLESS-GO, you can close and lock the tailgate simultaneously.

► **To close:** press closing button ① in the boot lid/tailgate.

► **To close and lock simultaneously:**
Press closing button ② in the boot lid/tailgate.

❗ If you leave a KEYLESS-GO key in the boot/luggage compartment, the boot lid/tailgate will not lock.

HANDS-FREE ACCESS

Important safety notes

⚠ WARNING

The vehicle exhaust system can become very hot. If you use HANDS-FREE ACCESS, you could burn yourself by touching the exhaust system. There is a risk of injury. Always ensure that you only make a leg movement within the detection range of sensors.

❗ If the key is within the rear detection range of KEYLESS-GO, the following situations, for example, could lead to the unintentional opening of the boot/tailgate:

- using a car wash
- using a high-pressure cleaner

Make sure that the key is at least 2 m away from the vehicle.

General notes

With KEYLESS-GO and HANDS-FREE ACCESS, you can open or close the boot lid/tailgate or stop the procedure without using your hands. This is useful if you have your

hands full. To do this, simply make a kicking movement under the bumper with your leg. Observe the following points:

- Carry your KEYLESS-GO key about your person. The KEYLESS-GO key must be in the rear detection range of the vehicle.
- When making the kicking movement, make sure that you are standing firmly on the ground and that there is sufficient clearance to the rear of the vehicle. You could otherwise lose your balance, e.g. on ice.

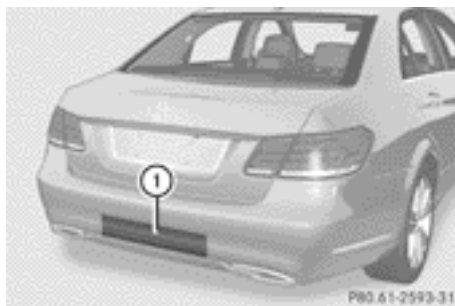

(Example: Saloon)

- Always ensure that you only make a kicking movement within the detection range of sensors ①.
 - Stand at least 30 cm away from the rear area while doing so.
 - Do not come into contact with the bumper while making the kicking movement. Otherwise, the sensors may not function correctly.
 - HANDS-FREE ACCESS does not function when the engine is started.
 - If a KEYLESS-GO key is within the rear detection range of KEYLESS-GO, HANDS-FREE ACCESS could be triggered. For this reason, the boot lid/ tailgate could open or close unintentionally, e.g. if you:
 - set something down or lift something behind the vehicle
 - polish the rear of the vehicle
- Do not carry the KEYLESS-GO key about your person in such situations. You can

thus avoid unintentionally opening or closing the boot lid/tailgate.

- Using HANDS-FREE ACCESS with a prosthetic leg may restrict functionality.

Operation

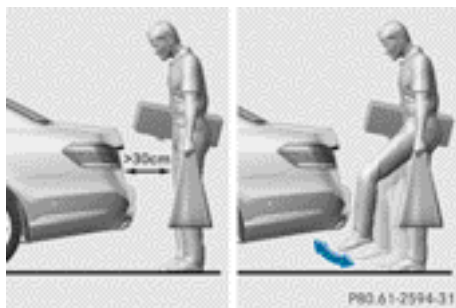

(Example: Saloon)

- ▶ **To open/close:** kick into sensor detection range ① under the bumper with your leg. You will hear a warning tone while the boot lid/tailgate is opening or closing.
 - ▶ **If the boot lid/tailgate does not open after several attempts:** wait at least ten seconds, then move your foot under the bumper again.
- i** If you hold your foot under the bumper for too long, the boot lid/ tailgate does not open or close. Repeat the leg movement more quickly if this occurs.

To stop the opening or closing procedure:

- move your foot in sensor detection range ① under the bumper
- pull the outside of the handle on the boot lid/tailgate
- press the closing button in the boot lid/ tailgate, or
- press the  button on the key

If the boot lid/tailgate closing procedure has been stopped:

- kick with your foot again under the bumper and the boot lid/tailgate will open.

If the boot lid/tailgate opening procedure has been stopped:

- move your foot again under the bumper and the boot lid/tailgate will close.

Opening/closing automatically from the inside

Important safety notes

WARNING

Parts of the body could become trapped during automatic closing of the boot lid or tailgate. Moreover, people, e.g. children, may be standing in the closing area or may enter the closing area during the closing process. There is a risk of injury.

Make sure that nobody is in the vicinity of the closing area during the closing process.

Use one of the following options to stop the closing process:

- Press the  button on the key.
- Press the remote operating switch on the driver's door.
- Press the closing or locking button on the boot lid/tailgate.
- Pull the handle on the boot lid/tailgate.

- !** The boot lid/tailgate swings upwards and to the rear when opened. Therefore, make sure that there is sufficient clearance above and behind the boot lid/tailgate.

- i** Opening dimensions of the boot lid/tailgate (▷ page 477).

Opening and closing

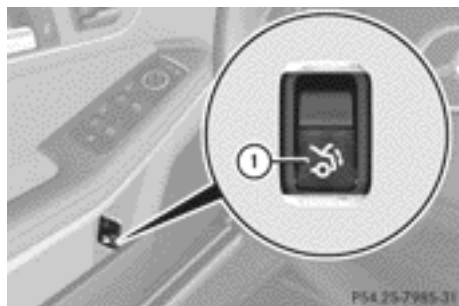

- ▶ **To open:** pull remote operating switch for boot lid/tailgate ① until the boot lid/tailgate opens.
- ▶ **To close (Saloon):** press remote operating switch for boot lid ① until the boot lid is closed.
- ▶ **To close (Estate):** turn the key to position **1** or **2** in the ignition lock.
- ▶ Press remote operating switch for tailgate ① until the tailgate is closed.

You can open and close the boot lid/tailgate from the driver's seat when the vehicle is stationary and unlocked.

You can open and close the boot lid/tailgate from the driver's seat when the vehicle is stationary and unlocked.

Limiting the opening angle of the tailgate (Estate)

Important safety notes

- !** Make sure there is sufficient clearance to open the tailgate fully when setting the opening angle. The tailgate could otherwise be damaged. Ideally, set the opening angle outside.

Priming

You can limit the opening angle of the tailgate. This is possible in the top half of its opening range, up to approximately 20 cm before the stop.

- ▶ **To open the tailgate:** pull the handle on the tailgate.
- ▶ **To stop the opening procedure at the desired position:** press the closing button (▷ page 99) in the tailgate or pull the handle on the outside of the tailgate again.
- ▶ **To store the position:** press and hold the closing button in the tailgate until you hear a short tone. The opening angle limiter is activated. The tailgate then stops in the stored position when opened.

Deactivating

- ▶ Press and hold the closing button (▷ page 99) in the tailgate until you hear two short tones.

Opening the tailgate from inside the vehicle (Estate with a folding bench seat)

General notes

- i** Tailgate opening dimensions (▷ page 477)

To open

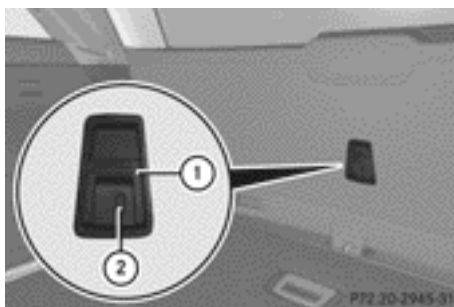

Inside of tailgate

- ▶ **To unlock the tailgate:** slide locking catch ② to the right.
- ▶ **To open:** pull the top of handle ①.
- ▶ Lift the tailgate upwards.
- ▶ **To lock the tailgate:** slide locking catch ② to the left.

Unlocking the boot (Saloon)

! The boot lid swings upwards when opened. Therefore, make sure that there is sufficient clearance above the boot lid.

If the boot cannot be unlocked with the key or KEYLESS-GO, use the emergency key element.

If you use the emergency key element to unlock and open the boot lid, the anti-theft alarm system will be triggered (▷ page 83).

- ▶ Take the emergency key element out of the key (▷ page 90).
- ▶ Insert the emergency key element into the boot lid lock as far as the stop.

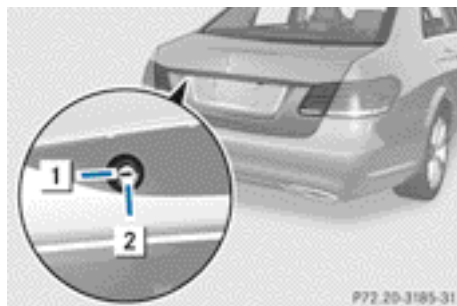

- ① Neutral position
- ② To unlock

- ▶ Turn the emergency key element anti-clockwise from position ① as far as it will go to position ②. The boot is unlocked.
- ▶ Turn the emergency key element back to position ① and remove it.
- ▶ Insert the emergency key element into the key.

i When you lock the vehicle (▷ page 97), the boot is also locked.

Tailgate emergency release (Estate)

General notes

! The tailgate swings upwards and to the rear when opened. Therefore, make sure that there is sufficient clearance above and behind the tailgate.

i Opening dimensions of the boot lid/tailgate (▷ page 477).

If the tailgate can no longer be opened from outside the vehicle, use the emergency release on the inside of the tailgate.

On vehicles with a folding bench seat, you can open the tailgate from inside the vehicle using the handle (▷ page 98).

To open

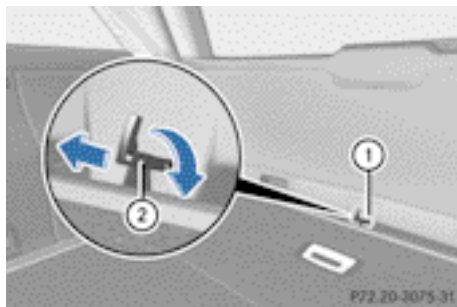

- ▶ Take the emergency key element out of the key (▷ page 90).
 - ▶ Insert emergency key element ② into the opening in trim ①.
 - ▶ Turn emergency key element ② 90° clockwise.
 - ▶ Push emergency key element ② in the direction of the arrow and open the tailgate.
- i** When you lock the vehicle (▷ page 97), the luggage compartment is also locked.

Side windows

Important safety notes

WARNING

While opening the side windows, body parts could become trapped between the side window and the door frame as the side window moves. There is a risk of injury.

Make sure that nobody touches the side window during the opening procedure. If somebody becomes trapped, release the switch or pull the switch to close the side window again.

WARNING

While opening the side windows, body parts in the closing area could become trapped. There is a risk of injury.

Make sure that no body parts are in close proximity during the closing procedure. If somebody becomes trapped, release the switch or press the switch to open the side window again.

WARNING

If children operate the side windows they could become trapped, particularly if they are left unsupervised. There is a risk of injury.

Activate the override feature for the rear side windows. When leaving the vehicle, always take the key with you and lock the vehicle. Never leave children unattended in the vehicle.

Side window reversing feature

The side windows are equipped with an automatic reversing feature. If a solid object blocks or restricts a side window during the closing process, the side window opens again automatically. The automatic reversing feature is however only an aid and is no substitute for your attention when closing a side window.

WARNING

The reversing function does not react:

- to soft, light and thin objects, e.g. small fingers
- over the last 4 mm of the closing movement
- during resetting
- when closing the side window again manually immediately after automatic reversing

This means that the reversing function cannot prevent someone being trapped in these situations. There is a risk of injury.

When closing make sure that no parts of the body are in the closing area. If someone becomes trapped, press the switch to open the side window again.

Opening and closing the side windows

The switches for all side windows are located on the driver's door. There is also a switch on each door for the corresponding side window. The switches on the driver's door take precedence.



- ① Front left
- ② Front right
- ③ Rear right
- ④ Rear left

- ▶ Turn the key to position **1** or **2** in the ignition lock.
- ▶ **To open:** press the corresponding switch.
- ▶ **To close:** pull the corresponding switch.

- i** If you press the switch beyond the point of resistance, an automatic opening/closing process is started in the corresponding direction. You can stop automatic operation by pressing again.
- i** You can continue to operate the side windows after switching off the engine or removing the key. This function remains active for five minutes or until the driver's or front-passenger door is opened.
- i** The side windows cannot be operated from the rear when the override feature for the side windows is activated (▷ page 71).

Convenience opening feature



General notes

You can ventilate the vehicle before you start driving. To do this, the key is used to carry out the following functions simultaneously:

- unlock the vehicle
- open the side windows
- open the sliding sunroof or the panorama sliding sunroof and the roller sunblinds
- switch on the seat ventilation for the driver's seat

- i** The convenience opening feature can only be operated using the key. The key must be in close proximity to the vehicle.

Convenience opening feature

- ▶ Press and hold the  button until the side windows and the sliding sunroof or the panorama sliding sunroof are in the desired position.
If the roller sunblinds of the panorama sliding sunroof are closed, the roller sunblinds are opened first.
- ▶ Press and hold the  button again until the panorama sliding sunroof is in the desired position.
- ▶ **To interrupt convenience opening:** release the  button.

Convenience closing feature

Important safety notes



WARNING

When the convenience closing feature is operating, parts of the body could become trapped in the closing area of the side window and the sliding sunroof. There is a risk of injury.

Observe the complete closing procedure when the convenience closing feature is operating. When closing make sure that no parts of the body are in the closing area.

Proceed as follows if someone is trapped:

With the key:

- ▶ Release the  button.
- ▶ Press and hold the  button until the side windows and the sliding sunroof or the panorama sliding sunroof open again.

With KEYLESS-GO:

- ▶ Release the sensor surface on the door handle.
- ▶ Pull the door handle immediately and hold it.
The side windows and the sliding sunroof or the panorama sliding sunroof open.

General notes

When you lock the vehicle, you can simultaneously:

- close the side windows
- close the sliding sunroof or the panorama sliding sunroof



On vehicles with a panorama sliding sunroof, you can then close the roller sunblinds.

Using the key

- ▶ **Vehicles without KEYLESS-GO:** point the tip of the key at the door handle on the driver's door.
- ▶ **Vehicles with KEYLESS-GO:** the key must be in close proximity to the vehicle.

- ▶ Press and hold the  button until the side windows and the sliding sunroof or the panorama sliding sunroof are fully closed.
- ▶ Make sure that all the side windows and the sliding sunroof or panorama sliding sunroof are closed.

On vehicles with a panorama sliding sunroof:

- ▶ Press and hold the  button again until the roller sunblinds of the panorama sliding sunroof close.
- ▶ **To interrupt convenience closing:** release the  button.

Using KEYLESS-GO

The KEYLESS-GO key must be outside the vehicle. All the doors must be closed.

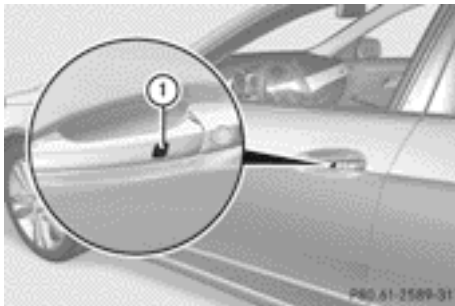

- ▶ Touch recessed sensor surface ① on the door handle until the side windows and the sliding sunroof or the panorama sliding sunroof are fully closed.
- ▶ **i** Make sure you only touch recessed sensor surface ①.
- ▶ Make sure that all the side windows and the sliding sunroof or panorama sliding sunroof are closed.

On vehicles with a panorama sliding sunroof:

- ▶ Touch recessed sensor surface ① on the door handle again until the roller sunblinds of the panorama sliding sunroof close.
- ▶ **To interrupt convenience closing:** release recessed sensor surface ① on the door handle.

Resetting the side windows

If a side window can no longer be closed fully, you must reset it.

- ▶ Close all doors.
- ▶ Turn the key to position **1** or **2** in the ignition lock.
- ▶ Pull the corresponding switch on the door control panel until the side window is completely closed. (▶ page 104)
- ▶ Hold the switch for an additional second.

If the side window opens again slightly:

- ▶ Immediately pull the corresponding switch on the door control panel until the side window is completely closed (▶ page 104).
- ▶ Hold the switch for an additional second.
- ▶ If the corresponding side window remains closed after the button has been released, the side window has been reset correctly. If this is not the case, repeat the steps above again.

Problems with the side windows

WARNING

If you close a side window again immediately after it has been blocked or reset, the side window closes with increased or maximum force. The reversing function is then not active. Parts of the body could be trapped in the closing area in the process. This poses an increased risk of injury or even fatal injury.

Make sure that no parts of the body are in the closing area. To stop the closing process, release the switch or push the switch again to reopen the side window.

Problem	Possible causes/consequences and ► Solutions
A side window cannot be closed because it is blocked by objects, e.g. leaves in the window guide.	<ul style="list-style-type: none"> ► Remove the objects. ► Close the side window.
A side window cannot be closed and you cannot see the cause.	<p>If a side window is obstructed during closing and reopens again slightly:</p> <ul style="list-style-type: none"> ► Immediately after the window blocks, pull the corresponding switch again until the side window has closed. The side window is closed with increased force. <p>If a side window is obstructed again during closing and reopens again slightly:</p> <ul style="list-style-type: none"> ► Immediately after the window blocks, pull the corresponding switch again until the side window has closed. The side window is closed without the anti-entrapment feature.

Sliding sunroof

Important safety notes

Your vehicle may be fitted with a sliding sunroof or a panorama sliding sunroof. In this section, the term "sliding sunroof" refers to both types of sliding sunroof.

WARNING

While opening and closing the sliding sunroof, body parts in close proximity could become trapped. There is a risk of injury.

Make sure that no body parts are in close proximity during the opening and closing procedures.

If somebody becomes trapped:

- release the switch immediately, or
- during automatic operation, push the switch briefly in any direction

The opening or closing procedure will be stopped.

WARNING

If children operate the sliding sunroof they could become trapped, particularly if they are left unsupervised. There is a risk of injury.

When leaving the vehicle, always take the key with you and lock the vehicle. Never leave children unattended in the vehicle.

! Only open the panorama sliding sunroof if it is free of snow and ice. Otherwise, malfunctions may occur.

Do not allow anything to protrude from the sliding sunroof. Otherwise, the seals could be damaged.

i Resonance noises can occur in addition to the usual airflow noises when the sliding sunroof is open. They are caused by minor pressure fluctuations in the vehicle interior. Change the position of the sliding sunroof or open a side window slightly to reduce or eliminate these noises.

Sliding sunroof reversing feature

The sliding sunroof is equipped with an automatic reversing feature. If an object blocks or restricts the sliding sunroof during the closing process, the sliding sunroof opens again automatically. The automatic reversing feature is however only an aid and is no substitute for your attention when closing the sliding roof.

⚠ WARNING

The reversing function does not react:

- to soft, light and thin objects, e.g. small fingers
- over the last 4 mm of the closing movement
- during resetting
- when closing the sliding sunroof again manually immediately after automatic reversing

This means that the reversing function cannot prevent someone being trapped in these situations. There is a risk of injury.

When closing make sure that no parts of the body are in the closing area.

If someone is trapped:

- release the switch immediately or
- press the switch in any direction during the automatic closing process

The closing process is stopped.

Operating the sliding sunroof

Opening and closing

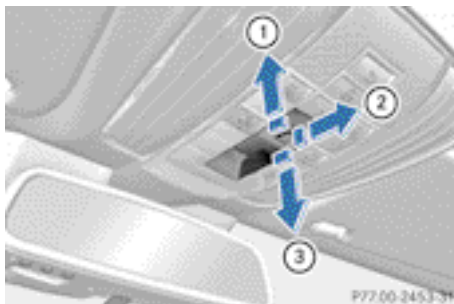

Overhead control panel

- ① To raise
- ② To open
- ③ To close/lower

► Turn the key to position **1** or **2** in the ignition lock.

► Press or pull the  switch in the corresponding direction.

i If you press the  switch beyond the point of resistance, an automatic opening/closing process is started in the corresponding direction. You can stop automatic operation by pressing again.

The sun protection cover automatically opens along with the sliding sunroof. You can open or close the sun protection cover manually when the sliding sunroof is raised or closed.

i You can continue to operate the sliding sunroof after switching off the engine or removing the key. This function remains active for five minutes or until you open a front door.

Rain-closing feature

When the key is in position **0** in the ignition lock or is removed, the sliding sunroof closes automatically:

- if it starts to rain
- at extreme outside temperatures

- after six hours
- if there is a malfunction in the power supply

The rear of the sliding sunroof is then raised in order to ventilate the vehicle interior.

- i** If the sliding sunroof is obstructed when being closed by the rain-closing feature, it opens again slightly. The rain-closing feature is then deactivated.

The sliding sunroof does not close if:

- it is raised at the rear
- it is blocked
- no rain is falling on the area of the wind-screen being monitored by the rain sensor. If the vehicle, for example, is under a bridge or in a carport, the field of the sensor may be covered.

Resetting

- !** If the sliding sunroof still cannot be opened or closed fully after resetting, contact a qualified specialist workshop.

Reset the sliding sunroof if it does not move smoothly.

- ▶ Turn the key to position **1** or **2** in the ignition lock.
- ▶ Raise the sliding sunroof fully at the rear (▷ page 108).
- ▶ Keep the  switch pressed for another second.
- ▶ Make sure that the sliding sunroof can be fully opened and closed again (▷ page 108).
- ▶ If this is not the case, repeat the steps above again.

Operating the panorama sliding sunroof

Opening and closing

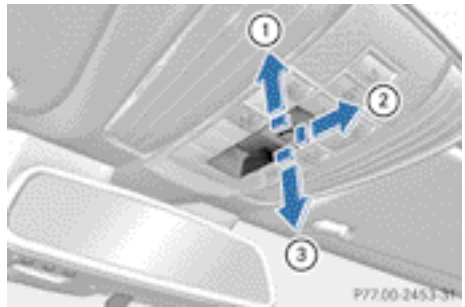

Overhead control panel

- ① To raise
- ② To open
- ③ To close/lower

- ▶ Turn the key to position **1** or **2** in the ignition lock.
- ▶ Press or pull the  switch in the corresponding direction.

- i** If you press the  switch beyond the point of resistance, an automatic opening/closing process is started in the corresponding direction. You can stop automatic operation by pressing again.

Rain-closing feature

If the key is in position **0** in the ignition lock or if it is removed, the panorama sliding sunroof closes automatically:

- if it starts to rain
- at extreme outside temperatures
- after six hours
- if there is a malfunction in the voltage supply.

The panorama sliding sunroof remains raised at the rear in order to allow ventilation of the vehicle interior.

- i** If the panorama sliding sunroof is obstructed when being closed by the rain-closing

feature, it opens again slightly. The rain-closing feature is then deactivated.

The panorama sliding sunroof does not close if:

- it is raised at the rear.
- it is blocked.
- no rain is falling on the area of the wind-screen being monitored by the rain sensor, e.g. because the vehicle is under a bridge.

Operating the panorama sliding sunroof roller sunblinds

Important safety notes

WARNING

When opening or closing the roller sunblind parts of the body could be trapped between the roller sunblind and the frame or sliding sunroof. There is a risk of injury.

When opening or closing make sure that no parts of the body are in the sweep of the roller sunblind.

If someone is trapped:

- release the switch immediately or
- press the switch in any direction during the automatic opening/closing process

The opening/closing process is stopped.

The roller sunblinds shield the vehicle interior from sunlight. The two roller sunblinds can only be opened and closed together when the panorama sliding sunroof is closed.

Roller sunblinds reversing feature

The roller sunblind is equipped with an automatic reversing feature. If an object blocks or restricts the roller sunblind during the closing process, the roller sunblind opens again automatically. The automatic reversing feature is, however, only an aid and is no substitute for your attention when closing the roller sunblind.

WARNING

The reversing feature especially does not react to soft, light and thin objects, such as small fingers. This means that the reversing feature cannot prevent someone being trapped in these situations. There is a risk of injury.

When closing make sure that no parts of the body are in the sweep of the roller sunblind. If someone is trapped:

- release the switch immediately or
- press the switch in any direction during the automatic opening/closing process

The closing process is stopped.

Opening and closing

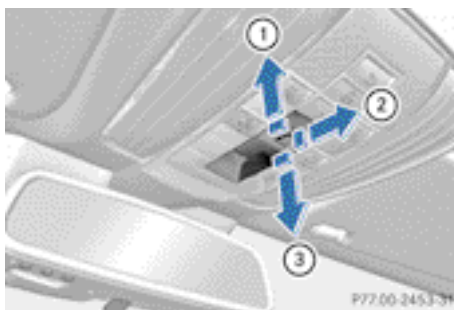

Overhead control panel

① To open

② To open

③ To close

► Turn the key to position **1** or **2** in the ignition lock.





► Press or pull the  switch in the corresponding direction.

i If you press or pull the  switch beyond the point of resistance, an automatic opening/closing process is started in the corresponding direction. You can stop automatic operation by pressing or pulling again.

Resetting the panorama sliding sunroof and the roller sunblinds

! If the panorama sliding sunroof and the roller sunblinds cannot be fully opened or closed after resetting, contact a qualified specialist workshop.

Reset the panorama sliding sunroof and the roller sunblinds if the panorama sliding sunroof or the roller sunblinds do not move smoothly.

- ▶ Turn the key to position **1** or **2** in the ignition lock.
- ▶ Pull the  switch repeatedly to the point of resistance in the direction of arrow ③ until the panorama sliding sunroof is fully closed (▷ page 110).
- ▶ Keep the  switch pulled for an additional second.
- ▶ Pull the  switch repeatedly to the point of resistance in the direction of arrow ③ until the roller sunblinds are fully closed.
- ▶ Keep the  switch pulled for an additional second.
- ▶ Make sure that the panorama sliding sunroof (▷ page 109) and the roller sunblind (▷ page 110) can be fully opened again.
- ▶ If this is not the case, repeat the steps above again.

Problems with the sliding sunroof

WARNING



If you close the sliding sunroof again immediately after it has been blocked or reset, the sliding sunroof closes with increased or maximum force. The reversing function is then not active. Parts of the body could be trapped in the closing area in the process. This poses an increased risk of injury or even fatal injury.

Make sure that no parts of the body are in the closing area.

If someone is trapped:

- release the switch immediately or
- press the switch in any direction during the automatic opening/closing process

The closing process is stopped.

Problem	Possible causes/consequences and ► Solutions
The sliding sunroof cannot be closed and you cannot see the cause.	<p>If the sliding sunroof is obstructed during closing and reopens again slightly:</p> <ul style="list-style-type: none"> ► Immediately after the sliding sunroof blocks, pull the  switch in the overhead control panel down to the point of resistance and hold it until the sliding sunroof is closed. The sliding sunroof is closed with increased force. <p>If the sliding sunroof is obstructed again during closing and reopens again slightly:</p> <ul style="list-style-type: none"> ► Immediately after the sliding sunroof blocks, pull the  switch in the overhead control panel down to the point of resistance and hold it until the sliding sunroof is closed. The sliding sunroof is closed without the anti-entrapment feature.

Useful information	114
Correct driver's seat position	114
Seats	115
Steering wheel	126
Mirrors	129
Memory function	132

Useful information

i This Owner's Manual describes all models, series and optional equipment for your vehicle that were available at the time of going to press. National variations are possible. Note that your vehicle may not be equipped with all of the functions described. This is also the case for systems and functions relevant to safety.

i Read the information on qualified specialist workshops: (▷ page 26).

Correct driver's seat position

⚠ WARNING

You could lose control of the vehicle while driving if you:

- adjust the driver's seat, steering wheel or mirrors
- fasten the seat belt

There is a risk of an accident.

Adjust the driver's seat, head restraint, steering wheel and mirrors and fasten your seat belt before starting the engine.



- ▶ Observe the safety guidelines on seat adjustment (▷ page 115).
- ▶ Make sure that seat ③ is correctly adjusted.

Manual and electrical seat adjustment (▷ page 116)

Electrical seat adjustment (▷ page 116)

When adjusting the seat, make sure that:

- you are as far away from the driver's airbag as possible.
- you are sitting in a normal upright position.
- you can fasten the seat belt properly.
- you have moved the backrest to an almost vertical position.
- you have set the seat angle so that your thighs are gently supported.
- you can depress the pedals properly.

- ▶ Check whether the head restraint is adjusted correctly.

When doing so, make sure that you have adjusted the head restraint so that the back of your head is supported at eye level by the centre of the head restraint.

- ▶ Observe the safety guidelines on steering wheel adjustment (▷ page 126).
- ▶ Make sure that steering wheel ① is adjusted correctly.

Adjusting the steering wheel manually (▷ page 126)

Adjusting the steering wheel electrically (▷ page 127)

When adjusting the steering wheel, make sure that:

- you can hold the steering wheel with your arms slightly bent.
- you can move your legs freely.
- you can see all the displays in the instrument cluster clearly.
- ▶ Observe the safety guidelines for seat belts (▷ page 51).
- ▶ Check whether you have fastened seat belt ② properly (▷ page 52).

The seat belt should:

- fit snugly across your body.
 - be routed across the middle of your shoulder.
 - be routed in your pelvic area across the hip joints.
- ▶ Before starting off, adjust the rear-view mirror and the exterior mirrors so that you have a good view of road and traffic conditions (▷ page 129).
- ▶ **Vehicles with a memory function:** save the seat, steering wheel and exterior mirror settings with the memory function (▷ page 132).

Seats

Important safety notes

WARNING

If children adjust the seats, they could become trapped, especially if they are unattended. There is a risk of injury.

When leaving the vehicle, always take the key with you and lock the vehicle. Never leave children unattended in the vehicle.

WARNING

You could lose control of the vehicle while driving if you:

- adjust the driver's seat, steering wheel or mirrors
- fasten the seat belt

There is a risk of an accident.

Adjust the driver's seat, head restraint, steering wheel and mirrors and fasten your seat belt before starting the engine.

WARNING

If you adjust the seat height carelessly, you or other vehicle occupants could be trapped and thereby injured. Children in particular could accidentally press the electrical seat adjust-

ment buttons and become trapped. There is a risk of injury.

While moving the seats, make sure that your hands or other body parts do not get under the lever assembly of the seat adjustment system.

WARNING

When adjusting a seat, you or another vehicle occupant could become trapped by the guide rail of the seat, for instance. There is a risk of injury.

Make sure that no one has any part of their body within the sweep of the seat when adjusting it.

WARNING

The head restraints cannot provide the intended protection unless they are fitted and adjusted correctly. There is an increased risk of injury to the head and neck in the event of an accident or sudden braking, for example. Always drive with the head restraints fitted. Ensure that the centre of the head restraints support the back of each vehicle occupant's head at eye level before driving off.

WARNING

The seat belt does not offer the intended level of protection if you have not moved the backrest to an almost vertical position. When braking or in the event of an accident, you could slide underneath the seat belt and sustain abdomen or neck injuries, for example. This poses an increased risk of injury or even fatal injury.

Adjust the seat properly before beginning your journey. Always ensure that the backrest is in an almost vertical position and that the shoulder section of your seatbelt is routed across the centre of your shoulder.

! To avoid damage to the seats and the seat heating, observe the following information:

- do not spill any liquids on the seats. If liquid is spilled on the seats, dry them as soon as possible.
- if the seat covers are damp or wet, do not switch on the seat heating. The seat heating should also not be used to dry the seats.
- clean the seat covers as recommended; see "Interior care".
- do not transport heavy loads on the seats. Do not place sharp objects on the seat cushions, e.g. knives, nails or tools. The seats should only be occupied by passengers, if possible.
- when the seat heating is in operation, do not cover the seats with insulating materials, e.g. blankets, coats, bags, seat covers, child seats or booster seats.

! Make sure that there are no objects in the footwell or behind the seats when moving the seat back. There is a risk that the seats and/or the objects could be damaged.

i The head restraints in the front seats are fitted with the NECK-PRO system (▷ page 49). For this reason, it is not possible to remove the head restraints from the front seats.

Vehicles without the through-loading feature: the head restraints cannot be removed from the rear compartment seats. For more information, contact a qualified specialist workshop.

i Further related subjects:

- Through-loading facility in the rear bench seat (Saloon) (▷ page 336)
- EASY-PACK through-loading facility in the rear bench seat (Estate) (▷ page 337)

Adjusting the seats manually and electrically

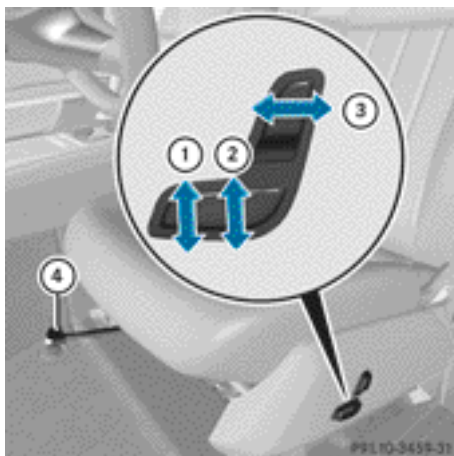

- ① Seat cushion angle
- ② Seat height
- ③ Backrest angle
- ④ Seat fore-and-aft adjustment

- ▶ **Seat fore-and-aft adjustment:** lift lever ④ and slide the seat forwards or backwards.
- ▶ Release lever ④ again. Make sure that you hear the seat engage in position.

Adjusting the seats electrically



- ① Head restraint height
- ② Seat cushion angle
- ③ Seat height

- ④ Seat fore-and-aft adjustment
- ⑤ Backrest angle
- ❗ Vehicles with memory function: if PRE-SAFE® has been triggered, the front-passenger seat will be moved to a better position if it was previously in an unfavourable position.
- ❗ You can store the seat settings using the memory function (> page 132).
- ❗ Vehicles with the through-loading feature and memory function: if you fold down a rear seat backrest, the respective front seat is moved forwards slightly if necessary.
- ❗ Vehicles with memory function: when the seat is moved forwards or backwards, the headrest is moved up or down automatically.

Adjusting the head restraints

Important safety notes

⚠ WARNING

You could lose control of the vehicle while driving if you:

- adjust the driver's seat, steering wheel or mirrors
- fasten the seat belt

There is a risk of an accident.

Adjust the driver's seat, head restraint, steering wheel and mirrors and fasten your seat belt before starting the engine.

⚠ WARNING

The head restraints cannot provide the intended protection unless they are fitted and adjusted correctly. There is an increased risk of injury to the head and neck in the event of an accident or sudden braking, for example. Always drive with the head restraints fitted. Ensure that the centre of the head restraints

support the back of each vehicle occupant's head at eye level before driving off.

General notes

Observe the important safety notes regarding the seats (> page 115).

Do not interchange the head restraints of the front and rear seats. Otherwise, you will not be able to adjust the height and angle of the head restraints to the correct position.

Adjusting the head restraints manually

Adjusting the head restraint height

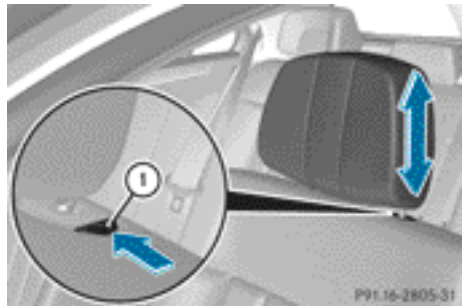

Vehicles without Rear Seat Entertainment System

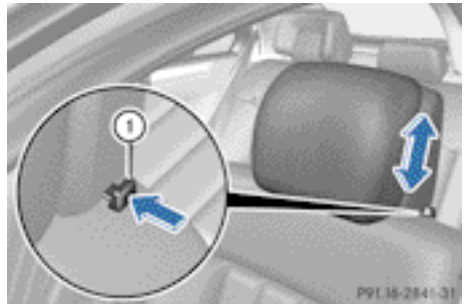

Vehicles with Rear Seat Entertainment System

- ▶ **To raise:** pull the head restraint up to the desired position.
- ▶ **To lower:** press release catch ① in the direction of the arrow and push the head restraint down to the desired position.

Adjusting the angle of the head restraints

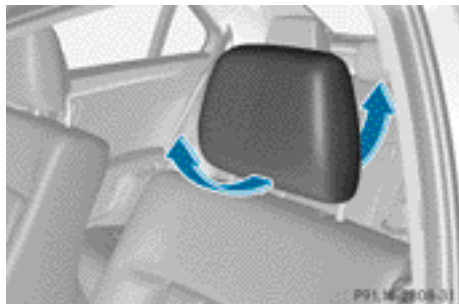

Example: Saloon

- ▶ Push or pull the lower edge of the head restraint in the direction of the arrow.

Adjusting the head restraints electrically



- ▶ **To adjust the head restraint height:** slide the switch for head restraint adjustment ① up or down in the direction of the arrow.

Adjusting the luxury head restraints

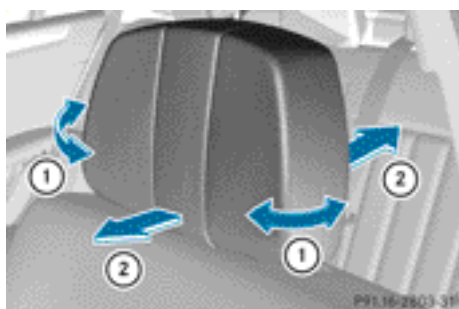

- ▶ **To adjust the side bolsters of the head restraint:** push or pull right or left-hand side bolster ① into the desired position.

- ▶ **To adjust the angle of the head restraint:** push or pull the head restraint in the direction of arrow ②.

- ① Adjust the head restraint so that the back of your head is as close to the head restraint as possible.

Rear seat head restraints

Lowering the rear seat head restraints from the front

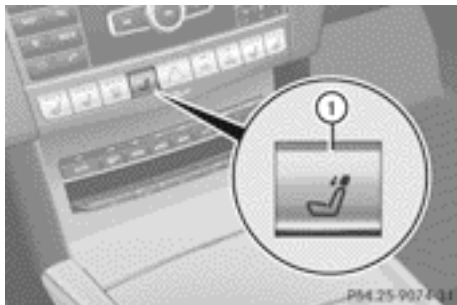

- ▶ Turn the key to position 2 in the ignition lock (▶ page 177).
- ▶ Press button ①.

Adjusting the rear seat head restraint height

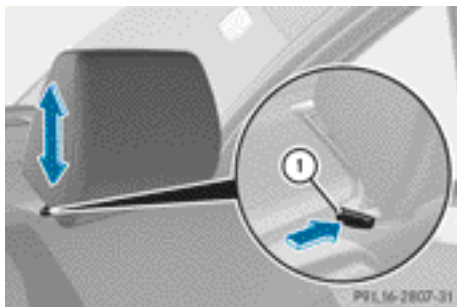

Example: Saloon

On certain vehicles, only the outer head restraints are height-adjustable.

- ▶ **To raise:** pull the head restraint up to the desired position.
- ▶ **To lower:** press release catch ① and push the head restraint down until it is in the desired position.

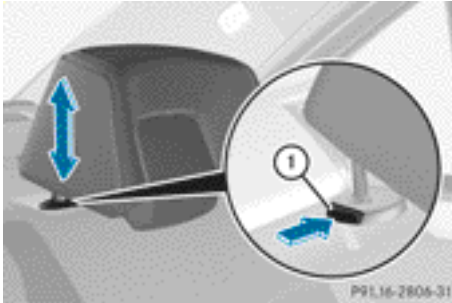

Luxury head restraints (vehicles with luxury individual rear seats)

On certain vehicles, only the outer head restraints are height-adjustable.

- ▶ **To raise:** pull the head restraint up to the desired position.
- ▶ **To lower:** press release catch ① and push the head restraint down until it is in the desired position.

i If you pull the head restraint forward slightly, less effort is required to adjust it.

Adjusting the rear seat head restraint angle

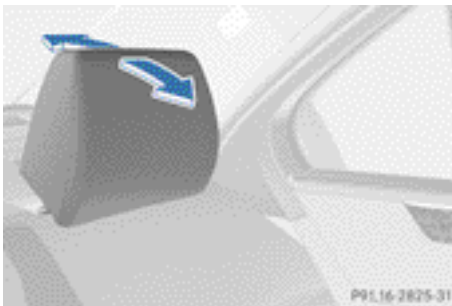

Example: Saloon

- ▶ Pull or push the top of the head restraint until it is in the desired position.

Removing and fitting the rear seat head restraints

⚠ WARNING

The head restraints cannot provide the intended protection unless they are fitted and adjusted correctly. There is an increased risk of injury to the head and neck in the event of an accident or sudden braking, for example. Always drive with the head restraints fitted. Ensure that the centre of the head restraints support the back of each vehicle occupant's head at eye level before driving off.

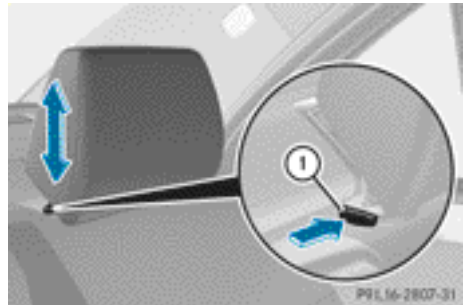

Example: Saloon

You can only remove and refit the rear head restraints on vehicles with a through-loading facility.

- ▶ Release the rear seat backrest and fold it slightly forwards (▷ page 336).
- ▶ **To remove:** pull the head restraint up to the stop.
- ▶ Press release catch ① and pull the head restraint out of the guides.
- ▶ **To refit:** insert the head restraint so that the notches on the bar appear on the left when viewed in the direction of travel.
- ▶ Push the head restraint down until it audibly engages in position.
- ▶ Fold back the rear seat backrest until it engages.

Adjusting the multicontour seat

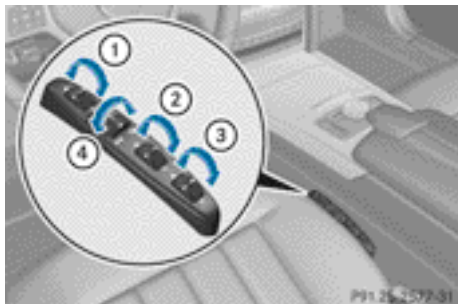

- ① To adjust the thigh cushion
- ② To adjust the backrest contour in the lumbar region
- ③ To adjust the backrest contour in the upper back region
- ④ To adjust the side bolsters of the seat backrest

You can adjust the contour of the front seats individually so as to provide optimum support for your back and sides.

- ▶ Turn the key to position **2** in the ignition lock (> page 177).

Adjusting the active multicontour seat

Overview

- i** Depending on the vehicle's equipment, operation is performed using COMAND or the control panel on the seat.

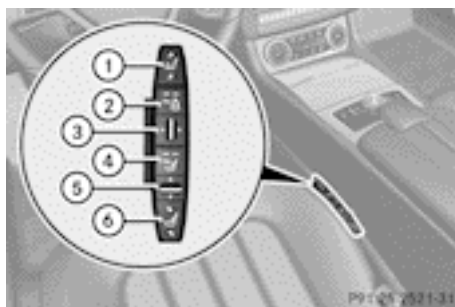

- ① To adjust the seat cushion length
- ② To switch the dynamic function on or off
- ③ To adjust the side bolsters of the seat backrest
- ④ To switch the massage function on or off
- ⑤ To adjust the contour of the backrest to increase/decrease support
- ⑥ To adjust the height/depth of the backrest contour

The active multicontour seat automatically adapts the sides of the backrest to your current driving style.

Dynamic function

The dynamic function adjusts the air cushions in the side bolsters of the seat backrests to ensure ideal lateral support at all times. You can choose between two levels.

- ▶ **To switch on:** press button ② once or twice until the desired level is set. One or two indicator lamps in button ② light up.
- ▶ **To switch off:** press button ② repeatedly until all indicator lamps in button ② go out.

You can select the following levels:

Level 1 (one indicator lamp)	Standard setting: slightly increased lateral support and slow build-up of air pressure in the side bolsters of the seat backrest.
Level 2 (two indicator lamps)	Sport setting: increased lateral support and fast build-up of pressure in the side bolsters of the seat backrest.

Message function (PULSE)

The massage function helps you to prevent muscle tension on long journeys. You can choose between two levels.

- **To switch on:** press button ④ once or twice until the desired level is set. One or two indicator lamps in button ④ light up. The air cushions in the lumbar region vibrate for approximately 20 minutes.

Adjusting with COMAND

You can adjust the active multicontour seat using COMAND. You can find further information in the separate COMAND Online operating instructions.

Adjusting the 4-way lumbar support

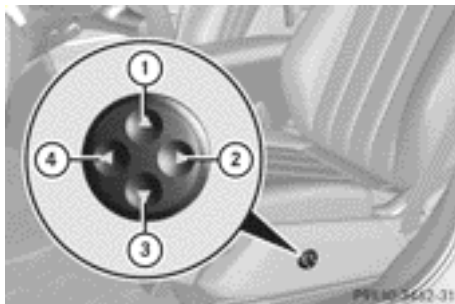

- ① To raise the backrest contour
- ② To soften the backrest contour
- ③ To lower the backrest contour
- ④ To harden the backrest contour

You can adjust the contour of the front seat backrests individually to provide optimum support for your back.

Folding bench seat in the luggage compartment (Estate)

Important safety notes

WARNING

If the backrests of the rear bench seat are not locked in the upright position, the backrest may fold down while driving. In this case, the seatbelt may not perform its intended protective function. This poses an increased risk of injury.

Make sure that the backrests of the rear bench seat are locked in the upright position.

The folding bench seat in the luggage compartment is only suitable for persons no more than 1.40 m tall and weighing a maximum of 50 kg.

Observe the loading guidelines (► page 330).

The maximum permissible weight may be reduced by:

- extensive optional extras
- vehicle load
- towing a trailer

The combined luggage cover and net must be fitted if you are using the folding bench seat (▷ page 341).

Folding out the folding bench seat

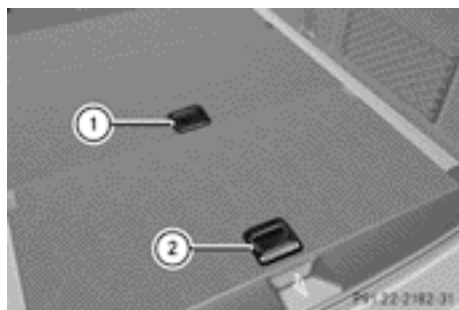

- ▶ Make sure that the backrests of the rear bench seat are locked in the upright position.
- ▶ Move the handle for the combined luggage cover and net upwards (▷ page 341).
- ▶ Pull release handle ① and fold the backrest of the folding bench seat upwards.

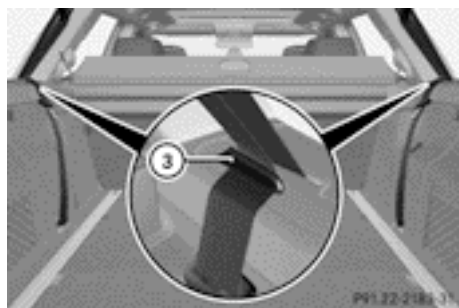

- ▶ Hook the seat belts into retainers ③.
- ▶ Pull release handle ② and fold the folding bench seat cushion into the sitting position.

- ▶ Push down the seat cushion until the backrest engages fully.
- ▶ Fold the head restraints upwards.

Fitting and removing the seat cushion

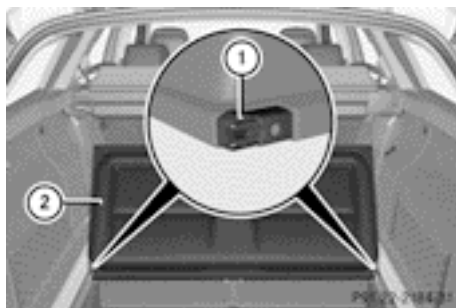

You must remove the seat cushion if you wish to lift the luggage compartment floor if the vehicle has a flat tyre, for example.

- ▶ **To remove:** fold seat cushion ② upwards and remove it from seat cushion guides ①.

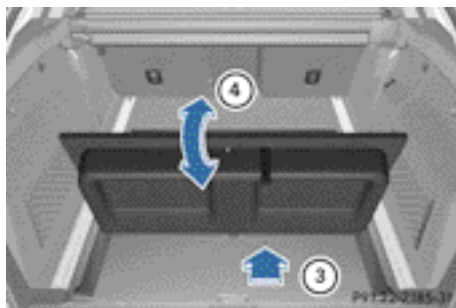

- ▶ **To fit:** push seat cushion ② into seat cushion guides ① at a slight angle from the rear ③.
- ▶ Fold seat cushion ② back into its original position ④ until it engages.

Folding back the folding bench seat

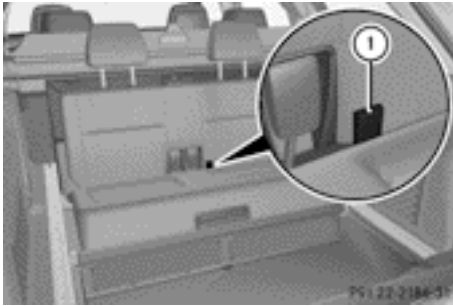

- ▶ Pull the seat cushion upwards by tab ① and fold it back into its original position until it engages.

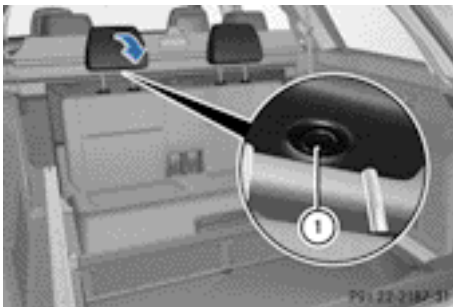

- ▶ Press release button ① and fold the head restraints down.

! In order to avoid causing damage, push the head restraints completely into their guides and click the seat belt buckles into their guides.

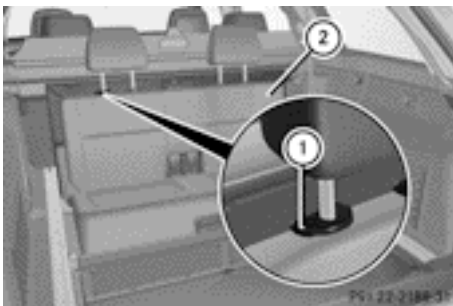

- ▶ Press release button ① and push the head restraints all the way in.
- ▶ Fold backrest ② of the folding bench seat into its original position until it engages.

Switching the seat heating on/off

Activating/deactivating

WARNING

If you repeatedly switch on seat heating, the seat cushion and backrest padding may become very hot. The health of vehicle occupants with limited temperature sensitivity or a limited ability to react to excessively high temperatures may be affected or they may even suffer burn-like injuries. There is a risk of injury.

Therefore, do not switch on the seat heating repeatedly.



Driver's and front-passenger seat

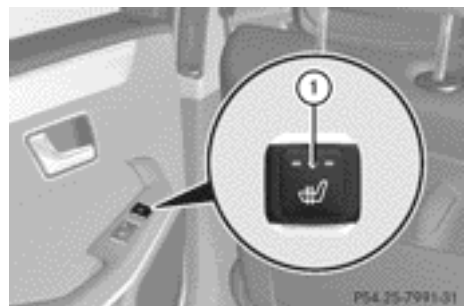

Rear seats

The three red indicator lamps in the button indicate the heating level you have selected.

Driver's and front-passenger seat: the system automatically switches from level **3** to level **2** after approximately eight minutes.

Rear seat: the system automatically switches from level **3** to level **2** after approximately five minutes.

The system automatically switches down from level **2** to level **1** after approximately ten minutes.

The system automatically switches off approximately 20 minutes after it is set to level **1**.

- ▶ Turn the key to position **1** or **2** in the ignition lock (▷ page 177).
- ▶ **To switch on:** press button ① repeatedly until the desired heating level is set.
- ▶ **To switch off:** press button ① repeatedly until all the indicator lamps go out.

i If the battery voltage is too low, the seat heating may switch off.

Problems with the seat heating

Problem	Possible causes/consequences and ► Solutions
The seat heating has switched off prematurely or cannot be switched on.	<p>The on-board voltage is too low because too many electrical consumers are switched on.</p> <p>► Switch off electrical consumers that you do not need, such as the rear window heating or interior lighting.</p> <p>Once the battery is sufficiently charged, the seat heating will switch back on automatically.</p>

Switching the seat ventilation on/off

Activating/deactivating



Driver's and front-passenger seat

The three blue indicator lamps in the buttons indicate the ventilation level you have selected.

- Turn the key to position **1** or **2** in the ignition lock (► page 177).
- **To switch on:** press button ① repeatedly until the desired ventilation level is set.
- **To switch off:** press button ① repeatedly until all the indicator lamps go out.

- i** If the battery voltage is too low, the seat ventilation may switch off.
- i** You can open the side windows and the sliding sunroof using the "Convenience opening" feature (► page 105). The seat ventilation of the driver's seat automatically switches to the highest level.

Problems with the seat ventilation

Problem	Possible causes/consequences and ► Solutions
The seat ventilation has switched off prematurely or cannot be switched on.	<p>The on-board voltage is too low because too many electrical consumers are switched on.</p> <p>► Switch off electrical consumers that you do not need, such as the rear window heating or interior lighting.</p> <p>Once the battery is sufficiently charged, the seat ventilation will switch back on automatically.</p>

Steering wheel

Important safety notes

⚠ WARNING

You could lose control of the vehicle while driving if you:

- adjust the driver's seat, steering wheel or mirrors
- fasten the seat belt

There is a risk of an accident.

Adjust the driver's seat, head restraint, steering wheel and mirrors and fasten your seat belt before starting the engine.

⚠ WARNING

Children could become trapped by the steering wheel if they adjust it. There is a risk of injury.

When leaving the vehicle, always take the key with you and lock the vehicle. Never leave children unattended in the vehicle.

Adjusting the steering wheel manually



- ① Release lever
 - ② To adjust the steering wheel height
 - ③ To adjust the steering wheel position (fore-and-aft adjustment)
- Push release lever ① down completely. The steering column is unlocked.
 - Adjust the steering wheel to the desired position.
 - Push release lever ① up completely. The steering column is locked.
 - Check if the steering column is locked. When doing so, try to push the steering wheel up or down or try to move it in the fore-and-aft direction.

Adjusting the steering wheel electrically

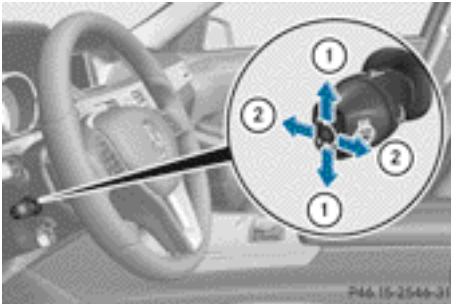

- ① To adjust the steering wheel height
- ② To adjust the steering wheel position (fore-and-aft adjustment)

i Further related subjects:

- EASY-ENTRY/EXIT feature (▷ page 128)
- Storing settings (▷ page 132)

Steering wheel heating

Activating/deactivating

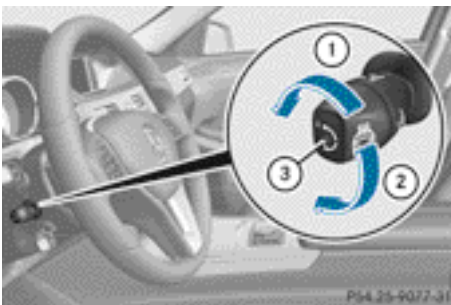

- ▶ Turn the key to position **2** in the ignition lock (▷ page 177).
- ▶ **To switch on/off:** turn the lever in the direction of arrow ① or ②. Indicator lamp ③ lights up or goes out.

Vehicles without KEYLESS-GO: when you remove the key from the ignition lock, the steering wheel heating is switched off.

Vehicles with KEYLESS-GO: when you switch off the ignition and open the driver's door, the steering wheel heating is switched off.

- i** The steering wheel heating does not switch off automatically.

Problems with the steering wheel heating

Problem	Possible causes/consequences and ► Solutions
The steering wheel heating has switched itself off prematurely or cannot be switched on.	<p>The on-board voltage is too low because too many electrical consumers are switched on.</p> <p>► Switch off electrical consumers that you do not need, such as the rear window heating or interior lighting.</p> <p>Once the battery is sufficiently charged, the steering wheel heating will switch back on automatically.</p>

EASY-ENTRY/EXIT feature

Important safety notes

WARNING

When the EASY-ENTRY/EXIT feature adjusts the steering wheel, you and other vehicle occupants – particularly children – could become trapped. There is a risk of injury.

While the EASY-ENTRY/EXIT feature is making adjustments, make sure that no one has any body parts in the sweep of the steering wheel.

If someone is trapped:

- press one of the memory function position buttons, or
- move the switch for steering wheel adjustment in the opposite direction to that in which the steering wheel is moving.

The adjustment process is stopped.

WARNING

If children activate the EASY-ENTRY/EXIT feature, they can become trapped, particularly when unattended. There is a risk of injury.

When leaving the vehicle, always take the key with you and lock the vehicle. Never leave children unattended in the vehicle.

WARNING

If you drive off while the EASY-ENTRY/EXIT feature is making adjustments, you could lose control of the vehicle. There is a risk of an accident.

Always wait until the adjustment process is complete before driving off.

The EASY-ENTRY/EXIT feature makes getting in and out of your vehicle easier.

You can activate and deactivate the EASY-ENTRY/EXIT feature in the on-board computer (► page 285).

Position of the steering wheel when the EASY-ENTRY/EXIT feature is active

The steering wheel tilts upwards if you:

- remove the key from the ignition lock
- **with KEYLESS-GO:** open the driver's door; KEYLESS-GO must be in position **1** in the ignition lock
- **with the key:** open the driver's door; the key must be in position **0** or **1** in the ignition lock (► page 177)

 The steering wheel only moves upwards if it has not already reached the upper end stop.

Position of the steering wheel for driving

The steering wheel is moved to the previously set position if:

- the driver's door is closed and
- **with KEYLESS-GO:** you press the Start/Stop button once on vehicles with KEYLESS-GO

or

- **with the key:** you insert the key into the ignition lock.

If you close the driver's door with the key inserted in the ignition lock, the steering wheel is automatically moved to the previously set position.

The last position of the steering wheel is stored when you switch off the ignition or when you store the setting with the memory function (> page 132).

Crash-responsive EASY-EXIT feature

If the crash-responsive EASY-EXIT feature is triggered in an accident, the steering column will move upwards when the driver's door is opened. This occurs irrespective of the position of the key in the ignition lock. This makes it easier to exit the vehicle and rescue the occupants.

The crash-responsive EASY-EXIT feature is only operational if the EASY-EXIT/ENTRY feature is activated in the on-board computer. (> page 285)

Mirrors

Rear-view mirror

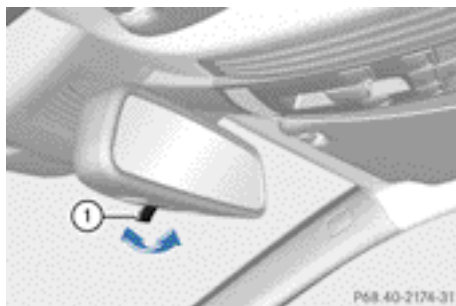

- ▶ **Anti-dazzle mode:** flick anti-dazzle switch ① forwards or back.

Exterior mirrors

Adjusting the exterior mirrors

WARNING

You could lose control of the vehicle while driving if you:

- adjust the driver's seat, steering wheel or mirrors
- fasten the seat belt

There is a risk of an accident.

Adjust the driver's seat, head restraint, steering wheel and mirrors and fasten your seat belt before starting the engine.

WARNING

The exterior mirrors reduce the size of the image. Objects visible in the mirrors are closer than they appear. You could misjudge the distance from road users driving behind you when changing lanes, for instance. There is a risk of an accident.

You should therefore always look over your shoulder to determine the actual distance from road users driving behind you.

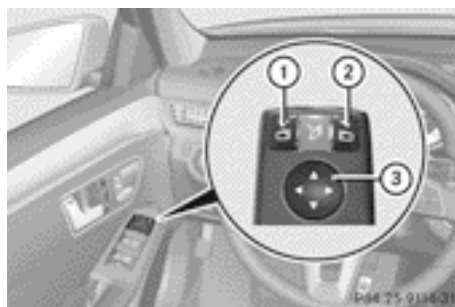

- ▶ Turn the key to position 1 or 2 in the ignition lock (> page 177).
- ▶ Press button ① for the left-hand exterior mirror or button ② for the right-hand exterior mirror.
The indicator lamp in the corresponding button lights up in red.
The indicator lamp goes out again after some time. You can adjust the selected

mirror using adjustment button ③ as long as the indicator lamp is lit.

- ▶ Press adjustment button ③ up, down, or to the left or right until you have adjusted the exterior mirror to the correct position. You should have a good overview of traffic conditions.

The convex exterior mirrors provide a larger field of vision.

After the engine has been started, the exterior mirrors are automatically heated if the rear window heating is switched on and the outside temperature is low. Heating takes a maximum of ten minutes.

- ❗ The exterior mirrors can also be heated manually by switching on the rear window heating.

Folding the exterior mirrors in/out electrically



- ▶ Turn the key to position **1** or **2** in the ignition lock (▷ page 177).
 - ▶ Briefly press button ①.
- Both exterior mirrors fold in or out.
- ❗ Make sure that the exterior mirrors are always folded out fully while driving. They could otherwise vibrate.
 - ❗ If you are driving faster than 47 km/h, you can no longer fold in the exterior mirrors.

Setting the exterior mirrors

If the battery has been disconnected or completely discharged, the exterior mirrors must

be reset. The exterior mirrors will otherwise not fold in when you select the "Fold in mirrors when locking" function in the on-board computer (▷ page 286)

- ▶ Turn the key to position **1** in the ignition lock (▷ page 177).
- ▶ Briefly press button ①.

Folding the exterior mirrors in/out automatically

If the "Fold in mirrors when locking" function is activated in the on-board computer (▷ page 286):

- the exterior mirrors fold in automatically as soon as you lock the vehicle from the outside.
- the exterior mirrors fold out again automatically as soon as you unlock the vehicle and then open the driver's or front-passenger door.

- ❗ If the exterior mirrors have been folded in manually, they do not fold out.

Exterior mirror pushed out of position

If an exterior mirror has been pushed out of position (forwards or backwards), proceed as follows.

- ▶ **Vehicles without electrically folding exterior mirrors:** move the exterior mirror into the correct position manually.
- ▶ **Vehicles with electrically folding exterior mirrors:** press and hold mirror-folding button ① until you hear a click and the mirror engages audibly into position (▷ page 130).
The mirror housing is engaged again and you can adjust the exterior mirrors as usual (▷ page 129).

Automatic anti-dazzle mirrors

The rear-view mirror and the exterior mirror on the driver's side automatically go into anti-dazzle mode if the following conditions are met simultaneously:

- the ignition is switched on and
- incident light from headlamps strikes the sensor in the rear-view mirror

The mirrors do not dip if reverse gear is engaged or if the interior lighting is switched on.

Parking position of the exterior mirror on the front-passenger side

Setting and storing the parking position

Using reverse gear

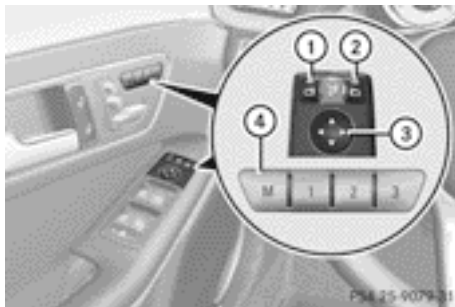

- ① Button for the exterior mirror on the driver's side
- ② Button for the exterior mirror on the front-passenger side
- ③ Adjustment button
- ④ Memory button **M**

You can set the front-passenger side exterior mirror so that you can see the rear wheel on that side as soon as you engage reverse gear. You can store this position.

- ▶ Stop the vehicle and turn the key to position **2** in the ignition lock (▷ page 177).
- ▶ Press button ② for the exterior mirror on the front-passenger side.

- ▶ Engage reverse gear.

The exterior mirror on the front-passenger side moves to the preset parking position.

- ▶ Use adjustment button ③ to adjust the exterior mirror to a position that allows you to see the rear wheel and the kerb. The parking position is stored.

- ❗ If you shift the transmission to another position, the exterior mirror on the front-passenger side returns to the driving position.

Using the memory button

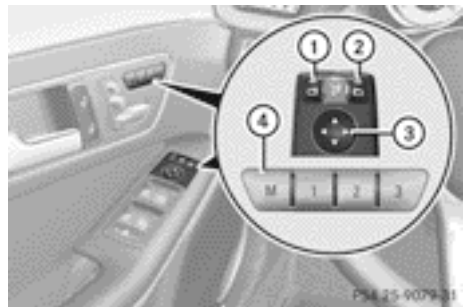

- ① Button for the exterior mirror on the driver's side
- ② Button for the exterior mirror on the front-passenger side
- ③ Adjustment button
- ④ Memory button **M**

You can set the front-passenger side exterior mirror so that you can see the rear wheel on that side as soon as you engage reverse gear. This setting can be stored using memory button **M** ④.

- ▶ Turn the key to position **2** in the ignition lock (▷ page 177).
- ▶ With the exterior mirror on the front-passenger side activated, use adjustment button ③ to adjust the exterior mirror. The rear wheel and the kerb should be visible in the exterior mirror.

- ▶ Press memory button **M** ④ and one of the arrows on adjustment button ③ within three seconds.

The parking position is stored if the exterior mirror does not move.

- ▶ If the exterior mirror moves out of position, repeat the steps.

Calling up a stored parking position setting

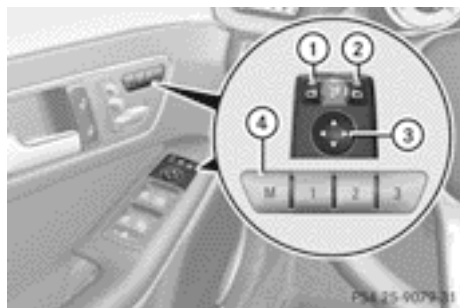

- ① Button for the exterior mirror on the driver's side
- ② Button for the exterior mirror on the front-passenger side
- ③ Adjustment button
- ④ Memory button **M**

- ▶ Turn the key to position **2** in the ignition lock (▷ page 177).
 - ▶ Adjust the exterior mirror on the front-passenger side using button ②.
 - ▶ Engage reverse gear.
- The exterior mirror on the front-passenger side moves to the stored parking position.

The exterior mirror on the front-passenger side moves back to its original position:

- as soon as you exceed a speed of 15 km/h
- if you press button ① for the exterior mirror on the driver's side

Memory function

Storing settings

WARNING

If you use the memory function on the driver's side while driving, the adjustments could cause you to lose control of the vehicle. There is a risk of an accident.

Only use the memory function on the driver's side while the vehicle is stationary.

WARNING

If children activate the memory function, they could become trapped, especially if they are unattended. There is a risk of injury.

When leaving the vehicle, always take the key with you and lock the vehicle. Never leave children unattended in the vehicle.

With the memory function, you can store up to three different settings, e.g. for three different people.

The following settings are stored as a single memory preset:

- position of the seat, backrest and head restraint.
- active multicontour seat: seat contour, dynamic function level
- driver's side: position of the exterior mirrors on the driver's and front-passenger sides



- ▶ Adjust the seat (▷ page 116).
- ▶ On the driver's side, adjust the steering wheel (▷ page 127) and the exterior mirrors (▷ page 129).
- ▶ Press memory button **M** and then press storage position button **1**, **2** or **3** within three seconds.

The settings are stored in the selected pre-set position. A tone sounds when the settings have been completed.

Calling up a stored setting

- ▶ Press and hold the relevant storage position button **1**, **2** or **3**, until the seat, steering wheel and exterior mirrors are in the stored position.
- i** The setting procedure is interrupted as soon as you release the storage position button.

Useful information	136
Exterior lighting	136
Interior lighting	146
Replacing bulbs	147
Windscreen wipers	149

Useful information

- i** This Owner's Manual describes all models, series and optional equipment for your vehicle that were available at the time of going to press. National variations are possible. Note that your vehicle may not be equipped with all of the functions described. This is also the case for systems and functions relevant to safety.
- i** Read the information on qualified specialist workshops: (▷ page 26).

Exterior lighting

General notes

For reasons of safety, Mercedes-Benz recommends that you drive with the lights switched on even during the daytime. Therefore, your vehicle is equipped with special daytime driving lamps. In some countries, operation of the headlamps varies due to legal requirements and self-imposed obligations.

Driving abroad

General notes

If your journey takes you to countries where vehicles are driven on the opposite side of the road to the country in which the vehicle is registered, your headlamps must be switched to symmetrical dipped beam as soon as possible after crossing the border (exception: vehicles with static LED headlamps). This prevents oncoming traffic from being dazzled. Symmetrical lights do not illuminate as large an area of the edge of the carriageway.

Vehicles with static LED headlamps

It is not necessary to switch your headlamps to symmetrical dipped beam when driving in countries where vehicles are driven on the opposite side of the road to the country in which the vehicle is registered. Legal require-

ments are fulfilled without switching the headlamps to symmetrical dipped beam.

Vehicles with Intelligent Light System

- ▶ Before crossing the border, set the headlamps to symmetrical dipped beam and after returning back to asymmetrical dipped beam via the "Dipped-beam headlamps for driving on the right/left" function in the on-board computer (▷ page 282).

If the headlamps are converted to symmetrical dipped beam, the "motorway mode" and "extended range foglamps" functions are not available.

Setting the exterior lighting

Setting options

Exterior lighting can be set using the:

- light switch
- combination switch (▷ page 139)
- on-board computer (▷ page 281)

Light switch

Operation

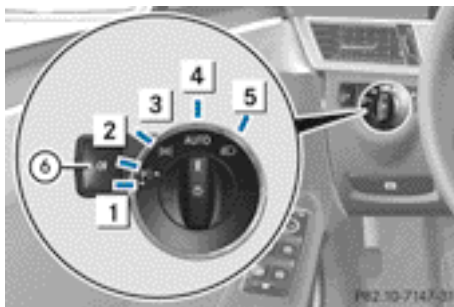

- 1** Left-hand parking lamps
- 2** Right-hand parking lamps
- 3** Side lamps, licence plate and instrument cluster lighting
- 4** **AUTO** Automatic headlamp mode, controlled by the light sensor

5  Dipped-beam/main-beam headlamps

6  Rear fog lamp

If you hear a warning tone when you leave the vehicle, the lights may still be switched on.

► Turn the light switch to **AUTO**.

The exterior lighting (except the side lamps/parking lamps) switches off automatically if you:

- remove the key from the ignition lock
- open the driver's door with the key in position **0**

Automatic headlamp mode

WARNING

When the light switch is set to **AUTO**, the dipped-beam headlamps may not be switched on automatically if there is fog, snow or other causes of poor visibility due to the weather conditions such as spray. There is a risk of an accident.

In such situations, turn the light switch to



The automatic headlamp feature is only an aid. The driver is responsible for the vehicle lighting at all times.

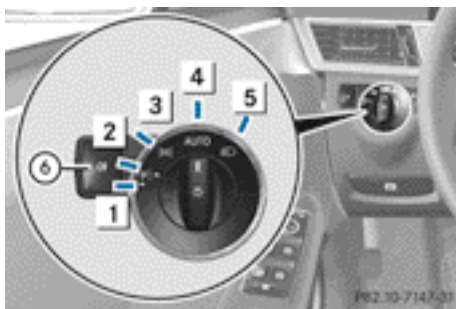

1  Left-hand parking lamps

2  Right-hand parking lamps

3  Side lamps, licence plate and instrument cluster lighting

4 **AUTO** Automatic headlamp mode, controlled by the light sensor

5  Dipped-beam/main-beam headlamps



6  Rear fog lamp

AUTO is the preferred light switch setting. The light setting is automatically selected according to the brightness of the ambient light (exception: poor visibility due to weather conditions such as fog, snow or spray):

- Key in position **1** in the ignition lock: the side lamps are switched on or off automatically depending on the brightness of the ambient light.
- With the engine running: if you have switched on the daytime driving lights function in the on-board computer, the daytime driving lights or the side lamps and dipped-beam headlamps are switched on or off automatically depending on the brightness of the ambient light.

► **To switch on automatic headlamp mode:** turn the light switch to **AUTO**.

The daytime driving lights improve the detectability of your vehicle during the day. Here, the daytime driving lights function must be switched on via the on-board computer (► page 281).

When the side lamps and dipped-beam headlamps are switched on, the green  (side lamps) and  (dipped-beam headlamps) indicator lamps in the instrument cluster light up.

Dipped-beam headlamps

WARNING

When the light switch is set to **AUTO**, the dipped-beam headlamps may not be switched on automatically if there is fog, snow or other causes of poor visibility due to the weather conditions such as spray. There is a risk of an accident.

In such situations, turn the light switch to



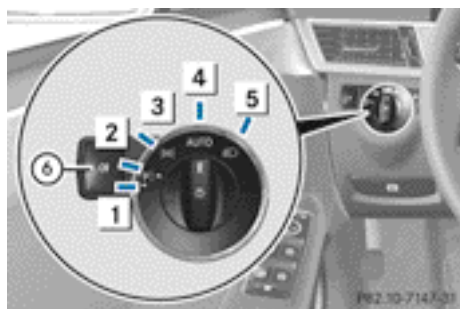

- 1 Left-hand parking lamps
- 2 Right-hand parking lamps
- 3 Side lamps, licence plate and instrument cluster lighting
- 4 **AUTO** Automatic headlamp mode, controlled by the light sensor
- 5 Dipped-beam/main-beam headlamps
- 6 Rear fog lamp

When the ignition is switched on and the light switch is in position , the side lamps and dipped-beam headlamps are switched on even if the light sensor does not sense dark ambient light conditions. This is advantageous when there is fog or rain.

- ▶ **To switch on the dipped-beam headlamps:** turn the key in the ignition lock to position **2** or start the engine.
- ▶ Turn the light switch to . The green indicator lamp in the instrument cluster lights up.

Rear foglamp

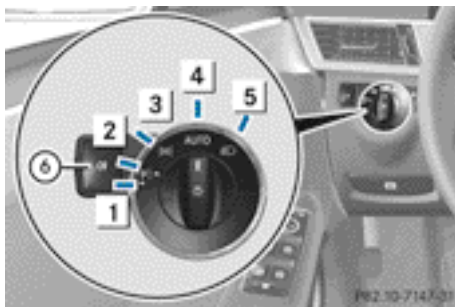



- 1 Left-hand parking lamps
- 2 Right-hand parking lamps
- 3 Side lamps, licence plate and instrument cluster lighting
- 4 **AUTO** Automatic headlamp mode, controlled by the light sensor
- 5 Dipped-beam/main-beam headlamps
- 6 Rear fog lamp

The rear foglamp improves the visibility of your vehicle in heavy fog for the following traffic. Please observe the country-specific laws on the use of rear foglamps.





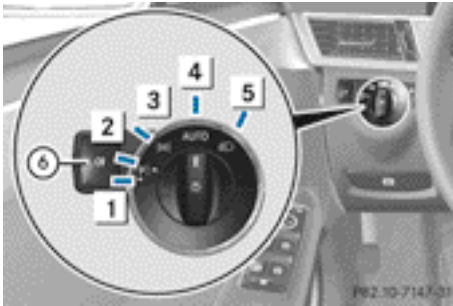

- ▶ **To switch on the rear foglamp:** turn the key in the ignition lock to position **2** or start the engine.
- ▶ Turn the light switch to or **AUTO**.
- ▶ Press the button. The yellow indicator lamp in the instrument cluster lights up.
- ▶ **To switch off the rear foglamp:** press the button. The yellow indicator lamp in the instrument cluster goes out.

Side lamps

- If the battery has been excessively discharged, the side lamps or parking lamps are automatically switched off to enable the next engine start. Always park your vehicle safely and sufficiently lit according to legal standards. Avoid the continuous use of the side lamps for several

hours. If possible, switch on the  right or the  left parking lamp.







- 1  Left-hand parking lamps
- 2  Right-hand parking lamps
- 3  Side lamps, licence plate and instrument cluster lighting
- 4  Automatic headlamp mode, controlled by the light sensor
- 5  Dipped-beam/main-beam headlamps
- 6  Rear foglamp

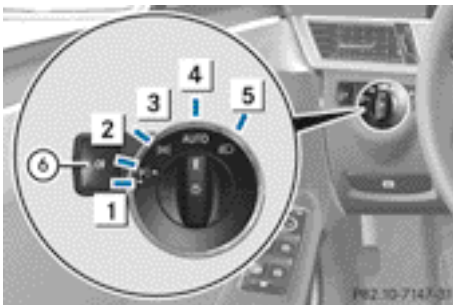

► **To switch on:** turn the light switch to .

The green  indicator lamp in the instrument cluster lights up.



Parking lamps



- 1  Left-hand parking lamps
- 2  Right-hand parking lamps
- 3  Side lamps, licence plate and instrument cluster lighting
- 4  Automatic headlamp mode, controlled by the light sensor

- 5  Dipped-beam/main-beam headlamps
- 6  Rear foglamp





Switching on the parking lamps ensures that the corresponding side of the vehicle is illuminated.

- **To switch on the parking lamps:** the key is not in the ignition lock or it is in position 0.
- Turn the light switch to  (left-hand side of the vehicle) or  (right-hand side of the vehicle).

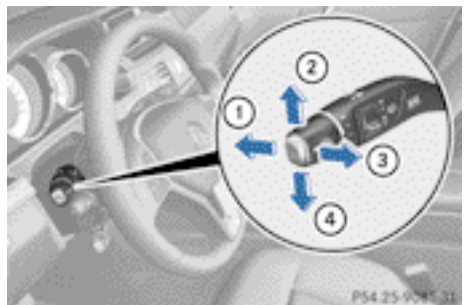
Combination switch

Turn signals



- 1  Main-beam headlamps
- 2  Turn signal, right
- 3  Headlamp flasher
- 4  Turn signal, left

► **To indicate briefly:** press the combination switch briefly to the pressure point in the direction of arrow ② or ④.

The corresponding turn signal flashes three times.

► **To indicate:** press the combination switch beyond the pressure point in the direction of arrow ② or ④.

Main-beam headlamps

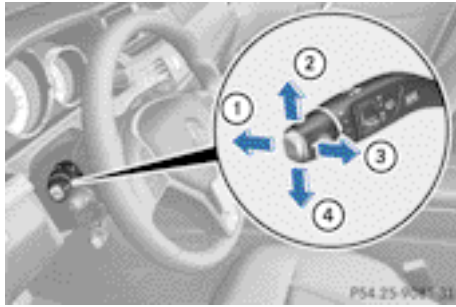

- ① Main-beam headlamps
- ② Turn signal, right
- ③ Headlamp flasher
- ④ Turn signal, left

► **To switch on the main-beam headlamps:** turn the key in the ignition lock to position **2** or start the engine.

► Turn the light switch to  or **AUTO**.

► Press the combination switch beyond the pressure point in the direction of arrow **①**.

In the **AUTO** position, the main-beam headlamps are only switched on when it is dark and the engine is running.

The blue  indicator lamp in the instrument cluster lights up when the main-beam headlamps are switched on.

► **To switch off the main-beam headlamps:** move the combination switch back to its normal position.

The blue  indicator lamp in the instrument cluster goes out.

i Vehicles with Adaptive Highbeam Assist: when Adaptive Highbeam Assist is active, it controls activation of the main-beam headlamps (► page 142).

Headlamp flasher

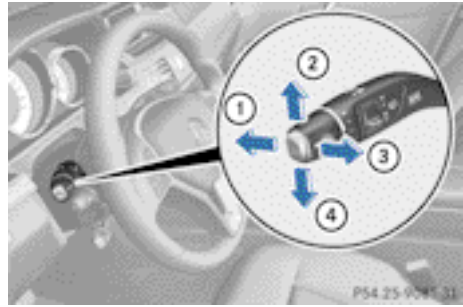

- ① Main-beam headlamps
- ② Turn signal, right
- ③ Headlamp flasher
- ④ Turn signal, left

► **To switch on:** turn the key in the ignition lock to position **1** or **2**, or start the engine.

► Pull the combination switch in the direction of arrow **③**.

Hazard warning lamps



► **To switch on the hazard warning lamps:** press button **①**.

All turn signals flash. If you now switch on a turn signal using the combination switch, only the turn signal lamp on the corresponding side of the vehicle will flash.

► **To switch off the hazard warning lamps:** press button **①**.

The hazard warning lamps switch on automatically if:

- an airbag is deployed or
- the vehicle decelerates rapidly from a speed of above 70 km/h and comes to a standstill

The hazard warning lamps switch off automatically if the vehicle reaches a speed of above 10 km/h again after a full brake application.

- i** The hazard warning lamps still operate if the ignition is switched off.

Intelligent Light System

General notes

The Intelligent Light System is a system that adjusts the headlamps automatically to suit the prevailing driving and weather conditions. It offers advanced functions for improved illumination of the road surface, e.g. depending on the vehicle speed or weather conditions. The system includes the active light function, cornering light function, motorway mode and extended range foglamps. The system is only active when it is dark.

You can activate or deactivate the "Intelligent Light System" using the on-board computer (▷ page 282).

Active light function

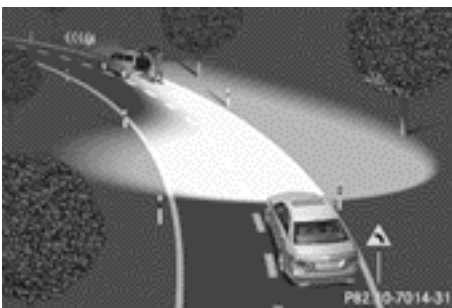

The active light function is a system that moves the headlamps according to the steering movements of the front wheels. In this

way, relevant areas remain illuminated while driving. This allows you to recognise pedestrians, cyclists and animals.

Active: when the lights are switched on.

Cornering light function

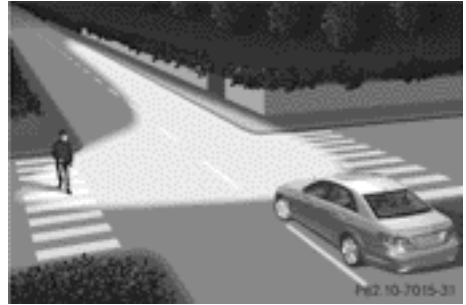

The cornering light function improves the illumination of the road over a wide angle in the direction you are turning, enabling better visibility in tight bends, for example. It can only be activated when the dipped-beam headlamps are switched on.

Active:

- if you are driving at speeds below 40 km/h and switch on the turn signal or turn the steering wheel
- if you are driving at speeds between 40 km/h and 70 km/h and turn the steering wheel

Not active: if you are driving at speeds above 40 km/h or switch off the turn signal or turn the steering wheel to the straight-ahead position.

The cornering lamp may remain lit for a short time, but is automatically switched off after no more than three minutes.

Motorway mode



Active: if you are driving at a speed above 110 km/h and do not make any large steering movements for at least 1,000 m or if you are driving at a speed above 130 km/h.

Not active: if you are driving at speeds below 80 km/h following activation.

Extended range foglamps

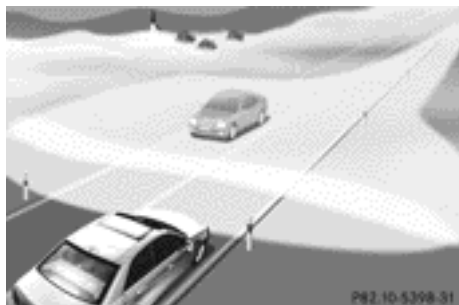

The extended range foglamps reduce the glare experienced by the driver and improve the illumination of the edge of the carriageway.

Active: if you are driving at speeds below 70 km/h and you switch on the rear foglamp.

Not active: if, following activation, you are driving at speeds above 100 km/h or if you switch off the rear foglamp.

Adaptive Highbeam Assist

Important safety notes

WARNING

Adaptive Highbeam Assist does not recognise road users:

- who have no lights, e.g. pedestrians
- who have poor lighting, e.g. cyclists
- whose lighting is blocked, e.g. by a barrier

In very rare cases, Adaptive Highbeam Assist recognises road users too late or not at all. In this, or in similar situations, the automatic main-beam headlamps will not be deactivated or activated regardless. There is a risk of an accident.

Always carefully observe the traffic conditions and switch off the main-beam headlamps in good time.

Adaptive Highbeam Assist cannot take into account road, weather or traffic conditions. Adaptive Highbeam Assist is only an aid. You are responsible for adjusting the vehicle's lighting to the prevailing light, visibility and traffic conditions.

In particular, the detection of obstacles can be restricted if there is:

- poor visibility, e.g. due to fog, heavy rain or snow
- dirt on the sensors or if the sensors are obscured

General notes

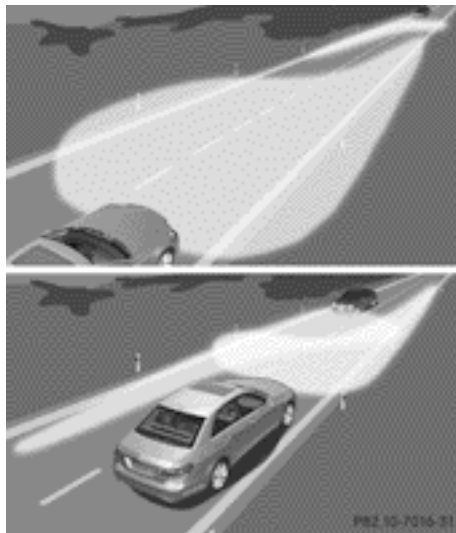

You can use this function to set the headlamps to change between dipped beam and main beam automatically. The system recognises vehicles with their lights on, either approaching from the opposite direction or travelling in front of your vehicle, and consequently switches the headlamps from main beam to dipped beam.

The system automatically adapts the dipped-beam headlamp range depending on the distance to the other vehicle. Once the system no longer detects any other vehicles, it switches on the main-beam headlamps again. The system's optical sensor is located behind the windscreen near the overhead control panel.

Switching Adaptive Highbeam Assist on/off

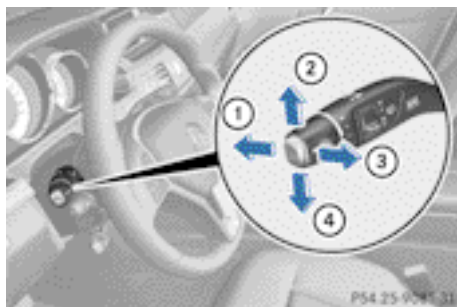

- ① Main-beam headlamps
- ② Turn signal, right
- ③ Headlamp flasher
- ④ Turn signal, left

► **To switch on:** turn the light switch to **AUTO**.

► Press the combination switch beyond the pressure point in the direction of arrow ①.

The  indicator lamp in the multifunction display lights up when it is dark and the light sensor activates the dipped-beam headlamps.



If you are driving at speeds above 25 km/h:

the headlamp range is set automatically depending on the distance between the vehicle and other road users.

If you are driving at speeds above approximately 30 km/h and no other road users are recognised:

the main-beam headlamps are switched on automatically. The  indicator lamp in the instrument cluster also lights up.

If you are driving at speeds below 25 km/h or other road users are recognised or the roads are adequately lit:

the main-beam headlamps are switched off automatically. The  indicator lamp in the instrument cluster goes out. the 

indicator lamp in the multifunction display remains lit.

- ▶ **To switch off:** move the combination switch back to its normal position or move the light switch to another position. The  indicator lamp in the instrument cluster goes out.

Adaptive Highbeam Assist Plus

Important safety notes

WARNING

Adaptive Highbeam Assist Plus does not recognise road users:

- who have no lights, e.g. pedestrians
- who have poor lighting, e.g. cyclists
- whose lighting is blocked, e.g. by a barrier

In very rare cases, Adaptive Highbeam Assist Plus may not recognise road users who do have lights, or may recognise them too late. In this, or in similar situations, the automatic main-beam headlamps will not be deactivated or will be activated despite the presence of other road users. There is a risk of an accident.

Always carefully observe the traffic conditions and switch off the main-beam headlamps in good time.

Adaptive Highbeam Assist Plus cannot take into account road, weather or traffic conditions. Adaptive Highbeam Assist Plus is only an aid. You are responsible for adjusting the vehicle's lighting to the prevailing light, visibility and traffic conditions.

In particular, the detection of obstacles can be restricted if there is:

- poor visibility, e.g. due to fog, heavy rain or snow
- dirt on the sensors or if the sensors are obscured

General notes

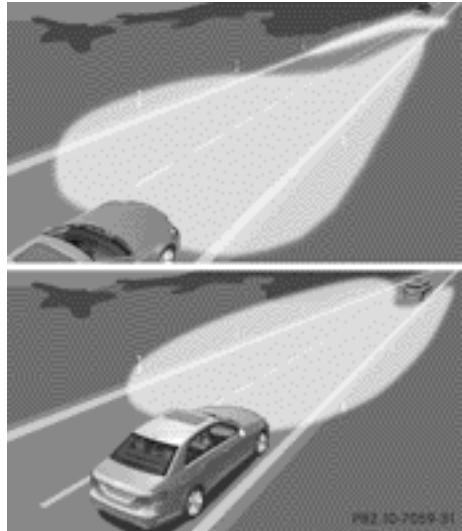

With Adaptive Highbeam Assist Plus, you can automatically switch between dipped-beam, partial main-beam and main-beam headlamps.

Partial main-beam illumination is a form of illumination whereby the main beam is directed past other road users. Other road users are thus kept out of the main beam. This prevents glare. If there is a vehicle in front, for example, the main-beam headlamps illuminate the areas to its right and left, and the vehicle in front is illuminated by the dipped-beam headlamps.

The system automatically adapts the dipped-beam headlamp range depending on the distance to the other vehicle. Once the system no longer detects any other vehicles, it switches on the main-beam headlamps again. If the main-beam or partial main-beam headlamps are causing too much reflection from traffic signs, the lights are automatically dimmed and glare for the driver caused by the reflections is thus avoided.

The system's optical sensor is located behind the windscreen near the overhead control panel.

Switching Adaptive Highbeam Assist PLUS on/off

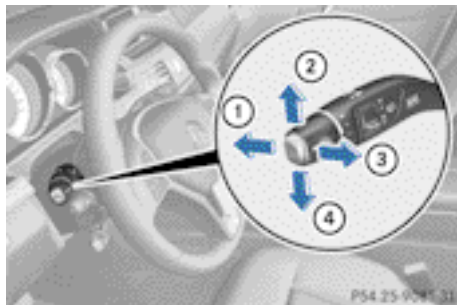

- ① Main-beam headlamps
- ② Turn signal, right
- ③ Headlamp flasher
- ④ Turn signal, left

► **To switch on:** turn the light switch to **AUTO**.

► Press the combination switch beyond the pressure point in the direction of arrow ①.

The  indicator lamp in the multifunction display lights up when it is dark and the light sensor activates the dipped-beam headlamps.

If you are driving at speeds above 25 km/h:

the headlamp range is set automatically depending on the distance between the vehicle and other road users.

If you are driving at speeds above approximately 30 km/h and no other road users are recognised:

the main-beam headlamps are switched on automatically. The  indicator lamp in the instrument cluster also lights up.



If you are driving at speeds above 45 km/h and other road users are recognised:

the partial main-beam headlamps are switched on automatically. The  indicator lamp in the instrument cluster also lights up.

If you are driving at speeds below approximately 40 km/h:

the partial main-beam headlamps are switched off automatically. If no other road users are recognised, the main-beam headlamps are switched on.

If you are driving at speeds below approximately 25 km/h or the roads are adequately illuminated:

the main-beam headlamps are switched off automatically. The  indicator lamp in the instrument cluster goes out. The  indicator lamp in the multifunction display remains lit.

► **To switch off:** move the combination switch back to its normal position or move the light switch to another position. The  indicator lamp in the instrument cluster goes out.

Headlamps misted up on the inside

The headlamps may mist up on the inside if there is high atmospheric humidity.

► Switch on the lights and drive off.

The level of moisture diminishes, depending on the length of the journey and the weather conditions (humidity and temperature).

If the level of moisture does not diminish:



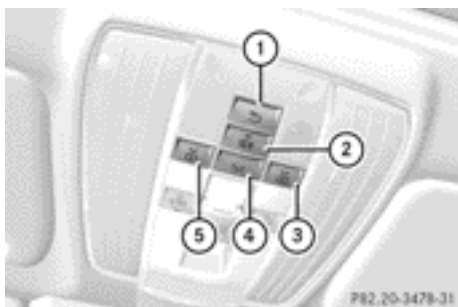

► Have the headlamps checked at a qualified specialist workshop.

Interior lighting

Overview of interior lighting



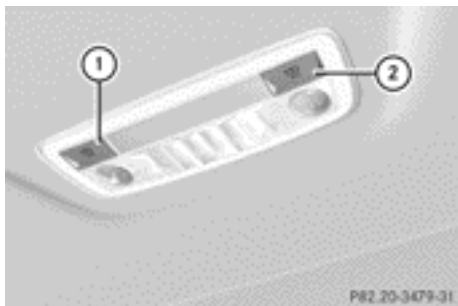

Front overhead control panel

- ①  Switches the rear interior lighting on/off
- ②  Switches the automatic interior lighting control on/off
- ③  Switches the right-hand front reading lamp on/off
- ④  Switches the front interior lighting on/off
- ⑤  Switches the left-hand front reading lamp on/off



Rear-compartment overhead control panel

- ①  Switches the right-hand reading lamp on/off
- ②  Switches the left-hand reading lamp on/off

Interior lighting control

General notes



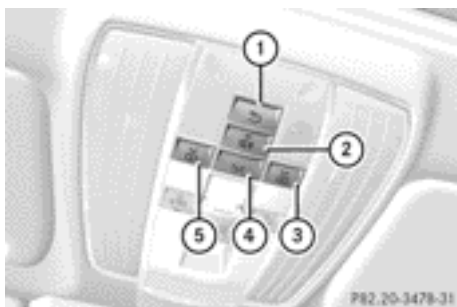

In order to prevent the vehicle's battery from discharging, the interior lighting functions are automatically deactivated after some time except for when the key is in position **2** in the ignition lock.

The colour and brightness of the ambient lighting may be set using the on-board computer (▷ page 282).

Automatic interior lighting control



Front overhead control panel

- ①  Switches the rear interior lighting on/off
- ②  Switches the automatic interior lighting control on/off
- ③  Switches the right-hand reading lamp on/off
- ④  Switches the front interior lighting on/off
- ⑤  Switches the left-hand reading lamp on/off

► **To switch on/off:** press the  button. When the automatic interior lighting control is activated, the button is flush with the overhead control panel.

The interior lighting automatically switches on if you:



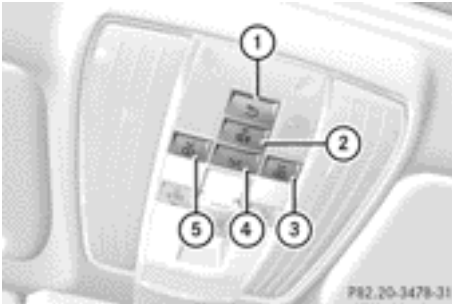

- unlock the vehicle
- open a door
- remove the key from the ignition lock

The interior lighting is activated for a short time when the key is removed from the ignition lock. You can activate this delayed switch-off using the on-board computer (▷ page 283).

Manual interior lighting control



Front overhead control panel

- ①  Switches the rear interior lighting on/off
- ②  Switches the automatic interior lighting control on/off
- ③  Switches the right-hand reading lamp on/off
- ④  Switches the front interior lighting on/off
- ⑤  Switches the left-hand reading lamp on/off

► **To switch the front interior lighting on/off:** press the  button.

► **To switch the rear interior lighting on/off:** press the  button.

► **To switch the reading lamps on/off:** press the  button.

Crash-responsive emergency lighting

The interior lighting is activated automatically if the vehicle is involved in an accident.

► **To switch off the crash-responsive emergency lighting:** press the hazard warning lamp button.

or

► Lock and then unlock the vehicle using the key.

Replacing bulbs

Important safety notes

WARNING

Bulbs, lamps and plug connectors can become very hot during use. When replacing a bulb, you could burn yourself on these components. There is a risk of injury.

Allow these components to cool down before replacing the bulb.

Vehicles with static LED headlamps:

Do not use a bulb that has been dropped or if its glass tube has been scratched.

The bulb may explode if:

- you touch it
- it is hot
- you drop it
- you scratch it

Only operate bulbs in enclosed lamps designed for that purpose. Only fit spare bulbs of the same type and the specified voltage.

Marks on the glass tube reduce the service life of the bulbs. Do not touch the glass tube with your bare hands. If necessary, clean the glass tube when cold with alcohol or spirit and rub it off with a lint-free cloth.

Protect bulbs from moisture during operation. Do not allow bulbs to come into contact with liquids.

Replace only the bulbs listed (▷ page 148). Have the bulbs that you cannot replace your-

self replaced at a qualified specialist workshop.

If you require assistance replacing bulbs, consult a qualified specialist workshop.

If the new bulb still does not light up, consult a qualified specialist workshop.

Bulbs and lamps are an important aspect of vehicle safety. You must therefore make sure that these function correctly at all times.

Have the headlamp setting checked regularly.

Vehicles with Intelligent Light System

The front and rear light clusters of your vehicle are equipped with LED light bulbs. Do not replace the bulbs yourself. Contact a qualified specialist workshop which has the necessary specialist knowledge and tools to carry out the work required.

Lamps are an important aspect of vehicle safety. You must therefore make sure that these function correctly at all times. Have the headlamp setting checked regularly.

Overview of bulb replacement – bulbs

You can replace the following bulbs. The details for the bulb type can be found in the legend.

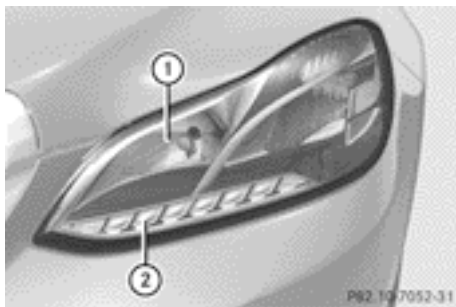

Static LED headlamps

- ① Main-beam headlamp: H7 55 W
- ② Turn signal lamp: PSY 24 W

Replacing the front bulbs

Main-beam headlamps (static LED headlamps)

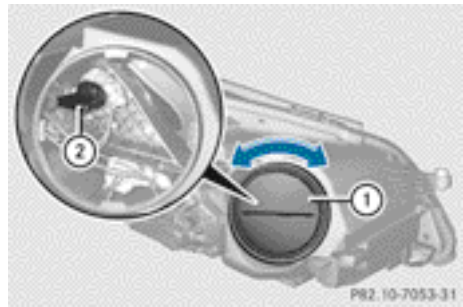

- ▶ Switch off the lights.
- ▶ Open the bonnet.
- ▶ Turn housing cover ① anti-clockwise and pull it out.
- ▶ Using the handle extension, turn bulb holder ② anti-clockwise and pull it out.
- ▶ Take the bulb out of bulb holder ②.
- ▶ Insert the new bulb into bulb holder ②.
- ▶ Insert bulb holder ② into the lamp and turn it clockwise.
- ▶ Align housing cover ① and turn it clockwise until it engages.

Turn signal lamps (static LED headlamps)

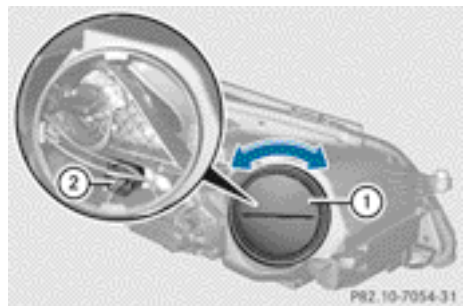

- ▶ Switch off the lights.
- ▶ Open the bonnet.

- ▶ Turn housing cover ① anti-clockwise and pull it out.
- ▶ Turn bulb holder ② anti-clockwise and pull it out.
- ▶ Take the bulb out of bulb holder ②.
- ▶ Insert the new bulb into bulb holder ②.
- ▶ Insert bulb holder ② into the lamp and turn it clockwise.
- ▶ Align housing cover ① and turn it clockwise.

Windscreen wipers

Switching the windscreen wipers on/off

! Do not operate the windscreen wipers when the windscreen is dry, as this could damage the wiper blades. Moreover, dust that has collected on the windscreen can scratch the glass if wiping takes place when the windscreen is dry.

If it is necessary to switch on the windscreen wipers in dry weather conditions, always operate them using washer fluid.

! If the windscreen wipers leave smears on the windscreen after the vehicle has been washed in an automatic car wash, this may be due to wax or other residue. Clean the windscreen with washer fluid after an automatic car wash.

! Intermittent wiping with rain sensor: due to optical influences and the windscreen becoming dirty in dry weather conditions, the windscreen wipers may be activated inadvertently. This could damage the windscreen wiper blades or scratch the windscreen.

For this reason, you should always switch off the windscreen wipers in dry weather.

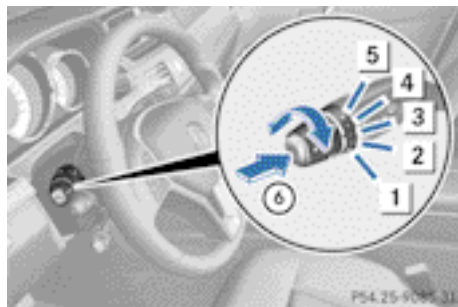

Combination switch

- 1 0 Windscreen wipers off
- 2 ... Intermittent wipe, low (rain sensor set to low sensitivity)
- 3 Intermittent wipe, high (rain sensor set to high sensitivity)
- 4 — Continuous wipe, slow
- 5 == Continuous wipe, fast
- 6 [Washer fluid icon] Single wipe / [Washer fluid icon] to wipe the windscreen using washer fluid

▶ Turn the key to position **1** or **2** in the ignition lock.

▶ Turn the combination switch to the corresponding position.

In the ... or position, the appropriate wiping frequency is set automatically according to the intensity of the rain. In the position, the rain sensor is more sensitive than in the ... position, causing the windscreen wipers to wipe more frequently.

If the wiper blades are worn, the windscreen will no longer be wiped properly. This could prevent you from observing the traffic conditions. Replace the wiper blades twice a year, ideally in spring and autumn.

Switching the rear window wiper on/off

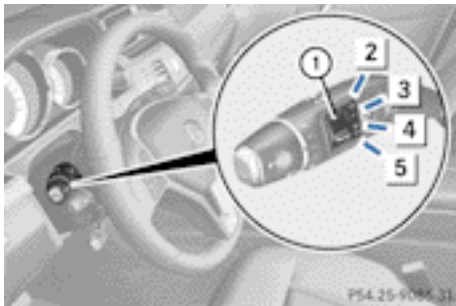

Combination switch

- ① Switch
- 2 To wipe with washer fluid
- 3 **I** To switch on intermittent wiping
- 4 **0** To switch off intermittent wiping
- 5 To wipe with washer fluid

- ▶ Turn the key to position **1** or **2** in the ignition lock.
- ▶ Turn switch ① on the combination switch to the corresponding position. When the rear window wiper is switched on, the icon appears in the instrument cluster.

Replacing the wiper blades

Important safety notes

WARNING

If the windscreen wipers begin to move while you are changing the wiper blades, you can be trapped by the wiper arm. There is a risk of injury.

Always switch off the windscreen wipers and ignition before changing the wiper blades.

- !** To avoid damaging the windscreen wiper blades, make sure that you touch only the wiper arm of the windscreen wiper.
- !** Never open the bonnet/tailgate if a wiper arm is folded away from the windscreen/rear window.

Never fold a windscreen wiper arm without a wiper blade back onto the windscreen/rear window.

Hold the windscreen wiper arm firmly when you change the wiper blade. If you release the wiper arm without a wiper blade and it falls onto the windscreen/rear window, the windscreen/rear window may be damaged by the force of the impact.

Mercedes-Benz recommends that you have the wiper blades changed at a qualified specialist workshop.

Depending on the equipment level of your vehicle, there are two variants of wiper blade; these are fitted and removed in different ways. Based on the diagrams, check which system is fitted in your vehicle.

Replacing the wiper blades (version 1)

Removing the wiper blades

- ▶ Remove the key from the ignition lock or turn the key to position **0** (KEYLESS-GO).
- ▶ Fold the wiper arm away from the windscreen until it engages.
- ▶ Set the wiper blade at right angles to the wiper arm.

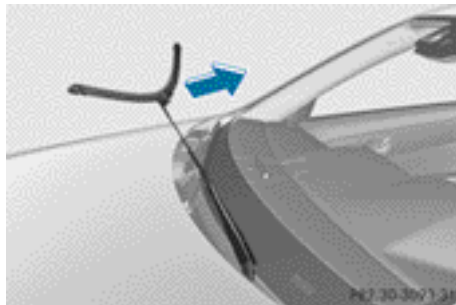

- ▶ Remove the wiper blade from the retaining pin on the wiper arm in the direction of the arrow.

Fitting the wiper blades

- ▶ Push the new wiper blade onto the retaining pin on the wiper arm in the opposite direction to the arrow.

Make sure that the wiper blade slides fully onto the retaining pin on the wiper arm.

- ▶ Turn the wiper blade parallel to the wiper arm.
- ▶ Fold the wiper arm back onto the windscreen.

Replacing the wiper blades (version 2)

Removing the wiper blades

- ▶ Remove the key from the ignition lock or turn the key to position **0** (KEYLESS-GO).
- ▶ Fold the wiper arm away from the windscreen until it engages.

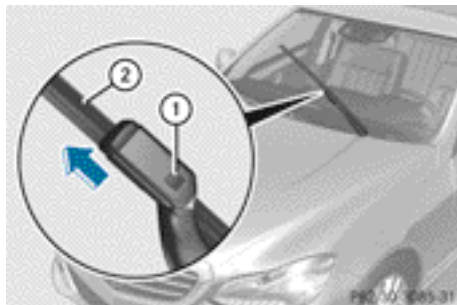

- ▶ Firmly press release knob (1) and pull wiper blade (2) upwards from the wiper arm in the direction of the arrow.

Fitting the wiper blades

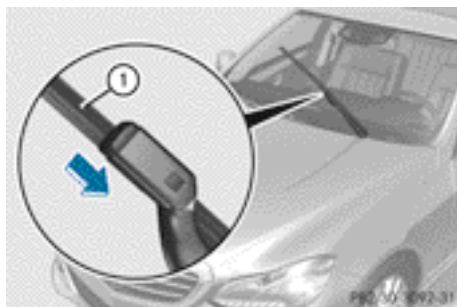

- ▶ Position new wiper blade (1) in the retainer on the wiper arm and slide it into place in the direction of the arrow. The wiper blade audibly engages.
- ▶ Make sure that wiper blade is seated correctly.
- ▶ Fold the wiper arm back onto the windscreen.

Replacing the rear window wiper blade

Removing the wiper blades

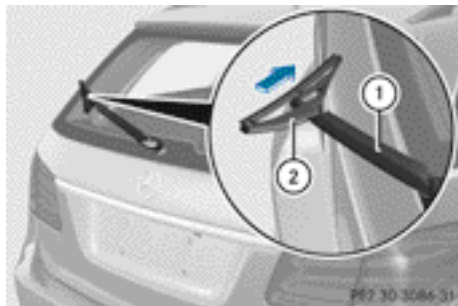

- ▶ Remove the key from the ignition lock.
- ▶ Fold wiper arm (1) away from the rear window until it engages.
- ▶ Position wiper blade (2) at a right angle to wiper arm (1).
- ▶ Hold wiper arm (1) and press wiper blade (2) in the direction of the arrow until it releases.
- ▶ Remove wiper blade (2).

Fitting a wiper blade

- ▶ Place new wiper blade (2) onto wiper arm (1).
- ▶ Hold wiper arm (1) and press wiper blade (2) in the opposite direction to the arrow until it engages.
- ▶ Make sure that wiper blade (2) is seated correctly.

- ▶ Position wiper blade ② parallel to wiper arm ①.
- ▶ Fold wiper arm ① back onto the rear window.

Problems with the windscreen wipers	
Problem	Possible causes/consequences and ► Solutions
The windscreen wipers are jammed.	<p>Leaves or snow, for example, may be obstructing the windscreen wiper movement. The wiper motor has been deactivated.</p> <ul style="list-style-type: none"> ► For safety reasons, you should remove the key from the ignition lock. <p>or</p> <ul style="list-style-type: none"> ► Switch off the engine using the Start/Stop button and open the driver's door. ► Remove the cause of the obstruction. ► Switch the windscreen wipers back on.
The windscreen wipers fail completely.	<p>The windscreen wiper drive is malfunctioning.</p> <ul style="list-style-type: none"> ► Select another wiper speed on the combination switch. ► Have the windscreen wipers checked at a qualified specialist workshop.

Useful information	156
Overview of climate control systems	156
Operating the climate control system	160
Adjusting the air vents	172

Useful information

- i** This Owner's Manual describes all models, series and optional equipment for your vehicle that were available at the time of going to press. National variations are possible. Note that your vehicle may not be equipped with all of the functions described. This is also the case for systems and functions relevant to safety.
- i** Read the information on qualified specialist workshops: (▷ page 26).

Overview of climate control systems

Important safety notes

Observe the settings recommended on the following pages. The windows could otherwise mist up.

To prevent the windows from misting up:

- switch off climate control only briefly
- switch on air-recirculation mode only briefly
- switch on the cooling with air dehumidification function
- switch on the defrost windscreen function briefly, if required

Climate control regulates the temperature and the humidity in the vehicle interior and filters undesirable substances out of the air.

Climate control is only operational when the engine is running. Optimum operation is only achieved when the side windows and the roof are closed.

The residual heat function can only be activated or deactivated with the ignition switched off (▷ page 167).

- i** Ventilate the vehicle for a brief period during warm weather, e.g. using the convenience opening feature (▷ page 105). This will speed up the cooling process and the desired vehicle interior temperature will be reached more quickly.

- i** The integrated filter filters out most particles of dust and soot and completely filters out pollen. It also reduces gaseous pollutants and odours. A clogged filter reduces the amount of air supplied to the vehicle interior. For this reason, you should always observe the interval for replacing the filter, which is specified in the Service Booklet. As it depends on environmental conditions, e.g. heavy air pollution, the interval may be shorter than stated in the Service Booklet.
- i** It is possible that the residual heat function may be activated automatically an hour after the key has been removed. The vehicle is then ventilated for 30 minutes to dry the automatic climate control.

Control panel for THERMATIC automatic climate control (2-zone)

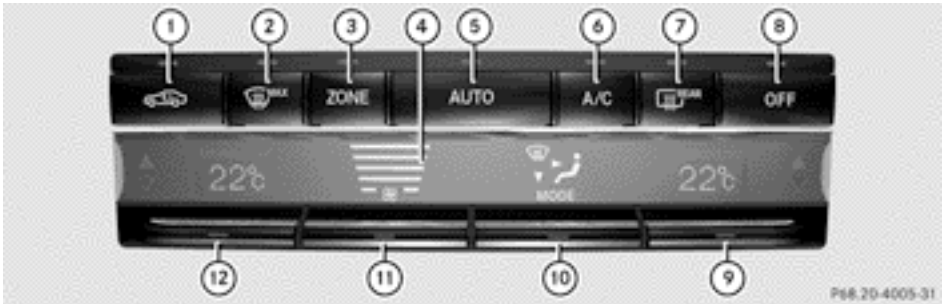

- ① To activate/deactivate air-recirculation mode (▷ page 166)
- ② To demist the windscreen (▷ page 164)
- ③ To switch the ZONE function on/off (▷ page 164)
- ④ Display
- ⑤ To set climate control to automatic mode (▷ page 162)
- ⑥ To activate/deactivate cooling with air dehumidification (▷ page 161)
- ⑦ To switch the rear window heating on/off (▷ page 165)
- ⑧ To switch climate control on/off (▷ page 160)
- ⑨ To set the temperature, right (▷ page 163)
- ⑩ To set the air distribution (▷ page 163)
- ⑪ To set the airflow (▷ page 164)
- ⑫ To set the temperature, left (▷ page 163)

Information about using THERMATIC automatic climate control

Automatic climate control

The following contains notes and recommendations on optimum use of THERMATIC automatic climate control.

- Activate climate control using the **AUTO** and **A/C** buttons. The indicator lamps above the **AUTO** and **A/C** buttons light up.
- Set the temperature to 22 °C.
- Only use the "Windscreen demisting" function briefly until the windscreen is clear again.
- Only use air-recirculation mode briefly, e.g. if there are unpleasant outside odours or when in a tunnel. The windows could otherwise mist up as no fresh air is drawn into the vehicle in air-recirculation mode.
- Use the ZONE function to adopt the temperature settings on the driver's side for the front-passenger side as well. The indicator lamp above the **ZONE** button goes out.
- **Vehicles with COMAND Online:** if you change the settings of the climate control system, the climate status display appears for approximately three seconds at the bottom of the screen in the COMAND display. See also the separate COMAND Online operating instructions. You will see the current settings of the various climate control functions.

ECO start/stop function

During automatic engine switch-off, the climate control only operates at a reduced capacity. If you require the full climate control output, you can switch off the ECO start/stop function by pressing the ECO button (> page 183).

Control panel for THERMOTRONIC automatic climate control (3-zone)

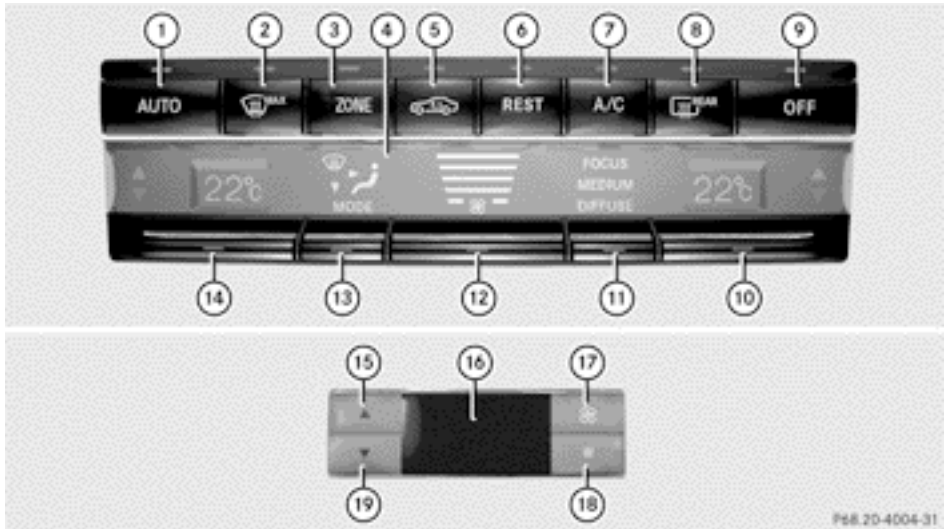
**Front control panel**

- ① To set climate control to automatic mode (▷ page 162)
- ② To demist the windscreen (▷ page 164)
- ③ To switch the ZONE function on/off (▷ page 164)
- ④ Display
- ⑤ To activate/deactivate air-recirculation mode (▷ page 166)
- ⑥ To activate/deactivate the residual heat function (▷ page 167)
- ⑦ To activate/deactivate cooling with air dehumidification (▷ page 161)
- ⑧ To switch the rear window heating on/off (▷ page 165)
- ⑨ To switch climate control on/off (▷ page 160)
- ⑩ To set the temperature, right (▷ page 163)
- ⑪ To set the climate mode (▷ page 162)
- ⑫ To set the airflow (▷ page 164)
- ⑬ To set the air distribution (▷ page 163)
- ⑭ To set the temperature, left (▷ page 163)

Rear control panel

- ⑮ To increase the temperature (▷ page 163)
- ⑯ Display
- ⑰ To increase the airflow (▷ page 164)

- ⑱ To reduce the airflow (▷ page 164)
- ⑲ To reduce the temperature (▷ page 163)

Information about using THERMOTRONIC automatic climate control

Automatic climate control

The following contains instructions and recommendations to enable you to get the most out of your THERMOTRONIC automatic climate control.

- Activate climate control using the **AUTO** and **A/C** buttons. The indicator lamps above the **AUTO** and **A/C** buttons light up.
- In automatic mode, you can also use the **AIR FLOW** button to set a climate mode (FOCUS/MEDIUM/DIFFUSE). The MEDIUM level is recommended.
- Set the temperature to 22 °C.
- Only use the "Windscreen demisting" function briefly until the windscreen is clear again.
- Only use air-recirculation mode briefly, e.g. if there are unpleasant outside odours or when in a tunnel. The windows could otherwise mist up as no fresh air is drawn into the vehicle in air-recirculation mode.
- Use the ZONE function to adopt the temperature settings on the driver's side for the front-passenger side and the rear compartment as well. The indicator lamp above the **ZONE** button goes out.
- Use the residual heat function if you want to heat or ventilate the vehicle interior when the ignition is switched off. The residual heat function can only be activated or deactivated with the ignition switched off.
- **Vehicles with COMAND Online:** if you change the settings of the climate control system, the climate status display appears for approximately three seconds at the bottom of the screen in the COMAND display. See also the separate COMAND Online

operating instructions. You will see the current settings of the various climate control functions.

ECO start/stop function

During automatic engine switch-off, the climate control only operates at a reduced capacity. If you require the full climate control output, you can switch off the ECO start/stop function by pressing the ECO button (▷ page 183).

Operating the climate control system

Switching climate control on/off

General notes

When the climate control is switched off, the air supply and air circulation are also switched off. The windows could mist up. Therefore, only switch off climate control briefly.

- ❗ Activate climate control primarily using the **AUTO** button (▷ page 162).

Activating/deactivating

- ▶ Turn the key to position **2** in the ignition lock (▷ page 177).
- ▶ **To switch on:** press the **AUTO** button on the control panel for the climate control. The indicator lamp above the **AUTO** button lights up. Airflow and air distribution are set to automatic mode.

or

- ▶ Press the **OFF** button. The indicator lamp above the **OFF** button goes out. The previous settings are reactivated.
- ▶ **To deactivate:** press the **OFF** button. The indicator lamp above the **OFF** button lights up.

Activating/deactivating the cooling with air dehumidification function

General notes

If you deactivate the "Cooling with air-dehumidification" function, the air inside the vehicle will not be cooled. The air inside the vehicle will also not be dehumidified. The windows can mist up more quickly. Therefore, only switch off cooling with air dehumidification for a short period.

The "Cooling with air dehumidification" function is only available when the engine is running. The air inside the vehicle is cooled and dehumidified according to the temperature selected.

Condensation may drip from the underside of the vehicle when cooling mode is active. This is normal and not a sign that there is a malfunction.

Activating/deactivating

- ▶ **To activate:** press the **A/C** button. The indicator lamp above the **A/C** button lights up.
 - ❗ In vehicles with auxiliary heating, one of the indicator lamps on the auxiliary heating button lights up when the "cooling with air dehumidification" function is activated.
- ▶ **To deactivate:** press the **A/C** button. The indicator lamp above the **A/C** button goes out. The "Cooling with air dehumidification" function has a delayed switch-off feature.

Problems with the "Cooling with air dehumidification" function

Problem	Possible causes/consequences and ► Solutions
The indicator lamp in the  button flashes three times or goes out. The cooling with air dehumidification system cannot be switched on.	Cooling with air dehumidification has been deactivated due to a malfunction. ► Visit a qualified specialist workshop.

Setting climate control to automatic mode



General notes

In automatic mode, the set temperature is maintained automatically at a constant level. The system automatically regulates the temperature of the dispensed air, the airflow and the air distribution.

The automatic mode functions optimally when the "Cooling with air dehumidification" function is activated. If desired, cooling with air dehumidification can be deactivated.

If you deactivate the "Cooling with air-dehumidification" function, the air inside the vehicle will not be cooled. The air inside the vehicle will also not be dehumidified. The windows can mist up more quickly. Therefore, only switch off cooling with air dehumidification for a short period.

Activating/switching

- Turn the key to position **2** in the ignition lock (► page 177).
- Set the desired temperature.
- **To activate:** press the  button.
The indicator lamp above the  button lights up. Automatic air distribution and airflow are activated.
- ❶ THERMOTRONIC automatic climate control: when automatic mode is activated, you can select a climate mode (► page 162).
- **To switch to manual operation:**

THERMATIC automatic climate control: press air distribution adjustment switch  (► page 157).

THERMOTRONIC automatic climate control: press air distribution adjustment switch  (► page 159).

The indicator lamp above the  button goes out.

or

► THERMATIC automatic climate control: press airflow adjustment switch  (► page 157).

THERMOTRONIC automatic climate control: press airflow adjustment switch  (► page 159).

The indicator lamp above the  button goes out.

Setting the climate mode

The "Set climate mode" function is only available with THERMOTRONIC automatic climate control.

In automatic mode you can select the following climate modes:

- FOCUS high airflow that is set slightly cooler
- MEDIUM medium airflow, standard setting
- DIFFUSE low airflow that is set slightly warmer and with less of a draught

- ▶ Turn the key to position **2** in the ignition lock (▷ page 177).
- ▶ Press the **AUTO** button.
- ▶ Press climate mode selection button **(11)** up or down and select the desired level (▷ page 159)

Setting the temperature

THERMATIC automatic climate control

Different temperatures can be set for the driver's and front-passenger sides.

- ▶ Turn the key to position **2** in the ignition lock (▷ page 177).
- ▶ **To increase/reduce:** press temperature adjustment switch **(9)** or **(12)** up or down (▷ page 157).

Only change the temperature setting in small increments. Start at 22 °C.

THERMOTRONIC automatic climate control

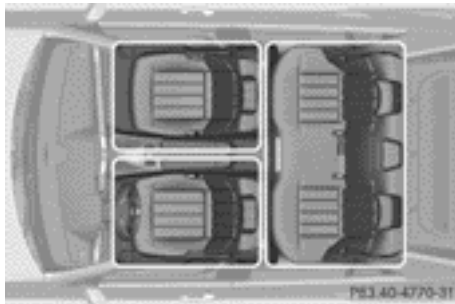

THERMOTRONIC automatic climate control zones
You can select different temperature settings for the driver's and front-passenger sides as well as for the rear compartment.

- ▶ Turn the key to position **2** in the ignition lock (▷ page 177).
- ▶ **To increase/reduce the temperature in the front compartment:** press temperature adjustment switch **(10)** or **(14)** up or down (▷ page 159).

Only change the temperature setting in small increments. Start at 22 °C.

- ▶ **To increase/reduce the temperature in the rear compartment using the front control panel:** press the **ZONE** button. The indicator lamp above the **ZONE** button goes out.
- ▶ Press temperature adjustment switch **(10)** or **(14)** up or down (▷ page 159).







Only change the temperature setting in small increments. Start at 22 °C.

- ▶ **To increase/reduce the temperature in the rear compartment using the rear control panel:** press the **▼** or **▲** button on the rear control panel.

Only change the temperature setting in small increments. Start at 22 °C.



Setting the air distribution

Air distribution settings

-  Directs the airflow through the centre and side air vents
-  Directs the airflow through the footwell air vents
-  Directs airflow through the centre and side air vents as well as the footwell air vents (only for certain countries).
-  Directs the airflow through the demister vents
-  Directs the airflow through the demister, centre and side air vents (only for certain countries).
-  Directs the airflow through the footwell and demister vents

- i** Regardless of the air distribution setting, airflow is always directed through the side air vents. The side air vents can only be closed when the controls on the side air vents are turned downwards.

To set the air distribution



- ▶ Turn the key to position **2** in the ignition lock (▷ page 177).
- ▶ THERMATIC automatic climate control: press air distribution adjustment button  up or down, until the desired symbol appears in the display (▷ page 157).
- ▶ THERMOTRONIC automatic climate control: press air distribution adjustment button  up or down, until the desired symbol appears in the display (▷ page 159).

Setting the airflow

THERMATIC automatic climate control



- ▶ Turn the key to position **2** in the ignition lock (▷ page 177).
- ▶ **To increase/reduce:** press airflow switch  up or down (▷ page 157).

THERMOTRONIC automatic climate control



- ▶ Turn the key to position **2** in the ignition lock (▷ page 177).
- ▶ **To increase/reduce front-compartment airflow:** press airflow switch  up or down (▷ page 159).
- ▶ **To increase/reduce the rear airflow:** press the  or  switch.

If the battery is not charged sufficiently, the blower output may be reduced. Once the battery is sufficiently charged again, full blower output will be available.

Switching the ZONE function on/off

- ▶ **To switch on:** press the  button. The indicator lamp above the  button lights up. THERMATIC automatic climate control: the temperature setting for the driver's side is not adopted for the front-passenger side.

THERMOTRONIC automatic climate control: the temperature setting for the driver's side is not adopted for the front-passenger side and the rear compartment.

- ▶ **To switch off:** press the  button. The indicator lamp above the  button goes out.



THERMATIC automatic climate control: the temperature setting for the driver's side is adopted for the front-passenger side.

THERMOTRONIC automatic climate control: the temperature setting for the driver's side is adopted for the front-passenger side and the rear compartment.

Demisting the windscreen

You can use this function to defrost the windscreen or to demist the inside of the windscreen and the side windows.



Switch off the "windscreen demisting" function as soon as the windscreen is clear again.

- ▶ Turn the key to position **2** in the ignition lock (▷ page 177).
- ▶ **To activate:** press the  button. The indicator lamp above the  button lights up.

The climate control system switches to the following functions:

- high airflow
- high temperature
- air distribution to the windscreen and front side windows
- air-recirculation mode off

If the battery is not charged sufficiently, the blower output may be reduced. Once the battery is sufficiently charged again, full blower output will be available again.

- ▶ **To deactivate:** press the  button. The indicator lamp above the  button goes out. The previous settings are reactivated. Air-recirculation mode remains deactivated.

or

- ▶ Press the **AUTO** button.
The indicator lamp above the  button goes out. Airflow and air distribution are set to automatic mode.

or

- ▶ THERMATIC automatic climate control: press temperature selection switch ⑨ or ⑫ up or down (▷ page 157).

THERMOTRONIC automatic climate control: press temperature selection switch ⑩ or ⑭ up or down (▷ page 159).



or

- ▶ THERMATIC automatic climate control: press airflow switch ⑪ up or down (▷ page 157).

THERMOTRONIC automatic climate control: press airflow switch ⑬ up or down (▷ page 159).



Demisting the windows



Windows misted up on the inside

- ▶ Activate the  cooling with air dehumidification function.
- ▶ Activate automatic mode **AUTO**.
- ▶ Adjust the side air vents so that the heated air is directed towards the side windows.
- ▶ If the windows continue to mist up, activate the "Windscreen demisting" function .

- i** You should only select this setting until the windscreen is clear again.

Windows misted up on the outside

- ▶ THERMATIC automatic climate control: press air distribution adjustment switch ⑩ up or down (▷ page 157), until the  or  symbol appears in the display.
- ▶ THERMOTRONIC automatic climate control: press air distribution adjustment switch ⑬ up or down (▷ page 159), until

the  or  symbol appears in the display.

- ▶ Adjust the side air vents so that no air is directed towards the side windows.



Rear window heating

General notes

The rear window heating has a high current draw. You should therefore switch it off as soon as the window is clear. It otherwise switches off automatically after several minutes.

If the battery voltage is too low, the rear window heating may switch off.

Activating/deactivating

- ▶ Turn the key to position **2** in the ignition lock (▷ page 177).
- ▶ Press the  button.
The indicator lamp above the  button lights up or goes out.

Problems with the rear window heating

Problem	Possible causes/consequences and ► Solutions
The rear window heating has switched off prematurely or cannot be activated.	The battery has not been sufficiently charged. ► Switch off any consumers that are not required, e.g. reading lamps, interior lighting or the seat heating. When the battery is sufficiently charged, the rear window heating can be activated again.

Activating/deactivating air-recirculation mode



General notes

You can deactivate the flow of fresh air if unpleasant odours are entering the vehicle from outside. The air already inside the vehicle will then be recirculated.



If you switch on air-recirculation mode, the windows can mist up more quickly, in particular at low temperatures. Only use air-recirculation mode briefly to prevent the windows misting up.

The operation of air-recirculation mode is the same for all control panels.

Activating/deactivating

- Turn the key to position **2** in the ignition lock (► page 177).
 - **To activate:** press the  button. The indicator lamp above the  button lights up.
 - i** THERMATIC automatic climate control: air-recirculation mode is activated automatically at high outside temperatures. THERMOTRONIC automatic climate control: air-recirculation mode is automatically activated at high levels of pollution or at high outside temperatures.
- When air-recirculation mode is activated automatically, the indicator lamp above the

 button does not light up. Outside air is added after about 30 minutes.

- **To deactivate:** press the  button. The indicator lamp above the  button goes out.

- i** Air-recirculation mode is deactivated automatically:
 - after approximately five minutes at outside temperatures below about 5 °C
 - after approximately five minutes if cooling with air dehumidification is deactivated
 - after approximately 30 minutes at outside temperatures above approximately 5 °C if the "Cooling with air dehumidification" function is activated

Convenience opening/closing using the air-recirculation button

WARNING



When the convenience closing feature is operating, parts of the body could become trapped in the closing area of the side window and the sliding sunroof. There is a risk of injury.

Observe the complete closing procedure when the convenience closing feature is operating. When closing make sure that no parts of the body are in the closing area.

WARNING

During convenience opening parts of the body could be drawn in or become trapped

between the side window and window frame. There is a risk of injury.





When opening, make sure that nobody is touching the side window. If someone becomes trapped, press the  switch immediately to open/close the side window in the door. The side window stops. To continue closing the side window, pull on the  switch.

- ▶ **Convenience closing feature:** press and hold the  button until the side windows and the sliding sunroof/panorama sliding sunroof are closed.

The indicator lamp above the  button lights up. Air-recirculation mode is activated.

The indicator lamp in the  button lights up. Air-recirculation mode is activated.

If parts of the body are in the closing area during convenience closing, proceed as follows:

- ▶ Press the  button for opening/closing the side windows.
The side window stops.
- ▶ To then open the side windows, press the  button again.
- ▶ Press the  button for opening/closing the sliding sunroof/panorama sliding sunroof.
The sliding sunroof/panorama sliding sunroof stops.
- ▶ To then open the sliding sunroof/panorama sliding sunroof, pull back on the  button.

- ▶ **i** Notes on the automatic reversing function for:

- the side window (▷ page 104)
- the sliding sunroof (▷ page 108)
- the panorama sliding sunroof (▷ page 108)

- ▶ **Convenience opening feature:** press and hold the  button until the side windows and the sliding sunroof/panorama

sliding sunroof are opened. The side windows and the sliding sunroof/panorama sliding sunroof move back to their original position.

The indicator lamp above the  button goes out. Air-recirculation mode is deactivated.

- ▶ **i** If you open the side windows or the sliding sunroof/panorama sliding sunroof manually after closing them with the convenience closing feature, they will remain in this position when opened using the convenience opening feature.



Activating/deactivating the residual heat function

General notes

The residual heat function is only available with THERMOTRONIC automatic climate control.

It is possible to make use of the residual heat of the engine to continue heating the vehicle for approximately 30 minutes after the engine has been switched off. The heating time depends on the temperature that has been set for the vehicle interior.

Activating/deactivating

- ▶ Turn the key to position **0** in the ignition lock or remove it (▷ page 177).
- ▶ **To activate:** press the  button.
The indicator lamp above the  button lights up.
- ▶ **i** If the residual heat function is activated, the windows may mist up on the inside.
- ▶ **i** The blower will run at a low speed regardless of the airflow setting.
- ▶ **i** If you activate the residual heat function at high temperatures, only the ventilation

will be activated. The blower runs at medium speed.

- ▶ **To deactivate:** press the **REST** button. The indicator lamp above the **REST** button goes out.

Residual heat is deactivated automatically:

- after approximately 30 minutes
- when the ignition is switched on
- if the battery voltage drops
- when the auxiliary heating is switched on

Auxiliary heating

Important safety notes

DANGER

If the exhaust pipe is blocked or sufficient ventilation is not possible, toxic exhaust fumes can enter the vehicle, especially carbon monoxide. This is the case, e.g. in enclosed spaces, or if the vehicle is stuck in snow. There is a risk of fatal injuries.

You should switch off the auxiliary heating in enclosed spaces which do not have an extraction system, e.g. a garage. If the vehicle is stuck in snow and you must leave the auxiliary heating running, keep the exhaust pipe and the area around the vehicle clear of snow. To guarantee a sufficient supply of fresh air, open a window on the side of the vehicle away from the wind.

WARNING

When the auxiliary heating is switched on, parts of the vehicle can become very hot. Flammable material such as leaves, grass or twigs may ignite if they come into contact with hot parts of the exhaust system for extended periods. There is a risk of fire.

When the auxiliary heating is switched on, make sure that no flammable material can come into contact with hot vehicle components.

- ❗ Operating the auxiliary heating/ventilation draws on the vehicle battery. After you have heated or ventilated the vehicle a maximum of two times, drive for a longer distance.

- i Switch the auxiliary heating on regularly once a month for about ten minutes.

The auxiliary heating heats the air in the vehicle interior to the set temperature. This occurs without using the heat of the running engine. The auxiliary heating is operated directly using the vehicle's fuel. For this reason, the tank content must be at least at reserve fuel level to ensure that the auxiliary heating functions.

The auxiliary heating/ventilation automatically adjusts to changes in temperature and weather conditions. For this reason, the auxiliary heating could switch from ventilation mode to heating mode or from heating mode to ventilation mode.

The auxiliary heating switches off automatically after 50 minutes. This time limit can be altered. To do this, visit a qualified specialist workshop.

You cannot use the auxiliary ventilation to cool the vehicle interior to a temperature lower than the outside temperature.

Before switching on

- ▶ Turn the key to position **2** in the ignition lock (▷ page 177).
- ▶ Set the desired temperature.

Auxiliary heating or ventilation can also be switched on if the manually set climate control is activated. Optimum comfort can be attained when the system is set to automatic mode. Set the temperature to 22 °C.

The auxiliary heating/ventilation can be activated or deactivated using the remote control or the button on the centre console.

The on-board computer can be used to specify up to three departure times, one of which may be preselected (▷ page 284).

Switching the auxiliary heating/ventilation on/off using the centre console button

The colours of the indicator lamps on the button have the following meanings:

- Blue Auxiliary ventilation switched on
- Red Auxiliary heating switched on
- Yellow Departure time preselected
(▷ page 284)

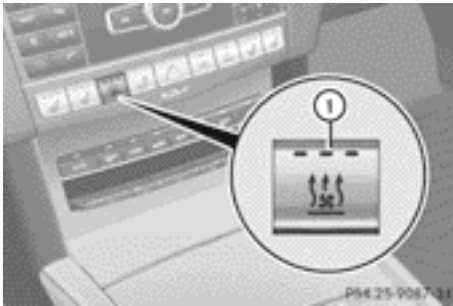

Switch in the centre console

► To switch auxiliary heating/ventilation on: press button ①.

The red or blue indicator lamp in button ① lights up.

► To switch auxiliary heating/ventilation off: press button ①.

The red or blue indicator lamp in button ① goes out.

Switching the auxiliary heating/ventilation on/off using the remote control

General notes

Your vehicle comes with one remote control. You may use two additional remote controls for your vehicle. For more information, please contact a qualified specialist workshop.

The remote control has a maximum range of approximately 300 metres. This range is reduced by:

- sources of radio interference
- solid objects between the remote control and the vehicle

- the remote control being in an unfavourable position in relation to the vehicle
- transmitting from an enclosed space

① The optimum range can be achieved if you hold the remote control vertically, pointing upwards when you press one of the buttons.

① A battery symbol appears in the display when the battery in the remote control is low. Replace the remote control battery (▷ page 170).

Switching the auxiliary heating/ventilation on/off



Remote control

- ① Display
- ② To check the status/set the departure time
- ③ To switch off the auxiliary heating/ventilation
- ④ To switch on the auxiliary heating/ventilation
- ⑤ To check the status/set the departure time

- **To activate:** press the button.
ON is shown in the remote control display.
- **To deactivate:** press the button.
OFF is shown in the remote control display.





Checking the status of the auxiliary heating/ventilation

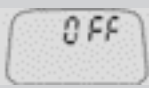
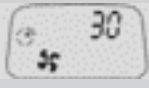
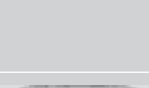
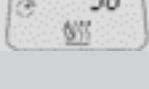
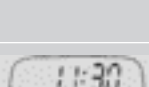
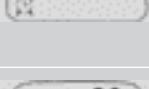





- Press the or button.

The following messages may appear in the display:





Display	Meaning
	The auxiliary heating/ventilation is switched off.
	The auxiliary ventilation is switched on. The number in the display shows the remaining time (in minutes) for the auxiliary ventilation.
	The auxiliary heating is switched on. The number in the display shows the remaining time (in minutes) for the auxiliary heating.
	A departure time has been activated. The departure time appears in the display.
	A departure time has been activated. The auxiliary ventilation is currently activated. The departure time appears in the display.
	A departure time has been activated. The auxiliary heating is currently activated. The departure time appears in the display.

Setting the departure time





- ▶ Press the  or  button repeatedly until the time to be changed appears in the display.
- ▶ Press the  and  buttons simultaneously. The  symbol in the remote control display flashes.

- ▶ Press the  or  button to set the desired departure time.
- ▶  The longer you press the  or  button, the faster the time changes.
- ▶ Press the  and  buttons simultaneously. The new departure time is stored.

Activating the set departure time

- ▶ Press the  or  button repeatedly until the desired departure time appears in the display.
- ▶ Press the  button. The  symbol and the departure time appear in the display.

Deactivating a set departure time

- ▶ Press the  or  button. The status of the auxiliary heating is shown in the display.
- ▶ Press the  button. The first departure time stored appears in the display.
- ▶ Press the  button. **OFF** is shown in the remote control display.

Replacing the remote control battery

WARNING

Batteries contain toxic and corrosive substances. If batteries are swallowed, it can result in severe health problems. There is a risk of fatal injury.

Keep batteries out of the reach of children. If a battery is swallowed, seek medical attention immediately.

Environmental note



Batteries contain pollutants. It is illegal to dispose of them with the household rubbish. They must be collected separately and disposed of in an



environmentally responsible recycling system.

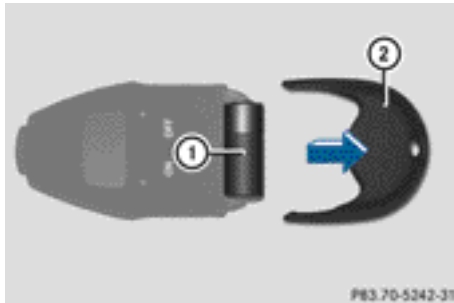

Dispose of batteries in an environmentally responsible manner. Take discharged batteries to a qualified specialist workshop or to a collection point for used batteries.



One 6 V pin battery, type 2CR11108 is required.

- ▶ Prise apart the side arms of battery cover ② and pull off battery cover ②.
- ▶ Remove old battery ①.
- ▶ Insert the new battery. Observe the polarity signs on the back of the remote control when doing so.
- ▶ Slide battery cover ② back onto the remote control.
- ▶ Use the remote control to check the vehicle's auxiliary heating functions.

Problems with the auxiliary heating/ventilation

Display messages	Possible causes/consequences and ► Solutions
FAIL	<p>The starter battery is not charged sufficiently or the system is faulty.</p> <ul style="list-style-type: none"> ► Charge the starter battery. ► Make another attempt to switch on the auxiliary heating using the remote control. ► Have the auxiliary heating checked at a qualified specialist workshop.
 FAIL	<p>The signal transmission between the transmitter and the vehicle is faulty.</p> <ul style="list-style-type: none"> ► Change your position in relation to the vehicle, moving closer if necessary. ► Make another attempt to switch the auxiliary heating on or off using the remote control.
 FAIL	<p>There is not enough fuel in the fuel tank, i.e. the fuel tank is not filled to the reserve fuel level.</p> <ul style="list-style-type: none"> ► Refuel at the nearest filling station. ► Make another attempt to switch on the auxiliary heating using the remote control.
	<p>The auxiliary heating is faulty.</p> <ul style="list-style-type: none"> ► Have the auxiliary heating checked at a qualified specialist workshop.

Adjusting the air vents

Important safety notes

 **WARNING**

Very hot or very cold air can flow from the air vents. This could result in burns or frostbite in the immediate vicinity of the air vents. There is a risk of injury.

Make sure that all vehicle occupants always maintain a sufficient distance to the air outlets. If necessary, redirect the airflow to another area of the vehicle interior.

In order to ensure the direct flow of fresh air through the air vents into the vehicle interior, please observe the following notes:

- keep the air inlet between the windscreen and the bonnet free of blockages, such as ice, snow or leaves.
- never cover the vents or ventilation grilles in the vehicle interior.

Setting the centre air vents

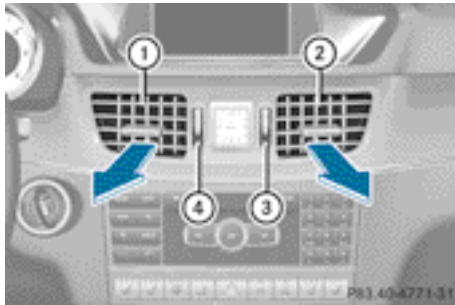

- ① Centre air vent, left
- ② Centre air vent, right
- ③ Centre vent thumbwheel, right
- ④ Centre vent thumbwheel, left

► **To open/close:** turn thumbwheels ③ and ④ up or down.

Adjusting the side air vents

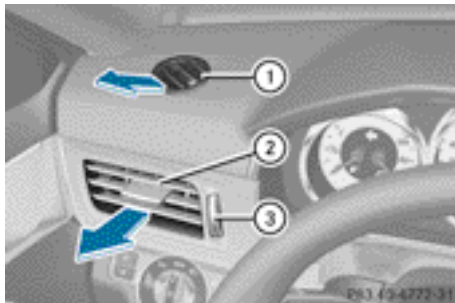

- ① Demister vent
- ② Side air vent
- ③ Control for side air vent

► **To open/close:** turn thumbwheel ③ up or down.

Adjusting the glove compartment air vent

! Close the air vent when heating the vehicle.

At high outside temperatures, open the air vent and activate the "cooling with air dehumidification" function. Otherwise, temperature-sensitive items stored in the glove compartment could be damaged.

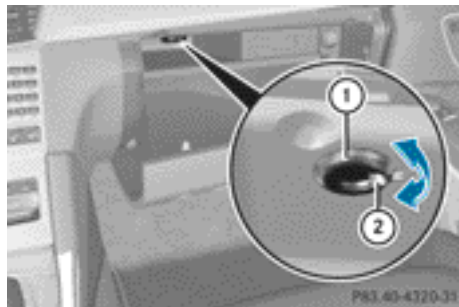

- ① Air vent thumbwheel
- ② Air vent

When automatic climate control is activated, the glove compartment can be ventilated, for instance to cool its contents. The level of airflow depends on the airflow and air distribution settings.

► **To open/close:** turn thumbwheel ① clockwise or anti-clockwise.

Setting the rear-compartment air vents

Setting the centre vents in the rear compartment

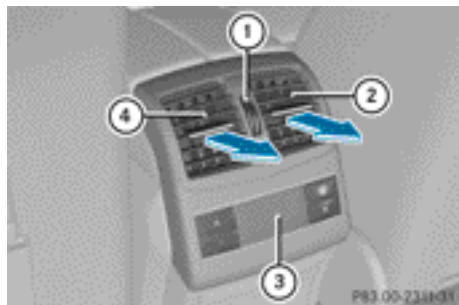

- ① Rear-compartment air vent thumbwheel
- ② Rear-compartment air vent, right

- ③ Rear control panel, only with THERMOTRONIC automatic climate control
 - ④ Rear-compartment air vent, left
- **To open/close:** turn thumbwheel ① up or down.

Setting the rear-compartment side air vents

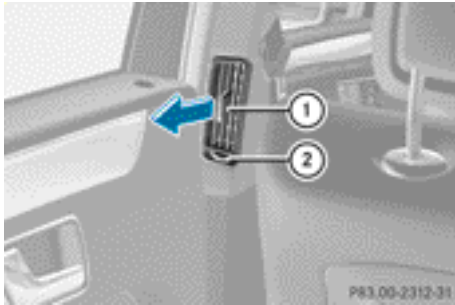

- ① Rear-compartment side air vent
 - ② Thumbwheel for rear-compartment side air vent
- **To open/close:** turn thumbwheel ② to the left or right.

Useful information	176
Running-in notes	176
Driving	176
Manual transmission	185
Automatic transmission	186
Refuelling	195
Parking	199
Driving tips	201
Driving systems	205
Towing a trailer	259

Useful information

- i** This Owner's Manual describes all models, series and optional equipment for your vehicle that were available at the time of going to press. National variations are possible. Note that your vehicle may not be equipped with all of the functions described. This is also the case for systems and functions relevant to safety.
- i** Read the information on qualified specialist workshops: (▷ page 26).

Running-in notes

Important safety notes

New brake pads/linings and discs that have been replaced only achieve optimum braking effect after several hundred kilometres of driving. Compensate for the reduced braking effect by applying greater force to the brake pedal.

The first 1500 km

If you treat the engine with sufficient care from the very start, you will be rewarded with excellent performance for the remainder of the engine's life.

- Drive at varying vehicle speeds and engine speeds for the first 1500 km.
- Avoid overstraining the vehicle during this period, e.g. driving at full throttle.
- Change gear in good time, before the rev counter needle is $\frac{2}{3}$ of the way to the red area of the rev counter.
- Do not shift down a gear manually in order to brake.
- **Vehicles with automatic transmission:** try to avoid depressing the accelerator pedal beyond the point of resistance (kick-down).

After 1500 km, you may gradually accelerate the vehicle to full road and engine speeds.

Additional running-in notes for AMG vehicles:

- Do not drive at speeds above 140 km/h for the first 1500 km.
- Only allow the engine to reach a maximum engine speed of 4500 rpm briefly.
- i** You should also observe these notes on running-in if the engine or parts of the drivetrain on your vehicle have been replaced.

AMG vehicles with self-locking rear axle differential

Your vehicle is equipped with a self-locking differential on the rear axle. Change the oil after a running-in period of 3000 km to improve protection of the rear axle differential. This oil change prolongs the service life of the differential. Have the oil change carried out at a qualified specialist workshop.

Driving

Important safety notes

WARNING

Objects in the driver's footwell may restrict the clearance around the pedals or block a depressed pedal. This jeopardises the operating and road safety of the vehicle. There is a risk of an accident.

Stow all objects securely in the vehicle so that they do not get into the driver's footwell. Always fit the floor mats securely and as prescribed in order to ensure that there is always sufficient room for the pedals. Do not use loose floor mats and do not place several floor mats on top of one another.

WARNING

Unsuitable footwear can hinder correct usage of the pedals, e.g.:

- shoes with thick soles
- shoes with high heels
- slippers

There is a risk of an accident.

Wear suitable footwear to ensure correct usage of the pedals.

WARNING

If you switch off the ignition while driving, safety-relevant functions are only available with limitations, or not at all. This could affect, for example, the power steering and the brake boosting effect. You will require considerably more effort to steer and brake. There is a risk of an accident.

Do not switch off the ignition while driving.

WARNING

If the parking brake has not been fully released when driving, the parking brake can:

- overheat and cause a fire
- lose its hold function.

There is a risk of fire and an accident. Release the parking brake fully before driving off.

! Warm up the engine quickly. Do not use the engine's full performance until it has reached operating temperature.

Only set the automatic transmission to the respective drive positions when the vehicle is stationary.

Where possible, avoid spinning the drive wheels when pulling away on slippery roads. Otherwise, you could damage the drive train.

! **AMG vehicles:** at low engine oil temperatures (below +20 °C), the maximum engine speed is restricted in order to protect the engine. To protect the engine and maintain smooth engine operation, avoid driving at full throttle when the engine is cold.

HYBRID vehicles: make sure that you read the "HYBRID" supplement included in the vehicle literature. Otherwise, you may not recognise dangers.

Key positions

Key

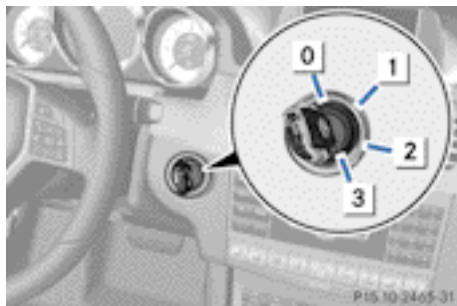

- 0** To remove the key
- 1** Power supply for some consumers, such as the windscreen wipers
- 2** Ignition (power supply for all consumers) and drive position
- 3** To start the engine

i If the key does not belong to the vehicle, it can still be turned in the ignition lock. However, the ignition will not be switched on. The engine cannot be started.

KEYLESS-GO

General notes

- Do not keep the KEYLESS-GO key together with:
 - electronic devices, e.g. a mobile phone or another key
 - metallic objects, e.g. coins or metal film.
- Do not keep the KEYLESS-GO key together with metallic objects, such as a metal case, for example.

This can affect the functionality of KEYLESS-GO.

Vehicles with KEYLESS-GO are equipped with keys featuring an integrated KEYLESS-GO function and a detachable Start/Stop button. The Start/Stop button must be inserted in the ignition lock and the key must be in the vehicle.

Pressing the Start/Stop button several times in succession corresponds to the different key positions in the ignition lock. This is only the case if you are not depressing the brake pedal.

If you depress the brake pedal and press the Start/Stop button, the engine starts immediately.

Key positions with KEYLESS-GO



Switching on the power supply

- ▶ Position 0: if Start/Stop button ① has not yet been pressed, this corresponds to the key being removed from the ignition.
- ▶ Position 1: press Start/Stop button ①. The power supply is switched on. You can now activate the windscreen wipers, for example.

Switching on the ignition

- ▶ Position 2 (ignition): press Start/Stop button ① twice. The ignition is switched on.
- ❗ The ignition is switched off if:
 - the driver's door is opened and
 - you press Start/Stop button ① once when in this position.

Removing the Start/Stop button



- ▶ Remove Start/Stop button ① from ignition lock ②.

❗ When you insert Start/Stop button ① into ignition lock ②, the system needs approximately two seconds' recognition time. You can then use Start/Stop button ①.

You can remove the Start/Stop button from the ignition lock and start the vehicle as normal using the key.

❗ You do not have to remove the Start/Stop button from the ignition lock when you leave the vehicle.

Starting the engine

Important safety notes

⚠ WARNING

If children are left unsupervised in the vehicle, they could:

- open the doors, thus endangering other people or road users.
- get out and disrupt traffic.
- operate the vehicle's equipment.

Additionally, children could set the vehicle in motion if, for example, they:

- release the parking brake.
- shift the automatic transmission out of parking position P.

- shift the manual transmission into neutral.
- start the engine.

There is a risk of an accident and injury.

When leaving the vehicle, always take the key with you and lock the vehicle. Never leave children or animals unattended in the vehicle. Always keep the key out of reach of children.

WARNING

Combustion engines emit poisonous exhaust gases such as carbon monoxide. Inhaling these exhaust gases leads to poisoning. There is a risk of fatal injury. Therefore never leave the engine running in enclosed spaces without sufficient ventilation.

WARNING

Flammable materials introduced through environmental influence or by animals can ignite if in contact with the exhaust system or parts of the engine that heat up. There is a risk of fire.

Carry out regular checks to make sure that there are no flammable foreign materials in the engine compartment or in the exhaust system.

-  Do not depress the accelerator pedal when starting the engine.

General notes

-  **Vehicles with a petrol engine:** the catalytic converter is preheated for up to 30 seconds after a cold start. The sound of the engine may change during this time.





Manual transmission

- ▶ Depress the brake pedal and keep it depressed.
- ▶ Fully depress the clutch pedal.
- ▶ Shift to neutral **N**.
-  You can only start the engine when the clutch pedal is fully depressed.

Automatic transmission

- ▶ Shift the transmission to position **P**.
The transmission position display in the multifunction display shows **P**.
-  You can also start the engine when the transmission is in position **N**.

Starting procedure with the key

-  To start the engine using the key instead of KEYLESS-GO, pull the Start/Stop button out of the ignition lock.
- ▶ **To start a petrol engine:** turn the key to position **3** in the ignition lock (▷ page 177) and release it as soon as the engine is running.
- ▶ **To start a diesel engine:** turn the key to position **2** (▷ page 177) in the ignition lock. The  preglow indicator lamp in the instrument cluster lights up.
- ▶ When the  preglow indicator lamp goes out, turn the key to position **3** (▷ page 177) and release it as soon as the engine is running.
-  You can start the engine without preglow if the engine is warm.

Using KEYLESS-GO to start the engine

-  The Start/Stop button can be used to start the vehicle manually without inserting the key into the ignition lock. The key must be in the vehicle and the Start/Stop button must be inserted in the ignition lock. This mode for starting the engine operates independently of the ECO start/stop automatic engine start function.
- ▶ Depress the brake pedal and keep it depressed.
- ▶ **To start petrol engine:** press the Start/Stop button once (▷ page 177).
The engine starts.
- ▶ **To start a diesel engine:** press the Start/Stop button once (▷ page 177).
Preglow is activated and the engine starts.

Pulling away

Manual transmission

! Change gear in good time and avoid spinning the wheels. Otherwise, you could damage the vehicle.

- ▶ Depress the brake pedal and keep it depressed.
- ▶ Fully depress the clutch pedal.
- ▶ Shift to either first gear or reverse gear **R**.
- ▶ Release the parking brake (▷ page 200).
- ▶ Release the brake pedal.
- ▶ Slowly release the clutch pedal and gently depress the accelerator pedal.

i Follow the shift recommendations in the multifunction display for an economical driving style (▷ page 186).

i The vehicle locks centrally once you have pulled away. The locking knobs in the doors drop down.

You can open the doors from the inside at any time.

You can also deactivate the automatic locking feature (▷ page 284).

Automatic transmission

WARNING

If the engine speed is above the idling speed and you engage transmission position **D** or **R**, the vehicle could pull away suddenly. There is a risk of an accident.

When engaging transmission position **D** or **R**, always firmly depress the brake pedal and do not simultaneously accelerate.

- ▶ Depress the brake pedal and keep it depressed.
- ▶ Shift the transmission to position **D** or **R**.
- ▶ Release the parking brake (▷ page 200).
- ▶ Release the brake pedal.
- ▶ Carefully depress the accelerator pedal.

i It is only possible to shift the transmission from position **P** to the desired position if you depress the brake pedal. Only then is the parking lock released. If the brake pedal is not depressed, the DIRECT SELECT lever can still be moved but the parking lock remains engaged.

i The vehicle locks centrally once you have pulled away. The locking knobs in the doors drop down.

You can open the doors from the inside at any time.

You can also deactivate the automatic locking feature (▷ page 284).

i Upshifts take place at higher engine speeds after a cold start. This helps the catalytic converter to reach its operating temperature more quickly.

Hill start assist

Hill start assist helps you when pulling away forwards or in reverse on an uphill gradient. It holds the vehicle for a short time after you have removed your foot from the brake pedal. This gives you enough time to move your foot from the brake pedal to the accelerator pedal and depress it before the vehicle begins to roll.

WARNING

After a short time, hill start assist will no longer brake your vehicle and it could roll away. There is a risk of an accident and injury.

Therefore, quickly move your foot from the brake pedal to the accelerator pedal. Never leave the vehicle when it is held by hill start assist.

- ▶ Take your foot off the brake pedal. The vehicle is then held for about a second.
- ▶ Pull away.

Hill start assist is not active if:

- you are pulling away on a level road or a downhill gradient.
- on vehicles with automatic transmission, the transmission is in position **N**.
- the parking brake is engaged.
- ESP® is malfunctioning.

ECO start/stop function

Introduction

The ECO start/stop function switches the engine off automatically if the vehicle is stopped under certain conditions.

When pulling away again, the engine starts automatically. The ECO start/stop function thereby helps you to reduce the fuel consumption and emissions of your vehicle.

Important safety notes

WARNING

If the engine is switched off automatically and you exit the vehicle, the engine is restarted automatically. The vehicle may begin moving. There is a risk of accident and injury.

If you wish to exit the vehicle, always turn off the ignition and secure the vehicle against rolling away.

General notes

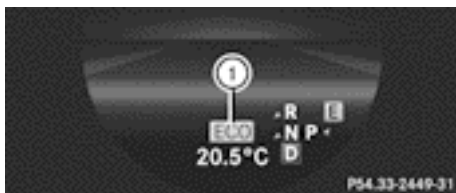

① ECO start/stop display

i Hybrid vehicles: observe the notes on the ECO start/stop function in the "HYBRID" supplement.

If the **ECO** symbol is shown in green in the multifunction display, the ECO start/stop

function switches the engine off automatically if the vehicle stops moving.

Every time you switch on the engine using the key or the Start/Stop button, the ECO start/stop function is activated.

If the ECO start/stop function has been manually deactivated (▷ page 183) or a malfunction has caused the system to be deactivated, the **ECO** symbol is not displayed.

AMG vehicles: the **Stop/Start active** or **Stop/Start inactive** message in the AMG menu in the multifunction display goes out.

AMG vehicles: the ECO start/stop function is only available in drive program **C**.

For further information on automatic engine switch-off (▷ page 181) and automatic engine start (▷ page 182).

Automatic engine switch-off

General notes

The ECO start/stop function is operational and the **ECO** symbol is displayed in green in the multifunction display, if:

- the indicator lamp in the ECO button is lit green
- the outside temperature is within the comfort range
- the engine is at normal operating temperature
- the set temperature for the vehicle interior has been reached
- the battery is sufficiently charged
- the system detects that the windscreen is not misted up when the air-conditioning system is switched on
- the bonnet is closed
- the driver's door is closed and the driver's seat belt is fastened.

If not all conditions for automatic engine switch-off are fulfilled, the **ECO** symbol is shown in yellow.

AMG vehicles: the AMG menu in the multifunction display additionally shows the **Stop/Start inactive** message.

i All of the vehicle's systems remain active when the engine is switched off automatically.

i **All vehicles (except AMG vehicles):** automatic engine switch-off can take place a maximum of four times consecutively (initial stop, then three subsequent stops). The **[ECO]** symbol is shown in yellow in the multifunction display after the engine has been started automatically for the fourth time. When the **[ECO]** symbol is shown in green in the multifunction display, automatic engine switch-off is again possible.

i **AMG vehicles:** the number of consecutive automatic engine stops is unlimited.

Vehicles with manual transmission



The ECO start/stop function switches off the engine automatically at low speeds.

- ▶ Brake the vehicle.
- ▶ Engage neutral **N** (follow gearshift instruction ① to engage neutral **N**, if necessary).
- ▶ Release the clutch pedal.
The engine is switched off automatically.

Vehicles with automatic transmission

If the vehicle is braked to a standstill in **D** or **N**, the ECO start/stop function switches off the engine automatically.

i The HOLD function can be activated if the engine has been switched off automatically. It is then not necessary to continue applying the brakes during the automatic stop phase. When you depress the accelerator pedal, the engine starts automati-

cally and the braking effect of the HOLD function is deactivated.

Automatic engine start

General notes

The engine is started automatically if:

- you switch off the ECO start/stop function by pressing the ECO button
- you engage reverse gear **R**
- you switch to drive program **S**, **S+** or **M** (AMG vehicles)
- the vehicle starts to roll
- the brake system requires this
- the temperature in the vehicle interior deviates from the set range
- the system detects moisture on the windshield when the air-conditioning system is switched on
- the battery's charge status is too low
- the driver's seat belt is released or the driver's door is opened.

Vehicles with manual transmission

i Only engage gear when the clutch pedal is depressed.

The engine is started automatically if you:

- depress the clutch pedal fully
- depress the accelerator pedal.

Vehicles with automatic transmission

The engine is started automatically if you:

- release the brake pedal when HOLD is not activated and the transmission is in position **D** or **N**
- depress the accelerator pedal
- move the transmission out of position **P**.

i Shifting the transmission to position **P** does not start the engine.

i If you shift the transmission from **R** to **D**, the ECO start/stop function is available again once the **[ECO]** symbol reappears in green in the multifunction display.

Deactivating/activating the ECO start/stop function

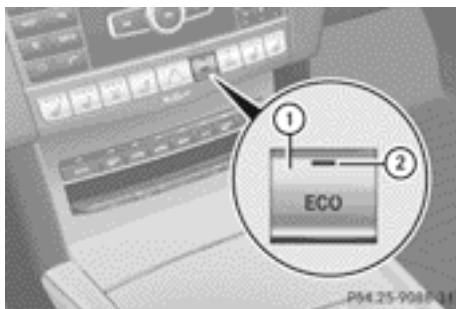

ECO button

- ▶ **To switch off (except AMG vehicles):** press button ①.
Indicator lamp ② and the **ECO** symbol in the multifunction display go out.
- ▶ **To switch on (except AMG vehicles):** press button ①.
Indicator lamp ② lights up. If all conditions for automatic engine switch-off (▷ page 181) are fulfilled, the **ECO** symbol is shown in green in the multifunction display.
If not all conditions for automatic engine switch-off (▷ page 181) are fulfilled, the **ECO** symbol is shown in yellow in the multifunction display. If this is the case, the ECO start/stop function is not available.
- ▶ **To switch off (AMG vehicles):** in program **C**, press button ①.

or

- ▶ Switch to drive program **S**, **S+** or **M** (▷ page 190).
Indicator lamp ② and the **ECO** symbol in the multifunction display go out.
The **Stop/Start active** or **Stop/Start inactive** message in the AMG menu in the multifunction display goes out.
- ▶ **To switch on (AMG vehicles):** press button ①.
Indicator lamp ② lights up. If drive program **S**, **S+** or **M** is active, the automatic transmission switches to drive program **C**.

If all conditions for automatic engine switch-off (▷ page 181) are fulfilled, the **ECO** symbol is shown in green in the multifunction display. In addition, the **Stop/Start active** message is shown in the AMG menu in the multifunction display.

If not all conditions for automatic engine switch-off (▷ page 181) are fulfilled, the **ECO** symbol is shown in yellow. If this is the case, the ECO start/stop function is not available. In addition, the **Stop/Start inactive** display message is shown in the AMG menu in the multifunction display.

- ❗ If indicator lamp ② is off, the ECO start/stop function has been deactivated manually or as the result of a malfunction. The engine will then not be switched off automatically when the vehicle stops.

Problems with the engine	
Problem	Possible causes/consequences and ► Solutions
The engine does not start.	<p>The HOLD function or DISTRONIC PLUS is activated.</p> <ul style="list-style-type: none"> ► Deactivate the HOLD function (▷ page 221) or DISTRONIC PLUS (▷ page 218). ► Try to start the engine again.
The engine does not start. The starter motor can be heard.	<ul style="list-style-type: none"> • There is a malfunction in the engine electronics. • There is a malfunction in the fuel supply. <p>► Before attempting to start the engine again, turn the key in the ignition back to position 0 or press the Start/Stop button repeatedly until all indicator lamps in the instrument cluster go out.</p> <p>► Try to start the engine again (▷ page 178). Avoid excessively long and frequent attempts to start the engine, as this will drain the battery.</p> <p>If the engine does not start after several attempts:</p> <ul style="list-style-type: none"> ► Consult a qualified specialist workshop.
The engine does not start. The starter motor can be heard. The reserve fuel warning lamp is lit and the fuel gauge display shows 0 .	<p>The fuel tank is empty.</p> <ul style="list-style-type: none"> ► Refuel the vehicle.
The engine does not start. You cannot hear the starter motor.	<p>The on-board voltage is too low because the battery is too weak or discharged.</p> <ul style="list-style-type: none"> ► Jump-start the vehicle (▷ page 393). <p>If the engine does not start despite attempts to jump-start it:</p> <ul style="list-style-type: none"> ► Consult a qualified specialist workshop. <p>The starter motor was exposed to a thermal load that was too high.</p> <ul style="list-style-type: none"> ► Allow the starter motor to cool down for approximately two minutes. ► Try to start the engine again. <p>If the engine still does not start:</p> <ul style="list-style-type: none"> ► Consult a qualified specialist workshop.

Problem	Possible causes/consequences and ► Solutions
Vehicles with a petrol engine: The engine is not running smoothly and is misfiring.	There is a malfunction in the engine electronics or in a mechanical component of the engine management system. <ul style="list-style-type: none"> ► Only depress the accelerator pedal slightly. Otherwise, non-combusted fuel may get into the catalytic converter and damage it. ► Have the cause rectified immediately at a qualified specialist workshop.
The coolant temperature display is showing more than 120 °C. The coolant warning lamp may also be lit and a warning tone may sound.	The coolant level is too low. The coolant is too hot and the engine is no longer being cooled sufficiently. <ul style="list-style-type: none"> ► Stop as soon as possible and allow the engine and the coolant to cool down. ► Check the coolant level (► page 368). Observe the warning notes as you do so and top up the coolant if necessary. <p>If the coolant level is correct, the engine radiator fan may be faulty. The coolant is too hot and the engine is no longer being cooled sufficiently.</p> <ul style="list-style-type: none"> ► If the coolant temperature is below 120 °C, you can continue driving to the nearest qualified specialist workshop. ► Avoid heavy loads on the engine as you do so, e.g. driving in mountainous terrain and stop-start traffic.

Manual transmission

Gear lever

- ❗ Only engage gear when the clutch pedal is depressed.
- ❗ When shifting between **5th** and **6th** gear, you should always push the gear lever all the way to the right. Otherwise, you could shift unintentionally into **3rd** or **4th** gear and damage the transmission.

If you shift down at too high a speed (transmission braking), this can cause the engine to overrev, leading to engine damage.

Do not use the clutch bite point to keep the vehicle stationary on uphill gradients. There is otherwise a risk of damaging the clutch.
- ❗ On long and steep downhill gradients, especially if the vehicle is laden or towing

a trailer, you must shift into gear **1**, **2** or **3** in good time. This uses the engine's braking effect. This relieves the load on the brake system and prevents the brakes from overheating and wearing too quickly.

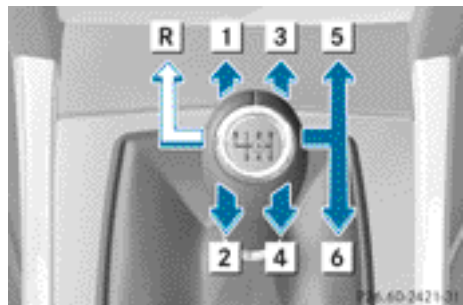

Gear lever

- R** Reverse gear
- 1** to **6** Forward gears

Shifting to neutral (N)

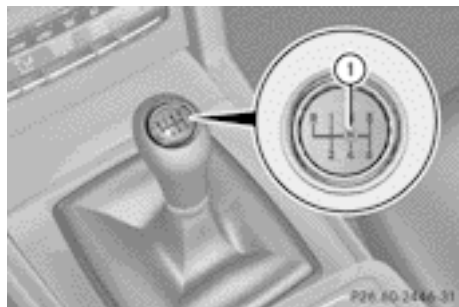

- ▶ Depress the clutch pedal fully.
- ▶ Move the gear lever to position **N** ①.

Engaging reverse gear

- ❗ Only shift into reverse gear **R** when the vehicle is stationary. Otherwise, you could damage the transmission.
- ▶ Move the gear lever firmly to the left beyond the point of resistance and then forwards.
- ❗ The ECO start/stop function is not available when reverse gear is engaged. For further information on the ECO start/stop function; see (▶ page 181).

Gearshift recommendation



- ▶ Shift gear according to gearshift recommendation ① when shown in the multifunction display of the instrument cluster.

The gearshift recommendations assist you in adopting an economical driving style. The recommended gear is shown in the multifunction display.

Automatic transmission

Important safety notes

⚠ WARNING

If the engine speed is above the idling speed and you engage transmission position **D** or **R**, the vehicle could pull away suddenly. There is a risk of an accident.

When engaging transmission position **D** or **R**, always firmly depress the brake pedal and do not simultaneously accelerate.

⚠ WARNING

The automatic transmission switches to neutral position **N** when you switch off the engine. The vehicle may roll away. There is a risk of an accident.

After switching off the engine, always switch to parking position **P**. Prevent the parked vehicle from rolling away by applying the parking brake.

HYBRID vehicles: ensure that you read the "HYBRID" supplement included in the vehicle literature. Otherwise, you may not recognise dangers.

Selector lever

Overview of transmission positions

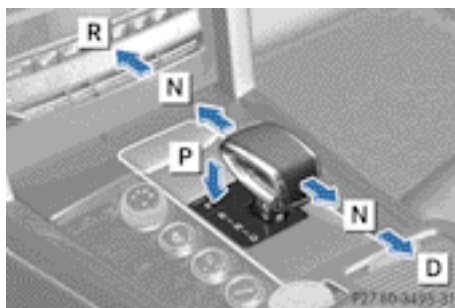

Selector lever in AMG vehicles with P button

- P** Park position with parking lock
- R** Reverse gear

- N** Neutral
- D** Drive

Transmission position and drive program display

! If the transmission position display in the multifunction display is not working, you should pull away carefully to check whether the desired transmission position is engaged. For this purpose, we recommend selecting transmission position **D** and automatic drive program **E** (drive program **C** in AMG vehicles) or **S**.



Example: transmission position display and drive program display

- ① Transmission position display
- ② Drive program display

The current transmission position and drive program appear in the multifunction display.

DIRECT SELECT lever

Overview of transmission positions

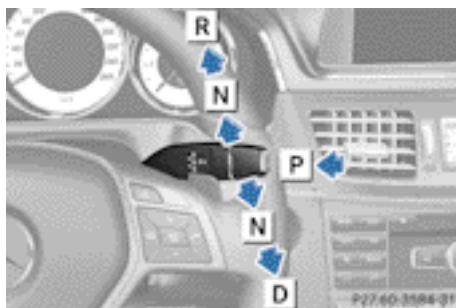

- P** Park position with parking lock
- R** Reverse gear

- N** Neutral
- D** Drive

The DIRECT SELECT lever is on the right of the steering column.

i The DIRECT SELECT lever always returns to its original position. The current transmission position **P**, **R**, **N** or **D** appears in the transmission position display (▷ page 187) in the multifunction display.

Transmission position and drive program display

! If the transmission position display in the multifunction display is not working, you should pull away carefully to check whether the desired transmission position is engaged. Ideally, you should select transmission position **D** and drive program **E** or **S**.



- ① Transmission position display
- ② Drive program display

The current transmission position and drive program appear in the multifunction display.

i The arrows in the transmission position display show how and into which transmission positions you can change using the DIRECT SELECT lever.

Engaging park position P

! If the engine speed is too high, do not shift the automatic transmission directly from **D** to **R**, from **R** to **D** or directly to **P**. Otherwise, the automatic transmission could be damaged.

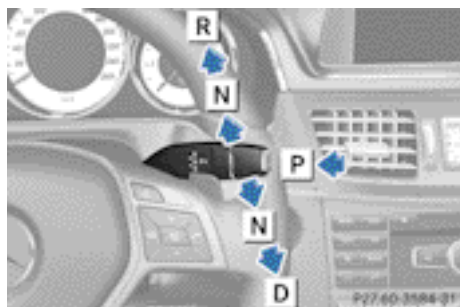

- P** Park position with parking lock
- R** Reverse gear
- N** Neutral
- D** Drive

► Push the DIRECT SELECT lever in the direction of arrow **P**.

i The automatic transmission shifts into park position **P** automatically:

- if you open the driver's door while the vehicle is stationary in transmission position **D** or **R**
- if you open the door while travelling at very low speeds in transmission position **D** or **R**.

i Depressing the brake and pushing the DIRECT SELECT lever up or down disengages the parking lock. The transmission is in **N** neutral.

In order to shift from park position **P** directly into **R** or **D**:

- depress the brake pedal and
- push the DIRECT SELECT lever up or down past the first point of resistance.

Engaging reverse gear R

! Only shift the automatic transmission to **R** when the vehicle is stationary.

► Push the DIRECT SELECT lever up past the first point of resistance.

i The ECO start/stop function is not available when reverse gear is engaged.

For further information on the ECO start/stop function; see (▷ page 181).

Shifting to neutral (N)

! WARNING

If children are left unsupervised in the vehicle, they can:

- open doors and endanger other persons or road users
- climb out and be injured by the traffic
- operate vehicle equipment and, for example, trap themselves.

Children could also set the vehicle in motion, for example by:

- releasing the parking brake
- shifting the automatic transmission out of park position **P**
- starting the engine.

There is a risk of an accident and injury.

When leaving the vehicle, always take the key with you and lock the vehicle. Never leave children unattended in the vehicle. Always keep the key out of reach of children.

► Push the DIRECT SELECT lever up or down to the first point of resistance.

Engaging drive position D

► Push the DIRECT SELECT lever down past the first point of resistance.

Transmission positions

P

Park position

This prevents the vehicle from rolling away when stopped. Do not shift the transmission into position **P** (> page 199) unless the vehicle is stationary.

The automatic transmission shifts to **P** automatically if you:

- remove the key
- switch off the engine when in **R** or **D** and open one of the front doors

R

Reverse gear

Only shift the transmission to **R** when the vehicle is stationary.

N

Neutral

Do not shift the transmission to **N** while driving. Otherwise, the automatic transmission could be damaged.

Releasing the brakes will allow you to move the vehicle freely, e.g. to push it or tow it.

If ESP® is deactivated or faulty: only shift the transmission to position **N** if the vehicle is in danger of skidding, e.g. on icy roads.

If you switch off the engine using the key or the Start/Stop button, the automatic transmission shifts to neutral **N** automatically.

! Rolling in neutral **N** can lead to damage to the transmission.

D

Drive

The automatic transmission changes gear automatically. All forward gears are available.

Changing gear

The automatic transmission shifts to the individual gears automatically when it is in transmission position **D**. Gearshifting is determined by:

- the selected drive program (> page 190)
- the position of the accelerator pedal
- the road speed

Driving tips

Accelerator pedal position

Your style of driving influences how the automatic transmission shifts gear:

- little throttle: early upshifts
- more throttle: late upshifts

AMG vehicles

When shifting down, the double-clutch function is active regardless of the currently selected drive program. The double-clutch function reduces load change reactions and is conducive to a sporty driving style. The sound generated by the double-clutch function depends on the drive program selected.

Kickdown

Use kickdown for maximum acceleration.

- ▶ Depress the accelerator pedal beyond the pressure point.
The transmission shifts to a lower gear depending on the engine speed.
- ▶ Ease off the accelerator pedal once the desired speed is reached.
The automatic transmission shifts back up.

Towing a trailer

- ▶ Drive in the middle of the engine speed range on uphill gradients.
- ▶ Shift down to gear **3** or **2** (> page 191) depending on the uphill or downhill gradi-

ent, even if cruise control, DISTRONIC PLUS or SPEEDTRONIC is activated.

Program selector button

General notes



All vehicles (except AMG vehicles and vehicles with Sports package AMG)

- ▶ Press program selector button ① repeatedly until the letter for the desired gearshift program appears in the multifunction display.

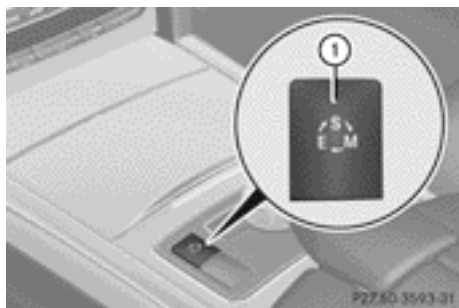

Vehicles with the AMG Sports package

- ▶ Press program selector button ① repeatedly until the letter for the desired drive program appears in the multifunction display.

The program selector button allows you to choose between different driving characteristics.

- ① Further information about permanent drive program **M**(▷ page 193).

As well as this permanent drive program **M**, you can also activate temporary drive program **M**(▷ page 191).

E Economy	Comfortable, economical driving
S Sport	Sporty driving style
M Manual	Manual gearshifting

- ① For further information on the automatic drive program, see (▷ page 191).
- ① The automatic transmission switches to automatic drive program **E** each time the engine is started.

AMG vehicles

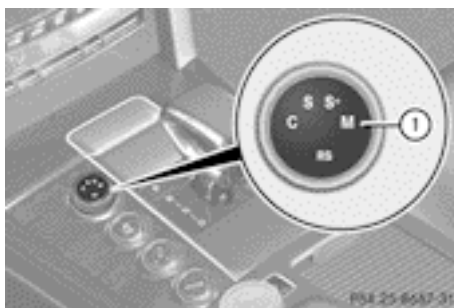

Drive program selector with manual drive program

- ▶ Turn drive program selector ① until the desired drive program appears in the multifunction display in the speedometer. The drive program indicator on drive program selector ① lights up in red.

- ① Further information about permanent drive program **M**(▷ page 193).

As well as this permanent drive program **M**, you can also activate temporary drive program **M**(▷ page 191).

C Controlled Efficiency	Comfortable, economical driving
S Sport	Sporty driving style

S+ SportPlus	Extremely sporty driving style
M Manual	Manual gearshifting
RS RACE START	Optimal vehicle acceleration from a standstill

- i** For further information on the automatic drive program, see (▷ page 191).
- i** The automatic transmission switches to automatic drive program **C** each time the engine is started.
- i** **RS** cannot be selected during normal driving. For further information on **RACE START**; see (▷ page 223).

Steering wheel gearshift paddles

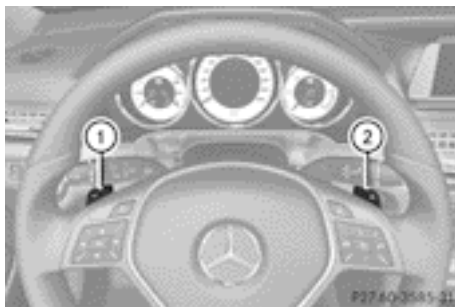

In the manual drive program, you can change gears manually using steering wheel gearshift paddles ① and ②.

Further information about permanent drive program **M** (▷ page 193).

Further information about temporary drive program **M** (▷ page 191).

- i** You can only change gear with the steering wheel gearshift paddles when the transmission is in position **D**.

Automatic drive program

Automatic drive programs **E** and **S**

Drive program **E** (drive program **C** on AMG vehicles) is characterised by the following:

- comfort-oriented engine settings.
- optimal fuel consumption resulting from the automatic transmission shifting up sooner.
- the vehicle pulling away more gently in forward and reverse gears unless the accelerator pedal is depressed fully.
- increased sensitivity. This improves driving stability on slippery road surfaces, for example.
- the automatic transmission shifting up sooner. This results in the vehicle being driven at lower engine speeds and the wheels being less likely to spin.

Drive program **S** (or, in the case of AMG vehicles, drive programs **S** and **S+**) is characterised by the following:

- sporty engine and automatic transmission settings.
- the vehicle pulling away in first gear.
- the automatic transmission shifting up later.
- as a result of the later automatic transmission shift points, the fuel consumption possibly being higher.

Manual drive program **M**

General notes

In this drive program, you can briefly change gear yourself by using the steering wheel gearshift paddles. The transmission must be in position **D**.

You can activate manual drive program **M** in the **E** and **S** automatic drive programs.

- i** As well as temporary drive program **M**, you can also activate permanent drive program **M** (▷ page 190).

Further information about permanent drive program **M** (▷ page 193).

Activating

- ▶ Shift the transmission to position **D**.
- ▶ Pull the left or right steering wheel gearshift paddle (▷ page 191).
Manual drive program **M** is temporarily activated. The selected gear and **M** appear in the multifunction display.

Shifting gears

If you pull on the left or right steering wheel gearshift paddle, the automatic transmission switches to manual drive program **M** for a limited amount of time. Depending on which gearshift paddle is pulled, the automatic transmission immediately shifts into the next gear down or up, if permitted.

- ▶ **To shift up:** pull the right-hand steering wheel gearshift paddle (▷ page 191).
The automatic transmission shifts up to the next gear.
- i** If the maximum engine speed on the currently engaged gear is reached and you continue to accelerate, the automatic transmission automatically shifts up in order to prevent engine damage.
- ▶ **To shift down:** pull on the left-hand steering wheel gearshift paddle (▷ page 191).
The automatic transmission shifts down to the next gear.
- i** If the engine exceeds the maximum engine speed when shifting down, the automatic transmission protects against engine damage by not shifting down.
- i** Automatic downshifting occurs when coasting.

Gearshift recommendation



The gearshift recommendations assist you in adopting an economical driving style. The recommended gear is shown in the multifunction display.

- ▶ Shift to recommended gear ② according to gearshift recommendation ① when shown in the multifunction display of the instrument cluster.

Deactivating

If you have activated manual drive program **M**, it will remain active for a certain amount of time. Under certain conditions the minimum amount of time is extended, e.g. in the case of lateral acceleration, during an overrun phase or when driving on steep terrain.

If manual drive program **M** has been deactivated, the automatic transmission shifts into the automatic drive program that was last selected, i.e. **E** or **S**.

You can also deactivate manual drive program **M** yourself:

- ▶ Pull on the right-hand steering wheel gearshift paddle and hold it in place (▷ page 191).
- or
- ▶ Use the DIRECT SELECT lever to switch the transmission position.
- or
- ▶ Use the program selector button to change the drive program (▷ page 190).
Manual drive program **M** is deactivated. The automatic transmission switches into the automatic drive program that was last selected, i.e. **E** or **S**.

Manual drive program (AMG vehicles and vehicles with the AMG Sports package)

General notes

In this drive program, you can permanently change gear yourself by using the steering wheel gearshift paddles. The transmission must be in position **D**.

- i** As well as this permanent drive program **M**, you can also activate temporary drive program **M** (▷ page 191).

Activating the manual drive program

- ▶ Press the (▷ page 190) program selector button repeatedly until **M** appears in the multifunction display.
- ▶ **AMG vehicles:** turn the drive program selector (▷ page 190) until **M** appears in the multifunction display.
The indicator **M** on the drive program selector lights up in red.

Manual drive program **M** can be selected using the program selector button or the drive program selector. In manual drive program **M**, you can change gear using the steering wheel gearshift paddles if the transmission is in position **D**.

Upshifting (all vehicles except AMG vehicles)

- ▶ Pull the right-hand steering wheel gearshift paddle.
The automatic transmission shifts up to the next gear.

Upshifting (AMG vehicles)

- !** In manual gearshift program **M**, the automatic transmission does not shift up automatically even when the engine limiting speed for the current gear is reached. When the engine limiting speed is reached, the fuel supply is cut to prevent the engine from overrevving. You must make sure that

the engine speed does not reach the red area of the rev counter. Otherwise, there is a risk of engine damage.



- ① Gear indicator
- ② Upshift indicator
- ▶ If the colour in the speedometer multifunction display changes to red and the **UP** display message is shown, shift up a gear.

Gearshift recommendation



The gearshift recommendations assist you in adopting an economical driving style. The recommended gear is shown in the multifunction display.

- ▶ If relevant gearshift recommendation ① appears in the multifunction display on the instrument cluster, pull on the right-hand steering wheel gearshift paddle (▷ page 191).
The automatic transmission shifts to recommended gear ②.

Downshifting

- ▶ Pull the left-hand steering wheel gearshift paddle.
The automatic transmission shifts down to the next gear.
- i** For maximum acceleration, pull the left-hand steering wheel gearshift paddle until

the transmission selects the optimum gear for the current speed.

Kickdown

You can also use kickdown for maximum acceleration in manual drive program **M**.

- ▶ Depress the accelerator pedal beyond the pressure point.
The transmission shifts to a lower gear depending on the engine speed.

i **AMG vehicles:** it is not possible to use kickdown in manual drive program **M**.

Deactivating the manual drive program

- ▶ Press the program selector button (▷ page 190) repeatedly until **E** or **S** appears in the multifunction display.
- ▶ **AMG vehicles:** turn the drive program selector (▷ page 190) until **C**, **S** or **S+** appears in the multifunction display.

Problems with the transmission

Problem	Possible causes/consequences and ► Solutions
The transmission has problems shifting gear.	The transmission is losing oil. ► Have the transmission checked at a qualified specialist workshop immediately.
The acceleration ability is deteriorating. The transmission no longer changes gear.	The transmission is in emergency mode. It is only possible to shift into second gear and reverse gear. ► Stop. ► Shift the transmission to position P . ► Switch off the engine. ► Wait at least ten seconds before restarting the engine. ► Shift the transmission to position D or R . If D is selected, the transmission shifts into second gear; if R is selected, the transmission shifts into reverse gear. ► Have the transmission checked at a qualified specialist workshop immediately.

Refuelling

Important safety notes

WARNING

Fuel is highly flammable. If you handle fuel incorrectly, there is a risk of fire and explosion.

You must avoid fire, naked flames, creating sparks and smoking. Switch off the engine and, if applicable, the auxiliary heating before refuelling.

WARNING

Fuels are poisonous and hazardous to health. There is a danger of injury.

Do not swallow fuel or let it come into contact with skin, eyes or clothing. Do not inhale fuel vapours. Keep fuels out of the reach of children.

If you or others come into contact with fuel, observe the following:

- Wash the fuel off any affected areas of skin with water and soap immediately.
- If you get fuel in your eyes, rinse them thoroughly with clean water immediately. Seek immediate medical attention.
- If fuel is swallowed, seek immediate medical attention. Do not induce vomiting.
- Change any clothing that has come into contact with fuel immediately.

WARNING

Electrostatic charge can cause sparks and thereby ignite fuel vapours. There is a risk of fire and explosion.

Always touch the vehicle body before opening the fuel filler flap or touching the fuel pump nozzle. This discharges any electrostatic charge that may have built up.

WARNING

Vehicles with a diesel engine:

If you mix diesel fuel with petrol, the flash point of this fuel mixture is lower than that of pure diesel fuel. When the engine is running, components in the exhaust system may overheat unnoticed. There is a risk of fire.

Never refuel with petrol. Never add petrol to diesel fuel.

! Do not use petrol to refuel vehicles with a diesel engine. Do not use diesel to refuel vehicles with a petrol engine. Do not switch on the ignition if you accidentally refuel with the wrong fuel. Otherwise, the fuel will enter the fuel system. Even small amounts of the wrong fuel could result in damage to the fuel system and the engine. The repair costs are high. Notify a qualified specialist workshop and have the fuel tank and fuel lines drained completely.

! Overfilling the fuel tank could damage the fuel system.

! Take care not to spill any fuel on painted surfaces. You could otherwise damage the paintwork.

! Use a filter when adding fuel from a fuel can. The fuel lines and/or the diesel injection system could otherwise be blocked by particles from the fuel can.

Do not get into the vehicle again during the refuelling process. Otherwise, electrostatic charge could build up again.

If you overfill the fuel tank, some fuel may spray out when you remove the fuel pump nozzle.

For further information on fuel and fuel quality (▷ page 469).

Refuelling

Opening/closing the fuel filler flap

Pay attention to the important safety notes (▷ page 195).

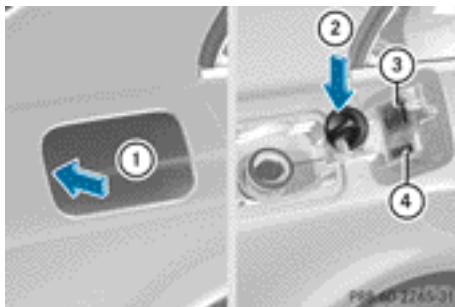

- ① Opening the fuel filler flap
- ② To insert the fuel filler cap
- ③ Tyre pressure table
- ④ Fuel type to be refuelled

The fuel filler flap is unlocked or locked automatically when you open or close the vehicle with the key or using KEYLESS-GO.

The position of the  fuel filler cap is displayed in the instrument cluster. The arrow next to the filling pump indicates the side of the vehicle.

Opening the fuel filler flap

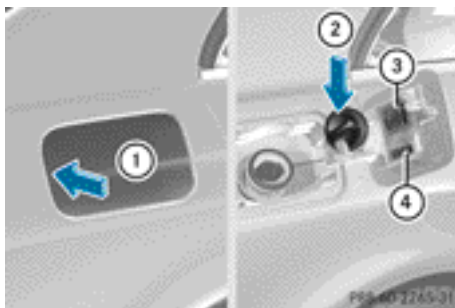

- ① To open the fuel filler flap
- ② To insert the fuel filler cap
- ③ Tyre pressure table
- ④ Fuel type to be refuelled

- ▶ Switch off the engine.
- ▶ Remove the key from the ignition lock.
- ▶ KEYLESS-GO: open the driver's door. This corresponds to key position **0**: "key removed".

The driver's door can be closed again.

- ▶ Press the fuel filler flap in the direction of arrow ①.
The fuel filler flap opens slightly.
- ▶ Open the fuel filler flap fully.
- ▶ Turn the fuel filler cap anti-clockwise and remove it.
- ▶ **Saloon:** insert the fuel filler cap into the bracket on the inside of fuel filler flap ②.

or

- ▶ **Estate:** insert the fuel filler cap into the recesses in the fuel filler flap hinge arm horizontally from above.
- ▶ Completely insert the filler neck of the fuel pump nozzle into the tank, hook in place and refuel.
- ▶ Only fill the tank until the pump nozzle switches off.
- ❗ Do not add any more fuel after the pump stops filling for the first time. Otherwise, fuel may leak out.

Closing the fuel filler flap

- ▶ Replace the cap on the filler neck and turn clockwise until it engages audibly.
- ▶ Press the fuel filler flap closed until it engages audibly.
- ❗ Close the fuel filler flap before locking the vehicle. Otherwise, the locking pin of the central locking prevents the fuel filler flap from closing.

Fuel filler flap emergency release

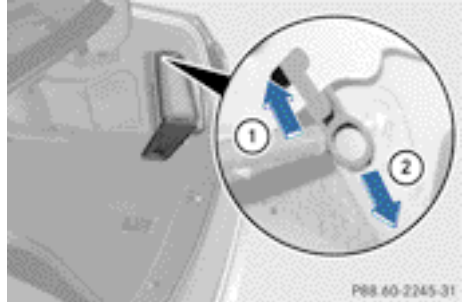

- ▶ **Saloon:** open the boot lid.
- ▶ Slide the luggage net down.
- ▶ Open the right-hand side trim panel.
- ▶ Remove the first-aid kit (▷ page 382).
- ▶ Detach the emergency release from retainer ①.
- ▶ Pull the emergency release in the direction of arrow ②.
The fuel filler flap is released.
- ▶ Open the fuel filler flap.

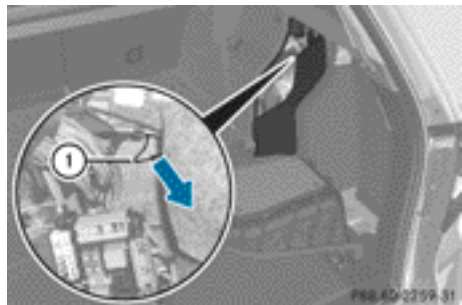

- ▶ **Estate:** open the tailgate.
- ▶ Open the right-hand side trim panel.
- ▶ Fold down the trim.
- ▶ Pull emergency release ① in the direction of the arrow.
The fuel filler flap is released.
- ▶ Open the fuel filler flap.

Problems with the fuel and fuel tank	
Problem	Possible causes/consequences and ► Solutions
Fuel is leaking from the vehicle.	<p>The fuel line or the fuel tank is faulty.</p> <p> WARNING</p> <p>There is a risk of fire or explosion.</p> <ul style="list-style-type: none"> ► Turn the key to position 0 in the ignition lock immediately and remove it (▷ page 177). ► Do not restart the engine under any circumstances. ► Consult a qualified specialist workshop.
The engine does not start.	<p>The fuel tank of a vehicle with a diesel engine has been run completely dry.</p> <ul style="list-style-type: none"> ► Refuel the vehicle with at least 5 litres of diesel. ► Turn the ignition on for approximately ten seconds (▷ page 177). ► Start the engine continuously for a maximum of ten seconds until it runs smoothly. <p>If the engine does not start:</p> <ul style="list-style-type: none"> ► Turn the ignition on again a maximum of ten seconds (▷ page 177). ► Start the engine again continuously for a maximum of ten seconds until it runs smoothly. <p>If the engine does not start after three attempts:</p> <ul style="list-style-type: none"> ► Consult a qualified specialist workshop.
The fuel filler flap cannot be opened.	<p>The fuel filler flap is not unlocked.</p> <p>or</p> <p>The key battery is discharged.</p> <ul style="list-style-type: none"> ► Unlock the vehicle using the emergency key element (▷ page 90). ► Open the boot lid or the tailgate. ► Manually unlock the fuel filler flap using the emergency release (▷ page 197). <p>The fuel filler flap is unlocked, but the opening mechanism is jammed.</p> <ul style="list-style-type: none"> ► Consult a qualified specialist workshop.

Parking

Important safety notes

⚠ WARNING
 Flammable material such as leaves, grass or twigs may ignite if they come into contact with hot parts of the exhaust system or exhaust gas flow. There is a risk of fire.
 Park the vehicle so that no flammable material can come into contact with hot vehicle components. In particular, do not park on dry grassland or harvested grain fields.

⚠ WARNING
 If you switch off the ignition while driving, safety-relevant functions are only available with limitations, or not at all. This could affect, for example, the power steering and the brake boosting effect. You will require considerably more effort to steer and brake. There is a risk of an accident.
 Do not switch off the ignition while driving.

⚠ WARNING
 If you leave children unattended in the vehicle, they could set the vehicle in motion by, for example:

- releasing the parking brake
- shifting an automatic transmission out of parking position **P**
- shifting a manual transmission into neutral
- starting the engine

They could also operate vehicle equipment. There is a risk of an accident and injury.
 When leaving the vehicle, always take the key with you and lock the vehicle. Never leave children unattended in the vehicle.

! Always secure the vehicle correctly against rolling away. Otherwise, the vehicle or its drivetrain could be damaged.

To ensure that the vehicle is secured against rolling away unintentionally:

- the parking brake must be applied
- on vehicles with manual transmission, engage first gear or reverse gear
- on vehicles with automatic transmission, the transmission must be in position **P** and the key must be removed from the ignition lock
- on uphill or downhill gradients, the front wheels must be turned towards the kerb.

Switching off the engine

Important safety notes

⚠ WARNING
 The automatic transmission switches to neutral position **N** when you switch off the engine. The vehicle may roll away. There is a risk of an accident.
 After switching off the engine, always switch to parking position **P**. Prevent the parked vehicle from rolling away by applying the parking brake.

Vehicles with manual transmission

- ▶ Shift to either first gear or reverse gear **R**.
- ▶ Turn the key to position **0** in the ignition lock and remove it.
 The immobiliser is activated.
- ▶ Firmly depress the parking brake.

Vehicles with automatic transmission

- ▶ **All vehicles (except AMG vehicles):** shift the transmission to position **P**.

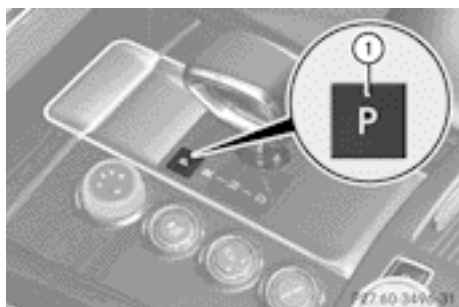

Selector lever in AMG vehicles with P button

► **AMG vehicles:** press **P** button ①.

Using the key

► Turn the key to position **0** in the ignition lock and remove it.

The immobiliser is activated.

► Firmly depress the parking brake.

i **All vehicles (except AMG vehicles):** you can only remove the key if the transmission is in position **P**.

i If you switch the engine off with the transmission in position **R** or **D**, the automatic transmission shifts to **N** automatically.

If you then open one of the front doors or remove the key from the ignition, the automatic transmission shifts to **P**.

If you shift the automatic transmission to **N** before switching off the engine, the automatic transmission remains in **N** even if a door is opened.

Using KEYLESS-GO

► Press the Start/Stop button (▷ page 177). The engine stops and all the indicator lamps in the instrument cluster go out.

► Firmly depress the parking brake.

i If you use the Start/Stop button to switch off the engine, the automatic transmission shifts to **N** automatically. If you then open one of the front doors, the automatic transmission shifts to **P**.

i The engine can be switched off while the vehicle is in motion by pressing and holding the Start/Stop button for about three sec-

onds. This function operates independently of the ECO start/stop automatic engine switch-off function.

Parking brake

⚠ WARNING

If you must brake the vehicle with the parking brake, the braking distance is considerably longer and the wheels could lock. This increases the risk of skidding and an accident.

Only use the parking brake to brake the vehicle when the service brake is faulty. Do not apply the parking brake too firmly. If the wheels lock, release the parking brake until the wheels begin turning again.

⚠ WARNING

If you leave children unattended in the vehicle, they could set the vehicle in motion by, for example:



- releasing the parking brake
- shifting an automatic transmission out of parking position **P**
- shifting a manual transmission into neutral
- starting the engine

They could also operate vehicle equipment. There is a risk of an accident and injury.

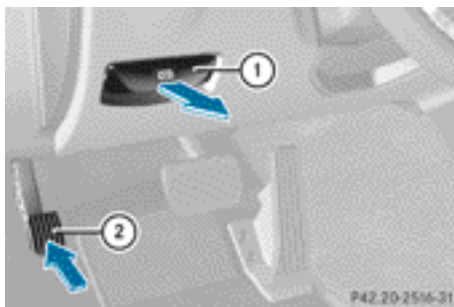
When leaving the vehicle, always take the key with you and lock the vehicle. Never leave children unattended in the vehicle.



The brake lights do not light up when you brake the vehicle with the parking brake.

- ▶ **To apply:** depress parking brake ② firmly. The  indicator lamp in the instrument cluster lights up if the engine is running.
- ▶ **To release:** depress the brake pedal and keep it depressed.
- ▶ Pull release handle ①. The  indicator lamp in the instrument cluster goes out.

Parking up the vehicle

If you leave the vehicle parked up for longer than four weeks, the battery may be damaged by exhaustive discharging.

If you leave the vehicle parked up for longer than six weeks, the vehicle may suffer damage as a result of lack of use.

- ▶ Visit a qualified specialist workshop and seek advice.
-  You can obtain information about trickle chargers from a qualified specialist workshop.

Driving tips

General notes

WARNING

If you switch off the ignition while driving, safety-relevant functions are only available with limitations, or not at all. This could affect, for example, the power steering and the brake boosting effect. You will require considerably more effort to steer and brake. There is a risk of an accident.

Do not switch off the ignition while driving.

ECO display



Example: ECO display

The ECO display provides feedback on how economical your driving characteristics are. The ECO display assists you in achieving the most economical driving style for the selected settings and prevailing conditions. Consumption can be significantly influenced by your driving style.

The ECO display consists of three bars:

- Acceleration
- Constant
- Coasting

The percentage count is the mean value of the three bar values. The three bars and the mean value begin at the value of 50%. A higher percentage count indicates a more economical driving style.

The ECO display does not indicate the actual fuel consumption and a fixed percentage count in the ECO display does not indicate a fixed consumption figure.

In addition to driving style, the consumption is affected by many other factors, such as:

- load
- tyre pressure
- cold start
- choice of route
- the use of electrical consumers

These factors are not included in the ECO display.

The evaluation of your driving style takes the following three categories into consideration:

- **Acceleration** (evaluation of all acceleration processes):
 - The bar fills up: moderate acceleration, especially at higher speeds
 - The bar empties: sporty acceleration
- **Constant** (assessment of driving behaviour at all times):
 - The bar fills up: constant speed and avoidance of unnecessary acceleration and deceleration
 - The bar empties: fluctuations in speed
- **Coasting** (assessment of all deceleration processes):
 - The bar fills up: anticipatory driving, keeping your distance and early release of the accelerator. The vehicle can coast without use of the brakes.
 - The bar empties: frequent braking

i An economical driving style involves driving at a moderate engine speed.

To achieve a higher value in the categories **Acceleration** and **Constant**:

- observe the gearshift recommendation.
- drive the vehicle in drive program **E** (vehicles with automatic transmission).

i On long journeys at a constant speed, e.g. on the motorway, only the bar for **Constant** will change.

i The ECO display summarises the driving characteristics from the start of the journey to its completion. Therefore, there are dynamic changes in the bars at the start of a journey. During a prolonged driving time, these changes are smaller. For more dynamic changes, perform a manual reset.

For further information on the ECO display, see (▷ page 272).

Braking

Important safety notes

WARNING

If you shift down on a slippery road surface in an attempt to increase the engine's braking effect, the drive wheels could lose their grip. This increases the risk of skidding and having an accident.

Do not shift down for additional engine braking on a slippery road surface.

Downhill gradients

Do not depress the brake pedal continuously while the vehicle is in motion, e.g. never cause the brakes to rub by constantly applying light pressure to the pedal. This results in excessive and premature wear to the brake pads.

Change into a lower gear in good time on long and steep downhill gradients.

Take particular note of this when driving a laden vehicle and when towing a trailer.

i This also applies if you have activated cruise control, SPEEDTRONIC or DIS-TRONIC PLUS.

This will use the braking effect of the engine, so less braking will be required to maintain vehicle speed. This relieves the load on the brake system and prevents the brakes from overheating and wearing too quickly.

Heavy and light loads

WARNING

The braking system can overheat if you leave your foot on the brake pedal while driving. This increases the braking distance and could even cause the braking system to fail. There is a risk of an accident.

Never use the brake pedal as a footrest. Do not simultaneously depress both the brake pedal and the accelerator pedal while driving.

! Depressing the brake pedal constantly results in excessive and premature wear to the brake pads.

If the brakes have been subjected to a heavy load, do not stop the vehicle immediately, but drive on for a short while. This allows the airflow to cool the brakes more quickly.

If the brakes have been used only moderately, you should occasionally test their effectiveness. To do this, brake more firmly from a higher speed. This improves the grip of the brakes.

Wet road surfaces

If you have driven for a long time in heavy rain without braking, there may be a delayed reaction from the brakes when braking for the first time. This may also occur after the vehicle has been washed or driven through deep water. You have to depress the brake pedal more firmly. Maintain a greater distance from the vehicle in front.

After driving on a wet road or having the vehicle washed, brake firmly while paying attention to the traffic conditions. This will warm up the brake discs, thereby drying them more quickly and protecting them against corrosion.

Limited braking performance on salt-treated roads

If you drive on salted roads, a layer of salt residue may form on the brake discs and brake pads. This can result in a significantly longer braking distance.

- Brake occasionally to remove any possible salt residue. Make sure that you do not endanger other road users when doing so.
- Carefully depress the brake pedal at the beginning and end of a journey.
- Maintain a greater distance to the vehicle ahead.

New brake pads/linings

New and replaced brake pads and discs only reach their optimum braking effect after several hundred kilometres of driving. Compensate for this by applying greater force to the brake pedal.

For safety reasons, Mercedes-Benz recommends that you only have brake pads/linings fitted to your vehicle which have been approved for Mercedes-Benz vehicles or which correspond to an equivalent quality standard. Brake pads/linings which have not been approved for Mercedes-Benz vehicles or which are not of an equivalent quality could affect your vehicle's operating safety.

AMG high-performance and ceramic brakes

AMG brake systems are designed for heavy loads. This may lead to noise when braking. This is dependent on:

- speed
- braking force
- environmental conditions, such as temperature and humidity

The wear of individual components of the brake system, such as the brake pads/linings or brake discs, depends on the individual driving style and operating conditions.

For this reason, it is impossible to state a mileage (service life) that will be valid under all circumstances. An aggressive driving style will lead to high wear. You can obtain further information about this from your Mercedes-Benz Service Centre.

New brake pads/brake pads and discs that have been replaced only achieve optimum braking effect after several hundred kilometres of driving. Compensate for the reduced braking effect by applying greater force to the brake pedal. Always be aware of this and adapt your driving and braking accordingly during the running-in period.

Excessive heavy braking results in correspondingly high brake wear. Observe the

 brake pad wear warning lamp in the instrument cluster and note any brake status messages in the multifunction display. If you regularly drive at high speeds, it is particularly important to have the brake system checked and maintained regularly.

Driving on wet roads

Aquaplaning

If water has accumulated to a certain depth on the road surface, there is a danger of aquaplaning occurring, even if:

- you are driving at low speeds.
- the tyres have adequate tread depth.

For this reason, do not drive in tyre ruts and brake carefully.

Driving on flooded roads

! Bear in mind that vehicles travelling in front or in the opposite direction create waves. This may cause the maximum permissible water depth to be exceeded.

These notes must be observed under all circumstances. You could otherwise damage the engine, the electronics or the transmission.

If you have to drive on stretches of road on which water has collected, please bear in mind that:

- the maximum permissible still water depth is 25 cm.
- you should drive no faster than at walking pace.

Winter driving

Important safety notes

WARNING

If you shift down on a slippery road surface in an attempt to increase the engine's braking effect, the drive wheels could lose their grip.

This increases the risk of skidding and having an accident.

Do not shift down for additional engine braking on a slippery road surface.

DANGER

If the exhaust pipe is blocked or adequate ventilation is not possible, poisonous gases such as carbon monoxide (CO) may enter the vehicle. This is the case, e.g. if the vehicle becomes trapped in snow. There is a risk of fatal injury.

If you leave the engine or the auxiliary heating running, make sure the exhaust pipe and area around the vehicle are clear of snow. To ensure an adequate supply of fresh air, open a window on the side of the vehicle that is not facing into the wind.

Have your vehicle winterproofed at a qualified specialist workshop at the onset of winter.

Observe the notes in the "Winter operation" section (> page 406).

Driving with summer tyres

Observe the notes in the "Winter operation" section (> page 406).

Slippery road surfaces

WARNING

If you shift down on a slippery road surface in an attempt to increase the engine's braking effect, the drive wheels could lose their grip. This increases the risk of skidding and having an accident.

Do not shift down for additional engine braking on a slippery road surface.

If the vehicle threatens to skid or cannot be stopped when moving at low speed:

- ▶ **Vehicles with manual transmission:** shift to neutral.
- ▶ **Vehicles with automatic transmission:** shift the transmission to position **N**.
- ▶ Try to bring the vehicle under control by using corrective steering.

You should drive particularly carefully on slippery road surfaces. Avoid sudden acceleration, steering and braking manoeuvres.

- ❗ For more information on driving with snow chains; see (▶ page 407).

The outside temperature indicator is not designed to serve as an ice-warning device and is therefore unsuitable for that purpose. Changes in the outside temperature are displayed after a short delay.

Indicated temperatures just above the freezing point do not guarantee that the road surface is free of ice. The road may still be icy, especially in wooded areas or on bridges. The vehicle could skid if you fail to adapt your driving style. Always adapt your driving style and drive at a speed to suit the prevailing weather conditions.

You should pay special attention to road conditions when temperatures are around the freezing point.

Driving systems

Cruise control

General notes

Cruise control maintains a constant road speed for you. It brakes automatically in order to avoid exceeding the set speed. You must select a low gear in good time on long and steep downhill gradients, especially if the vehicle is laden or towing a trailer. By doing so, you will make use of the braking effect of the engine. This relieves the load on the brake system and prevents the brakes from overheating and wearing too quickly.

Use cruise control only if road and traffic conditions make it appropriate to maintain a steady speed for a prolonged period. You can store any road speed above 30 km/h.

Important safety notes

If you fail to adapt your driving style, cruise control can neither reduce the risk of an accident nor override the laws of physics. Cruise control cannot take into account road, weather or traffic conditions. Cruise control is only an aid. You are responsible for the distance to the vehicle in front, for vehicle speed, for braking in good time, and for staying in the lane.

Do not use cruise control:

- in road and traffic conditions which do not allow you to maintain a constant speed (e.g. in heavy traffic or on winding roads)
- on smooth or slippery roads. Braking or accelerating can cause the drive wheels to lose traction and the vehicle could then skid
- when there is poor visibility, e.g. due to fog, heavy rain or snow

If there is a change of drivers, advise the new driver of the speed stored.

Cruise control lever

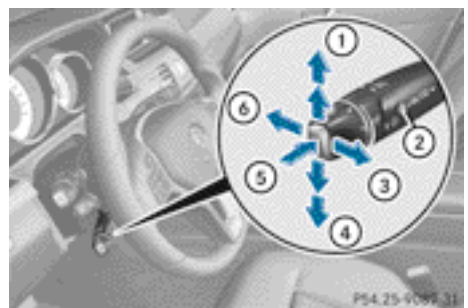

- ① To activate or increase speed
- ② LIM indicator lamp
- ③ To activate at the current speed/last stored speed
- ④ To activate or reduce speed

- ⑤ To switch between cruise control and variable SPEEDTRONIC
- ⑥ To deactivate cruise control

You can operate cruise control and variable SPEEDTRONIC with the cruise control lever. The LIM indicator lamp on the cruise control lever indicates which system you have selected:

- **LIM indicator lamp off:** cruise control is selected.
- **LIM indicator lamp on:** variable SPEEDTRONIC is selected.

When you activate cruise control, the stored speed is shown in the multifunction display for five seconds.

Activation conditions

To activate cruise control, all of the following activation conditions must be fulfilled:

- the parking brake must be released
- you are driving faster than 30 km/h.
- ESP® must be switched on, but not intervening
- the transmission must be in position **D**
- the cruise control function must be selected (▷ page 206)

Selecting cruise control

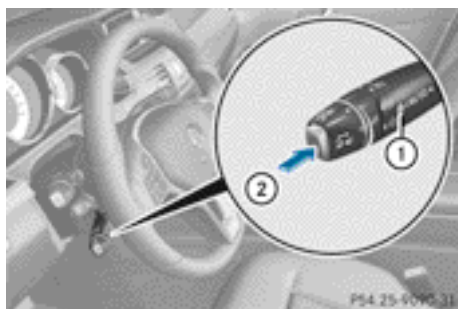

- ▶ Check whether LIM indicator lamp ① is off. If it is off, cruise control is already selected.

If it is not off, press the cruise control lever in the direction of arrow ②.

LIM indicator lamp ① in the cruise control lever goes out. Cruise control is selected.

Storing and maintaining the current speed

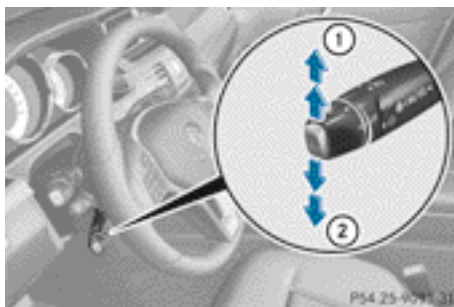

You can accept the current speed if you are driving faster than 30 km/h.

- ▶ Accelerate the vehicle to the desired speed.
- ▶ Briefly press the cruise control lever up ① or down ②.
- ▶ Remove your foot from the accelerator pedal. Cruise control is activated. The vehicle automatically maintains the stored speed.

i Cruise control may be unable to maintain the stored speed on uphill gradients. The stored speed is resumed when the gradient evens out. Cruise control maintains the stored speed on downhill gradients by automatically braking the vehicle.

- i** Vehicles with manual transmission:
 - always drive at adequate, but not excessive, engine speeds
 - Change gear in good time.
 - if possible, do not change down several gears at a time

Storing the current speed and calling up the last stored speed

WARNING

If you call up the stored speed and it is lower than the current speed, the vehicle decelerates. If you do not know the stored speed, the vehicle could decelerate unexpectedly. There is a risk of an accident.

Pay attention to the road and traffic conditions before calling up the stored speed. If you do not know the stored speed, store the desired speed again.

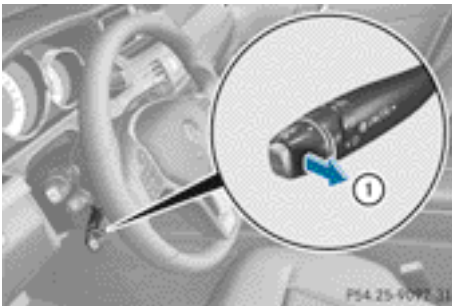

- ▶ Briefly pull the cruise control lever towards you ①.
- ▶ Remove your foot from the accelerator pedal.
The first time cruise control is activated, it stores the current speed or regulates the speed of the vehicle to the previously stored speed.

Setting a speed

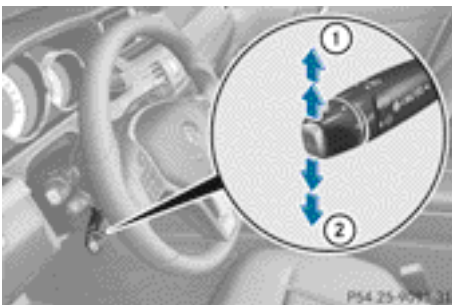

- ▶ Press the cruise control lever up ① for a higher speed or down ② for a lower speed.
- ▶ Keep the cruise control lever pressed until the desired speed is reached.
- ▶ Release the cruise control lever.
The new speed is stored.
- ▶ **To adjust the set speed in 1 km/h increments:** briefly press the cruise control lever up ① or down ② to the pressure point.
The last stored speed increases or decreases in 1 km/h increments.
- ▶ **To adjust the set speed in 10 km/h increments:** press the cruise control lever briefly up ① or down ② beyond the pressure point.
The last stored speed increases or decreases in 10 km/h increments.

i Cruise control is not deactivated if you depress the accelerator pedal. For example, if you accelerate briefly to overtake, cruise control adjusts the vehicle's speed to the last speed stored after you have finished overtaking.

Deactivating cruise control

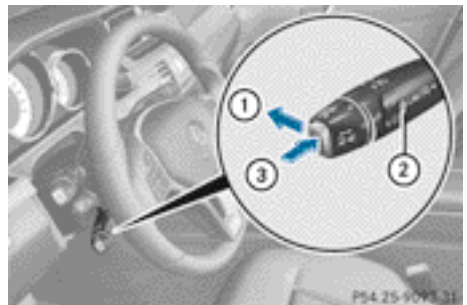

There are several ways to deactivate cruise control:

- ▶ Briefly press the cruise control lever forwards ①.
- or
- ▶ Brake

or

- ▶ Briefly move the cruise control lever in the direction of arrow ③.

Variable SPEEDTRONIC is selected. LIM indicator lamp ② in the cruise control lever is on.

Cruise control is automatically deactivated if:

- you depress the parking brake
- you are driving at less than 30 km/h
- ESP® intervenes or you deactivate ESP®
- you shift into neutral in a vehicle with manual transmission while driving or depress the clutch pedal for longer than six seconds
- on vehicles with manual transmission, you shift to a gear that is too high, and as a result the engine speed is too low
- on vehicles with automatic transmission, you shift into position **N** while driving

If cruise control is deactivated, you will hear a warning tone. You will see the **Cruise control off** message in the multifunction display for approximately five seconds.

- ❗ The last speed stored is cleared when you switch off the engine.

SPEEDTRONIC

Important safety notes

SPEEDTRONIC brakes automatically so that you do not exceed the set speed. Change into a lower gear in good time on long and steep downhill gradients. Take particular note of this when driving a laden vehicle. By doing so, you will make use of the braking effect of the engine. This relieves the load on the brake system and prevents the brakes from overheating and wearing too quickly. If you need additional braking, depress the brake pedal repeatedly rather than continuously.

If you fail to adapt your driving style, SPEEDTRONIC can neither reduce the risk of an accident nor override the laws of physics. SPEEDTRONIC cannot take into account road, weather or traffic conditions. SPEED-

TRONIC is only an aid. You are responsible for the distance to the vehicle in front, for vehicle speed, for braking in good time, and for staying in the lane.

If there is a change of drivers, advise the new driver of the speed stored.

You can set a variable or permanent limit speed:

- **variable** for speed limits, e.g. in built-up areas
- **permanent** for long-term speed restrictions, e.g. when driving with winter tyres fitted

- ❗ The speed indicated in the speedometer may differ slightly from the limit speed stored.

Variable SPEEDTRONIC

General notes

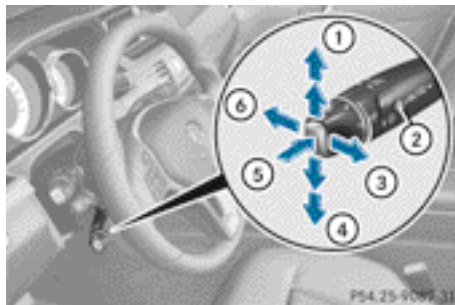

- ① To store the current speed or a higher speed
- ② LIM indicator lamp
- ③ Storing the current speed and calling up the last stored speed
- ④ To store the current speed or a lower speed
- ⑤ To switch between cruise control or DISTRONIC PLUS and variable SPEEDTRONIC
- ⑥ To deactivate variable SPEEDTRONIC

With the cruise control lever, you can operate cruise control or DISTRONIC PLUS and variable SPEEDTRONIC.

The LIM indicator lamp on the cruise control lever indicates which system you have selected:

- **LIM indicator lamp off:** cruise control or DISTRONIC PLUS is selected.
- **LIM indicator lamp on:** variable SPEEDTRONIC is selected.

Selecting variable SPEEDTRONIC



If there is a change of drivers, advise the new driver of the limit speed stored.

- ▶ Check whether LIM indicator lamp ① is on. If it is on, variable SPEEDTRONIC is already selected.

If it is not, press the cruise control lever in the direction of arrow ②.

LIM indicator lamp ① in the cruise control lever is lit. Variable SPEEDTRONIC is selected.

Storing the current speed

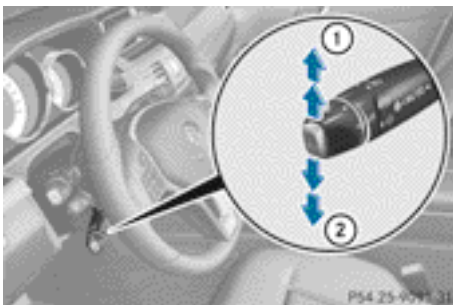

- ▶ Briefly press the cruise control lever up ① or down ②.

The current speed is stored and shown in the multifunction display.

The segments in the multifunction display light up from the start of the scale up to the stored speed.

You can use the cruise control lever to limit the speed to any speed above 30 km/h while the engine is running.

Storing the current speed and calling up the last stored speed

⚠ WARNING

If you call up the stored speed and it is lower than the current speed, the vehicle decelerates. If you do not know the stored speed, the vehicle could decelerate unexpectedly. There is a risk of an accident.

Pay attention to the road and traffic conditions before calling up the stored speed. If you do not know the stored speed, store the desired speed again.

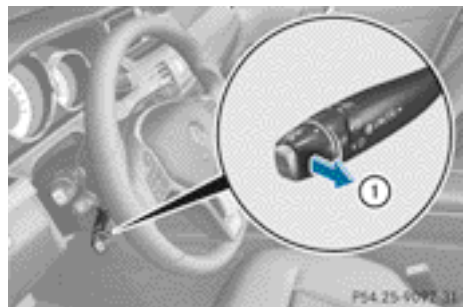

- ▶ Briefly pull the cruise control lever towards you ①.

Setting a speed

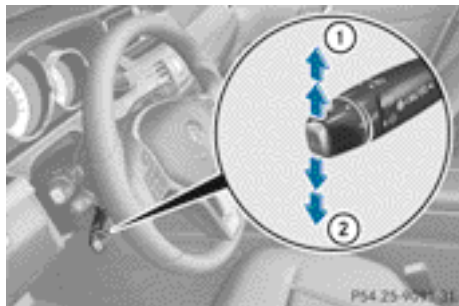

- ▶ **To adjust the set speed in 10 km/h increments:** briefly press the cruise control lever up ① past the pressure point for a higher speed or down ② for a lower speed.

or

- ▶ Keep the cruise control lever pressed beyond the pressure point until the desired speed is set. Press the cruise control lever up ① for a higher speed or down ② for a lower speed.
- ▶ **To adjust the set speed in 1 km/h increments:** briefly press the cruise control lever up ① to the pressure point for a higher speed or down ② for a lower speed.

or

- ▶ Keep the cruise control lever pressed to the pressure point until the desired speed is set. Press the cruise control lever up ① for a higher speed or down ② for a lower speed.

Deactivating variable SPEEDTRONIC

It is not possible to deactivate variable SPEEDTRONIC by braking.

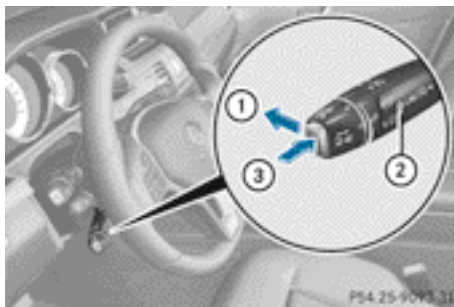

There are several ways to deactivate variable SPEEDTRONIC:

- ▶ Briefly press the cruise control lever forwards ①.
- or
- ▶ Briefly move the cruise control lever in the direction of arrow ③.
LIM indicator lamp ② in the cruise control lever goes out. Variable SPEEDTRONIC is deactivated.
Cruise control or DISTRONIC PLUS is selected.

- ❗ The last speed stored is cleared when you switch off the engine.

Kickdown

If you depress the accelerator pedal beyond the pressure point (kickdown), SPEEDTRONIC is switched to passive. The following message appears in the multifunction display: **SPEEDTRONIC passive**.

You can then exceed the stored speed. SPEEDTRONIC is activated again if you:

- drive slower than the stored speed without kickdown
- set a new speed or
- call up the last speed stored again.

The **SPEEDTRONIC passive** message in the multifunction display disappears.

Permanent SPEEDTRONIC

You can use the on-board computer to limit the speed permanently to a value between 160 km/h (e.g. for driving on winter tyres) and the maximum speed (▷ page 284).

Shortly before the stored speed is reached, it appears in the multifunction display.

Permanent SPEEDTRONIC remains active, even if variable SPEEDTRONIC is deactivated.

You cannot exceed the stored limit speed, even if you depress the accelerator pedal beyond the pressure point (kickdown).

DISTRONIC PLUS

General notes

DISTRONIC PLUS regulates the speed and automatically helps you maintain the distance to the vehicle detected in front. Vehicles are detected with the aid of the radar sensor system. DISTRONIC PLUS brakes automatically so that the set speed is not exceeded.

Change into a lower gear in good time on long and steep downhill gradients. Take particular note of this when driving a laden vehicle. By doing so, you will make use of the braking effect of the engine. This relieves the load on the brake system and prevents the brakes from overheating and wearing too quickly.

If DISTRONIC PLUS detects that there is a risk of a collision, you will be warned visually and acoustically. Without your intervention, DISTRONIC PLUS cannot prevent a collision. An intermittent warning tone will then sound and the distance warning lamp will light up in the instrument cluster. Brake immediately to increase the distance to the vehicle driving in front, or take evasive action, provided it is safe to do so.

For DISTRONIC PLUS to assist you, the radar sensor system must be operational.

DISTRONIC PLUS operates in the range between 0 km/h and 200 km/h.

Do not use DISTRONIC PLUS while driving on roads with steep gradients.

Important safety notes

WARNING

Hybrid vehicles: ensure that you read the "HYBRID" supplement. You could otherwise fail to recognise dangers.

WARNING

DISTRONIC PLUS does not react to:

- people or animals
- stationary obstacles on the road, e.g. stopped or parked vehicles
- oncoming and crossing traffic

As a result, DISTRONIC PLUS may neither give warnings nor intervene in such situations.

There is a risk of an accident.

Always pay careful attention to the traffic situation and be ready to brake.

WARNING

DISTRONIC PLUS cannot always clearly identify other road users and complex traffic situations.

In such cases, DISTRONIC PLUS may:

- give an unnecessary warning and then brake the vehicle
- neither give a warning nor intervene
- accelerate unexpectedly

There is a risk of an accident.

Continue to drive carefully and be ready to brake, in particular when warned to do so by DISTRONIC PLUS.

WARNING

DISTRONIC PLUS brakes your vehicle with up to 50% of the maximum possible deceleration. If this deceleration is not sufficient, DISTRONIC PLUS alerts you with a visual and acoustic warning. There is a risk of an accident.

Apply the brakes yourself in these situations and try to take evasive action.

! If DISTRONIC PLUS or the HOLD function is activated, the vehicle brakes automatically in certain situations. To prevent damage to the vehicle, deactivate DISTRONIC PLUS and the HOLD function in the following or other similar situations:

- when towing the vehicle
- in the car wash

If you fail to adapt your driving style, DISTRONIC PLUS can neither reduce the risk of an accident nor override the laws of physics. DISTRONIC PLUS cannot take road and weather conditions or traffic conditions into account. DISTRONIC PLUS is only an aid. You are responsible for the distance to the vehicle in front, for vehicle speed, for braking in good time, and for staying in the lane.

Do not use DISTRONIC PLUS:

- in road and traffic conditions which do not allow you to maintain a constant speed (e.g. in heavy traffic or on winding roads)
- on smooth or slippery roads. Braking or accelerating can cause the drive wheels to lose traction and the vehicle could then skid
- when there is poor visibility, e.g. due to fog, heavy rain or snow

DISTRONIC PLUS may not detect narrow vehicles driving in front, e.g. motorcycles, or vehicles driving on a different line.

In particular, the detection of obstacles can be impaired in the case of:

- dirt on the sensors or the sensors are obscured
- snow or heavy rain
- interference by other radar sources
- the possibility of strong radar reflections, for example, in multi-storey car parks

If DISTRONIC PLUS no longer detects a vehicle in front, it may unexpectedly accelerate to the speed stored.

This speed can:

- be too high for a filter lane or a slip road
- be so high in the right lane that you pass vehicles driving on the left (left-hand drive countries)
- be so high in the left lane that you pass vehicles driving on the right (right-hand drive countries)

If there is a change of drivers, advise the new driver of the speed stored.

Cruise control lever

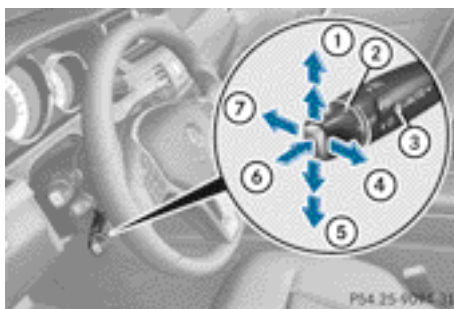

- ① To store the current speed or a higher speed
- ② To set the specified minimum distance
- ③ LIM indicator lamp
- ④ To store the current speed and call up the last stored speed
- ⑤ To store the current speed or a lower speed
- ⑥ To switch between DISTRONIC PLUS and variable SPEEDTRONIC
- ⑦ To deactivate DISTRONIC PLUS

You can operate DISTRONIC PLUS and variable SPEEDTRONIC with the cruise control lever.

The LIM indicator lamp on the cruise control lever indicates which system you have selected:

- **LIM indicator lamp off:** DISTRONIC PLUS is selected.
- **LIM indicator lamp on:** variable SPEEDTRONIC is selected.

Selecting DISTRONIC PLUS



- ▶ Check whether LIM indicator lamp ① is off. If it is off, DISTRONIC PLUS is already selected.
- If it is not off, press the cruise control lever in the direction of arrow ②.
- LIM indicator lamp ① in the cruise control lever goes out. DISTRONIC PLUS is selected.

Activating DISTRONIC PLUS

Activation conditions

To activate DISTRONIC PLUS, the following conditions must be fulfilled:

- the engine must be running. It may take up to two minutes of driving before DISTRONIC PLUS is ready for use.
- the parking brake must be released.
- ESP® must be switched on, but not intervening.
- Active Parking Assist must not be activated.
- the transmission must be in position **D**.
- the driver's door must be closed when you shift from **P** to **D** or your seat belt must be fastened.
- the front-passenger door and the rear doors must be closed.
- the vehicle must not be skidding.
- the DISTRONIC PLUS function must be selected with the cruise control lever (▷ page 213).

Priming

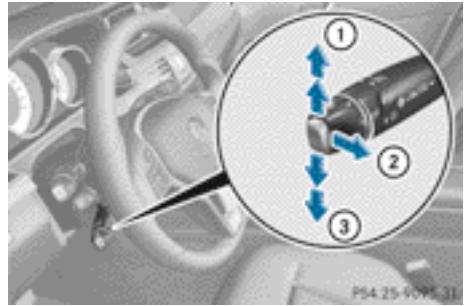

- ▶ Briefly pull the cruise control lever towards you ②, or press it up ① or down ③. DISTRONIC PLUS is activated.
- ▶ Press the cruise control lever repeatedly up ① or down ③ until the desired speed is set.
- ▶ Remove your foot from the accelerator pedal. Your vehicle adapts its speed to that of the vehicle in front, but only up to the desired stored speed.

i If you do not fully release the accelerator pedal, the **DISTRONIC PLUS suspended** message appears in the multifunction display. The set distance to a slower-moving vehicle in front will then not be maintained. You will be driving at the speed you determine by the position of the accelerator pedal.

You can also activate DISTRONIC PLUS when stationary. The lowest speed that can be set is 30 km/h.

- ▶ Briefly pull the cruise control lever towards you ② or press it up ① or down ③. DISTRONIC PLUS is activated.

Activating at the current speed/last stored speed

WARNING

If you call up a stored speed and this is different from the current speed, the vehicle accelerates or brakes. If you do not know what the stored speed is, the vehicle may

accelerate or brake unexpectedly. There is a risk of an accident.

Take the traffic conditions into account before calling up the stored speed. If you do not know what the stored speed is, store the desired speed again.



- ▶ Briefly pull the cruise control lever towards you ①.
- ▶ Remove your foot from the accelerator pedal.
DISTRONIC PLUS is activated. The first time it is activated, the current speed is stored. Otherwise, it sets the vehicle cruise speed to the previously stored value.

Driving with DISTRONIC PLUS

Pulling away and driving

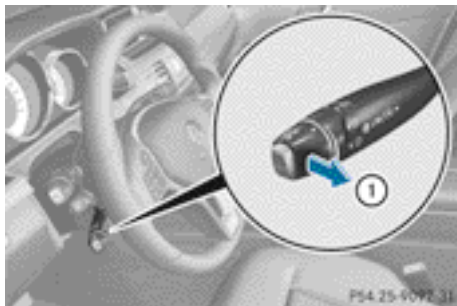

- ▶ **If you want to pull away with DISTRONIC PLUS:** remove your foot from the brake pedal.

- ▶ Briefly pull the cruise control lever towards you ①.

or

- ▶ Accelerate briefly.

Your vehicle pulls away and adapts its speed to that of the vehicle in front.

If no vehicle is detected in front, your vehicle accelerates to the set speed.

- ① The vehicle can also pull away when it is facing an unidentified obstacle or is driving on a different line from another vehicle. The vehicle then brakes automatically. There is a risk of an accident. Be ready to brake at all times.

If there is no vehicle in front, DISTRONIC PLUS operates in the same way as cruise control.

If DISTRONIC PLUS detects that the vehicle in front has slowed down, it brakes your vehicle. In this way, the distance you have selected is maintained.

If DISTRONIC PLUS detects a faster-moving vehicle in front, it increases the driving speed. However, the vehicle is only accelerated up to the speed you have stored.

Selecting the drive program

DISTRONIC Plus supports a sporty driving style when you have selected the **S** driving program (▷ page 190). Acceleration behind the vehicle in front or to the set speed is then noticeably more dynamic. If you have selected the **E** driving program, the vehicle accelerates more gently. This setting is recommended in stop-and-start traffic.

Changing lanes

If you change to the overtaking lane, DISTRONIC PLUS supports you if:

- you are driving faster than 70 km/h
- DISTRONIC PLUS is maintaining the distance to a vehicle in front

- you switch on the respective turn signal
- DISTRONIC PLUS does not detect a danger of collision

If these conditions are met, your vehicle is accelerated. Acceleration will be interrupted if changing lanes takes too long or if the distance between your vehicle and the vehicle in front becomes too small.

- i** When you change lanes, DISTRONIC PLUS monitors the left lane for left-hand-drive vehicles and the right lane for right-hand-drive vehicles.

Vehicles with COMAND Online

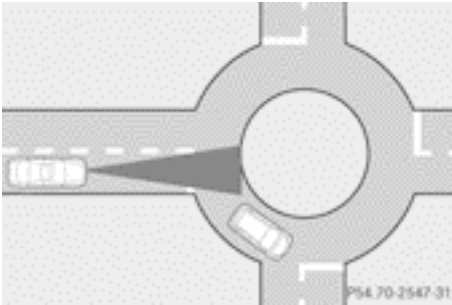

Example: roundabout

- i** The following function is not operational in all countries.

DISTRONIC PLUS uses additional information from your navigation system so that it can adapt to certain traffic situations. This is the case if, while following a vehicle, DISTRONIC PLUS is active and you:

- approach or drive around a roundabout
- approach a T-junction
- turn off at a motorway exit

Even if the vehicle in front leaves the detection range, DISTRONIC PLUS temporarily maintains the current driving speed and does not accelerate. This is based on the current map data in the navigation system.

Afterwards, the vehicle accelerates back to the speed you set.

The system takes into account the fact that overtaking on the right is not permitted on

motorways or high-speed major roads at speeds above 80 km/h. The driving speed is adjusted to the speed of the queue of vehicles in the adjacent lane to the left.

- i** Prevention of overtaking on the right applies to countries where traffic drives on the right. In countries where traffic drives on the left, overtaking on the left is prevented accordingly.

Stopping

WARNING

When leaving the vehicle, even if it is braked only by DISTRONIC PLUS, it could roll away if:

- there is a malfunction in the system or in the voltage supply.
- DISTRONIC PLUS has been deactivated with the cruise control lever, e.g. by a vehicle occupant or from outside the vehicle.
- the electrical system in the engine compartment, the battery or the fuses have been tampered with.
- the battery is disconnected.
- the accelerator pedal has been depressed, e.g. by a vehicle occupant.

There is a risk of an accident.

If you wish to exit the vehicle, always turn off DISTRONIC PLUS and secure the vehicle against rolling away.

Deactivate DISTRONIC PLUS (▷ page 218).

If DISTRONIC PLUS detects that the vehicle in front is stopping, it brakes your vehicle until it is stationary.

Once your vehicle is stationary, it remains stationary and you do not need to depress the brake.

Depending on the specified minimum distance, your vehicle will come to a standstill at a sufficient distance behind the vehicle in front. The specified minimum distance is set using the control on the cruise control lever.

When DISTRONIC PLUS is activated, the transmission is shifted automatically to position **P** if:

- the driver's door is open and the driver's seat belt is unfastened
- the engine is switched off, unless it is automatically switched off by the ECO start/stop function
- a system fault occurs
- the power supply is not sufficient.

Setting a speed

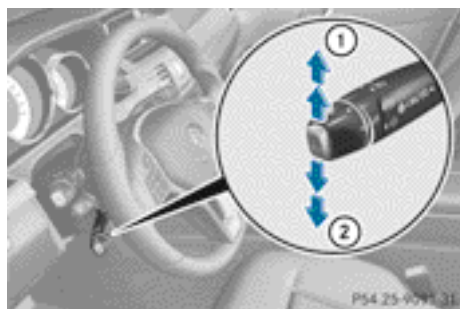

- ▶ Press the cruise control lever up ① for a higher speed or down ② for a lower speed.
- ▶ Keep the cruise control lever pressed until the desired speed is reached.
- ▶ Release the cruise control lever. The new speed is stored. DISTRONIC PLUS is activated and adjusts the vehicle's speed to the new speed stored.
- ▶ **To adjust the set speed in 1 km/h increments:** briefly press the cruise control lever up ① or down ② to the pressure point. The last stored speed increases or decreases in 1 km/h increments.
- ▶ **To adjust the set speed in 10 km/h increments:** press the cruise control lever briefly up ① or down ② beyond the pressure point. The last stored speed increases or decreases in 10 km/h increments.

- ❗ If you accelerate to overtake, DISTRONIC PLUS adjusts the vehicle's speed to the last speed stored after you have finished overtaking.

Setting the specified minimum distance

You can set the specified minimum distance for DISTRONIC PLUS by varying the time span between one and two seconds. With this function, you can set the minimum distance that DISTRONIC PLUS keeps to the vehicle in front, dependent on vehicle speed. You can see this distance in the multifunction display (> page 217).

- ❗ Make sure that you maintain a sufficient distance to the vehicle in front and comply with the minimum distance as required by law. Adjust the distance to the vehicle in front if necessary.

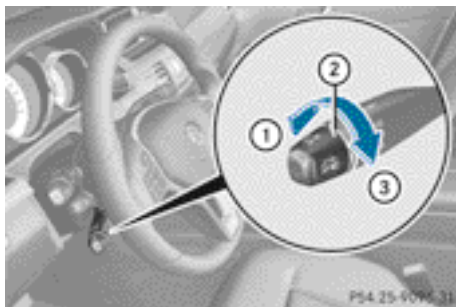

- ▶ **To increase:** turn control ② in direction ③. DISTRONIC PLUS then maintains a greater distance between your vehicle and the vehicle in front.
- ▶ **To decrease:** turn control ② in direction ①. DISTRONIC PLUS then maintains a shorter distance between your vehicle and the vehicle in front.

Displaying DISTRONIC PLUS in the speedometer



Example: vehicles featuring automatic transmission with a DIRECT SELECT lever

When DISTRONIC PLUS is activated, one or two segments ② in the set speed range light up.

If DISTRONIC PLUS detects a vehicle in front, segments ② between speed of the vehicle in front ① and stored speed ③ light up.

- ❗ For design reasons, the speed displayed in the speedometer may differ slightly from the speed set for DISTRONIC PLUS.

Displaying DISTRONIC PLUS in the multifunction display

General notes

In the Assistance menu (▷ page 277) of the on-board computer, you can select the assistance graphic.

Display when DISTRONIC PLUS is deactivated

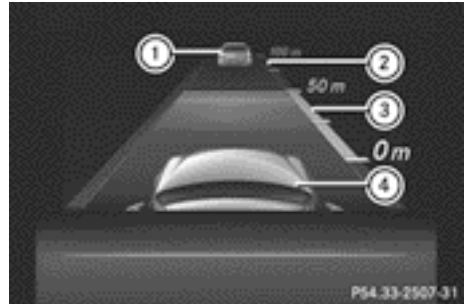

- ① Vehicle in front, if detected
- ② Distance indicator: current distance to the vehicle in front
- ③ Specified minimum distance to the vehicle in front; adjustable
- ④ Own vehicle

- ▶ Select the **Distance display** function using the on-board computer (▷ page 277).

Display when DISTRONIC PLUS is activated



- ① Vehicle in front, if detected
- ② Specified minimum distance to the vehicle in front; adjustable
- ③ Own vehicle
- ④ DISTRONIC PLUS active (text only appears when the cruise control lever is actuated)

- ▶ Select the **Distance display** function using the on-board computer (▷ page 277).

- i** You will see the stored speed for approximately five seconds when you activate DISTRONIC PLUS.

Deactivating DISTRONIC PLUS

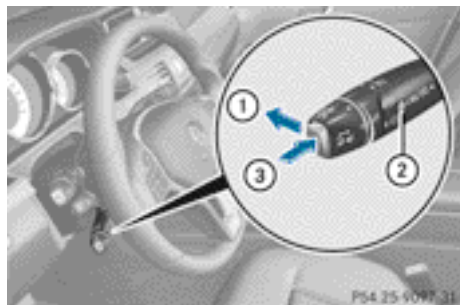

There are several ways to deactivate DISTRONIC PLUS:

- ▶ Briefly press the cruise control lever forwards ①.
 - or
 - ▶ Brake, unless the vehicle is stationary.
 - or
 - ▶ Briefly press the cruise control lever in the direction of arrow ③.
- Variable SPEEDTRONIC is selected. LIM indicator lamp ② in the cruise control lever lights up.

When you deactivate DISTRONIC PLUS, you will see the **DISTRONIC PLUS off** message in the multifunction display for approximately five seconds.

- i** The last speed stored remains stored until you switch off the engine.
- i** DISTRONIC PLUS is not deactivated if you depress the accelerator pedal.

DISTRONIC PLUS is automatically deactivated if:

- you apply the parking brake.
- ESP® intervenes or you deactivate ESP®
- the transmission is in the **P**, **R** or **N** position
- you pull the cruise control lever towards you in order to pull away and the front-

passenger door or one of the rear doors is open

- the vehicle has skidded
- you activate Active Parking Assist

If DISTRONIC PLUS is deactivated, you will hear a warning tone. You will see the **DISTRONIC PLUS off** message in the multifunction display for approximately five seconds.

Tips for driving with DISTRONIC PLUS

General notes

Pay particular attention in the following traffic situations:

- Cornering, going into and coming out of a bend
- Vehicles which are not driving in the middle of their lane
- Other vehicles changing lane
- Narrow vehicles
- Obstructions and stationary vehicles
- Crossing vehicles

In such situations, brake if necessary. DISTRONIC PLUS is then deactivated.

Cornering, going into and coming out of a bend

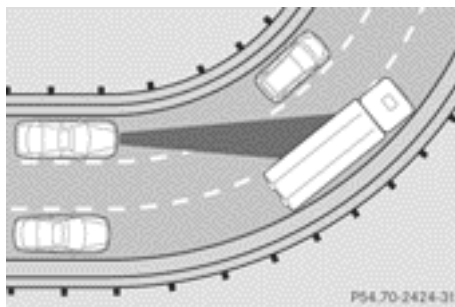

The ability of DISTRONIC PLUS to detect vehicles when cornering is limited. Your vehicle may brake unexpectedly or late.

Vehicles which are not driving in the middle of their lane

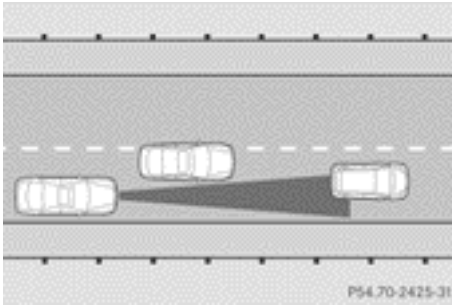

DISTRONIC PLUS may not detect vehicles which are not driving in the middle of their lane. The distance to the vehicle in front is too small.

Other vehicles changing lane

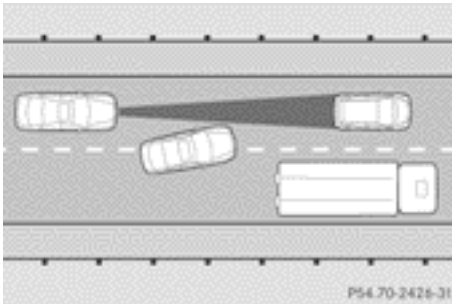

DISTRONIC PLUS has not detected the vehicle cutting in yet. The distance to this vehicle is too small.

Narrow vehicles

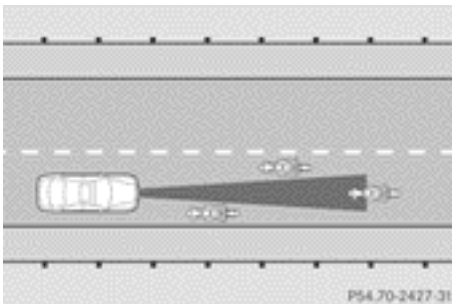

DISTRONIC PLUS has not yet detected the vehicle in front on the edge of the carriageway, because of its narrow width. The distance to the vehicle in front is too small.

Obstructions and stationary vehicles

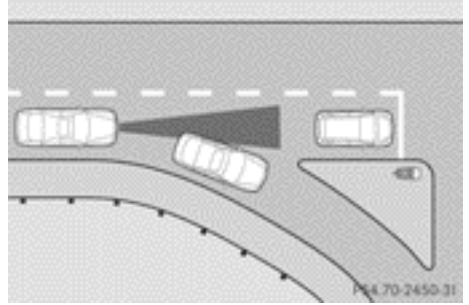

DISTRONIC PLUS does not brake for obstacles or stationary vehicles. If, for example, the detected vehicle turns a corner and reveals an obstacle or stationary vehicle, DISTRONIC PLUS will not brake for these.

Crossing vehicles

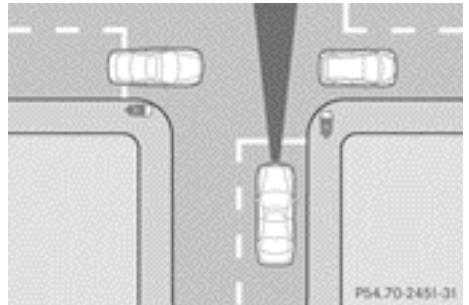

DISTRONIC PLUS may mistakenly detect vehicles that are crossing your lane. Activating DISTRONIC PLUS at traffic lights with crossing traffic, for example, could cause your vehicle to pull away unintentionally.

DISTRONIC PLUS with Steering Assist

General notes

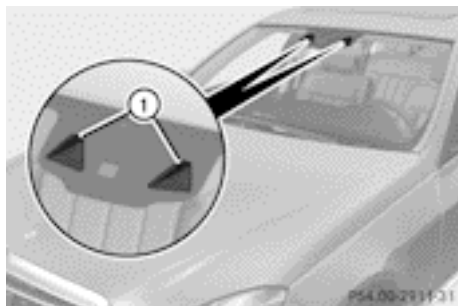

DISTRONIC PLUS Steering Assist aids you in keeping the vehicle in the centre of the driving lane by means of moderate steering interventions at speeds of 0 - 200 km/h.

DISTRONIC PLUS Steering Assist monitors the area in front of your vehicle by means of camera system ①, at the top of the windscreen.

At speeds of more than 60 km/h DISTRONIC PLUS Steering Assist focuses on lane markings that are present.

At speeds of 0 - 60 km/h DISTRONIC PLUS Steering Assist focuses on the vehicle in front, taking into account lane markings, e.g. when following vehicles in a traffic jam.

DISTRONIC PLUS must be active in order for the Steering Assist function to be available.

Important safety notes

If you fail to adapt your driving style, DISTRONIC PLUS Steering Assist can neither reduce the risk of an accident nor override the laws of physics. DISTRONIC PLUS Steering Assist cannot take into account road, weather or traffic conditions. DISTRONIC PLUS Steering Assist is only an aid. You are responsible for the distance to the vehicle in front, for vehicle speed, for braking in good time, and for staying in the lane.

DISTRONIC PLUS Steering Assist does not detect road and traffic conditions. If you are following a vehicle which is driving towards the edge of the carriageway, your vehicle

could come into contact with the curb or other road boundaries. In the case of deviations in road markings, beware of other road users, e.g. cyclists, that are directly next to your vehicle.

Obstacles such as traffic pylons on the lane or projecting out into the lane are not detected.

An inappropriate steering intervention, e.g. after intentionally driving over a lane marking, can be corrected at any time if you steer slightly in the opposite direction.

DISTRONIC PLUS Steering Assist cannot continuously keep your vehicle in lane. In some cases, the steering intervention is not sufficient to bring the vehicle back to the lane. In such cases, you must steer the vehicle yourself to ensure that it does not leave the lane.

The system may be impaired or may not function if:

- there is poor visibility, e.g. due to insufficient illumination of the road, or due to snow, rain, fog or spray
- there is glare, e.g. from oncoming traffic, the sun or reflection from other vehicles (e.g. if the road surface is wet)
- the windscreen is dirty, misted up, damaged or covered, for instance by a sticker, in the vicinity of the camera
- no, or several, unclear lane markings are present for one lane, e.g. in a construction area
- the lane markings are worn away, dark or covered up, e.g. by dirt or snow
- the distance to the vehicle in front is too small and the lane markings thus cannot be detected
- the lane markings change quickly, e.g. lanes branch off, cross one another or merge
- the road is narrow and winding
- there are highly variable shade conditions on the road

Pay attention also to the important safety notes for DISTRONIC PLUS (▷ page 211).

The steering interventions are carried out with a limited steering moment. The system requires the driver to keep his hands on the steering wheel and to steer himself.

If you do not steer yourself or if take your hands off the steering wheel for a prolonged period of time, the system will first alert you with a visual warning. A steering wheel symbol appears in the multifunction display. If you have still not started to steer and have not taken hold of the steering wheel after five seconds, a warning tone also sounds to remind you to take control of the vehicle. DISTRONIC PLUS Steering Assist is then switched to passive. DISTRONIC PLUS remains active.

The system is switched to passive and no longer assists you by performing steering interventions if:

- you actively change lanes
- you switch on the turn signal
- you take your hands off the steering wheel or do not steer for a prolonged period of time

i After you have finished changing lanes, DISTRONIC PLUS Steering Assist is automatically active once more.

DISTRONIC PLUS Steering Assist does not provide assistance:

- on very sharp corners
- if no lane markings or no clear lane markings have been detected
- if the vehicle in front is not detected at speeds below 60 km/h
- when towing a trailer
- in tyre run-flat mode

Activating Steering Assist

► Select the DISTRONIC PLUS with Steering Assist function using the on-board computer (► page 279).

The **DTR+: steering assistant On** message appears in the multifunction display. DISTRONIC PLUS Steering Assist is activated.

Information in the multifunction display



If DISTRONIC PLUS Steering Assist is activated but is not ready for a steering intervention, steering wheel symbol ① appears in grey. If the system provides you with support by means of steering interventions, symbol ① is shown in green.

Deactivating Steering Assist

► Deactivate the DISTRONIC PLUS with Steering Assist function using the on-board computer (► page 279).

The **DTR+: steering assistant On** message appears in the multifunction display. DISTRONIC PLUS Steering Assist is deactivated.

When DISTRONIC PLUS is deactivated, DISTRONIC PLUS Steering Assist is deactivated automatically.

HOLD function

General notes

The HOLD function can assist the driver in the following situations:

- when pulling away, especially on steep slopes
- when manoeuvring on steep slopes
- when waiting in traffic

The vehicle is kept stationary without the driver having to depress the brake pedal.

The braking effect is cancelled and the HOLD function is deactivated when you depress the accelerator pedal to pull away.

Important safety notes

WARNING

When leaving the vehicle, it can still roll away despite being braked by the HOLD function if:

- there is a malfunction in the system or in the voltage supply
- the HOLD function is deactivated by the accelerator pedal being depressed, e.g. by a vehicle occupant
- the electrical system in the engine compartment, the battery or the fuses are tampered with
- the battery is disconnected

There is a risk of an accident.

Before leaving the vehicle, always deactivate the HOLD function and secure the vehicle from rolling away.

! If DISTRONIC PLUS or the HOLD function is activated, the vehicle brakes automatically in certain situations. To prevent damage to the vehicle, deactivate DISTRONIC PLUS and the HOLD function in the following or other similar situations:

- when towing the vehicle
- in the car wash

Activation conditions

You can activate the HOLD function if:

- the vehicle is stationary.
- the engine is running or if it has been automatically switched off by the ECO start/stop function.
- the driver's door is closed or if your seat belt is fastened.
- the parking brake is released.
- the selector lever is in position **D**, **R** or **N** on vehicles with automatic transmission.
- DISTRONIC PLUS is deactivated.

Activating the HOLD function



- ▶ Make sure that the activation conditions are met.
- ▶ Depress the brake pedal.
- ▶ Quickly depress the brake pedal further until **HOLD** ① appears in the multifunction display.
The HOLD function is activated. You can release the brake pedal.

i If depressing the brake pedal the first time does not activate the HOLD function, wait briefly and then try again.

Deactivating the HOLD function

The HOLD function is deactivated automatically if:

- you accelerate. On vehicles with automatic transmission: only when the transmission is in position **D** or **R**.
- you shift the transmission to position **P** on vehicles with automatic transmission.
- you depress the brake pedal again with a certain amount of pressure until **HOLD** disappears from the multifunction display.
- you activate DISTRONIC PLUS.

When the HOLD function is activated, the automatic transmission is automatically shifted to position **P** if:

- the driver's door is open and the driver's seat belt is unfastened
- the engine is switched off, unless it is automatically switched off by the ECO start/stop function
- a system fault occurs
- the power supply is not sufficient

On vehicles with a manual transmission, you will see a warning message in the multifunction display in such cases:

Brake immediately

- ▶ Immediately depress the brake pedal firmly until the warning message in the multifunction display goes out. This deactivates the HOLD function.

On vehicles with a manual transmission, you will also hear a horn at regular intervals if the HOLD function is activated and you:

- switch the engine off, open the driver's door and take off your seat belt

The sounding of the horn alerts you to the fact that the vehicle has been parked while the HOLD function is still activated. If you attempt to lock the vehicle, the tone becomes louder. The vehicle is not locked until the HOLD function is deactivated.

- i** If the engine has been switched off, it cannot be started again until the HOLD function has been deactivated.

RACE START

Important safety notes

- i** Observe the safety notes for the SPORT handling mode (▷ page 79).

Only activate RACE START on dedicated race circuits.

RACE START enables optimum acceleration from a standing start. The precondition for this is a suitable high-grip road surface.

- i** RACE START is only available in AMG vehicles.

Activation conditions

You can activate RACE START if:

- the doors are closed.
- the engine is running and it has reached an operating temperature of approximately 80 °C. This is the case when the engine oil

temperature in the multifunction display stops flashing.

- SPORT handling mode is activated (▷ page 79).
- the steering wheel is in the straight-ahead position
- the vehicle is stationary and the brake pedal is depressed (left foot).
- the transmission is in position **D**

Activating RACE START

- ▶ Depress the brake pedal with your left foot and keep it depressed.
- ▶ Turn the drive program selector clockwise (▷ page 190) until the **RS** lamp lights up. The **RACE START Confirm: Paddle UP Cancel: Paddle DOWN** message appears in the multifunction display.

- i** If the activation conditions are no longer fulfilled, RACE START is cancelled. The **RACE START cancelled** message appears in the multifunction display.

- ▶ To cancel: pull the left steering wheel shift paddle (▷ page 191).

or

- ▶ To confirm: pull the right steering wheel shift paddle (▷ page 191). The **RACE START available Depress accelerator** message appears in the multifunction display.

- i** If you do not depress the accelerator pedal fully within two seconds, RACE START is cancelled. The **RACE START not possible See Owner's Manual** message appears in the multifunction display.

- ▶ Fully depress the accelerator pedal. The engine speed rises to approximately 3,500 rpm.

The **RACE START Release brake to start** message appears in the multifunction display.

- i** If you do not release the brake pedal within five seconds, RACE START is cancel-

led. The **RACE START cancelled** message appears in the multifunction display.

- ▶ Take your foot off the brake, but keep the accelerator pedal depressed. The vehicle pulls away at maximum acceleration.

The **RACE START active** message appears in the multifunction display.

RACE START is deactivated when the vehicle reaches a speed of approximately 50 km/h. Drive program **S+** is activated. SPORT handling mode remains activated.

RACE START is deactivated immediately if you release the accelerator pedal during RACE START or if any of the activation conditions are no longer fulfilled. The **RACE START not possible** See *Owner's Manual* message appears in the multifunction display.

- ❗ After using it several times in short succession, RACE START will be unavailable until a certain distance has been driven.

AIRMATIC

Vehicle level

Important safety notes

WARNING

People's limbs may become trapped if they are located underneath the vehicle or between the vehicle body and the tyres when the vehicle is lowering. There is a danger of injury.

When lowering the vehicle, make sure no one is underneath the vehicle or in the immediate vicinity of the wheel arches.

WARNING

Vehicles with level control:

The vehicle is slightly lowered if you:

- have selected comfort suspension tuning and
- you lock the vehicle within approximately 60 seconds of switching off the engine

You and people in the vicinity of the wheel arch or the underbody may thus become trapped. There is a risk of injury.

Make sure that nobody is in the vicinity of the wheel arch or the underbody when you lock the vehicle.

- ❗ The vehicle is lowered by about 15 mm if:

- you have selected "Comfort tuning"
- you switch off the engine and
- you lock the vehicle within approximately 60 seconds

When parking, position your vehicle so that it does not make contact with the kerb as the vehicle is lowered. Your vehicle could otherwise be damaged.

If you unlock the vehicle within 60 seconds of having switched the engine off, the vehicle is lowered slightly when Comfort suspension mode is selected.

Observe the notes on driving with a trailer (▷ page 260).

Your vehicle regulates its height automatically. All-round level control ensures the best possible suspension and constant ground clearance, even with a laden vehicle. When you drive fast, the vehicle is lowered automatically to improve driving safety and to reduce fuel consumption.

The following vehicle levels are possible:

- Normal
- Raised (vehicles without 4MATIC): the vehicle is raised by approximately 25 mm when compared with the normal level
- Raised (vehicles with 4MATIC): the vehicle is raised by approximately 35 mm when compared with the normal level
- Lowered: the vehicle is lowered by approximately 10 mm when compared with the normal level

The "Normal" and "Raised" vehicle levels can be set manually.

The "Lowered" vehicle level is set automatically:

- at speeds above 140 km/h
- if you have selected "Sports mode" (▷ page 225)

Setting the vehicle level

Select the "Normal" setting for normal road surfaces and "Raised" for driving with snow chains or on particularly poor road surfaces. Your selection remains stored even if you remove the key from the ignition lock.

Setting raised level

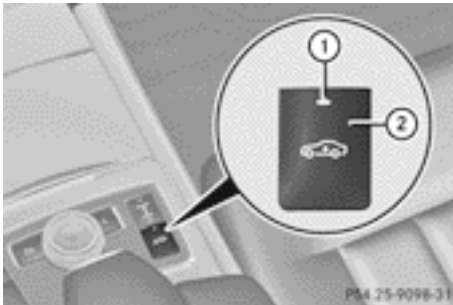

- ▶ Start the engine.

If indicator lamp ② is not lit:

- ▶ Press button ②. Indicator lamp ① lights up. The vehicle height is adjusted to raised level.

The **Vehicle rising** message appears in the display.

The "Raised level" setting is cancelled if you:

- drive at a speed over approximately 120 km/h
- drive for approximately three minutes at a speed over 80 km/h

The "Raised level" remains saved when you are not driving within these speed ranges.

Setting the normal level

- ▶ Start the engine.

If indicator lamp ① is lit:

- ▶ Press button ②. Indicator lamp ① goes out. The vehicle is adjusted to normal level.

Suspension tuning

General notes

The electronically controlled damping system works continuously. This improves driving safety and ride comfort.

The damping is tuned individually to each wheel and depends on:

- your driving style, e.g. sporty
- the road surface condition, e.g. bumps
- your individual selection, i.e. sports or comfort

Your selection remains stored even if you remove the key from the ignition lock.

Sports mode

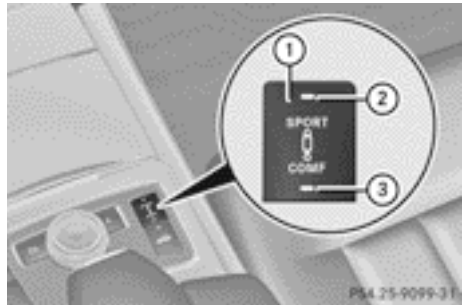

The firmer suspension tuning in Sport mode ensures even better contact with the road. Select this mode when employing a sporty driving style, e.g. on winding country roads.

- ▶ Press button ①. Indicator lamp ② lights up. You have selected "Sports mode".

The **AIRMATIC SPORT** message appears in the multifunction display.

Comfort mode

In Comfort mode, the driving characteristics of your vehicle are more comfortable. Therefore, select this mode if you prefer a more comfortable driving style. Select Comfort mode also when driving fast on straight roads, e.g. on straight stretches of motorway.

► Press button ①.

Indicator lamp ③ lights up. You have selected "Comfort mode".

The **AIRMATIC COMFORT** message appears in the multifunction display.

AMG RIDE CONTROL sports suspension

Important safety notes

⚠ WARNING

People's limbs may become trapped if they are located underneath the vehicle or between the vehicle body and the tyres when the vehicle is lowering. There is a danger of injury.

When lowering the vehicle, make sure no one is underneath the vehicle or in the immediate vicinity of the wheel arches.

⚠ WARNING

Vehicles with level control:

The vehicle is slightly lowered if you:

- have selected comfort suspension tuning and
- you lock the vehicle within approximately 60 seconds of switching off the engine

You and people in the vicinity of the wheel arch or the underbody may thus become trapped. There is a risk of injury.

Make sure that nobody is in the vicinity of the wheel arch or the underbody when you lock the vehicle.

❗ The vehicle is lowered by about 20 mm if:

- you have selected "Comfort tuning"
- you switch off the engine and
- you lock the vehicle within approximately 60 seconds

When parking, position your vehicle so that it does not make contact with the kerb as the vehicle is lowered. Your vehicle could otherwise be damaged.

Suspension tuning

General notes

The electronically controlled damping system works continuously. This improves driving safety and ride comfort.

The damping is tuned individually to each wheel and depends on:

- your driving style, e.g. sporty
- the road surface condition, e.g. bumps
- your individual selection of Sport, Sport + or Comfort

Sport mode



- ① Button for mode selection
- ② Button for saving, calling up and displaying the selected mode
- ③ Sport + mode indicator lamp
- ④ Sport mode indicator lamp

The firmer suspension tuning in Sport mode ensures better contact with the road. Select this mode when employing a sporty driving style, e.g. on winding country roads.

- ▶ Press button ① once.
Indicator lamp ④ lights up. You have selected Sport mode.
The **AMG Ride Control SPORT** message appears in the multifunction display.

Sport + mode

The very firm setting of the suspension tuning in Sport + mode ensures the best possible contact with the road. Select this mode primarily when driving on race circuits.

If indicator lamps ③ and ④ are off:

- ▶ Press button ① twice.
Indicator lamps ③ and ④ light up. You have selected Sport + mode.
The **AMG Ride Control SPORT +** message appears in the multifunction display.

If indicator lamp ④ lights up:

- ▶ Press button ① once.
Second indicator lamp ③ lights up. You have selected Sport + mode.
The **AMG Ride Control SPORT +** message appears in the multifunction display.

Comfort mode

When comfort mode is selected, the driving characteristics of your vehicle are more comfortable. Select this mode if you prefer a comfort-oriented driving style. Select comfort mode also when driving fast on straight roads, e.g. on straight stretches of motorway.

- ▶ Press button ① repeatedly until indicator lamps ③ and ④ go out.
You have selected Comfort mode.
The **AMG Ride Control COMFORT** message appears in the multifunction display.

Storing and calling up settings

Once the suspension tuning and drive program have been selected, you can store and call up your settings using AMG button ②.

- ▶ **To store:** press AMG button ② until you hear a tone.

- ▶ **To call up:** press AMG button ②.
The stored suspension tuning and drive program are selected.
- ▶ **To display:** briefly press AMG button ②.
Your selection appears in the multifunction display.

Vehicle level

Important safety notes

WARNING

People's limbs may become trapped if they are located underneath the vehicle or between the vehicle body and the tyres when the vehicle is lowering. There is a danger of injury.

When lowering the vehicle, make sure no one is underneath the vehicle or in the immediate vicinity of the wheel arches.

The vehicle lowers when you press the button for selecting the suspension tuning or the AMG button. The vehicle also lowers if it is stationary.

- ❗ If Sport or Sport + suspension tuning has been selected, the vehicle's ground clearance decreases. Make sure that no objects become trapped or that the vehicle has not been damaged, for example, on the kerb.

- ❗ The vehicle level may change visibly at the rear axle if you park the vehicle and the outside temperature changes. If the temperature drops, the vehicle level lowers; with an increase in temperature, the vehicle level rises.

Changing the rear axle ride height

This function is only available for the E 63 AMG 4MATIC.

The vehicle level at the rear axle depends on the selected suspension tuning and the vehicle speed.

The vehicle level at the rear axle changes during the journey depending on the selected suspension tuning:

- Comfort: +10 mm
- Sport + and Sport: -15 mm

When switching from Comfort to Sport or Sport +, the rear axle lowers by approximately 25 mm. When switching from Sport or Sport + to Comfort, the rear axle raises by approximately 25 mm. This level change also takes place when the vehicle is stationary.

If you drive faster than 170 km/h, the rear axle ride height is set to a medium level. This increases driving safety and reduces air resistance. If you then drive at speeds below 150 km/h, the rear axle ride height is readjusted to the selected suspension tuning.

Load compensation

The vehicle can compensate differences in the vehicle level by raising or lowering the rear axle. This is the case, for example, if people get out or if luggage is being loaded.

Load compensation takes place if:

- a door or the boot lid/tailgate is opened
- the parked vehicle is unlocked

For larger level changes, the engine must be running.

4MATIC (permanent all-wheel drive)

If you fail to adapt your driving style, 4MATIC can neither reduce the risk of accident nor override the laws of physics. 4MATIC cannot take account of road, weather and traffic conditions. 4MATIC is only an aid. You are responsible for the distance to the vehicle in front, for vehicle speed, for braking in good time, and for staying in the lane.

If a drive wheel spins due to insufficient grip:

- when pulling away, only depress the accelerator pedal as far as is necessary
- accelerate less when driving

⚠ Never tow the vehicle with one axle raised. This may damage the transfer case. Damage of this sort is not covered by the Mercedes-Benz implied warranty. All wheels must remain either on the ground or be fully raised. Observe the instructions for towing the vehicle with all wheels in full contact with the ground.

i In wintry driving conditions, the maximum effect of 4MATIC can only be achieved if you use winter tyres (M+S tyres), with snow chains if necessary.

4MATIC ensures that all four wheels are permanently driven. Together with ESP®, it improves the traction of your vehicle whenever a drive wheel spins due to insufficient grip.

PARKTRONIC

Important safety notes

PARKTRONIC is an electronic parking aid with ultrasonic sensors. It indicates visually and audibly the distance between your vehicle and an object.

PARKTRONIC is only an aid. It is not a substitute for your attention to the immediate surroundings. The responsibility for safe manoeuvring and parking remains with you. Make sure that there are no persons, animals or objects in range while manoeuvring and parking.

⚠ When parking, pay particular attention to objects above or below the sensors, such as flower pots or trailer drawbars. PARKTRONIC does not detect such objects when they are in the immediate vicinity of the vehicle. You could damage the vehicle or the objects.

The sensors may not detect snow and objects which absorb ultrasonic sources. Ultrasonic sources, such as an automatic car wash, a lorry's compressed-air brakes or a pneumatic drill, could cause PARKTRONIC to malfunction.

PARKTRONIC may not function correctly on uneven terrain.

PARKTRONIC is activated automatically if you:

- switch on the ignition
- shift to position **D**, **R** or **N** on vehicles with automatic transmission
- release the parking brake

PARKTRONIC is deactivated at speeds above 18 km/h. It is reactivated at lower speeds.

PARKTRONIC monitors the area around your vehicle using six sensors in the front bumper and six sensors in the rear bumper.

Range of the sensors

General notes

PARKTRONIC does not take into account obstacles located:

- below the detection range, e.g. persons, animals or objects
- above the detection range, e.g. overhanging loads, tail sections or loading ramps of goods vehicles

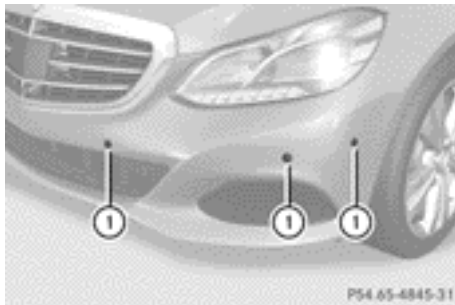

① Example: sensors in the front bumper, left-hand side

The sensors must be free of dirt, ice and slush. Otherwise, they may not function correctly. Clean the sensors regularly, taking care not to scratch or damage them (▷ page 375).

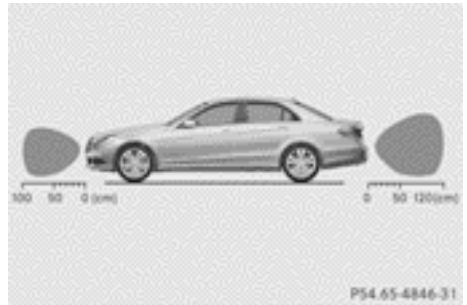

Example: side view

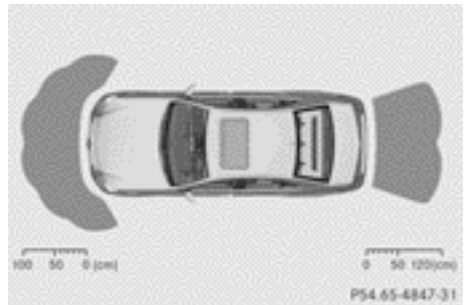

Example: top view

Front sensors

Centre	Approx. 100 cm
Corners	Approx. 60 cm

Rear sensors

Centre	Approx. 120 cm
Corners	Approx. 80 cm

Minimum distance

Centre	Approx. 20 cm
Corners	Approx. 15 cm

If there is an obstacle within this range, the relevant warning displays light up and a warning tone sounds. If the distance falls below the minimum, the distance may no longer be shown.

Warning displays

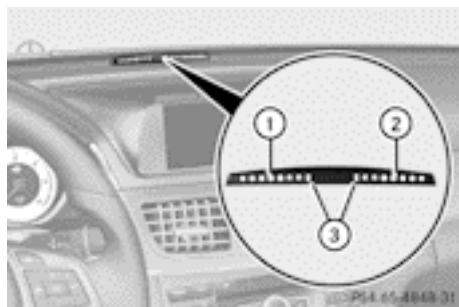

Warning display for the front area

- ① Segments on the left-hand side of the vehicle
- ② Segments on the right-hand side of the vehicle
- ③ Segments showing operational readiness

The warning displays show the distance between the sensors and the obstacle. The warning display for the front area is located on the dashboard above the centre air vents. The warning display for the rear area is located on the roof lining in the rear compartment.

The warning display for each side of the vehicle is divided into five yellow and two red segments. PARKTRONIC is operational if yellow segments showing operational readiness ③ light up.

The gear lever position or the transmission position of the automatic transmission and the direction in which the vehicle is rolling determine which warning display is active when the engine is running.

Manual transmission:

Gear lever position	Warning display
Forward gear or Neutral	Front area activated
Reverse gear	Rear and front areas activated

Automatic transmission:

Transmission position	Warning display
D	Front area activated
R or N	Rear and front areas activated
P	No areas activated

One or more segments light up as the vehicle approaches an obstacle, depending on the vehicle's distance from the obstacle.

From the:

- sixth segment onwards, you will hear an intermittent warning tone for approximately two seconds
- seventh segment onwards, you will hear a warning tone for approximately two seconds. This indicates that you have now reached the minimum distance.

Deactivating/activating PARKTRONIC

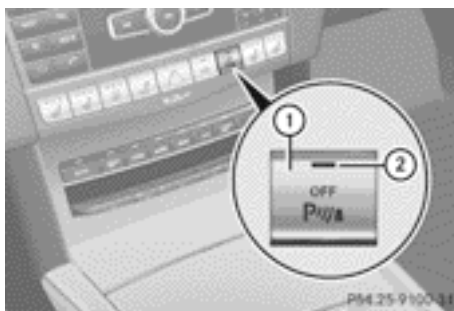

- ① Deactivating/activating PARKTRONIC
- ② Indicator lamp

If indicator lamp ② lights up, PARKTRONIC is deactivated. Active Park Assist is then also deactivated.

- i** PARKTRONIC is automatically activated when you turn the key to position **2** in the ignition lock.

Towing a trailer

! Fold in the ball coupling if the trailer tow hitch is not required. PARKTRONIC measures the minimum detection range to an obstacle from the bumper, not the ball coupling.

PARKTRONIC is deactivated for the rear area when you establish an electrical connection between your vehicle and a trailer.

Problems with PARKTRONIC

Problem	Possible causes/consequences and ► Solutions
Only the red segments in the PARKTRONIC warning displays are lit. You also hear a warning tone for approximately two seconds. PARKTRONIC is then deactivated and the indicator lamp on the PARKTRONIC button lights up.	PARKTRONIC has malfunctioned and has switched off. ► If problems persist, have PARKTRONIC checked at a qualified specialist workshop.
Only the red segments in the PARKTRONIC warning displays are lit. PARKTRONIC is then deactivated.	The PARKTRONIC sensors are dirty or there is interference. ► Clean the PARKTRONIC sensors (► page 375). ► Switch the ignition back on.
	The problem may be caused by an external source of radio or ultrasound waves. ► See if PARKTRONIC functions in a different location.

Active Parking Assist

General notes

Active Parking Assist is an electronic parking aid with ultrasound. It measures the road on both sides of the vehicle. A parking symbol indicates a suitable parking space. Active steering intervention and brake application can assist you during parking. You may also use PARKTRONIC (► page 228).

- i** The active braking application is only available on vehicles with automatic transmission.

Important safety notes

Active Parking Assist is only an aid. It is not a substitute for your attention to the immediate surroundings. The responsibility for safe manoeuvring and parking remains with you. Make sure that no persons, animals or objects are in the manoeuvring range.

When PARKTRONIC is switched off, Active Parking Assist is also unavailable.

WARNING

While parking or pulling out of a parking space, the vehicle swings out and can drive onto areas of the oncoming lane. This could cause you to collide with other road users. There is a risk of an accident.

Pay attention to other road users. Stop the vehicle if necessary or cancel the Active Parking Assist parking procedure.

- !** If unavoidable, you should drive over obstacles such as kerbs slowly and not at a sharp angle. Otherwise, you may damage the wheels or tyres.

Active Parking Assist may also display spaces not suitable for parking, e.g.:

- parking or stopping prohibitions
- in front of driveways or entrances and exits
- unsuitable surfaces

Parking tips:

- on narrow roads, drive as closely as possible past the parking space.
- parking spaces that are littered or overgrown might be identified or measured incorrectly.
- parking spaces that are partially occupied by trailer drawbars might not be identified as such or be measured incorrectly.
- snowfall or heavy rain may lead to a parking space being measured inaccurately.
- pay attention to the PARKTRONIC (> page 230) warning messages during the parking procedure.
- at any time, you can intervene in the steering procedure to correct it. Active Parking Assist will then be cancelled.
- when transporting a load which protrudes from your vehicle, you should not use Active Parking Assist.
- never use Active Parking Assist when snow chains are fitted.
- make sure that the tyre pressures are always correct. This has a direct influence on the parking characteristics of the vehicle.

Use Active Parking Assist for parking spaces:

- that are parallel or at right angles to the direction of travel
- that are on straight roads, not bends
- that are on the same level as the road, e.g. not on the pavement

Detecting parking spaces

Objects located above the height range of Active Parking Assist will not be detected when the parking space is measured. These are not taken into account when the parking procedure is calculated, e.g. overhanging loads, tail sections or loading ramps of goods vehicles.

WARNING

If there are objects above the detection range:

- Active Park Assist may steer too early
- the vehicle may not stop in front of these objects.

This could cause a collision. There is a risk of an accident.

If objects are located above the detection range, stop and switch off Active Parking Assist.

For further information on the detection range (> page 229).

Active Parking Assist does not support you with parking spaces at right angles to the direction of travel if:

- two parking spaces are located directly next to one another
- the parking space is directly next to a low obstacle such as a low kerb stone
- you park forwards.

Active Parking Assist does not support you with parking spaces that are parallel or at right angles to the direction of travel if:

- the parking space is on a kerb stone
- the system reads the parking space as being blocked, for example by foliage or grass paving blocks
- the area is too small for the vehicle to manoeuvre into
- the parking space is bordered by an obstacle, e.g. a tree, a post or a trailer.



Example: detected parking space



- ① Detected parking space on the left
- ② Parking symbol
- ③ Detected parking space on the right

Active Parking Assist is switched on automatically when driving forwards. The system is operational at speeds of up to approximately 35 km/h. While in operation, the system independently locates and measures parking spaces on both sides of the vehicle.

Active Parking Assist will only detect parking spaces:

- that are parallel or at right angles to the direction of travel
- that are parallel to the direction of travel and are at least 1.5 m wide
- that are parallel to the direction of travel and at least 1.0 m longer than your vehicle
- that are at right angles to the direction of travel and at least 1.0 m wider than your vehicle

i In the case of parking spaces that are at right angles to the direction of travel, please ensure that the parking space is long enough to accommodate your vehicle.

When driving at speeds below 30 km/h, you will see parking symbol  as a status indicator in the instrument cluster. When a parking space has been detected, an arrow towards the right or the left also appears. Active Parking Assist only displays parking spaces on the front-passenger side as standard. Parking spaces on the driver's side are displayed as soon as the turn signal on the driver's side is activated. When parking on the driver's side, this must remain switched on until you acknowledge the use of Active Parking Assist by pressing the  button on the multifunction steering wheel. The system automatically determines whether the parking space is parallel or at right angles to the direction of travel.

A parking space is displayed while you are driving past it, and until you are approximately 15 m away from it.

Parking

i Vehicles with automatic transmission:
When PARKTRONIC detects obstacles, Active Parking Assist brakes automatically during the parking process. You are responsible for braking in good time.

► Stop the vehicle when the parking symbol shows the desired parking space in the instrument cluster.

► Vehicles with manual transmission: shift to reverse gear.

Vehicles with automatic transmission: shift into position **R**.

The **Start Park Assist? Yes: OK No:**

 message appears in the multifunction display.

► **To cancel the procedure:** press the

 button on the multifunction steering wheel or pull away.

or

► **To park using Active Parking Assist:**

press the  button on the multifunction steering wheel.

The **Park Assist active Accelerate and brake Observe surroundings** message appears in the multifunction display.

► Release the multifunction steering wheel.

► Reverse the vehicle, being ready to brake at all times. When reversing, drive at a speed below 10 km/h. Otherwise, Active Parking Assist will be cancelled.

Vehicles with automatic transmission:

Active Parking Assist brakes the vehicle to a standstill when the vehicle is in the parking space.

Manoeuvring may be required in tight parking spaces.

► **Vehicles with manual transmission:**

stop as soon as PARKTRONIC sounds the continuous warning tone, if not before.

Manoeuvring may be required in tight parking spaces.

Vehicles with manual transmission: the **Park Assist active Engage forward**

gear **Observe surroundings** message appears in the multifunction display.

Vehicles with automatic transmission: the **Park Assist active Select D Observe surroundings** message appears in the multifunction display.

► **Vehicles with manual transmission:** shift to first gear while the vehicle is stationary.

Vehicles with automatic transmission: select transmission position **D** while the vehicle is stationary.

Active Parking Assist immediately steers in the other direction.

The **Park Assist active Accelerate and brake Observe surroundings** message appears in the multifunction display.

i You will achieve the best results by waiting for the steering procedure to complete before pulling away.

► Drive forwards and be ready to brake at all times.

Vehicles with automatic transmission: Active Parking Assist brakes the vehicle to a standstill.

► **Vehicles with manual transmission:** stop, at the latest when PARKTRONIC sounds the continuous warning tone.

Vehicles with manual transmission: the **Park Assist active Engage reverse gear Observe surroundings** message appears in the multifunction display.

Vehicles with automatic transmission: the **Park Assist active Select R Observe surroundings** message appears in the multifunction display.

Additional transmission shifts may be necessary.

As soon as the parking procedure is complete, the **Park Assist switched off** message appears in the multifunction display and you will hear a tone. The vehicle is now parked. The vehicle is kept stationary without the driver having to depress the brake pedal.

The braking effect is cancelled when you depress the accelerator pedal.

Active Parking Assist no longer supports you with steering interventions and brake applications. When Active Parking Assist is finished, you must steer and brake again yourself. PARKTRONIC is still available.

► Manoeuvre if necessary.

► Always observe the warning messages displayed by PARKTRONIC (▷ page 230).

Parking tips:

- The way your vehicle is positioned in the parking space after parking is dependent on various factors. These include the position and shape of the vehicles parked in front and behind it and the conditions of the location. It may be the case that Active Parking Assist guides you too far into a parking space, or not far enough into it. In some cases, it may also lead you across or onto the kerb. If necessary, you should cancel the parking procedure with Active Parking Assist.
- You can also engage forward gear prematurely. The vehicle redirects and does not drive as far into the parking space. Should a gear be changed too early, the parking procedure will be cancelled. A sensible parking position can no longer be achieved from this position.

Exiting a parking space

In order that Active Parking Assist can support you when you exit the parking space:

- the border of the parking space must be high enough at the front and the rear. A kerb stone is too small, for example.
- the border of the parking space must not be too wide, as the position of the vehicle must not exceed an angle of 45° to the starting position as it is manoeuvred into the parking space.
- a manoeuvring distance of at least 1.0 m must be available.

- i** Vehicles with automatic transmission:
If PARKTRONIC detects obstacles, Active Parking Assist brakes automatically whilst the vehicle exits the parking space. You are responsible for braking in good time.

Active Parking Assist can only assist you with exiting a parking space if you have parked the vehicle parallel to the direction of travel using Active Parking Assist.

- ▶ Start the engine.
- ▶ Switch on the turn signal in the direction you are pulling away.

- ▶ **Vehicles with manual transmission:** engage first or reverse gear.

Vehicles with automatic transmission:

shift the transmission to position **D** or **R**.
The **Start Park Assist? Yes: OK No:**

 message appears in the multifunction display.

- ▶ **To cancel the procedure:** press the  button on the multifunction steering wheel or pull away.

or

- ▶ **To exit a parking space using Active Parking Assist:** press the  button on the multifunction steering wheel.

The **Park Assist active Accelerate and brake Observe surroundings** message appears in the multifunction display.

- ▶ Release the multifunction steering wheel.
- ▶ Pull away, being ready to brake at all times. Do not exceed a maximum speed of approximately 10 km/h when exiting a parking space. Otherwise, Active Parking Assist will be cancelled.

- ▶ **Vehicles with manual transmission:** stop, at the latest when PARKTRONIC sounds the continuous warning tone.

- ▶ **Vehicles with manual transmission:** engage first gear or reverse gear when the vehicle is stationary, depending on the message or requirement.

Vehicles with automatic transmission: shift the transmission to position **D** or **R**

when the vehicle is stationary, depending on the message or requirement.

Active Parking Assist immediately steers in the other direction. The **Park Assist active Accelerate and brake Observe surroundings** message appears in the multifunction display.

- i** You will achieve the best results by waiting for the steering procedure to complete before pulling away.

If you reverse after activation, the steering wheel is moved to the straight-ahead position.

- ▶ Drive forwards and reverse as prompted by the PARKTRONIC warning displays, several times if necessary.

- ▶ **Vehicles with manual transmission:** stop, at the latest when PARKTRONIC sounds the continuous warning tone.

Once you have exited the parking space completely, the steering wheel is moved to the straight-ahead position. You hear a tone and the **Park Assist switched off** message appears in the multifunction display. You will then have to steer and merge into traffic on your own. PARKTRONIC is still available. You can take over the steering before the vehicle has exited the parking space completely. This is useful, for example when you recognise that it is already possible to pull out of the parking space.

Cancelling Active Parking Assist

You can cancel Active Parking Assist at any time.

- ▶ Stop the movement of the multifunction steering wheel or steer yourself. Active Parking Assist will be cancelled at once. The **Park Assist cancelled** message appears in the multifunction display.

or

- ▶ Press the PARKTRONIC button on the centre console (▷ page 230). PARKTRONIC is switched off and Active Parking Assist is immediately cancelled. The **Park Assist cancelled** message appears in the multifunction display.

Active Parking Assist is cancelled automatically if:

- the transmission is shifted too early
- transmission position **P** is selected
- parking using Active Parking Assist is no longer possible
- you are driving faster than 10 km/h
- a wheel spins and ESP® intervenes or fails. In such cases the  warning lamp lights up in the instrument cluster.

A warning tone sounds. The parking symbol disappears and the multifunction display shows the **Park Assist cancelled** message.

When Active Parking Assist is cancelled, you must steer and brake again yourself.

Vehicles with automatic transmission: if a system malfunction occurs, the vehicle is braked to a standstill. To drive on, depress the accelerator again.

Towing a trailer

For vehicles with a trailer tow hitch, the minimum length for parking spaces is slightly increased.

If you have attached a trailer to your vehicle, you should not use Active Parking Assist. Once the electrical connection is established between your vehicle and the trailer, Active Parking Assist is no longer available. PARKTRONIC is deactivated for the rear area.

Reversing camera

General notes

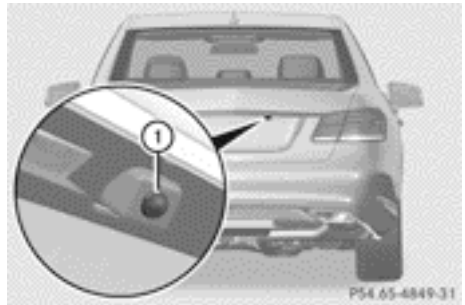

Example: Saloon

Reversing camera ① is located in the boot lid handle.

Reversing camera ① is an optical parking and manoeuvring aid. It shows the area behind your vehicle with guide lines in the COMAND display.

The area behind the vehicle is displayed as a mirror image, as in the rear-view mirror.

- ❗ The text of messages shown in the COMAND display depends on the language setting. The following are examples of reversing camera messages in the COMAND display.

Important safety notes

The reversing camera is only an aid. It is not a substitute for your attention to the immediate surroundings. The responsibility for safe manoeuvring and parking remains with you. Make sure that there are no persons, animals or objects in range while manoeuvring and parking.

Under the following circumstances, the reversing camera will not function, or will function in a limited manner:

- if the boot lid/tailgate is open
- in heavy rain, snow or fog
- at night or in very dark places
- if the camera is exposed to very bright light

- if the area is lit by fluorescent light or LED lighting (the display may flicker)
- if there is a sudden change in temperature, e.g. when driving into a heated garage in winter
- if the camera lens is dirty or obstructed
- if the rear of your vehicle is damaged. In this case, have the camera position and setting checked at a qualified specialist workshop

The field of vision and other functions of the reversing camera may be restricted due to additional accessories on the rear of the vehicle (e.g. licence plate holder, bicycle rack).

Activating/deactivating the reversing camera



- ▶ **To activate:** make sure that the key is in position **2** in the ignition lock.
- ▶ Make sure that the "Activation by R gear" setting is active in COMAND Online, see the separate COMAND Online operating instructions.
- ▶ Engage reverse gear. The area behind the vehicle is shown with guide lines in the COMAND display.
- ▶ **To change the function mode for vehicles with trailer tow hitch:** using the COMAND controller, select symbol **1** for the "Reverse parking" function or symbol **2** for "Coupling up a trailer" (see the

separate COMAND Online operating instructions).

The symbol of the selected function is highlighted.

To deactivate: the reversing camera deactivates if you shift the transmission to **P** or after driving forwards a short distance.

Displays in the COMAND display

The reversing camera may show a distorted view of obstacles or show them incorrectly or not at all. Obstacles are not shown by the reversing camera in the following locations:

- very close to the rear bumper
- under the rear bumper
- in the area immediately above the tailgate handle

! Objects not at ground level may appear to be further away than they actually are, e.g.:

- the bumper of a parked vehicle
- the drawbar of a trailer
- the ball coupling of a trailer tow hitch
- the rear section of an HGV
- a slanted post

Use the guidelines only for orientation.

Approach objects no further than the bottom-most guideline.

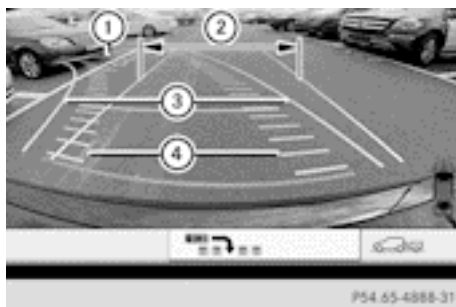

- ① Yellow guide line at a distance of approximately 4.0 m from the rear of the vehicle
- ② White guide line without turning the steering wheel, vehicle width including the exterior mirrors (static)

- ③ Yellow guide line for the vehicle width including the exterior mirrors, for current steering wheel angle (dynamic)
- ④ Yellow lane marking the course the tyres will take at the current steering wheel angle (dynamic)



- ⑤ Yellow guide line at a distance of approximately 1.0 m from the rear of the vehicle
- ⑥ Vehicle centre axle (marker assistance)
- ⑦ Bumper
- ⑧ Red guide line at a distance of approximately 0.30 m from the rear of the vehicle

The guide lines are shown when the transmission is in position **R**.

The distance specifications only apply to objects that are at ground level.

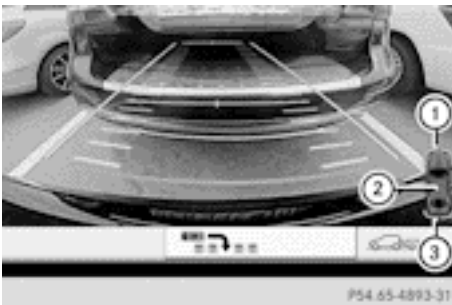

Additional display for vehicles with PARKTRONIC

- ① Front warning display
- ② Additional PARKTRONIC measurement operational readiness indicator
- ③ Rear warning display

Vehicles with PARKTRONIC: when PARKTRONIC is operational (▷ page 228), addi-

tional measurement operational readiness indicator ② appears in the COMAND display. If the PARKTRONIC warning displays are active or light up, warning displays ① and ③ are also active or light up correspondingly in the COMAND display.

"Reverse parking" function

Reversing straight into a parking space without turning the steering wheel



- ① White guide line without turning the steering wheel, vehicle width including the exterior mirrors (static)
- ② Yellow guide line for the vehicle width including the exterior mirrors, for current steering wheel angle (dynamic)
- ③ Yellow guide line at a distance of approximately 1.0 m from the rear of the vehicle
- ④ Red guide line at a distance of approximately 0.30 m from the rear of the vehicle

- ▶ Make sure that the reversing camera is switched on (▷ page 238). The lane and the guide lines are shown.
- ▶ With the help of white guide lines ①, check whether the vehicle will fit into the parking space.
- ▶ Using white guide lines ① as a point of orientation, carefully reverse until you reach the end position. Red guide line ④ is then at the end of the parking space. The vehicle is almost parallel in the parking space.

Reverse perpendicular parking with the steering wheel at an angle



- ① Parking space marking
- ② Yellow guide line for the vehicle width including the exterior mirrors, for current steering wheel angle (dynamic)

- ▶ Make sure that the reversing camera is switched on (> page 238). The lane and the guide lines are shown.
- ▶ Drive past the parking space and bring the vehicle to a standstill.
- ▶ While the vehicle is at a standstill, turn the steering wheel in the direction of the parking space until yellow guide line ② reaches parking space marking ①.
- ▶ Keep the steering wheel in that position and reverse carefully.



Reversing with the steering wheel turned

- ① Yellow guide line for the vehicle width including the exterior mirrors, for current steering wheel angle (dynamic)

- ▶ Stop the vehicle when it is almost exactly in front of the parking space. The white lane should be as close as possible with the parking space marking as possible.



Driving to the final position

- ① White guide line at current steering wheel angle
- ② Parking space marking
- ▶ Turn the steering wheel to the centre position while the vehicle is stationary.

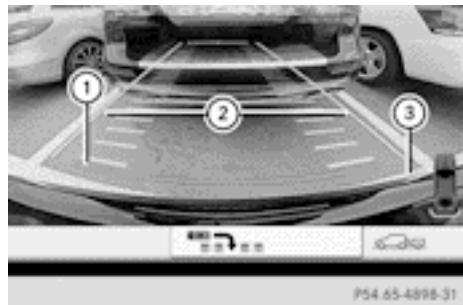

- ① Red guide line at a distance of approximately 0.30 m from the rear of the vehicle
- ② White lane indicating the route the vehicle will take with the steering wheel straight
- ③ End of parking space
- ▶ Reverse carefully until you have reached the end position. Red guide line ① is then at end of parking space ③. The vehicle is almost parallel in the parking space.

"Coupling up a trailer" function

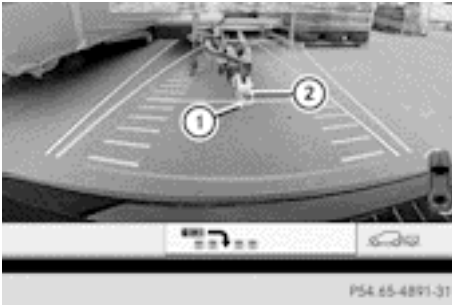

- ① Vehicle centre point on the yellow guide line at a distance of approximately 1.0 m from the rear of the vehicle
- ② Trailer drawbar

This function is only available on vehicles with a trailer tow hitch.

- ▶ Set the height of trailer drawbar ② so that it is slightly higher than the ball coupling.
- ▶ Position the vehicle centrally in front of trailer drawbar ②.



- ① Red guide line at a distance of approximately 0.30 m from the ball coupling
 - ② Trailer drawbar locating aid
 - ③ Trailer drawbar
 - ④ Symbol for the "Coupling up a trailer" function
- ▶ Use the COMAND controller to select symbol ④, see the separate operating instructions for COMAND Online. The "Coupling up a trailer" function is selected. The distance specifications now only

apply to objects that are at the same level as the ball coupling.

- ▶ Reverse carefully, making sure trailer drawbar locating aid ② points approximately in the direction of the trailer drawbar.
- ▶ Reverse carefully until trailer drawbar ③ reaches red guide line ①. The distance between the trailer drawbar and the red guide line is now approximately 0.30 m.
- ▶ Couple up the trailer (▷ page 263).

360° camera

General notes

The 360° camera is a camera system that consists of four cameras.

The system evaluates images from the following cameras:

- Reversing camera
- Front camera
- Two cameras in the exterior mirrors

The cameras cover the immediate surroundings of the vehicle. The system assists you, for instance when parking or at exits with reduced visibility.

You can show pictures from the 360° camera in full-screen mode or in seven different split-screen views on the COMAND display. A split-screen view also includes a top view of the vehicle. This view is calculated from the data supplied by the installed cameras (virtual camera).

The seven split-screen views are:

- top view and image from the reversing camera (130° viewing angle)
- top view and image from the front camera (130° viewing angle without displaying the maximum steering wheel angle)
- top view and enlarged rear view
- top view and enlarged front view
- top view and trailer view (vehicles with trailer tow hitch)

- top view and images from the rear-facing mirror cameras (rear wheel view)
 - top view and images from the forward facing mirror cameras (front wheel view)
- i** The top view and trailer view are available for vehicles equipped with a trailer tow hitch.

When the function is active and you shift the transmission from **D** or **R** to **N**, the dynamic guidelines are hidden.

When you change between transmission positions **D** and **R**, you see the previously selected front or rear view.

Important safety notes

The 360° camera is only an aid and may show a distorted view of obstacles, show them incorrectly or not at all. The 360° camera is not a substitute for attentive driving.

The responsibility for safe manoeuvring and parking remains with you. Make sure that there are no persons, animals or objects in range while manoeuvring and parking.

You are always responsible for safety, and must always pay attention to your surroundings when parking and manoeuvring. This applies to the areas behind, in front of and beside the vehicle. You could otherwise endanger yourself and others.

The 360° camera will not function or will function only in a limited manner:

- if the doors are open
- if the exterior mirrors are folded in
- if the boot lid is open
- in heavy rain, snow or fog
- at night or in very dark places
- if the cameras are exposed to very bright light
- if the area is lit by fluorescent light or LED lighting (the display may flicker)
- if you drive into a heated garage in the winter and the temperature changes very quickly

- if the camera lenses are dirty or covered
- if the vehicle components in which the cameras are fitted are damaged. In this event, have the camera position and setting checked at a qualified specialist workshop.

Do not use the 360° camera in this case. You could otherwise injure others or damage objects when parking the vehicle.

Guide lines are always shown at road level. In trailer mode, the guide lines are shown at the level of the trailer coupling.

Activation conditions

The 360° camera image can be displayed if:

- your vehicle is equipped with a 360° camera
- the key is in position **2** in the ignition lock
- COMAND Online is switched on; see the separate COMAND Online operating instructions
- the **360° camera** function is activated

Activating the 360° camera using the SYS button

- ▶ Press the **[SYS]** button for longer than 2 seconds; see the separate COMAND Online operating instructions.

The following appears depending on whether transmission position **D** or **R** is selected:

- full-screen view with image from the front camera
- full-screen view with image from the reversing camera

Activating the 360° camera using COMAND Online

- ▶ Press the **[SYS]** button; see the separate COMAND Online operating instructions.

or

- ▶ Select **System** by turning **[⊙]** the COMAND controller and press **[↻]** to confirm.

- ▶ Select **360° camera** and press  to confirm.

The following appears depending on whether transmission position **D** or **R** is selected:

- a split-screen with top view and the image from the front camera or
- a split-screen with top view and the image from the reversing camera

For further information on the COMAND controller; see the separate COMAND Online operating instructions.

Activating the 360° camera using reverse gear





You can show images from the 360° camera automatically by engaging reverse gear.

- ▶ Make sure that the key is in position **2** in the ignition lock.
- ▶ Make sure that the **Activation by R gear** setting is active in COMAND Online, see the separate COMAND Online operating instructions.

- ▶ **To show the 360° camera image:** engage reverse gear.

The area behind the vehicle is shown in the COMAND display in split-screen mode. You see the top view of the vehicle and the image from the reversing camera.

Selecting the split-screen and full screen displays

- ▶ **To switch between split screen views:** switch to the line with the vehicle icons by sliding  the COMAND controller.
- ▶ Turn  the COMAND controller and select one of the vehicle icons.
- ▶ **To switch to full screen mode:** select **Full screen** by turning  the COMAND controller and press  to confirm.

-  The full screen option is only available in the following views:

- top view with image from the reversing camera
- top view with image from the front camera

Displays in the COMAND display

Important safety notes

The camera system may show a distorted view of obstacles or show them incorrectly or not at all. Obstacles are not shown by the system in the following locations:

- under the front and rear bumpers
- very close to the front and rear bumpers
- in the area immediately above the tailgate handle/boot lid handle
- very close to the exterior mirrors
- in the transitional areas between the various cameras in the virtual top view

-  Objects not at ground level may appear to be further away than they actually are, e.g.:

- the bumper of a parked vehicle
- the drawbar of a trailer
- the ball coupling of a trailer tow hitch
- the rear section of an HGV
- a slanted post

Use the guidelines only for orientation. Approach objects no further than the bottom-most guideline.

Top view with image from the reversing camera

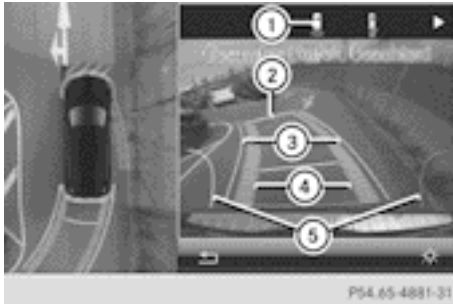

- ① Symbol for the split screen setting with top view and reversing camera image
- ② Yellow guide line at a distance of approximately 4.0 m from the rear of the vehicle
- ③ Yellow guide line for the vehicle width including the exterior mirrors, for current steering wheel angle (dynamic)
- ④ Yellow lane marking the course the tyres will take at the current steering wheel angle (dynamic)
- ⑤ Yellow guide line for the maximum steering angle

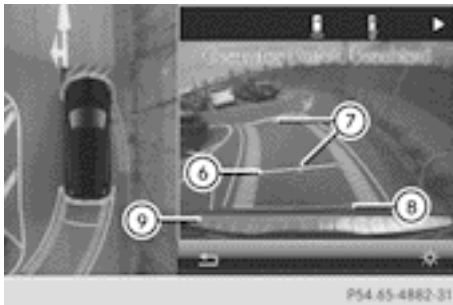

- ⑥ Yellow guide line at a distance of approximately 1.0 m from the rear of the vehicle
- ⑦ Vehicle centre axle (marker assistance)
- ⑧ Red guide line at a distance of approximately 0.30 m from the rear of the vehicle
- ⑨ Bumper

The guide lines are shown when the transmission is in position **R**.

The distance specifications only apply to objects that are at ground level.

Top view with image from the front camera

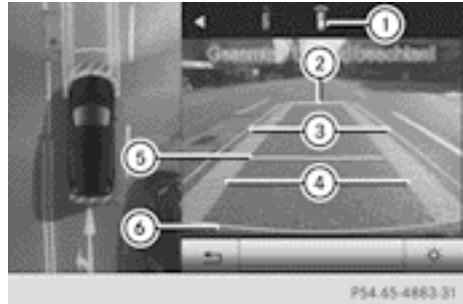

- ① Symbol for the split screen setting with top view and front camera image
- ② Yellow guide line at a distance of approximately 4.0 m from the front of the vehicle
- ③ Yellow guide line for the vehicle width including the exterior mirrors, for current steering wheel angle (dynamic)
- ④ Yellow lane marking the course the tyres will take at the current steering wheel angle (dynamic)
- ⑤ Yellow guide line at a distance of approximately 1.0 m from the front of the vehicle
- ⑥ Red guide line at a distance of approximately 0.30 m from the front of the vehicle

Top view and enlarged rear view

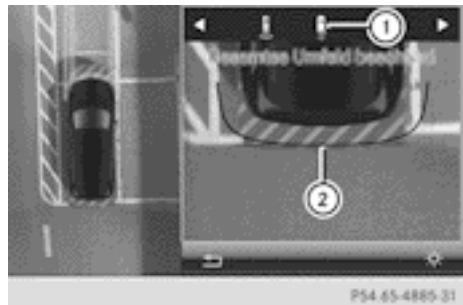

- ① Symbol for the split screen setting with top view and reversing camera image enlarged
- ② Red guide line at a distance of approximately 0.30 m from the rear of the vehicle

This view assists you in estimating the distance to the vehicle behind you.

- ① This setting can also be selected as an enlarged front view.

Top view with image from the mirror cameras

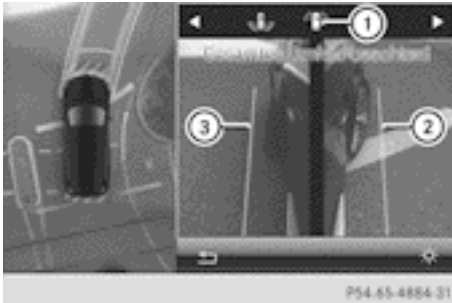

- ① Symbol for the top view and forward-facing mirror camera setting
- ② Yellow guide line for the vehicle width including the exterior mirror (right side of vehicle)
- ③ Yellow guide line for the vehicle width including the exterior mirror (left side of vehicle)

- ① You can also select the mirror camera setting for the rear-facing view.

Top view with trailer view

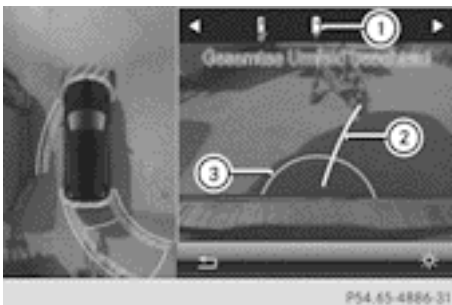

- ① Symbol for the trailer view setting
- ② Trailer drawbar locating aid
- ③ Red guide line at a distance of approximately 0.30 m from the ball coupling

The lines are shown at the level of the trailer coupling.

Wide-angle function



Example: full-screen view with PARKTRONIC display

- ① Symbol for the full-screen setting with the reversing camera image
- ② PARKTRONIC warning display

If the vehicle is equipped with PARKTRONIC and the function is activated (▷ page 230), warning displays ② in the COMAND display are also active or light up accordingly.

PARKTRONIC appears as follows:

- as red or yellow brackets around the vehicle symbol in top view in split-screen mode or
- at the bottom right as red or yellow brackets around the vehicle symbol in full-screen mode

- ① Full-screen mode can also be selected as front view.

Select this view when you are driving out of an exit and the view of crossing traffic is restricted, for example.



Object detection



- ① Symbol for the full-screen setting with the reversing camera image
- ② Bar for marking a detected object

In full screen mode, the 360° camera can detect both moving and stationary objects. If, for example, a pedestrian or another vehicle is detected, these objects are marked with bar ②. The system is only able to detect and mark stationary objects when your vehicle is moving. By contrast, moving objects will always be detected and marked.

Stopping the 360° camera display

As soon as the vehicle exceeds a speed of 30 km/h with the function activated, the function switches off. The previous display appears on the COMAND display. You can also switch the display by selecting the  symbol in the display and pressing  the COMAND controller to confirm.

The 360° camera display is also ended if you select transmission position **P**.

ATTENTION ASSIST

General notes

ATTENTION ASSIST helps you during long, monotonous journeys such as on motorways and trunk roads. It is active in the 60 km/h to 200 km/h range. If ATTENTION ASSIST detects typical indicators of fatigue or increasing lapses in concentration on the part of the driver, it suggests taking a break.

Important safety notes

ATTENTION ASSIST is only an aid. It may detect fatigue or lapses in concentration too late or not at all. The system is not a substitute for a well-rested and attentive driver.

The functionality of ATTENTION ASSIST is restricted, and warnings may be delayed or not occur at all:

- if the length of the journey is less than approximately 30 minutes
- if the road condition is poor, e.g. if the surface is uneven or if there are potholes
- if there is a strong side wind
- if you have adopted a sporty driving style with high cornering speeds or high rates of acceleration
- if you are predominantly driving at a speed below 60 km/h or above 200 km/h
- if you are driving with the DISTRONIC PLUS active steer assist activated
- if the time has been set incorrectly
- in active driving situations, such as when you change lanes or change your speed

ATTENTION ASSIST is reset and starts assessing your tiredness again when you continue your journey if:

- you switch off the engine
- you take off your seat belt and open the driver's door, e.g. for a change of drivers or to take a break

Displaying the attention level



You can have current status information displayed in the assistance menu (▷ page 277) of the on-board computer.

- ▶ Select the assistance graphics display for ATTENTION ASSIST using the on-board computer (▷ page 277).

The following information is displayed:

- the length of the journey since the last break
- the attention level determined by ATTENTION ASSIST, displayed in a bar display in five levels from high to low
- If ATTENTION ASSIST is unable to calculate the attention level and a warning cannot be issued, the **System suspended** message appears. The bar display then changes the display, e.g. if you are driving at a speed below 60 km/h or above 200 km/h.

Activating ATTENTION ASSIST

- ▶ Activate ATTENTION ASSIST using the on-board computer (▷ page 279). The system determines the attention level of the driver depending on the setting selected:

Standard selected: the sensitivity with which the system determines the attention level is set to normal.

Sensitive selected: the sensitivity is set higher. The attention level detected by ATTENTION ASSIST is adapted accordingly and the driver is warned earlier.

When ATTENTION ASSIST is deactivated, the  symbol and OFF appear in the multifunction display in the assistance graphics display when the engine is running.

When ATTENTION ASSIST has been deactivated, it is automatically reactivated after the engine has been stopped. The sensitivity selected corresponds to the last selection activated (standard/sensitive).

Warning in the multifunction display

If fatigue or increasing lapses in concentration are detected, a warning appears in the multifunction display: **Attention Assist: Take a break!**

In addition to the message shown in the multifunction display, you will then hear a warning tone.

- ▶ If necessary, take a break.
- ▶ Confirm the message by pressing the  button on the steering wheel.

On long journeys, take regular breaks in good time to allow yourself to rest properly. If you do not take a break and ATTENTION ASSIST still detects increasing lapses in concentration, you will be warned again after 15 minutes at the earliest. This will only happen if ATTENTION ASSIST still detects typical indicators of fatigue or increasing lapses in concentration.

Traffic Sign Assist

General notes

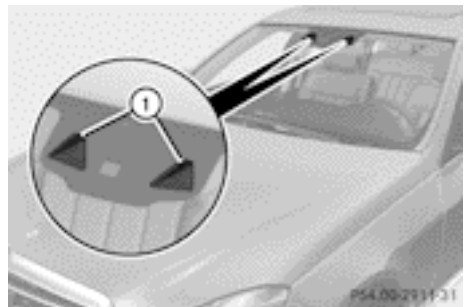

Traffic Sign Assist displays the maximum speed permitted and overtaking restrictions to the driver in the instrument cluster. Driving onto a section of road in the wrong direction triggers a warning. Traffic Sign Assist detects traffic signs with camera system ① attached behind the top of the windscreen. The data and general traffic regulations stored in the navigation system are also used to determine the current speed limit.

If a traffic sign that is relevant to your vehicle is passed, the display of the speed limits and overtaking restrictions is updated.

The display can also be updated without a visible traffic sign if:

- the vehicle changes roads (e.g. motorway exit or slip road)
- a village or town boundary is passed which is stored in the digital map
- the last traffic sign detected by the camera has not been repeated

If a sign indicating the end of a restriction (speed limit or overtaking restriction) is passed, the sign is displayed for five seconds. The applicable traffic regulation then appears in the instrument cluster.

The camera also detects traffic signs with a restriction indicated by an additional sign (e.g. in wet conditions).

The traffic signs are only displayed with the restrictions if:

- the regulation must be observed with the restriction, or
- Traffic Sign Assist is unable to determine whether the restriction applies

If Traffic Sign Assist is unable to determine a maximum permitted speed from any of the available sources, no speed limit is displayed in the instrument cluster either.

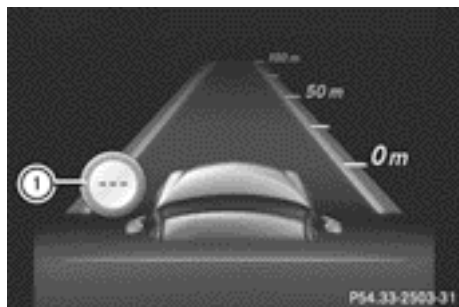

Traffic Sign Assist is not available in all countries. In this case, symbol ① is shown in the assistance graphic display (▷ page 277).

Important safety notes

Traffic Sign Assist is only an aid and is not always able to correctly display speed limits and overtaking restrictions. Traffic signs always have priority over the Traffic Sign Assist display.

The system may be either functionally impaired or temporarily unavailable if:

- visibility is poor, e.g. due to snow, rain, fog or spray
- there is glare, e.g. from the sun being low in the sky
- there is dirt, ice or misting on the wind-screen in the area of the camera
- traffic signs are hard to detect (dirt, ice, snow)
- there is insufficient illumination of the traffic signs in the night
- signs are ambiguous (e.g. traffic signs on construction sites or in adjacent lanes)
- the information in the digital street map of the navigation system is incorrect or out of date

Switching the message function on/off

The Traffic Sign Assist message function can be switched on in the on-board computer. When you pass a traffic sign, traffic regulations (speed limits and overtaking restrictions) are shown in the multifunction display for five seconds. The previous menu is then shown automatically.

The wrong-way warning remains active even if the message function has been deactivated.

- ▶ Switch on the Traffic Sign Assist message function via the on-board computer (▷ page 278).

Instrument cluster display

Showing the assistance graphic

- ▶ Call up the assistance graphics display function using the on-board computer (> page 277).
- ▶ Select the Traffic Sign Assist display. Detected traffic signs are displayed in the instrument cluster.

Speed limit with overtaking restriction

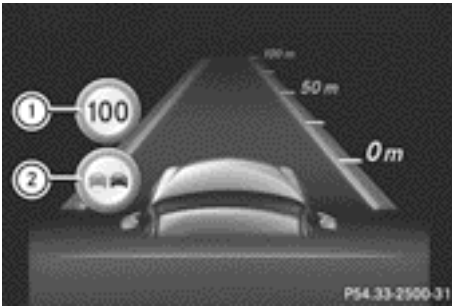

A maximum permitted speed of 100 km/h (100 mph) ① and an overtaking restriction ② apply.

Speed limit with unknown restriction

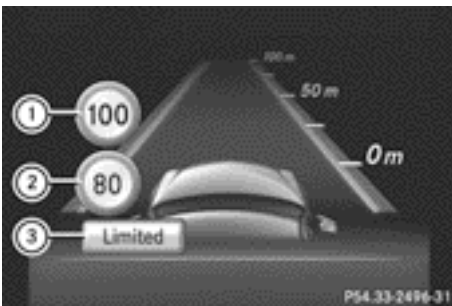

- ① Maximum permitted speed
- ② Maximum permitted speed for vehicles for which the restriction in the additional sign is relevant
- ③ Additional sign for unknown restriction

A maximum permitted speed of 100 km/h (100 mph) and a speed limit of 80 km/h (80 mph) apply with an unknown restriction.

Speed limits in wet conditions

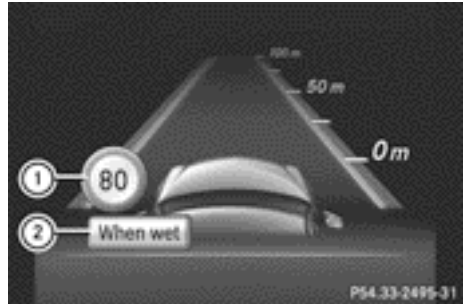

- ① Maximum permitted speed
- ② Additional signs for wet conditions

A maximum permitted speed of 80 km/h (80 mph) applies in wet conditions and when Traffic Sign Assist has determined that the restriction must be observed.

Cancelling the overtaking restriction

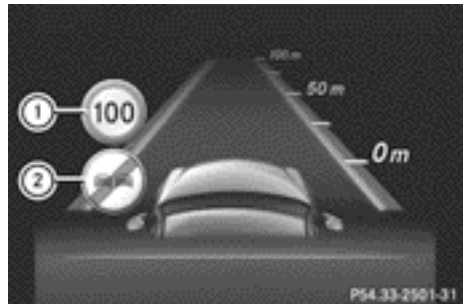

A maximum permitted speed of 100 km/h (100 mph) ① applies. The overtaking restriction no longer applies ②. The crossed-out no overtaking traffic sign is displayed for five seconds.

End of a speed limit

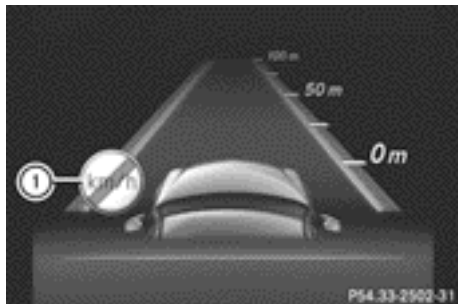

The speed limit no longer applies ①.

- i** The unit for the speed limit (km/h or mph) depends on the country in which you are driving. It is generally neither shown on the traffic sign nor on the instrument cluster but must be taken into account when observing the maximum permitted speed.

No entry (wrong-way warning)



If a no entry sign or roundabout sign is passed, warning message ① is displayed in the instrument cluster if Traffic Sign Assist detects that the vehicle is travelling in the wrong direction. You will then also hear a warning tone. You should immediately check your direction of travel in order to avoid danger to yourself and other road users.

- i** This function is not available in all countries.

Lane Tracking package

General notes

The Lane Tracking package consists of Blind Spot Assist (▷ page 250) and Lane Keeping Assist (▷ page 252).

Blind Spot Assist

General notes

Blind Spot Assist uses a radar sensor system to monitor the areas on both sides of your vehicle. It supports you from speeds of 30 km/h. A warning display in the exterior mirrors draws your attention to vehicles detected in the monitored area. If you then switch on the corresponding turn signal to change lane, you will also receive an optical and audible collision warning. For monitoring, Blind Spot Assist uses sensors in the rear bumper.

Important safety notes

⚠ WARNING

Blind Spot Assist does not react to vehicles:

- overtaken too closely on the side, placing them in the blind spot area
- when the difference in the speed of approach and overtaking is too great

As a result, Blind Spot Assist cannot warn drivers in these situations. There is a risk of an accident.

Always pay careful attention to the traffic situation and maintain a safe distance at the side of the vehicle.

Blind Spot Assist is only an aid. It may fail to detect some vehicles and is no substitute for attentive driving. Always ensure that there is sufficient distance to the side for other road users and obstacles.

Monitoring range of the sensors

In particular, the detection of obstacles can be impaired in the case of:

- dirt on the sensors or the sensors are obscured
- poor visibility, e.g. due to fog, heavy rain, snow or spray
- narrow vehicles, e.g. motorcycles or bicycles
- very wide lanes
- narrow lanes
- vehicles not driving in the middle of their lane
- barriers or other road boundaries

Vehicles in the monitoring range are then not indicated.

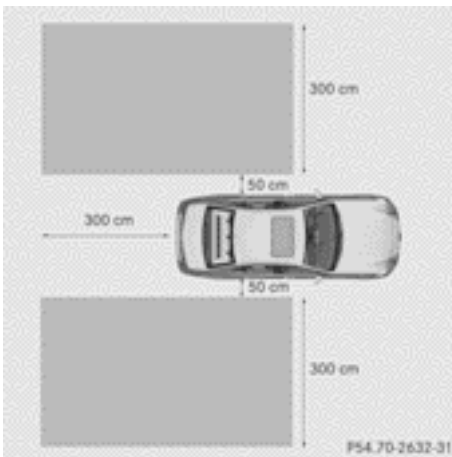

Example: Saloon

Blind Spot Assist monitors the area up to 3.0 m behind your vehicle and directly next to your vehicle, as shown in the diagram.

If the lanes are narrow, vehicles driving in the lane beyond the lane next to your vehicle may be indicated, especially if the vehicles are not driving in the middle of their lane. This may be the case if there are vehicles at the edge of their lane nearest your vehicle.

Due to the nature of the system:

- warnings may be issued in error when driving close to crash barriers or similar solid lane borders.
- warnings may be interrupted when driving alongside long vehicles, for example lorries, for a prolonged time.

The two radar sensors for Blind Spot Assist are integrated into the sides of the rear bumper. Make sure that the bumper is free of dirt, ice or slush in the vicinity of the sensors. The sensors must not be covered, for example by cycle racks or overhanging loads. Following a severe impact or in the event of damage to the bumpers, have the function of the sensors checked at a qualified specialist workshop. Blind Spot Assist may otherwise not work properly.

Indicator and warning display

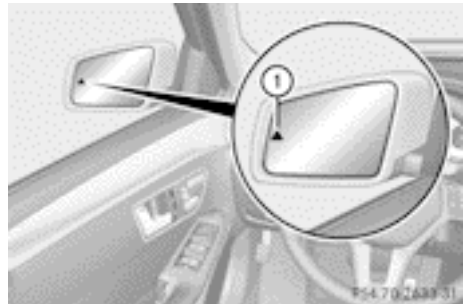

① Yellow indicator lamp/red warning lamp

Blind Spot Assist is not active at speeds below approximately 30 km/h. Vehicles in the monitoring range are then not indicated.

If Blind Spot Assist is activated, indicator lamp ① in the exterior mirrors lights up yellow up to a speed of 30 km/h. At speeds above 30 km/h, the indicator lamp goes out and Blind Spot Assist is operational.

If a vehicle is detected within the monitoring range of Blind Spot Assist at speeds above 30 km/h, warning lamp ① on the corresponding side lights up red. This warning always occurs when a vehicle enters the blind spot monitoring range from behind or from

the side. When you overtake a vehicle, the warning only occurs if the difference in speed is less than 12 km/h.

The yellow indicator lamp goes out if reverse gear is engaged. Blind Spot Assist is then deactivated.

The brightness of the indicator/warning lamps is adjusted automatically according to the ambient light.

Collision warning

If a vehicle is detected in the monitoring range of Blind Spot Assist and you switch on the corresponding turn signal, a double warning tone sounds. Red warning lamp ① flashes. If the turn signal remains on, detected vehicles are indicated by the flashing of red warning lamp ①. There are no further warning tones.

Activating Blind Spot Assist

- ▶ Make sure that Blind Spot Assist (> page 279) is activated in the on-board computer.
- ▶ Turn the key to position **2** in the ignition lock.
Warning lamps ① in the exterior mirrors light up red for approximately 1.5 seconds and then turn yellow.

Towing a trailer

If you attach a trailer, make sure that you have correctly established the electrical connection. This can be accomplished by checking the trailer lighting. Blind Spot Assist is then deactivated. The indicator lamp lights up yellow in the exterior mirrors and the **Blind Spot Assist currently unavailable** See Owner's Manual message appears in the multifunction display.

i You can deactivate the indicator lamps in the exterior mirrors.

To do so, deactivate Blind Spot Assist if:

- the key is in position **2** in the ignition lock
- the engine is not running
- the electrical connection to the trailer has been established.

Lane Keeping Assist

General notes

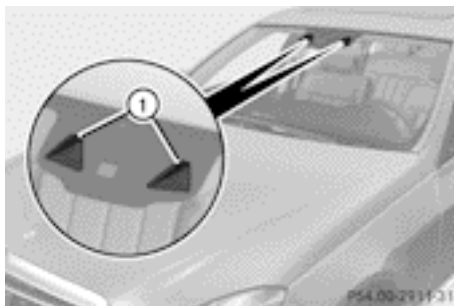

Lane Keeping Assist monitors the area in front of your vehicle by means of a camera ①, at the top of the windscreen. Active Lane Keeping Assist detects lane markings on the road and can warn you before you leave your lane unintentionally.

This function is available in the range between 60 km/h and 200 km/h.

A warning may be given if a front wheel passes over a lane marking. It will warn you by means of intermittent vibration in the steering wheel for up to 1.5 seconds.

Important safety notes

⚠ WARNING

Lane Keeping Assist cannot always clearly identify lane markings.

In these cases, Lane Keeping Assist may:

- give an unnecessary warning
- not give a warning

There is a risk of an accident.

Always pay particular attention to the traffic situation and keep in lane, especially if Lane Keeping Assist alerts you.

⚠ WARNING

The Lane Keeping Assist warning does not return the vehicle to the original lane. There is a risk of an accident.

Always steer, apply the brakes or accelerate the vehicle yourself, especially if Lane Keeping Assist alerts you.

If you fail to adapt your driving style, Lane Keeping Assist can neither reduce the risk of an accident nor override the laws of physics. Lane Keeping Assist cannot take into account road, weather or traffic conditions. Lane Keeping Assist is only an aid. You are responsible for the distance to the vehicle in front, for vehicle speed, for braking in good time, and for staying in the lane.

Lane Keeping Assist does not keep your vehicle in its lane.

The system may be impaired or may not function if:

- there is poor visibility, e.g. due to insufficient illumination of the road, or due to snow, rain, fog or spray
- there is glare, e.g. from oncoming traffic, the sun or reflection from other vehicles (e.g. if the road surface is wet)
- the windscreen is dirty, misted up, damaged or covered, for instance by a sticker, in the vicinity of the camera
- no lane markings or several unclear lane markings are present for one lane, e.g. in a construction area
- the lane markings are worn away, dark or covered up, e.g. by dirt or snow
- the distance to the vehicle in front is too small and the lane markings thus cannot be detected
- the lane markings change quickly, e.g. lanes branch off, cross one another or merge
- the road is narrow and winding
- there are highly variable shade conditions on the road

Activating Lane Keeping Assist

► Activate Lane Keeping Assist using the on-board computer; to do so, select **Standard** or **Adaptive** (> page 279).

If you drive at speeds above 60 km/h and lane markings are detected, the lines in the assistance graphics display (> page 277) are shown in green. Lane Keeping Assist is ready for use.

Standard

If **Standard** is selected, no warning vibration occurs if:

- you have switched on the turn signals. In this case, the warnings are suppressed for a certain period of time.
- a driving safety system intervenes, such as ABS, BAS or ESP®.

Adaptive

When **Adaptive** is selected, no warning vibration occurs if:

- you have switched on the turn signals. In this case, the warnings are suppressed for a certain period of time.
- a driving safety system intervenes, such as ABS, BAS or ESP®.
- you accelerate hard, e.g. kickdown.
- you brake hard.
- you steer actively, e.g. swerve to avoid an obstacle or change lane quickly.
- you cut the corner on a sharp bend.

In order that you are warned only when necessary and in good time if you cross the lane marking, the system recognises certain conditions and warns you accordingly.

The warning vibration occurs earlier if:

- you approach the outer lane marking on a bend.
- the road has very wide lanes, e.g. a motorway.
- the system recognises solid lane markings.

The warning vibration occurs later if:

- the road has narrow lanes.
- you cut the corner on a bend.

Active Driving Assistance package

General notes

The Active Driving Assistance package consists of DISTRONIC PLUS (▷ page 211), Active Blind Spot Assist (▷ page 254) and Active Lane Keeping Assist (▷ page 256).

Active Blind Spot Assist

General notes

Active Blind Spot Assist monitors the areas on either side of the vehicle that are not visible to the driver with two lateral, rear-facing radar sensors. A warning display in the exterior mirrors draws your attention to vehicles detected in the monitored area. If you then switch on the corresponding turn signal to change lanes, you will also receive a visual and audible collision warning. If a risk of side impact is detected, corrective braking may help you avoid a collision. Active Blind Spot Assist evaluates the free space in the direction of travel and to the side before making a course-correcting brake application. For this, Active Blind Spot Assist uses the forward-facing radar sensors.

Active Blind Spot Assist supports you from a speed of approximately 30 km/h.

Important safety notes

Active Blind Spot Assist is only an aid and is not a substitute for attentive driving.

WARNING

Active Blind Spot Assist does not react to vehicles:

- overtaking too closely on the side, placing them in the blind spot area
- if the difference in the speed of approach and overtaking is too great

As a result, Active Blind Spot Assist may neither give warnings nor intervene in such situations. There is a risk of an accident.

Always pay careful attention to the traffic situation and maintain a safe distance at the side of the vehicle.

Radar sensors

The Active Blind Spot Assist radar sensors are integrated into the front and rear bumpers and behind a cover in the radiator grille. Make sure that the bumpers and the cover in the radiator grille are free of dirt, ice or slush. The rear sensors must not be covered, e.g. by bicycle racks or overhanging loads. Following a severe impact or in the event of damage to the bumpers, have the function of the radar sensors checked at a qualified specialist workshop. Active Blind Spot Assist may otherwise no longer function properly.

Monitoring range

WARNING

Active Blind Spot Assist does not detect all traffic situations and road users. There is a risk of an accident.

Always make sure that there is sufficient distance to the side for other traffic or obstacles.

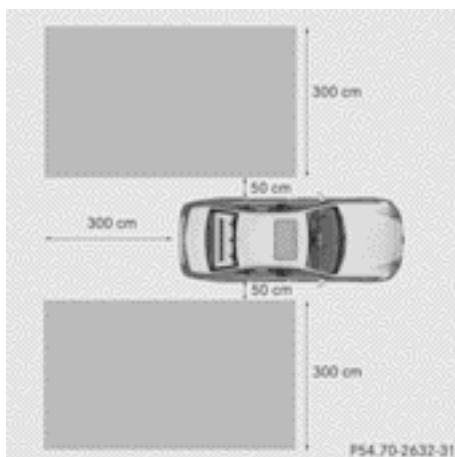

Example: Saloon

Active Blind Spot Assist monitors the area up to 3.0 m behind your vehicle and directly next to your vehicle, as shown in the diagram.

The detection of vehicles may be impaired in the case of:

- dirt on the sensors or the sensors are obscured
- poor visibility, e.g. due to rain, snow or spray

Vehicles in the monitoring range will then be indicated late or not at all.

Active Blind Spot Assist may not detect narrow vehicles, such as motorcycles or bicycles, or may only detect them too late.

If the lanes are narrow, vehicles driving in the lane beyond the lane next to your vehicle may be indicated, especially if the vehicles are not driving in the middle of their lane. This may be the case if there are vehicles at the edge of their lane.

Due to the nature of the system:

- warnings may be issued in error when driving close to crash barriers or similar solid lane borders
- warnings may be interrupted when driving alongside long vehicles, for example lorries, for a prolonged time.

Indicator and warning display

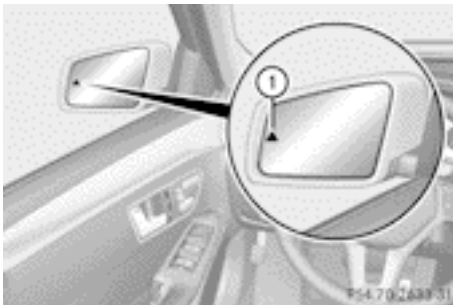

① Yellow indicator lamp/red warning lamp

Active Blind Spot Assist is not active at speeds below approximately 30 km/h. Vehicles in the monitoring range are then not indicated.

If Active Blind Spot Assist is switched on, indicator lamp ① in the exterior mirrors lights up yellow up to a speed of 30 km/h. At speeds above 30 km/h, the indicator lamp goes out and Active Blind Spot Assist is operational.

If a vehicle is detected within the monitoring range of Blind Spot Assist at speeds above 30 km/h, warning lamp ① on the corresponding side lights up red. A warning is always issued when a vehicle enters the blind spot monitoring range from behind or from the side. When you overtake a vehicle, the warning only occurs if the difference in speed is less than 12 km/h.

The yellow indicator lamp goes out if reverse gear is engaged. Active Blind Spot Assist is then no longer active.

The brightness of the indicator/warning lamps is adjusted automatically according to the ambient light.

Visual and acoustic collision warning

If you switch on the turn signals to change lanes and a vehicle is detected in the side monitoring range, you receive a visual and acoustic collision warning. You then hear a double warning tone and red warning lamp ① flashes. If the turn signal remains on, detected vehicles are indicated by the flashing of red warning lamp ①. There are no further warning tones.

Course-correcting brake application

WARNING

A course-correcting brake application cannot always prevent a collision. There is a risk of an accident.

Always steer, brake or accelerate yourself, especially if Active Blind Spot Assist warns you or makes a course-correcting brake application. Always maintain a safe distance at the sides.

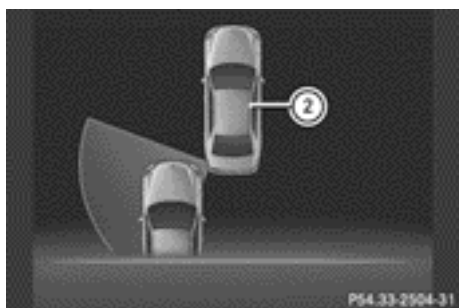
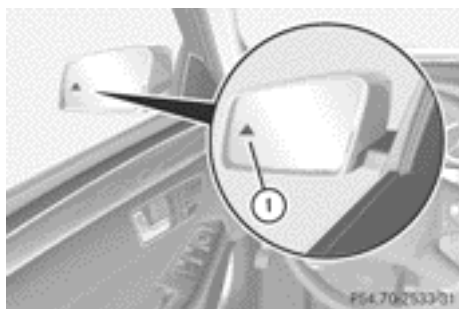

If Active Blind Spot Assist detects a risk of a side impact in the monitoring range, a course-correcting brake application is carried out. This is designed to help you avoid a collision. If a course-correcting brake application occurs, red warning lamp ① flashes in the exterior mirror and a dual warning tone sounds. In addition, display ② appears in the multifunction display.

In very rare cases, the system may make an inappropriate brake application. A course-correcting brake application may be interrupted at any time if you steer slightly in the opposite direction or accelerate.

The course-correcting brake application is available in the speed range between 30 km/h and 200 km/h.

Either a course-correcting brake application appropriate to the driving situation, or none at all, may occur if:

- there are vehicles or obstacles, e.g. crash barriers, on both sides of your vehicle
- a vehicle approaches too closely on the side

- you have adopted a sporty driving style with high cornering speeds
- you brake or accelerate decisively
- a driving safety system intervenes, such as ESP® or PRE-SAFE® Brake
- ESP® is deactivated.
- a loss of tyre pressure or a defective tyre is detected

Activating Active Blind Spot Assist

- ▶ Make sure that Active Blind Spot Assist (▷ page 279) is activated in the on-board computer.
- ▶ Turn the key to position **2** in the ignition lock. Warning lamps ① in the exterior mirrors light up red for approximately 1.5 seconds and then turn yellow.

Towing a trailer

If you attach a trailer, make sure that you have correctly established the electrical connection. This can be accomplished by checking the trailer lighting. Active Blind Spot Assist is then deactivated. The indicator lamp lights up yellow in the exterior mirrors and the **Active Blind Spot Assist currently unavailable** See **Owner's Manual** message appears in the multifunction display.

Active Lane Keeping Assist

General notes

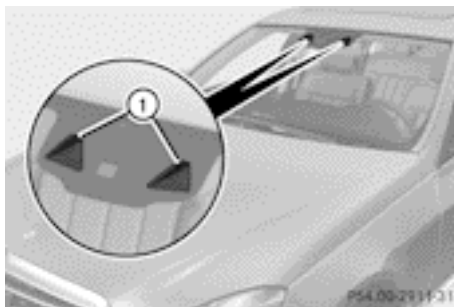

Active Lane Keeping Assist monitors the area in front of your vehicle by means of camera

system ① at the top of the windscreen. Various different areas to the front, rear and side of your vehicle are also monitored with the aid of the radar sensor system. Active Lane Keeping Assist detects lane markings on the road and can warn you before you leave your lane unintentionally. If you do not react to the warning, a lane-correcting application of the brakes can bring the vehicle back into the original lane.

This function is available in the range between 60 km/h and 200 km/h.

For Active Lane Keeping Assist to assist you when driving, the radar sensor system must be operational

Important safety notes

If you fail to adapt your driving style, Active Lane Keeping Assist can neither reduce the risk of an accident nor override the laws of physics. Active Lane Keeping Assist cannot take account of road and weather conditions. It may not recognise traffic situations. Active Lane Keeping Assist is only an aid. You are responsible for the distance to the vehicle in front, for vehicle speed, for braking in good time, and for staying in the lane.

Active Lane Keeping Assist cannot continuously keep your vehicle in its lane.

WARNING

Active Lane Keeping Assist cannot always clearly detect lane markings.

In such cases, Active Lane Keeping Assist can:

- give an unnecessary warning and then make a course-correcting brake application to the vehicle
- neither give a warning nor intervene

There is a risk of an accident.

Always pay particular attention to the traffic situation and keep within the lane, especially if Active Lane Keeping Assist alerts you. Terminate the intervention in a non-critical driving situation.

The system may be impaired or may not function if:

- there is poor visibility, e.g. due to insufficient illumination of the road, or due to snow, rain, fog or spray
- there is glare, e.g. from oncoming traffic, the sun or reflection from other vehicles (e.g. if the road surface is wet)
- the windscreen is dirty, misted up, damaged or covered, for instance by a sticker, in the vicinity of the camera
- if the radar sensors in the front or rear bumpers or the radiator grille are dirty, e.g. obscured by snow
- no, or several, unclear lane markings are present for one lane, e.g. in a construction area
- the lane markings are worn away, dark or covered up, e.g. by dirt or snow
- the distance to the vehicle in front is too small and the lane markings thus cannot be detected
- the lane markings change quickly, e.g. lanes branch off, cross one another or merge
- the road is narrow and winding
- there are highly variable shade conditions on the road

If no vehicle is detected in the adjacent lane and broken lane markings are detected, no lane-correcting brake application is made.

Warning vibration through the steering wheel

A warning may be given if a front wheel passes over a lane marking. It will warn you by means of intermittent vibration in the steering wheel for up to 1.5 seconds.

Lane-correcting brake application

WARNING

A lane-correcting brake application cannot always bring the vehicle back into the original lane. There is a risk of an accident.

Always steer, brake or accelerate yourself, especially if Active Lane Keeping Assist warns you or makes a lane-correcting brake application.

WARNING

Active Lane Keeping Assist only detects traffic conditions or road users to a limited extent. In very rare cases, the system may make an inappropriate brake application, e.g. after intentionally driving over a solid lane marking. There is a risk of an accident.

An inappropriate brake application may be interrupted at any time if you steer slightly in the opposite direction. Always make sure that there is sufficient distance to the side for other traffic or obstacles.

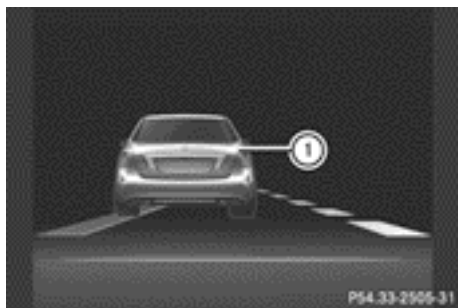

If you leave your lane under certain circumstances, the vehicle will brake briefly on one side. This is intended to help you return the vehicle to the original lane.

If a lane-correcting brake application occurs, display  appears in the multifunction display.

A lane-correcting brake application can be made after driving over a lane marking recognised as being solid or broken. Before this, a warning must have been issued by means of intermittent vibration through the steering wheel. In addition, a lane with lane markings on both sides must be recognised.

In the case of a broken lane marking being detected, a lane-correcting brake application can only be made if a vehicle has been detected in the adjacent lane. The following vehi-

cles can have an influence on brake application: oncoming traffic, vehicles that are overtaking and vehicles that are driving parallel to your vehicle.

 A further lane-correcting brake application can only occur after your vehicle has returned to the original lane.

No lane-correcting brake application occurs if:

- you clearly and actively steer, brake or accelerate.
- you cut the corner on a sharp bend.
- you have adopted a sporty driving style with high cornering speeds or high rates of acceleration.
- you have switched on the turn signals.
- a driving safety system intervenes, such as ESP[®], PRE-SAFE[®] Brake or Active Blind Spot Assist.
- ESP[®] is deactivated.
- the transmission is not in position **D**.
- on vehicles with a trailer tow hitch, the electrical connection to the trailer has been correctly established.
- an obstacle has been detected in the lane in which you are driving.
- a loss of tyre pressure or a defective tyre has been detected and displayed.

There is a possibility that the Active Lane Assistant could misjudge the given traffic situation. An inappropriate brake application may be interrupted at any time if:

- you steer slightly in the opposite direction.
- you switch on the turn signal.
- you clearly brake or accelerate.

A lane-correcting brake application is interrupted automatically if:

- a driving safety system intervenes, such as ESP[®], PRE-SAFE[®] Brake or Active Blind Spot Assist.
- lane markings are no longer be detected.

Activating Active Lane Keeping Assist

► Activate Active Lane Keeping Assist using the on-board computer; to do so, select **Standard** or **Adaptive** (▷ page 279). If you drive at speeds above 60 km/h and lane markings are detected, the lines in the assistance graphics display (▷ page 277) are shown in green. Active Lane Keeping Assist is ready for use.

If **Standard** is selected, no warning vibration occurs if:

- you have switched on the turn signals. In this case, the warnings are suppressed for a certain period of time.
- a driving safety system intervenes, such as ABS, BAS or ESP®.

When **Adaptive** is selected, no warning vibration occurs if:

- you have switched on the turn signals. In this case, the warnings are suppressed for a certain period of time.
- a driving safety system intervenes, such as ABS, BAS or ESP®.
- you accelerate hard, e.g. kickdown.
- you brake hard.
- you steer actively, e.g. swerve to avoid an obstacle or change lane quickly.
- you cut the corner on a sharp bend.

In order that you are warned only when necessary and in good time if you cross the lane marking, the system recognises certain conditions and warns you accordingly.

The warning vibration occurs earlier if:

- you approach the outer lane marking on a bend.
- the road has very wide lanes, e.g. a motorway.
- the system recognises solid lane markings.

The warning vibration occurs later if:

- the road has narrow lanes.
- you cut the corner on a bend.

Towing a trailer

If you attach a trailer, make sure that you have correctly established the electrical connection. This can be accomplished by checking the trailer lighting.

Towing a trailer

Important safety notes

WARNING

The braking system can overheat if you leave your foot on the brake pedal while driving. This increases the braking distance and could even cause the braking system to fail. There is a risk of an accident.

Never use the brake pedal as a footrest. Do not simultaneously depress both the brake pedal and the accelerator pedal while driving.

WARNING

You could lose control of the vehicle/trailer combination if it begins to swerve. The vehicle/trailer combination could even overturn. There is a risk of an accident.

On no account should you attempt to straighten out the vehicle/trailer combination by increasing speed. Decrease your speed and do not countersteer. Brake if necessary.

WARNING

If the maximum permissible load for a carrier system is exceeded, the carrier could come loose from the vehicle and endanger other road users. There is a risk of an accident and injury.

Never exceed the permissible noseweight when using a carrier.

! Depressing the brake pedal constantly results in excessive and premature wear to the brake pads.

If you exceed the maximum permissible nose-weight of the trailer drawbar on the ball coupling, the following may become damaged:

- your vehicle
- the trailer
- the ball coupling
- the trailer tow hitch

The vehicle/trailer combination could become unstable.

If the noseweight used is lower than the minimum permissible noseweight, the vehicle/trailer combination could also become unstable.

To avoid hazardous situations:

- make sure to check the noseweight before each journey.
- use a drawbar noseweight as close as possible to the maximum noseweight.
- do not exceed the maximum permissible noseweight.
- do not use a noseweight lower than the minimum permissible trailer drawbar noseweight.

When reversing the vehicle towards the trailer, make sure there is nobody between the trailer and the vehicle.

Couple and uncouple the trailer carefully. If you do not couple the trailer to the towing vehicle correctly, the trailer could become detached.

Make sure that the following values are not exceeded:

- the permissible trailer drawbar noseweight
- the permissible trailer load
- the permissible rear axle load of the towing vehicle
- the maximum permissible gross vehicle weight of both the towing vehicle and the trailer

You will find the applicable permissible values, which must not be exceeded, in the vehicle documents.

You will find the values approved by the manufacturer on the vehicle identification plates

and those for the towing vehicle under "Technical data" (▷ page 481).

When towing a trailer, your vehicle's handling characteristics will be different in comparison to when driving without a trailer.

The vehicle/trailer combination:

- is heavier
- is restricted in its acceleration and gradient-climbing capability
- has an increased braking distance
- is affected more by strong crosswinds
- demands more sensitive steering
- has a larger turning circle

This can impair the vehicle's handling characteristics. Adapt your style of driving accordingly. Maintain a safe distance. Drive carefully.

When towing a trailer, always adjust your speed to the current road and weather conditions. Do not exceed the maximum permissible speed for your vehicle/trailer combination.

Notes on towing a trailer

General notes

i When towing a trailer, set the tyre pressure on the rear axle of the towing vehicle for a maximum load; see the tyre pressure table in the fuel filler flap (▷ page 407).

Please note that when towing a trailer, PARKTRONIC (▷ page 228), Active Parking Assist (▷ page 232) and Blind Spot Assist (▷ page 250) are only available with limitations, or not at all.

i On vehicles without level control, the height of the ball coupling will alter according to the load placed on the vehicle. If necessary, use a trailer with a height-adjustable drawbar.

You will find fitting dimensions and loads under "Technical data" (▷ page 480).

Driving tips

- ① Observe the notes on ESP® trailer stabilisation (▷ page 80).

The maximum permissible speed for vehicle/trailer combinations depends on the type of trailer. Before beginning the journey, check the trailer's documents to see what the maximum permitted speed is. Observe the legally prescribed maximum speed in the relevant country.

For certain Mercedes-Benz vehicles, the maximum permissible rear axle load is increased when towing a trailer. Refer to the "Technical data" section to find out whether this applies to your vehicle. If you utilise any of the added maximum rear axle load when towing a trailer, the vehicle/trailer combination may not exceed a maximum speed of 100 km/h for reasons concerning the operating permit. This also applies in countries in which the permissible maximum speed for vehicle/trailer combinations is above 100 km/h.

When towing a trailer, your vehicle's handling characteristics will be different in comparison to when driving without a trailer and it will consume more fuel.

Change into a lower gear in good time on long and steep downhill gradients.

- ① This also applies if you have activated cruise control, SPEEDTRONIC or DIS-TRONIC PLUS.

This will use the braking effect of the engine, so less braking will be required to maintain vehicle speed. This relieves the load on the brake system and prevents the brakes from overheating and wearing too quickly. If you need additional braking, depress the brake pedal repeatedly rather than continuously.

Driving tips

If the trailer swings from side to side:

- ▶ Do not accelerate.
- ▶ Do not countersteer.
- ▶ Brake if necessary.

- Maintain a greater distance from the vehicle in front than when driving without a trailer.
- Avoid braking abruptly. If possible, brake gently at first to allow the trailer to run on. Then, increase the braking force rapidly.
- The values given for gradient-climbing capabilities from a standstill refer to sea level. When driving in mountainous areas, note that the power output of the engine, and consequently the vehicle's gradient-climbing capability, decrease with increasing altitude.

Folding out the ball coupling

WARNING

If the ball coupling is not correctly engaged, the trailer can detach. There is a risk of an accident.

Always engage the ball coupling as described.

WARNING

If you release the ball coupling or it does not engage correctly when folding in, it will swing out. Within pivoting range of the ball coupling, there is an increased risk of an accident and injury.

Only release the ball coupling if the pivoting range is unobstructed. Always make sure that the ball coupling engages when folding in.

WARNING

Hybrid vehicles: ensure that you read the "HYBRID" supplement. You could otherwise fail to recognise dangers.

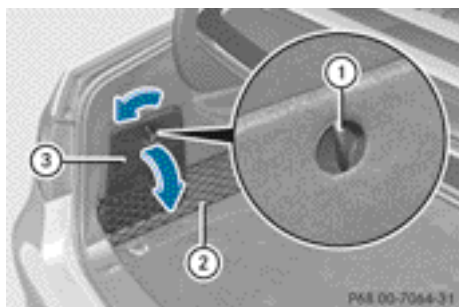

Saloon

Before you can tow a trailer with your vehicle, you must fold out the ball coupling.

The release wheel is located behind the left-hand side trim panel in the boot/luggage compartment.

To open the cover (Saloon):

- ▶ Slide luggage net (2) down.
- ▶ Turn handle (1) anti-clockwise and fold down cover (3).

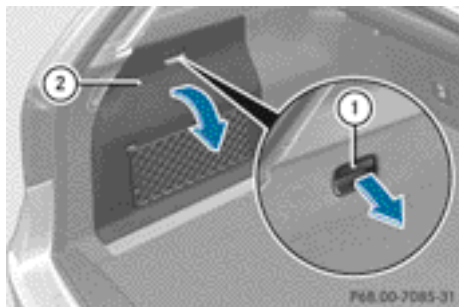

Estate

Before you can tow a trailer with your vehicle, you must fold out the ball coupling.

The release wheel is located behind the left-hand side trim panel in the boot/luggage compartment.

To open the cover (Estate):

- ▶ Pull handle (1) in the direction of the arrow and fold cover (2) down.

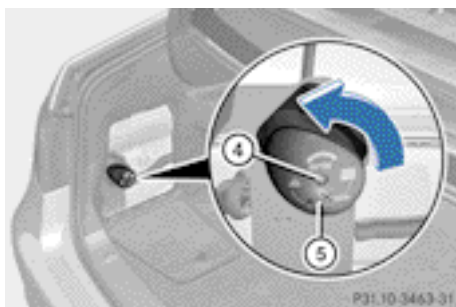

Saloon

To unlock and fold out the ball coupling (Saloon):

- ▶ Grip release wheel (5) so that your thumb lies on the thumb rest.
- ▶ Turn release wheel (5) anti-clockwise until the ball coupling releases and folds out from under the rear bumper. Indicator lamp (4) flashes.

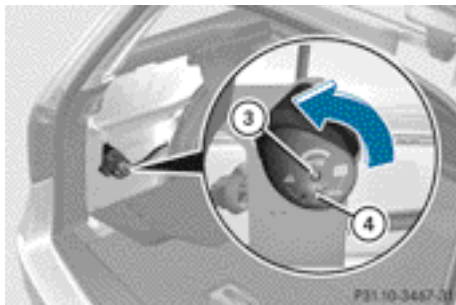

Estate

To unlock and fold out the ball coupling (Estate):

- ▶ Grip release wheel (4) so that your thumb lies on the thumb rest.
- ▶ Turn release wheel (4) anti-clockwise until the ball coupling releases and folds out from under the rear bumper. Indicator lamp (3) flashes.



- ▶ Pull the ball coupling in the direction of the arrow until it engages in a vertical position.

Saloon: indicator lamp ④ goes out.

Estate: indicator lamp ③ goes out.

The multifunction display shows the **Trailer hitch Check Lock mech.** message until the ball coupling is engaged.

- ▶ Remove the protective covering from the ball coupling and store it in a safe place.
- ▶ Make sure that the ball of the ball coupling is clean and greased.

The power socket is integrated in the ball coupling.

HYBRID vehicles: make sure that you read the "HYBRID" supplement included in the vehicle literature. Otherwise, you may not recognise dangers.

Coupling up a trailer

- ▶ Make sure that the transmission is in position **P**.
- ▶ Apply the parking brake.
- ▶ Position the trailer level behind the vehicle.
- ▶ Couple up the trailer.
- ▶ Establish the electric connection between the vehicle and the trailer.
- ▶ Check that the trailer lighting system is working.

A trailer that is connected is recognised only when the electrical connection is established correctly and when the lighting system is working properly. The function of other systems, such as ESP®, PARKTRONIC

and Active Parking Assist also depends on this.

Uncoupling a trailer

WARNING

If you uncouple a trailer with an engaged overrun brake, you could trap your hand between the vehicle and the trailer drawbar. This poses a risk of injury.

Do not uncouple a trailer with an engaged overrun brake.

WARNING

Vehicles with level control:

If you disconnect the trailer cable, the vehicle is lowered. This can cause you or others to become trapped between the vehicle body and tyres, or underneath the vehicle. This poses a risk of injury.

Make sure that no-one is in the immediate vicinity of the wheel arch or underneath the vehicle when disconnecting the trailer cable.

- ❗ Do not disconnect a trailer with an engaged overrun brake. Otherwise, your vehicle could be damaged by the rebounding of the overrun brake.

- ▶ Make sure that the transmission is in position **P**.
- ▶ Apply the parking brake.
- ▶ Secure the trailer against rolling away.
- ▶ Remove the trailer cable and decouple the trailer.

Folding in the ball coupling

WARNING

If you release the ball coupling or it does not engage correctly when folding in, it will swing out. Within pivoting range of the ball coupling, there is an increased risk of an accident and injury.

Only release the ball coupling if the pivoting range is unobstructed. Always make sure that the ball coupling engages when folding in.

- ▶ Place the protective covering on the ball coupling.

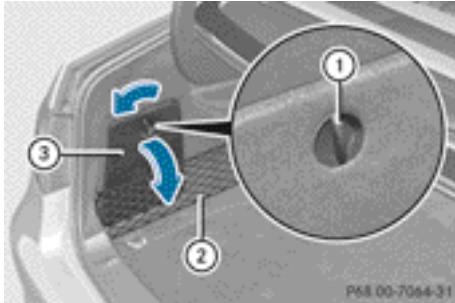

Saloon

The release wheel is located behind the left-hand side trim panel in the boot/luggage compartment.

To open the cover (Saloon):

- ▶ Slide luggage net (2) down.
- ▶ Turn handle (1) anti-clockwise and fold down cover (3).

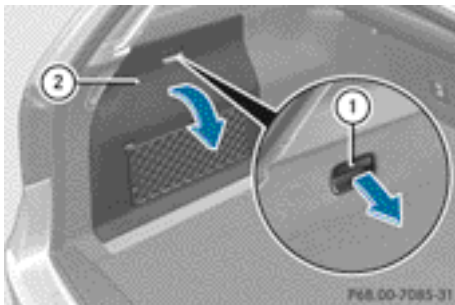

Estate

The release wheel is located behind the left-hand side trim panel in the boot/luggage compartment.

To open the cover (Estate):

- ▶ Pull handle (1) in the direction of the arrow and fold cover (2) down.

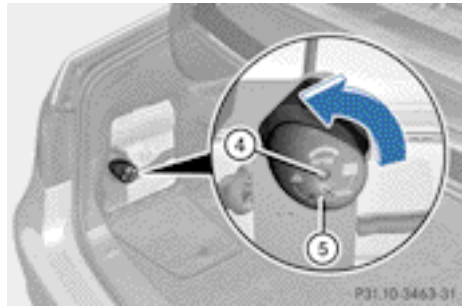

Saloon

To unlock and lower the ball coupling (Saloon):

- ▶ Grasp release wheel (5) with your hand such that the thumb is in the thumb rest and turn it anti-clockwise. The ball coupling unlocks and lowers. Indicator lamp (4) flashes.

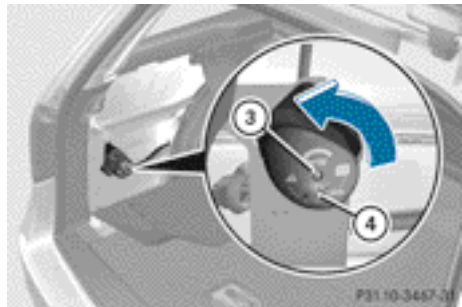

Estate

To unlock and lower the ball coupling (Estate):

- ▶ Grasp release wheel (4) with your hand such that the thumb is in the thumb rest and turn it anti-clockwise. The ball coupling unlocks and lowers. Indicator lamp (3) flashes.



- ▶ Press the ball coupling in the direction of the arrow until it engages behind the bumper.

Saloon: indicator lamp ④ goes out and the message in the multifunction display disappears.

Estate: indicator lamp ③ goes out and the message in the multifunction display disappears.

- ❗ Fold the ball coupling back in if you are not using the trailer tow hitch.

Trailer power supply

- ❗ You can connect accessories with a power rating of up to 240 W to the permanent power supply and with a power rating of up to 180 W to the power supply that is switched on via the ignition lock.

The trailer battery may not be charged from the power supply.

- ▶ **To switch the connected power supply on or off:** turn the key in the ignition lock to position **2** or **0** respectively (▷ page 177).

When it leaves the factory, your vehicle's trailer socket is equipped with a permanent power supply and a power supply that is switched on via the ignition lock.

The permanent power supply is supplied via trailer socket pin 9.

The power supply that is switched on via the ignition lock is supplied via trailer socket pin 10.

The trailer's permanent power supply is switched off in the event of low vehicle supply voltage and after six hours at the latest.

You can find more information about installing the trailer electrics at a qualified specialist workshop.

Bulb failure indicator for LED lamps

- ❗ If LED lamps are fitted in the trailer, an error message may appear in the multifunction display even if there is no fault. The reason for the error message could be that the current has fallen below the minimum of 50 mA.

To ensure reliable operation of the bulb failure indicator, each LED chain in the trailer lighting must be guaranteed a minimum current of 50 mA.

Trailer with 7-pin connector

General notes

Trailer with 7-pin connector: you can connect to the 13-pin socket on the ball coupling using an adapter or, if necessary, an adapter cable. Both can be obtained at a qualified specialist workshop.

Fitting the adapter

- ❗ Make sure that there is sufficient cable play so that the cable cannot become detached when cornering.

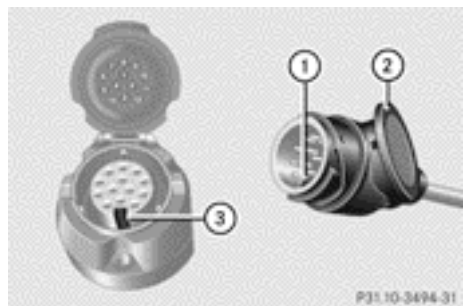

- ▶ Open the socket cover.
- ▶ Insert the plug connector with lug ① into groove ③ on the socket. Turn bayonet connection ② clockwise to the stop.
- ▶ Let the cover engage.
- ▶ If you are using an adapter cable, secure the cable to the trailer with cable ties.

Useful information	268
Important safety notes	268
Displays and operation	268
Menus and submenus	271
Display messages	290
Warning and indicator lamps in the instrument cluster	319

Useful information

- i** This Owner's Manual describes all models, series and optional equipment for your vehicle that were available at the time of going to press. National variations are possible. Note that your vehicle may not be equipped with all of the functions described. This is also the case for systems and functions relevant to safety.
- i** Read the information on qualified specialist workshops: (▷ page 26).

Important safety notes

WARNING

Operating the integrated information systems and communications equipment in the vehicle while driving will distract you from traffic conditions. You could then lose control of the vehicle. There is a risk of an accident.

Only operate these devices if road traffic conditions permit. If you are unsure about the surrounding conditions, pull over to a safe location and make entries only while the vehicle is stationary.

WARNING

If the instrument cluster has failed or malfunctioned, you may not recognise function restrictions relevant to safety. The operating safety of your vehicle may be impaired. There is a risk of an accident.

Drive on carefully. Have the vehicle checked at a qualified specialist workshop immediately.

You must observe the legal requirements for the country in which you are currently driving when operating the on-board computer.

The on-board computer only shows messages or warnings from certain systems in the multifunction display. You should therefore make sure your vehicle is operating safely at all

times. Otherwise, a vehicle that is not operating safely may cause an accident.

HYBRID vehicles: make sure that you read the "HYBRID" Supplement. You could otherwise fail to recognise dangers, e.g. due to high-voltage.

For an overview; see the instrument panel illustration (▷ page 32).

Displays and operation

Coolant temperature gauge

WARNING

If you open the bonnet while the engine is overheating or while there is a fire in the engine compartment, you could come into contact with hot gases or other leaking service products. There is a danger of injury. Allow an overheating engine to cool down before opening the bonnet. If there is a fire in the engine compartment, leave the bonnet closed and notify the fire brigade.

The coolant temperature gauge is in the instrument cluster on the left-hand side (▷ page 32).

Under normal operating conditions and with the specified coolant level, the coolant temperature may rise to 120 °C.

At high outside temperatures and when driving uphill, the coolant temperature may rise to the end of the scale.

Rev counter

- !** Do not drive in the overrevving range. Doing so will damage the engine.

The red band in the rev counter indicates the engine's overrevving range.

The fuel supply is interrupted to protect the engine when the red band is reached.

Outside temperature display

You should pay special attention to road conditions when temperatures are around the freezing point.

The outside temperature display is in the multifunction display (▷ page 270).

Changes in the outside temperature are displayed after a short delay.

Speedometer with segments

The segments in the speedometer indicate which speed range is available.

- Cruise control activated (▷ page 205):
The segments light up from the stored speed to the maximum speed.
- Variable SPEEDTRONIC activated (▷ page 208):
The segments light up from the start of the scale to the selected limit speed.
- DISTRONIC PLUS activated (▷ page 211):
One or two segments in the set speed range light up.
- DISTRONIC PLUS detects a vehicle in front:
The segments between the speed of the vehicle in front and the stored speed light up.

Operating the on-board computer

Overview

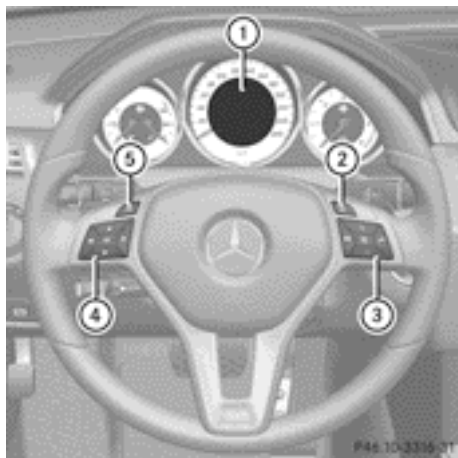







- ① Multifunction display
- ② Switches on LINGUATRONIC; see the separate operating instructions
- ③ Right control panel
- ④ Left control panel
- ⑤ Back button



► **To activate the on-board computer:** turn the key to position **1** in the ignition lock.



You can control the multifunction display and the settings in the on-board computer using the buttons on the multifunction steering wheel.

Left control panel



	<ul style="list-style-type: none"> • Calls up the menu and menu bar
	
	Press briefly:
	<ul style="list-style-type: none"> • Scrolls through lists • Selects a submenu or function • In the Audio menu: selects a stored station, an audio track or a video scene • In the Tel (telephone) menu: switches to the phone book and selects a name or telephone number
	Press and hold:
	<ul style="list-style-type: none"> • In the Audio menu: selects the previous/next station or selects an audio track or a video scene using rapid scrolling • In the Tel (Telephone) menu: starts rapid scrolling if the phone book is open
	<ul style="list-style-type: none"> • Confirms selection/display message • In the Tel (Telephone) menu: switches to the telephone book and starts dialling the selected number • In the Audio menu: stops the station search function at the desired station

Right control panel

	<ul style="list-style-type: none"> • Rejects or ends a call • Exits telephone book/redial memory
	<ul style="list-style-type: none"> • Makes or accepts a call • Switches to the redial memory

	• Adjusts the volume
	
	• Mute

Back button



	Press briefly:
	<ul style="list-style-type: none"> • Back • Switches off LINGUATRONIC; see the separate operating instructions • Hides display messages/calls up the last Trip menu function used • Exits the telephone book/redial memory
	Press and hold:
	<ul style="list-style-type: none"> • Calls up the standard display in the Trip menu

Multifunction display









Example: DIRECT SELECT automatic transmission multifunction display

- ① Text field
- ② Menu bar
- ③ Drive program (▷ page 187)
- ④ Transmission position (▷ page 187)
- ⑤ Permanent display: outside temperature or speed (▷ page 281)

► **To show menu bar**②: press the  or  button on the steering wheel.

Menu bar ② disappears after a few seconds. Text field ① shows the selected menu or submenu as well as display messages. The following messages may appear in the multifunction display:

- ↑ Gearshift recommendation, manual transmission (▷ page 186) or automatic transmission (▷ page 191)
- ← P → Active Parking Assist (▷ page 232)
-  Cruise control (▷ page 205)
-  SPEEDTRONIC (▷ page 208)
-  Adaptive Highbeam Assist (▷ page 143)
-  Adaptive Highbeam Assist PLUS (▷ page 144)
-  ECO start/stop function (▷ page 181)
-  HOLD function (▷ page 221)
- 120 km/h!** Maximum permissible speed exceeded (only for certain countries)

- **Settings** menu (settings) (▷ page 280)
 - **AMG** menu in AMG vehicles (▷ page 287)
- The **Audio**, **Navi** and **Tel** menus differ slightly in vehicles with an audio system and in vehicles with COMAND Online. The examples given in this Owner's Manual apply to vehicles equipped with COMAND Online.

Trip menu





Standard display

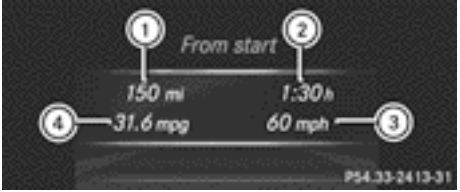

- ▶ Press and hold the  button on the steering wheel until the **Trip** menu with trip meter ① and total distance recorder ② is shown.

Trip computer "From start" or "From reset"





- Example: "From start" trip computer
- ① Distance
 - ② Time
 - ③ Average speed
 - ④ Average fuel consumption
- ▶ Press the  or  button on the steering wheel to select the **Trip** menu.
 - ▶ Press the  or  button to select **From start** or **From reset**.

The values in the **From start** submenu are calculated from the start of a journey whilst

Menus and submenus

Menu overview

Press the  or  button on the steering wheel to call up the menu bar and select a menu.

Operating the on-board computer (▷ page 269).

Depending on the equipment fitted in the vehicle, you can call up the following menus:

- **Trip** menu (▷ page 271)
- **Navi** menu (navigation instructions) (▷ page 273)
- **Audio** menu (▷ page 274)
- **Tel** menu (telephone) (▷ page 276)
- **Assist.** menu (assistance) (▷ page 277)
- **Serv.** menu (▷ page 280)

the values in the **From reset** submenu are calculated from the last time the submenu was reset (▷ page 272).

The **From start** trip computer is automatically reset if:

- the ignition has been switched off for more than four hours.
- 999 hours have been exceeded.
- 9999 kilometres have been exceeded.

The **From reset** trip computer is automatically reset if the value exceeds 9999 hours or 99,999 kilometres.

ECO display



Example: ECO display

- ▶ Press the or button on the steering wheel to select the **Trip** menu.
- ▶ Press the or button to select **ECO DISPLAY**.

If the ignition remains switched off for longer than four hours, the ECO display will be automatically reset.

For further information on the ECO display, see (▷ page 201).

Displaying the range and current fuel consumption



- ▶ Press the or button on the steering wheel to select the **Trip** menu.
- ▶ Press the or button to select the current fuel consumption (not for AMG vehicles) and the approximate range.

The approximate range which can be covered depends on the fuel level and your current driving style. If there is only a small amount of fuel left in the fuel tank, the display shows a vehicle being refuelled instead of the range.

Digital speedometer



- ① Gearshift recommendation, manual transmission (▷ page 186) or automatic transmission (▷ page 191)
 - ② Digital speedometer
- ▶ Press the or button on the steering wheel to select the **Trip** menu.
 - ▶ Press the or button to select the digital speedometer.

Resetting values



Example: resetting the trip computer "From start"

- ▶ Press the or button on the steering wheel to select the **Trip** menu.
- ▶ Press the or button to select the function that you wish to reset.

- ▶ Press the **OK** button.
- ▶ Press the **▼** button to select **Yes** and press the **OK** button to confirm.

You can reset the values of the following functions:

- trip meter
- trip computer "From start"
- trip computer "From reset"
- ECO display

- i** If you reset the values in the ECO display, the values in the "From start" trip computer are also reset. If you reset the values in the "From start" trip computer, the values in the ECO display are also reset.

Navigation menu

Displaying navigation instructions

In the **Navi** menu, the multifunction display shows navigation instructions. For more information on navigation, see the separate operating instructions.

- ▶ Switch on the audio system with Becker® MAP PILOT or COMAND Online; see the separate operating instructions.
- ▶ Press the **◀** or **▶** button on the steering wheel to select the **Navi** menu.

Route guidance not active



- ① Direction of travel
- ② Current road

Activating route guidance

No change of direction announced



- ① Distance to the destination
- ② Distance to the next change of direction
- ③ Current road
- ④ Symbol indicating "follow the road's course"

Change of direction announced without a lane recommendation



- ① Road to which the change of direction leads
- ② Distance to change of direction and visual distance display
- ③ Change-of-direction symbol

When a change of direction is announced, you will see change-of-direction symbol ③ and distance graphic ②. This shortens towards the top of the display as you approach the point of the announced change of direction.

Change of direction announced with a lane recommendation



- ① Road to which the change of direction leads
- ② Distance to change of direction and visual distance display
- ③ New lane during a change of direction
- ④ Lane continues through change of direction
- ⑤ Lane recommendation
- ⑥ Change-of-direction symbol

On multilane roads, the system can display a new lane recommendation ③ for the next change of direction. During the change of direction, additional lanes may be displayed. Lane recommendations are only displayed if the relevant data is available on the digital map.

Other status indicators of the navigation system







- : you have reached the destination or an intermediate destination.
- **New route...** or **Calculating route:** calculating a new route
- **Off map** or **Off road:** the vehicle position is outside the area of the digital map (off-map position).
- **No route:** no route could be calculated to the selected destination.

Audio menu



Selecting a radio station



- ① Waveband
 - ② Channel frequency with memory position
- i** Station ② is displayed with the station frequency or station name. The memory position is only displayed along with station ② if this has been stored.

- ▶ Switch on the audio system or COMAND Online and select Radio; see the separate operating instructions.
- ▶ Press the  or  button on the steering wheel to select the **Audio** menu.
- ▶ **To select a stored station:** briefly press the  or  button.
- ▶ **To select a station from the station list:** press and briefly hold the  or  button.

If no station list is received:

- ▶ **To select a station using the station search:** press and briefly hold the  or  button.

- i** For information on switching wavebands and storing stations, see the separate operating instructions.
- i** DAB radio mode (**D**igital **A**udio **B**roadcasting); see the separate operating instructions.

Audio player or audio media operation



Example: CD/DVD changer display

① Current track

Audio data from various audio devices or media can be played, depending on the equipment fitted in the vehicle.

- ▶ Switch on the audio system or COMAND Online and select audio CD, audio DVD or MP3 mode; see the separate operating instructions.
- ▶ Press the ◀ or ▶ button on the steering wheel to select the **Audio** menu.
- ▶ **To select the next/previous track:** briefly press the ▲ or ▼ button.
- ▶ **To select a track from the track list (rapid scrolling):** press and hold the ▲ or ▼ button until desired track ① has been reached.

If you press and hold the ▲ or ▼ button, the rapid scrolling speed is increased. Not all audio devices or media support this function.

If track information is stored on the audio device or medium, the multifunction display will show the number and title of the track. The current track does not appear in audio AUX mode (**A**uxiliary audio mode: external audio source connected).

TV operation



① Channel frequency with memory position

- ▶ The memory position is only displayed along with channel ① if this has been stored.
- ▶ Switch on COMAND Online and select TV; see the separate operating instructions.
- ▶ Press the ◀ or ▶ button on the steering wheel to select the **Audio** menu.
- ▶ **To select a stored channel:** briefly press the ▲ or ▼ button.
- ▶ **To select a channel from the channel list:** press and briefly hold the ▲ or ▼ button.
- ▶ Storing a TV channel; see the separate operating instructions.
- ▶ Depending on the digital TV broadcaster, radio stations can also be received. The multifunction display shows **TV (RADIO)**.





Video DVD operation



Example: CD/DVD changer display

① Current scene

- ▶ Switch on the audio system or COMAND Online and select video DVD; see the separate operating instructions.
- ▶ Press the ◀ or ▶ button on the steering wheel to select the **Audio** menu.

- ▶ **To select the next or previous scene:** briefly press the  or  button.
- ▶ **To select a scene from the scene list (rapid scrolling):** press and hold the  or  button until desired scene ① has been reached.

Telephone menu

Introduction

WARNING



Operating the integrated information systems and communications equipment in the vehicle while driving will distract you from traffic conditions. You could then lose control of the vehicle. There is a risk of an accident.

Only operate these devices if road traffic conditions permit. If you are unsure about the surrounding conditions, pull over to a safe location and make entries only while the vehicle is stationary.

When telephoning, you must observe the legal requirements for the country in which you are currently driving.

- ▶ Switch on the mobile phone; see the separate operating instructions.
- ▶ Switch on the audio system or COMAND Online; see the separate operating instructions.
- ▶ Insert the mobile phone into the bracket (> page 353).

or

- ▶ Establish a Bluetooth® connection to COMAND Online; see the separate operating instructions.
- ▶ Press the  or  button on the steering wheel to select the **Te1** menu.

You will see one of the following display messages in the multifunction display:

- **Please enter PIN:** the mobile phone has been placed in the mobile phone bracket and the PIN has not been entered.

When you enter your PIN via the mobile phone, LINGUATRONIC, the audio system or COMAND Online, the mobile phone searches for a network.

- **Telephone ready** or the name of the network provider: the mobile phone has found a network and is ready to receive.
- **Telephone No service:** there is no network available or the mobile phone is searching for a network.

i You can obtain further information about suitable mobile phones and connecting mobile phones via Bluetooth®:

- from any Mercedes Benz Service Centre
- on the Internet at: <http://www.mercedes-benz.com/connect>

Accepting a call

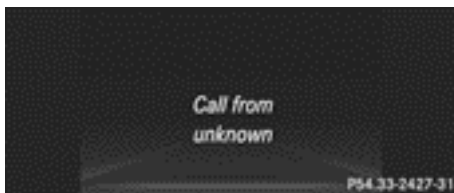

Example: incoming call

- ▶ Press the  button on the steering wheel to accept an incoming call.

If someone calls you when you are in the **Te1** menu, a display message appears in the multifunction display.

You can accept a call even if you are not in the **Te1** menu.

Rejecting or ending a call

- ▶ Press the  button on the steering wheel.

You can end or reject a call even if you are not in the **Te1** menu.

Dialling an entry from the phone book

- ▶ Press the ◀ or ▶ button on the steering wheel to select the **Tel** menu.
- ▶ Press the ▲, ▼ or OK button to switch to the phone book.
- ▶ Press the ▲ or ▼ button to select the desired name.

or

- ▶ **To begin rapid scrolling:** press and hold the ▲ or ▼ button for longer than one second.
Rapid scrolling stops when you release the button or reach the end of the list.
- ▶ **If only one telephone number is stored for a name:** press the ☎ or OK button to start dialling.

or

- ▶ **If there is more than one number for a particular name:** press the ☎ or OK button to display the numbers.
- ▶ Press the ▲ or ▼ button to select the number you want to dial.
- ▶ Press the ☎ or OK button to start dialling.

or

- ▶ **To exit the telephone book:** press the ☎ or ↩ button.

Redialling

The on-board computer saves the last names or numbers dialled in the redial memory.

- ▶ Press the ◀ or ▶ button on the steering wheel to select the **Tel** menu.
- ▶ Press the ☎ button to switch to the redial memory.
- ▶ Press the ▲ or ▼ button to select the desired name or number.
- ▶ Press the ☎ or OK button to start dialling.

or

- ▶ **To exit the redial memory:** press the ☎ or ↩ button.

Assistance menu

Introduction

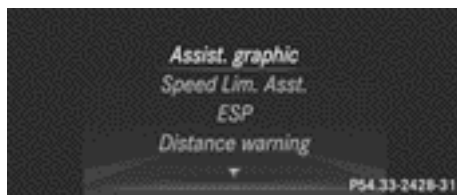

In the **Assist.** menu, you have the following options:





- Showing the assistance graphic (▷ page 277)
- Activating/deactivating the Traffic Sign Assist message function (▷ page 278)
- Activating/deactivating ESP® (▷ page 278)
- Activating/deactivating PRE-SAFE® Brake (▷ page 278)
- Activating/deactivating ATTENTION ASSIST (▷ page 279)
- Activating/deactivating the distance warning function (▷ page 279)
- Activating/deactivating Steering Assist of DISTRONIC PLUS (▷ page 279)
- Activating/deactivating Blind Spot Assist or Active Blind Spot Assist (▷ page 279)
- Activating/deactivating Lane Keeping Assist or Active Lane Keeping Assist (▷ page 279)

Showing the assistance graphic







- ▶ Press the ◀ or ▶ button on the steering wheel to select the **Assist.** menu.
- ▶ Press ▲ or ▼ to select **Assist. graphic**.
- ▶ Press the OK button.
The multifunction display shows the DISTRONIC PLUS distance display in the assistance graphic (▷ page 217).
- ▶ Press ▲ or ▼ to display the ATTENTION ASSIST assessment (▷ page 246).

The assistance graphic can display the status of and information from other driving systems or driving safety systems.

The assistance graphic shows:

- the  symbol when ATTENTION ASSIST (▷ page 246) is deactivated.
- the lane markings as bright lines when Lane Keeping Assist (▷ page 252) or Active Lane Keeping Assist (▷ page 256) is activated.
- the  symbol appears if Traffic Sign Assist (▷ page 247) is operational. The assistance graphic can also display traffic signs that are detected and indicate speed limits.
- the  symbol when the distance warning function (▷ page 75) is deactivated.
- the  symbol when PRE-SAFE® Brake (▷ page 81) is deactivated.

Activating/deactivating the Traffic Sign Assist message function

- ▶ Press the  or  button on the steering wheel to select the **Assist.** menu.
- ▶ Using  or , select **Traffic Sign Assist.**
- ▶ Press the  button.
The current selection is displayed.
- ▶ **To activate or deactivate:** press .

If the messages are activated, recognised traffic signs are displayed in the multifunction display for five seconds (▷ page 247).

Deactivating/activating ESP®

- ❗ Observe the "Important safety notes" section in the description of ESP (▷ page 77).

WARNING

If you deactivate ESP®, ESP® no longer stabilises the vehicle. There is an increased risk of skidding and an accident.







Only deactivate ESP® in the situations described in the following.

It may be best to deactivate ESP® in the following situations:



- when using snow chains
- in deep snow
- on sand or gravel

Activating/deactivating ESP® on AMG vehicles (▷ page 79).

For further information about ESP®; see (▷ page 77).

- ▶ Start the engine.
- ▶ Press the  or  button on the steering wheel to select the **Assist.** menu.
- ▶ Press the  or  button to select **ESP.**
- ▶ Press the  button.
The current selection is displayed.
- ▶ **To activate/deactivate:** press the  button again.

ESP® is deactivated if the  warning lamp in the instrument cluster lights up continuously when the engine is running.





If the  warning lamp and the  warning lamp are lit continuously, ESP® is not available due to a malfunction.



Observe the information on warning lamps (▷ page 322).

Observe the information on display messages (▷ page 291).

Activating/deactivating PRE-SAFE® Brake







PRE-SAFE® Brake is only available in vehicles with DISTRONIC PLUS.

- ▶ Press the  or  button on the steering wheel to select the **Assist.** menu.
- ▶ Press the  or  button to select **PRE-SAFE Brake.**

- ▶ Press the  button.
The current selection is displayed.
- ▶ **To activate/deactivate:** press the  button again.
When PRE-SAFE® Brake is deactivated, the assistance graphic shows the  symbol in the multifunction display.

For more information on PRE-SAFE® Brake, see (> page 81).







Activating/deactivating the distance warning function

- ▶ Press the  or  button on the steering wheel to select the **Assist.** menu.
- ▶ Press  or  to select **Distance warning.**
- ▶ Press the  button.
The current selection is displayed.
- ▶ **To activate/deactivate:** press the  button again.

When the distance warning function is deactivated, the assistance graphic shows the  symbol in the multifunction display.











Further information on the distance warning function (> page 75).

Activating/deactivating Steering Assist of DISTRONIC PLUS

- ▶ Press the  or  button on the steering wheel to select the **Assist.** menu.
- ▶ Using  or , select **DTR+: steer. asst.**
- ▶ Press the  button.
The current selection is displayed.
- ▶ **To activate/deactivate:** press the  button again.
When the steering assist of DISTRONIC PLUS is activated, the multifunction display shows the **DTR+: steering assistantion** message.







For further information on the steering assist of DISTRONIC PLUS: (> page 220).

Activating/deactivating ATTENTION ASSIST

- ▶ Press the  or  button on the steering wheel to select the **Assist.** menu.
- ▶ Press the  or  button to select **Attention Assist.**
- ▶ Press the  button.
The current selection is displayed.
- ▶ Press  to confirm.
- ▶ Press the  or  button to set **Off, Standard** or **Sensitive.**
- ▶ Press the  button to save the setting.
When ATTENTION ASSIST is deactivated, the  symbol appears in the multifunction display in the assistance graphic.

For further information about ATTENTION ASSIST, see (> page 246).







Activating/deactivating Blind Spot Assist



- ▶ Press the  or  button on the steering wheel to select the **Assist.** menu.
- ▶ Press the  or  button to select **Blind Spot Assist.**
- ▶ Press the  button.
The current selection is displayed.
- ▶ **To activate/deactivate:** press the  button again.

For further information about Blind Spot Assist, see (> page 250).

For further information about Active Blind Spot Assist, see (> page 254).

Activating/deactivating Lane Keeping Assist

- ▶ Press the  or  button on the steering wheel to select the **Assist.** menu.
- ▶ Press the  or  button to select **Lane Keep. Assist**
- ▶ Press the  button.
The current selection is displayed.
- ▶ Press  to confirm.

- ▶ Press the  or  button to set **Off**, **Standard** or **Adaptive**.
- ▶ Press the  button to save the setting. When Lane Keeping Assist or Active Lane Keeping Assist is activated, the multifunction display shows the lane markings as bright lines in the assistance graphic.

For further information about Lane Keeping Assist; see (▷ page 252).

For further information about Active Lane Keeping Assist; see (▷ page 256).

Service menu



In the **Serv.** menu, you have the following options:

- Calling up display messages in message memory (▷ page 290)
- Restarting the tyre pressure loss warning system (▷ page 410)
- Checking the tyre pressure electronically (▷ page 410)
- Calling up the service due date (▷ page 370)

Settings menu

Introduction



In the **Settings** menu, you have the following options:









- Changing the instrument cluster settings (▷ page 280)
- Changing the light settings (▷ page 281)
- Changing the vehicle settings (▷ page 284)
- Changing the auxiliary heating settings (▷ page 284)
- Changing the convenience settings (▷ page 285)
- Restoring the factory settings (▷ page 286)

Instrument cluster

Selecting the unit of measurement for distance

The **Display unit Speed-/odometer:** function allows you to choose whether certain displays appear in kilometres or miles in the multifunction display.

You can determine whether the multifunction display shows some messages in miles or kilometres.

- ▶ Press the  or  button on the steering wheel to select the **Settings** menu.
- ▶ Press the  or  button to select the **Inst. cluster** submenu.
- ▶ Press  to confirm.
- ▶ Press the  or  button to select the **Display unit Speed-/odometer:** function. You will see the selected setting: **km** or **miles**.
- ▶ Press the  button to save the setting.

The selected unit of measurement for distance applies to:

- the digital speedometer in the **Trip** menu
- total distance recorder and the trip meter
- trip computer
- current consumption and the range
- the navigation instructions in the **Navi** menu
- cruise control

- SPEEDTRONIC
- DISTRONIC PLUS
- ASSYST PLUS service interval display









Switching the additional speedometer on/off

Vehicles for the United Kingdom: this function is unavailable.

Only vehicles with manual transmission have this function.

The **Addit. Speedo [mph]** function allows you to choose whether the status area in the multifunction display shows the speed in mph instead of the outside temperature.





You can determine whether the multifunction display permanently shows your speed or the outside temperature.



- ▶ Press the  or  button on the steering wheel to select the **Settings** menu.
- ▶ Press the  or  button to select the **Inst. cluster** submenu.
- ▶ Press  to confirm.
- ▶ Press the  or  button to select the **Addit. speedo [mph]** function.
You will see the selected setting: **on** or **off**.
- ▶ Press the  button to save the setting.

Selecting the permanent display function

Vehicles for the United Kingdom: this function is unavailable.

You can determine whether the multifunction display permanently shows your speed or the outside temperature.

- ▶ Press the  or  button on the steering wheel to select the **Settings** menu.
- ▶ Press the  or  button to select the **Inst. cluster** submenu.
- ▶ Press  to confirm.















- ▶ Press the  or  button to select the **Permanent display** function.
You will see the selected setting: **outside temperature** or **Addit. speedo [mph]**.
- ▶ Press the  button to save the setting.

-  The speed is displayed in mph.

Lights









Setting the brightness for the instrument cluster lighting and switches

The lighting in the instrument cluster, in the displays and the controls in the vehicle interior can be adjusted using the **Brightness Display/switches:** function.

- ▶ Press the  or  button on the steering wheel to select the **Settings** menu.
- ▶ Press the  or  button to select the **Light** submenu.
- ▶ Press  to confirm.
- ▶ Press the  or  button to select the **Brightness Display/Switches:** function.
You will see the selected setting.
- ▶ Press  to confirm.
- ▶ Press the  or  button to adjust the brightness to any level from **Level 1** to **Level 5** (bright).
- ▶ Press the  or  button to save the setting.
If the light switch is set to **AUTO**,  or , the brightness is dependent upon the brightness of the ambient light.
-  The light sensor in the instrument cluster automatically controls the brightness of the multifunction display.
In daylight, the displays in the instrument cluster are not illuminated.









Switching the daytime driving lights on/off

The **Day lights** function can only be switched on with the engine turned off.

- ▶ Press the  or  button on the steering wheel to select the **Settings** menu.
- ▶ Press the  or  button to select the **Light** submenu.
- ▶ Press  to confirm.
- ▶ Press the  or  button to select the **Day lights** function.
If the **Day lights** function has been switched on, the cone of light and the  symbol in the multifunction display are shown in orange.
- ▶ Press the  button to save the setting.

Further information on daytime driving lights (▷ page 137).

Switching the Intelligent Light System on/off

- ▶ Press the  or  button on the steering wheel to select the **Settings** menu.
- ▶ Press the  or  button to select the **Light** submenu.
- ▶ Press  to confirm.
- ▶ Press the  or  button to select the **Intell. Light Sys.** function.
If the **Intell. Light Sys.** function has been switched on, the cone of light and the  symbol in the multifunction display are shown in orange.
- ▶ Press the  button to save the setting.









When you activate **Intell. Light Sys.**, you activate the following functions:

- motorway mode
- active light function
- cornering light function
- extended range foglamps

If you set the dipped-beam headlamps for driving on the right/left, the multifunction display shows the **Intell. Light System: System inoperative Inactive for left-side traffic** or **Intell. Light System: System inoperative Inactive for right-side traffic** display message instead of the **Intell. Light Sys.** function in the **Light** submenu (▷ page 282).

Further information on the Intelligent Light System (▷ page 141).

Setting the dipped-beam headlamps for driving on the left/right

- ▶ Press the  or  button on the steering wheel to select the **Settings** menu.
- ▶ Press the  or  button to select the **Light** submenu.
- ▶ Press  to confirm.
- ▶ Press the  or  button to select the **Dipped beams Setting for:** function.
You will see the selected setting: **Right-side traffic** or **Left-side traffic**.
- ▶ Press the  button to save the setting.
If you change the setting, conversion does not take place until the next time the vehicle is stationary.









This function is only available on vehicles with the Intelligent Light System.





You can use this function to switch between symmetrical and asymmetrical dipped beam (▷ page 136).

If you set the dipped-beam headlamps for driving on the right/left, then motorway mode and the extended range foglamps are unavailable.













A qualified specialist workshop can set the dipped-beam headlamps for driving on the right or left .

Setting the brightness of the ambient lighting









- ▶ Press the  or  button on the steering wheel to select the **Settings** menu.
- ▶ Press the  or  button to select the **Light** submenu.
- ▶ Press  to confirm.
- ▶ Press the  or  button to select the **Amb. light +/-** function.
You will see the selected setting.
- ▶ Press  to confirm.

- ▶ Press the  or  button to adjust the brightness to any level from **Off** to **Level 5** (bright).
- ▶ Press the  or  button to save the setting.

Setting the ambient lighting colour

- ▶ Press the  or  button on the steering wheel to select the **Settings** menu.
- ▶ Press the  or  button to select the **Light** submenu.
- ▶ Press  to confirm.
- ▶ Press the  or  button to select the **Ambient light colour** function.
- ▶ Press  to confirm.
- ▶ Press the  or  button to set the colour to **SOLAR**, **NEUTRAL** or **POLAR**.
- ▶ Press the  or  button to save the setting.

Activating/deactivating the surround lighting and exterior lighting delayed switch-off

- ▶ Press the  or  button on the steering wheel to select the **Settings** menu.
- ▶ Press the  or  button to select the **Light** submenu.
- ▶ Press  to confirm.
- ▶ Press the  or  button to select the **Surround lighting** function.
If the **Surround lighting** function is activated, the light cone and the area around the vehicle are displayed in orange in the multifunction display.
- ▶ Press the  button to save the setting.

Deactivating delayed switch-off of the exterior lighting temporarily:

- ▶ Before leaving the vehicle, turn the key to position **0** in the ignition lock.
- ▶ Turn the key to position **2** in the ignition lock.
The exterior lighting delayed switch-off is deactivated.

Delayed switch-off of the exterior lighting is reactivated the next time you start the engine.

If you have activated the **Surround lighting** function and the light switch is set to **AUTO**, the following functions are activated when it is dark:







- **surround lighting:** the exterior lighting remains lit for 40 seconds after unlocking with the key. If you start the engine, the surround lighting is switched off and automatic headlamp mode is activated (▷ page 137).
- **exterior lighting delayed switch-off:** the exterior lighting remains lit for 60 seconds after the engine is switched off. If you close all the doors and the boot lid/ tailgate, the exterior lighting goes off after 5 seconds.

i Depending on your vehicle's equipment, when the surround lighting and delayed switch-off exterior lighting are on, the following light up:

- side lamps
- dipped-beam headlamps
- daytime driving lights
- surround lighting in the exterior mirrors

Activating/deactivating the interior lighting delayed switch-off

If you activate the **Light. delay** function, the interior lighting remains on for 20 seconds after you remove the key from the ignition lock.











- ▶ Press the  or  button on the steering wheel to select the **Settings** menu.
- ▶ Press the  or  button to select the **Light** submenu.
- ▶ Press  to confirm.
- ▶ Press the  or  button to select the **Light. delay** function.
If the **Light. delay** function has been switched on, the vehicle interior is dis-

played in orange in the multifunction display.

- ▶ Press the  button to save the setting.









Vehicle

Setting permanent SPEEDTRONIC

- ▶ Press the  or  button on the steering wheel to select the **Settings** menu.
- ▶ Press the  or  button to select the **Vehicle** submenu.
- ▶ Press  to confirm.
- ▶ Press the  or  button to select the **Limit speed (winter tyres)**: function. You will see the current setting.
- ▶ Press  to confirm.
- ▶ Press the  or  button to adjust permanent SPEEDTRONIC in increments of ten (230 km/h to 160 km/h). The **Off** setting switches permanent SPEEDTRONIC off.
- ▶ Press the  button to store the entry.

For further information on permanent SPEEDTRONIC (▷ page 211).

Switching the automatic locking feature on/off









- ▶ Press the  or  button on the steering wheel to select the **Settings** menu.
- ▶ Press the  or  button to select the **Vehicle** submenu.
- ▶ Press  to confirm.
- ▶ Press the  or  button to select the **Auto. door locks** function. When the **Auto. door locks** function is activated, the vehicle doors are displayed in orange in the multifunction display.
- ▶ Press the  button to save the setting.

If you activate the **Auto. door locks** function, the vehicle is centrally locked above a speed of around 15 km/h.

For further information on the automatic locking feature; see (▷ page 96).

Activating/deactivating the acoustic locking confirmation

If you switch on the **Acoustic Lock** function, an acoustic signal sounds when you lock the vehicle.

- ▶ Press the  or  button on the steering wheel to select the **Settings** menu.
- ▶ Press the  or  button to select the **Vehicle** submenu.
- ▶ Press  to confirm.
- ▶ Press the  or  button to select the **Acoustic Lock** function. If the **Acoustic Lock** function is activated, the  symbol in the multifunction display lights up orange.
- ▶ Press the  button to save the setting.

Heating

Auxiliary heating departure time

DANGER

If the exhaust pipe is blocked or sufficient ventilation is not possible, toxic exhaust fumes can enter the vehicle, especially carbon monoxide. This is the case, e.g. in enclosed spaces, or if the vehicle is stuck in snow. There is a risk of fatal injuries.

You should switch off the auxiliary heating in enclosed spaces which do not have an extraction system, e.g. a garage. If the vehicle is stuck in snow and you must leave the auxiliary heating running, keep the exhaust pipe and the area around the vehicle clear of snow. To guarantee a sufficient supply of fresh air, open a window on the side of the vehicle away from the wind.

WARNING

When the auxiliary heating is switched on, parts of the vehicle can become very hot. Flammable material such as leaves, grass or twigs may ignite if they come into contact with hot parts of the exhaust system for extended periods. There is a risk of fire.

When the auxiliary heating is switched on, make sure that no flammable material can come into contact with hot vehicle components.

! Operating the auxiliary heating/ventilation draws on the vehicle battery. After you have heated or ventilated the vehicle a maximum of two times, drive for a longer distance.

Only vehicles with auxiliary heating have this function (▷ page 168).





In the **Heating** submenu, you can select a stored departure time or change a departure time.



The auxiliary heating timer function calculates the switch-on time according to the outside temperature so that the vehicle is preheated by the departure time. When the departure time is reached, the auxiliary heating continues to heat for a further five minutes and then switches off. The auxiliary heating adopts the THERMATIC or THERMOTRONIC temperature setting.

You can switch off the auxiliary heating by using the remote control or the auxiliary heating button on the centre console.

i Switch the auxiliary heating on regularly once a month for approximately ten minutes.

Selecting the departure time or deactivating a selected departure time











- ▶ Press the  or  button on the steering wheel to select the **Settings** menu.
- ▶ Press the  or  button to select the **Heating** submenu.
- ▶ Press **OK** to confirm.
You will see the selected setting.
- ▶ Press **OK** to confirm.

▶ Press the  or  button to select one of the three departure times or **Timer off** (no timer active).

▶ Press **OK** to confirm.

If a departure time is selected, the yellow indicator lamp lights up on the auxiliary heating button.

Changing the departure time

- ▶ Press the  or  button on the steering wheel to select the **Settings** menu.
- ▶ Press the  or  button to select the **Heating** submenu.
- ▶ Press **OK** to confirm.
You will see the selected setting.
- ▶ Press **OK** to confirm.
- ▶ Press the  or  button to select **A**, **B** or **Change C**.
- ▶ Press **OK** to confirm.
You can now change the departure time.
- ▶ Press the  or  button to select the display to be changed: hours, minutes.
- ▶ Press the  or  button to set the selected display.
- ▶ Press the **OK** button to store the entry.
The yellow indicator lamp on the auxiliary heating button lights up.

Comfort

Activating/deactivating the EASY-ENTRY/EXIT feature

WARNING

When the EASY-ENTRY/EXIT feature adjusts the steering wheel, you and other vehicle occupants – particularly children – could become trapped. There is a risk of injury.

While the EASY-ENTRY/EXIT feature is making adjustments, make sure that no one has any body parts in the sweep of the steering wheel.

If someone is trapped:

- press one of the memory function position buttons, or
- move the switch for steering wheel adjustment in the opposite direction to that in which the steering wheel is moving.

The adjustment process is stopped.

- ▶ Press the ◀ or ▶ button on the steering wheel to select the **Settings** menu.
- ▶ Press the ▼ or ▲ button to select the **Convenience** submenu.
- ▶ Press **OK** to confirm.
- ▶ Press the ▼ or ▲ button to select the **Easy Entry/Exit:** function.
If the **Easy Entry/Exit** function is activated, the vehicle steering wheel is displayed in orange in the multifunction display.
- ▶ Press the **OK** button to save the setting.

Further information on the EASY-ENTRY/EXIT feature (▷ page 128).

Switching belt adjustment on/off

- ▶ Press the ◀ or ▶ button on the steering wheel to select the **Settings** menu.
- ▶ Press the ▼ or ▲ button to select the **Convenience** submenu.
- ▶ Press **OK** to confirm.
- ▶ Press the ▼ or ▲ button to select the **Belt adjustment** function.
If the **Belt adjustment** function is activated, the vehicle seat belt is shown in orange in the multifunction display.
- ▶ Press the **OK** button to save the setting.

For further information on belt adjustment, see (▷ page 52).

Switching the fold in mirrors when locking function on/off

This function is only available on vehicles with a memory function (▷ page 132).

When you activate the **Auto. fold in** function, the exterior mirrors are folded in when the vehicle is locked. When you unlock the

vehicle and then open a door, the exterior mirrors fold out again.

- ▶ Press the ◀ or ▶ button on the steering wheel to select the **Settings** menu.
- ▶ Press the ▼ or ▲ button to select the **Convenience** submenu.
- ▶ Press **OK** to confirm.
- ▶ Press the ▼ or ▲ button to select the **Auto. fold in** function.
If the **Auto. fold in** function is activated, the vehicle's exterior mirror is displayed in orange in the multifunction display.
- ▶ Press the **OK** button to save the setting.

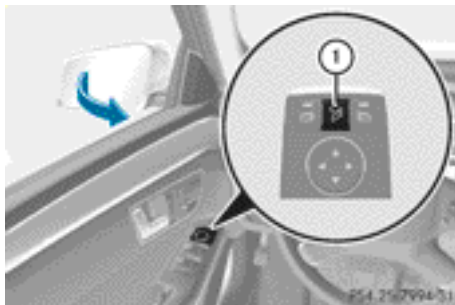



- ① To fold the exterior mirrors in or out

If you have switched on the **Auto. fold in** function and you fold the exterior mirrors in using button ① on the door, they will not fold out automatically (▷ page 130).

You can then only fold out the exterior mirrors using button ①.

Resetting to factory settings

- ▶ Press the ◀ or ▶ button on the steering wheel to select the **Settings** menu.
- ▶ Press the ▼ or ▲ button to select the **Factory setting** submenu.
- ▶ Press **OK** to confirm.
The **Reset all settings?** message appears.



- ▶ Press the  or  button to select **No** or **Yes**.
- ▶ Press the  button to confirm the selection.
If you have selected **Yes**, the multifunction display shows a confirmation message.

For safety reasons, not all functions are reset: the **Limit speed (winter tyres)** function in permanent SPEEDTRONIC can only be set in the **Vehicle** submenu. If you want to reset the **Daytime driving lights** in the **Light** submenu, you must turn the key to position 1 in the ignition lock.

AMG menu in AMG vehicles

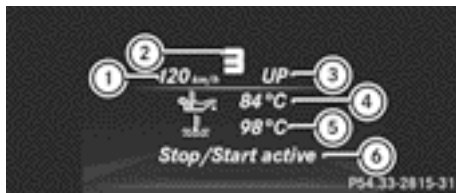
AMG displays



- ① Digital speedometer
 - ② Gear indicator
 - ③ Upshift indicator
 - ④ Engine oil temperature
 - ⑤ Coolant temperature
 - ⑥ Status indicator for ECO start/stop function (▶ page 181)
- ▶ Press the  or  button on the steering wheel to select the **AMG** menu.

Upshift indicator **UP**③ indicates that the engine has reached the overrevving range when in the manual gearshift program. Upshift indicator **UP**③ fades out other messages until you have shifted up.

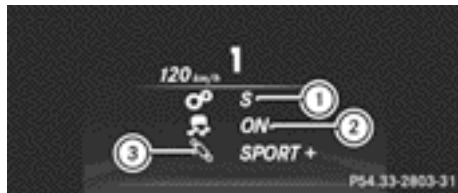

If the engine oil temperature is below 80 °C, the oil temperature is shown in blue. Avoid using the full output of the engine during this time.

SETUP



- ① Drive program (**C/SS+/M**)
- ② ESP® mode (**ON/OFF**) or SPORT handling mode (**SPORT**)
- ③ Suspension tuning (**COMFORT/SPORT/SPORT+**)

SETUP shows the drive program, the ESP® (Electronic Stability Program) mode and the suspension tuning.

- ▶ Press the  or  button on the steering wheel to select the **AMG** menu.
- ▶ Press the  button repeatedly until SETUP is displayed.

or

- ▶ Briefly press the AMG button on the centre console (▶ page 226).

RACETIMER





Displaying and starting the RACETIMER



- ① Lap
- ② RACETIMER



The RACETIMER is only intended for use on a closed race circuit. Do not use the function on public roads.

You can start the RACETIMER when the engine is running or if the key is in position **2** in the ignition lock.

- ▶ Press the  or  button on the steering wheel to select the **AMG** menu.
- ▶ Press the  button repeatedly until the RACETIMER is shown.
- ▶ **To start:** press the  button to start the RACETIMER.

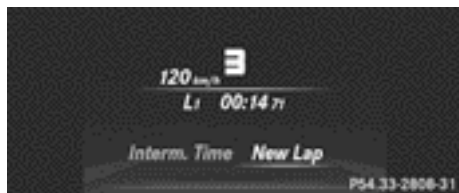
Displaying the intermediate time



- ▶ Press the  or  button to select **Interm. Time**.
- ▶ Press  to confirm.
The intermediate time is displayed for five seconds.

Starting a new lap

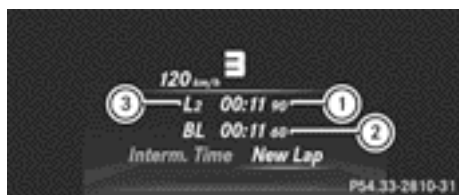



- ① RACETIMER
 - ② Fastest lap time (best lap)
 - ③ Lap
- ▶ Press  to confirm **New Lap**.

i It is possible to store a maximum of 16 laps. The 16th lap can only be completed with **Finish Lap**.



Stopping the RACETIMER



- ▶ Press the  button on the steering wheel.
- ▶ Confirm **Yes** with .

The RACETIMER interrupts timing if you stop the vehicle and turn the key to position **1** in the ignition lock. If you turn the key to position **2** or **3** and then press  to confirm **Start**, timing is continued.

Resetting the current lap

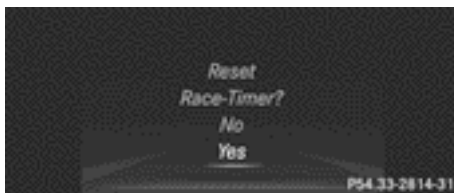

- ▶ Stop the RACETIMER.
- ▶ Press the  or  button to select **Reset Lap**.
- ▶ Press  to reset the lap time to "0".

Deleting all laps



If you switch off the engine, the RACETIMER is reset to "0" after 30 seconds. All laps are deleted.

You cannot delete individual stored laps. If you have stopped 16 laps, the current lap does not have to be reset.

- ▶ Reset the current lap.
- ▶ Press  to confirm **Reset**. **Reset Race Timer?** appears in the multi-function display.
- ▶ Press the  button to select **Yes** and press the  button to confirm.
All laps are deleted.

Overall evaluation



- ① RACETIMER overall evaluation
- ② Total time driven
- ③ Average speed
- ④ Distance covered
- ⑤ Maximum speed

This function is shown if you have stored at least one lap and stopped the RACETIMER.

- ▶ Press the ◀ or ▶ button on the steering wheel to select the **AMG** menu.
- ▶ Press the ▲ button repeatedly until the overall evaluation is shown.

Lap evaluation

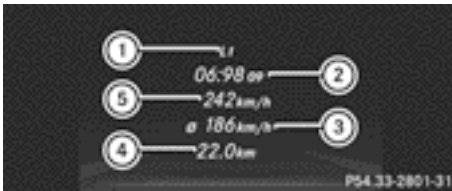

- ① Lap
- ② Lap time
- ③ Average lap speed
- ④ Lap length
- ⑤ Top speed during lap

This function is only available if you have stored at least two laps and have stopped the RACETIMER.

- ▶ Press the ◀ or ▶ button on the steering wheel to select the **AMG** menu.
- ▶ Press the ▲ button repeatedly until the lap evaluation is shown. Each lap is shown in a separate submenu. The fastest lap is indicated by flashing symbol ①.
- ▶ Press the ▲ or ▼ button to select a different lap evaluation.

Display messages

Introduction

General notes

Display messages appear in the multifunction display.

Display messages with graphic symbols are simplified in the Owner's Manual and may differ from the symbols in the multifunction display.

Please respond in accordance with the display messages and follow the additional notes in this Owner's Manual.



Certain display messages are accompanied by an audible warning tone or a continuous tone.

When the ignition is switched off, all display messages are deleted apart from some high-priority display messages. Once the causes of the high-priority display messages have been rectified, the corresponding display messages are also deleted.

When you stop and park the vehicle, please observe the notes on:

- HOLD function (▷ page 221)
- Parking (▷ page 199)

Hiding display messages







- ▶ Press the  or  button on the steering wheel to hide the display message. The display message is cleared.

The multifunction display shows high-priority display messages in red. Some high-priority display messages cannot be hidden.

The multifunction display shows these messages continuously until the causes for the messages have been remedied.

Message memory

The on-board computer saves certain display messages in the **message memory**. You can call up the display messages:

- ▶ Press the  or  button on the steering wheel to select the **Serv.** menu. If there are display messages, the multifunction display shows **2 messages**, for example.
- ▶ Press the  or  button to select the entry, e.g. **2 messages**.
- ▶ Press  to confirm.
- ▶ Press the  or  button to scroll through the display messages.

Safety systems

Display messages





currently unavailable See Owner's Manual

Possible causes/consequences and ► Solutions

ABS (Anti-lock Braking System), ESP[®] (Electronic Stability Program), BAS (Brake Assist), PRE-SAFE[®], the HOLD function, hill start assist and ESP[®] trailer stabilisation are temporarily unavailable.

The adaptive brake lights, BAS PLUS, COLLISION PREVENTION ASSIST and PRE-SAFE[®] Brake may also have failed.

In addition, the ,  and  warning lamps light up in the instrument cluster.

ATTENTION ASSIST is deactivated.

For example, the on-board voltage may be insufficient.

 **WARNING**

The brake system continues to function normally, but without the functions listed above. The wheels could therefore lock if you brake hard, for example.

The steerability and braking characteristics may be severely affected. The braking distance may increase in an emergency braking situation.

If ESP[®] is not operational, ESP[®] is unable to stabilise the vehicle. There is an increased danger of skidding and risk of an accident.

► Drive on carefully.

If the display message disappears, the functions mentioned above are available again.

If the display message continues to be displayed:

► Drive on carefully.





► Visit a qualified specialist workshop.



inoperative See Owner's Manual

ABS, ESP[®], BAS, PRE-SAFE[®], the HOLD function, hill start assist and ESP[®] trailer stabilisation are unavailable due to a malfunction.



The adaptive brake lights, BAS PLUS, COLLISION PREVENTION ASSIST and PRE-SAFE[®] Brake may also have failed.









In addition, the , ,  and  warning lamps light up in the instrument cluster.



ATTENTION ASSIST is deactivated.

 **WARNING**







The brake system continues to function normally, but without the functions listed above. The wheels could therefore lock if you brake hard, for example.







Display messages	Possible causes/consequences and ► Solutions
	<p>The steerability and braking characteristics may be severely affected. The braking distance may increase in an emergency braking situation.</p> <p>If ESP® is not operational, ESP® is unable to stabilise the vehicle. There is an increased danger of skidding and risk of an accident.</p> <ul style="list-style-type: none"> ► Drive on carefully. ► Visit a qualified specialist workshop immediately.
 <p>inoperative See Owner's Manual</p>	<p>ESP®, BAS, PRE-SAFE®, the HOLD function, hill start assist and ESP® trailer stabilisation are not available due to a malfunction. The adaptive brake lights, BAS PLUS, COLLISION PREVENTION ASSIST and PRE-SAFE® Brake may also have failed.</p> <p>In addition, the  and  warning lamps light up in the instrument cluster.</p> <p>The self-diagnosis function, for example, may not be complete. ATTENTION ASSIST is deactivated.</p> <p>⚠ WARNING</p> <p>The brake system continues to function normally, but without the functions listed above.</p> <p>The braking distance may thus increase in an emergency braking situation.</p> <p>If ESP® is not operational, ESP® is unable to stabilise the vehicle. There is an increased danger of skidding and risk of an accident.</p> <ul style="list-style-type: none"> ► Drive on carefully. ► Visit a qualified specialist workshop.

Display messages	Possible causes/consequences and ► Solutions
   <p data-bbox="115 276 308 331">inoperative See Owner's Manual</p>	<p data-bbox="370 177 1036 264">EBD (electronic brake force distribution), ABS, ESP[®], BAS, PRE-SAFE[®], the HOLD function, hill start assist and ESP[®] trailer stabilisation are unavailable due to a malfunction.</p> <p data-bbox="370 276 1013 331">The adaptive brake lights, BAS PLUS, COLLISION PREVENTION ASSIST and PRE-SAFE[®] Brake may also have failed.</p> <p data-bbox="370 343 1016 399">In addition, the ,  and  warning lamps light up in the instrument cluster and a warning tone sounds.</p> <p data-bbox="381 416 535 442">⚠ WARNING</p> <p data-bbox="370 459 1036 544">The brake system continues to function normally, but without the functions listed above. The front and rear wheels could therefore lock, for example, if you brake hard.</p> <p data-bbox="370 555 1036 635">The steerability and braking characteristics may be severely affected. The braking distance may increase in an emergency braking situation.</p> <p data-bbox="370 646 1036 710">If ESP[®] is not operational, ESP[®] is unable to stabilise the vehicle. There is an increased danger of skidding and risk of an accident.</p> <ul data-bbox="370 719 897 783" style="list-style-type: none"> ► Drive on carefully. ► Visit a qualified specialist workshop immediately.
 <p data-bbox="115 863 308 919">Release parking brake</p>	<p data-bbox="370 810 1036 866">You are driving with the parking brake applied. A warning tone also sounds.</p> <ul data-bbox="370 879 669 904" style="list-style-type: none"> ► Release the parking brake.
 <p data-bbox="115 992 333 1018">Brake immediately</p>	<p data-bbox="370 940 1008 995">A malfunction has occurred while the HOLD function is active. or</p> <p data-bbox="370 1007 812 1032">With the Hold function activated, you have:</p> <ul data-bbox="370 1050 946 1114" style="list-style-type: none"> • opened the driver's door and released the seat belt or • switched off the engine. <p data-bbox="370 1121 1036 1177">A tone may also sound at regular intervals. If you attempt to lock the vehicle, the tone becomes louder.</p> <p data-bbox="370 1185 661 1211">You cannot start the engine.</p> <ul data-bbox="370 1222 1036 1369" style="list-style-type: none"> ► Paying attention to the traffic situation, immediately depress the brake pedal firmly and hold until the display message disappears. ► Secure the vehicle against rolling away (► page 199). You can restart the engine.

Display messages	Possible causes/consequences and ► Solutions
 <p data-bbox="85 228 303 284">Check brake fluid level</p>	<p data-bbox="342 177 938 201">There is insufficient brake fluid in the brake fluid reservoir.</p> <p data-bbox="342 212 1003 268">In addition, the red  warning lamp lights up in the instrument cluster and a warning tone sounds.</p> <p data-bbox="353 288 505 312">▲ WARNING</p> <p data-bbox="342 328 748 352">The braking efficiency may be impaired.</p> <p data-bbox="342 363 642 387">There is a risk of an accident.</p> <ul style="list-style-type: none"> <li data-bbox="342 403 1003 483">► Pull over and stop the vehicle safely as soon as possible, paying attention to road and traffic conditions. Do not continue driving under any circumstances. <li data-bbox="342 496 908 520">► Secure the vehicle against rolling away (▷ page 199). <li data-bbox="342 531 770 555">► Consult a qualified specialist workshop. <li data-bbox="342 566 986 590">► Do not top up the brake fluid. This does not correct the fault.
 <p data-bbox="85 675 277 730">Check brake pad wear</p>	<p data-bbox="342 624 888 647">The brake pads/linings have reached their wear limit.</p> <ul style="list-style-type: none"> <li data-bbox="342 659 736 683">► Visit a qualified specialist workshop.
<p data-bbox="85 751 277 839">PRE-SAFE inoperative See Owner's Manual</p>	<p data-bbox="342 751 1003 807">Important functions of PRE-SAFE® have failed. All other occupant safety systems, e.g. airbags, remain available.</p> <ul style="list-style-type: none"> <li data-bbox="342 818 866 842">► Visit a qualified specialist workshop immediately.

Display messages	Possible causes/consequences and ► Solutions
<p>PRE-SAFE Functions currently limited See Owner's Manual</p>	<p>PRE-SAFE® brake or Adaptive Brake Assist of COLLISION PREVENTION ASSIST is temporarily not operational.</p> <p>Possible causes:</p> <ul style="list-style-type: none"> • the function is impaired due to heavy rain or snow. • the sensors in the radiator trim and in the bumpers are dirty. • the radar sensor system is temporarily inoperative, e.g. due to electromagnetic radiation emitted by nearby TV or radio stations or other sources of electromagnetic radiation. • AMG vehicles: ESP® is deactivated. • the system is outside the operating temperature range. • the on-board voltage is too low. <p>Once the causes listed above no longer apply, the display message goes out.</p> <p>PRE-SAFE® Brake is operational again.</p> <p>If the display message does not disappear:</p> <ul style="list-style-type: none"> ► Pull over and stop the vehicle safely as soon as possible, paying attention to road and traffic conditions. ► Secure the vehicle against rolling away (▷ page 199). ► Clean the sensors in the radiator grille and the bumper (▷ page 375). ► Restart the engine. ► AMG vehicles: reactivate ESP® (▷ page 79).
<p>PRE-SAFE Functions limited See Owner's Manual</p>	<p>PRE-SAFE® brake or Adaptive Brake Assist of COLLISION PREVENTION ASSIST is not available due to a malfunction. BAS PLUS or the distance warning signal may also have failed.</p> <ul style="list-style-type: none"> ► Visit a qualified specialist workshop.
	<p>If the symbol appears in the multifunction display, a seat belt tongue has been inserted into a rear seat belt buckle.</p> <p>Further information on the status indicator for the rear seat belts (▷ page 54).</p>



Display messages	Possible causes/consequences and ► Solutions
	<p>If the symbol appears in the multifunction display, a seat belt tongue has not been inserted in a rear seat belt buckle.</p> <p>⚠ WARNING</p> <p>A seat belt which is not worn correctly, or which has not been engaged in the seat belt buckle correctly, cannot provide the intended level of protection.</p> <p>This poses an increased risk of injury.</p> <p>► If necessary, ask the occupants in the rear to fasten their seat belts (▷ page 52).</p> <p>Further information on the status indicator for the rear seat belts (▷ page 54).</p>
 <p>Restraint sys. malfunction Consult workshop</p>	<p>There is a malfunction in the SRS (Supplemental Restraint System). The  warning lamp also lights up in the instrument cluster.</p> <p>⚠ WARNING</p> <p>The airbags or belt tensioners may either be triggered unintentionally or, in the event of an accident, may not be triggered.</p> <p>This poses an increased risk of injury.</p> <p>► Visit a qualified specialist workshop.</p> <p>For further information about the Supplemental Restraint System; see (▷ page 43).</p>
 <p>Front left malfunction Consult workshop or Front right malfunction Consult workshop</p>	<p>SRS has malfunctioned at the front on the left or right. The  warning lamp also lights up in the instrument cluster.</p> <p>⚠ WARNING</p> <p>The airbags or belt tensioners may either be triggered unintentionally or, in the event of an accident, may not be triggered.</p> <p>This poses an increased risk of injury.</p> <p>► Visit a qualified specialist workshop.</p>
 <p>Rear left malfunction Consult workshop or Rear right malfunction Consult workshop</p>	<p>⚠ WARNING</p> <p>The airbags or belt tensioners may either be triggered unintentionally or, in the event of an accident, may not be triggered.</p> <p>This poses an increased risk of injury.</p> <p>SRS has malfunctioned at the rear on the left or right. The  warning lamp also lights up in the instrument cluster.</p> <p>► Visit a qualified specialist workshop.</p>









Display messages	Possible causes/consequences and ► Solutions
 <p>Rear centre malfunction Consult workshop</p>	<p> WARNING</p> <p>The airbags or belt tensioners may either be triggered unintentionally or, in the event of an accident, may not be triggered. This poses an increased risk of injury.</p> <p>SRS has malfunctioned at the rear centre. The  warning lamp also lights up in the instrument cluster.</p> <p>► Visit a qualified specialist workshop.</p>
 <p>Left windowbag malfunction Consult workshop or Right windowbag malfunction Consult workshop</p>	<p>There is a malfunction in the left-hand and/or right-hand windowbag.</p> <p>The  warning lamp also lights up in the instrument cluster.</p> <p> WARNING</p> <p>The left or right windowbag may either be triggered unintentionally or, in the event of an accident, may not be triggered. This poses an increased risk of injury.</p> <p>► Visit a qualified specialist workshop.</p>

Lights



i Display messages about LEDs:



This display message will only appear if all the LEDs have failed.



Display messages	Possible causes/consequences and ► Solutions
 <p>Left cornering light or Right cornering light</p>	<p>The left or right-hand cornering light is faulty.</p> <p>► Visit a qualified specialist workshop.</p>
 <p>Left dipped beam or Right dipped beam</p>	<p>The left or right-hand dipped-beam headlamp is faulty.</p> <p>► Visit a qualified specialist workshop.</p>
 <p>Trailer left tail lamp or Trailer right tail lamp</p>	<p>The left or right-hand trailer tail lamp is faulty.</p> <p>► Observe the separate operating instructions provided by the trailer manufacturer.</p>









Display messages	Possible causes/consequences and ► Solutions
 Trailer left turn signal or Trailer right turn signal	<p>The left or right-hand trailer turn signal lamp is faulty.</p> <p>► Observe the separate operating instructions provided by the trailer manufacturer.</p>
 Trailer brake lamp	<p>The trailer brake lamp is faulty.</p> <p>► Observe the separate operating instructions provided by the trailer manufacturer.</p>
 Rear left turn signal or Rear right turn signal	<p>The rear left-hand or rear right-hand turn signal is faulty.</p> <p>► Visit a qualified specialist workshop.</p>
 Front left turn signal or Front right turn signal	<p>The front left-hand or front right-hand turn signal is faulty.</p> <p>► Check whether you are permitted to replace the bulb yourself (> page 148).</p> <p>or</p> <p>► Visit a qualified specialist workshop.</p>
 Left mirror turn signal or Right mirror turn signal	<p>The turn signal in the left-hand or right-hand exterior mirror is faulty.</p> <p>► Visit a qualified specialist workshop.</p>
 Third brake lamp	<p>The third brake lamp is faulty.</p> <p>► Visit a qualified specialist workshop.</p>
 Left-hand tail lamp/brake lamp or Right-hand tail lamp/brake lamp	<p>The left or right-hand tail lamp/brake lamp is faulty.</p> <p>► Visit a qualified specialist workshop.</p>
 Left main beam or Right main beam	<p>The left or right-hand main-beam headlamp is faulty.</p> <p>► Check whether you are permitted to replace the bulb yourself (> page 148).</p> <p>or</p> <p>► Visit a qualified specialist workshop.</p>



Display messages	Possible causes/consequences and ► Solutions
 Left licence plate lamp or Right licence plate lamp	<p>The left or right-hand licence plate lamp is faulty.</p> <p>► Visit a qualified specialist workshop.</p>
 Rear foglamp	<p>The rear foglamp is faulty.</p> <p>► Visit a qualified specialist workshop.</p>
 Front left parking lamp or Front right parking lamp	<p>The front left or front right parking lamp is faulty.</p> <p>► Visit a qualified specialist workshop.</p>
 Left revers. lamp or Right revers. lamp	<p>The left or right-hand reversing lamp is faulty.</p> <p>► Visit a qualified specialist workshop.</p>
 Rear left side marker lamp or Rear right side marker lamp	<p>The rear left or right side marker lamp is faulty.</p> <p>► Visit a qualified specialist workshop.</p>
 Left daytime driving lamp or Right daytime driving lamp	<p>The left-hand or right-hand daytime driving lamp is faulty.</p> <p>► Visit a qualified specialist workshop.</p>
 Intell. Light System inoperative	<p>The Intelligent Light System is faulty. The lights remain available without the Intelligent Light System.</p> <p>► Visit a qualified specialist workshop.</p>
 Malfunction See Owner's Manual	<p>The exterior lighting is faulty.</p> <p>► Visit a qualified specialist workshop.</p>

Display messages	Possible causes/consequences and ► Solutions
	<p>Vehicles with trailer tow hitch: a fuse may have blown.</p> <ul style="list-style-type: none"> ► Check the fuses (▷ page 399). ► If necessary, replace the blown fuse. Observe the warning notes as you do so. <p>If the display message continues to be displayed:</p> <ul style="list-style-type: none"> ► Visit a qualified specialist workshop.
 <p>AUTO lights inoperative</p>	<p>The light sensor is faulty.</p> <ul style="list-style-type: none"> ► Visit a qualified specialist workshop.
 <p>Switch off lights</p>	<p>The lights are still switched on when you leave the vehicle. A warning tone also sounds.</p> <ul style="list-style-type: none"> ► Turn the light switch to AUTO.
<p>Adaptive Main-beam Assist currently unavailable See Owner's Manual or Adaptive Highbeam Assist Plus currently unavailable See Owner's Manual</p>	<p>Adaptive Highbeam Assist or Adaptive Highbeam Assist Plus is deactivated and temporarily not operational. Possible causes:</p> <ul style="list-style-type: none"> • the windscreen is dirty in the camera's field of vision. • visibility is impaired due to heavy rain, snow or fog. <ul style="list-style-type: none"> ► Clean the windscreen. <p>If the system detects that the camera is fully operational again, the Adaptive Main-beam Assist available again or Adaptive Highbeam Assist Plus available again message is displayed.</p> <p>Adaptive Highbeam Assist or Adaptive Highbeam Assist Plus is operational again.</p>
<p>Adaptive Main-beam Assist inoperative or Adaptive Highbeam Assist Plus inoperative</p>	<p>Adaptive Highbeam Assist or Adaptive Highbeam Assist Plus is faulty.</p> <ul style="list-style-type: none"> ► Visit a qualified specialist workshop.









Engine	
Display messages	Possible causes/consequences and ► Solutions
 <p>Top up coolant See Owner's Manual</p>	<p>The coolant level is too low.</p> <p>! Avoid making long journeys with too little coolant in the engine cooling system. The engine will otherwise be damaged.</p> <ul style="list-style-type: none"> ► Top up the coolant, observing the warning notes before doing so (► page 368). ► If the coolant needs topping up more often than usual, have the engine coolant system checked at a qualified specialist workshop.
	<p>The fan motor is faulty.</p> <ul style="list-style-type: none"> ► If the coolant temperature is below 120 °C, you can continue driving to the nearest qualified specialist workshop. ► Avoid heavy loads on the engine as you do so, e.g. driving in mountainous terrain and stop-start traffic.
 <p>Coolant Stop vehicle Switch engine off</p>	<p>The coolant is too hot. A warning tone also sounds.</p> <p>⚠ WARNING</p> <p>Never drive with an overheated engine. Driving when your engine is overheated can cause some fluids which may have leaked into the engine compartment to catch fire.</p> <p>Steam from an overheated engine can cause serious burns, which can occur just by opening the bonnet.</p> <p>There is a risk of injury.</p> <ul style="list-style-type: none"> ► Stop the vehicle immediately, paying attention to road and traffic conditions, and switch off the engine. ► Secure the vehicle against rolling away (► page 199). ► Wait until the engine has cooled down. ► Make sure that the air supply to the engine radiator is not blocked, e.g. by frozen slush. ► Do not start the engine again until the display message goes out and the coolant temperature is below 120 °C. The engine may otherwise be damaged. ► Pay attention to the coolant temperature display. ► If the temperature increases again, visit a qualified specialist workshop immediately. <p>Under normal operating conditions and with the specified coolant level, the coolant temperature may rise to 120 °C.</p>

Display messages	Possible causes/consequences and ► Solutions
	<p>The battery is not being charged. A warning tone also sounds.</p> <p>Possible causes:</p> <ul style="list-style-type: none"> • faulty alternator • torn poly-V-belt • a malfunction in the electronics <p>► Stop the vehicle immediately, paying attention to road and traffic conditions, and switch off the engine.</p> <p>► Secure the vehicle against rolling away (▷ page 199).</p> <p>► Open the bonnet.</p> <p>► Check whether the poly-V-belt is torn.</p> <p>If the poly-V-belt is torn:</p> <p>! Do not continue driving. The engine could otherwise overheat.</p> <p>► Consult a qualified specialist workshop.</p> <p>If the poly-V-belt is OK:</p> <p>► Visit a qualified specialist workshop.</p>
 <p>Check eng. oil lev. when next refuelling</p>	<p>The engine oil level has dropped to the minimum level. A warning tone also sounds.</p> <p>► Check the oil level when next refuelling, at the latest (▷ page 367).</p> <p>► If necessary, top up the engine oil (▷ page 367).</p> <p>► Have the engine checked at a qualified specialist workshop if the engine oil needs topping up more often than usual.</p> <p>Information on approved engine oils can be obtained from any qualified specialist workshop or on the Internet at http://bevo.mercedes-benz.com.</p>
 <p>Add 1 litre engine oil when next refuelling</p>	<p>AMG vehicles: the engine oil level is too low.</p> <p>► Check the oil level when next refuelling, at the latest (▷ page 367).</p> <p>► If necessary, top up the engine oil (▷ page 367).</p> <p>► Have the engine checked at a qualified specialist workshop if the engine oil needs topping up more often than usual.</p> <p>Information on approved engine oils can be obtained from any qualified specialist workshop or on the Internet at http://bevo.mercedes-benz.com.</p>

Display messages	Possible causes/consequences and ► Solutions
 Reserve fuel level	<p>The fuel level has dropped into the reserve range. Operation of the auxiliary heating is deactivated if the fuel level drops into the reserve range.</p> <p>► Refuel at the nearest filling station.</p>
	<p>There is very little fuel in the fuel tank. The auxiliary heating cannot be operated.</p> <p>► Refuel at the nearest filling station without fail.</p>
 Please replace air filter	<p>Vehicles with a diesel engine: the engine air filter is dirty and must be replaced.</p> <p>► Visit a qualified specialist workshop.</p>
 Clean the fuel filter	<p>Vehicles with a diesel engine: there is water in the fuel filter. The water must be drained off.</p> <p>► Visit a qualified specialist workshop.</p>
 Refill AdBlue at workshop See Owner's Manual	<p>The AdBlue® level has fallen below the reserve range. A warning tone also sounds.</p> <p>► Have AdBlue® refilled as soon as possible at a qualified specialist workshop.</p>
 Refill AdBlue at workshop No start in .. km	<p>The AdBlue® level is only sufficient for the indicated distance. A warning tone also sounds.</p> <p>► Have AdBlue® refilled as soon as possible at a qualified specialist workshop.</p>
 Refill AdBlue at workshop Eng. start not possible	<p>The AdBlue® tank is empty. A warning tone also sounds. You can no longer start the engine.</p> <p>► Consult a qualified specialist workshop immediately.</p>
 Check AdBlue See Owner's Manual	<p>The AdBlue® system is malfunctioning. A warning tone also sounds.</p> <p>► Visit a qualified specialist workshop.</p>



Display messages	Possible causes/consequences and ► Solutions
 Eng. start not possible in ..km	The AdBlue® system is malfunctioning. A warning tone also sounds. ► Visit a qualified specialist workshop immediately.
 Eng. start not possible	The AdBlue® system is malfunctioning. A warning tone also sounds. You can no longer start the engine. ► Consult a qualified specialist workshop immediately.

Driving systems

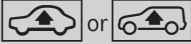
Display messages	Possible causes/consequences and ► Solutions
 Attention Assist: Take a break!	Based on certain criteria, ATTENTION ASSIST has detected fatigue or a lack of concentration on the part of the driver. A warning tone also sounds. ► If necessary, take a break. During long journeys, take regular breaks in good time so that you get enough rest.
 Attention Assist inoperative	ATTENTION ASSIST is inoperative. ► Visit a qualified specialist workshop.
 or  Vehicle rising	Your vehicle is adjusting to the level you have selected.
 or  Vehicle rising Please wait	The vehicle level is too low when the vehicle is stationary. A warning tone also sounds. ► Do not pull away. The vehicle level is set when the display message disappears.
 or  Stop vehicle Vehicle too low	You have pulled away while the vehicle level is still too low. AIRMATIC sets the vehicle to the selected level after a short period. ► Pull over and stop the vehicle safely as soon as possible, paying attention to road and traffic conditions. ► Secure the vehicle against rolling away (► page 199). ► Wait until the display message disappears before pulling away.

Display messages	Possible causes/consequences and ► Solutions
	<p>AIRMATIC is faulty. A warning tone also sounds.</p> <ul style="list-style-type: none"> ► Do not drive at speeds above 80 km/h. ► Make only slight steering movements. Otherwise, the front wings or the tyres could be damaged if the steering movement is too great. ► Listen for scraping sounds. ► Pull over and stop the vehicle safely, paying attention to road and traffic conditions, and select a higher vehicle level. Depending on the malfunction, it may be possible to raise the vehicle. ► Visit a qualified specialist workshop.
 <p>Malfunction</p>	<p>The AIRMATIC function is restricted. The vehicle's handling characteristics may be affected.</p> <ul style="list-style-type: none"> ► Do not drive at speeds above 80 km/h. ► Visit a qualified specialist workshop.
<p>Traffic Sign Assist currently unavailable See Owner's Manual</p>	<p>Traffic Sign Assist is deactivated and temporarily inoperative. Possible causes:</p> <ul style="list-style-type: none"> • the windscreen is dirty in the camera's field of vision. • visibility is impaired due to heavy rain, snow or fog. <p>► Clean the windscreen.</p> <p>If the system detects that the camera is fully operational, the display message disappears.</p> <p>Traffic Sign Assist is operational again.</p>
<p>Traffic Sign Assist inoperative</p>	<p>Traffic Sign Assist is faulty.</p> <ul style="list-style-type: none"> ► Visit a qualified specialist workshop.
<p>HOLD Off</p>	<p>The HOLD function is deactivated. The vehicle is skidding. A warning tone also sounds.</p> <ul style="list-style-type: none"> ► Reactivate the HOLD function later (► page 221). <p>The HOLD function is deactivated. When the brake pedal is firmly depressed, an activation condition is not fulfilled. A warning tone also sounds.</p> <ul style="list-style-type: none"> ► Check the activation conditions for the HOLD function (► page 221).

Display messages	Possible causes/consequences and ► Solutions
<p>Lane Keeping Assist currently unavailable See Owner's Manual or Active Lane Keeping Assist currently unavailable See Owner's Manual</p>	<p>Lane Keeping Assist or Active Lane Keeping Assist is deactivated and temporarily inoperative. Possible causes:</p> <ul style="list-style-type: none"> • the windscreen is dirty in the camera's field of vision. • visibility is impaired due to heavy rain, snow or fog. • there are no lane markings for a longer period. • the lane markings are worn, dark or covered, e.g. by dirt or snow. <p>Once the causes listed above no longer apply, the display message goes out.</p> <p>Lane Keeping Assist or Active Lane Keeping Assist is operational again.</p> <p>If the display message does not disappear:</p> <ul style="list-style-type: none"> ► Pull over and stop the vehicle safely as soon as possible, paying attention to road and traffic conditions. ► Secure the vehicle against rolling away (▷ page 199). ► Clean the windscreen.
<p>Lane Keeping Assist inoperative or Active Lane Keeping Assist inoperative</p>	<p>Lane Keeping Assist or Active Lane Keeping Assist is faulty.</p> <ul style="list-style-type: none"> ► Visit a qualified specialist workshop.

Display messages	Possible causes/consequences and ► Solutions
<p>Blind Spot Assist currently unavailable See Owner's Manual or Active Blind Spot Assist currently unavailable See Owner's Manual</p>	<p>Blind Spot Assist or Active Blind Spot Assist is temporarily inoperative. Possible causes:</p> <ul style="list-style-type: none"> • the sensors are dirty. • the function is impaired due to heavy rain or snow. • the radar sensor system is outside the operating temperature range. • the radar sensor system is temporarily inoperative, e.g. due to electromagnetic radiation emitted by nearby TV or radio stations or other sources of electromagnetic radiation. <p>The yellow  indicator lamps also light up in the exterior mirrors.</p> <p>Once the causes listed above no longer apply, the display message goes out.</p> <p>Blind Spot Assist or Active Blind Spot Assist is operational again.</p> <p>If the display message does not disappear:</p> <ul style="list-style-type: none"> ► Pull over and stop the vehicle safely as soon as possible, paying attention to road and traffic conditions. ► Secure the vehicle against rolling away (▷ page 199). ► Clean the sensors (▷ page 375). ► Restart the engine. <p>Blind Spot Assist or Active Blind Spot Assist is deactivated while towing a trailer.</p> <p>You have established the electrical connection between the trailer and your vehicle.</p> <ul style="list-style-type: none"> ► Press  on the steering wheel to confirm the display message.
<p>Blind Spot Assist inoperative or Active Blind Spot Assist inoperative</p>	<p>Blind Spot Assist or Active Blind Spot Assist is faulty.</p> <p>The yellow  indicator lamps also light up in the exterior mirrors.</p> <ul style="list-style-type: none"> ► Visit a qualified specialist workshop.
<p>Park Assist cancelled</p>	<p>The driver's door is open and the driver's seat belt has not been fastened.</p> <ul style="list-style-type: none"> ► Repeat the parking process with the seat belt fastened and the driver's door closed.



Display messages	Possible causes/consequences and ► Solutions
	<p>You inadvertently touched the multifunction steering wheel while steering intervention was active.</p> <ul style="list-style-type: none"> ► While steering intervention is active, make sure not to touch the multifunction steering wheel.
	<p>The vehicle has started to skid and ESP® has intervened.</p> <ul style="list-style-type: none"> ► Use Active Parking Assist again later (▷ page 232).
Park Assist inoperative	<p>You have just carried out a large number of turning or parking manoeuvres.</p> <p>Active Parking Assist will become available again after approximately ten minutes (▷ page 232).</p> <ul style="list-style-type: none"> ► Pull over and stop the vehicle safely as soon as possible, paying attention to road and traffic conditions. ► Switch off and restart the engine. <p>If the display message continues to be displayed:</p> <ul style="list-style-type: none"> ► Visit a qualified specialist workshop.
	<p>PARKTRONIC is faulty.</p> <ul style="list-style-type: none"> ► Visit a qualified specialist workshop.
Park Assist switched off	<p>The vehicle is parked. A warning tone also sounds.</p> <p>The display message disappears automatically.</p>
DISTRONIC PLUS off	<p>DISTRONIC PLUS has been deactivated (▷ page 211).</p> <p>If it was not deactivated by the driver, a warning tone also sounds.</p>
DISTRONIC PLUS available again	<p>DISTRONIC PLUS is operational again after having been temporarily unavailable. You can now reactivate DISTRONIC PLUS (▷ page 211).</p>

Display messages	Possible causes/consequences and ► Solutions
<p>DISTRONIC PLUS currently unavailable See Owner's Manual</p>	<p>DISTRONIC PLUS is temporarily inoperative. DISTRONIC PLUS Steering Assist is also temporarily inoperative. Possible causes:</p> <ul style="list-style-type: none"> • the function is impaired due to heavy rain or snow. • the sensors in the radiator trim and in the bumpers are dirty. • the radar sensor system is temporarily inoperative, e.g. due to electromagnetic radiation emitted by nearby TV or radio stations or other sources of electromagnetic radiation. • the system is outside the operating temperature range. • the on-board voltage is too low. <p>A warning tone also sounds. Once the causes listed above no longer apply, the display message goes out. DISTRONIC is operational again. If the display message does not disappear:</p> <ul style="list-style-type: none"> ► Pull over and stop the vehicle safely as soon as possible, paying attention to road and traffic conditions. ► Secure the vehicle against rolling away (▷ page 199). ► Clean the sensors in the radiator grille and the bumper (▷ page 375). ► Restart the engine.
<p>DISTRONIC PLUS inoperative</p>	<p>DISTRONIC PLUS is faulty. BAS PLUS and PRE-SAFE® Brake may also have failed. The following may have also failed:</p> <ul style="list-style-type: none"> • BAS PLUS • PRE-SAFE® Brake • DISTRONIC PLUS Steering Assist <p>A warning tone also sounds.</p> <ul style="list-style-type: none"> ► Visit a qualified specialist workshop.
<p>DISTRONIC PLUS suspended</p>	<p>You have depressed the accelerator pedal. DISTRONIC PLUS is no longer controlling the speed of the vehicle.</p> <ul style="list-style-type: none"> ► Remove your foot from the accelerator pedal.
<p>DISTRONIC PLUS - - - km/h</p>	<p>An activation condition for DISTRONIC PLUS is not fulfilled.</p> <ul style="list-style-type: none"> ► Check the activation conditions for DISTRONIC PLUS (▷ page 211).

Display messages	Possible causes/consequences and ► Solutions
DISTRONIC PLUS and SPEEDTRONIC inoperative	DISTRONIC PLUS and SPEEDTRONIC are faulty. DISTRONIC PLUS Steering Assist is therefore unavailable. A warning tone also sounds. ► Visit a qualified specialist workshop.
DTR+: steering assist. currently unavailable See Owner's Manual	DISTRONIC PLUS Steering Assist is temporarily inoperative. Possible causes: <ul style="list-style-type: none"> • the windscreen is dirty in the camera's field of vision. • visibility is impaired due to heavy rain, snow or fog. • there are no lane markings for a longer period. • the lane markings are worn, dark or covered, e.g. by dirt or snow. Once the causes listed above no longer apply, the display message goes out. DISTRONIC PLUS Steering Assist is operational again. If the display message does not disappear: <ul style="list-style-type: none"> ► Pull over and stop the vehicle safely as soon as possible, paying attention to road and traffic conditions. ► Secure the vehicle against rolling away (▷ page 199). ► Clean the windscreen.
DTR+: steering assistant inoperative	DISTRONIC PLUS Steering Assist is faulty. However, the DISTRONIC PLUS functions are still available. A warning tone also sounds. ► Visit a qualified specialist workshop.
Cruise control and SPEEDTRONIC inoperative	SPEEDTRONIC and cruise control are malfunctioning. A warning tone also sounds. ► Visit a qualified specialist workshop.
Limit --- km/h	While depressing the accelerator pedal beyond the pressure point (kickdown), SPEEDTRONIC cannot be activated.

Display messages	Possible causes/consequences and ► Solutions
Cruise control - - - km/h	<p>A condition for activating cruise control has not been met. You have tried to store a speed below 30 km/h, for example.</p> <ul style="list-style-type: none">► If conditions permit, drive faster than 30 km/h and store the speed.► Check the activation conditions for cruise control (► page 205).
120 km/h Maximum speed exceeded	<p>Only for certain countries: the maximum speed has been exceeded.</p> <p>In addition, the multifunction display shows 120 km/h!.</p> <ul style="list-style-type: none">► Drive more slowly.





Tyres	
Display messages	Possible causes/consequences and ► Solutions
Tyre pressure Check tyres	<p>The tyre pressure loss warning system has detected a significant loss in pressure.</p> <p>A warning tone also sounds.</p> <p> WARNING</p> <p>With tyre pressures which are too low, there is a risk of the following hazards:</p> <ul style="list-style-type: none"> • the tyres may burst, especially as the load and vehicle speed increase. • the tyres may wear excessively and/or unevenly, which may greatly impair tyre traction. • the driving characteristics, as well as steering and braking, may be greatly impaired. <p>There is a risk of an accident.</p> <ul style="list-style-type: none"> ► Stop the vehicle without making any sudden steering or braking manoeuvres. Pay attention to the traffic conditions as you do so. ► Secure the vehicle against rolling away (▷ page 199). ► Check the tyres and, if necessary, follow the instructions for a flat tyre (▷ page 385). ► Check the tyre pressures and, if necessary, correct the tyre pressure. ► Restart the tyre pressure loss warning system when the tyre pressure is correct (▷ page 410).
Run Flat Indicator then restart Run Flat Indicator	<p>The tyre pressure loss warning system generated a display message and has not been restarted since.</p> <ul style="list-style-type: none"> ► Set the correct tyre pressure in all four tyres. ► Restart the tyre pressure loss warning system (▷ page 410).
Run Flat Indicator Inoperative	<p>The tyre pressure loss warning system is faulty.</p> <ul style="list-style-type: none"> ► Visit a qualified specialist workshop.
Rectify tyre pressure	<p>The tyre pressure is too low in at least one of the tyres, or the tyre pressure difference between the wheels is too great.</p> <ul style="list-style-type: none"> ► Check the tyre pressures at the next opportunity (▷ page 410). ► If necessary, correct the tyre pressure. ► Restart the tyre pressure monitor (▷ page 412).





Display messages	Possible causes/consequences and ► Solutions
<p>Check tyre(s)</p>	<p>The tyre pressure in one or more tyres has dropped significantly. The wheel position is displayed in the multifunction display. A warning tone also sounds.</p> <p> WARNING</p> <p>With tyre pressures which are too low, there is a risk of the following hazards:</p> <ul style="list-style-type: none"> • the tyres may burst, especially as the load and vehicle speed increase. • the tyres may wear excessively and/or unevenly, which may greatly impair tyre traction. • the driving characteristics, as well as steering and braking, may be greatly impaired. <p>There is a risk of an accident.</p> <ul style="list-style-type: none"> ► Stop the vehicle without making any sudden steering or braking manoeuvres. Pay attention to the traffic conditions as you do so. ► Secure the vehicle against rolling away (▷ page 199). ► Check the tyres and, if necessary, follow the instructions for a flat tyre (▷ page 385). ► Check the tyre pressure (▷ page 410). ► If necessary, correct the tyre pressure.
<p>Warning tyre defect</p>	<p>The tyre pressure in one or more tyres has dropped suddenly. The wheel position is displayed in the multifunction display.</p> <p> WARNING</p> <p>If you drive with a flat tyre, there is a risk of the following hazards:</p> <ul style="list-style-type: none"> • a flat tyre affects the ability to steer or brake the vehicle. • you could lose control of the vehicle. • continued driving with a flat tyre will cause excessive heat build-up and possibly a fire. <p>There is a risk of an accident.</p> <ul style="list-style-type: none"> ► Stop the vehicle without making any sudden steering or braking manoeuvres. Pay attention to the traffic conditions as you do so. ► Secure the vehicle against rolling away (▷ page 199). ► Check the tyres and, if necessary, follow the instructions for a flat tyre (▷ page 385).



Display messages	Possible causes/consequences and ► Solutions
Tyre press. monitor currently unavailable	<p>Due to a source of radio interference, no signals can be received from the wheel sensors. The tyre pressure monitor is temporarily malfunctioning.</p> <p>► Drive on. The tyre pressure monitor restarts automatically as soon as the cause has been rectified.</p>
Wheel sensor(s) missing	<p>There is no signal from the tyre pressure sensor of one or several wheels. The pressure of the affected tyre is not displayed in the multifunction display.</p> <p>► Have the faulty tyre pressure sensor replaced at a qualified specialist workshop.</p>
Tyre press. monitor inoperative No wheel sensors	<p>The wheels fitted do not have a suitable tyre pressure sensor. The tyre pressure monitor is deactivated.</p> <p>► Fit wheels with suitable tyre pressure sensors. The tyre pressure monitor is activated automatically after driving for a few minutes.</p>
Tyre pressure monitor Inoperative	<p>The tyre pressure monitor is faulty.</p> <p>► Visit a qualified specialist workshop.</p>

Vehicle



Display messages	Possible causes/consequences and ► Solutions
Apply brake to deselect Park (P) position	<p>You have attempted to move the transmission selector lever to position D, R or N without depressing the brake pedal.</p> <p>► Depress the brake pedal.</p>
Risk of vehicle rolling Transmission not in P	<p>The driver's door is open and the transmission is in position R, N or D.</p> <p>A warning tone also sounds.</p> <p>► Shift the transmission to position P.</p> <p>► Secure the vehicle against rolling away (▷ page 199).</p>





Display messages	Possible causes/consequences and ► Solutions
Without changing gear, consult workshop	<p>You cannot change the transmission position due to a malfunction. A warning tone also sounds.</p> <p>If transmission position D is selected:</p> <ul style="list-style-type: none"> ► Drive to a qualified specialist workshop without shifting the transmission from position D. <p>If transmission position R, N or P is selected:</p> <ul style="list-style-type: none"> ► Consult a qualified specialist workshop.
Only select Park (P) when vehicle is stationary	<p>The vehicle is moving.</p> <ul style="list-style-type: none"> ► Pull over and stop the vehicle safely as soon as possible, paying attention to road and traffic conditions. ► Shift the transmission to position P.
	<p>Saloon: the boot lid is open.</p> <ul style="list-style-type: none"> ► Close the boot lid.
	<p>Estate: the tailgate is open.</p> <p>⚠ WARNING</p> <p>When the engine is running, exhaust gases can enter the vehicle interior if the tailgate is open.</p> <p>There is a risk of poisoning.</p> <ul style="list-style-type: none"> ► Close the tailgate.
 or 	<p>The bonnet is open. A warning tone also sounds.</p> <p>⚠ WARNING</p> <p>The open bonnet may then block your view when the vehicle is in motion.</p> <p>There is a risk of an accident.</p> <ul style="list-style-type: none"> ► Pull over and stop the vehicle safely as soon as possible, paying attention to road and traffic conditions. ► Secure the vehicle against rolling away (► page 199). ► Close the bonnet.
Active bonnet malfunction See Owner's Manual	<p>The active bonnet (pedestrian protection) is not active due to a malfunction or because it has already been triggered.</p> <ul style="list-style-type: none"> ► Visit a qualified specialist workshop.
	<p>At least one door is open. A warning tone also sounds.</p> <ul style="list-style-type: none"> ► Close all doors.

Display messages	Possible causes/consequences and ► Solutions
 <p>Rear left seat backrest not locked or Rear right seat backrest not locked</p>	<p>Saloon with through-loading feature in the rear bench seat: The backrest in the rear is not engaged on the left-hand and/or right-hand side. A warning tone also sounds.</p> <ul style="list-style-type: none"> ► Push the backrest back until it engages.
 <p>Check trailer hitch lock</p>	<p>The trailer tow hitch is not correctly engaged. A warning tone also sounds.</p> <ul style="list-style-type: none"> ► Stop the vehicle immediately, paying attention to road and traffic conditions, and switch off the engine. ► Apply the parking brake. ► Engage the trailer coupling's ball coupling in the end position (► page 261).
 <p>inoperative Battery low</p>	<p>The on-board voltage is too low. The auxiliary heating has switched itself off or cannot be switched on (► page 168).</p> <ul style="list-style-type: none"> ► Drive for a longer distance. The battery is being charged. The auxiliary heating is operational again as soon as the on-board electrical system voltage is sufficient.
 <p>inoperative Refuel vehicle</p>	<p>There is too little fuel in the fuel tank. The auxiliary heating cannot be switched on (► page 168).</p> <ul style="list-style-type: none"> ► Refuel at the nearest filling station.
 <p>inoperative See Owner's Manual</p>	<p>The auxiliary heating has a temporary malfunction or is faulty.</p> <ul style="list-style-type: none"> ► When the vehicle is on a level surface and the engine has cooled down, make up to four attempts to switch on the auxiliary heating, waiting several minutes between each attempt (► page 168). ► If the auxiliary heating does not switch on, consult a qualified specialist workshop.

Display messages	Possible causes/consequences and ► Solutions
 <p>Power steering mal- function See Own- er's Manual</p>	<p>The power steering assistance is faulty. A warning tone also sounds.</p> <p> WARNING</p> <p>You will need to use more force to steer. There is a risk of an accident.</p> <ul style="list-style-type: none"> ► Check whether you are able to apply the extra force required. ► If you are able to steer safely: carefully drive on to a qualified specialist workshop. ► If you are unable to steer safely: do not drive on. Contact the nearest qualified specialist workshop.
<p>Telephone No service</p>	<p>Your vehicle is outside the network provider's transmitter/ receiver range.</p> <ul style="list-style-type: none"> ► Wait until the mobile phone operational readiness symbol appears in the multifunction display.
 <p>Top up washer fluid</p>	<p>The washer fluid level in the washer fluid reservoir has dropped below the minimum.</p> <ul style="list-style-type: none"> ► Top up the washer fluid (► page 369).

Key





Display messages	Possible causes/consequences and ► Solutions
 <p>Key does not belong to vehicle</p>	<p>You have put the wrong key in the ignition lock.</p> <ul style="list-style-type: none"> ► Use the correct key.
 <p>Replace key</p>	<p>The key needs to be replaced.</p> <ul style="list-style-type: none"> ► Visit a qualified specialist workshop.
 <p>Change key batter- ies</p>	<p>The batteries of the KEYLESS-GO key are discharged.</p> <ul style="list-style-type: none"> ► Change the batteries (► page 92).

Display messages	Possible causes/consequences and ► Solutions
 <p>Key not detected (red display message)</p>	<p>The KEYLESS-GO key is not in the vehicle. A warning tone also sounds. If the engine is switched off, you can no longer lock the vehicle centrally or start the engine.</p> <ul style="list-style-type: none"> ► Pull over and stop the vehicle safely as soon as possible, paying attention to road and traffic conditions. ► Secure the vehicle against rolling away (▷ page 199). ► Locate the KEYLESS-GO key. <p>The KEYLESS-GO key is not detected while the engine is running because there is interference from a strong source of radio waves. A warning tone also sounds.</p> <ul style="list-style-type: none"> ► Pull over and stop the vehicle safely as soon as possible, paying attention to road and traffic conditions. ► Secure the vehicle against rolling away (▷ page 199). ► Operate the vehicle with the key in the ignition lock if necessary.
 <p>Key not detected (white display message)</p>	<p>The KEYLESS-GO key cannot be detected at present.</p> <ul style="list-style-type: none"> ► Change the location of the key with the KEYLESS-GO functions in the vehicle. <p>If the KEYLESS-GO key is still not detected:</p> <ul style="list-style-type: none"> ► Operate the vehicle with the key in the ignition lock if necessary.
 <p>Key still in vehicle</p>	<p>The KEYLESS-GO key has been detected inside the vehicle during locking.</p> <ul style="list-style-type: none"> ► Remove the KEYLESS-GO key from the vehicle.
 <p>Remove starting button, then insert key</p>	<p>The KEYLESS-GO key is not continually detected. KEYLESS-GO is temporarily malfunctioning or is defective. A warning tone also sounds.</p> <ul style="list-style-type: none"> ► Insert the key into the ignition lock and turn it to the desired position. ► Visit a qualified specialist workshop.
 <p>Close doors to lock vehicle</p>	<p>At least one door is open. A warning tone also sounds.</p> <ul style="list-style-type: none"> ► Close all doors and lock the vehicle again.





Warning and indicator lamps in the instrument cluster





Safety







Seat belts





Problem	Possible causes/consequences and ► Solutions
 <p>Only for certain countries: the red seat belt warning lamp lights up for six seconds after the engine starts.</p>	<p>The seat belt warning lamp reminds the driver and front passenger to fasten their seat belts.</p> <ul style="list-style-type: none"> ► Fasten your seat belt (▷ page 52).
 <p>Only for certain countries: the red seat belt warning lamp lights up after the engine starts. In addition, a warning tone sounds for up to six seconds.</p>	<p>The driver's seat belt is not fastened.</p> <ul style="list-style-type: none"> ► Fasten your seat belt (▷ page 52). The warning tone ceases.
 <p>The red seat belt warning lamp lights up after the engine starts, as soon as the driver's or the front-passenger door is closed.</p>	<p>The driver or front passenger has not fastened their seat belt.</p> <ul style="list-style-type: none"> ► Fasten your seat belt (▷ page 52). The warning lamp goes out.
	<p>There are objects on the front-passenger seat.</p> <ul style="list-style-type: none"> ► Remove the objects from the front-passenger seat and stow them in a secure place. The warning lamp goes out.
 <p>The red seat belt warning lamp flashes and an intermittent audible warning sounds.</p>	<p>The driver or passenger has not fastened their seat belt. At the same time, the car is being driven faster than 25 km/h or has been briefly driven faster than 25 km/h.</p> <ul style="list-style-type: none"> ► Fasten your seat belt (▷ page 52). The warning lamp goes out and the intermittent warning tone ceases.
	<p>There are objects on the front-passenger seat. At the same time, you are driving faster than 25 km/h or have briefly driven faster than 25 km/h.</p> <ul style="list-style-type: none"> ► Remove the objects from the front-passenger seat and stow them in a secure place. The warning lamp goes out and the intermittent warning tone ceases.





Safety systems



Problem	Possible causes/consequences and ► Solutions
 <p>The yellow brake system warning lamp lights up while the engine is running.</p>	<p> WARNING</p> <p>The brake system is malfunctioning and the braking characteristics may be affected.</p> <p>There is a risk of an accident.</p> <ul style="list-style-type: none"> ► If the multifunction display shows a display message, please observe this. ► Drive on carefully. ► Visit a qualified specialist workshop.
 <p>The red brake system warning lamp comes on while the vehicle is moving. A warning tone also sounds.</p>	<p>You are driving with the parking brake applied.</p> <ul style="list-style-type: none"> ► Release the parking brake. The warning lamp goes out and the warning tone ceases.
 <p>The red brake system warning lamp is lit while the engine is running. A warning tone also sounds.</p>	<p> WARNING</p> <p>The brake boosting effect is malfunctioning and the braking characteristics may be affected.</p> <p>There is a risk of an accident.</p> <ul style="list-style-type: none"> ► Pull over and stop the vehicle safely as soon as possible, paying attention to road and traffic conditions. Do not continue driving under any circumstances. ► Secure the vehicle against rolling away (▷ page 199). ► Consult a qualified specialist workshop. ► Observe the additional display messages in the multifunction display.



Problem	Possible causes/consequences and ► Solutions
 <p>The red brake system warning lamp is lit while the engine is running. A warning tone also sounds.</p>	<p>There is insufficient brake fluid in the brake fluid reservoir.</p> <p> WARNING</p> <p>The braking efficiency may be impaired. There is a risk of an accident.</p> <ul style="list-style-type: none"> ► Pull over and stop the vehicle safely as soon as possible, paying attention to road and traffic conditions. Do not continue driving under any circumstances. ► Secure the vehicle against rolling away (▷ page 199). ► Do not top up the brake fluid. Topping up will not rectify the fault. ► Consult a qualified specialist workshop. ► Observe the additional display messages in the multifunction display.
 <p>The yellow ABS warning lamp is lit while the engine is running.</p>	<p>ABS (Anti-lock Brake System) has been deactivated due to a fault. Therefore, BAS (Brake Assist), BAS PLUS, COLLISION PREVENTION ASSIST, ESP® (Electronic Stability Program), PRE-SAFE®, PRE-SAFE® Brake, the HOLD function, hill start assist, ESP® trailer stabilisation and the adaptive brake lights, for example, are also deactivated.</p> <p>ATTENTION ASSIST is deactivated.</p> <p> WARNING</p> <p>The brake system continues to function normally, but without the functions listed above. The wheels could therefore lock if you brake hard, for example.</p> <p>The steerability and braking characteristics may be severely affected. The braking distance may increase in an emergency braking situation.</p> <p>If ESP® is not operational, ESP® is unable to stabilise the vehicle. There is an increased danger of skidding and risk of an accident.</p> <ul style="list-style-type: none"> ► Observe the additional display messages in the multifunction display. ► Drive on carefully. ► Visit a qualified specialist workshop. <p>If the ABS control unit is faulty, there is also a possibility that other systems, such as the navigation system or the automatic transmission, will be unavailable.</p>

Problem	Possible causes/consequences and ► Solutions
 <p>The yellow ABS warning lamp is lit while the engine is running. A warning tone also sounds.</p>	<p>EBD is unavailable due to a malfunction. Therefore, ABS, BAS, BAS PLUS, COLLISION PREVENTION ASSIST, ESP[®], PRE-SAFE[®], PRE-SAFE[®] Brake, the HOLD function, hill start assist, ESP[®] trailer stabilisation and the adaptive brake lights, for example, are also unavailable.</p> <p>ATTENTION ASSIST is deactivated.</p> <p> WARNING</p> <p>The brake system continues to function normally, but without the functions listed above. The front and rear wheels could therefore lock, for example, if you brake hard.</p> <p>The steerability and braking characteristics may be severely affected. The braking distance may increase in an emergency braking situation.</p> <p>If ESP[®] is not operational, ESP[®] is unable to stabilise the vehicle. There is an increased danger of skidding and risk of an accident.</p> <ul style="list-style-type: none"> ► Observe the additional display messages in the multifunction display. ► Drive on carefully. ► Visit a qualified specialist workshop.
    <p>The red brake warning lamp, the yellow ESP[®] and ESP[®] OFF warning lamps and the yellow ABS warning lamp are lit while the engine is running.</p>	<p>ABS and ESP[®] are unavailable due to a fault. Therefore, BAS, BAS PLUS, COLLISION PREVENTION ASSIST, EBD, PRE-SAFE[®], PRE-SAFE[®] Brake, the HOLD function, hill start assist, ESP[®] trailer stabilisation and the adaptive brake lights, for example, are not available either.</p> <p>ATTENTION ASSIST is deactivated.</p> <p> WARNING</p> <p>The brake system continues to function normally, but without the functions listed above. The front and rear wheels could therefore lock, for example, if you brake hard.</p> <p>The steerability and braking characteristics may be severely affected. The braking distance may increase in an emergency braking situation.</p> <p>If ESP[®] is not operational, ESP[®] is unable to stabilise the vehicle. There is an increased danger of skidding and risk of an accident.</p> <ul style="list-style-type: none"> ► Observe the additional display messages in the multifunction display. ► Drive on carefully. ► Visit a qualified specialist workshop.

Problem	Possible causes/consequences and ► Solutions
 <p>The yellow ESP® warning lamp flashes while the vehicle is in motion.</p>	<p>ESP® or traction control has intervened because there is a risk of skidding or at least one wheel has started to spin. Cruise control or DISTRONIC PLUS is deactivated.</p> <ul style="list-style-type: none"> ► Only depress the accelerator pedal as far as necessary when pulling away. ► Accelerate more gently while the vehicle is in motion. ► Adapt your driving style to suit the road and weather conditions. ► Do not deactivate ESP®. <p>For exceptions; see: (► page 77).</p>
 <p>The yellow ESP® OFF warning lamp is lit while the engine is running.</p>	<p>ESP® is deactivated.</p> <p> WARNING</p> <p>If ESP® is deactivated, ESP® is unable to stabilise the vehicle. There is an increased danger of skidding and risk of an accident.</p> <ul style="list-style-type: none"> ► Reactivate ESP®. <p>For exceptions; see: (► page 77).</p> <ul style="list-style-type: none"> ► Adapt your driving style to suit the road and weather conditions. <p>If ESP® cannot be activated:</p> <ul style="list-style-type: none"> ► Drive on carefully. ► Have ESP® checked at a qualified specialist workshop.
 <p>AMG vehicles only: The yellow SPORT handling mode warning lamp is lit while the engine is running.</p>	<p>SPORT handling mode is activated.</p> <p> WARNING</p> <p>When SPORT handling mode is switched on, ESP® is unable to stabilise the vehicle. There is an increased danger of skidding and risk of an accident.</p> <ul style="list-style-type: none"> ► Only switch to SPORT handling mode in accordance with the conditions written in the "Activating/deactivating SPORT handling mode" section (► page 79).



Problem	Possible causes/consequences and ► Solutions
 <p>The yellow ESP[®] and ESP[®] OFF warning lamps are lit while the engine is running.</p>	<p>ESP[®], BAS, BAS PLUS, COLLISION PREVENTION ASSIST, PRE-SAFE[®], PRE-SAFE[®] Brake, the HOLD function, hill start assist, ESP[®] trailer stabilisation and the adaptive brake lights are not available due to a malfunction. ATTENTION ASSIST is deactivated.</p> <p> WARNING</p> <p>The brake system continues to function normally, but without the functions listed above. The braking distance may thus increase in an emergency braking situation. If ESP[®] is not operational, ESP[®] is unable to stabilise the vehicle. There is an increased danger of skidding and risk of an accident.</p> <ul style="list-style-type: none"> ► Observe the additional display messages in the multifunction display. ► Drive on carefully. ► Visit a qualified specialist workshop.
 <p>The red SRS warning lamp is lit while the engine is running.</p>	<p>There is a malfunction in the SRS (Supplemental Restraint System).</p> <p> WARNING</p> <p>The airbags or belt tensioners may either be triggered unintentionally or, in the event of an accident, may not be triggered. This poses an increased risk of injury.</p> <ul style="list-style-type: none"> ► Drive on carefully. ► Have SRS checked at a qualified specialist workshop immediately. <p>For further information about the Supplemental Restraint System; see (> page 43).</p>





Engine	
Problem	Possible causes/consequences and ► Solutions
 <p>The yellow engine diagnostics warning lamp lights up while the engine is running.</p>	<p>There may be a fault, for example:</p> <ul style="list-style-type: none"> • in the engine management • in the fuel injection system • in the exhaust system • in the ignition system (for vehicles with petrol engines) • in the fuel system <p>The emission limit values may be exceeded and the engine may be running in emergency mode.</p> <p>► Have the vehicle checked as soon as possible at a qualified specialist workshop.</p> <p>Vehicles with a diesel engine: the fuel tank has been run dry (▷ page 198).</p> <p>► Start the engine three to four times after refuelling. If the yellow engine diagnostics warning lamp goes out, emergency running mode is cancelled. The vehicle need not be checked.</p>
 <p>The yellow reserve fuel warning lamp lights up while the engine is running.</p>	<p>The fuel level has dropped into the reserve range.</p> <p>Operation of the auxiliary heating is deactivated if the fuel level drops into the reserve range.</p> <p>► Refuel at the nearest filling station.</p>
 <p>The red coolant warning lamp lights up while the engine is running and the coolant temperature gauge is at the start of the scale.</p>	<p>The temperature sensor for the coolant temperature gauge is faulty.</p> <p>The coolant temperature is no longer being monitored. There is a risk of engine damage if the coolant temperature is too high.</p> <p>► Stop the vehicle immediately, paying attention to road and traffic conditions, and switch off the engine. Do not continue driving under any circumstances.</p> <p>► Secure the vehicle against rolling away (▷ page 199).</p> <p>► Consult a qualified specialist workshop.</p>

Problem	Possible causes/consequences and ► Solutions
 <p>The red coolant warning lamp comes on while the engine is running.</p>	<p>The coolant level is too low.</p> <p>If the coolant level is correct, the airflow to the engine radiator may be blocked or the electric engine radiator fan may be malfunctioning.</p> <p>The coolant is too hot and the engine is no longer being cooled sufficiently.</p> <ul style="list-style-type: none"> ► Observe the additional display messages in the multifunction display. ► Stop the vehicle immediately, paying attention to road and traffic conditions, and switch off the engine. ► Secure the vehicle against rolling away (▷ page 199). ► Leave the vehicle and keep a safe distance from the vehicle until the engine has cooled down. ► Check the coolant level and top up the coolant, observing the warning notes (▷ page 368). ► If you have to top up the coolant frequently, have the engine cooling system checked. ► Make sure that the air supply to the engine radiator is not blocked, e.g. by frozen slush. ► Do not start the engine again until the coolant temperature is under 120 °C. The engine may otherwise be damaged. ► Drive to the nearest qualified specialist workshop. ► Avoid heavy loads on the engine as you do so, e.g. driving in mountainous terrain and stop-start traffic.
 <p>The red coolant warning lamp comes on while the engine is running. A warning tone also sounds.</p>	<p>The coolant temperature has exceeded 120 °C. The airflow to the engine radiator may be blocked or the coolant level may be too low.</p> <p> WARNING</p> <p>The engine is not being cooled sufficiently and may be damaged. Never drive with an overheated engine. Driving when your engine is overheated can cause some fluids which may have leaked into the engine compartment to catch fire.</p> <p>Steam from an overheated engine can cause serious burns, which can occur just by opening the bonnet.</p> <p>This poses a risk of injury.</p> <ul style="list-style-type: none"> ► Observe the additional display messages in the multifunction display. ► Stop the vehicle immediately, paying attention to road and traffic conditions, and switch off the engine. ► Secure the vehicle against rolling away (▷ page 199).

Problem	Possible causes/consequences and ► Solutions
	<ul style="list-style-type: none"> ► Leave the vehicle and keep a safe distance from the vehicle until the engine has cooled down. ► Check the coolant level and top up the coolant, observing the warning notes (▷ page 368). ► If you have to top up the coolant frequently, have the engine cooling system checked. ► Make sure that the air supply to the engine radiator is not blocked, e.g. by frozen slush. ► If the coolant temperature is below 120 °C, you can continue driving to the nearest qualified specialist workshop. ► Avoid heavy loads on the engine as you do so, e.g. driving in mountainous terrain and stop-start traffic.

Driving systems

Problem	Possible causes/consequences and ► Solutions
 <p>The red distance warning lamp lights up while the vehicle is in motion.</p>	<p>The distance to the vehicle in front is too small for the speed selected.</p> <ul style="list-style-type: none"> ► Increase the distance.
 <p>The red distance warning lamp lights up while the vehicle is in motion. A warning tone also sounds.</p>	<p>You are approaching a vehicle or a stationary obstacle in your line of travel at too high a speed.</p> <ul style="list-style-type: none"> ► Be prepared to brake immediately. ► Pay careful attention to the traffic situation. You may have to brake or take evasive action. <p>Further information on PRE-SAFE® Brake (▷ page 81). For further information on the distance warning function of COLLISION PREVENTION ASSIST: (▷ page 75).</p>

Tyres	
Problem	Possible causes/consequences and ► Solutions
 <p>The yellow tyre pressure monitor warning lamp (pressure loss/malfunction) is lit.</p>	<p>The tyre pressure monitor has detected a loss of pressure in at least one of the tyres.</p> <p> WARNING</p> <p>With tyre pressures which are too low, there is a risk of the following hazards:</p> <ul style="list-style-type: none"> • the tyres may burst, especially as the load and vehicle speed increase. • the tyres may wear excessively and/or unevenly, which may greatly impair tyre traction. • the driving characteristics, as well as steering and braking, may be greatly impaired. <p>There is a risk of an accident.</p> <ul style="list-style-type: none"> ► Stop the vehicle without making any sudden steering or braking manoeuvres. Pay attention to the traffic conditions as you do so. ► Secure the vehicle against rolling away (▷ page 199). ► Observe the additional display messages in the multifunction display. ► Check the tyres and, if necessary, follow the instructions for a flat tyre (▷ page 385). ► Check the tyre pressure (▷ page 410). ► If necessary, correct the tyre pressure.
 <p>The yellow tyre pressure monitor warning lamp (pressure loss/malfunction) flashes for approximately one minute and then remains lit.</p>	<p>The tyre pressure monitor is faulty.</p> <p> WARNING</p> <p>The system is possibly unable to recognise or register low tyre pressure.</p> <p>There is a risk of an accident.</p> <ul style="list-style-type: none"> ► Observe the additional display messages in the multifunction display. ► Visit a qualified specialist workshop.

Useful information	330
Stowage areas	330
Features	348

Useful information

- i** This Owner's Manual describes all models, series and optional equipment for your vehicle that were available at the time of going to press. National variations are possible. Note that your vehicle may not be equipped with all of the functions described. This is also the case for systems and functions relevant to safety.
- i** Read the information on qualified specialist workshops: (▷ page 26).

Stowage areas

Loading guidelines

WARNING

If objects, luggage or loads are not secured or not secured sufficiently, they could slip, tip over or be flung around and thereby hit vehicle occupants. There is a risk of injury, especially when braking or abruptly changing directions. Always store objects so that they cannot be flung around. Secure objects, luggage or loads against slipping or tipping before the journey.

WARNING

Combustion engines emit poisonous exhaust gases such as carbon monoxide. Exhaust gases can enter the vehicle interior if the boot lid/tailgate is open when the engine is running, especially if the vehicle is in motion. There is a risk of poisoning.

Always switch off the engine before opening the boot lid/tailgate. Never drive with the boot lid/tailgate open.

The handling characteristics of a laden vehicle are dependent on the distribution of the load within the vehicle. For this reason, you should observe the following notes when transporting a load:

- when transporting a load, never exceed the maximum permissible gross vehicle weight

or the permissible axle loads for the vehicle (including occupants).

- the boot/luggage compartment is the preferred place to store objects.
 - position heavy loads as far forwards as possible and as low down in the boot/luggage compartment as possible.
 - the load must not protrude above the upper edge of the seat backrests.
 - always place the load against the rear or front seat backrests. Make sure that the seat backrests are securely locked into place.
 - always place the load behind unoccupied seats if possible.
 - use the lashing eyelets and the luggage nets to transport loads and luggage.
 - only use lashing eyelets and fastening components that are suitable for the weight and size of the load.
 - when transporting objects in the luggage compartment, the combined luggage cover and net must always be installed (luggage compartment cover and safety net).
 - secure the load with sufficiently strong and wear-resistant lashing material. Pad sharp edges for protection.
- i** Load restraints are available at any qualified specialist workshop, e.g. a Mercedes-Benz Service Centre.

Stowage spaces

Important safety notes

WARNING

If objects in the passenger compartment are stowed incorrectly, they can slide or be thrown around and hit vehicle occupants. There is a risk of injury, particularly in the event of sudden braking or a sudden change in direction.

- Always stow objects so that they cannot be thrown around in such situations.
- Always make sure that objects do not protrude from stowage spaces, luggage nets or stowage nets.
- Close the lockable stowage spaces while driving.
- Always stow and secure heavy, hard, pointed, sharp-edged, fragile or bulky objects in the boot/luggage compartment.

Observe the loading guidelines (▷ page 330).

Glove compartment



- ▶ **To open:** pull handle ① and open glove compartment flap ②.
- ▶ **To close:** fold glove compartment flap ② upwards until it engages.

i The glove compartment can be ventilated (▷ page 173).

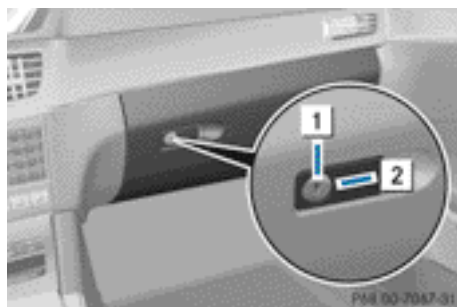

The glove compartment can only be locked and unlocked using the emergency key element.

- ▶ **To lock:** insert the emergency key element into the lock and turn it 90° clockwise to position ②.
- ▶ **To unlock:** insert the emergency key element into the lock and turn it 90° anti-clockwise to position ①.

Spectacles compartment

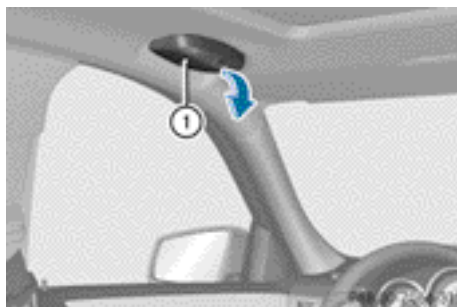

There is a compartment to stow spectacles in the roof lining on the driver's side.

- ▶ **To open:** pull down spectacles compartment ① by the handle.

Storage compartments in the centre console

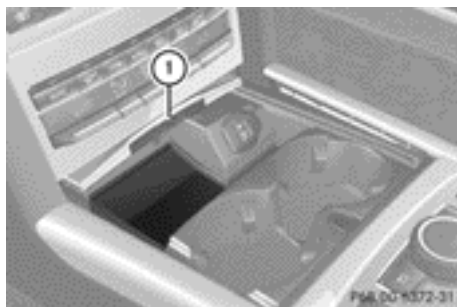

Front storage compartment (vehicles with DIRECT SELECT lever)

- ▶ **To open:** slide cover ① forwards until it engages.
- ▶ **To close:** briefly press cover ① at the front. Cover ① moves back.



Rear storage compartment (vehicles with DIRECT SELECT lever)

- ▶ **To open:** slide cover ① forwards until it engages.
- ▶ **To close:** briefly press cover ① at the front. Cover ① moves back.

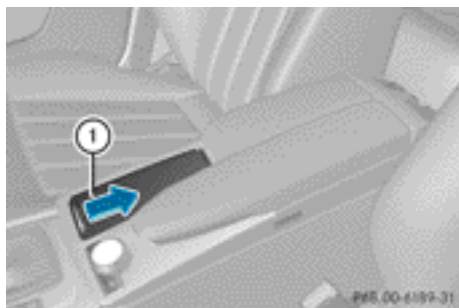

Vehicles with manual transmission and AMG vehicles

- ▶ **To open:** slide cover ① back.

Stowage compartment/telephone compartment under the armrest

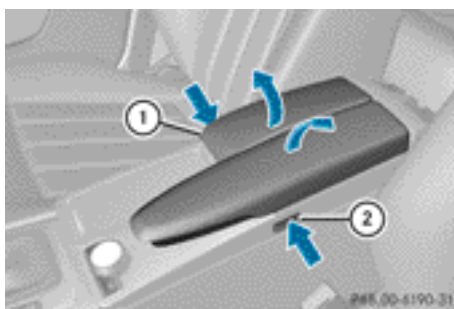

Vehicles with manual transmission and AMG vehicles

- ▶ **To open:** press left-hand button ② or right-hand button ①. The stowage compartment opens.

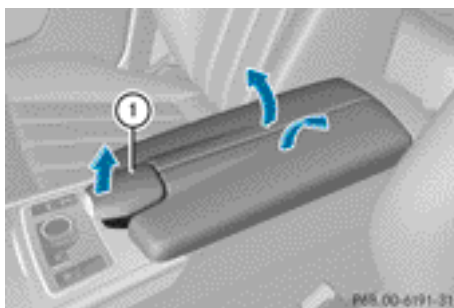

Vehicles with DIRECT SELECT lever

- ▶ **To open:** pull handle ① up. The armrest folds out.
- i** Depending on the vehicle's equipment, a USB port and an AUX-IN jack or a Media Interface are installed in the stowage compartment.
- Before using these connections, you must remove the mobile phone bracket (see the separate installation instructions) and fold up the pre-installed mobile phone holder (see the separate Audio 20/COMAND Online operating instructions).

Stowage compartment under the front seats

⚠ WARNING

If you exceed the maximum permitted load of the stowage compartment, the cover is unable to restrain the objects. Objects may be thrown out of the stowage compartment and hit vehicle occupants as a result. There is a risk of injury, particularly in the event of sudden braking or a sudden change in direction.

Always observe the maximum load of the stowage compartment. Stow and secure heavy objects in the boot/luggage compartment.

The maximum permissible load of the stowage compartment is 1.5 kg.

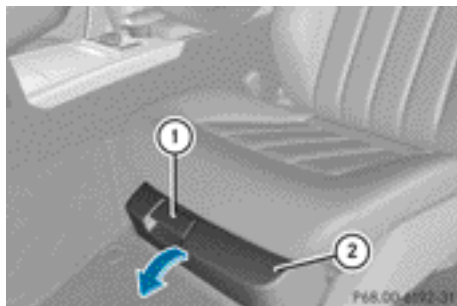

► **To open:** pull handle ① up and fold cover ② forwards.

i On vehicles with a fire extinguisher, the fire extinguisher is located in the stowage compartment under the driver's seat.

Stowage compartment in the rear compartment

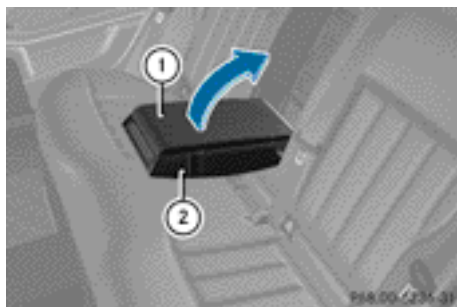

Vehicles with a rear bench seat

- **To open:** fold down seat armrest ②.
- Fold cover ① of the armrest upwards.

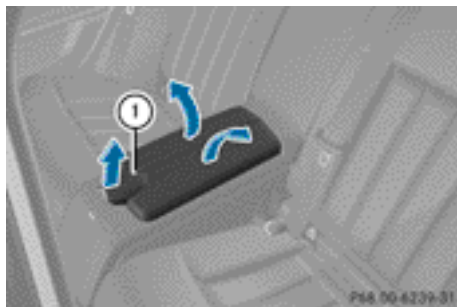

Vehicles with luxury single seats in the rear compartment

- Pull handle ① upwards. The armrest folds out.

Stowage net in the rear compartment



Vehicles with a rear bench seat

- ① Stowage net

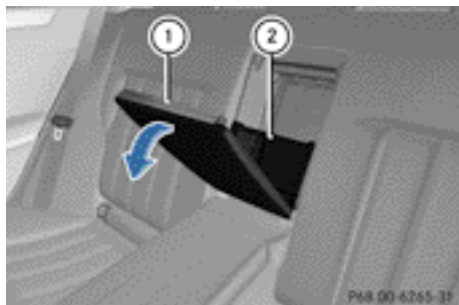

Vehicles with luxury single seats in the rear compartment

- ① Handle strip
- ② Stowage net

- ▶ Pull handle strip ① on the upper edge of the cover forwards until it is released from its anchorage.
- ▶ Fold down the cover in the direction of the arrow.

Stowage nets

Stowage nets are located in the front-passenger footwell and on the left and right-hand sides of the boot/luggage compartment.

Observe the loading guidelines (▷ page 330) and the safety notes regarding stowage spaces (▷ page 330).

Skibag

Unfolding the skibag and loading skis

WARNING

The skibag in conjunction with the lashing straps cannot restrain any objects other than skis.

Vehicle occupants could be struck in the event of sudden braking or an accident, for instance, if you:

- transport other heavy or sharp-edged objects in the skibag
- do not secure the skibag with the lashing straps

There is a risk of accident and injury.

Store only skis in the skibag. Always secure the skibag with the lashing straps so that it cannot move around.

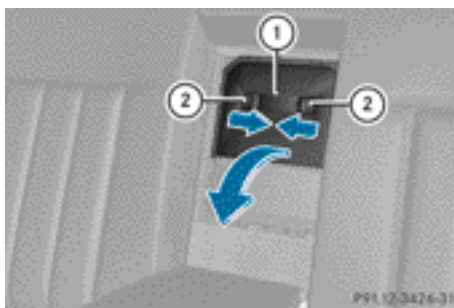

- ▶ Fold down the rear seat armrest.
- ▶ Press release catches ② together and fold down cover ①.

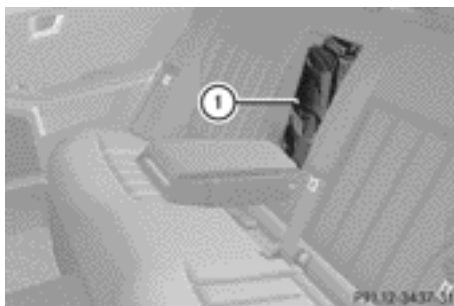

- ▶ Pull skibag ① into the vehicle interior and unfold it.
- ▶ Open the boot lid.

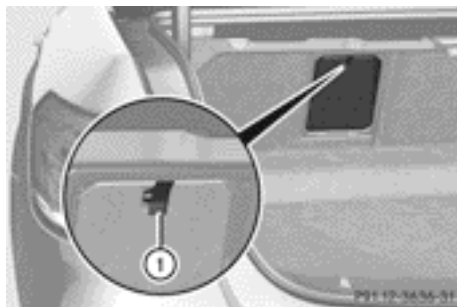

- ▶ Press release catch ①.
The flap opens downwards.
- ▶ Slide the skis into the skibag from the boot.

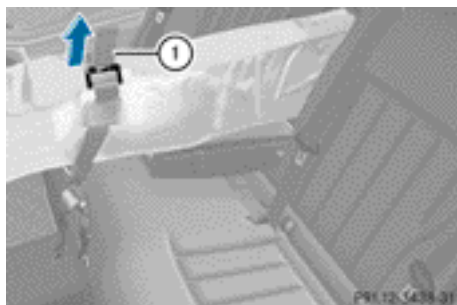

- ▶ Pull strap ① tight by the loose end until the skis are held firmly inside the skibag.

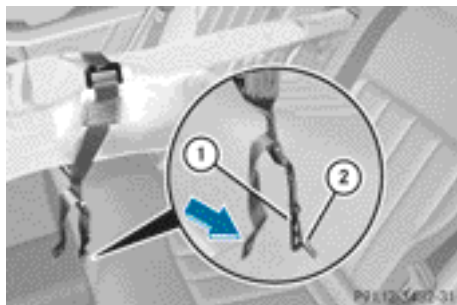

- ▶ Engage hook ① in securing ring ②.
- ▶ Pull the strap tight by the loose end.

Removing the skis and folding up the skibag

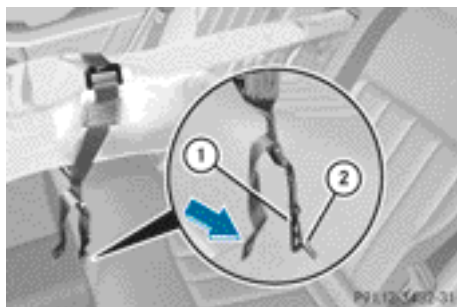

- ▶ Loosen the two straps.
- ▶ Remove hook ① from securing ring ②.
- ▶ Take the skis out of the skibag.
- ▶ Close the flap in the boot.
- ▶ Smooth out the skibag and fold it up.
- ▶ Put the skibag into the backrest.
- ▶ Fold the cover back up.

i You should always close the flap in the boot if you do not require the skibag. This will prevent unauthorised access to the boot from the vehicle interior.

Removing the skibag



If you would like to clean or dry the skibag, it can be removed.

- ▶ Open the boot lid.
- ▶ Press release catch ①.
Flap ② folds down.
- ▶ Press catch ③ in and pull out frame ④ containing the skibag.

Through-loading facility in the rear compartment

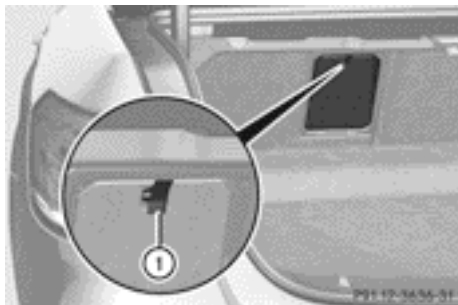

The through-loading facility is opened from the boot.

- ▶ Fold down the rear seat armrest.
 - ▶ Press release catch ①.
- The flap opens downwards.

Observe the loading guidelines (▷ page 330).

Through-loading facility in the rear bench seat (Saloon)

Important safety notes

WARNING

If the rear bench seat/rear seat and seat backrest are not engaged they could fold forwards, e.g. when braking suddenly or in the event of an accident.

- The vehicle occupant would thereby be pushed into the seat belt by the rear bench seat/rear seat or by the seat backrest. The seat belt cannot protect as intended and could result in additional injury.
- Objects or loads in the boot cannot be restrained by the seat backrest.

This poses an increased risk of injury.

Before every trip, make sure that the seat backrests and the rear bench seat/rear seat are engaged before every trip.

Observe the loading guidelines (▷ page 330).

The left-hand and right-hand rear seat backrests can be folded down separately to increase the boot capacity.

Folding the seat backrest forwards

- ❗ Before you fold down the rear seat backrest, remove the side head restraints for the integrated child seat; see the "Side head restraints for integrated child seat" section. The side head restraints could otherwise be damaged.



- ❗ Vehicles with memory function: when you fold one or both parts of the rear seat backrest forwards, the respective front seat moves forward slightly, when necessary, in order to avoid contact.

- ▶ Vehicles without memory function: if necessary, move the driver's or front-passenger seat forwards.
 - ▶ Open the boot.
 - ▶ Pull right-hand or left-hand rear seat backrest release handle ①.
- The corresponding rear seat backrest is released.
- The seat backrest head restraints in the rear compartment lower.

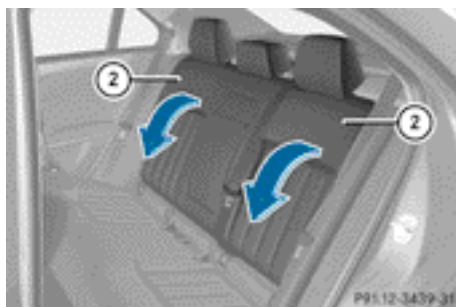

- ▶ Fold rear seat backrest ② forwards.
- ▶ Move the driver's or front-passenger seat back if necessary.

Folding back the seat backrest

! Make sure that the seat belt does not become trapped when folding the rear seat backrest back. Otherwise, it could be damaged.

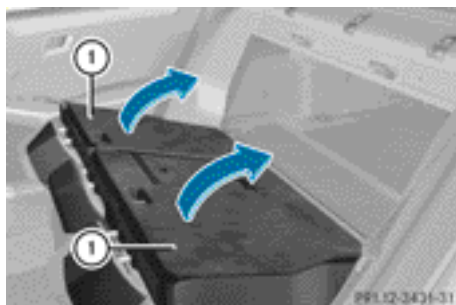

- ▶ Move the driver's or front-passenger seat forward if necessary.
- ▶ Fold rear seat backrest ① back until it engages.
If the rear seat backrest is not engaged and locked, this will be shown in the multifunction display in the instrument cluster. A warning tone also sounds.
- ▶ Adjust the head restraints if necessary (▷ page 118).
- ▶ Move the driver's or front-passenger seat back if necessary.

i If you do not need the through-loading feature, you should always engage the rear

seat backrests. This will prevent unauthorised access to the boot from the vehicle interior.

EASY-PACK through-loading facility in the rear bench seat (Estate)

Important safety notes

⚠ WARNING

If the rear bench seat/rear seat and seat backrest are not engaged they could fold forwards, e.g. when braking suddenly or in the event of an accident.

- The vehicle occupant would thereby be pushed into the seat belt by the rear bench seat/rear seat or by the seat backrest. The seat belt cannot protect as intended and could result in additional injury.
- Objects or loads in the boot/luggage compartment cannot be restrained by the seat backrest.

This poses an increased risk of injury.

Before every trip, make sure that the seat backrests and the rear bench seat/rear seat are engaged before every trip.

Observe the loading guidelines (▷ page 330).

Folding the rear seat backrest forward

! Before you fold down the rear seat backrest, remove the side head restraints for the integrated child seat; see the "Side head restraints for integrated child seat" section. The side head restraints could otherwise be damaged.

! When folding the rear seat backrest forwards, ensure that there are no items lying on the seat cushions. These items could otherwise be damaged or could themselves damage the rear seats.

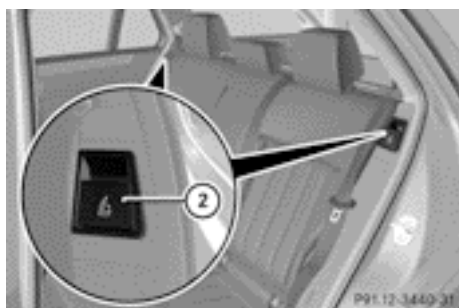
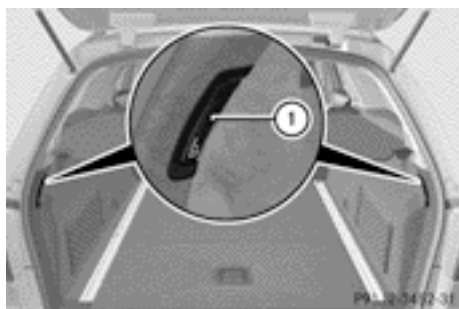

The left-hand and right-hand rear seat backrests can be folded forwards separately to increase the luggage compartment capacity. The combined luggage cover and net can remain installed.

- i** When you fold one or both parts of the rear seat backrests forwards, the headrests are also lowered if necessary. In the case of vehicles with memory function, the respective front seat is moved forwards slightly to avoid contact with the seat behind it.
- ▶ Vehicles without memory function: if necessary, move the driver's or front-passenger seat forwards.
- ▶ Pull the left-hand or right-hand release handle at the rear in load compartment ① or at the side beside backrests ②. The corresponding backrest folds forwards.

- ▶ Pull back the left or right release lever in the luggage compartment ①. The corresponding backrest folds forwards.
- ▶ Move the driver's or front-passenger seat back if necessary.

Folding the rear seat backrest back

- i** Make sure that the seat belt does not become trapped when folding the rear seat backrest back. Otherwise, it could be damaged.

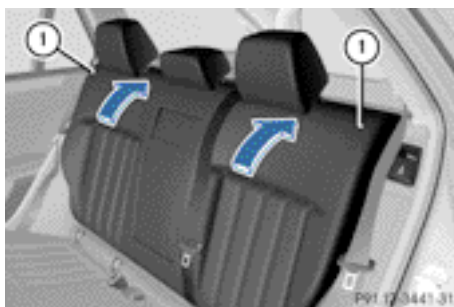

- ▶ Move the driver's or front-passenger seat forward if necessary.
- ▶ Fold seat backrest ① back until it engages. If the rear seat backrest is not engaged and locked, this will be shown in the multifunction display in the instrument cluster. A warning tone also sounds.
- ▶ Adjust the head restraints if necessary (▷ page 118).
- ▶ Move the driver's or front-passenger seat back if necessary.

Securing a load

Plastic hooks (Saloon)



On vehicles without a through-loading feature in the rear bench seat, six plastic hooks are fitted to the boot floor. You can use these to attach the luggage securing fixture, which is available as an accessory.

Lashing eyelets

General notes

Observe the following notes on securing loads:

- Observe the loading guidelines (▷ page 330).
- Secure the load using the lashing eyelets.
- Distribute the load on the lashing eyelets evenly.
- Do not use elastic straps or nets to secure a load, as these are only intended as an anti-slip protection for light loads.
- Do not route lashing materials across sharp edges or corners.
- Pad sharp edges for protection.

Boot/luggage compartment



Lashing eyelets ① (Sedan)

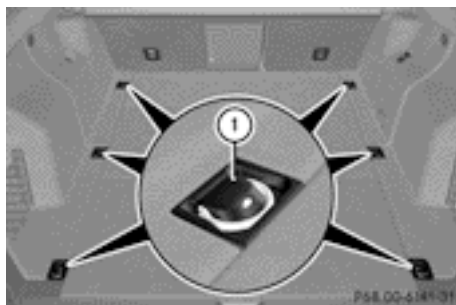

Lashing eyelets ① (Estate)

Bag hook

⚠ WARNING

The bag hooks cannot restrain heavy objects or items of luggage. Objects or items of luggage could be flung around and thereby hit vehicle occupants when braking or abruptly changing directions. There is a risk of injury.

Only hang light objects on the bag hooks. Never hang hard, sharp-edged or fragile objects on the bag hooks.

- ❗ The bag hook can bear a maximum load of 3 kg. Do not use it to secure a load.



Estate

- ▶ **To open:** press bag hook ① (arrow). Bag hook ① slides out.
- ▶ **To close:** press bag hook ① until it engages.

EASY-PACK luggage compartment cover

Important safety notes

WARNING

On its own, the luggage compartment cover cannot secure or restrain heavy objects, items of luggage and heavy loads. You could be hit by an unsecured load during sudden changes in direction, braking or in the event of an accident. There is an increased risk of injury or even fatal injury.

Always store objects so that they cannot be flung around. Secure objects, luggage or loads against slipping or tipping over, e.g. by using lashing material, even if you are using the luggage compartment cover.

- ❗ When loading the vehicle, make sure that you do not stack the load in the luggage compartment higher than the lower edge of the side windows. Do not place heavy objects on top of the luggage compartment cover.

The luggage compartment cover and the safety net are attached to anchorages on the right and left in the luggage compartment as a combined luggage cover and net.

When the tailgate is opened, the luggage compartment cover is automatically raised to make loading easier. It is automatically lowered again when the tailgate is closed.

When the luggage compartment cover is clipped in, there should be no objects obstructing the downwards movement of the cover in the luggage compartment when the tailgate is closed. The luggage compartment cover will otherwise be raised again.

Extending and retracting the luggage compartment cover

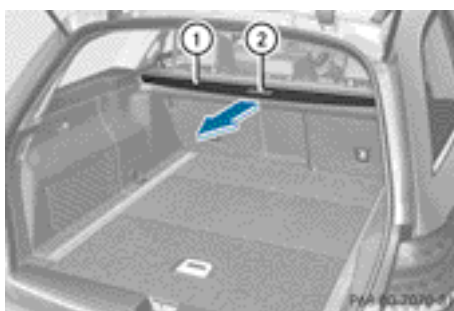

- ▶ **To extend:** pull luggage compartment cover ① back by grab handle ② and clip it into retainers on the left and right.

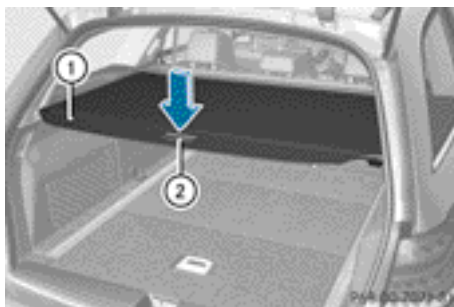

- ▶ **To retract:** unhook luggage compartment cover ① from the retainers on the left and right and guide it forwards by grab handle ② until it is fully retracted.

Fitting and removing the combined luggage cover and net

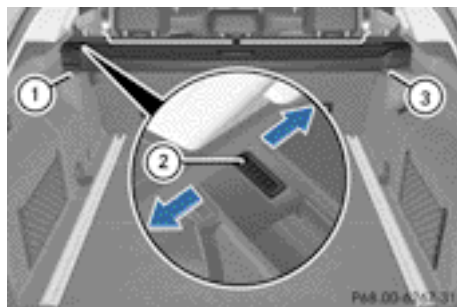

You can reach the combined luggage cover and net to install and remove it from the luggage compartment and, with the seat backrest folded forwards, from the left-hand rear door.

- ▶ Make sure that the safety net and the luggage compartment cover are rolled up.
- ▶ **To remove:** press button ②.
- ▶ Fold the combined luggage cover and net forwards on the left-hand side with the seat backrest folded forwards, and fold it backwards with the seat backrest folded up.
- ▶ First, detach the combined luggage cover and net from left-hand catch ① and then remove it from right-hand fixture ③.
- ▶ **To install:** push the combined luggage cover and net up to the stop into right-hand fixture ③.
- ▶ Place the combined luggage cover and net into the left-hand fixture and push it into catch ① until the combined luggage cover and net engages audibly.

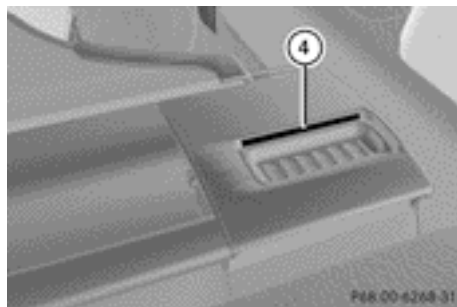

- ▶ Make sure that red lock status indicator ④ is no longer visible. The combined luggage cover and net will otherwise not be locked in place.

Attaching the combined luggage cover and net to the rear seat backrest

- ❗ If you have attached the combined luggage cover and net to a rear seat backrest that is folded forwards, do not fold the backrest back.

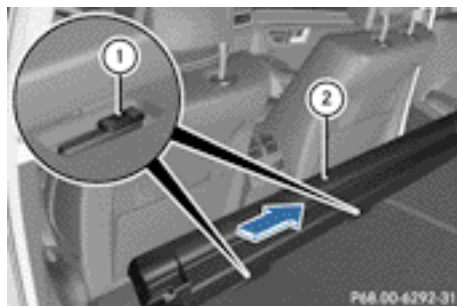

- ▶ Fold the left and right seat backrest forwards (▷ page 337).
- ▶ Insert combined luggage cover and net ② into two guides ① and push it up to the stop in the direction of the arrow.

Safety net (Estate)

Important safety notes

WARNING

On its own, the safety net cannot secure or restrain heavy objects, items of luggage and heavy loads. You could be hit by an unsecured load during sudden changes in direction, braking or in the event of an accident. There is an increased risk of injury or even fatal injury.

Always store objects so that they cannot be flung around. Secure objects, luggage or loads against slipping or tipping over, e.g. by using lashing material, even if you are using the safety net.

It is important to use a safety net if you load the vehicle with small objects above the seat backrests. For safety reasons, always use a safety net when transporting a load.

Safety net without luggage compartment enlargement

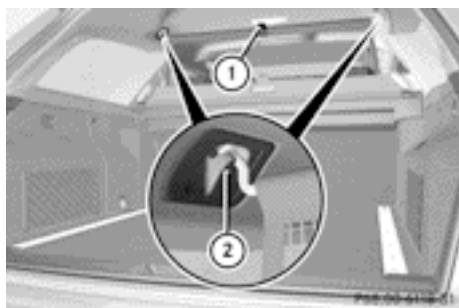

- ▶ Pull the safety net up by tab ① and hook it into eyelets ②.

Safety net with luggage compartment enlargement

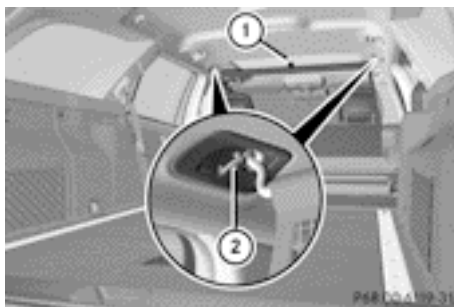

- ▶ Make sure that the safety net is attached to the rear seat backrest (▷ page 341).
- ▶ Guide the safety net up by tab ① and hook it into eyelets ②.

Coat hooks on the tailgate

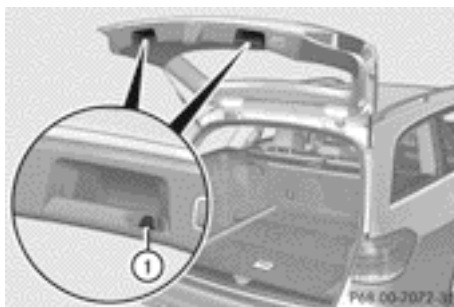

- ① Coat hook

EASY-PACK boot box

Important safety notes

WARNING

When the load surface moves up, your hands may become trapped on the frame of the EASY-PACK boot box. There is a risk of injury. When the load surface moves up, make sure that your hands are not within the sweep of the load surface. If someone becomes trapped, carefully push the centre of the load surface downward.

! When the EASY-PACK convenience box is pulled out, no objects may be placed on the frame of the box or pushed onto the frame from above. Otherwise, the box could be damaged.

! Sharp-edged, pointed or fragile objects can damage the EASY-PACK boot box and then be thrown out. There is a risk of injury. Do not transport sharp-edged, pointed or fragile objects in the EASY-PACK boot box. Always store and secure these or similar objects in the boot outside of the EASY-PACK boot box.

! If you exceed the maximum permitted load of the EASY-PACK boot box, objects can be thrown out of the EASY-PACK boot box and strike vehicle occupants. There is a risk of injury, particularly in the event of sudden braking or a sudden change in direction.

Always observe the maximum permitted load of the EASY-PACK boot box. Always store and secure heavy objects in the boot outside of the EASY-PACK boot box.

The maximum permitted load of the EASY-PACK boot box is 10 kg. With a load of above approx. 5 kg, the bottom of the box moves downward until it rests on the mat of the boot floor. Thus, overloading of the box is avoided.

Adjusting the height to any position

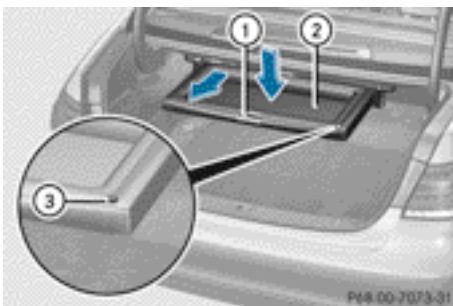

- ▶ Pull the box out by handle ① in the direction of the arrow all the way to the stop.
- ▶ **Lowering the load surface:** push the centre of load surface ② down by hand in the direction of the arrow until load surface ② has reached the desired position and the box is the desired size.
- ▶ **To raise the load surface:** press switch ③. Load surface ② of the box moves up automatically.
- ▶ **To stow the box:** push the box in by handle ① all the way to the stop.

Removing and fitting

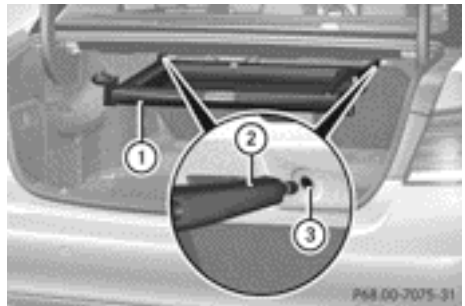

- ▶ **To install:** insert retainer ② of box ① into slots ③

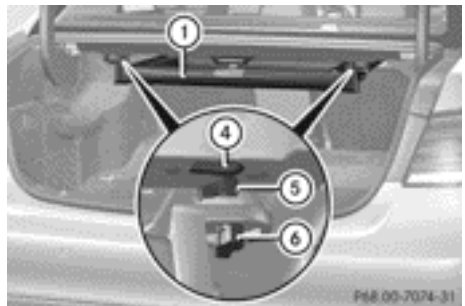

- ▶ Raise box ① and press hooks ⑤ into anchorage ④ as far as they will go.
- ▶ Turn left-hand rotating catch ⑥ clockwise and right-hand rotating catch ⑥ anti-clockwise by 90°.

► **To remove:** turn left-hand rotating catch ⑥ anti-clockwise and right-hand rotating catch ⑥ clockwise by 90°.

► Move box ① downwards and pull it out from anchorages ④.

i Store the EASY-PACK boot box on a flat surface after removal, e.g. on a suitable shelf.

EASY-PACK load-securing kit (Estate)

Components and storage

The EASY-PACK load-securing kit allows you to use your luggage compartment for a variety of purposes. The accessory parts are located under the luggage compartment floor.

► Open the EASY-PACK folding luggage-compartment floor (► page 346).

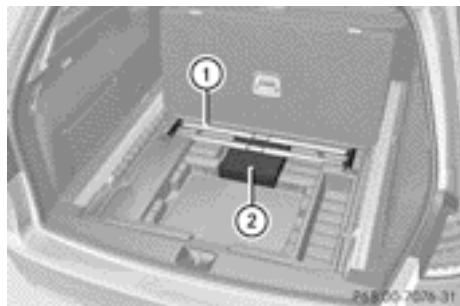

EASY-PACK load-securing kit accessory parts

- ① Telescopic rod
- ② Bag containing the brackets and luggage holder

Inserting the brackets into the loading rail

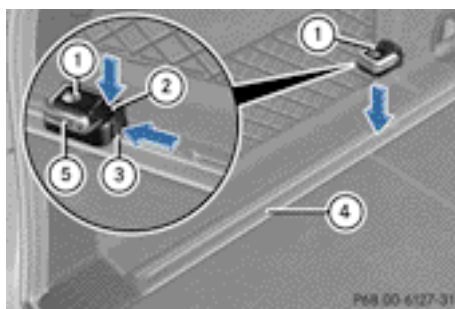

- Insert bracket ① into the centre of loading rail ④.
- Press release button ② and push bracket ① into the desired position in loading rail ④.
- Let go of release button ②.
- Press locking button ③.
- Bracket ① is locked in loading rail ④.
- If necessary, fold lashing eyelet ⑤ upwards.

Luggage holder

! Only use the luggage holder to secure loads with a maximum weight of 7 kg and with dimensions that allow the loads to be safely and securely retained by the luggage holder.

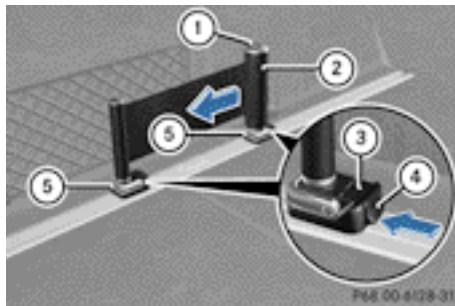

The luggage holder can be used to secure light loads against the side wall of the luggage compartment to prevent them from moving around.

- ▶ **To install:** insert two brackets ⑤ into the left or right loading rail (▷ page 344).
 - ▶ Press release button ① of the luggage holder and pull the strap out slightly.
 - ▶ Insert luggage holder ② into brackets ⑤ and, while doing so, press release button ③ and push the luggage holder downwards until it engages.
 - ▶ Press release button ① of the luggage holder and pull the strap out in the direction of the arrow.
 - ▶ Place the load between the strap and the luggage compartment side wall.
 - ▶ Using one hand, press locking button ① of the luggage holder.
 - ▶ With your other hand, let the strap go slowly until the load is secured.
 - ▶ Make sure that locking button ④ on brackets ⑤ is pressed. This keeps brackets ⑤ in place on the loading rail.
 - ▶ **To remove:** press release button ③ on respective bracket ⑤ and remove luggage holder ② by pulling upwards and out.
- ▶ **To install:** insert one bracket ② into both the left and the right loading rails and slide it to the desired position (▷ page 344).
 - ▶ Insert telescopic rod ① into brackets ② and, while doing so, press release button ④ and push the rod downwards until it engages.
 - ▶ Make sure that locking button ③ on brackets ② is pressed. This keeps brackets ② in place on the loading rail.
 - ▶ **To remove:** press release button ④ on respective bracket ② and remove telescopic rod ① by pulling it upwards and out.

Stowage well under the boot floor (Saloon)

- ! Remove the handle again before closing the boot lid and snap it in tightly to prevent the handle flap from protruding. Otherwise, you could damage the handle.

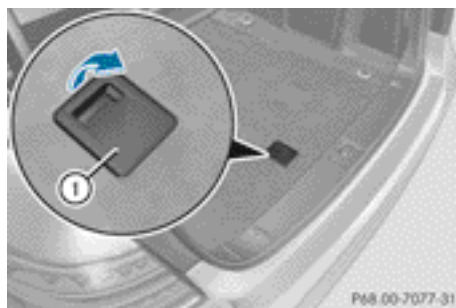

The TIREFIT kit, the vehicle tool kit, etc are located in the stowage compartment.

- ▶ **To open:** pull handle ① up.

Telescopic rod

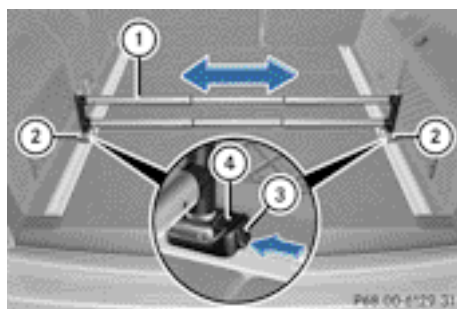

The telescopic rod can be used to secure the load against the rear seats to prevent it from moving around.



- ▶ Hook handle ① into rain trough ②.

EASY-PACK folding floor with storage compartment under the luggage compartment floor (Estate)

Important safety notes

WARNING

If you drive when the EASY-PACK folding floor is open, objects could be flung around, thus striking vehicle occupants. There is a risk of injury, particularly in the event of sudden braking or a sudden change in direction.

Always close the EASY-PACK folding floor before a journey.

- ❗ Do not apply pressure to the EASY-PACK folding luggage-compartment floor when it is fully open. You may otherwise damage the hinges of the EASY-PACK folding luggage-compartment floor.

- ❗ Vehicles with B&O sound system: do not remove the EASY-PACK folding floor. Removing the EASY-PACK folding floor will cause the cable set or the amplifier to be damaged because the amplifier module is screwed to the underside of the EASY-PACK folding floor.

Opening and closing the folding luggage-compartment floor

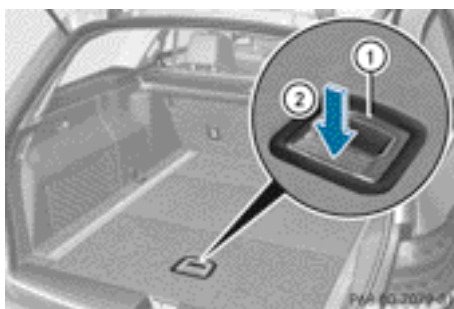

The parts of the EASY-PACK load-securing kit are contained beneath the EASY-PACK folding floor. Beneath the insert, you will find, for example, the TIREFIT kit or the emergency spare wheel and the vehicle tool kit.

- ▶ **To open:** open the tailgate.
- ▶ Holding the ribbing, press handle ① downwards ②. Handle ① folds upwards.



- ▶ Pull EASY-PACK folding luggage-compartment floor ③ in the direction of the arrow by handle ① until it reaches the desired position and engages in side ④.
- ▶ **To close:** disengage the EASY-PACK folding luggage-compartment floor and pull it back.
- ▶ Press the EASY-PACK folding luggage-compartment floor down ② until it engages.

Fitting and removing the folding luggage-compartment floor

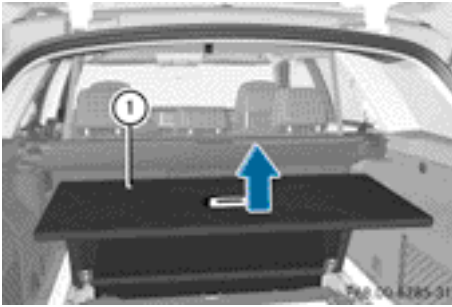

120° position

- ▶ Remove the combined luggage cover and net (▷ page 341).
- ▶ **To remove:** move EASY-PACK folding luggage-compartment floor ① into the 120° position and lift it upwards.
- ▶ **To install:** push EASY-PACK folding luggage-compartment floor ① to the stop, move it into the 120° position and make sure it engages audibly.
- ▶ Pull EASY-PACK folding luggage-compartment floor ① forwards.

EASY-PACK rear sill protector (Estate)

- ❗ Before closing the tailgate, refasten the EASY-PACK loading sill protector on the underside of the EASY-PACK folding luggage-compartment floor.
- The EASY-PACK loading sill protector could otherwise be damaged.

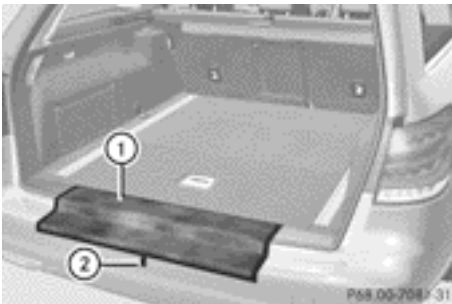

The EASY-PACK rear sill protector is attached to the underside of the EASY-PACK folding luggage-compartment floor by means of magnets. It is designed to prevent clothing becoming stained and the paintwork being scratched when loading.

- ▶ Open the EASY-PACK folding luggage-compartment floor (▷ page 346).
- ▶ Use tab ② to detach EASY-PACK rear sill protector ① from the magnets and place it over the loading sill.
- ▶ Close the EASY-PACK folding luggage-compartment floor.

Roof carrier

Important safety notes

⚠ WARNING

When a load is transported on the roof, the vehicle's centre of gravity rises and the handling changes. If you exceed the maximum roof load, the handling as well as steering and braking characteristics are severely affected. There is a risk of an accident.

Always observe the maximum roof load and adapt your driving style.

- ❗ Mercedes-Benz recommends that you only use roof carriers that have been tested and approved for Mercedes-Benz vehicles. This helps to prevent damage to the vehicle.

Position the load on the roof carrier in such a way that the vehicle will not sustain damage even when it is in motion.

Make sure that if the roof carrier is fitted:

- the sliding sunroof/panorama sliding sunroof can be fully raised, depending on the vehicle's equipment.
- the boot lid/ tailgate can be fully opened.
- the aerial on the roof does not touch the roof carrier.

! To avoid damaging or scratching the covers, do not use metallic or hard objects to open them.

The maximum roof load is 100 kg.

An incorrectly secured roof carrier or roof load may become detached from the vehicle. You must therefore ensure that you observe the roof carrier manufacturer's installation instructions.

Attaching the roof carrier (Saloon)

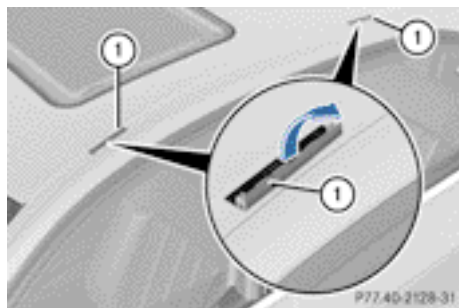

Vehicles with a steel roof or sliding sunroof (illustration)

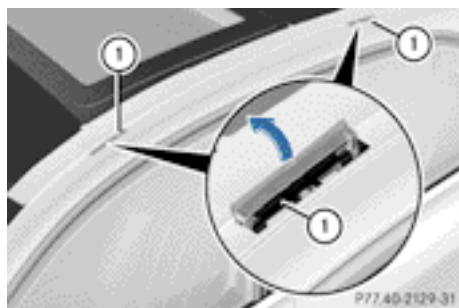

Vehicles with a panorama sliding sunroof

- ▶ Open covers ① carefully in the direction of the arrow.
- ▶ Fold covers ① upwards.
- ▶ Only secure the roof carrier to the anchor points under covers ①.
- ▶ Observe the manufacturer's installation instructions.

Attaching the roof carrier (Estate)

- ▶ Secure the roof carrier to the roof rails.
- ▶ Observe the manufacturer's installation instructions.

Features

Cup holders

Important safety notes

! Only use the cup holders for containers of the right size and which have lids. The drinks could otherwise spill.

Cup holders in the front centre console

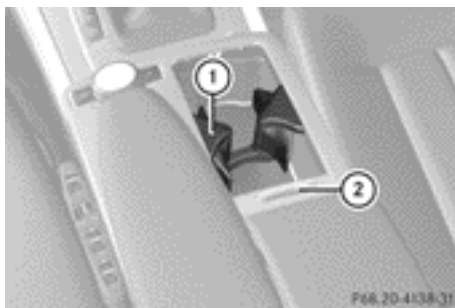

Vehicles with selector lever or gear lever

- ① Cup holders
- ② Cover

▶ **To open:** slide cover ② back.

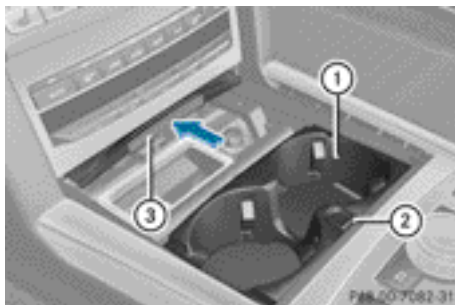

Vehicles with DIRECT SELECT lever

- ▶ **To open:** slide cover ③ forwards until it engages.
- ▶ **To remove:** slide catch ② forwards and pull out cup holder ①.
- ▶ **To insert:** insert cup holder ① and slide back catch ②.
- ▶ **To close:** briefly press cover ③ at the front. Cover ③ moves back.

You can remove the cup holder to clean it. Wash it with clean, lukewarm water only.

Cup holder in the rear seat armrest

- ❗ Do not sit on or support your body weight on the rear seat armrest when it is folded down, as you could otherwise damage it.
- ❗ Close the cup holder before folding the rear seat armrest up. Otherwise, the cup holder could be damaged.

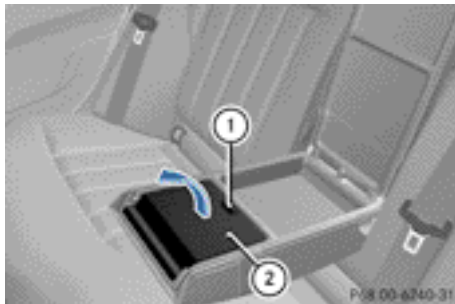

Vehicles with a rear bench seat

- ▶ Fold down the rear seat armrest.
- ▶ **To open:** raise the rear seat armrest cover.
- ▶ Press release catch ①. Cup holder ② folds out forwards.
- ▶ Fold the cover of the rear seat armrest back down again if necessary.
- ▶ **To close:** lift the cover of the rear seat armrest. Swing cup holder ② back until it engages.

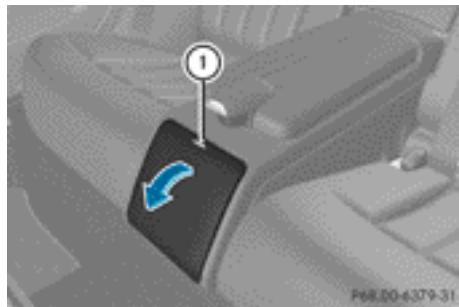

Vehicles with luxury single seats in the rear compartment

- ▶ **To open:** press lightly on the upper section of cup holder ① and fold down the cover.

Cup holder in the folding bench seat

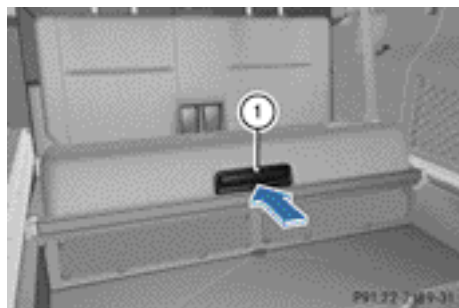

- ▶ **To open:** press the front of cup holder ①. Cup holder ① is released.
- ▶ Pull cup holder ① out to the stop.

Bottle holders

Observe the "Important safety notes" in the "Stowage compartments" section (▷ page 330).

⚠ WARNING

If objects in the passenger compartment are stowed incorrectly, they can slide or be thrown around and hit vehicle occupants. There is a risk of injury, particularly in the event of sudden braking or a sudden change in direction.

- Always stow objects so that they cannot be thrown around in such situations.
- Always make sure that objects do not protrude from stowage spaces, luggage nets or stowage nets.
- Close the lockable stowage spaces while driving.
- Always stow and secure heavy, hard, pointed, sharp-edged, fragile or bulky objects in the boot/luggage compartment.

! Make sure that any bottles weighing more than 0.5 kg that are stored in the bottle holder rest on the vehicle floor. The bottle holder could otherwise be damaged.

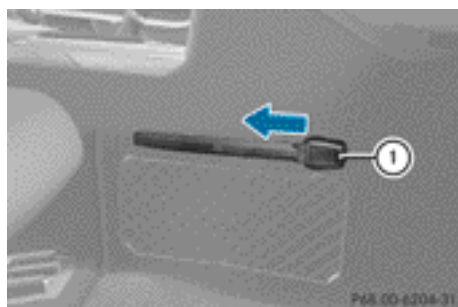

- ▶ Press the outer edge of button ① and slide in the direction of the arrow until the bottle fits into the opening.
- ▶ Insert the bottle into the bottle holder.

The bottle holder is suitable for bottles with a capacity from 0.7 l to 1.5 l.

The bottle holder does not secure bottles; it merely prevents them from tipping over.

Sun visors

Overview

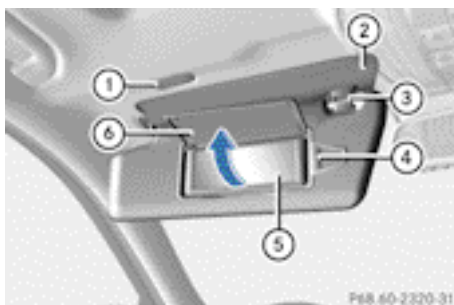

- ① Mirror light
- ② Additional sun visor
- ③ Bracket
- ④ Retaining clip, e.g. for a car park ticket
- ⑤ Vanity mirror
- ⑥ Mirror cover

Vanity mirror in the sun visor

Mirror light ① only functions if the sun visor is clipped into retainer ③ and mirror cover ⑥ has been folded up.

Glare from the side

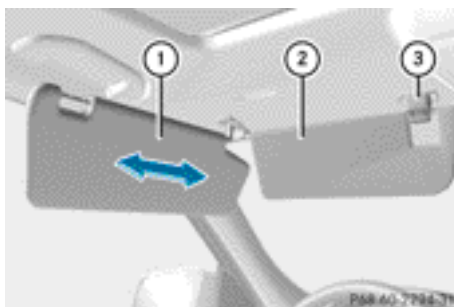

- ▶ Fold down sun visor ①.
- ▶ Pull sun visor ① out of retainer ③.
- ▶ Swing sun visor ① to the side.

- ▶ **Vehicles with an additional sun visor:** slide sun visor ① horizontally as desired.
- ▶ Fold down additional sun visor ② to the windscreen.

Sunblinds on the rear side windows

- ! Always guide the roller sunblind by hand. Do not let it snap back suddenly as this would damage the automatic roller mechanism.
- ! Do not drive the vehicle with the roller sunblind hooked in and the side windows opened simultaneously. The roller sunblind can jump out of the retainers and spring back suddenly when driving at high speeds, e.g. when driving on the motorway. This could damage the inertia reel. Therefore, either close the side window or retract the roller sunblind before driving at high speeds.

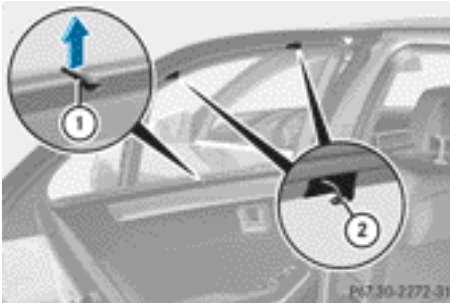

- ▶ **To extend:** pull the roller sunblind out by tab ① and hook it onto retainers ② at the top of the window.

Rear window roller sunblind (Saloon)

Important safety notes

WARNING

Parts of the body could be trapped in the sweep of the roller sunblind when the roller sunblind is extended or retracted. There is a risk of injury.

When extending or retracting make sure that no parts of the body are in the sweep of the roller sunblind. Briefly press the button again if someone becomes trapped. The opening/closing process is stopped.

- ! Make sure that the roller sunblind can move freely. Otherwise, the roller sunblind or other objects could be damaged.

Extending/retracting the roller sunblind

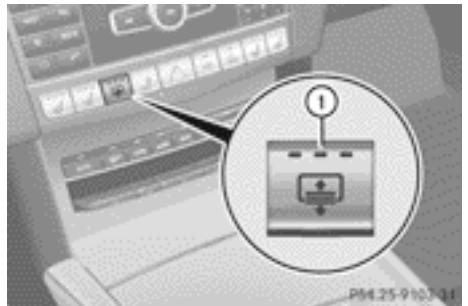

- ▶ Turn the key to position 2 in the ignition lock (▷ page 177).
- ▶ **To extend or retract:** briefly press button ①. The roller sunblind fully extends or fully retracts.
- ▶ **To stop:** briefly press button ① again. The roller sunblind stops briefly and moves back into the out-of-use position.

Ashtray

Front ashtray

- ! The stowage space under the ashtray is not heat resistant. Before placing lit cigarettes in the ashtray, make sure that the ashtray is properly engaged. Otherwise, the stowage space could be damaged.

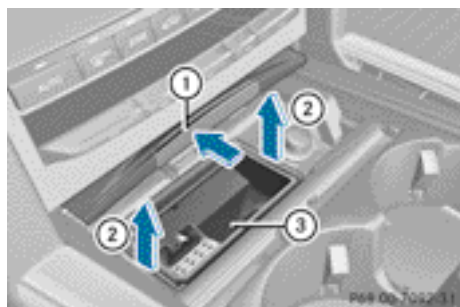

- ▶ **To open:** slide cover ① forwards until it engages.
- ▶ **To remove the insert:** hold insert ③ by the ribbing at the sides and lift it up ② and out.
- ▶ **To refit the insert:** press insert ③ into the holder until it engages.
- ▶ **To close:** briefly press cover ① at the front.
The cover moves back.

i You can remove the ashtray insert and use the resulting compartment for stowage.

Rear-compartment ashtray

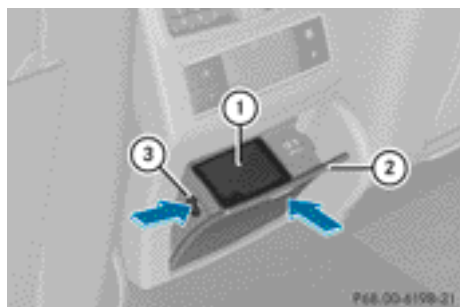

- ▶ **To open:** briefly press cover ② at the top.
The ashtray opens.
- ▶ **To remove the insert:** press release button ③ and lift the insert up and out.
- ▶ **To fit the insert:** fit insert ① from above into the holder and press down into the holder until it engages.

Cigarette lighter

⚠ WARNING

You can burn yourself if you touch the hot heating element or the socket of the cigarette lighter.

In addition, flammable materials can ignite if:

- the hot cigarette lighter falls
- a child holds the hot cigarette lighter to objects, for example

There is a risk of fire and injury.

Always hold the cigarette lighter by the knob. Always make sure that the cigarette lighter is out of reach of children. Never leave children unattended in the vehicle.

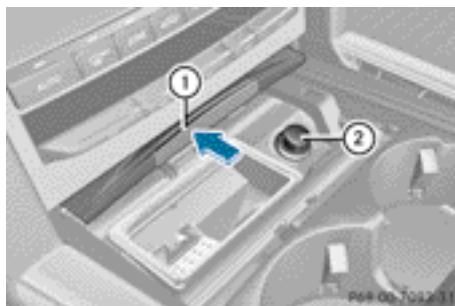

Your attention must always be focused on the traffic conditions. Only use the cigarette lighter when road and traffic conditions permit.

- ▶ Turn the key to position 2 in the ignition lock (▷ page 177).
- ▶ **To open:** slide cover ① forwards until it engages.
- ▶ Press in cigarette lighter ②.
Cigarette lighter ② will pop out automatically when the heating element is red-hot.
- ▶ **To close:** briefly press cover ① at the front.
The cover moves back.

12 V sockets

General notes

- ▶ Turn the key to position **1** in the ignition lock (▷ page 177).

The sockets can be used for accessories with a maximum draw of 180 W (15 A). Accessories include such items as bulbs or chargers for mobile phones.

If you use the sockets for long periods when the engine is switched off, the battery may discharge.

- i** An emergency cut-off ensures that the on-board voltage does not drop too low. If the on-board voltage is too low, the power to the sockets is automatically cut. This ensures that there is sufficient power to start the engine.

Socket in the front centre console



- ▶ **To open:** slide cover **1** forwards until it engages.
- ▶ Lift up the cover of socket **2**.
- ▶ **To close:** briefly press cover **1** at the front. The cover moves back.

Socket in the rear-compartment centre console

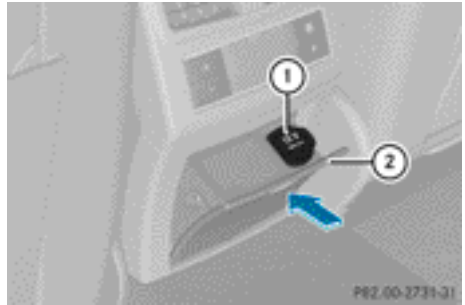

- ▶ Briefly press cover **2** at the top. The cover opens.
- ▶ Lift up the cover of socket **1**.

Socket in the luggage compartment



Power socket in the luggage compartment (Estate)

- ▶ Lift up the cover of socket **1**.

Mobile phone

Important safety notes

⚠ WARNING

Operating mobile communications equipment while driving distracts you from paying attention to traffic conditions. This could also cause you to lose control of the vehicle. There is a risk of an accident.

Use this device only when the vehicle is stationary.

i You must observe the legal requirements for the country in which you are currently driving when operating mobile communications equipment in the vehicle.

If it is permitted by law to operate communications equipment while the vehicle is in motion, you may only do so if the traffic situation permits. You may otherwise be distracted from the traffic conditions, cause an accident and injure yourself and others.

Excessive levels of electromagnetic radiation may cause damage to your health and to the health of others. The use of an exterior aerial takes into consideration the scientific discussion surrounding the possible health risk posed by electromagnetic fields.

Mercedes-Benz recommends the use of an approved exterior aerial. This ensures:

- optimal mobile phone reception quality in the vehicle.
- mutual interference between the vehicle electronics and mobile phones is minimised.

An exterior aerial has the following advantages:

- it conducts the electromagnetic fields generated by a wireless device to the exterior.
- the field strength in the vehicle interior is lower than in a vehicle that does not have an exterior aerial.

Information on retrofitting two-way radios and mobile phones (RF transmitters) (▷ page 466).

General notes

There are various mobile phone brackets that may be fitted in your vehicle; in some cases, these are country-specific.

You can connect a Bluetooth®-capable mobile phone with Audio 20 or COMAND Online via the Bluetooth® interface. This also applies if your vehicle is equipped with convenience telephony.

More information on suitable mobile phones, mobile phone brackets and on connecting Bluetooth®-capable mobile phones with Audio 20 or COMAND Online can be obtained:

- at your Mercedes-Benz Service Centre
- on the Internet at <http://www.mercedes-benz.com/connect>



i The functions and services available when you use the phone depend on your mobile phone model and service provider.

Using a mobile phone

If the mobile phone is inserted in the mobile phone bracket, the mobile phone will be charged and connected with the exterior aerial.

- ▶ Open the telephone compartment (▷ page 332).
- ▶ Place the mobile phone bracket into the pre-installed fitting (see the separate installation instructions for the mobile phone fitting).
- ▶ Insert the mobile phone into the mobile phone bracket (see the separate installation instructions for the mobile phone fitting).

Operating the mobile phone

You can operate the telephone using the  and  buttons on the multifunction steering wheel. You can operate other mobile phone functions via the on-board computer (▷ page 276).

When you remove the key from the ignition lock, the mobile phone is disconnected from the hands-free system. Active calls will first be transferred to the mobile phone directly.

Mobile phone bracket in the stowage compartment

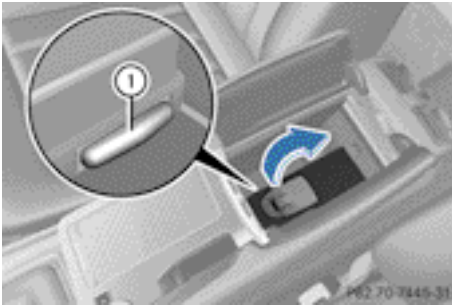

You can fold the pre-installed bracket up to improve access to the stowage space beneath it. Depending on the vehicle's equipment, a USB connection and an AUX-IN connection/Media Interface are fitted in the stowage compartment.

- ▶ **To fold the bracket up:** press button ①.
- ▶ **To fold the bracket down:** press the bracket down and allow it to engage.

Garage door opener

Important safety notes

⚠ WARNING

When you operate or program the garage door with the integrated garage door opener, persons in the range of movement of the garage door can become trapped or struck by the garage door. There is a risk of injury.

When using the integrated garage door opener, always make sure that nobody is within the range of movement of the garage door.

⚠ WARNING

Combustion engines emit poisonous exhaust gases such as carbon monoxide. Inhaling these exhaust gases leads to poisoning. There is a risk of fatal injury. Therefore never leave the engine running in enclosed spaces without sufficient ventilation.

The HomeLink® garage door opener integrated in the rear-view mirror allows you to operate up to three different door and gate systems.

When programming a garage door opener, park the vehicle outside the garage.

- ❗ The garage door opener is only available for certain countries. Observe the legal requirements for each individual country. The HomeLink® garage door opener is compatible with most European garage and gate opener drives. More information on HomeLink® and/or compatible products is available:
 - at a qualified specialised workshop
 - via the HomeLink® Hotline (0) 08000 466 354 65 or alternatively +49 (0) 6838 907-277
 - on the Internet at: <http://www.homelink.com>

Programming

Programming buttons

Observe the "Important safety notes" (▷ page 355).

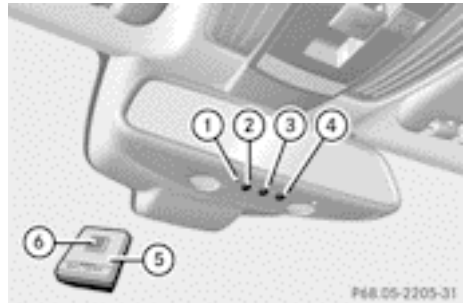

Integrated garage door opener in the rear-view mirror

Garage door remote control ⑤ is not part of the integrated garage door opener.

- ▶ Before programming for the first time, clear the memory of the integrated garage door opener (▷ page 357).
- ▶ Turn the key to position **2** in the ignition lock.
- ▶ Press and hold one of buttons **②** to **④** on the integrated garage door opener. After a short time, indicator lamp **①** begins to light up yellow.
 - i** Indicator lamp **①** lights up yellow immediately the first time button **②**, **③** or **④** is programmed. If the selected button has already been programmed, indicator lamp **①** lights up yellow after ten seconds have elapsed.
- ▶ Release button **②**, **③** or **④**. Indicator lamp **①** flashes yellow.
- ▶ Point garage door remote control **⑤** towards buttons **②** to **④** on the rear-view mirror at a distance of 5 to 20 cm.
 - i** The required distance between remote control **⑤** and the integrated garage door opener depends on the garage door drive system. Several attempts may be required. You should test every position for at least 25 seconds before trying another position.
- ▶ Press and hold button **⑥** on remote control **⑤** until indicator lamp **①** lights up green. If indicator lamp **①** lights up green or flashes, then programming has been successful.
- ▶ Release button **⑥** of remote control **⑤** of the garage door drive.
- ▶ If indicator lamp **①** blinks red: repeat the programming process for the corresponding button on the rear-view mirror. When doing so, vary the distance between remote control **⑤** and the rear-view mirror.
 - i** If the indicator lamp flashes green after successful programming, the garage door system is using a rolling code. After programming, you must synchronise the garage door opener integrated in the rear-

view mirror with the receiver of the garage door system.

Synchronising the rolling code

Observe the "Important safety notes" (▷ page 355).

Your vehicle must be within range of the garage door or exterior gate drive. Make sure that neither your vehicle nor any persons/objects are present within the sweep of the door or gate.

- ▶ Turn the key to position **2** in the ignition lock.
- ▶ Press the programming button of the door or gate drive (see the door or gate drive operating instructions, e.g. under "Programming of additional remote controls").
 - i** Usually, you now have 30 seconds to initiate the next step.
- ▶ Press previously programmed button **②**, **③** or **④** of the integrated garage door opener until the door closes. The rolling code synchronisation is then complete.

Problems when programming

If you have problems when programming the integrated garage door opener, please note the following:

- Check the transmitter frequency of garage door drive remote control **⑤**. This can usually be found on the back of the remote control.
- Replace the batteries in garage door remote control **⑤**. This increases the likelihood that garage door remote control **⑤** will transmit a strong and precise signal to the integrated garage door opener in the rear-view mirror.
- When programming, hold remote control **⑤** at varying distances and angles from the button which you are programming. Try various angles at a distance between 5 and 30 cm or at the same angle but at varying distances.

- If there is another remote control for the same garage door drive, perform the programming steps again using this remote control. Before performing these steps, make sure that new batteries have been fitted in garage door drive remote control ⑤.
- Note that some remote controls transmit only for a limited period (the indicator lamp on the remote control goes out). Press button ⑥ on remote control ⑤ again before transmission ends.
- Align the aerial cable of the garage door opener unit. This can improve signal reception/transmission.

Opening or closing the garage door

Once programmed, the integrated garage door opener will assume the function of the garage door system's remote control. Please also read the operating instructions for the garage door system.

- ▶ Turn the key to position **2** in the ignition lock.
- ▶ Press button ②, ③ or ④ which you have programmed to operate the garage door. Garage door system with a fixed code: indicator lamp ① lights up green.
Garage door system with a rolling code: indicator lamp ① flashes green.

- ① The transmitter will transmit a signal for as long as the button is pressed. The transmission is halted after a maximum of ten seconds and indicator lamp ① lights up yellow. Press button ②, ③ or ④ again if necessary.

Clearing the memory

- ▶ Turn the key to position **2** in the ignition lock.
- ▶ Press buttons ② and ④.
The indicator lamp lights up yellow.
- ▶ Press and hold buttons ② and ④ until the indicator lamp turns green.

- ① Make sure that you clear the memory of the integrated garage door opener before selling the vehicle.

Frequencies

Europe

Country	Radio type approval number Frequency range (MHz)
AD (Andorra)	20 July 2005 MHz: 27, 30, 40, 433, 868
AT (Austria)	Article 6 of Directive 1999/5/EC R&TTE 18 May 05 MHz: 27, 40, 433, 868
BE (Belgium)	Article 6 of Directive 1999/5/EC R&TTE 18 May 05 MHz: 27, 40, 433, 868
BG (Bulgaria)	Article 6 of Directive 1999/5/EC R&TTE 12 April 07 MHz: 27, 40, 433, 868
CH (Switzerland)	Article 6 of Directive 1999/5/EC R&TTE 14357 27 May 05 MHz: 27, 40, 433, 868
CY (Cyprus)	Article 6 of Directive 1999/5/EC R&TTE 5 May 05 MHz: 27, 40, 433, 868
CZ (Czech Republic)	General Licence GL-30/R/2000 Reg No. 844 13 May 05 MHz: 27, 40, 433
DK (Denmark)	Article 6 of Directive 1999/5/EC R&TTE 20 April 05 MHz: 27, 40, 433, 868

Country	Radio type approval number Frequency range (MHz)
DE (Germany)	Article 6 of Directive 1999/5/EC R&TTE 75 19301 29 April 05 MHz: 27, 40, 433, 868
EE (Estonia)	Article 6 of Directive 1999/5/EC R&TTE 11 May 05 MHz: 27, 40, 433, 868
ES (Spain)	000438/2005, 000439/2005, 000440/2005 000441/2005, 000445/2005, 000446/2005 000447/2005 MHz: 27, 40, 433, 868
FI (Finland)	Article 6 of Directive 1999/5/EC R&TTE 10668 13 May 05 MHz: 27, 40, 433, 868
FR (France)	Article 6 of Directive 1999/5/EC R&TTE 10668 13 May 05 27, 30, 40, 433, 868
GI (Gibraltar)	Article 6 of Directive 1999/5/EC R&TTE 10668 13 May 05 (UK) MHz: 27, 40, 418, 433, 868
GR (Greece)	Article 6 of Directive 1999/5/EC R&TTE 11409/18/4/2005 18 May 05 MHz: 27, 40, 433, 868
HR (Croatia)	SDR 224/06 MHz: 27, 40, 433, 868

Country	Radio type approval number Frequency range (MHz)
HU (Hungary)	Article 6 of Directive 1999/5/EC R&TTE 18 May 05 MHz: 27, 40, 433, 868
IC (Canary Islands)	000438/2005, 000439/2005 000440/2005, 000441/2005 000445/2005, 000446/2005 000447/2005, 3rd June 2005 MHz: 27, 40, 433, 868
IE (Ireland)	Article 6 of Directive 1999/5/EC R&TTE 18 May 05 MHz: 27, 40, 433, 868
IS (Iceland)	Article 6 of Directive 1999/5/EC R&TTE 18 May 05 MHz: 27, 40, 433, 868
IT (Italy)	DGPGSR/II/347487/ FOR/15347 DGPGSR/II/347487/ FOR/15348 DGPGSR/II/347487/ FOR/15350 DGPGSR/II/347487/ FOR/15357 DGPGSR/II/347487/ FOR/15358 DGPGSR/II/347487/ FOR/15359 MHz: 27, 40, 433, 868
LI (Liechtenstein)	Article 6 of Directive 1999/5/EC R&TTE 14357 27 May 05 MHz: 27, 40, 433, 868

Country	Radio type approval number Frequency range (MHz)
LT (Lithuania)	Article 6 of Directive 1999/5/EC R&TTE 27.4-1B-1609 6 May 05 MHz: 27, 40, 433, 868
LU (Luxembourg)	Article 6 of Directive 1999/5/EC R&TTE 150405/9538 24 May 05 MHz: 27, 40, 433, 868
LV (Latvia)	Article 6 of Directive 1999/5/EC R&TTE 27.4-1B-1609 26 April 06 MHz: 27, 40, 433, 868
MC (Monaco)	Article 6 of Directive 1999/5/EC R&TTE 10668 13 May 05 MHz: 27, 40, 433, 868
MT (Malta)	Article 6 of Directive 1999/5/EC R&TTE 18 May 05 MHz: 27, 40, 433, 868
NL (Netherlands)	Article 6 of Directive 1999/5/EC R&TTE 18 May 05 MHz: 27, 40, 433, 868
NO (Norway)	Article 6 of Directive 1999/5/EC R&TTE 05/02424-SA644 18 May 05 MHz: 27, 40, 433, 868
PL (Poland)	Article 6 of Directive 1999/5/EC R&TTE 21 April 05 MHz: 27, 40, 433, 868
PT (Portugal)	ANCOM-S08399/05 27, 40, 433, 868

Country	Radio type approval number Frequency range (MHz)
RO (Romania)	Article 6.4 of Directive 1999/5/EC R&TTE MHz: 27, 30, 40, 433, 868
RU (Russian Federation)	POCC DE.MJ05.H00015 13 May 05 MHz: 433
SE (Sweden)	Article 6 of Directive 1999/5/EC R&TTE 18 May 05 MHz: 27, 40, 433, 868
SI (Slovenia)	Article 6 of Directive 1999/5/EC R&TTE 500-1/2005-437 9 May 05 MHz: 27, 40, 433, 868
SK (Slovakia)	Article 6 of Directive 1999/5/EC R&TTE Slovak 206/11/2005 4 May 05 MHz: 27, 40, 433, 868
UK (United Kingdom)	Article 6 of Directive 1999/5/EC R&TTE 18 May 05 MHz: 27, 40, 418, 433, 868

Africa

Country	Radio type approval number Frequency range (MHz)
EG (Egypt)	W-KLE-17/08 Mar. 06 MHz: 27, 30, 40, 418, 433, 868
RE (Réunion)	Article 6 of Directive 1999/5/EC R&TTE 11 July 05 MHz: 27, 40, 433, 868
ZA (South Africa)	11 October 2005 MHz: 27, 40, 433

America

Country	Radio type approval number Frequency range (MHz)
BB (Barbados)	Registration not required MHz: 27, 40, 433, 868
CL (Chile)	38447/F-23 No.3.3634 MHz: 40, 433 3943/DFRS05165/F-50 MHz: 280 to 433
GF (French Guyana)	Article 6 of Directive 1999/5/EC R&TTE 10668 13 May 05 MHz: 27, 30, 40, 433, 868
GP (Guadeloupe)	Article 6 of Directive 1999/5/EC R&TTE 10668 13 May 05 MHz: 27, 30, 40, 433, 868
MQ (Martinique)	Article 6 of Directive 1999/5/EC R&TTE 11 July 05 MHz: 27, 30, 40, 433, 868
MX (Mexico)	MHz: 280 to 390

Asia

Country	Radio type approval number Frequency range (MHz)
AE (United Arab Emirates)	1623/5/10-2/26/76 MHz: 433
JO (Jordan)	TRC/LPD/2005/23 MHz: 27, 30, 40, 433, 868
KW (Kuwait)	5 October 2005 MHz: 27, 30, 40, 418, 433, 868
SA (Saudi Arabia)	11_02_05/5024-5-6 MHz: 418, 433
SY (Syria)	279/4/14 / 05 March 06
TR (Turkey)	National Certification 23 July 07 MHz: 433

Australia

Country	Radio type approval number Frequency range (MHz)
AU (Australia)	28 June 2005 MHz: 27, 30, 40, 433, 868
NZ (New Zealand)	20 March 06 MHz: 27, 30, 40, 433

Floor mats

 **WARNING**

Objects in the driver's footwell may restrict the clearance around the pedals or block a depressed pedal. This jeopardises the operating and road safety of the vehicle. There is a risk of an accident.

Stow all objects securely in the vehicle so that they do not get into the driver's footwell. Always fit the floor mats securely and as pre-

scribed in order to ensure that there is always sufficient room for the pedals. Do not use loose floormats and do not place several floormats on top of one another.

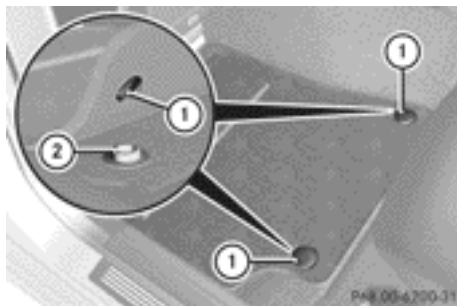

- ▶ Slide the seat backwards.
- ▶ **To fit:** lay the floormat in the footwell.
- ▶ Press studs ① onto retainers ②.
- ▶ **To remove:** pull the floormat away from retainers ②.
- ▶ Remove the floormats.

Retrofitted anti-glare film

Retrofitted anti-glare film on the inside of the windows can interfere with radio/mobile telephone reception. This is particularly the case for conductive or metallic-coated films. You can obtain information about anti-glare film from a qualified specialist workshop.

Useful information	364
Engine compartment	364
Service	370
Care	371

Useful information

- i** This Owner's Manual describes all models, series and optional equipment for your vehicle that were available at the time of going to press. National variations are possible. Note that your vehicle may not be equipped with all of the functions described. This is also the case for systems and functions relevant to safety.
- i** Read the information on qualified specialist workshops: (▷ page 26).

Engine compartment

Bonnet

Important safety notes

WARNING

An unlocked bonnet may open while driving and block your view. There is a risk of an accident.

Never unlock the bonnet while driving.

WARNING

When being opened and closed, the bonnet may suddenly fall into the closed position. There is a risk of injury to persons in the range of movement of the bonnet.

Open and close the bonnet only when nobody is in the range of movement.

WARNING

If you open the bonnet while the engine is overheating or while there is a fire in the engine compartment, you could come into contact with hot gases or other leaking service products. There is a danger of injury. Allow an overheating engine to cool down before opening the bonnet. If there is a fire in the engine compartment, leave the bonnet closed and notify the fire brigade.

WARNING

There are parts in the engine compartment that move. Certain components may continue to run even if the ignition is switched off or may suddenly start again, e.g. the radiator fan. There is a danger of injury.

If you need to access the engine compartment:

- switch off the ignition
- never enter the danger area of moving components, e.g. the rotation area of the fan
- keep items of clothing away from moving parts

WARNING

The ignition system and the fuel injection system operate with a high voltage. If you touch the live components, you could receive an electric shock. There is a danger of injury.

Never touch components of the ignition system or the fuel injection system when the ignition is switched on.

WARNING

Hybrid vehicles: ensure that you read the "HYBRID" supplement. You could otherwise fail to recognise dangers.

Active bonnet (pedestrian protection)

Operating principle

- !** An active bonnet that had been triggered must be repaired at a qualified specialist workshop. The active bonnet function will then be available again. The additional pedestrian protection provided by the active bonnet will then be restored.
- !** Do not try to press down the raised bonnet at the back. Otherwise, the bonnet could be damaged.
- i** The active bonnet is only available in certain countries. It is available for all models, except for AMG vehicles.

The active bonnet can reduce the risk of injury to pedestrians in certain accident situations. Raising the active bonnet increases the clearance to hard components, such as the engine.

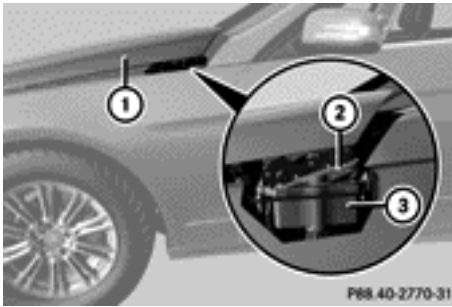

If active bonnet ① has been triggered, it will be raised at the back by about 50 mm. Lids ② will then no longer rest on housings ③. The active bonnet is triggered by pyrotechnics.

You can reset a triggered active bonnet yourself.

Even if the active bonnet has been triggered, you can still continue driving and have it reset at a qualified specialist workshop. If you pull the bonnet release lever, you must reset the bonnet before driving on.

Resetting

WARNING

Certain components in the engine compartment could be very hot, e.g. the engine, the radiator and parts of the exhaust system. There is a risk of injury when accessing the engine compartment.

As far as possible, allow the engine to cool down and only touch the following components.

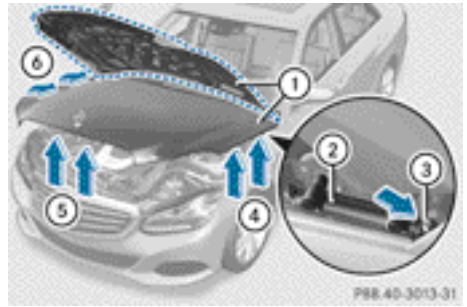

- ▶ Open the bonnet (▷ page 366).
- ▶ With both hands, lift the bonnet up in the centre ⑤. The bonnet is open wide enough when both lids of bonnet lifter ② no longer move.

If you push the lids back, you will notice resistance.

- ▶ Release bonnet ①.
- ▶ Check whether the lids of bonnet lifter ② are resting on housings ③ (arrow).
- ▶ **The lids of bonnet lifter ② are resting on the housings:** close bonnet ① (▷ page 366).

or

- ▶ **The lids of bonnet lifter ② are not resting on the housings:** first, lift up bonnet ① on left-hand side ④ and then on right-hand side ⑥. Lift up bonnet ① until the respective lid of bonnet lifter ② no longer moves. The lids of bonnet lifter ② must rest on housings ③ (arrow).
- ▶ Close bonnet ① (▷ page 366).

If you cannot close bonnet ① or if the  symbol appears in the multifunction display, repeat the steps.

If the bonnet still does not engage correctly or the  symbol appears in the multifunction display, do not drive any further. Contact a qualified specialist workshop.

If active bonnet ① has been triggered, it will be raised at the back by about 50 mm. Lids ② will then no longer rest on housings

- ③. The active bonnet is triggered by pyrotechnics.

Opening the bonnet

WARNING

Certain components in the engine compartment could be very hot, e.g. the engine, the radiator and parts of the exhaust system. There is a risk of injury when accessing the engine compartment.

As far as possible, allow the engine to cool down and only touch the following components.

WARNING

When the bonnet is open, and the windscreen wipers are set in motion, you can be injured by the wiper linkage. There is a risk of injury. Always switch off the windscreen wipers and the ignition before opening the bonnet.

-  Make sure that the windscreen wipers are not folded away from the windscreen. Otherwise, you could damage the windscreen wipers or the bonnet.

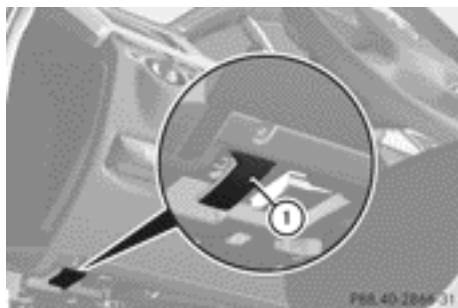

- ▶ Make sure that the windscreen wipers are switched off.
- ▶ Pull release lever ① on the bonnet. The bonnet is released.

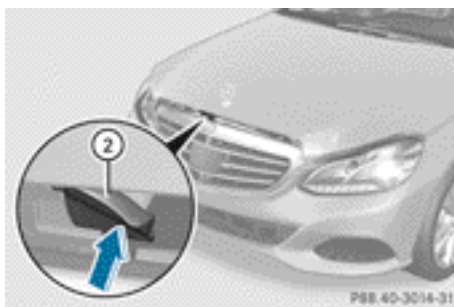

- ▶ Reach into the gap, pull bonnet catch handle ② up and lift the bonnet.

If you lift the bonnet by approximately 40 cm, the bonnet is opened and held open automatically by the gas-filled strut.

Closing the bonnet

- ▶ Lower the bonnet and let it fall from a height of approximately 20 cm.
- ▶ Check that the bonnet has engaged properly. If the bonnet can be raised slightly, it is not properly engaged. Open it again and close it with a little more force.

Radiator

Vehicles with a diesel engine: do not cover the radiator. Do not use thermal mats, insect protection covers or anything similar. Doing so can cause the Onboard Diagnostics System to display inaccurate values. Some of these values are legally required and must always be correct.

Engine oil

General notes

WARNING

Hybrid vehicles: ensure that you read the "HYBRID" supplement. You could otherwise fail to recognise dangers.

Depending on your driving style, the vehicle consumes up to 0.8 litres of oil per 1,000 km. The oil consumption may be higher than this when the vehicle is new or if you frequently drive at high engine speeds.

Depending on the engine, the oil dipstick may be installed at a different location.

When checking the oil level:

- park the vehicle on a level surface.
- the engine should be switched off for approximately five minutes if the engine is at normal operating temperature.
- if the engine is not at normal operating temperature, e.g. if the engine was only started briefly, wait about 30 minutes before carrying out the measurement.

Checking the oil level using the oil dipstick

WARNING

Certain components in the engine compartment could be very hot, e.g. the engine, the radiator and parts of the exhaust system. There is a risk of injury when accessing the engine compartment.

As far as possible, allow the engine to cool down and only touch the following components.

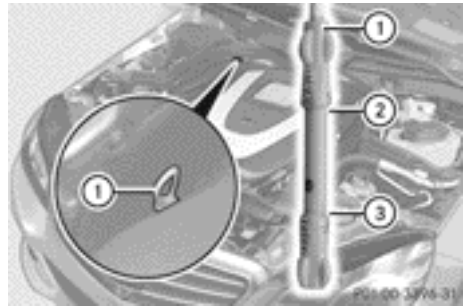

Example: vehicles with a petrol engine



Example: vehicles with a diesel engine

- ▶ Pull oil dipstick ① out of the oil dipstick tube.
- ▶ Wipe off oil dipstick ①.
- ▶ Slowly slide oil dipstick ① into the guide tube to the stop, and take it out again. If the level is between MIN mark ③ and MAX mark ②, the oil level is correct.
- ▶ If the oil level has dropped to MIN mark ③ or below, top up with 1.0 l of engine oil.

Adding engine oil

WARNING

Certain components in the engine compartment could be very hot, e.g. the engine, the radiator and parts of the exhaust system. There is a risk of injury when accessing the engine compartment.

As far as possible, allow the engine to cool down and only touch the following components.

⚠ WARNING

If engine oil comes into contact with hot components in the engine compartment, it may ignite. There is a risk of fire and injury.

Make sure that engine oil does not spill out over the filler neck. Allow the engine to cool down and thoroughly clean the components that have come into contact with engine oil before you start the engine.

🌿 Environmental note

When topping up the oil, take care not to spill any. If oil enters the soil or waterways, it is harmful to the environment.

- !** Only use engine oils and oil filters that have been approved for vehicles with a service system. You can obtain a list of the engine oils and oil filters tested and approved in accordance with the Mercedes-Benz Specifications for Service Products at any Mercedes-Benz Service Centre.

Damage to the engine or exhaust system is caused by the following:

- using engine oils and oil filters that have not been specifically approved for the service system
- changing the engine oil and oil filter after missing the change interval required by the service system
- using engine oil additives

- !** Do not add too much oil. Topping up with too much engine oil can result in damage to the engine or to the catalytic converter. Have excess engine oil siphoned off.



Example: engine oil filler cap

- ▶ Turn cap ① anti-clockwise and remove it.
- ▶ Top up the engine oil.
If the oil level is at or below the MIN mark on the oil dipstick, top up with 1.0 l of engine oil.
- ▶ Replace cap ① on the filler neck and turn clockwise.
Make sure that the cap locks securely into place.
- ▶ Check the oil level again with the oil dipstick (▷ page 367).

For further information on engine oil, see (▷ page 474).

Other service products**Checking the coolant level****⚠ WARNING**

Certain components in the engine compartment could be very hot, e.g. the engine, the radiator and parts of the exhaust system. There is a risk of injury when accessing the engine compartment.

As far as possible, allow the engine to cool down and only touch the following components.

⚠ WARNING

The engine cooling system is under pressure, particularly if the engine is warm. You could be scalded by hot coolant spraying out when opening the cap. There is a danger of injury.

Allow the engine to cool before opening the cap. Wear gloves and protective eyewear when opening. Slowly turn the cap half a turn to allow pressure to escape.

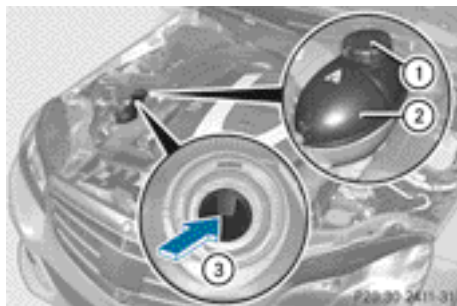

- ▶ Park the vehicle on a level surface. Only check the coolant level if the vehicle is on a level surface and the engine has cooled down.

- ▶ Turn the key to position **2** in the ignition lock (▷ page 177).

On vehicles with KEYLESS-GO, press the Start/Stop button twice (▷ page 177).

- ▶ Check the coolant temperature display in the instrument cluster.

The coolant temperature must be below 70 °C.

- ▶ Turn the key to position **0** (▷ page 177) in the ignition lock.

- ▶ Slowly turn cap ① half a turn anti-clockwise to allow excess pressure to escape.

- ▶ Turn cap ① further anti-clockwise and remove it.

If the coolant is at the level of marker bar ③ in the filler neck when cold, there is enough coolant in coolant expansion tank ②.

If the coolant level is approximately 1.5 cm above marker bar ③ in the filler neck when warm, there is enough coolant in coolant expansion tank ②.

- ▶ If necessary, top up with coolant that has been tested and approved by Mercedes-Benz.
- ▶ Replace cap ① and turn it clockwise as far as it will go.

For further information on coolant, see (▷ page 475).

Topping up the windscreen washer system

⚠ WARNING

Certain components in the engine compartment could be very hot, e.g. the engine, the radiator and parts of the exhaust system. There is a risk of injury when accessing the engine compartment.

As far as possible, allow the engine to cool down and only touch the following components.

⚠ WARNING

Windscreen washer concentrate is highly flammable. If it comes into contact with hot engine components or the exhaust system it could ignite. There is a risk of fire and injury.

Make sure that no windscreen washer concentrate is spilled next to the filler neck.



- ▶ **To open:** pull cap ① upwards by the tab.
- ▶ Top up with the premixed washer fluid.
- ▶ **To close:** press cap ① onto the filler neck until it engages.

If the washer fluid level drops below the recommended minimum of 1 litre, a message

appears in the multifunction display prompting you to top up the washer fluid (▷ page 317).

Further information on windscreen washer fluid/antifreeze (▷ page 476).

Service

ASSYST PLUS

Service messages

The ASSYST PLUS service interval display informs you of the next service due date.

Information on the type of service and service intervals (see separate Service Booklet).

You can obtain further information from a Mercedes-Benz Service Centre.

i The ASSYST PLUS service interval display does not show any information on the engine oil level. Observe the notes on the engine oil level (▷ page 366).

The multifunction display shows a service message for a few seconds, e.g.:

- Service A in .. days
- Service A due
- Service A overdue by .. days

Depending on the operating conditions of the vehicle, the remaining time or distance until the next service due date is displayed.

The letter indicates which service is due. **A** stands for a minor service and **B** for a major service. A number or another letter may be displayed after the letter. This figure indicates any necessary additional maintenance work to be performed.

If you notify a qualified specialist workshop of this display, you will receive a statement on the associated costs.

The ASSYST PLUS service interval display does not take into account any periods of time during which the battery is disconnected.

Maintaining the time-dependent service schedule:

▶ Note down the service due date displayed in the multifunction display before disconnecting the battery.

or

▶ After reconnecting the battery, subtract the battery disconnection periods from the service date shown on the display.



Hiding a service message

▶ Press the  or  button on the steering wheel.

Displaying service messages

▶ Switch the ignition on.

▶ Press the  or  button on the steering wheel to select the **Serv.** menu.

▶ Press the  or  button to select the **ASSYST PLUS** submenu and confirm by pressing the  button.

The service due date appears in the multifunction display.

Information about Service

Resetting the ASSYST PLUS service interval display

! If the ASSYST PLUS service interval display has been inadvertently reset, this setting can be corrected at a qualified specialist workshop.

Have service work carried out as described in the Service Booklet. This may otherwise lead to increased wear and damage to the major assemblies or the vehicle.

A qualified specialist workshop, e.g. a Mercedes-Benz Service Centre, will reset the ASSYST PLUS service interval display after the service work has been carried out. You can also obtain further information on maintenance work, for example.

Special service requirements

The prescribed service interval is based on normal operation of the vehicle. Service work will need to be performed more often if the vehicle is operated under arduous conditions or increased loads, for example:

- regular city driving with frequent intermediate stops
- if the vehicle is primarily used to travel short distances
- for frequent operation in mountainous terrain or on poor road surfaces
- if the engine is often left idling for long periods

In these or similar operating conditions, have the air filter, engine oil and oil filter, for example, changed more frequently. The tyres must be checked more frequently if the vehicle is operated under increased loads. Further information can be obtained at a qualified specialist workshop, e.g. a Mercedes-Benz Service Centre.

Driving abroad

An extensive Mercedes-Benz Service network is also available in other countries. The Service Hotline's current telephone numbers for use when you are abroad are to be found in the "Mercedes-Benz Service24h" section of the Service Booklet.

AdBlue® service indicator

i For BlueTEC vehicles only.

To function properly, BlueTEC exhaust gas aftertreatment must be operated with the reducing agent AdBlue®. AdBlue® is topped up as part of the service. Under normal operating conditions, a full tank of AdBlue® should last until the next service due date.

Depending on how and where the vehicle is used, there may be an increase in the AdBlue® consumption, resulting in the next service due date being brought forward.

Certain display messages show that AdBlue® must be topped up, e.g.:

Refill AdBlue at workshop See Owner's Manual

Refill AdBlue at workshop No start in .. km

A warning signal also sounds.

You can no longer start the engine when the AdBlue® supply has been used up (> page 303).

! Have the AdBlue® tank topped up at a qualified specialist workshop only. The vehicle may otherwise be damaged or soiled.

Before taking a trip with your vehicle outside Europe, have the AdBlue® supply checked at a qualified specialist workshop. If necessary, have AdBlue® topped up. Before a longer stay outside of Europe, consult a qualified specialist workshop.

Observe the notes on AdBlue® (> page 473). Further information about BlueTEC exhaust gas aftertreatment and AdBlue® can be obtained at a qualified specialist workshop, e.g. a Mercedes-Benz Service Centre.

Care

General notes

Environmental note

Dispose of empty packaging and cleaning cloths in an environmentally responsible manner.

! For cleaning your vehicle, do not use any of the following:

- dry, rough or hard cloths
- abrasive cleaning agents
- solvents
- cleaning agents containing solvents

Do not scrub.

Do not touch the surfaces or protective films with hard objects, e.g. a ring or ice

scraper. You could otherwise scratch or damage the surfaces and protective film.

- ❗ Do not park up the vehicle for an extended period straight after cleaning it, particularly after having cleaned the wheels with wheel cleaner. Wheel cleaners could cause increased corrosion of the brake discs and brake pads/linings. For this reason, you should drive for a few minutes after cleaning. Braking heats the brake discs and the brake pads/linings, thus drying them. The vehicle can then be parked up.

Regular care of your vehicle is a condition for retaining the quality in the long term.

Use care products and cleaning agents recommended and approved by Mercedes-Benz.

Washing the vehicle and cleaning the paintwork

Automatic car wash

WARNING

Braking efficiency is reduced after the vehicle has been washed. There is a risk of an accident.

After washing the vehicle, brake carefully while paying attention to the traffic conditions in order to restore full braking efficiency.

- ❗ If DISTRONIC PLUS or the HOLD function is activated, the vehicle brakes automatically in certain situations. To prevent damage to the vehicle, deactivate DISTRONIC PLUS and the HOLD function in the following or other similar situations:

- when towing the vehicle
- in the car wash

- ❗ Make sure that:

- the side windows and sliding sunroof are closed completely.
- the blower for the ventilation/heating is switched off (OFF button is depressed).
- the windscreen wiper switch is at position **0**.

The vehicle could otherwise be damaged.

- ❗ In car washes with a towing mechanism, make sure that the automatic transmission is in transmission position **N**; otherwise, the vehicle could be damaged.

- Vehicles with DIRECT SELECT lever and key:

do not remove the key from the ignition lock. Do not open the driver's door or front-passenger door when the engine is switched off. Otherwise, the automatic transmission selects park position **P** automatically and locks the wheels. You can prevent this by shifting the automatic transmission to **N** beforehand.

- Vehicles with DIRECT SELECT lever and KEYLESS-GO:

do not open the driver's door or front-passenger door when the engine is switched off. Otherwise, the automatic transmission selects park position **P** automatically and locks the wheels.

- ❗ If the key is within the rear detection range of KEYLESS-GO, the following situations, for example, could lead to the unintentional opening of the boot/tailgate:

- using a car wash
- using a high-pressure cleaner

Make sure that the key is at least 2 m away from the vehicle.

Observe the following to make sure that the automatic transmission on vehicles with DIRECT SELECT stays in position **N**:

- ▶ Make sure the vehicle is stationary and the ignition is switched off.
- ▶ Turn the key to position **2** (▷ page 177) in the ignition lock.
Use the key instead of the Start/Stop button on vehicles with KEYLESS-GO.
- ▶ Depress and hold the brake pedal.
- ▶ Shift the automatic transmission to position **N**.
- ▶ Release the brake pedal.
- ▶ Release the parking brake.
- ▶ Switch off the ignition and leave the key in the ignition lock.

You can wash the vehicle in an automatic car wash from the very start.

Wash off excess dirt before cleaning the vehicle in an automatic car wash.

After using an automatic car wash, wipe off wax from the windscreen and the wiper blades. This will prevent smears and reduce wiping noises caused by residue on the windscreen.

Washing by hand

In some countries, washing by hand is only allowed at specially equipped washing bays. Observe the legal requirements for each individual country.

- ▶ Do not use hot water and do not wash the vehicle in direct sunlight.
- ▶ Use a soft sponge to clean.
- ▶ Use a mild cleaning agent, such as a car shampoo approved by Mercedes-Benz.
- ▶ Thoroughly hose down the vehicle with a gentle jet of water.
- ▶ Do not point the water jet directly towards the air inlet.
- ▶ Use plenty of water and rinse out the sponge frequently.
- ▶ Rinse the vehicle with clean water and dry thoroughly with a chamois.
- ▶ Do not let the cleaning agent dry on the paintwork.

When using the vehicle in winter, remove all traces of road salt deposits carefully and as soon as possible.

High-pressure cleaning equipment

WARNING

The water jet of circular-jet nozzles (dirt grinders) can cause damage not visible from the outside to tyres or chassis components. Components damaged in this way can unexpectedly fail. There is a risk of an accident.

Do not use high-pressure cleaners with circular-jet nozzles to clean the vehicle. Have damaged tyres or chassis components replaced immediately.

- ❗ Always maintain a distance of at least 30 cm between the vehicle and the high-pressure cleaner nozzle. Information about the correct distance is available from the equipment manufacturer.

Move the high-pressure cleaner nozzle around when cleaning your vehicle.

Do not aim directly at any of the following:

- tyres
- door gaps, roof gaps, joints etc.
- electrical components
- battery
- connectors
- lights
- seals
- trim elements
- ventilation slots

Damaged seals or electrical components can lead to leaks or failures.

- ❗ If the key is within the rear detection range of KEYLESS-GO, the following situations, for example, could lead to the unintentional opening of the boot/tailgate:

- using a car wash
- using a high-pressure cleaner

Make sure that the key is at least 2 m away from the vehicle.

Cleaning the paintwork

! Do not affix:

- stickers
- films
- magnetic plates or similar items to painted surfaces. You could otherwise damage the paintwork.

Scratches, corrosive deposits, areas affected by corrosion and damage caused by inadequate care cannot always be completely repaired. In such cases, visit a qualified specialist workshop.

- ▶ Remove impurities immediately, where possible, whilst avoiding rubbing too hard.
- ▶ Soak insect remains with insect remover and rinse off the treated areas afterwards.
- ▶ Soak bird droppings with water and rinse off the treated areas afterwards.
- ▶ Remove coolant, brake fluid, tree resin, oils, fuels and greases by rubbing gently with a cloth soaked in petroleum ether or lighter fluid.
- ▶ Use tar remover to remove tar stains.
- ▶ Use silicone remover to remove wax.

Care and treatment of matt paintwork

! Never polish the vehicle or the light alloy wheels. Polishing makes the paintwork shiny.

! The following may cause the paint to become shiny and thus reduce the matt effect:

- Vigorous rubbing with unsuitable materials.
- Frequent use of car washes.
- Washing the vehicle in direct sunlight.

! Never use paint cleaner, buffing or polishing products, or gloss preserver, e.g. wax. These products are only suitable for high-gloss surfaces. Their use on vehicles with matt finish leads to considerable surface damage (shiny, spotted areas).

Always have paintwork repairs performed at a qualified specialist workshop, e.g. a Mercedes-Benz Service Centre.

! Do not use wash programs with a hot wax treatment under any circumstances.

Observe these notes if your vehicle has a clear matt finish. This will help you to avoid damage to the paintwork due to incorrect treatment.

These notes also apply to light-alloy wheels with a clear matt finish.

- i** The vehicle should preferably be washed by hand using a soft sponge, car shampoo and plenty of water.
- i** Use only insect remover and car shampoo from the range of recommended and approved Mercedes-Benz care products.

Cleaning vehicle parts

Cleaning the wheels

! Do not use acidic wheel cleaning products to remove brake dust. This could damage wheel bolts and brake components.

! Do not park up the vehicle for an extended period straight after cleaning it, particularly after having cleaned the wheels with wheel cleaner. Wheel cleaners could cause increased corrosion of the brake discs and brake pads/linings. For this reason, you should drive for a few minutes after cleaning. Braking heats the brake discs and the brake pads/linings, thus drying them. The vehicle can then be parked up.

Cleaning the windows

WARNING

If the windscreen wipers are set in motion when cleaning the windscreen or wiper blades, you could become trapped. There is a danger of injury.

Always switch off the windscreen wipers and the ignition before cleaning the windscreen or wiper blades.

- ❗ Do not use dry cloths, abrasive products, solvents or cleaning agents containing solvents to clean the inside of the windows. Do not touch the insides of the windows with hard objects, e.g. an ice scraper or ring. There is otherwise a risk of damaging the windows.
- ❗ Clean the water drainage channels of the windscreen and the rear window at regular intervals. Deposits such as leaves, petals and pollen may under certain circumstances prevent water from draining away. This can lead to corrosion damage and damage to electronic components.
- ▶ Clean the inside and outside of the windows with a damp cloth and a cleaning agent that is recommended and approved by Mercedes-Benz.

Cleaning the wiper blades

WARNING

If the windscreen wipers are set in motion when cleaning the windscreen or wiper blades, you could become trapped. There is a danger of injury.

Always switch off the windscreen wipers and the ignition before cleaning the windscreen or wiper blades.

- ❗ Do not pull on the wiper blade. Otherwise, the wiper blade could be damaged.
- ❗ Do not clean wiper blades too often and do not rub them too hard. Otherwise, the graphite coating could be damaged. This could cause wiper noise.
- ❗ Hold the wiper arm securely when folding back. The windscreen could be damaged if the wiper arm hits against it suddenly.

- ▶ Fold the wiper arms away from the windscreen.
- ▶ Clean the wiper blades carefully using a damp cloth.
- ▶ Fold the windscreen wipers back again before switching on the ignition.

Cleaning the exterior lighting

- ❗ Only use cleaning agents or cleaning cloths that are suitable for plastic lenses. Unsuitable cleaning agents or cleaning cloths could scratch or damage the plastic lenses of the exterior lighting.
- ▶ Clean the plastic lenses of the exterior lighting using a wet sponge and a mild cleaning agent, e.g. Mercedes-Benz car shampoo or cleaning cloths.

Mirror turn signals

- ❗ Only use cleaning agents or cleaning cloths that are suitable for plastic lenses. Unsuitable cleaning agents or cleaning cloths could scratch or damage the plastic lenses of the mirror turn signals.
- ▶ Clean the plastic lenses of the mirror turn signals in the exterior mirror housing using a wet sponge and mild cleaning agent, e.g. Mercedes-Benz car shampoo or cleaning cloths.

Cleaning the sensors

- ❗ If you clean the sensors with a high-pressure cleaner, make sure that you keep a distance of at least 30 cm between the vehicle and the high-pressure cleaner nozzle. Information about the correct distance is available from the equipment manufacturer.

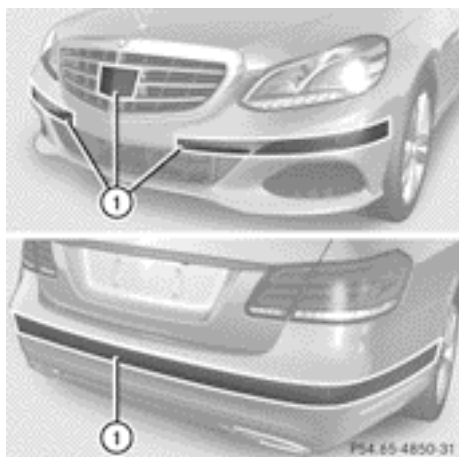

- ▶ Clean sensors ① of the driving systems with water, car shampoo and a soft cloth.

Cleaning the reversing camera

- ❗ Do not clean the camera lens and the area around the reversing camera with a high-pressure cleaner.

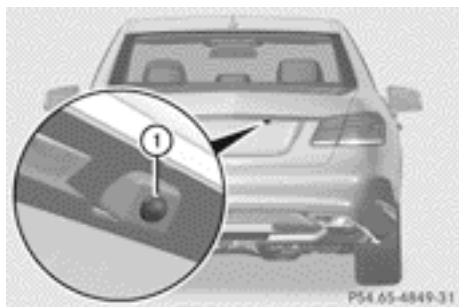

- ▶ Make sure that the vehicle is stationary and that the key is in position **2** in the ignition lock.
- ▶ **To open the cover of the reversing camera:** with COMAND Online activated, press the **sys** button.
- ▶ Select **Syst. settings** by turning **⏸** the COMAND controller and press **⏸** to confirm.
- ▶ Select **Rear view camera** and press **⏸** to confirm.

- ▶ Select **Open camera cover** and press **⏸** to confirm.
The cover of the 360° camera opens.
- ▶ **To clean the reversing camera:** use clear water and a soft cloth to clean camera lens ①.

Cleaning the 360° camera

- ❗ Do not clean the camera lens and the area around the 360° camera with a high-pressure cleaner.360

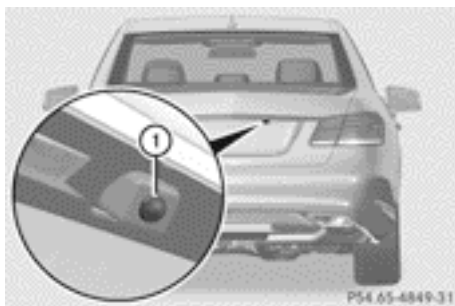

- ▶ Make sure that the vehicle is stationary and that the key is in position **2** in the ignition lock.
 - ▶ **To open the cover of the 360° camera:** with COMAND Online activated, press the **sys** button.
 - ▶ Select **Syst. settings** by turning **⏸** the COMAND controller and press **⏸** to confirm.
 - ▶ Select **360° camera** and press **⏸** to confirm.
 - ▶ Select **Open camera cover** and confirm with **⏸**.
The cover of the 360° camera opens.
 - ▶ **To clean the 360° camera:** clean camera lens ① with clear water and a soft cloth.
- i** If you drive at speeds above 30 km/h or with the key in position **0** or **1** in the ignition lock, the cover of the 360° camera closes automatically.

Cleaning the exhaust tail pipes

- ❗ Do not clean the exhaust pipe with acid-based cleaning agents such as sanitary cleansers or wheel cleaners.

Impurities combined with the effects of road grit and corrosive environmental factors may cause flash rust to form on the surface. You can restore the original shine of the exhaust pipe by cleaning it regularly, especially in winter and after washing.

- ▶ Clean the exhaust pipe with a care product tested and approved by Mercedes-Benz.

Cleaning the trailer tow hitch

🌿 Environmental note

Dispose of oily and greasy cloths in an environmentally-responsible manner.

- ❗ Do not clean the ball coupling with a high-pressure cleaner. Do not use solvents.
- ❗ Please note the care instructions in the trailer coupling manufacturer's operating instructions.



The ball coupling must be cleaned if it becomes dirty or corroded.

- ▶ Remove rust, e.g. with a wire brush.
- ▶ Remove dirt with a clean, lint-free cloth or a brush.
- ▶ After cleaning, lightly oil or grease ball coupling ①.
- ▶ Check that the vehicle's trailer tow hitch is working properly.

- ❗ You can also have the maintenance work on the ball coupling and the trailer tow hitch carried out by a qualified specialist workshop.

Interior care

Cleaning the display

- ❗ For cleaning, do not use any of the following:
 - alcohol-based thinner or petrol
 - abrasive cleaning agents
 - commercially-available household cleaning agents
 These may damage the display surface. Do not put pressure on the display surface when cleaning. This could lead to irreparable damage to the display.
- ▶ Before cleaning the display, make sure that it is switched off and has cooled down.
- ▶ Clean the display surface using a commercially available microfibre cloth and TFT/LCD display cleaner.
- ▶ Dry the display surface using a dry microfibre cloth.

Cleaning the plastic trim

⚠ WARNING

Care products and cleaning agents containing solvents can cause surfaces in the cockpit to become porous. This could result in plastic parts breaking away when the airbags are deployed. There is a danger of injury.

Do not use care products and cleaning agents containing solvents to clean the cockpit.

- ❗ Do not affix the following to plastic surfaces:
 - stickers
 - films
 - scented oil bottles or similar items
 You could otherwise damage the plastic.

! Do not allow cosmetics, insect repellent or sunscreen to come in contact with the plastic trim. This maintains the high-quality look of the surfaces.

- ▶ Wipe the plastic trim with a damp, lint-free cloth, e.g. a microfibre cloth.
- ▶ **Heavy soiling:** use car care and cleaning products recommended and approved by Mercedes-Benz.
The surface may change colour temporarily. Wait until the surface is dry again.

Cleaning the steering wheel and gear or selector lever

- ▶ Thoroughly wipe with a damp cloth or use leather care agents that have been recommended and approved by Mercedes-Benz.

Cleaning wooden trim and trim elements

! Do not use solvent-based cleaning agents such as tar remover, wheel cleaners, polishes or waxes. There is otherwise a risk of damaging the surface.

- ▶ Wipe the wooden trim and trim elements with a damp, lint-free cloth, e.g. a microfibre cloth.
- ▶ **Heavy soiling:** use car care and cleaning products recommended and approved by Mercedes-Benz.

Cleaning the seat covers

General notes

! Do not use microfibre cloths to clean genuine leather, artificial leather or Alcantara® covers. If used often, these can damage the cover.

- i** Note that regular care is essential to make sure that the appearance and comfort of the covers are retained over time.

Genuine leather seat covers

Leather is a natural product.

It has natural surface properties, e.g.:

- unevenness in structure
- marks caused by growth and injury
- subtle colour differences

These are characteristics of leather and not material faults.

! To retain the natural appearance of the leather, observe the following cleaning instructions:

- Clean genuine leather covers carefully with a damp cloth and then wipe the covers down with a dry cloth.
- Make sure that the leather does not become soaked. It may otherwise become rough and cracked.
- Only use leather care agents that have been tested and approved by Mercedes-Benz. You can obtain these from a qualified specialist workshop.

Seat covers from other materials

! Observe the following when cleaning:

- Clean artificial leather covers with a cloth moistened with a solution containing 1% detergent (e.g. washing-up liquid).
- Clean cloth covers with a microfibre cloth moistened with a solution containing 1% detergent (e.g. washing-up liquid). Rub carefully, and always wipe entire seat sections to avoid leaving visible lines. Leave the seat to dry afterwards. Cleaning results depend on the type of dirt and how long it has been there.
- Clean Alcantara® covers with a damp cloth. Make sure that you wipe entire seat sections to avoid leaving visible lines.

Cleaning the seat belts

WARNING

Seat belts may be severely weakened if bleached or coloured. This may lead to the

seat belts, for example, tearing or failing in an accident. There is an increased risk of injury, possibly even fatal.

Never bleach or colour seat belts.

- ❗ Do not clean the seat belts using chemical cleaning agents. Do not dry the seat belts at temperatures above 80 °C or in direct sunlight.
- ▶ Use clean, lukewarm water and soap solution.

Cleaning the roof lining and carpets

- ▶ **Roof lining:** if it is very dirty, use a soft brush or dry shampoo.
- ▶ **Carpets:** use the carpet and textile cleaning agents recommended and approved by Mercedes-Benz.

Useful information	382
Where will I find...?	382
Flat tyre	385
Battery (vehicle)	389
Jump-starting	393
Towing and tow-starting	396
Electrical fuses	399

Useful information

i This Owner's Manual describes all models, series and optional equipment for your vehicle that were available at the time of going to press. National variations are possible. Note that your vehicle may not be equipped with all of the functions described. This is also the case for systems and functions relevant to safety.

i Read the information on qualified specialist workshops: (▷ page 26).

- ▶ **Estate:** open the tailgate.
- ▶ Open the right-hand side trim panel.
- ▶ Remove warning triangle ①.

Setting up the warning triangle

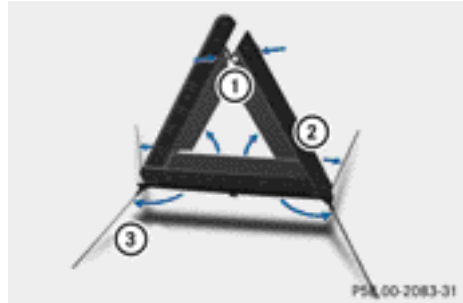

- ① Press-stud
- ② Reflectors
- ③ Feet

- ▶ Fold feet ③ down and out to the side.
- ▶ Fold side reflectors ② upwards to form a triangle and lock them at the top using press stud ①.

Where will I find...?

Warning triangle

Removing the warning triangle

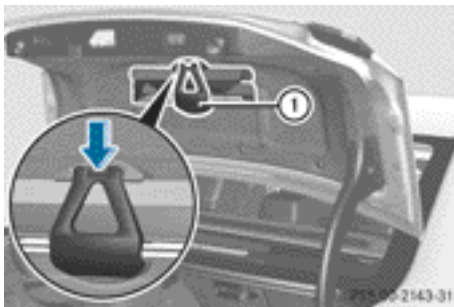

- ▶ **Saloon:** open the boot lid.
- ▶ Press warning triangle holder ① up in the direction of the arrow, open it and remove the warning triangle.

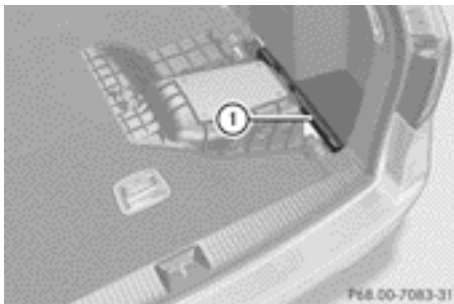

First-aid kit

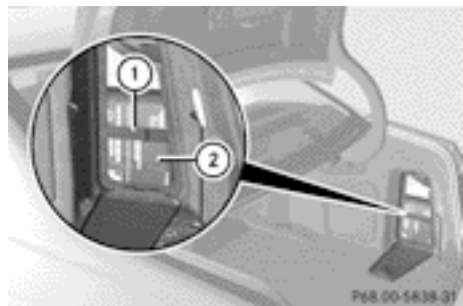

Saloon: the first-aid kit is in the right-hand stowage compartment in the boot.

- ▶ Open the boot lid.
- ▶ Slide the stowage net down.
- ▶ Open the stowage compartment.

- ▶ Remove tensioning strap ①.
- ▶ Remove first-aid kit ②.

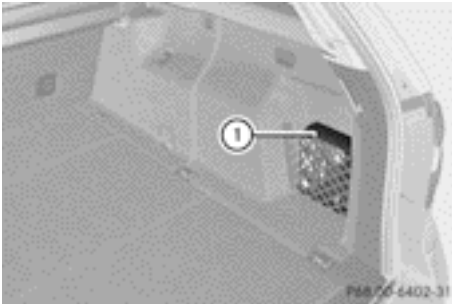

First-aid kit in the stowage net



First-aid kit behind the side trim panel

Estate: depending on the vehicle's equipment, the first-aid kit is in the stowage net or behind the side trim panel.

- ▶ Open the tailgate.
 - ▶ Open the right-hand side trim panel if the first-aid kit is in the side trim panel.
 - ▶ Remove first-aid kit ①.
- i** Check the expiry date on the first-aid kit at least once a year. Replace the contents if necessary, and replace any missing items.

Fire extinguisher

- !** Keep the stowage compartment closed while the vehicle is in motion. It may otherwise be damaged.

The fire extinguisher is located in the stowage compartment underneath the driver's seat.

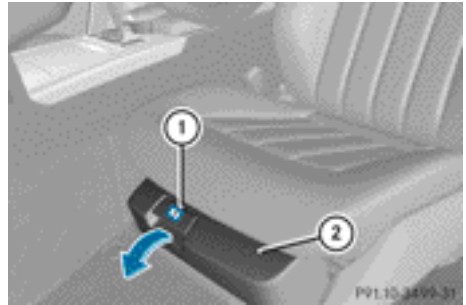

- ▶ Pull handle ① upward and fold cover ② forward.
 - ▶ Remove the fire extinguisher from the stowage compartment.
- i** Have the fire extinguisher refilled after each use and checked every one or two years. It may otherwise fail in an emergency.
- Observe the legal requirements for each individual country.

Vehicle tool kit

General notes

The vehicle tool kit can be found in the stowage well under the boot floor/luggage compartment floor. Depending on the vehicle equipment, the vehicle tool kit is on the left-hand side or the right-hand side in the stowage well under the boot floor/luggage compartment floor.

- i** Apart from some country-specific variants, vehicles are not equipped with tyre-changing tools. Some tools for changing a wheel are specific to the vehicle. For more information on which tools are required to perform a wheel change on your vehicle, consult a qualified specialist workshop.

Necessary tyre-changing tools can include, for example:

- Jack
- Wheel chock
- Wheel wrench

Vehicles with a TIREFIT kit

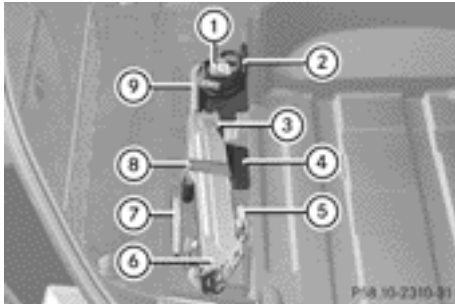

Example: vehicle tool kit in the left-hand stowage space

- ① Tyre sealant filler bottle
 - ② Folding wheel chock
 - ③ One pair of gloves (under jack)
 - ④ Tyre inflation compressor
 - ⑤ Towing eye
 - ⑥ Jack
 - ⑦ Centring pin
 - ⑧ Fuse allocation chart
 - ⑨ Wheel wrench
- ▶ Open the boot lid/tailgate.
 - ▶ Swing the boot/luggage compartment floor upwards (▷ page 345) or (▷ page 346).
 - ▶ Swing the boot floor (▷ page 345) or the luggage compartment floor (▷ page 346) upwards.

Vehicles with a spare wheel/"Minispare" emergency spare wheel

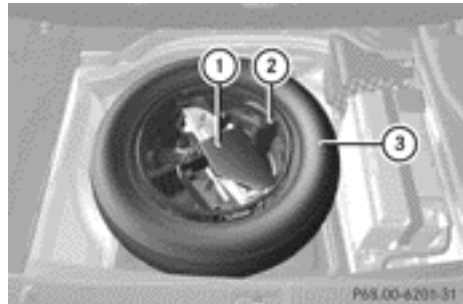

- ① Vehicle tool kit tray
- ② Stowage tray
- ③ Spare wheel/"Minispare" emergency spare wheel

- ▶ Open the boot lid/tailgate.
- ▶ Swing the boot/luggage compartment floor upwards (▷ page 345) or (▷ page 346).
- ▶ Swing the boot floor (▷ page 345) or the luggage compartment floor (▷ page 346) upwards.

The vehicle tool kit contains:

- Foldable wheel chock
- Fuse allocation chart
- Jack
- Centring pin
- One pair of gloves
- Wheel wrench
- Towing eye

Vehicles with a collapsible emergency spare wheel

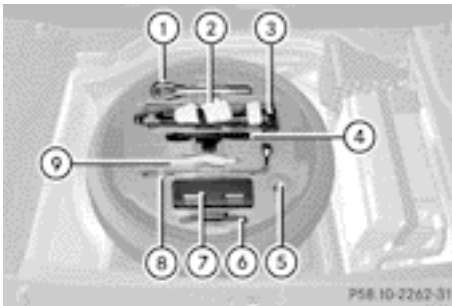

- ① Towing eye
- ② One pair of gloves
- ③ Jack
- ④ Folding wheel chock
- ⑤ Centring pin
- ⑥ Sheet for faulty wheel
- ⑦ Tyre inflation compressor
- ⑧ Wheel wrench
- ⑨ Fuse allocation chart

- ▶ Open the boot lid/tailgate.
- ▶ Swing the boot/luggage compartment floor upwards (▷ page 345) or (▷ page 346).
- ▶ Swing the boot floor (▷ page 345) or the luggage compartment floor (▷ page 346) upwards.

Flat tyre

Preparing the vehicle

Your vehicle may be equipped with:

- MOExtended tyres (tyres with run-flat characteristics) (▷ page 385)
Vehicle preparation is not necessary on vehicles with MOExtended tyres.
- a TIREFIT kit (▷ page 383)
- an emergency spare wheel (only for certain countries) (▷ page 459)

Information on changing/fitting a wheel (▷ page 413).

- ▶ Stop the vehicle as far away as possible from traffic on solid, non-slippery and level ground.
- ▶ Switch on the hazard warning lamps.
- ▶ Secure the vehicle against rolling away (▷ page 199).
- ▶ If possible, bring the front wheels into the straight-ahead position.
- ▶ Vehicles with AIRMATIC: make sure that "normal" level is selected (▷ page 224).
- ▶ Switch off the engine.
- ▶ **Vehicles without KEYLESS-GO:** remove the key from the ignition lock.
- ▶ **Vehicles with KEYLESS-GO:** open the driver's door.
The on-board electronics now have status **0**. This is the same as the key having been removed.
- ▶ **Vehicles with KEYLESS-GO:** remove the Start/Stop button from the ignition lock (▷ page 177).
- ▶ All occupants must get out of the vehicle. Make sure that they are not endangered as they do so.
- ▶ Make sure that no one is near the danger area while a wheel is being changed. Anyone who is not directly assisting in the wheel change should, for example, stand behind the barrier.
- ▶ Get out of the vehicle. Pay attention to traffic conditions when doing so.
- ▶ Close the driver's door.
- ▶ Place the warning triangle a suitable distance away (▷ page 382). Observe legal requirements.

MOExtended tyres (tyres with run-flat characteristics)

General notes

With MOExtended tyres (tyres with run-flat characteristics), you can continue to drive your vehicle even if there is a total loss of pressure in one or more tyres. The affected

tyre must not show any clearly visible damage.

You can recognise MOExtended tyres by the MOExtended marking which appears on the tyre wall. You will find this marking next to the tyre size designation, the load-bearing capacity and the speed index.

MOExtended tyres may only be used in conjunction with an active tyre pressure loss warning system.

If the pressure loss warning message appears in the multifunction display:

- observe the instructions in the display messages (▷ page 312)
- check the tyre for damage
- if driving on, observe the following notes

The maximum driving distance is approximately 80 km when the vehicle is partially laden and approximately 30 km when the vehicle is fully laden.

In addition to the vehicle load, the driving distance possible depends upon:

- speed
- road condition
- outside temperature

The driving distance possible in run-flat mode may be reduced by extreme driving conditions/manoeuvres, or it can be increased through a moderate style of driving.

The maximum permissible distance which can be driven in run-flat mode is counted from the moment the tyre pressure loss warning appears in the multifunction display.

You must not exceed a maximum speed of 80 km/h.

- i** When replacing one or all tyres, make sure that you use only:
 - the tyre size specified for the vehicle and
 - tyre(s) marked "MOExtended"

If a tyre has gone flat and cannot be replaced with an MOExtended tyre, a standard tyre may be used as a temporary measure. Make sure that you use the

proper size and type (summer or winter tyre).

- i** Vehicles with MOExtended tyres are not equipped with a TIREFIT kit at the factory. It is therefore recommended that you additionally equip your vehicle with a TIREFIT kit if you fit tyres that do not feature run-flat characteristics, e.g. winter tyres. A TIREFIT kit can be obtained from a qualified specialist workshop.

Important safety notes

⚠ WARNING

When driving in emergency mode, the driving characteristics deteriorate, e.g. when cornering, accelerating quickly and when braking. There is a risk of accident.

Do not exceed the stated maximum speed. Avoid abrupt steering and driving manoeuvres, and driving over obstacles (kerbs, pot-holes, off-road). This applies in particular to a laden vehicle.

Stop driving in emergency mode if:

- you hear banging noises.
- the vehicle starts to shake.
- you see smoke and smell rubber.
- ESP® is intervening constantly.
- there are tears in the sidewalls of the tyre.

After driving in emergency mode, have the wheel rims checked at a qualified specialist workshop with regard to their further use. The faulty tyre must be replaced.

TIREFIT kit

Using the TIREFIT kit

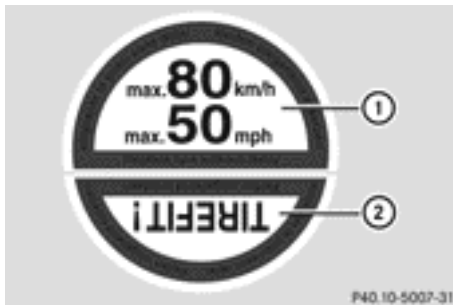

TIREFIT sticker, 2-part

- ▶ Do not remove any foreign objects which have penetrated the tyre, e.g. screws or nails.
- ▶ Remove the tyre sealant bottle, the accompanying TIREFIT sticker and the tyre inflation compressor from the stowage space under the boot floor/luggage compartment floor (▷ page 383).
- ▶ Affix part ① of the TIREFIT sticker within the driver's field of vision.
- ▶ Affix part ② of the TIREFIT sticker near the valve on the wheel with the defective tyre.

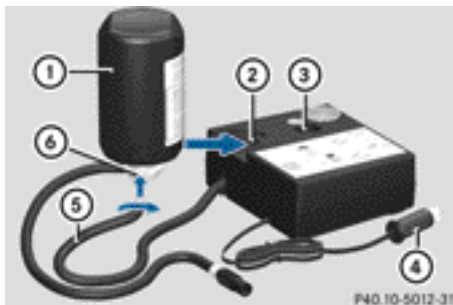

- ▶ Pull plug ④ with the cable and hose ⑤ out of the housing.
- ▶ Screw hose ⑤ onto flange ⑥ of tyre sealant bottle ①.
- ▶ Place tyre sealant bottle ① head downwards into recess ② of the tyre inflation compressor.

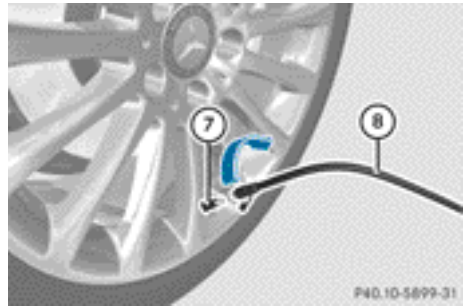

- ▶ Remove the cap from valve ⑦ on the faulty tyre.
- ▶ Screw filler hose ⑧ onto valve ⑦.
- ▶ Insert plug ④ into a 12 V socket (▷ page 353) in your vehicle. Observe the notes on sockets (▷ page 353).
- ▶ Turn the key to position 1 in the ignition lock (▷ page 177).
- ▶ Press on/off switch ③ on the tyre inflation compressor to I. The tyre inflation compressor is switched on. The tyre is inflated.

i First, tyre sealant is pumped into the tyre. The pressure may briefly rise to approximately 500 kPa (5 bar/73 psi).

Do not switch off the tyre inflation compressor during this phase.

- ▶ Let the tyre inflation compressor run for five minutes. The tyre should then have attained a pressure of at least 180 kPa (1.8 bar/26 psi).

If a pressure of 180 kPa (1.8 bar/26 psi) has been attained after five minutes, see "Tyre pressure reached" (▷ page 388).

If a tyre pressure of 180 kPa (1.8 bar/26 psi) has not been attained after five minutes, see "Tyre pressure not reached" (▷ page 388).

i If the tyre sealant leaks out, allow it to dry. It can then be removed like a layer of film.

If you get tyre sealant on your clothing, have it cleaned as soon as possible with perchloroethylene.

Tyre pressure not reached

If a pressure of 180 kPa (1.8 bar/26 psi) has not been achieved after five minutes:

- ▶ Switch off the tyre inflation compressor.
 - ▶ Unscrew the filler hose from the valve of the faulty tyre.
 - ▶ Very slowly drive forwards or reverse approximately 10 m.
 - ▶ Pump up the tyre again.
- After a maximum of five minutes the tyre pressure must be at least 180 kPa (1.8 bar/26 psi).

WARNING

If the required tyre pressure is not reached after the specified time, the tyre is too badly damaged. The tyre sealant cannot repair the tyre in this instance. Damaged tyres and a tyre pressure that is too low can significantly impair the vehicle's braking and driving characteristics. There is a risk of accident.

Do not continue driving. Contact a qualified specialist workshop.

Tyre pressure reached

WARNING

A tyre temporarily sealed with tyre sealant impairs the driving characteristics and is not suitable for higher speeds. There is a risk of accident.

You should therefore adapt your driving style accordingly and drive carefully. Do not exceed the specified maximum speed with a tyre that has been repaired using tyre sealant.

- ❗ After use, excess tyre sealant may run out of the filler hose. This could cause stains. Therefore, place the filler hose in the plastic bag which contained the TIREFIT kit.

Environmental note

Have the used tyre sealant bottle disposed of professionally, e.g. at a qualified specialist workshop.

If a tyre pressure of 180 kPa (1.8 bar/26 psi) has been attained after five minutes:

- ▶ Switch off the tyre inflation compressor.
- ▶ Unscrew the filler hose from the valve of the faulty tyre.
- ▶ Stow the tyre sealant bottle, the tyre inflation compressor and the warning triangle.
- ▶ **Pull away immediately.**

The maximum speed for a tyre sealed with tyre sealant is 80 km/h. The upper part of the TIREFIT sticker must be affixed to the instrument cluster where it will be easily seen by the driver.

- ▶ Stop after driving for approximately ten minutes and check the tyre pressure with the tyre inflation compressor. The tyre pressure must now be at least 130 kPa (1.3 bar/19 psi).

WARNING

If the required tyre pressure is not reached after driving for a short period, the tyre is too badly damaged. The tyre sealant cannot repair the tyre in this instance. Damaged tyres and a tyre pressure that is too low can significantly impair the vehicle's braking and driving characteristics. There is a risk of accident.

Do not continue driving. Contact a qualified specialist workshop.

- ▶ Correct the tyre pressure if it is still at least 130 kPa (1.3 bar/19 psi) (see the fuel filler flap for values).
- ▶ **To increase the tyre pressure:** switch on the tyre inflation compressor.

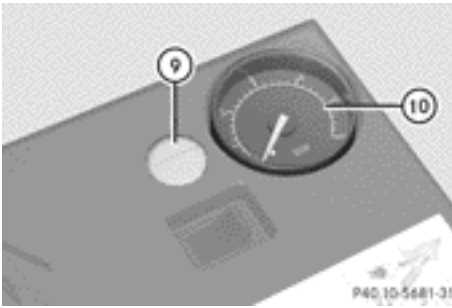

- ▶ **To reduce the tyre pressure:** depress pressure release button ⑨ next to pressure gauge ⑩.
 - ▶ When the tyre pressure is correct, unscrew the filler hose from the valve of the sealed tyre.
 - ▶ Screw the valve cap onto the tyre valve of the sealed tyre.
 - ▶ Pull the tyre sealant bottle out of the tyre inflation compressor.
The filler hose stays on the tyre sealant bottle.
 - ▶ Stow the tyre sealant bottle, the tyre inflation compressor and the warning triangle.
 - ▶ Drive to the nearest qualified specialist workshop and have the tyre changed there.
 - ▶ Have the tyre sealant bottle replaced as soon as possible at a qualified specialist workshop.
 - ▶ Have the tyre sealant bottle replaced every four years at a qualified specialist workshop.
- i** In your vehicle, you will find a sticker with the Mercedes-Benz Service24h telephone number, e.g. on the B-pillar on the driver's side.

Battery (vehicle)

Important safety notes

Work on the battery, e.g. removing or fitting, requires specialist knowledge and the use of special tools. Therefore, always have work on

the battery carried out at a qualified specialist workshop.

WARNING

Work carried out incorrectly on the battery may lead to a malfunction, e.g. a short circuit. This, in turn, may restrict the functions of the safety-relevant systems, e.g. the lighting system, ABS (Anti-lock Braking System) or ESP® (Electronic Stability Program). The operating safety of your vehicle may then be compromised. You could then lose control of the vehicle, e.g.:

- when braking
- when making sudden steering movements and/or travelling at an inappropriate speed.

There is a risk of an accident.

In the event of a short circuit or similar situation, inform a qualified specialist workshop immediately. Do not drive any further. You should have all work involving the battery carried out at a qualified specialist workshop.

For further information about ABS and ESP®, see (▷ page 72) and (▷ page 77).

WARNING

Electrostatic build-up can lead to the creation of sparks, which could ignite the highly explosive gases of a battery. There is a risk of an explosion.

Before handling the battery, touch the vehicle body to remove any existing electrostatic build-up.

The highly flammable gas mixture is created while the battery is charging and when jump-starting.

Always make sure that neither you nor the battery is electrostatically charged. Electrostatic charge is created, for example:

- by wearing synthetic fibre clothing
- due to friction between clothing and the seat

- when you pull or push the battery across carpet or other synthetic materials
- when you rub the battery with a cloth

WARNING

During the charging process, a battery produces hydrogen gas. If a short circuit occurs or sparks are created, the hydrogen gas can ignite. There is a risk of an explosion.

- Make sure that the positive terminal of a connected battery does not come into contact with vehicle parts.
- Never place metal objects or tools on a battery.
- It is important that you observe the described order of the battery terminals when connecting and disconnecting a battery.
- When jump-starting, make sure that the battery poles with identical polarity are connected.
- It is particularly important to observe the described order when connecting and disconnecting the jump leads.
- Never connect or disconnect the battery terminals while the engine is running.

WARNING

Battery acid is caustic. There is a risk of injury. Avoid contact with the skin, eyes or clothing. Do not inhale any battery gases. Do not lean over the battery. Keep children away from batteries. Wash battery acid immediately with water and seek medical attention.

Environmental note



Batteries contain pollutants. It is illegal to dispose of them with the household rubbish. They must be collected separately and disposed of in an environmentally responsible recycling system.



Dispose of batteries in an environmentally responsible manner. Take discharged batteries to a qualified spe-

cialist workshop or to a collection point for used batteries.

- ❗ Have the battery checked regularly at a qualified specialist workshop. Observe the service intervals in the Service Booklet or contact a qualified specialist workshop for more information.

- ❗ You should have all work involving the battery carried out at a qualified specialist workshop. In the exceptional case that it is necessary for you to disconnect the battery yourself, make sure that:

- you switch off the engine and remove the key. On vehicles with KEYLESS-GO, ensure that the ignition is switched off. Check that all the indicator lamps in the instrument cluster are off. Otherwise, electronic components, such as the alternator, may be damaged.
- you first remove the negative terminal clamp and then the positive terminal clamp. Never swap the terminal clamps. Otherwise, the vehicle's electronic system may be damaged.
- in vehicles with automatic transmission, the transmission is locked in position **P** after disconnecting the battery. The vehicle is secured against rolling away. You can then no longer move the vehicle.

The battery and the cover of the positive terminal clamp must be fitted securely during operation.

Comply with safety precautions and take protective measures when handling batteries.



WARNING



Fire, naked flames and smoking are prohibited when handling the battery. Avoid creating sparks.



Battery acid is caustic. Avoid contact with the skin, eyes or clothing.

Wear suitable protective clothing, in particular gloves, an apron and a face mask.

Immediately rinse acid splashes off with clean water. Consult a doctor if necessary.



Wear eye protection.



Keep children away.



Observe this Owner's Manual.

HYBRID vehicles: make sure that you read the "HYBRID" supplement included in the vehicle literature. You could otherwise fail to recognise dangers, e.g. due to high voltage.

For safety reasons, Mercedes-Benz recommends that you only use batteries which have been tested and approved for your vehicle by Mercedes-Benz. These batteries provide increased impact protection to prevent vehicle occupants from suffering acid burns should the battery be damaged in the event of an accident.

In order for the battery to achieve the maximum possible service life, it must always be sufficiently charged.

The vehicle battery, like other batteries, can discharge over time if you do not use the vehicle. In such cases, have the battery disconnected at a qualified specialist workshop. You can also charge the battery with a charger recommended by Mercedes-Benz. For more information, please contact a qualified specialist workshop.

Have the battery charge checked more frequently if you use the vehicle mainly for short trips or if you leave it standing idle for a lengthy period. Consult a qualified specialist

workshop if you wish to leave your vehicle parked up for a long period of time.

i When you park the vehicle, remove the key if you do not require any electrical consumers. The vehicle will then use very little energy, thus conserving battery power.

i If the power supply has been interrupted, e.g. if the battery was discharged, you will have to:

- set the clock. Information on setting the clock can be found in the separate operating instructions.

On vehicles with COMAND Online and a navigation system, the clock is set automatically.

- reset the function for folding the exterior mirrors in/out automatically, by folding the mirrors out once (> page 130).

Charging the battery

WARNING

During charging and jump-starting, explosive gases can escape from the battery. There is a risk of an explosion.

Particularly avoid fire, naked flames, creating sparks and smoking. Ensure there is sufficient ventilation while charging and jump-starting. Do not lean over a battery.

WARNING

Battery acid is caustic. There is a risk of injury. Avoid contact with the skin, eyes or clothing. Do not inhale any battery gases. Do not lean over the battery. Keep children away from batteries. Wash battery acid immediately with water and seek medical attention.

WARNING

A discharged battery can freeze at temperatures below freezing point. When jump-starting the vehicle or charging the battery, gases can escape from the battery. There is a risk of an explosion.

Allow the frozen battery to thaw out before charging it or jump-starting.

! Only use battery chargers with a maximum charging voltage of 14.8 V.

! Only charge the battery using the jump-start connection point.

The jump-starting connection point is in the engine compartment (> page 393).

- ▶ Open the bonnet.
- ▶ Connect the battery charger to the positive terminal and earth point in the same order as when connecting the donor battery in the jump-starting procedure (> page 393).

If the indicator/warning lamps do not light up at low temperatures, it is very likely that the discharged battery has frozen. In this case, you may neither charge the battery nor jump-start the vehicle. The service life of a battery that has been thawed may be reduced. The starting characteristics may be impaired, especially at low temperatures. Have the thawed battery checked at a qualified specialist workshop.

Never charge a battery still installed in the vehicle unless a battery charger unit approved by Mercedes-Benz is being used. A battery charger unit specially adapted for Mercedes-Benz vehicles and tested and approved by Mercedes-Benz is available as an accessory. It permits the charging of the battery in its installed position. Contact a Mercedes-Benz Service Centre for information and availability. Read the battery charger's operating instructions before charging the battery.

Jump-starting

For the jump-starting procedure, use only the jump-starting connection point, consisting of a positive terminal and an earth point, in the engine compartment.

WARNING

Battery acid is caustic. There is a risk of injury.

Avoid contact with the skin, eyes or clothing. Do not inhale any battery gases. Do not lean over the battery. Keep children away from batteries. Wash battery acid immediately with water and seek medical attention.

WARNING

During charging and jump-starting, explosive gases can escape from the battery. There is a risk of an explosion.

Particularly avoid fire, naked flames, creating sparks and smoking. Ensure there is sufficient ventilation while charging and jump-starting. Do not lean over a battery.

WARNING

During the charging process, a battery produces hydrogen gas. If a short circuit occurs or sparks are created, the hydrogen gas can ignite. There is a risk of an explosion.

- Make sure that the positive terminal of a connected battery does not come into contact with vehicle parts.
- Never place metal objects or tools on a battery.
- It is important that you observe the described order of the battery terminals when connecting and disconnecting a battery.
- When jump-starting, make sure that the battery poles with identical polarity are connected.
- It is particularly important to observe the described order when connecting and disconnecting the jump leads.
- Never connect or disconnect the battery terminals while the engine is running.

WARNING

A discharged battery can freeze at temperatures below freezing point. When jump-starting the vehicle or charging the battery, gases can escape from the battery. There is a risk of an explosion.

Allow the frozen battery to thaw out before charging it or jump-starting.

⚠ Vehicles with a petrol engine: avoid repeated and lengthy starting attempts. Otherwise, the non-combusted fuel may damage the catalytic converter.

HYBRID vehicles: make sure that you read the "HYBRID" supplement included in the vehicle literature. You could otherwise fail to recognise dangers, e.g. due to high voltage.

Do not use a rapid charging device to start the vehicle. If your vehicle's battery is discharged, the engine can be jump-started from another vehicle or from a second battery using jump leads. Observe the following points:

- The battery is not accessible in all vehicles. If the other vehicle's battery is not accessible, jump-start the vehicle using a second battery or a jump-starting device.
- **Vehicles with a petrol engine:** only jump-start the vehicle when the engine and exhaust system are cold.
- Do not start the engine if the battery is frozen. Let the battery thaw first.
- Jump-starting may only be performed from batteries with a nominal voltage of 12 V.
- Only use jump leads that have a sufficient cross-section and insulated terminal clamps.
- If the battery is fully discharged, leave the battery that is being used to jump-start connected for a few minutes before attempting to start. This charges the empty battery a little.
- Make sure that the two vehicles do not touch.

Make sure that:

- the jump leads are not damaged.
- non-insulated parts of the terminal clamps do not come into contact with other metal parts while the jump leads are connected to the battery.
- the jump leads cannot come into contact with parts which can move when the engine is running, such as the V-belt pulley or the fan.
- ▶ Firmly depress the parking brake.
- ▶ **Manual transmission:** depress the clutch pedal fully and shift to neutral.
- ▶ **Automatic transmission:** shift the transmission to position **P**.
- ▶ Switch off all electrical consumers, e.g. rear window heating, lighting etc.
- ▶ Open the bonnet.

Position number ⑥ identifies the charged battery of the other vehicle or an equivalent jump-starting device.

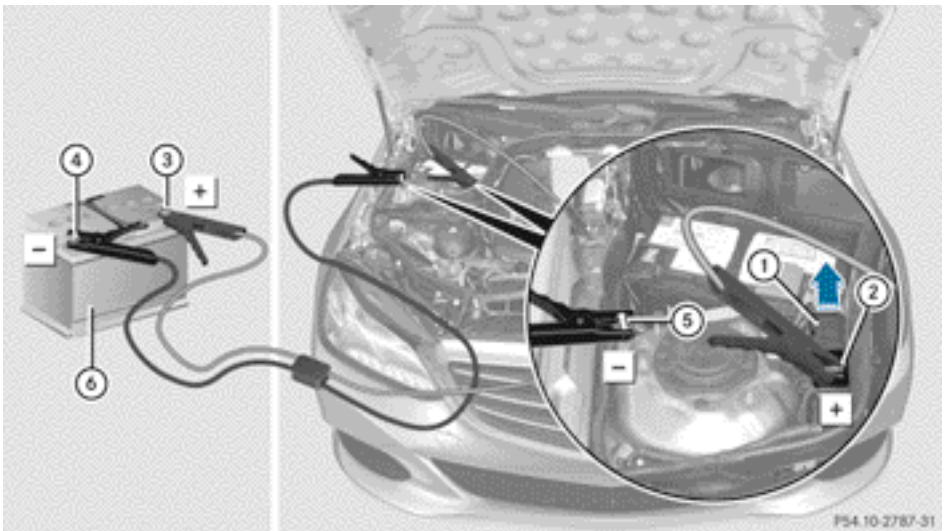

P54.10-2787-31

- ▶ Slide cover ① of positive terminal ② in the direction of the arrow.
 - ▶ Connect positive terminal ② on your vehicle to positive terminal ③ of donor battery ⑥ using the jump lead. Always begin with positive terminal ② on your own vehicle first.
 - ▶ Start the engine of the donor vehicle and run it at idling speed.
 - ▶ Connect negative terminal ④ of donor battery ⑥ to earth point ⑤ of your vehicle using the jump lead, connecting the jump lead to donor battery ⑥ first.
 - ▶ Start the engine.
 - ▶ Before disconnecting the jump leads, let the engines run for several minutes.
 - ▶ First, remove the jump leads from earth point ⑤ and negative terminal ④, then from positive clamp ② and positive terminal ③. Begin each time at the contacts on your own vehicle first.
 - ▶ Close cover ① of positive clamp ② after removing the jump leads.
 - ▶ Have the battery checked at a qualified specialist workshop.
- i** Jump-starting is not considered to be a normal operating condition.
i Jump-starting cables and further information regarding jump starting can be obtained at any qualified specialist workshop.

Towing and tow-starting

Important safety notes

WARNING

Safety-relevant functions are restricted or not available if:

- the engine is not running.
- the brake system or the power steering is malfunctioning
- the voltage supply or the vehicle's electrical system is malfunctioning.

If your vehicle is towed, significantly greater force may be required to steer the vehicle or to brake. There is a risk of an accident.

In such circumstances, use a towing bar. Make sure that the steering is moving freely before towing.

WARNING

If the weight of the vehicle to be towed or tow-started is greater than the permissible gross weight of your vehicle:

- the towing eye could detach itself
- the vehicle/trailer combination could overturn.

There is a risk of an accident.

When towing or tow-starting another vehicle, its weight should not be greater than the permissible gross weight of your vehicle.





Information on your vehicle's gross vehicle weight rating can be found on the vehicle identification plate (▷ page 468).

-  If DISTRONIC PLUS or the HOLD function is activated, the vehicle brakes automatically in certain situations. To prevent damage to the vehicle, deactivate DISTRONIC PLUS and the HOLD function in the following or other similar situations:

- when towing the vehicle
- in the car wash

-  Only secure the tow cable or tow bar to the towing eyes or, if available, to the trailer

tow hitch. You could otherwise damage the vehicle.

-  Observe the following points when towing with a tow rope:
 - Secure the tow rope on the same side on both vehicles.
 - Make sure that the tow rope is not longer than legally permitted. Mark the tow rope in the middle, e.g. with a white cloth (30 x 30 cm). This will make other road users aware that a vehicle is being towed.
 - Only secure the tow cable to the towing eyes or, if available, to the trailer tow hitch.
 - Observe the brake lamps of the towing vehicle while driving. Always maintain a distance a distance so that the tow rope does not sag.
 - Do not use steel cables or chains to tow your vehicle. You could otherwise damage the vehicle.
 -  Do not use the towing eye for recovery, this could damage the vehicle. If in doubt, recover the vehicle with a crane.
 -  Pull away smoothly when towing away or tow-starting a vehicle. If the tractive power is too high, the vehicles could be damaged.
 -  To tow vehicles with KEYLESS-GO, use the key instead of the Start/Stop button. The automatic transmission may otherwise switch to position **P** when you open the driver's or front-passenger door which could damage the transmission.
 -  You may tow the vehicle for a maximum of 50km. A towing speed of 50 km/h must not be exceeded.

For towing distances over 50 km, the entire vehicle must be lifted up and transported.
- HYBRID vehicles:** make sure that you read the "HYBRID" supplement included in the vehicle literature. You could otherwise fail to recognise dangers, e.g. due to high voltage.

Observe the legal requirements for the relevant countries when towing and tow-starting. It is better to have the vehicle transported than to have it towed.

If the vehicle has suffered transmission damage, have it transported on a transporter or trailer.

When towing a vehicle with an automatic transmission, the transmission must be in position **N**.

The battery must be connected and charged. Otherwise, you:

- cannot turn the key in the ignition lock to position **2**
- cannot shift the transmission to position **N** on vehicles with automatic transmission

i Deactivate the automatic locking feature before the vehicle is towed (▷ page 96). You could otherwise be locked out when pushing or towing the vehicle.

Deactivate tow-away protection before the vehicle is towed away (▷ page 84).

Fitting/removing the towing eye

Fitting the towing eye

WARNING

The exhaust tail pipe may be extremely hot. There is a risk of burning when removing the rear cover.

Do not touch the exhaust tail pipe. Use extreme caution when removing the rear cover.

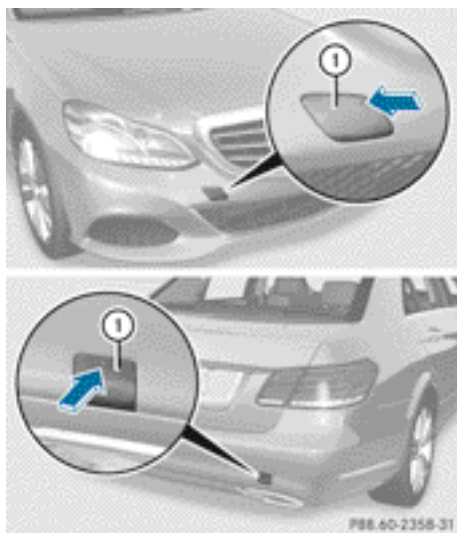

Towing eye covers (example: Saloon)

Vehicles with a trailer tow hitch: if you intend to use the vehicle for towing, fold out the ball coupling and connect the towbar to it (▷ page 261).

The brackets for the screw-in towing eyes are located in the bumpers. They are under the covers at the front and at the rear on vehicles without a trailer coupling. On vehicles with a trailer coupling, the bracket is at the front under the cover.

- ▶ Remove the towing eye from the vehicle tool kit (▷ page 383).
- ▶ Press the mark on cover ① inwards in the direction of the arrow.
- ▶ Remove cover ① from the opening.
- ▶ Screw the towing eye in clockwise to the stop and tighten it.

Removing the towing eye

- ▶ Loosen the towing eye and unscrew it.
- ▶ Attach cover ① to the bumper and press until it engages.
- ▶ Place the towing eye in the vehicle tool kit.

Towing the vehicle with the rear axle raised

! The ignition must be switched off if you are towing the vehicle with the rear axle raised. Intervention by ESP® could otherwise damage the brake system.

Only possible on vehicles without 4MATIC.

- ▶ Switch on the hazard warning lamps (▷ page 140).
- ▶ Turn the key in the ignition lock to position **0** and remove the key from the ignition lock.
- ▶ When leaving the vehicle, take the key or the KEYLESS-GO key with you.

When towing your vehicle with the rear axle raised, it is important that you observe the safety instructions (▷ page 396).

Towing the vehicle with both axles on the ground

It is important that you observe the safety instructions when towing away your vehicle (▷ page 396).

The automatic transmission automatically shifts to position **P** when you open the driver's or front-passenger door or when you remove the key from the ignition lock. In order to ensure that the automatic transmission stays in position **N** when towing the vehicle, you must observe the following points:

- ▶ Make sure that the vehicle is stationary and that the key is in position **0** in the ignition lock.
- ▶ Turn the key to position **2** in the ignition lock.
On vehicles with KEYLESS-GO, use the key instead of the Start/Stop button (▷ page 177).
- ▶ Depress and hold the brake pedal.
- ▶ Shift the automatic transmission to position **N**.

▶ **Vehicles with manual transmission:** depress the clutch pedal fully and shift to neutral.

- ▶ Release the brake pedal.
- ▶ Release the parking brake.
- ▶ Switch on the hazard warning lamps (▷ page 140).
- ▶ Leave the key in position **2** in the ignition lock.

i When towing with the hazard warning lamps switched on, use the combination switch as usual to signal a change of direction. In this case, only the turn signals for the desired direction flash. When you reset the combination switch, the hazard warning lamps start flashing again.

Transporting the vehicle

! You may only secure the vehicle by the wheels, not by parts of the vehicle such as axle or steering components. Otherwise, the vehicle could be damaged.

The towing eyes or trailer tow hitch can be used to pull the vehicle onto a trailer or transporter if you wish to transport it.

- ▶ **Vehicles with manual transmission:** depress the clutch pedal fully and shift to neutral.
- ▶ **Vehicles with automatic transmission:** turn the key to position **2** in the ignition lock.
- ▶ Shift the automatic transmission to position **N**.

As soon as the vehicle is loaded:

- ▶ Prevent the vehicle from rolling away by applying the parking brake.
- ▶ **Vehicles with manual transmission:** depress the clutch pedal fully and engage first or reverse gear.
- ▶ **Vehicles with automatic transmission:** shift the automatic transmission to position **P**.

- ▶ Turn the key in the ignition lock to position **0** and remove the key from the ignition lock.
- ▶ Secure the vehicle.

Notes for 4MATIC vehicles

! Vehicles with 4MATIC must not be towed with the front or rear axle raised; otherwise, the transmission may be damaged.

If the vehicle has transmission damage or damage to the front or rear axle, have it transported on a transporter or trailer.

In the event of damage to the electrical system

If the battery is defective, the automatic transmission will be locked in position **P**. To shift the automatic transmission to position **N**, you must provide power to the vehicle's electrical system in the same way as when jump-starting (▷ page 393).

Have the vehicle transported on a transporter or trailer.

Tow-starting (emergency engine starting)

! Vehicles with automatic transmission must not be tow-started. The transmission may otherwise be damaged.

You can find information on "Jump-starting" under (▷ page 393).

Before tow-starting the following conditions must be fulfilled:

- the battery is connected.
- the engine has cooled down.
- the exhaust system has cooled down.

When tow-starting, it is important that you observe the safety notes (▷ page 396) and the legal requirements in each respective country.

- ▶ Switch on the hazard warning lamps (▷ page 140).
- ▶ Fit the towing eye (▷ page 397).
- ▶ Secure the rigid towing bar or the towing rope.
- ▶ Depress and hold the brake pedal.
- ▶ Turn the key to position **2** in the ignition lock.
- ▶ Depress the clutch pedal fully, engage second gear and continue to keep the clutch pedal fully depressed.
- ▶ Release the brake pedal.
- ▶ Tow-start the vehicle.
- ▶ Release the clutch pedal slowly, do not depress the accelerator pedal while doing so.
- ▶ When the engine has been started, immediately depress the clutch pedal fully and shift to neutral.
- ▶ Stop at a suitable place according to the traffic conditions.
- ▶ Depress the parking brake.
- ▶ Remove the rigid towing bar or towing rope.
- ▶ Remove the towing eye (▷ page 397).
- ▶ Switch off the hazard warning lamps.

Electrical fuses

Important safety notes

WARNING

If you manipulate, bridge or replace a faulty fuse with a fuse of a higher amperage, the electric cables could be overloaded. This may result in a fire. There is a risk of an accident and injury.

Always replace faulty fuses with specified new fuses of the correct amperage.

- !** Only use fuses that have been approved for Mercedes-Benz vehicles and which have the correct fuse rating for the system concerned. Otherwise, components or systems could be damaged.

The fuses in your vehicle serve to disconnect faulty circuits. If a fuse blows, all the components on the circuit and their functions will fail.

Blown fuses must be replaced with fuses of the same rating, which you can recognise by the colour and fuse rating. The fuse ratings are listed in the fuse allocation chart.

If the newly inserted fuse also blows, have the cause traced and rectified at a qualified specialist workshop, e.g. a Mercedes-Benz Service Centre.

Before replacing a fuse

Observe the important safety notes
(▷ page 399)

- ▶ Secure the vehicle against rolling away (▷ page 199).
- ▶ Switch off all electrical consumers.
- ▶ Turn the key to position **0** in the ignition lock and remove it (▷ page 177).

or

- ▶ On vehicles with KEYLESS-GO, make sure the ignition is switched off (▷ page 177).

All indicator lamps in the instrument cluster must be off.

The fuses are located in various fuse boxes:

- Fuse box in the engine compartment on the left-hand side of the vehicle, when viewed in the direction of travel
- Fuse box in the boot/luggage compartment on the right-hand side of the vehicle, when viewed in the direction of travel



The fuse allocation chart is located in the vehicle tool kit in the stowage compartment under the boot/luggage compartment floor (▷ page 383).

Fuse box in the engine compartment

Observe the important safety notes
(▷ page 399)

WARNING

When the bonnet is open, and the windscreen wipers are set in motion, you can be injured by the wiper linkage. There is a risk of injury. Always switch off the windscreen wipers and the ignition before opening the bonnet.

- ▶  Make sure that no moisture can enter the fuse box when the cover is open.
- ▶  When closing the cover, make sure that it is lying correctly on the fuse box. Moisture seeping in or dirt could otherwise impair the operation of the fuses.
- ▶ Make sure that the windscreen wipers are switched off.
- ▶ Open the bonnet.

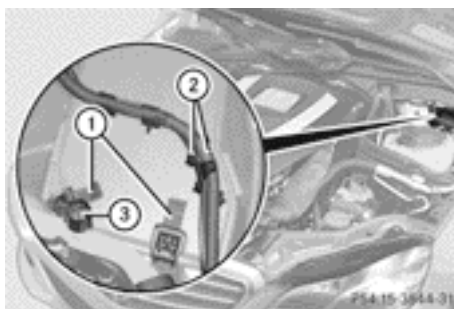

- ▶ Remove any existing moisture from the fuse box using a dry cloth.
- ▶ **To open:** take lines ② out of the guides.
- ▶ Move lines ② to one side. Route the lines behind connection ③ to do this.
- ▶ Open retaining clamps ①.
- ▶ Remove the fuse box cover forwards.
- ▶ **To close:** check whether the rubber seal is seated correctly in the cover.
- ▶ Insert the cover at the rear of the fuse box into the retainer.
- ▶ Fold down cover and close clamps ①.
- ▶ Secure lines ② in the guides.
- ▶ Close the bonnet.

Fuse box in the boot

Observe the important safety notes
(▷ page 399)

- ❗ Make sure that no moisture can enter the fuse box when the cover is open.
- ❗ When closing the cover, make sure that it is lying correctly on the fuse box. Moisture seeping in or dirt could otherwise impair the operation of the fuses.

- ▶ Open the boot lid.

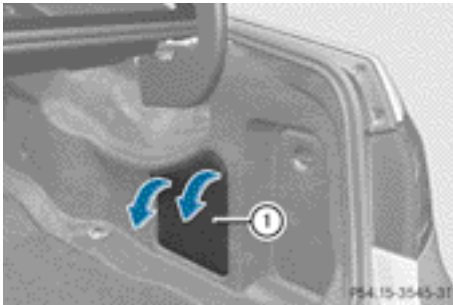

- ▶ **To open:** release cover ① at the top right and left-hand sides with a flat object.
- ▶ Open cover ① downwards in the direction of the arrow.

Fuse box in the luggage compartment

- ❗ Make sure that no moisture can enter the fuse box when the cover is open.
- ❗ When closing the cover, make sure that it is lying correctly on the fuse box. Moisture seeping in or dirt could otherwise impair the operation of the fuses.

- ▶ Open the tailgate.

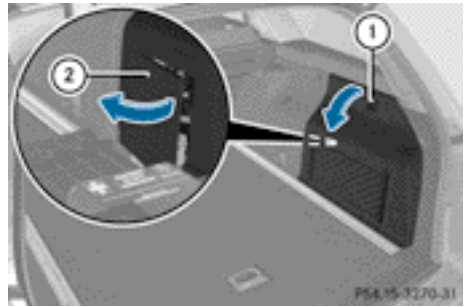

- ▶ **To open:** pull handle ① on the cover.
- ▶ Swing the cover down.
- ▶ Swing trim ② forwards.

Useful information	404
Important safety notes	404
Operation	404
Winter operation	406
Tyre pressure	407
Changing a wheel	413
Wheel and tyre combinations	419
Emergency spare wheel	459

Useful information

- i** This Owner's Manual describes all models, series and optional equipment for your vehicle that were available at the time of going to press. National variations are possible. Note that your vehicle may not be equipped with all of the functions described. This is also the case for systems and functions relevant to safety.
- i** Read the information on qualified specialist workshops: (▷ page 26).

Important safety notes

WARNING

If wheels and tyres of the wrong size are used, the wheel brakes or suspension components may be damaged. There is a risk of an accident.

Always replace wheels and tyres with those that fulfil the specifications of the original part.

When replacing wheels, make sure to fit the correct:

- designation
- type

When replacing tyres, make sure to fit the correct:

- designation
- manufacturer
- type

WARNING

A flat tyre severely impairs the driving, steering and braking characteristics of the vehicle. There is a risk of accident.

Tyres without run-flat characteristics:

- do not drive with a flat tyre.
- immediately replace the flat tyre with your emergency spare wheel or spare wheel, or consult a qualified specialist workshop.

Tyres with run-flat characteristics:

- pay attention to the information and warning notices on MOExtended tyres (tyres with run-flat characteristics).

Accessories that are not approved for your vehicle by Mercedes-Benz or are not being used correctly can impair the operating safety.

Before purchasing and using non-approved accessories, visit a qualified specialist workshop and enquire about:

- suitability
- legal stipulations
- factory recommendations

Information on the dimensions and types of wheels and tyres for your vehicle can be found under "Wheel/tyre combinations" (▷ page 419).

Information on air pressure for the tyres on your vehicle can be found:

- on the tyre pressure label on the fuel filler flap (▷ page 196)
- under "Tyre pressure" (▷ page 407)

Modification work on the brake system and wheels is not permitted. The use of wheel spacers or brake dust shields is not permitted. This invalidates the general operating permit for the vehicle.

- i** Further information on wheels and tyres can be obtained at any qualified specialist workshop.

Operation

Information on driving

Check the tyre pressures when the vehicle is heavily laden and, if necessary, adjust.

While driving, pay attention to vibrations, noises and unusual handling characteristics, e.g. pulling to one side. This may indicate that the wheels or tyres are damaged. If you suspect that a tyre is defective, reduce your speed immediately. Stop the vehicle as soon

as possible to check the wheels and tyres for damage. Hidden tyre damage could also be causing the unusual handling characteristics. If you find no signs of damage, have the tyres and wheels checked at a qualified specialist workshop.

When parking your vehicle, make sure that the tyres are not deformed by the kerb or other obstacles. If it is necessary to drive over kerbs, speed humps or similar elevations, try to do so slowly and at an obtuse angle. Otherwise, the tyres, particularly the sidewalls, may be damaged.

Regular checking of wheels and tyres

WARNING

Damaged tyres can cause tyre inflation pressure loss. As a result, you could lose control of your vehicle. There is a risk of accident.

Check the tyres regularly for signs of damage and replace any damaged tyres immediately.

Regularly check the wheels and tyres of your vehicle for damage at least once a month, as well as after driving off-road or on rough roads. Damaged wheels can cause a loss of tyre pressure. Pay particular attention to damage such as:

- cuts in the tyres
- punctures
- tears in the tyres
- bulges on tyres
- deformation or severe corrosion on wheels

Regularly check the tyre tread depth and the condition of the tread across the whole width of the tyre (▷ page 405). If necessary, turn the front wheels to full lock in order to inspect the inner side of the tyre surface.

All wheels must have a valve cap to protect the valve against dirt and moisture. Do not fit anything onto the valve other than the standard valve cap or other valve caps approved by Mercedes-Benz for your vehicle. Do not fit any

other valve caps or systems, e.g. tyre pressure monitoring systems.

Regularly check the pressure of all the tyres, particularly prior to long trips. Adjust the tyre pressure as necessary (▷ page 407).

Observe the notes on the emergency spare wheel (▷ page 459).

The service life of tyres depends on various factors, including the following:

- driving style
- tyre pressure
- mileage

Important safety notes on the tyre tread

WARNING

Insufficient tyre tread will reduce tyre traction. The tyre is no longer able to dissipate water. This means that on wet road surfaces, the risk of aquaplaning increases, in particular where speed is not adapted to suit the driving conditions. There is a risk of accident.

If the tyre pressure is too high or too low, tyres may exhibit different levels of wear at different locations on the tyre tread. Thus, you should regularly check the tread depth and the condition of the tread across the entire width of all tyres.

Minimum tyre tread depth for:

- summer tyres: 3 mm
- M+S tyres: 4 mm

For safety reasons, replace the tyres before the legally prescribed limit for the minimum tyre tread depth is reached..

Selecting, fitting and replacing tyres

- Only fit tyres and wheels of the same type and make.
Exception: it is permissible to fit a different type or make in the event of a flat tyre. Observe the "MOExtended tyres (tyres with

run-flat characteristics)" section (▷ page 385).

- Only fit tyres of the correct size onto the wheels.
- Run in new tyres at moderate speeds for the first 100 km. They only reach their full performance after this distance.
- Do not drive with tyres which have too little tread depth. This otherwise significantly reduces the traction on wet roads (aquaplaning).
- Replace the tyres after six years at the latest, regardless of wear.

Observe the notes on the emergency spare wheel (▷ page 459).

MOExtended tyres (tyres with run-flat characteristics)

With MOExtended tyres (tyres with run-flat characteristics), you can continue to drive your vehicle even if there is a total loss of pressure in one or more tyres.

Only use MOExtended tyres in conjunction with an activated tyre pressure loss warning system or tyre pressure monitoring system and only on tyres specifically inspected by Mercedes-Benz.

Notes on driving with MOExtended tyres with a flat tyre (▷ page 385).

- i** Vehicles with MOExtended tyres are not equipped with a TIREFIT kit at the factory. It is therefore recommended that you additionally equip your vehicle with a TIREFIT kit if you fit tyres that do not feature run-flat characteristics, e.g. winter tyres. A TIREFIT kit can be obtained from a qualified specialist workshop.

Winter operation

General notes

Have your vehicle winterproofed at a qualified specialist workshop at the onset of winter.

Observe the notes in the "Changing a wheel" section (▷ page 413).

Driving with summer tyres

At temperatures below +7 °C, summer tyres lose elasticity and therefore traction and braking power. Change the tyres on your vehicle to M+S tyres. Using summer tyres at very cold temperatures could cause tears to form, thereby damaging the tyres permanently. Mercedes-Benz cannot accept responsibility for this type of damage.

M+S tyres

WARNING

M+S tyres with a tyre tread depth of less than 4 mm are not suitable for use in winter as they do not provide sufficient traction. There is a risk of accident.

M+S tyres with a tread depth of less than 4 mm must be replaced.

At temperatures below +7 °C, use winter tyres or all-season tyres. Both types of tyre are identified by the M+S marking.

Only winter tyres bearing the  snowflake symbol in addition to the M+S marking provide the best possible grip in wintry road conditions.

Only these tyres will allow driving safety systems such as ABS and ESP® to function optimally in winter. These tyres have been developed specifically for driving in snow.

Use M+S tyres of the same make and tread on all wheels to maintain safe handling characteristics.

Always observe the maximum permissible speed specified for the M+S tyres you have fitted.

If you fit M+S tyres that have a lower maximum permissible speed than that of the vehicle, affix a corresponding warning label in the

driver's field of vision. This can be obtained at a qualified specialist workshop.

Under these circumstances, you should also restrict the maximum speed of the vehicle using permanent SPEEDTRONIC so that it does not exceed the maximum permissible speed for the M+S tyres (▷ page 211).

When you have fitted the M+S tyres:

- ▶ Check the tyre pressures (▷ page 407).
- ▶ Restart the tyre pressure loss warning system (▷ page 410).
- ▶ Restart the tyre pressure monitor (▷ page 412).

For more information on driving with an emergency spare wheel, see (▷ page 459).

Snow chains

WARNING

If you have fitted snow chains to the front wheels, they may scrape against the vehicle body or chassis components. This could cause damage to the vehicle or the tyres. There is a risk of an accident.

To avoid hazardous situations:

- never fit snow chains on the front wheels
- fit snow chains to the rear wheels in pairs.

! **Vehicles with steel wheels:** if you wish to fit snow chains to steel wheels, make sure that you remove the respective wheels' hubcaps first. The hubcaps may otherwise be damaged.

For safety reasons, Mercedes-Benz recommends that you only use snow chains that have been specially approved for your vehicle by Mercedes-Benz, or that are of a corresponding standard of quality.

If you intend to fit snow chains, please bear the following points in mind:

- snow chains cannot be fitted to all wheel-tyre combinations. Permissible wheel-tyre combinations (▷ page 419).
- only use snow chains when the road surface is completely snow-covered. Remove the snow chains as soon as possible when you come to a road that is not snow-covered.
- local regulations may restrict the use of snow chains. Observe the appropriate regulations if you wish to fit snow chains.
- do not exceed the maximum permissible speed of 50 km/h.
- on vehicles with AIRMATIC, you must drive at raised vehicle level if snow chains have been fitted (▷ page 224).

i You may wish to deactivate ESP® when pulling away with snow chains fitted (▷ page 78). This way you can allow the wheels to spin in a controlled manner, achieving an increased driving force (cutting action).

For more information on driving with an emergency spare wheel, see (▷ page 459).

Tyre pressure

Tyre pressure specifications

WARNING

Tyres with insufficient or excessive tyre pressure harbour the following hazards:

- the tyres may burst, especially as the load and vehicle speed increase.
- the tyres may wear excessively or unevenly which can severely impair tyre traction.
- the handling as well as steering and braking characteristics may be severely affected.

There is a risk of an accident.

10 kPa (0.1 bar/1.5 psi) per 10 °C. Take this into account when checking the pressure of warm tyres. Only correct the tyre pressure if it is too low for the current operating conditions.

Driving with tyre pressure that is too high or too low can:

- shorten the service life of the tyres
- cause increased tyre damage
- have a negative effect on handling characteristics and thus the driving safety (e.g. aquaplaning)

i The tyre pressure values given for low loads are minimum values which offer you good ride comfort characteristics.

However, you can also use the values given for higher loads. These are permissible and will not adversely affect the running of the vehicle.

Speeds up to 210 km/h: despite the values stated on the tyre pressure information label (fuel filler flap), for speeds up to 210 km/h with 16" or 17" tyres, the values stated can be reduced as follows, without a reduction in safety:

- **Saloon:**-30 kPa (-0.3 bar/-4 psi)
- **Estate:**-20 kPa (-0.2 bar/-3 psi)

This does not apply to vehicles towing a trailer.

This improves the ride comfort of your vehicle; however, fuel consumption may increase slightly.

Tyre pressure loss warning system

General notes

While the vehicle is in motion, the tyre pressure loss warning system monitors the set tyre pressure using the rotational speed of the wheels. This enables the system to detect significant pressure loss in a tyre. If the speed of rotation of a wheel changes as a result of a loss of pressure, a corresponding warning

message will appear in the multifunction display.

You can recognise the tyre pressure loss warning by the **Run Flat Indicator active Restart with OK** message which appears in the **Service** menu of the multifunction display. Information on the message display can be found in the "Restarting the tyre pressure loss warning system" section (> page 410).

Important safety notes

The tyre pressure warning system does not warn you of an incorrectly set tyre pressure. Observe the notes on the recommended tyre pressure (> page 407).

The tyre pressure loss warning does not replace the need to regularly check the tyre pressures. An even loss of pressure on several tyres at the same time cannot be detected by the tyre pressure loss warning system. The tyre pressure monitor is not able to warn you of a sudden loss of pressure, e.g. if the tyre is penetrated by a foreign object. In the event of a sudden loss of pressure, bring the vehicle to a halt by braking carefully. Avoid abrupt steering manoeuvres.

The function of the tyre pressure loss warning system is limited or delayed if:

- snow chains are fitted to your vehicle's tyres.
- road conditions are wintry.
- you are driving on sand or gravel.
- you adopt a very sporty driving style (cornering at high speeds or driving with high rates of acceleration).
- you are towing a very heavy or large trailer.
- you are driving with a heavy load (in the vehicle or on the roof).

Restarting the tyre pressure loss warning system

Restart the tyre pressure loss warning system if you have:

- changed the tyre pressure
 - changed the wheels or tyres
 - fitted new wheels or tyres
- ▶ Before restarting, make sure that the tyre pressures are set properly on all four tyres for the respective operating conditions. The recommended tyre pressures can be found in the tyre pressure table on the fuel filler flap.

The tyre pressure loss warning system can only give reliable warnings if you have set the correct tyre pressure. If an incorrect tyre pressure is set, these incorrect values will be monitored.

- ▶ Observe the notes in the section on tyre pressures (▷ page 407).
- ▶ Make sure that the key is in position 2 in the ignition lock (▷ page 177).
- ▶ Press the ◀ or ▶ button on the steering wheel to select the **Serv.** menu.
- ▶ Press the ▲ or ▼ button on the steering wheel to select the **Tyre pressure** menu.
- ▶ Press the **OK** button.
The **Run Flat Indicator active Restart with OK** message appears in the multifunction display.

If you wish to confirm the restart:

- ▶ Press the **OK** button.
The **Tyre press. now OK?** message appears in the multifunction display.
- ▶ Press the ▲ or ▼ button to select **Yes**.
- ▶ Press the **OK** button.
The **Run Flat Indicator restarted** message appears in the multifunction display.

After a teach-in period, the tyre pressure loss warning system will monitor the set tyre pressures of all four tyres.

If you wish to cancel the restart:

- ▶ Press the ◀ button.
- or
- ▶ When the **Tyre press. now OK?** message appears, press the ▲ or ▼ button to select **Cancel**.
 - ▶ Press the **OK** button.
The tyre pressure values stored at the last restart will continue to be monitored.

Tyre pressure monitor

General notes

If a tyre pressure monitor system is fitted, the vehicle's wheels have sensors fitted that monitor the tyre pressures in all four tyres. The tyre pressure monitor warns you if the pressure drops in one or more of the tyres. The tyre pressure monitor only functions if the corresponding sensors are fitted to all wheels.

Information on tyre pressures is shown in the multifunction display. After a few minutes of driving, the current tyre pressure of each tyre is shown in the **Serv.** menu of the multifunction display.



Example: current tyre pressure display

For further information on displaying this message, refer to the "Checking the tyre pressure electronically" section (▷ page 411).

Important safety notes

It is the driver's responsibility to set the tyre pressure to the recommended cold tyre pressure suitable for the operating situation (▷ page 407). Note that the correct tyre pressure for the current operating situation must first be taught-in to the tyre pressure monitor. If there is a substantial loss of pressure, the warning threshold for the warning message is aligned to the reference values taught-in. Restart the tyre pressure monitor after adjusting to the cold tyre pressure (▷ page 412). The current pressures are saved as new reference values. This will ensure that a warning message will only appear if the tyre pressure drops significantly. The tyre pressure monitor does not warn you of an incorrectly set tyre pressure. Observe the notes on the recommended tyre pressure (▷ page 407).

The tyre pressure monitor is not able to warn you of a sudden loss of pressure, e.g. if the tyre is penetrated by a foreign object. In the event of a sudden loss of pressure, bring the vehicle to a halt by braking carefully. Avoid abrupt steering manoeuvres.

The tyre pressure monitor has a yellow warning lamp in the instrument cluster for indicating a pressure loss or malfunction. Depending on how the warning lamp flashes or lights up, a tyre pressure that is too low or a malfunction in the tyre pressure monitor is indicated:

- if the warning lamp is lit continuously, the tyre pressure on one or more tyres is significantly too low. The tyre pressure monitor is not malfunctioning.
- if the warning lamp flashes for around a minute and then remains lit constantly, the tyre pressure monitor is malfunctioning.

i In addition to the warning lamp, a message appears in the multifunction display. Further information can be found at (▷ page 312).

If the tyre pressure monitor is malfunctioning, it may take more than ten minutes for the tyre

pressure warning lamp to inform you of the malfunction by flashing for approximately one minute and then remaining lit. When the fault has been rectified, the tyre pressure warning lamp goes out after you have driven for a few minutes.

The tyre pressure values indicated by the on-board computer may differ from those measured at a filling station using a pressure gauge. The tyre pressures shown by the on-board computer refer to those measured at sea level. At high altitudes, the tyre pressure values indicated by a pressure gauge are higher than those shown by the on-board computer. In this case, do not reduce the tyre pressures.

The operation of the tyre pressure monitor can be affected by interference from radio transmitting equipment (e.g. radio head-phones, two-way radios) that may be being operated in or near the vehicle.

Checking the tyre pressure electronically

- ▶ Make sure that the key is in position **2** in the ignition lock (▷ page 177).
- ▶ Press the ◀ or ▶ button on the steering wheel to select the **Service** menu.
- ▶ Press the ▲ or ▼ button to select **Tyre pressure**.
- ▶ Press the **OK** button.

The current tyre pressure for each wheel will be displayed in the multifunction display.

If the vehicle has been parked for over 20 minutes, the **Tyre pressures will be displayed after a few minutes of driving** message appears.

After a teach-in period, the tyre pressure monitor automatically recognises new wheels or new sensors. As long as a clear allocation of the tyre pressure values to the individual wheels is not possible, the **Tyre pressure monitor active** display message is shown instead of the tyre pressure

display. The tyre pressures are already being monitored.

- ❗ If an emergency spare wheel is fitted, the system may continue to show the tyre pressure of the wheel that has been removed for a few minutes. If this occurs, note that the value displayed for the position where the spare wheel is fitted is not the same as the current tyre pressure of the emergency spare wheel.

Warning messages of the tyre pressure monitor

If the tyre pressure monitor detects a pressure loss in one or more tyres, a warning message is shown in the multifunction display and the yellow tyre pressure monitor warning light comes on.

- If the **Please correct tyre pressure** message appears in the multifunction display, the tyre pressure in at least one tyre is too low and must be corrected at the next opportunity.
- If the **Check tyre(s)** message appears in the multifunction display, the tyre pressure in one or more tyres has dropped significantly and the tyres must be checked.
- If the **Warning tyre defect** message appears in the multifunction display, the tyre pressure in one or more tyres has dropped suddenly and the tyres must be checked.

Observe the instructions and safety notes in the display messages in the "Tyres" section (▷ page 312).





- ❗ If the wheel positions on the vehicle are interchanged, the tyre pressures may be displayed for the wrong positions for a short time. This is rectified after a few minutes of driving and the tyre pressures are displayed for the correct positions.

Restarting the tyre pressure monitor

When you restart the tyre pressure monitor, all existing warning messages are deleted and the warning lamps go out. The monitor uses the currently set tyre pressures as the reference values for monitoring. In most cases, the tyre pressure monitor will automatically detect the new reference values after you have changed the tyre pressure. However, you can also define reference values manually as described here. The tyre pressure monitor then monitors the new tyre pressure values.

- ▶ Use the table on the inside of the fuel filler flap to ensure that the tyre pressure is set correctly in all four tyres for the current operating conditions.

Also observe the notes in the section on tyre pressures (▷ page 407).

- ▶ Make sure that the key is in position **2** in the ignition lock.
- ▶ Press the  or  button on the steering wheel to select the **Service** menu.
- ▶ Press the  or  button to select **Tyre pressure**.
- ▶ Press the  button.

The multifunction display shows the current tyre pressure for the individual tyres or the **Tyre pressures will be displayed after a few minutes of driving** message.

- ▶ Press the  button.

The **Use current pressures as new reference values** message appears in the multifunction display.

If you wish to confirm the restart:

- ▶ Press the  button.

The **Tyre press. monitor restarted** message appears in the multifunction display.

After you have driven for a few minutes, the system checks whether the current tyre pressures are within the specified range.

The new tyre pressures are then accepted as reference values and monitored.

If you wish to cancel the restart:

- ▶ Press the  button.

The tyre pressure values stored at the last restart will continue to be monitored.

Radio type approval for the tyre pressure monitor

Country	Radio type approval number
Brazil	1489-10-44 15 Model: MRXMERTX1
Dubai	TRA, Registered NO 0016161/08 TRA, Registered NO ER0076990/11 Dealer-NO: DA0047074/10
Morocco	MR5526 ANRT 2010/ 27/04/2010 MR6706 ANRT 2011/ 17/11/2011
Philippines	ESD-1105558C
Serbia	И 011 12
Singapore	Compliance with IDA Standard N0140-09
South Africa	TA-2008/1068 TA-2011/1370

Changing a wheel

Flat tyre

You can find information on what to do in the event of a flat tyre in the "Breakdown assistance" section (▷ page 385). Information on driving with MOExtended tyres in the event of a flat tyre can be found under "Breakdown assistance" (▷ page 385).

Vehicles with an emergency spare

wheel: in the event of a flat tyre, the emergency spare wheel is fitted according to the description under "Fitting a wheel"

(▷ page 414).

Interchanging the wheels

WARNING

Interchanging the front and rear wheels may severely impair the driving characteristics if the wheels or tyres have different dimensions. The wheel brakes or suspension components may also be damaged. There is a risk of accident.

Interchange front and rear wheels only if the wheels and tyres are of the same dimensions.

- ❗ On vehicles fitted with a tyre pressure monitor, electronic components are located in the wheel.

Tyre-fitting tools should not be applied in the area of the valve, as this could damage the electronic components.

Only have tyres changed at a qualified specialist workshop.

Interchanging the front and rear wheels of differing dimensions can render the general operating permit invalid.

Observe the instructions and safety notes in the "Fitting a wheel" section (▷ page 414).

The wear patterns on the front and rear tyres differ, depending on the operating conditions. Interchange the wheels before a clear wear pattern has formed on the tyres. Front tyres typically wear more on the shoulders and the rear tyres in the centre.

On vehicles that have the same size front and rear wheels, you can interchange the wheels every 5,000 to 10,000 km depending on the degree of tyre wear. Ensure the direction of rotation is maintained.

Clean the contact surfaces of the wheel and the brake disc thoroughly every time a wheel is interchanged. Check the tyre pressure and,

if necessary, restart the tyre pressure loss warning system or the tyre pressure monitor.

Direction of rotation

Tyres with a specified direction of rotation have additional benefits, e.g. if there is a risk of aquaplaning. You will only gain these benefits if the correct direction of rotation is observed.

An arrow on the sidewall of the tyre indicates its correct direction of rotation.

Storing wheels

Store wheels that are not being used in a cool, dry and preferably dark place. Protect the tyres against oil, grease, petrol and diesel.

Cleaning the wheels

WARNING

The water jet of circular-jet nozzles (dirt grinders) can cause damage not visible from the outside to tyres or chassis components. Components damaged in this way can unexpectedly fail. There is a risk of an accident.

Do not use high-pressure cleaners with circular-jet nozzles to clean the vehicle. Have damaged tyres or chassis components replaced immediately.

Fitting a wheel

Preparing the vehicle

- ▶ Stop the vehicle on solid, non-slippery and level ground.
- ▶ Apply the parking brake.
- ▶ Move the front wheels to the straight-ahead position.
- ▶ **Vehicles with manual transmission:** depress the clutch pedal fully and engage first or reverse gear.

- ▶ **Vehicles with automatic transmission:** shift the transmission to position **P**.

- ▶ Vehicles with AIRMATIC: make sure that "normal" vehicle level is selected (▷ page 224).

- ▶ Switch off the engine.

- ▶ **Vehicles without KEYLESS-GO:** remove the key from the ignition lock.

- ▶ **Vehicles with KEYLESS-GO:** open the driver's door.

The on-board electronics now have status **0**. This is the same as the key having been removed.

- ▶ **Vehicles with KEYLESS-GO:** remove the Start/Stop button from the ignition lock (▷ page 177).

- ▶ If included in the vehicle equipment, remove the tyre-change tool kit from the vehicle (▷ page 383).

- ▶ Secure the vehicle to prevent it from rolling away.

- i** Apart from some country-specific variants, vehicles are not equipped with tyre-changing tools. Some tools for changing a wheel are specific to the vehicle. For more information on which tools are required to perform a wheel change on your vehicle, consult a qualified specialist workshop. Necessary wheel-changing tools may include, for example:

- jack
- wheel chock
- wheel wrench

Securing the vehicle against rolling away

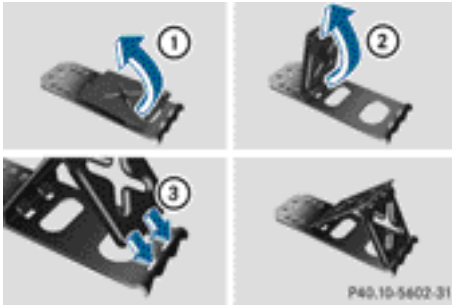

If your vehicle is equipped with a wheel chock, it can be found in the tyre-change tool kit (▷ page 383).

The folding wheel chock is an additional securing measure to prevent the vehicle from rolling away, for example when changing a wheel.

- ▶ Fold both plates upwards ①.
- ▶ Fold out lower plate ②.
- ▶ Guide the lugs on the lower plate fully into the openings in base plate ③.



Securing the vehicle on level ground (example: Saloon)

- ▶ **On level ground:** place chocks or other suitable items under the front and rear of the wheel that is diagonally opposite the wheel you wish to change.



Securing the vehicle on slight downhill gradients (example: Saloon)

- ▶ **On light downhill gradients:** place chocks or other suitable items in front of the wheels of the front and rear axle.

Raising the vehicle

WARNING

If you do not position the jack correctly at the appropriate jacking point of the vehicle, the jack could tip over with the vehicle raised. There is a risk of injury.

Only position the jack at the appropriate jacking point of the vehicle. The base of the jack must be positioned vertically, directly under the jacking point of the vehicle.

Observe the following when raising the vehicle:

- to raise the vehicle, only use the vehicle-specific jack that has been tested and approved by Mercedes-Benz. If the jack is used incorrectly, it could tip over while the vehicle is raised.
- the jack is designed only to raise and hold the vehicle for a short time while a wheel is being changed. It is not suitable for performing maintenance work under the vehicle.
- avoid changing the wheel on uphill and downhill slopes.
- before raising the vehicle, secure it from rolling away by applying the parking brake and positioning wheel chocks. Never

release the parking brake while the vehicle is raised.

- the jack must be placed on a firm, flat and non-slip surface. On a loose surface, a large, load-bearing underlay must be used. On a slippery surface, a non-slip underlay must be used, e.g. rubber mats.
- do not use wooden blocks or similar objects as a jack underlay. Otherwise, the jack will not be able to achieve its load-bearing capacity due to the restricted height.
- make sure that the distance between the underside of the tyres and the ground does not exceed 3 cm.
- never place your hands or feet under the raised vehicle.
- never lie under the raised vehicle.
- never start the engine when the vehicle is raised.
- never open or close a door or the boot lid/ tailgate when the vehicle is raised.
- make sure that no persons are present in the vehicle when the vehicle is raised.

AMG vehicles with Performance Studio

equipment: the wheel bolts are covered by a hub cap. Before you are able to unscrew the wheel bolts, you must first remove the hub cap.

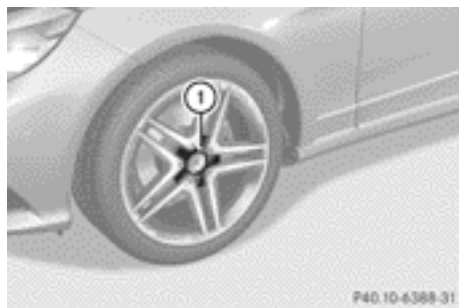

- ▶ **To remove:** turn the centre cover of hub cap ① anti-clockwise and remove.
- ▶ **To fit:** before fitting, ensure that hub cap ① is in the open position. To do so, turn the centre cover anti-clockwise.

- ▶ Put hub cap ① in position and turn the centre cover clockwise until you feel and hear hub cap ① engage.

- ▶ Make sure that hub cap ① is fitted securely.

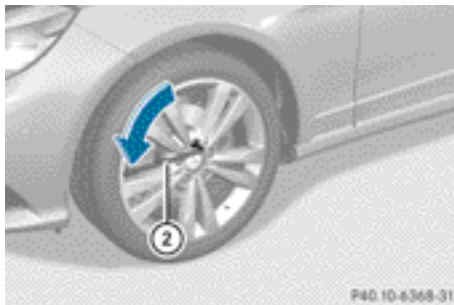

- ▶ Using wheel wrench ②, loosen the bolts on the wheel you wish to change by about one full turn. Do not unscrew the bolts completely.

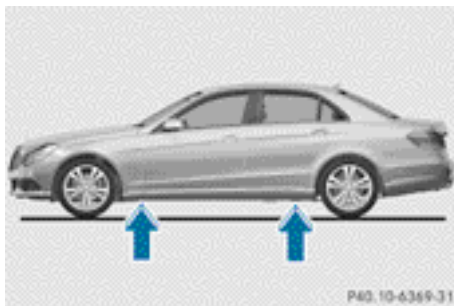

Jacking points (example: Saloon)

The jacking points are located just behind the front wheel arches and just in front of the rear wheel arches (arrows).

AMG vehicles and vehicles with AMG

equipment: the vehicle has covers to protect the vehicle body fitted next to the jacking points on the outer sills.

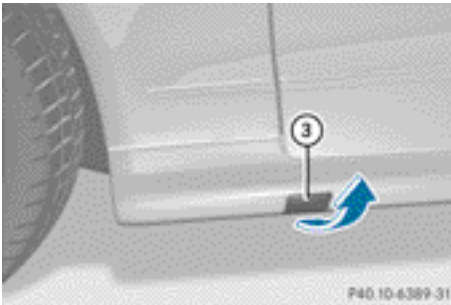

Covers, front (example: vehicles with AMG Sports package)

- ▶ **AMG vehicles and vehicles with AMG equipment:** fold cover ③ upwards.

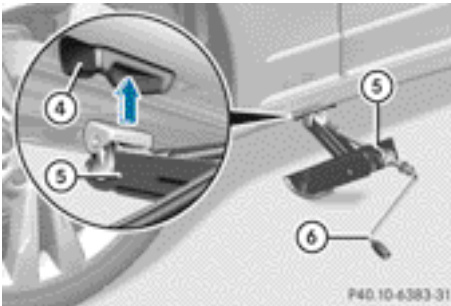

- ▶ Position jack ⑤ at jacking point ④.

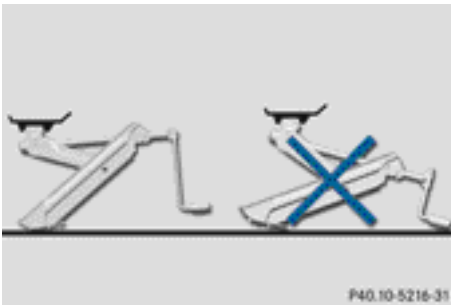

Example

- ▶ Make sure that the base of the jack is positioned vertically under the jacking point.

- ▶ Turn crank ⑥ clockwise until jack ⑤ sits completely on jacking point ④ and the base of the jack lies evenly on the ground.
- ▶ Turn crank ⑥ until the tyre is raised a maximum of three centimetres off the ground.

Removing a wheel

! **AMG vehicles:** during removal and repositioning of the wheel, the wheel rim can strike the ceramic-brake disc and damage it. Therefore, take precautions and get a second person to assist you. Alternatively, you can use a second centring pin.

! Do not place wheel bolts in sand or dirt. The threads of the wheel bolts and wheel hubs could otherwise be damaged when the bolts are tightened.

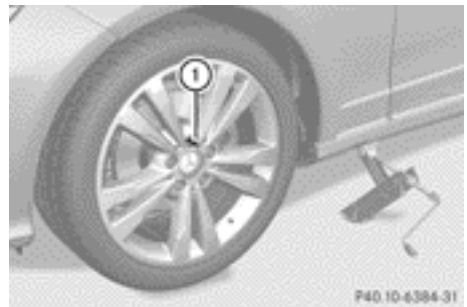

- ▶ Unscrew the uppermost wheel bolt completely.
- ▶ Screw centring pin ① into the thread instead of the wheel bolt.
- ▶ Unscrew the remaining wheel bolts fully.
- ▶ Remove the wheel.

Fitting a new wheel

⚠ WARNING

Oiled or greased wheel bolts or damaged wheel bolts/hub threads can cause the wheel bolts to come loose. As a result, you could lose a wheel while driving. There is a risk of accident.

Never oil or grease wheel bolts. In the event of damage to the threads, contact a qualified specialist workshop immediately. Have the damaged wheel bolts or hub threads replaced/renewed. Do not continue driving.

WARNING

If you tighten the wheel bolts or wheel nuts when the vehicle is raised, the jack could tip over. There is a risk of injury.

Only tighten the wheel bolts or wheel nuts when the vehicle is on the ground.

Always pay attention to the instructions and safety notices in "Changing a wheel" (▷ page 413).

Only use wheel bolts that have been designed for the wheel and the vehicle. For safety reasons, Mercedes-Benz recommends that you only use wheel bolts which have been approved for Mercedes-Benz vehicles and the respective wheel.

! **AMG vehicles:** during removal and repositioning of the wheel, the wheel rim can strike the ceramic-brake disc and damage it. Therefore, take precautions and get a second person to assist you. Alternatively, you can use a second centring pin.

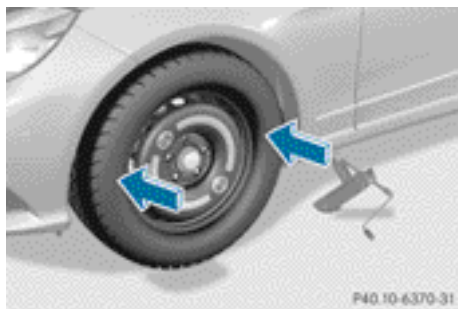

Attaching a wheel (example: vehicle with emergency spare wheel)

- ▶ Clean the wheel and wheel hub contact surfaces.
- ▶ Slide the wheel to be mounted onto the centring pin and push it on.

- ▶ Tighten the wheel bolts until they are finger-tight.
- ▶ Unscrew the centring pin.
- ▶ Tighten the last wheel bolt until it is finger-tight.
- ▶ **Vehicles with a collapsible emergency spare wheel:** inflate the collapsible emergency spare wheel (▷ page 461).
Only then lower the vehicle.

Lowering the vehicle

WARNING

The wheels could work loose if the wheel nuts and bolts are not tightened to the specified tightening torque. There is a risk of accident. Have the tightening torque immediately checked at a qualified specialist workshop after a wheel is changed.

- ▶ **Vehicles with a collapsible emergency spare wheel:** Inflate the collapsible emergency spare wheel using the tyre inflation compressor before lowering the vehicle. The rim could otherwise be damaged.

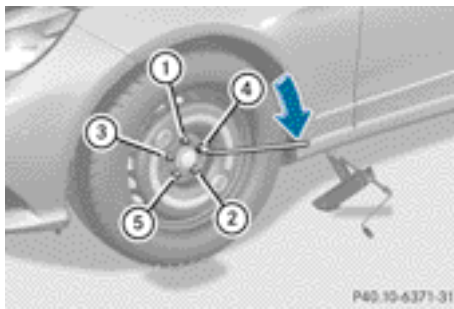

Tightening the wheel bolts (example: vehicle with emergency spare wheel)

- ▶ Turn the crank of the jack anti-clockwise until the vehicle is once again standing firmly on the ground.
- ▶ Place the jack to one side.
- ▶ Tighten the wheel bolts evenly in a cross-wise pattern in the sequence indicated (① to ⑤). The specified tightening torque is **130 Nm**.

- ▶ Turn the jack back to its initial position.
- ▶ Stow the jack and the rest of the vehicle tools in the boot/load compartment again.
- ▶ **AMG vehicles and vehicles with AMG equipment:** insert the cover into the outer sill.
- ▶ Check the air pressure of the newly fitted wheel and adjust accordingly.
Observe the recommended tyre pressure (▷ page 407).

i Vehicles with a tyre pressure control system: all fitted wheels must be equipped with functioning sensors.

Wheel and tyre combinations

General notes

! For safety reasons, Mercedes-Benz recommends that you only use tyres and wheels which have been approved by Mercedes-Benz specifically for your vehicle.

These are specially adapted to the control systems, such as ABS or ESP® and are marked as follows:

- MO = Mercedes-Benz Original
- MOE = Mercedes-Benz Original Extended (tyres featuring run-flat characteristics)
- MO1 = Mercedes-Benz Original (only certain AMG tyres)

Mercedes-Benz Original Extended tyres may only be used on wheels that have been specifically approved by Mercedes-Benz.

Only use tyres, wheels or accessories tested and approved by Mercedes-Benz. Certain characteristics, e.g. handling, vehicle noise emissions or fuel consumption, may otherwise be adversely affected. In addition, when driving with a load, tyre dimension variations could cause the tyres to come into contact with the bodywork and axle components. This could result in damage to the tyres or the vehicle.

Mercedes-Benz accepts no liability for damage resulting from the use of tyres, wheels or accessories other than those tested and approved.

Further information about wheels, tyres and approved combinations can be obtained from any qualified specialist workshop.

! Retreaded tyres are neither tested nor recommended by Mercedes-Benz, since previous damage cannot always be detected on retreaded tyres. As a result, Mercedes-Benz cannot guarantee vehicle safety if retreaded tyres are fitted. Do not fit used tyres if you have no information about their previous usage.

! Large wheels: the lower the section width for a certain wheel size, the lower the ride comfort is on poor road surfaces. Roll comfort and suspension comfort are reduced and the risk of damage to the wheels and tyres as a result of driving over obstacles increases.

Overview of abbreviations used in the following tyre tables:

- BA: both axles
- FA: front axle
- RA: rear axle

You will find a table with recommended tyre pressures for various operating conditions on the inside of your vehicle's fuel filler flap. For further information on tyre pressure, see (▷ page 407). Check tyre pressures regularly and only when the tyres are cold.

Notes on the vehicle equipment – always fit the vehicle:

- with tyres of the same size on a given axle (left/right)
- with the same type of tyres at a given time (summer tyres, winter tyres, MOExtended tyres)

Vehicles with MOExtended tyres are not equipped with a TIREFIT kit at the factory. It is therefore recommended that you addition-

ally equip your vehicle with a TIREFIT kit if you fit tyres that do not feature run-flat characteristics, e.g. winter tyres. A TIREFIT kit can be obtained from a qualified specialist workshop.

- i** Not all wheel/tyre combinations can be mounted at the factory in all countries.

Tyres**E 180****Summer tyres****R16**

Tyres	Light-alloy wheels
BA: 205/60 R16 92 W ²	BA: 7.0 J x 16 H2 ET 38
BA: 225/55 R16 95 W ²	BA: 7.5 J x 16 H2 ET 45.5
BA: 225/55 R16 99 W XL ³	BA: 7.5 J x 16 H2 ET 45.5
BA: 225/55 R16 99 Y XL ³	BA: 7.5 J x 16 H2 ET 45.5
BA: 225/55 R16 95 W ²	BA: 8.0 J x 16 H2 ET 46
BA: 225/55 R16 99 W XL ³	BA: 8.0 J x 16 H2 ET 46
BA: 225/55 R16 99 Y XL ³	BA: 8.0 J x 16 H2 ET 46

R17

Tyres	Light-alloy wheels
BA: 245/45 R17 95 W ²	BA: 8.0 J x 17 H2 ET 48
BA: 245/45 R17 99 Y XL ³	BA: 8.0 J x 17 H2 ET 48
BA: 245/45 R17 99 Y XL MOExtended ⁴	BA: 8.0 J x 17 H2 ET 48
BA: 245/45 R17 95 W ²	BA: 8.5 J x 17 H2 ET 48
BA: 245/45 R17 99 Y XL ³	BA: 8.5 J x 17 H2 ET 48
BA: 245/45 R17 99 Y XL MOExtended ⁴	BA: 8.5 J x 17 H2 ET 48

R18

Tyres	Light-alloy wheels
BA: 245/40 R18 97 Y XL ³	BA: 8.5 J x 18 H2 ET 48
FA: 245/40 R18 97 Y XL	FA: 8.5 J x 18 H2 ET 48
RA: 265/35 R18 97 Y XL ⁵	RA: 9.0 J x 18 H2 ET 54

² Only for Saloon.

³ Only for Estate.

⁴ MOExtended tyres (tyres featuring run-flat characteristics) only in combination with an active tyre pressure loss warning system or tyre pressure monitor.





⁵ Use of snow chains not permitted. Observe the notes under "Snow chains".

R19







Tyres	Light-alloy wheels
FA: 245/35 R19 93 Y XL ^{6, 7, 8}	FA: 8.5 J x 19 H2 ET 48
RA: 275/30 R19 96 Y XL ^{5, 6, 7, 8}	RA: 9.5 J x 19 H2 ET 48

Winter tyres

R16

Tyres	Light-alloy wheels
BA: 205/60 R16 92 H M+S  ²	BA: 7.0 J x 16 H2 ET 38
BA: 225/55 R16 95 H M+S  ²	BA: 7.5 J x 16 H2 ET 45.5
BA: 225/55 R16 99 H XL M+S  ³	BA: 7.5 J x 16 H2 ET 45.5
BA: 225/55 R16 95 H M+S  ²	BA: 8.0 J x 16 H2 ET 46
BA: 225/55 R16 99 H XL M+S  ³	BA: 8.0 J x 16 H2 ET 46

R17

Tyres	Light-alloy wheels
BA: 245/45 R17 95 H M+S  ²	BA: 8.0 J x 17 H2 ET 48
BA: 245/45 R17 99 H XL M+S  ³	BA: 8.0 J x 17 H2 ET 48
BA: 245/45 R17 99 H XL M+S  MOExtended ⁴	BA: 8.0 J x 17 H2 ET 48
BA: 245/45 R17 95 H M+S  ²	BA: 8.5 J x 17 H2 ET 48
BA: 245/45 R17 99 H XL M+S  ³	BA: 8.5 J x 17 H2 ET 48
BA: 245/45 R17 99 H XL M+S  MOExtended ⁴	BA: 8.5 J x 17 H2 ET 48

⁶ Only in combination with AIRMATIC (code 489), DIRECT CONTROL suspension (code 677) or Sports package (code 950).

⁷ Not in combination with trailer tow hitch (code 550) or folding bench seat (code 844) (Estate).

⁸ Observe notes on "Large wheels" under "General notes" in "Wheel and tyre combination".

⁵ Use of snow chains not permitted. Observe the notes under "Snow chains".

² Only for Saloon.

³ Only for Estate.

⁴ MOExtended tyres (tyres featuring run-flat characteristics) only in combination with an active tyre pressure loss warning system or tyre pressure monitor.

R18

Tyres	Light-alloy wheels
BA: 245/40 R18 97 H XL M+S 	BA: 8.5 J x 18 H2 ET 48

E 200

Summer tyres

R16

Tyres	Light-alloy wheels
BA: 205/60 R16 92 W ²	BA: 7.0 J x 16 H2 ET 38
BA: 225/55 R16 95 W ²	BA: 7.5 J x 16 H2 ET 45.5
BA: 225/55 R16 99 W XL ³	BA: 7.5 J x 16 H2 ET 45.5
BA: 225/55 R16 99 Y XL ³	BA: 7.5 J x 16 H2 ET 45.5
BA: 225/55 R16 95 W ²	BA: 8.0 J x 16 H2 ET 46
BA: 225/55 R16 99 W XL ³	BA: 8.0 J x 16 H2 ET 46
BA: 225/55 R16 99 Y XL ³	BA: 8.0 J x 16 H2 ET 46

R17

Tyres	Light-alloy wheels
BA: 245/45 R17 95 W ²	BA: 8.0 J x 17 H2 ET 48
BA: 245/45 R17 99 Y XL ³	BA: 8.0 J x 17 H2 ET 48
BA: 245/45 R17 99 Y XL MOExtended ⁴	BA: 8.0 J x 17 H2 ET 48
BA: 245/45 R17 95 W ²	BA: 8.5 J x 17 H2 ET 48
BA: 245/45 R17 99 Y XL ³	BA: 8.5 J x 17 H2 ET 48
BA: 245/45 R17 99 Y XL MOExtended ⁴	BA: 8.5 J x 17 H2 ET 48

² Only for Saloon.

³ Only for Estate.

⁴ MOExtended tyres (tyres featuring run-flat characteristics) only in combination with an active tyre pressure loss warning system or tyre pressure monitor.

R18



Tyres	Light-alloy wheels
BA: 245/40 R18 97 Y XL ³	BA: 8.5 J x 18 H2 ET 48
FA: 245/40 R18 97 Y XL	FA: 8.5 J x 18 H2 ET 48
RA: 265/35 R18 97 Y XL ⁵	RA: 9.0 J x 18 H2 ET 54

R19



Tyres	Light-alloy wheels
FA: 245/35 R19 93 Y XL ^{6,7,8}	FA: 8.5 J x 19 H2 ET 48
RA: 275/30 R19 96 Y XL ^{5,6,7,8}	RA: 9.5 J x 19 H2 ET 48

Winter tyres



R16

Tyres	Light-alloy wheels
BA: 205/60 R16 92 H M+S  ²	BA: 7.0 J x 16 H2 ET 38
BA: 225/55 R16 95 H M+S  ²	BA: 7.5 J x 16 H2 ET 45.5
BA: 225/55 R16 99 H XL M+S  ³	BA: 7.5 J x 16 H2 ET 45.5
BA: 225/55 R16 95 H M+S  ²	BA: 8.0 J x 16 H2 ET 46
BA: 225/55 R16 99 H XL M+S  ³	BA: 8.0 J x 16 H2 ET 46

R17

Tyres	Light-alloy wheels
BA: 245/45 R17 95 H M+S  ²	BA: 8.0 J x 17 H2 ET 48
BA: 245/45 R17 99 H XL M+S  ³	BA: 8.0 J x 17 H2 ET 48
BA: 245/45 R17 99 H XL M+S  MOExtended ⁴	BA: 8.0 J x 17 H2 ET 48

³ Only for Estate.⁵ Use of snow chains not permitted. Observe the notes under "Snow chains".⁶ Only in combination with AIRMATIC (code 489), DIRECT CONTROL suspension (code 677) or Sports package (code 950).⁷ Not in combination with trailer tow hitch (code 550) or folding bench seat (code 844) (Estate).⁸ Observe notes on "Large wheels" under "General notes" in "Wheel and tyre combination".² Only for Saloon.⁴ MOExtended tyres (tyres featuring run-flat characteristics) only in combination with an active tyre pressure loss warning system or tyre pressure monitor.

Tyres	Light-alloy wheels
BA: 245/45 R17 95 H M+S  ²	BA: 8.5 J x 17 H2 ET 48
BA: 245/45 R17 99 H XL M+S  ³	BA: 8.5 J x 17 H2 ET 48
BA: 245/45 R17 99 H XL M+S  MOExtended ⁴	BA: 8.5 J x 17 H2 ET 48

R18

Tyres	Light-alloy wheels
BA: 245/40 R18 97 H XL M+S 	BA: 8.5 J x 18 H2 ET 48

E 200 CDI

Summer tyres

R16

Tyres	Light-alloy wheels
BA: 205/60 R16 92 W ²	BA: 7.0 J x 16 H2 ET 38
BA: 225/55 R16 95 W ²	BA: 7.5 J x 16 H2 ET 45.5
BA: 225/55 R16 99 W XL ³	BA: 7.5 J x 16 H2 ET 45.5
BA: 225/55 R16 99 Y XL ³	BA: 7.5 J x 16 H2 ET 45.5
BA: 225/55 R16 95 W ²	BA: 8.0 J x 16 H2 ET 46
BA: 225/55 R16 99 W XL ³	BA: 8.0 J x 16 H2 ET 46
BA: 225/55 R16 99 Y XL ³	BA: 8.0 J x 16 H2 ET 46

R17

Tyres	Light-alloy wheels
BA: 245/45 R17 95 W ²	BA: 8.0 J x 17 H2 ET 48
BA: 245/45 R17 99 Y XL ³	BA: 8.0 J x 17 H2 ET 48
BA: 245/45 R17 99 Y XL MOExtended ⁴	BA: 8.0 J x 17 H2 ET 48
BA: 245/45 R17 95 W ²	BA: 8.5 J x 17 H2 ET 48

² Only for Saloon.

³ Only for Estate.

⁴ MOExtended tyres (tyres featuring run-flat characteristics) only in combination with an active tyre pressure loss warning system or tyre pressure monitor.

Tyres	Light-alloy wheels
BA: 245/45 R17 99 Y XL ³	BA: 8.5 J x 17 H2 ET 48
BA: 245/45 R17 99 Y XL MOExtended ⁴	BA: 8.5 J x 17 H2 ET 48



R18

Tyres	Light-alloy wheels
BA: 245/40 R18 97 Y XL ³	BA: 8.5 J x 18 H2 ET 48
FA: 245/40 R18 97 Y XL	FA: 8.5 J x 18 H2 ET 48
RA: 265/35 R18 97 Y XL ⁵	RA: 9.0 J x 18 H2 ET 54

R19







Tyres	Light-alloy wheels
FA: 245/35 R19 93 Y XL ^{6,7,8}	FA: 8.5 J x 19 H2 ET 48
RA: 275/30 R19 96 Y XL ^{5,6,7,8}	RA: 9.5 J x 19 H2 ET 48

Winter tyres**R16**

Tyres	Light-alloy wheels
BA: 205/60 R16 92 H M+S  ²	BA: 7.0 J x 16 H2 ET 38
BA: 225/55 R16 95 H M+S  ²	BA: 7.5 J x 16 H2 ET 45.5
BA: 225/55 R16 99 H XL M+S  ³	BA: 7.5 J x 16 H2 ET 45.5
BA: 225/55 R16 95 H M+S  ²	BA: 8.0 J x 16 H2 ET 46
BA: 225/55 R16 99 H XL M+S  ³	BA: 8.0 J x 16 H2 ET 46

³ Only for Estate.⁴ MOExtended tyres (tyres featuring run-flat characteristics) only in combination with an active tyre pressure loss warning system or tyre pressure monitor.⁵ Use of snow chains not permitted. Observe the notes under "Snow chains".⁶ Only in combination with AIRMATIC (code 489), DIRECT CONTROL suspension (code 677) or Sports package (code 950).⁷ Not in combination with trailer tow hitch (code 550) or folding bench seat (code 844) (Estate).⁸ Observe notes on "Large wheels" under "General notes" in "Wheel and tyre combination".² Only for Saloon.

R17

Tyres	Light-alloy wheels
BA: 245/45 R17 95 H M+S  ²	BA: 8.0 J x 17 H2 ET 48
BA: 245/45 R17 99 H XL M+S  ³	BA: 8.0 J x 17 H2 ET 48
BA: 245/45 R17 99 H XL M+S  MOExtended ⁴	BA: 8.0 J x 17 H2 ET 48
BA: 245/45 R17 95 H M+S  ²	BA: 8.5 J x 17 H2 ET 48
BA: 245/45 R17 99 H XL M+S  ³	BA: 8.5 J x 17 H2 ET 48
BA: 245/45 R17 99 H XL M+S  MOExtended ⁴	BA: 8.5 J x 17 H2 ET 48

R18

Tyres	Light-alloy wheels
BA: 245/40 R18 97 H XL M+S 	BA: 8.5 J x 18 H2 ET 48

E 220 BlueTEC

Summer tyres

R16⁹

Tyres	Light-alloy wheels
BA: 225/55 R16 95 W ²	BA: 7.5 J x 16 H2 ET 45.5
BA: 225/55 R16 99 W XL ³	BA: 7.5 J x 16 H2 ET 45.5
BA: 225/55 R16 99 Y XL ³	BA: 7.5 J x 16 H2 ET 45.5
BA: 225/55 R16 95 W ²	BA: 8.0 J x 16 H2 ET 46
BA: 225/55 R16 99 W XL ³	BA: 8.0 J x 16 H2 ET 46
BA: 225/55 R16 99 Y XL ³	BA: 8.0 J x 16 H2 ET 46

² Only for Saloon.

³ Only for Estate.

⁴ MOExtended tyres (tyres featuring run-flat characteristics) only in combination with an active tyre pressure loss warning system or tyre pressure monitor.

⁹ Not in combination with Sports package (code 950) or Exterior Sports package (code P96).

R17

Tyres	Light-alloy wheels
BA: 245/45 R17 95 W ²	BA: 8.0 J x 17 H2 ET 48
BA: 245/45 R17 99 Y XL ³	BA: 8.0 J x 17 H2 ET 48
BA: 245/45 R17 99 Y XL MOExtended ⁴	BA: 8.0 J x 17 H2 ET 48
BA: 245/45 R17 95 W ²	BA: 8.5 J x 17 H2 ET 48
BA: 245/45 R17 99 Y XL ³	BA: 8.5 J x 17 H2 ET 48
BA: 245/45 R17 99 Y XL MOExtended ⁴	BA: 8.5 J x 17 H2 ET 48

R18



Tyres	Light-alloy wheels
BA: 245/40 R18 97 Y XL ³	BA: 8.5 J x 18 H2 ET 48
FA: 245/40 R18 97 Y XL	FA: 8.5 J x 18 H2 ET 48
RA: 265/35 R18 97 Y XL ⁵	RA: 9.0 J x 18 H2 ET 54

R19

Tyres	Light-alloy wheels
FA: 245/35 R19 93 Y XL ^{6,7,8}	FA: 8.5 J x 19 H2 ET 48
RA: 275/30 R19 96 Y XL ^{5,6,7,8}	RA: 9.5 J x 19 H2 ET 48

Winter tyres

R16⁹

Tyres	Light-alloy wheels
BA: 225/55 R16 95 H M+S  ²	BA: 7.5 J x 16 H2 ET 45.5
BA: 225/55 R16 99 H XL M+S  ³	BA: 7.5 J x 16 H2 ET 45.5

² Only for Saloon.

³ Only for Estate.

⁴ MOExtended tyres (tyres featuring run-flat characteristics) only in combination with an active tyre pressure loss warning system or tyre pressure monitor.



⁵ Use of snow chains not permitted. Observe the notes under "Snow chains".

⁶ Only in combination with AIRMATIC (code 489), DIRECT CONTROL suspension (code 677) or Sports package (code 950).







⁷ Not in combination with trailer tow hitch (code 550) or folding bench seat (code 844) (Estate).

⁸ Observe notes on "Large wheels" under "General notes" in "Wheel and tyre combination".

⁹ Not in combination with Sports package (code 950) or Exterior Sports package (code P96).

Tyres	Light-alloy wheels
BA: 225/55 R16 95 H M+S  ²	BA: 8.0 J x 16 H2 ET 46
BA: 225/55 R16 99 H XL M+S  ³	BA: 8.0 J x 16 H2 ET 46

R17

Tyres	Light-alloy wheels
BA: 245/45 R17 95 H M+S  ²	BA: 8.0 J x 17 H2 ET 48
BA: 245/45 R17 99 H XL M+S  ³	BA: 8.0 J x 17 H2 ET 48
BA: 245/45 R17 99 H XL M+S  MOExtended ⁴	BA: 8.0 J x 17 H2 ET 48
BA: 245/45 R17 95 H M+S  ²	BA: 8.5 J x 17 H2 ET 48
BA: 245/45 R17 99 H XL M+S  ³	BA: 8.5 J x 17 H2 ET 48
BA: 245/45 R17 99 H XL M+S  MOExtended ⁴	BA: 8.5 J x 17 H2 ET 48

R18

Tyres	Light-alloy wheels
BA: 245/40 R18 97 H XL M+S 	BA: 8.5 J x 18 H2 ET 48

E 220 CDI

Summer tyres

R16

Tyres	Light-alloy wheels
BA: 205/60 R16 92 W ²	BA: 7.0 J x 16 H2 ET 38
BA: 225/55 R16 95 W ²	BA: 7.5 J x 16 H2 ET 45.5
BA: 225/55 R16 99 W XL ³	BA: 7.5 J x 16 H2 ET 45.5
BA: 225/55 R16 99 Y XL ³	BA: 7.5 J x 16 H2 ET 45.5
BA: 225/55 R16 95 W ²	BA: 8.0 J x 16 H2 ET 46

² Only for Saloon.

³ Only for Estate.

⁴ MOExtended tyres (tyres featuring run-flat characteristics) only in combination with an active tyre pressure loss warning system or tyre pressure monitor.

Tyres	Light-alloy wheels
BA: 225/55 R16 99 W XL ³	BA: 8.0 J x 16 H2 ET 46
BA: 225/55 R16 99 Y XL ³	BA: 8.0 J x 16 H2 ET 46

R17

Tyres	Light-alloy wheels
BA: 245/45 R17 95 W ²	BA: 8.0 J x 17 H2 ET 48
BA: 245/45 R17 99 Y XL ³	BA: 8.0 J x 17 H2 ET 48
BA: 245/45 R17 99 Y XL MOExtended ⁴	BA: 8.0 J x 17 H2 ET 48
BA: 245/45 R17 95 W ²	BA: 8.5 J x 17 H2 ET 48
BA: 245/45 R17 99 Y XL ³	BA: 8.5 J x 17 H2 ET 48
BA: 245/45 R17 99 Y XL MOExtended ⁴	BA: 8.5 J x 17 H2 ET 48

R18

Tyres	Light-alloy wheels
BA: 245/40 R18 97 Y XL ³	BA: 8.5 J x 18 H2 ET 48
FA: 245/40 R18 97 Y XL	FA: 8.5 J x 18 H2 ET 48
RA: 265/35 R18 97 Y XL ⁵	RA: 9.0 J x 18 H2 ET 54

R19

Tyres	Light-alloy wheels
FA: 245/35 R19 93 Y XL ^{6, 7, 8}	FA: 8.5 J x 19 H2 ET 48
RA: 275/30 R19 96 Y XL ^{5, 6, 7, 8}	RA: 9.5 J x 19 H2 ET 48

³ Only for Estate.

² Only for Saloon.

⁴ MOExtended tyres (tyres featuring run-flat characteristics) only in combination with an active tyre pressure loss warning system or tyre pressure monitor.

⁵ Use of snow chains not permitted. Observe the notes under "Snow chains".





⁶ Only in combination with AIRMATIC (code 489), DIRECT CONTROL suspension (code 677) or Sports package (code 950).

⁷ Not in combination with trailer tow hitch (code 550) or folding bench seat (code 844) (Estate).







⁸ Observe notes on "Large wheels" under "General notes" in "Wheel and tyre combination".

Winter tyres

R16

Tyres	Light-alloy wheels
BA: 205/60 R16 92 H M+S  ²	BA: 7.0 J x 16 H2 ET 38
BA: 225/55 R16 95 H M+S  ²	BA: 7.5 J x 16 H2 ET 45.5
BA: 225/55 R16 99 H XL M+S  ³	BA: 7.5 J x 16 H2 ET 45.5
BA: 225/55 R16 95 H M+S  ²	BA: 8.0 J x 16 H2 ET 46
BA: 225/55 R16 99 H XL M+S  ³	BA: 8.0 J x 16 H2 ET 46

R17

Tyres	Light-alloy wheels
BA: 245/45 R17 95 H M+S  ²	BA: 8.0 J x 17 H2 ET 48
BA: 245/45 R17 99 H XL M+S  ³	BA: 8.0 J x 17 H2 ET 48
BA: 245/45 R17 99 H XL M+S  MOExtended ⁴	BA: 8.0 J x 17 H2 ET 48
BA: 245/45 R17 95 H M+S  ²	BA: 8.5 J x 17 H2 ET 48
BA: 245/45 R17 99 H XL M+S  ³	BA: 8.5 J x 17 H2 ET 48
BA: 245/45 R17 99 H XL M+S  MOExtended ⁴	BA: 8.5 J x 17 H2 ET 48

R18

Tyres	Light-alloy wheels
BA: 245/40 R18 97 H XL M+S 	BA: 8.5 J x 18 H2 ET 48

E 220 CDI BlueEFFICIENCY Edition

Summer tyres

R16

Tyres	Light-alloy wheels
BA: 205/55 R16 91 V	BA: 7.0 J x 16 H2 ET 38

² Only for Saloon.

³ Only for Estate.

⁴ MOExtended tyres (tyres featuring run-flat characteristics) only in combination with an active tyre pressure loss warning system or tyre pressure monitor.

Winter tyres

R16

Tyres	Light-alloy wheels
BA: 205/55 R16 91 H M+S	BA: 7.0 J x 16 H2 ET 38

E 250

Summer tyres

R16

Tyres	Light-alloy wheels
BA: 225/55 R16 95 W ²	BA: 7.5 J x 16 H2 ET 45.5
BA: 225/55 R16 99 W XL ³	BA: 7.5 J x 16 H2 ET 45.5
BA: 225/55 R16 99 Y XL ³	BA: 7.5 J x 16 H2 ET 45.5
BA: 225/55 R16 95 W ²	BA: 8.0 J x 16 H2 ET 46
BA: 225/55 R16 99 W XL ³	BA: 8.0 J x 16 H2 ET 46
BA: 225/55 R16 99 Y XL ³	BA: 8.0 J x 16 H2 ET 46

R17

Tyres	Light-alloy wheels
BA: 245/45 R17 95 W ²	BA: 8.0 J x 17 H2 ET 48
BA: 245/45 R17 99 Y XL ³	BA: 8.0 J x 17 H2 ET 48
BA: 245/45 R17 99 Y XL MOExtended ⁴	BA: 8.0 J x 17 H2 ET 48
BA: 245/45 R17 95 W ²	BA: 8.5 J x 17 H2 ET 48
BA: 245/45 R17 99 Y XL ³	BA: 8.5 J x 17 H2 ET 48
BA: 245/45 R17 99 Y XL MOExtended ⁴	BA: 8.5 J x 17 H2 ET 48

² Only for Saloon.

³ Only for Estate.

⁴ MOExtended tyres (tyres featuring run-flat characteristics) only in combination with an active tyre pressure loss warning system or tyre pressure monitor.

R18







Tyres	Light-alloy wheels
BA: 245/40 R18 97 Y XL ³	BA: 8.5 J x 18 H2 ET 48
FA: 245/40 R18 97 Y XL RA: 265/35 R18 97 Y XL ⁵	FA: 8.5 J x 18 H2 ET 48 RA: 9.0 J x 18 H2 ET 54

Winter tyres

R16

Tyres	Light-alloy wheels
BA: 225/55 R16 95 H M+S  ²	BA: 7.5 J x 16 H2 ET 45.5
BA: 225/55 R16 99 H XL M+S  ³	BA: 7.5 J x 16 H2 ET 45.5
BA: 225/55 R16 95 H M+S  ²	BA: 8.0 J x 16 H2 ET 46
BA: 225/55 R16 99 H XL M+S  ³	BA: 8.0 J x 16 H2 ET 46

R17

Tyres	Light-alloy wheels
BA: 245/45 R17 95 H M+S  ²	BA: 8.0 J x 17 H2 ET 48
BA: 245/45 R17 99 H XL M+S  ³	BA: 8.0 J x 17 H2 ET 48
BA: 245/45 R17 99 H XL M+S  MOExtended ⁴	BA: 8.0 J x 17 H2 ET 48
BA: 245/45 R17 95 H M+S  ²	BA: 8.5 J x 17 H2 ET 48
BA: 245/45 R17 99 H XL M+S  ³	BA: 8.5 J x 17 H2 ET 48
BA: 245/45 R17 99 H XL M+S  MOExtended ⁴	BA: 8.5 J x 17 H2 ET 48

R18

Tyres	Light-alloy wheels
BA: 245/40 R18 97 H XL M+S 	BA: 8.5 J x 18 H2 ET 48

³ Only for Estate.

⁵ Use of snow chains not permitted. Observe the notes under "Snow chains".

² Only for Saloon.

⁴ MOExtended tyres (tyres featuring run-flat characteristics) only in combination with an active tyre pressure loss warning system or tyre pressure monitor.

E 250 CDI

Summer tyres

R16

Tyres	Light-alloy wheels
BA: 225/55 R16 95 W ²	BA: 7.5 J x 16 H2 ET 45.5
BA: 225/55 R16 99 W XL ³	BA: 7.5 J x 16 H2 ET 45.5
BA: 225/55 R16 99 Y XL ³	BA: 7.5 J x 16 H2 ET 45.5
BA: 225/55 R16 95 W ²	BA: 8.0 J x 16 H2 ET 46
BA: 225/55 R16 99 W XL ³	BA: 8.0 J x 16 H2 ET 46
BA: 225/55 R16 99 Y XL ³	BA: 8.0 J x 16 H2 ET 46

R17

Tyres	Light-alloy wheels
BA: 245/45 R17 95 W ²	BA: 8.0 J x 17 H2 ET 48
BA: 245/45 R17 99 Y XL ³	BA: 8.0 J x 17 H2 ET 48
BA: 245/45 R17 99 Y XL MOExtended ⁴	BA: 8.0 J x 17 H2 ET 48
BA: 245/45 R17 95 W ²	BA: 8.5 J x 17 H2 ET 48
BA: 245/45 R17 99 Y XL ³	BA: 8.5 J x 17 H2 ET 48
BA: 245/45 R17 99 Y XL MOExtended ⁴	BA: 8.5 J x 17 H2 ET 48

R18

Tyres	Light-alloy wheels
BA: 245/40 R18 97 Y XL ³	BA: 8.5 J x 18 H2 ET 48
FA: 245/40 R18 97 Y XL	FA: 8.5 J x 18 H2 ET 48
RA: 265/35 R18 97 Y XL ⁵	RA: 9.0 J x 18 H2 ET 54

² Only for Saloon.

³ Only for Estate.

⁴ MOExtended tyres (tyres featuring run-flat characteristics) only in combination with an active tyre pressure loss warning system or tyre pressure monitor.

⁵ Use of snow chains not permitted. Observe the notes under "Snow chains".

R19







Tyres	Light-alloy wheels
FA: 245/35 R19 93 Y XL ^{6,7,8}	FA: 8.5 J x 19 H2 ET 48
RA: 275/30 R19 96 Y XL ^{5,6,7,8}	RA: 9.5 J x 19 H2 ET 48

Winter tyres

R16

Tyres	Light-alloy wheels
BA: 225/55 R16 95 H M+S  ²	BA: 7.5 J x 16 H2 ET 45.5
BA: 225/55 R16 99 H XL M+S  ³	BA: 7.5 J x 16 H2 ET 45.5
BA: 225/55 R16 95 H M+S  ²	BA: 8.0 J x 16 H2 ET 46
BA: 225/55 R16 99 H XL M+S  ³	BA: 8.0 J x 16 H2 ET 46

R17

Tyres	Light-alloy wheels
BA: 245/45 R17 95 H M+S  ²	BA: 8.0 J x 17 H2 ET 48
BA: 245/45 R17 99 H XL M+S  ³	BA: 8.0 J x 17 H2 ET 48
BA: 245/45 R17 99 H XL M+S  MOExtended ⁴	BA: 8.0 J x 17 H2 ET 48
BA: 245/45 R17 95 H M+S  ²	BA: 8.5 J x 17 H2 ET 48
BA: 245/45 R17 99 H XL M+S  ³	BA: 8.5 J x 17 H2 ET 48
BA: 245/45 R17 99 H XL M+S  MOExtended ⁴	BA: 8.5 J x 17 H2 ET 48

R18

Tyres	Light-alloy wheels
BA: 245/40 R18 97 H XL M+S 	BA: 8.5 J x 18 H2 ET 48

⁶ Only in combination with AIRMATIC (code 489), DIRECT CONTROL suspension (code 677) or Sports package (code 950).

⁷ Not in combination with trailer tow hitch (code 550) or folding bench seat (code 844) (Estate).

⁸ Observe notes on "Large wheels" under "General notes" in "Wheel and tyre combination".

⁵ Use of snow chains not permitted. Observe the notes under "Snow chains".

² Only for Saloon.

³ Only for Estate.

⁴ MOExtended tyres (tyres featuring run-flat characteristics) only in combination with an active tyre pressure loss warning system or tyre pressure monitor.

E 250 CDI 4MATIC

Summer tyres

R17

Tyres	Light-alloy wheels
BA: 245/45 R17 95 W ²	BA: 8.0 J x 17 H2 ET 48
BA: 245/45 R17 99 Y XL ³	BA: 8.0 J x 17 H2 ET 48
BA: 245/45 R17 99 Y XL MOExtended ⁴	BA: 8.0 J x 17 H2 ET 48
BA: 245/45 R17 95 W ²	BA: 8.5 J x 17 H2 ET 48
BA: 245/45 R17 99 Y XL ³	BA: 8.5 J x 17 H2 ET 48
BA: 245/45 R17 99 Y XL MOExtended ⁴	BA: 8.5 J x 17 H2 ET 48

R18



Tyres	Light-alloy wheels
BA: 245/40 R18 97 Y XL	BA: 8.5 J x 18 H2 ET 48

R19²

Tyres	Light-alloy wheels
FA: 245/35 R19 93 Y XL ^{6, 7, 8}	FA: 8.5 J x 19 H2 ET 48
RA: 275/30 R19 96 Y XL ^{5, 6, 7, 8}	RA: 9.5 J x 19 H2 ET 48

Winter tyres

R17

Tyres	Light-alloy wheels
BA: 245/45 R17 95 H M+S  ²	BA: 8.0 J x 17 H2 ET 48
BA: 245/45 R17 99 H XL M+S  ³	BA: 8.0 J x 17 H2 ET 48
BA: 245/45 R17 99 H XL M+S  MOExtended ⁴	BA: 8.0 J x 17 H2 ET 48

² Only for Saloon.

³ Only for Estate.



⁴ MOExtended tyres (tyres featuring run-flat characteristics) only in combination with an active tyre pressure loss warning system or tyre pressure monitor.

⁶ Only in combination with AIRMATIC (code 489), DIRECT CONTROL suspension (code 677) or Sports package (code 950).

⁷ Not in combination with trailer tow hitch (code 550) or folding bench seat (code 844) (Estate).

⁸ Observe notes on "Large wheels" under "General notes" in "Wheel and tyre combination".

⁵ Use of snow chains not permitted. Observe the notes under "Snow chains".

Tyres	Light-alloy wheels
BA: 245/45 R17 95 H M+S  ²	BA: 8.5 J x 17 H2 ET 48
BA: 245/45 R17 99 H XL M+S  ³	BA: 8.5 J x 17 H2 ET 48
BA: 245/45 R17 99 H XL M+S  MOExtended ⁴	BA: 8.5 J x 17 H2 ET 48

R18

Tyres	Light-alloy wheels
BA: 245/40 R18 97 H XL M+S 	BA: 8.5 J x 18 H2 ET 48

E 300

Summer tyres

R16

Tyres	Light-alloy wheels
BA: 225/55 R16 95 W ²	BA: 7.5 J x 16 H2 ET 45.5
BA: 225/55 R16 99 W XL ³	BA: 7.5 J x 16 H2 ET 45.5
BA: 225/55 R16 99 Y XL ³	BA: 7.5 J x 16 H2 ET 45.5
BA: 225/55 R16 95 W ²	BA: 8.0 J x 16 H2 ET 46
BA: 225/55 R16 99 W XL ³	BA: 8.0 J x 16 H2 ET 46
BA: 225/55 R16 99 Y XL ³	BA: 8.0 J x 16 H2 ET 46

R17

Tyres	Light-alloy wheels
BA: 245/45 R17 95 W ²	BA: 8.0 J x 17 H2 ET 48
BA: 245/45 R17 99 Y XL ³	BA: 8.0 J x 17 H2 ET 48
BA: 245/45 R17 99 Y XL MOExtended ⁴	BA: 8.0 J x 17 H2 ET 48
BA: 245/45 R17 95 W ²	BA: 8.5 J x 17 H2 ET 48

² Only for Saloon.

³ Only for Estate.

⁴ MOExtended tyres (tyres featuring run-flat characteristics) only in combination with an active tyre pressure loss warning system or tyre pressure monitor.

Tyres	Light-alloy wheels
BA: 245/45 R17 99 Y XL ³	BA: 8.5 J x 17 H2 ET 48
BA: 245/45 R17 99 Y XL MOExtended ⁴	BA: 8.5 J x 17 H2 ET 48

R18





Tyres	Light-alloy wheels
BA: 245/40 R18 97 Y XL ³	BA: 8.5 J x 18 H2 ET 48
FA: 245/40 R18 97 Y XL	FA: 8.5 J x 18 H2 ET 48
RA: 265/35 R18 97 Y XL ⁵	RA: 9.0 J x 18 H2 ET 54

R19



Tyres	Light-alloy wheels
FA: 245/35 R19 93 Y XL ^{6,7,8}	FA: 8.5 J x 19 H2 ET 48
RA: 275/30 R19 96 Y XL ^{5,6,7,8}	RA: 9.5 J x 19 H2 ET 48

Winter tyres

R16

Tyres	Light-alloy wheels
BA: 225/55 R16 95 H M+S  ²	BA: 7.5 J x 16 H2 ET 45.5
BA: 225/55 R16 99 H XL M+S  ³	BA: 7.5 J x 16 H2 ET 45.5
BA: 225/55 R16 95 H M+S  ²	BA: 8.0 J x 16 H2 ET 46
BA: 225/55 R16 99 H XL M+S  ³	BA: 8.0 J x 16 H2 ET 46

R17

Tyres	Light-alloy wheels
BA: 245/45 R17 95 H M+S  ²	BA: 8.0 J x 17 H2 ET 48
BA: 245/45 R17 99 H XL M+S  ³	BA: 8.0 J x 17 H2 ET 48

³ Only for Estate.

⁴ MOExtended tyres (tyres featuring run-flat characteristics) only in combination with an active tyre pressure loss warning system or tyre pressure monitor.





⁵ Use of snow chains not permitted. Observe the notes under "Snow chains".

⁶ Only in combination with AIRMATIC (code 489), DIRECT CONTROL suspension (code 677) or Sports package (code 950).

⁷ Not in combination with trailer tow hitch (code 550) or folding bench seat (code 844) (Estate).

⁸ Observe notes on "Large wheels" under "General notes" in "Wheel and tyre combination".

² Only for Saloon.

Tyres	Light-alloy wheels
BA: 245/45 R17 99 H XL M+S  MOExtended ⁴	BA: 8.0 J x 17 H2 ET 48
BA: 245/45 R17 95 H M+S  ²	BA: 8.5 J x 17 H2 ET 48
BA: 245/45 R17 99 H XL M+S  ³	BA: 8.5 J x 17 H2 ET 48
BA: 245/45 R17 99 H XL M+S  MOExtended ⁴	BA: 8.5 J x 17 H2 ET 48

R18

Tyres	Light-alloy wheels
BA: 245/40 R18 97 H XL M+S 	BA: 8.5 J x 18 H2 ET 48

E 300 BlueTEC**Summer tyres****R16**

Tyres	Light-alloy wheels
BA: 225/55 R16 95 W ²	BA: 7.5 J x 16 H2 ET 45.5
BA: 225/55 R16 99 W XL ³	BA: 7.5 J x 16 H2 ET 45.5
BA: 225/55 R16 99 Y XL ³	BA: 7.5 J x 16 H2 ET 45.5
BA: 225/55 R16 95 W ²	BA: 8.0 J x 16 H2 ET 46
BA: 225/55 R16 99 W XL ³	BA: 8.0 J x 16 H2 ET 46
BA: 225/55 R16 99 Y XL ³	BA: 8.0 J x 16 H2 ET 46

R17

Tyres	Light-alloy wheels
BA: 245/45 R17 95 W ²	BA: 8.0 J x 17 H2 ET 48
BA: 245/45 R17 99 Y XL ³	BA: 8.0 J x 17 H2 ET 48
BA: 245/45 R17 99 Y XL MOExtended ⁴	BA: 8.0 J x 17 H2 ET 48
BA: 245/45 R17 95 W ²	BA: 8.5 J x 17 H2 ET 48

⁴ MOExtended tyres (tyres featuring run-flat characteristics) only in combination with an active tyre pressure loss warning system or tyre pressure monitor.

² Only for Saloon.

³ Only for Estate.

Tyres	Light-alloy wheels
BA: 245/45 R17 99 Y XL ³	BA: 8.5 J x 17 H2 ET 48
BA: 245/45 R17 99 Y XL MOExtended ⁴	BA: 8.5 J x 17 H2 ET 48

R18

Tyres	Light-alloy wheels
BA: 245/40 R18 97 Y XL ³	BA: 8.5 J x 18 H2 ET 48
FA: 245/40 R18 97 Y XL	FA: 8.5 J x 18 H2 ET 48
RA: 265/35 R18 97 Y XL ⁵	RA: 9.0 J x 18 H2 ET 54

R19



Tyres	Light-alloy wheels
FA: 245/35 R19 93 Y XL ^{6,7,8}	FA: 8.5 J x 19 H2 ET 48
RA: 275/30 R19 96 Y XL ^{5,6,7,8}	RA: 9.5 J x 19 H2 ET 48

Winter tyres

R16

Tyres	Light-alloy wheels
BA: 225/55 R16 95 H M+S  ²	BA: 7.5 J x 16 H2 ET 45.5
BA: 225/55 R16 99 H XL M+S  ³	BA: 7.5 J x 16 H2 ET 45.5
BA: 225/55 R16 95 H M+S  ²	BA: 8.0 J x 16 H2 ET 46
BA: 225/55 R16 99 H XL M+S  ³	BA: 8.0 J x 16 H2 ET 46

R17

Tyres	Light-alloy wheels
BA: 245/45 R17 95 H M+S  ²	BA: 8.0 J x 17 H2 ET 48
BA: 245/45 R17 99 H XL M+S  ³	BA: 8.0 J x 17 H2 ET 48

³ Only for Estate.

⁴ MOExtended tyres (tyres featuring run-flat characteristics) only in combination with an active tyre pressure loss warning system or tyre pressure monitor.





⁵ Use of snow chains not permitted. Observe the notes under "Snow chains".

⁶ Only in combination with AIRMATIC (code 489), DIRECT CONTROL suspension (code 677) or Sports package (code 950).

⁷ Not in combination with trailer tow hitch (code 550) or folding bench seat (code 844) (Estate).

⁸ Observe notes on "Large wheels" under "General notes" in "Wheel and tyre combination".

² Only for Saloon.

Tyres	Light-alloy wheels
BA: 245/45 R17 99 H XL M+S  MOExtended ⁴	BA: 8.0 J x 17 H2 ET 48
BA: 245/45 R17 95 H M+S  ²	BA: 8.5 J x 17 H2 ET 48
BA: 245/45 R17 99 H XL M+S  ³	BA: 8.5 J x 17 H2 ET 48
BA: 245/45 R17 99 H XL M+S  MOExtended ⁴	BA: 8.5 J x 17 H2 ET 48

R18

Tyres	Light-alloy wheels
BA: 245/40 R18 97 H XL M+S 	BA: 8.5 J x 18 H2 ET 48

E 300 4MATIC**Summer tyres****R17**

Tyres	Light-alloy wheels
BA: 245/45 R17 95 W ²	BA: 8.0 J x 17 H2 ET 48
BA: 245/45 R17 99 Y XL ³	BA: 8.0 J x 17 H2 ET 48
BA: 245/45 R17 99 Y XL MOExtended ⁴	BA: 8.0 J x 17 H2 ET 48
BA: 245/45 R17 95 W ²	BA: 8.5 J x 17 H2 ET 48
BA: 245/45 R17 99 Y XL ³	BA: 8.5 J x 17 H2 ET 48
BA: 245/45 R17 99 Y XL MOExtended ⁴	BA: 8.5 J x 17 H2 ET 48

R18

Tyres	Light-alloy wheels
BA: 245/40 R18 97 Y XL	BA: 8.5 J x 18 H2 ET 48

⁴ MOExtended tyres (tyres featuring run-flat characteristics) only in combination with an active tyre pressure loss warning system or tyre pressure monitor.

² Only for Saloon.







³ Only for Estate.

R19²

Tyres	Light-alloy wheels
FA: 245/35 R19 93 Y XL ^{6,7,8}	FA: 8.5 J x 19 H2 ET 48
RA: 275/30 R19 96 Y XL ^{5,6,7,8}	RA: 9.5 J x 19 H2 ET 48

Winter tyres

R17

Tyres	Light-alloy wheels
BA: 245/45 R17 95 H M+S  ²	BA: 8.0 J x 17 H2 ET 48
BA: 245/45 R17 99 H XL M+S  ³	BA: 8.0 J x 17 H2 ET 48
BA: 245/45 R17 99 H XL M+S  MOExtended ⁴	BA: 8.0 J x 17 H2 ET 48
BA: 245/45 R17 95 H M+S  ²	BA: 8.5 J x 17 H2 ET 48
BA: 245/45 R17 99 H XL M+S  ³	BA: 8.5 J x 17 H2 ET 48
BA: 245/45 R17 99 H XL M+S  MOExtended ⁴	BA: 8.5 J x 17 H2 ET 48

R18

Tyres	Light-alloy wheels
BA: 245/40 R18 97 H XL M+S 	BA: 8.5 J x 18 H2 ET 48

² Only for Saloon.

⁶ Only in combination with AIRMATIC (code 489), DIRECT CONTROL suspension (code 677) or Sports package (code 950).

⁷ Not in combination with trailer tow hitch (code 550) or folding bench seat (code 844) (Estate).

⁸ Observe notes on "Large wheels" under "General notes" in "Wheel and tyre combination".

⁵ Use of snow chains not permitted. Observe the notes under "Snow chains".

³ Only for Estate.

⁴ MOExtended tyres (tyres featuring run-flat characteristics) only in combination with an active tyre pressure loss warning system or tyre pressure monitor.

E 350

Summer tyres

R16⁹

Tyres	Light-alloy wheels
BA: 225/55 R16 95 W ²	BA: 7.5 J x 16 H2 ET 45.5
BA: 225/55 R16 99 W XL ³	BA: 7.5 J x 16 H2 ET 45.5
BA: 225/55 R16 99 Y XL ³	BA: 7.5 J x 16 H2 ET 45.5
BA: 225/55 R16 95 W ²	BA: 8.0 J x 16 H2 ET 46
BA: 225/55 R16 99 W XL ³	BA: 8.0 J x 16 H2 ET 46
BA: 225/55 R16 99 Y XL ³	BA: 8.0 J x 16 H2 ET 46

R17

Tyres	Light-alloy wheels
BA: 245/45 R17 95 W ²	BA: 8.0 J x 17 H2 ET 48
BA: 245/45 R17 99 Y XL ³	BA: 8.0 J x 17 H2 ET 48
BA: 245/45 R17 99 Y XL MOExtended ⁴	BA: 8.0 J x 17 H2 ET 48
BA: 245/45 R17 95 W ²	BA: 8.5 J x 17 H2 ET 48
BA: 245/45 R17 99 Y XL ³	BA: 8.5 J x 17 H2 ET 48
BA: 245/45 R17 99 Y XL MOExtended ⁴	BA: 8.5 J x 17 H2 ET 48

R18

Tyres	Light-alloy wheels
BA: 245/40 R18 97 Y XL ³	BA: 8.5 J x 18 H2 ET 48
FA: 245/40 R18 97 Y XL	FA: 8.5 J x 18 H2 ET 48
RA: 265/35 R18 97 Y XL ⁵	RA: 9.0 J x 18 H2 ET 54

⁹ Not in combination with Sports package (code 950) or Exterior Sports package (code P96).

² Only for Saloon.

³ Only for Estate.

⁴ MOExtended tyres (tyres featuring run-flat characteristics) only in combination with an active tyre pressure loss warning system or tyre pressure monitor.



⁵ Use of snow chains not permitted. Observe the notes under "Snow chains".

R19







Tyres	Light-alloy wheels
FA: 245/35 R19 93 Y XL ^{6, 7, 8}	FA: 8.5 J x 19 H2 ET 48
RA: 275/30 R19 96 Y XL ^{5, 6, 7, 8}	RA: 9.5 J x 19 H2 ET 48

Winter tyres

R16⁹

Tyres	Light-alloy wheels
BA: 225/55 R16 95 H M+S  ²	BA: 7.5 J x 16 H2 ET 45.5
BA: 225/55 R16 99 H XL M+S  ³	BA: 7.5 J x 16 H2 ET 45.5
BA: 225/55 R16 95 H M+S  ²	BA: 8.0 J x 16 H2 ET 46
BA: 225/55 R16 99 H XL M+S  ³	BA: 8.0 J x 16 H2 ET 46

R17

Tyres	Light-alloy wheels
BA: 245/45 R17 95 H M+S  ²	BA: 8.0 J x 17 H2 ET 48
BA: 245/45 R17 99 H XL M+S  ³	BA: 8.0 J x 17 H2 ET 48
BA: 245/45 R17 99 H XL M+S  MOExtended ⁴	BA: 8.0 J x 17 H2 ET 48
BA: 245/45 R17 95 H M+S  ²	BA: 8.5 J x 17 H2 ET 48
BA: 245/45 R17 99 H XL M+S  ³	BA: 8.5 J x 17 H2 ET 48
BA: 245/45 R17 99 H XL M+S  MOExtended ⁴	BA: 8.5 J x 17 H2 ET 48

⁶ Only in combination with AIRMATIC (code 489), DIRECT CONTROL suspension (code 677) or Sports package (code 950).

⁷ Not in combination with trailer tow hitch (code 550) or folding bench seat (code 844) (Estate).

⁸ Observe notes on "Large wheels" under "General notes" in "Wheel and tyre combination".

⁵ Use of snow chains not permitted. Observe the notes under "Snow chains".

⁹ Not in combination with Sports package (code 950) or Exterior Sports package (code P96).

² Only for Saloon.

³ Only for Estate.

⁴ MOExtended tyres (tyres featuring run-flat characteristics) only in combination with an active tyre pressure loss warning system or tyre pressure monitor.

R18

Tyres	Light-alloy wheels
BA: 245/40 R18 97 H XL M+S 	BA: 8.5 J x 18 H2 ET 48

E 350 BlueTEC

Summer tyres

R16⁹

Tyres	Light-alloy wheels
BA: 225/55 R16 95 W ²	BA: 7.5 J x 16 H2 ET 45.5
BA: 225/55 R16 99 W XL ³	BA: 7.5 J x 16 H2 ET 45.5
BA: 225/55 R16 99 Y XL ³	BA: 7.5 J x 16 H2 ET 45.5
BA: 225/55 R16 95 W ²	BA: 8.0 J x 16 H2 ET 46
BA: 225/55 R16 99 W XL ³	BA: 8.0 J x 16 H2 ET 46
BA: 225/55 R16 99 Y XL ³	BA: 8.0 J x 16 H2 ET 46

R17

Tyres	Light-alloy wheels
BA: 245/45 R17 95 W ²	BA: 8.0 J x 17 H2 ET 48
BA: 245/45 R17 99 Y XL ³	BA: 8.0 J x 17 H2 ET 48
BA: 245/45 R17 99 Y XL MOExtended ⁴	BA: 8.0 J x 17 H2 ET 48
BA: 245/45 R17 95 W ²	BA: 8.5 J x 17 H2 ET 48
BA: 245/45 R17 99 Y XL ³	BA: 8.5 J x 17 H2 ET 48
BA: 245/45 R17 99 Y XL MOExtended ⁴	BA: 8.5 J x 17 H2 ET 48

⁹ Not in combination with Sports package (code 950) or Exterior Sports package (code P96).

² Only for Saloon.

³ Only for Estate.

⁴ MOExtended tyres (tyres featuring run-flat characteristics) only in combination with an active tyre pressure loss warning system or tyre pressure monitor.

R18





Tyres	Light-alloy wheels
BA: 245/40 R18 97 Y XL ³	BA: 8.5 J x 18 H2 ET 48
FA: 245/40 R18 97 Y XL	FA: 8.5 J x 18 H2 ET 48
RA: 265/35 R18 97 Y XL ⁵	RA: 9.0 J x 18 H2 ET 54

R19





Tyres	Light-alloy wheels
FA: 245/35 R19 93 Y XL ^{6,7,8}	FA: 8.5 J x 19 H2 ET 48
RA: 275/30 R19 96 Y XL ^{5,6,7,8}	RA: 9.5 J x 19 H2 ET 48

Winter tyres

R16⁹

Tyres	Light-alloy wheels
BA: 225/55 R16 95 H M+S  ²	BA: 7.5 J x 16 H2 ET 45.5
BA: 225/55 R16 99 H XL M+S  ³	BA: 7.5 J x 16 H2 ET 45.5
BA: 225/55 R16 95 H M+S  ²	BA: 8.0 J x 16 H2 ET 46
BA: 225/55 R16 99 H XL M+S  ³	BA: 8.0 J x 16 H2 ET 46

R17

Tyres	Light-alloy wheels
BA: 245/45 R17 95 H M+S  ²	BA: 8.0 J x 17 H2 ET 48
BA: 245/45 R17 99 H XL M+S  ³	BA: 8.0 J x 17 H2 ET 48
BA: 245/45 R17 99 H XL M+S  MOExtended ⁴	BA: 8.0 J x 17 H2 ET 48
BA: 245/45 R17 95 H M+S  ²	BA: 8.5 J x 17 H2 ET 48

³ Only for Estate.

⁵ Use of snow chains not permitted. Observe the notes under "Snow chains".

⁶ Only in combination with AIRMATIC (code 489), DIRECT CONTROL suspension (code 677) or Sports package (code 950).



⁷ Not in combination with trailer tow hitch (code 550) or folding bench seat (code 844) (Estate).

⁸ Observe notes on "Large wheels" under "General notes" in "Wheel and tyre combination".

⁹ Not in combination with Sports package (code 950) or Exterior Sports package (code P96).

² Only for Saloon.

⁴ MOExtended tyres (tyres featuring run-flat characteristics) only in combination with an active tyre pressure loss warning system or tyre pressure monitor.

Tyres	Light-alloy wheels
BA: 245/45 R17 99 H XL M+S  ³	BA: 8.5 J x 17 H2 ET 48
BA: 245/45 R17 99 H XL M+S  MOExtended ⁴	BA: 8.5 J x 17 H2 ET 48

R18

Tyres	Light-alloy wheels
BA: 245/40 R18 97 H XL M+S 	BA: 8.5 J x 18 H2 ET 48

E 350 4MATIC**Summer tyres****R17**

Tyres	Light-alloy wheels
BA: 245/45 R17 95 W ²	BA: 8.0 J x 17 H2 ET 48
BA: 245/45 R17 99 Y XL ³	BA: 8.0 J x 17 H2 ET 48
BA: 245/45 R17 99 Y XL MOExtended ⁴	BA: 8.0 J x 17 H2 ET 48
BA: 245/45 R17 95 W ²	BA: 8.5 J x 17 H2 ET 48
BA: 245/45 R17 99 Y XL ³	BA: 8.5 J x 17 H2 ET 48
BA: 245/45 R17 99 Y XL MOExtended ⁴	BA: 8.5 J x 17 H2 ET 48

R18

Tyres	Light-alloy wheels
BA: 245/40 R18 97 Y XL	BA: 8.5 J x 18 H2 ET 48







³ Only for Estate.⁴ MOExtended tyres (tyres featuring run-flat characteristics) only in combination with an active tyre pressure loss warning system or tyre pressure monitor.² Only for Saloon.

R19²

Tyres	Light-alloy wheels
FA: 245/35 R19 93 Y XL ^{6,7,8}	FA: 8.5 J x 19 H2 ET 48
RA: 275/30 R19 96 Y XL ^{5,6,7,8}	RA: 9.5 J x 19 H2 ET 48

Winter tyres

R17

Tyres	Light-alloy wheels
BA: 245/45 R17 95 H M+S  ²	BA: 8.0 J x 17 H2 ET 48
BA: 245/45 R17 99 H XL M+S  ³	BA: 8.0 J x 17 H2 ET 48
BA: 245/45 R17 99 H XL M+S  MOExtended ⁴	BA: 8.0 J x 17 H2 ET 48
BA: 245/45 R17 95 H M+S  ²	BA: 8.5 J x 17 H2 ET 48
BA: 245/45 R17 99 H XL M+S  ³	BA: 8.5 J x 17 H2 ET 48
BA: 245/45 R17 99 H XL M+S  MOExtended ⁴	BA: 8.5 J x 17 H2 ET 48

R18

Tyres	Light-alloy wheels
BA: 245/40 R18 97 H XL M+S 	BA: 8.5 J x 18 H2 ET 48

E 350 BlueTEC 4MATIC

Summer tyres

R17

Tyres	Light-alloy wheels
BA: 245/45 R17 95 W ²	BA: 8.0 J x 17 H2 ET 48
BA: 245/45 R17 99 Y XL ³	BA: 8.0 J x 17 H2 ET 48

² Only for Saloon.⁶ Only in combination with AIRMATIC (code 489), DIRECT CONTROL suspension (code 677) or Sports package (code 950).⁷ Not in combination with trailer tow hitch (code 550) or folding bench seat (code 844) (Estate).⁸ Observe notes on "Large wheels" under "General notes" in "Wheel and tyre combination".⁵ Use of snow chains not permitted. Observe the notes under "Snow chains".³ Only for Estate.⁴ MOExtended tyres (tyres featuring run-flat characteristics) only in combination with an active tyre pressure loss warning system or tyre pressure monitor.

Tyres	Light-alloy wheels
BA: 245/45 R17 99 Y XL MOExtended ⁴	BA: 8.0 J x 17 H2 ET 48
BA: 245/45 R17 95 W ²	BA: 8.5 J x 17 H2 ET 48
BA: 245/45 R17 99 Y XL ³	BA: 8.5 J x 17 H2 ET 48
BA: 245/45 R17 99 Y XL MOExtended ⁴	BA: 8.5 J x 17 H2 ET 48

R18







Tyres	Light-alloy wheels
BA: 245/40 R18 97 Y XL	BA: 8.5 J x 18 H2 ET 48

R19²

Tyres	Light-alloy wheels
FA: 245/35 R19 93 Y XL ^{6,7,8}	FA: 8.5 J x 19 H2 ET 48
RA: 275/30 R19 96 Y XL ^{5,6,7,8}	RA: 9.5 J x 19 H2 ET 48

Winter tyres

R17

Tyres	Light-alloy wheels
BA: 245/45 R17 95 H M+S  ²	BA: 8.0 J x 17 H2 ET 48
BA: 245/45 R17 99 H XL M+S  ³	BA: 8.0 J x 17 H2 ET 48
BA: 245/45 R17 99 H XL M+S  MOExtended ⁴	BA: 8.0 J x 17 H2 ET 48
BA: 245/45 R17 95 H M+S  ²	BA: 8.5 J x 17 H2 ET 48
BA: 245/45 R17 99 H XL M+S  ³	BA: 8.5 J x 17 H2 ET 48
BA: 245/45 R17 99 H XL M+S  MOExtended ⁴	BA: 8.5 J x 17 H2 ET 48

⁴ MOExtended tyres (tyres featuring run-flat characteristics) only in combination with an active tyre pressure loss warning system or tyre pressure monitor.

² Only for Saloon.

³ Only for Estate.

⁶ Only in combination with AIRMATIC (code 489), DIRECT CONTROL suspension (code 677) or Sports package (code 950).

⁷ Not in combination with trailer tow hitch (code 550) or folding bench seat (code 844) (Estate).

⁸ Observe notes on "Large wheels" under "General notes" in "Wheel and tyre combination".

⁵ Use of snow chains not permitted. Observe the notes under "Snow chains".

R18

Tyres	Light-alloy wheels
BA: 245/40 R18 97 H XL M+S 	BA: 8.5 J x 18 H2 ET 48

E 350 CDI

Summer tyres

R16⁹

Tyres	Light-alloy wheels
BA: 225/55 R16 95 W ²	BA: 7.5 J x 16 H2 ET 45.5
BA: 225/55 R16 99 W XL ³	BA: 7.5 J x 16 H2 ET 45.5
BA: 225/55 R16 99 Y XL ³	BA: 7.5 J x 16 H2 ET 45.5
BA: 225/55 R16 95 W ²	BA: 8.0 J x 16 H2 ET 46
BA: 225/55 R16 99 W XL ³	BA: 8.0 J x 16 H2 ET 46
BA: 225/55 R16 99 Y XL ³	BA: 8.0 J x 16 H2 ET 46

R17

Tyres	Light-alloy wheels
BA: 245/45 R17 95 W ²	BA: 8.0 J x 17 H2 ET 48
BA: 245/45 R17 99 Y XL ³	BA: 8.0 J x 17 H2 ET 48
BA: 245/45 R17 99 Y XL MOExtended ⁴	BA: 8.0 J x 17 H2 ET 48
BA: 245/45 R17 95 W ²	BA: 8.5 J x 17 H2 ET 48
BA: 245/45 R17 99 Y XL ³	BA: 8.5 J x 17 H2 ET 48
BA: 245/45 R17 99 Y XL MOExtended ⁴	BA: 8.5 J x 17 H2 ET 48

⁹ Not in combination with Sports package (code 950) or Exterior Sports package (code P96).

² Only for Saloon.

³ Only for Estate.

⁴ MOExtended tyres (tyres featuring run-flat characteristics) only in combination with an active tyre pressure loss warning system or tyre pressure monitor.

R18



Tyres	Light-alloy wheels
BA: 245/40 R18 97 Y XL ³	BA: 8.5 J x 18 H2 ET 48
FA: 245/40 R18 97 Y XL	FA: 8.5 J x 18 H2 ET 48
RA: 265/35 R18 97 Y XL ⁵	RA: 9.0 J x 18 H2 ET 54

R19





Tyres	Light-alloy wheels
FA: 245/35 R19 93 Y XL ^{6,7,8}	FA: 8.5 J x 19 H2 ET 48
RA: 275/30 R19 96 Y XL ^{5,6,7,8}	RA: 9.5 J x 19 H2 ET 48

Winter tyres

R16⁹

Tyres	Light-alloy wheels
BA: 225/55 R16 95 H M+S  ²	BA: 7.5 J x 16 H2 ET 45.5
BA: 225/55 R16 99 H XL M+S  ³	BA: 7.5 J x 16 H2 ET 45.5
BA: 225/55 R16 95 H M+S  ²	BA: 8.0 J x 16 H2 ET 46
BA: 225/55 R16 99 H XL M+S  ³	BA: 8.0 J x 16 H2 ET 46

R17

Tyres	Light-alloy wheels
BA: 245/45 R17 95 H M+S  ²	BA: 8.0 J x 17 H2 ET 48
BA: 245/45 R17 99 H XL M+S  ³	BA: 8.0 J x 17 H2 ET 48
BA: 245/45 R17 99 H XL M+S  MOExtended ⁴	BA: 8.0 J x 17 H2 ET 48
BA: 245/45 R17 95 H M+S  ²	BA: 8.5 J x 17 H2 ET 48

³ Only for Estate.

⁵ Use of snow chains not permitted. Observe the notes under "Snow chains".

⁶ Only in combination with AIRMATIC (code 489), DIRECT CONTROL suspension (code 677) or Sports package (code 950).



⁷ Not in combination with trailer tow hitch (code 550) or folding bench seat (code 844) (Estate).

⁸ Observe notes on "Large wheels" under "General notes" in "Wheel and tyre combination".

⁹ Not in combination with Sports package (code 950) or Exterior Sports package (code P96).

² Only for Saloon.

⁴ MOExtended tyres (tyres featuring run-flat characteristics) only in combination with an active tyre pressure loss warning system or tyre pressure monitor.

Tyres	Light-alloy wheels
BA: 245/45 R17 99 H XL M+S  ³	BA: 8.5 J x 17 H2 ET 48
BA: 245/45 R17 99 H XL M+S  MOExtended ⁴	BA: 8.5 J x 17 H2 ET 48

R18

Tyres	Light-alloy wheels
BA: 245/40 R18 97 H XL M+S 	BA: 8.5 J x 18 H2 ET 48

E 400**Summer tyres****R17**

Tyres	Light-alloy wheels
BA: 245/45 R17 95 W ²	BA: 8.0 J x 17 H2 ET 48
BA: 245/45 R17 99 Y XL ³	BA: 8.0 J x 17 H2 ET 48
BA: 245/45 R17 99 Y XL MOExtended ⁴	BA: 8.0 J x 17 H2 ET 48
BA: 245/45 R17 95 W ²	BA: 8.5 J x 17 H2 ET 48
BA: 245/45 R17 99 Y XL ³	BA: 8.5 J x 17 H2 ET 48
BA: 245/45 R17 99 Y XL MOExtended ⁴	BA: 8.5 J x 17 H2 ET 48

R18

Tyres	Light-alloy wheels
BA: 245/40 R18 97 Y XL ³	BA: 8.5 J x 18 H2 ET 48
FA: 245/40 R18 97 Y XL	FA: 8.5 J x 18 H2 ET 48
RA: 265/35 R18 97 Y XL ⁵	RA: 9.0 J x 18 H2 ET 54

³ Only for Estate.⁴ MOExtended tyres (tyres featuring run-flat characteristics) only in combination with an active tyre pressure loss warning system or tyre pressure monitor.² Only for Saloon.⁵ Use of snow chains not permitted. Observe the notes under "Snow chains".

R19







Tyres	Light-alloy wheels
FA: 245/35 R19 93 Y XL ^{6,7,8}	FA: 8.5 J x 19 H2 ET 48
RA: 275/30 R19 96 Y XL ^{5,6,7,8}	RA: 9.5 J x 19 H2 ET 48

Winter tyres

R16⁹

Tyres	Light-alloy wheels
BA: 225/55 R16 95 H M+S  ²	BA: 7.5 J x 16 H2 ET 45.5
BA: 225/55 R16 99 H XL M+S  ³	BA: 7.5 J x 16 H2 ET 45.5
BA: 225/55 R16 95 H M+S  ²	BA: 8.0 J x 16 H2 ET 46
BA: 225/55 R16 99 H XL M+S  ³	BA: 8.0 J x 16 H2 ET 46

R17

Tyres	Light-alloy wheels
BA: 245/45 R17 95 H M+S  ²	BA: 8.0 J x 17 H2 ET 48
BA: 245/45 R17 99 H XL M+S  ³	BA: 8.0 J x 17 H2 ET 48
BA: 245/45 R17 99 H XL M+S  MOExtended ⁴	BA: 8.0 J x 17 H2 ET 48
BA: 245/45 R17 95 H M+S  ²	BA: 8.5 J x 17 H2 ET 48
BA: 245/45 R17 99 H XL M+S  ³	BA: 8.5 J x 17 H2 ET 48
BA: 245/45 R17 99 H XL M+S  MOExtended ⁴	BA: 8.5 J x 17 H2 ET 48

⁶ Only in combination with AIRMATIC (code 489), DIRECT CONTROL suspension (code 677) or Sports package (code 950).

⁷ Not in combination with trailer tow hitch (code 550) or folding bench seat (code 844) (Estate).

⁸ Observe notes on "Large wheels" under "General notes" in "Wheel and tyre combination".

⁵ Use of snow chains not permitted. Observe the notes under "Snow chains".

⁹ Not in combination with Sports package (code 950) or Exterior Sports package (code P96).

² Only for Saloon.

³ Only for Estate.

⁴ MOExtended tyres (tyres featuring run-flat characteristics) only in combination with an active tyre pressure loss warning system or tyre pressure monitor.

R18

Tyres	Light-alloy wheels
BA: 245/40 R18 97 H XL M+S 	BA: 8.5 J x 18 H2 ET 48

E 400 4MATIC

Summer tyres

R17

Tyres	Light-alloy wheels
BA: 245/45 R17 95 W ²	BA: 8.0 J x 17 H2 ET 48
BA: 245/45 R17 99 Y XL ³	BA: 8.0 J x 17 H2 ET 48
BA: 245/45 R17 99 Y XL MOExtended ⁴	BA: 8.0 J x 17 H2 ET 48
BA: 245/45 R17 95 W ²	BA: 8.5 J x 17 H2 ET 48
BA: 245/45 R17 99 Y XL ³	BA: 8.5 J x 17 H2 ET 48
BA: 245/45 R17 99 Y XL MOExtended ⁴	BA: 8.5 J x 17 H2 ET 48

R18

Tyres	Light-alloy wheels
BA: 245/40 R18 97 Y XL	BA: 8.5 J x 18 H2 ET 48

R19²

Tyres	Light-alloy wheels
FA: 245/35 R19 93 Y XL ^{6, 7, 8}	FA: 8.5 J x 19 H2 ET 48
RA: 275/30 R19 96 Y XL ^{5, 6, 7, 8}	RA: 9.5 J x 19 H2 ET 48

² Only for Saloon.

³ Only for Estate.

⁴ MOExtended tyres (tyres featuring run-flat characteristics) only in combination with an active tyre pressure loss warning system or tyre pressure monitor.

⁶ Only in combination with AIRMATIC (code 489), DIRECT CONTROL suspension (code 677) or Sports package (code 950).







⁷ Not in combination with trailer tow hitch (code 550) or folding bench seat (code 844) (Estate).

⁸ Observe notes on "Large wheels" under "General notes" in "Wheel and tyre combination".

⁵ Use of snow chains not permitted. Observe the notes under "Snow chains".

Winter tyres

R17

Tyres	Light-alloy wheels
BA: 245/45 R17 95 H M+S  ²	BA: 8.0 J x 17 H2 ET 48
BA: 245/45 R17 99 H XL M+S  ³	BA: 8.0 J x 17 H2 ET 48
BA: 245/45 R17 99 H XL M+S  MOExtended ⁴	BA: 8.0 J x 17 H2 ET 48
BA: 245/45 R17 95 H M+S  ²	BA: 8.5 J x 17 H2 ET 48
BA: 245/45 R17 99 H XL M+S  ³	BA: 8.5 J x 17 H2 ET 48
BA: 245/45 R17 99 H XL M+S  MOExtended ⁴	BA: 8.5 J x 17 H2 ET 48

R18

Tyres	Light-alloy wheels
BA: 245/40 R18 97 H XL M+S 	BA: 8.5 J x 18 H2 ET 48

E 500

Summer tyres

R18

Tyres	Light-alloy wheels
BA: 245/40 R18 97 Y XL ³	BA: 8.5 J x 18 H2 ET 48
FA: 245/40 R18 97 Y XL	FA: 8.5 J x 18 H2 ET 48
RA: 265/35 R18 97 Y XL ⁵	RA: 9.0 J x 18 H2 ET 54

² Only for Saloon.

³ Only for Estate.

⁴ MOExtended tyres (tyres featuring run-flat characteristics) only in combination with an active tyre pressure loss warning system or tyre pressure monitor.

⁵ Use of snow chains not permitted. Observe the notes under "Snow chains".

R19

Tyres	Light-alloy wheels
FA: 245/35 R19 93 Y XL ^{6, 7, 8}	FA: 8.5 J x 19 H2 ET 48
RA: 275/30 R19 96 Y XL ^{5, 6, 7, 8}	RA: 9.5 J x 19 H2 ET 48

Winter tyres

R18

Tyres	Light-alloy wheels
BA: 245/40 R18 97 H XL M+S 	BA: 8.5 J x 18 H2 ET 48

E 500 4MATIC

Summer tyres

R18

Tyres	Light-alloy wheels
BA: 245/40 R18 97 Y XL ³	BA: 8.5 J x 18 H2 ET 48

Winter tyres

R18

Tyres	Light-alloy wheels
BA: 245/40 R18 97 H XL M+S 	BA: 8.5 J x 18 H2 ET 48

E 63 AMG

Summer tyres

R18

Tyres	Light-alloy wheels
FA: 255/40 ZR18 (99 Y) XL MO1 ¹⁰	FA: 9.0 J x 18 H2 ET 37
RA: 285/35 ZR18 (101 Y) XL MO1 ^{5, 10}	RA: 9.5 J x 18 H2 ET 52

⁶ Only in combination with AIRMATIC (code 489), DIRECT CONTROL suspension (code 677) or Sports package (code 950).

⁷ Not in combination with trailer tow hitch (code 550) or folding bench seat (code 844) (Estate).

⁸ Observe notes on "Large wheels" under "General notes" in "Wheel and tyre combination".

⁵ Use of snow chains not permitted. Observe the notes under "Snow chains".

³ Only for Estate.



¹⁰ Not in connection with a ceramic brake system.

R19





Tyres	Light-alloy wheels
FA: 255/35 ZR19 (96 Y) XL ⁸	FA: 9.0 J x 19 H2 ET 37
RA: 285/30 ZR19 (98 Y)XL ^{5,8}	RA: 9.5 J x 19 H2 ET 52

Winter tyres

R18

Tyres	Light-alloy wheels
FA: 255/40 R18 99 V XL M+S  ¹⁰	FA: 9.0 J x 18 H2 ET 37
RA: 255/40 R18 99 V XL M+S  ¹⁰	RA: 9.5 J x 18 H2 ET 52

R19

Tyres	Light-alloy wheels
FA: 255/35 R19 96 V XL M+S  ^{8, 11}	FA: 9.0 J x 19 H2 ET 37
RA: 255/35 R19 96 V XL M+S  ^{8, 11, 12}	RA: 9.5 J x 19 H2 ET 52
FA: 255/35 R19 96 V XL M+S  ⁸	FA: 9.0 J x 19 H2 ET 37
RA: 285/30 R19 98 V XL M+S  ^{5, 8}	RA: 9.5 J x 19 H2 ET 52

E 63 AMG S-MODEL

Summer tyres

R18

Tyres	Light-alloy wheels
FA: 255/40 ZR18 (99 Y) XL MO ¹⁰	FA: 9.0 J x 18 H2 ET 37
RA: 285/35 ZR18 (101 Y) XL MO ^{5, 10}	RA: 9.5 J x 18 H2 ET 52

R19

Tyres	Light-alloy wheels
FA: 255/35 ZR19 (96 Y) XL ⁸	FA: 9.0 J x 19 H2 ET 37
RA: 285/30 ZR19 (98 Y)XL ^{5,8}	RA: 9.5 J x 19 H2 ET 52

⁸ Observe notes on "Large wheels" under "General notes" in "Wheel and tyre combination".

⁵ Use of snow chains not permitted. Observe the notes under "Snow chains".



¹⁰ Not in connection with a ceramic brake system.

¹¹ Estate: maximum permissible speed 220 km/h.





¹² Only fine-link snow chains are permitted.

Winter tyres

R18

Tyres	Light-alloy wheels
FA: 255/40 R18 99 V XL M+S  10	FA: 9.0 J x 18 H2 ET 37
RA: 255/40 R18 99 V XL M+S  10	RA: 9.5 J x 18 H2 ET 52

R19

Tyres	Light-alloy wheels
FA: 255/35 R19 96 V XL M+S  8, 11	FA: 9.0 J x 19 H2 ET 37
RA: 255/35 R19 96 V XL M+S  8, 11, 12	RA: 9.5 J x 19 H2 ET 52
FA: 255/35 R19 96 V XL M+S  8	FA: 9.0 J x 19 H2 ET 37
RA: 285/30 R19 98 V XL M+S  5, 8	RA: 9.5 J x 19 H2 ET 52

E 63 AMG 4MATIC





Summer tyres

R19

Tyres	Light-alloy wheels
FA: 255/35 ZR19 (96 Y) XL ⁸	FA: 9.0 J x 19 H2 ET 37
RA: 285/30 ZR19 (98 Y)XL ^{5, 8}	RA: 9.5 J x 19 H2 ET 52

Winter tyres

R19

Tyres	Light-alloy wheels
FA: 255/35 R19 96 V XL M+S  8, 11	FA: 9.0 J x 19 H2 ET 37
RA: 255/35 R19 96 V XL M+S  8, 11, 12	RA: 9.5 J x 19 H2 ET 52
FA: 255/35 R19 96 V XL M+S  8	FA: 9.0 J x 19 H2 ET 37
RA: 285/30 R19 98 V XL M+S  5, 8	RA: 9.5 J x 19 H2 ET 52

¹⁰ Not in connection with a ceramic brake system.

⁸ Observe notes on "Large wheels" under "General notes" in "Wheel and tyre combination".

¹¹ Estate: maximum permissible speed 220 km/h.

¹² Only fine-link snow chains are permitted.

⁵ Use of snow chains not permitted. Observe the notes under "Snow chains".

E 63 AMG S-MODEL 4MATIC





Summer tyres

R19

Tyres	Light-alloy wheels
FA: 255/35 ZR19 (96 Y) XL ⁸	FA: 9.0 J x 19 H2 ET 37
RA: 285/30 ZR19 (98 Y)XL ^{5, 8}	RA: 9.5 J x 19 H2 ET 52

Winter tyres

R19

Tyres	Light-alloy wheels
FA: 255/35 R19 96 V XL M+S  ^{8, 11}	FA: 9.0 J x 19 H2 ET 37
RA: 255/35 R19 96 V XL M+S  ^{8, 11, 12}	RA: 9.5 J x 19 H2 ET 52
FA: 255/35 R19 96 V XL M+S  ⁸	FA: 9.0 J x 19 H2 ET 37
RA: 285/30 R19 98 V XL M+S  ^{5, 8}	RA: 9.5 J x 19 H2 ET 52

Emergency spare wheel

Important safety notes

 WARNING

The wheel/tyre dimensions and the tyre type of the spare wheel/emergency spare wheel and the wheel to be replaced may differ. Fitting a spare wheel/emergency spare wheel may severely impair the driving characteristics. There is a risk of accident.

To prevent hazardous situations:

- Adapt your driving style accordingly and drive carefully.
- Never fit more than one spare wheel/emergency spare wheel if the dimensions are different to those of the wheel being replaced.
- Only use a spare wheel/emergency spare wheel briefly if the dimensions are different to those of the wheel being replaced.

- Do not switch off ESP[®].
- Have the spare wheel/emergency spare wheel in question replaced at the nearest qualified specialist workshop. Make sure that the wheel/tyre dimensions and tyre type are correct.

When using an emergency spare wheel or spare wheel of a different size, you must not exceed the maximum speed of 80 km/h.

Snow chains must not be fitted to emergency spare wheels.

General notes

You should regularly check the pressure of all your tyres, including the emergency spare wheel, particularly prior to long trips, and correct the pressure as necessary (▷ page 407). The applicable value is found on the wheel or under "Technical data" (▷ page 463).

⁸ Observe notes on "Large wheels" under "General notes" in "Wheel and tyre combination".

⁵ Use of snow chains not permitted. Observe the notes under "Snow chains".

¹¹ Estate: maximum permissible speed 220 km/h.

¹² Only fine-link snow chains are permitted.

An emergency spare wheel may also be fitted against the direction of rotation. Observe the time restriction on use as well as the speed limitation specified on the emergency spare wheel.

Replace the tyres after six years at the latest, regardless of wear. This also applies to the emergency spare wheel.

- i** When you are driving with the collapsible emergency spare wheel fitted, the tyre pressure loss warning system or the tyre pressure monitor cannot function reliably. Only restart the tyre pressure loss warning system/tyre pressure monitor when the defective wheel has been replaced with a new wheel.

Vehicles with tyre pressure monitor:

after mounting an emergency spare wheel, the system may still display the tyre pressure of the removed wheel for a few minutes. The value displayed for the mounted emergency spare wheel is not the same as the current tyre pressure of the emergency spare wheel.

Removing the "Minispare" emergency spare wheel/collapsible emergency spare wheel

Opening the stowage well

Saloon: the emergency spare wheel can be found in the stowage well under the boot floor.

- ▶ Lift the boot floor upwards (▷ page 345).

Estate: the emergency spare wheel is located in the stowage well under the luggage compartment floor.

- ▶ **Without a folding bench seat:** lift up the EASY-PACK folding load compartment floor (▷ page 346).
- ▶ **With a folding bench seat:** remove the seat cushions of the folding bench seat (▷ page 121).

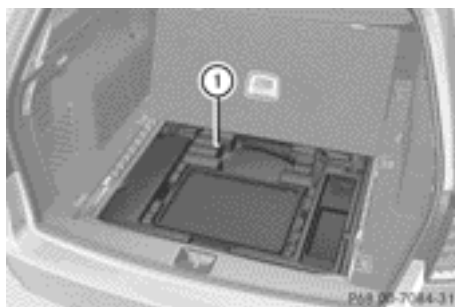

Example: Estate without a folding bench seat

- ▶ **Without a folding bench seat:** remove stowage space ①.
- ▶ **With a folding bench seat:** lift up the luggage compartment floor.

Removing an emergency spare wheel (Estate without a folding bench seat, or Saloon)

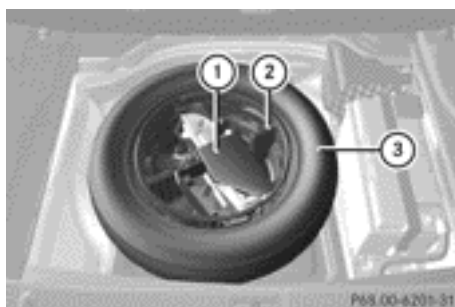

Stowage space (example: Saloon)

- ▶ Remove vehicle tool kit tray ①.
- ▶ Turn stowage tray ② anti-clockwise and remove it.
- ▶ Remove the "Minispare" emergency spare wheel ③ or collapsible emergency spare wheel.

Removing an emergency spare wheel (Estate with folding bench seat)

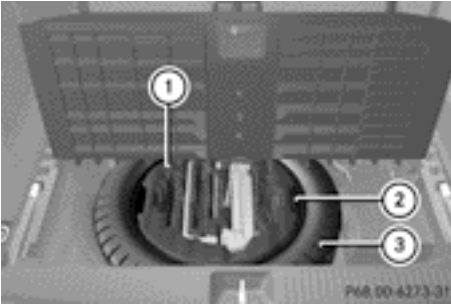

Example: emergency spare wheel

- ▶ Remove vehicle tool kit tray ① by recess ②.
- ▶ Remove the "Minispare" emergency spare wheel or collapsible emergency spare wheel ③.

Observe the instructions and safety notes in the "Fitting a wheel" section (▷ page 414).

Stowing a used collapsible emergency spare wheel

- ❗ Only place the collapsible emergency spare wheel in the vehicle when it is dry. Otherwise, moisture may get into the vehicle.

Take the following steps to stow a used collapsible emergency spare wheel. It will not otherwise fit into the spare wheel well. Mercedes-Benz recommends that you have this work performed at a qualified specialist workshop, e.g. at a Mercedes-Benz Service Centre.

- ▶ Unscrew the valve cap from the valve.
- ▶ Use the back of the valve cap to unscrew the valve insert from the valve and release the air.
- ▶ Fully deflating the tyre may take a few minutes.
- ▶ Screw the valve insert back into the valve.
- ▶ Screw the valve cap back on.

- ▶ Remove the protective film from the vehicle tool kit and put it over the collapsible emergency spare wheel.
- ▶ Stow the collapsible emergency spare wheel in the emergency spare wheel well under the boot.

Inflating the collapsible emergency spare wheel

- ❗ Inflate the collapsible emergency spare wheel using the tyre inflation compressor before lowering the vehicle. The wheel rim could otherwise be damaged.
- ❗ Do not operate the tyre inflation compressor for longer than eight minutes at a time without a break. It may otherwise overheat.

The tyre inflation compressor can be operated again once it has cooled down.

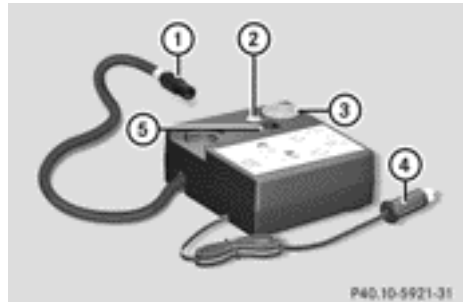

- ▶ Mount the collapsible emergency spare wheel as described (▷ page 413).
The collapsible emergency spare wheel must be mounted before it is inflated.
- ▶ Pull connector ④ and the air hose out of the housing.
- ▶ Remove the cap from the valve on the collapsible emergency spare wheel.
- ▶ Screw union nut ① on the air hose onto the valve.
- ▶ Make sure on/off switch ⑤ of the tyre inflation compressor is set to 0.

- ▶ Insert connector ④ into the cigarette lighter socket or into a 12 V socket in your vehicle.

Observe the notes on the cigarette lighter (▷ page 352). Observe the notes on sockets (▷ page 353).

- ▶ Turn the key to position **1** in the ignition lock (▷ page 177).
- ▶ Press on/off switch ⑤ on the tyre inflation compressor to **I**.
The tyre inflation compressor is switched on. The tyre is inflated. The tyre pressure is shown on pressure gauge ③.

- ▶ Pump the tyre to the specified tyre pressure.

The specified tyre pressure is printed on the yellow label of the emergency spare wheel.

- ▶ When the specified tyre pressure has been reached, press on/off switch ⑤ on the electric air pump to **0**.
The tyre inflation compressor is switched off.

- ▶ Turn the key to position **0** in the ignition lock.

- ▶ If the tyre pressure is higher than the specified pressure, press pressure release button ② until the correct tyre pressure has been reached.

- ▶ Unscrew union nut ① on the air hose from the valve.

- ▶ Screw the valve cap onto the collapsible emergency spare wheel valve again.

- ▶ Stow plug ④ and the air hose in the lower section of the blower housing.

- ▶ Stow the tyre inflation compressor in the vehicle.

Technical data**All vehicles (except AMG vehicles)****"Minispare" emergency spare wheel**

Tyres	Light-alloy wheels
T 155/70 R17 110 M ¹³ Tyre pressure: 420 kPa (4.2 bar/61 psi)	4.0 B x 17 H2 ET 34 ¹³
T 155/60 R18 107 M ¹⁴ Tyre pressure: 420 kPa (4.2 bar/61 psi)	4.5 B x 18 H2 ET 36 ¹⁴

AMG vehicles**Collapsible emergency spare wheel**

Tyres	Light-alloy wheels
175/50- 19 97 P Tyre pressure: 350 kPa (3.5 bar/51 psi)	6.5 B x 19 H2 ET 14

¹³ Not for E 500 and E 500 4MATIC.¹⁴ Not for E 500 and E 500 4MATIC.

Useful information	466
Information on technical data	466
Vehicle electronics	466
Identification plates	468
Service products and capacities	469
Vehicle data	477
Trailer tow hitch	480

Useful information

- i** This Owner's Manual describes all models, series and optional equipment for your vehicle that were available at the time of going to press. National variations are possible. Note that your vehicle may not be equipped with all of the functions described. This is also the case for systems and functions relevant to safety.
- i** Read the information on qualified specialist workshops: (▷ page 26).

Information on technical data

General notes

WARNING

Hybrid vehicles: ensure that you read the "HYBRID" supplement. You could otherwise fail to recognise dangers.

You can find current technical data on the Internet at <http://www.mercedes-benz.com>

- i** The technical data was determined in accordance with EU Directives. All data applies to the vehicle's standard equipment. The data may therefore differ for vehicles with optional equipment. You can obtain further information from a Mercedes-Benz Service Centre.

Information in the printed Owner's Manual

In the printed Owner's Manual you can find information about:

- vehicle data
- boot lid/tailgate opening dimensions
- tank capacity
- engine oil approval and capacity
- AdBlue® filling capacity
- towing a trailer

Vehicle electronics

Tampering with the engine electronics

- !** Only have work carried out on the engine electronics and its associated parts, such as control units, sensors and connector leads, at a qualified specialist workshop. Vehicle components may otherwise wear more quickly and the vehicle's operating permit may be invalidated.

Retrofitting two-way radios and mobile phones (RF transmitters)

WARNING

If RF transmitters are tampered with or not properly retrofitted, the electromagnetic radiation they emit can interfere with the vehicle electronics. This may jeopardise the operational safety of the vehicle. There is a risk of an accident.

You should have all work on electrical and electronic components carried out at a qualified specialist workshop.

WARNING

If you use the RF transmitter in the vehicle in an improper way, its electromagnetic radiation can disrupt vehicle electronics, e.g. if:

- the RF transmitter is not connected to an exterior aerial
- the exterior aerial is fitted incorrectly or is not a low-reflection aerial

This can jeopardise the operating safety of the vehicle. There is a risk of an accident.

Have the low-reflection exterior aerial fitted at a qualified specialist workshop. When operating in the vehicle, always connect the RF transmitter to the low-reflection exterior aerial.

- !** The operating permit may be invalidated if the instructions for installation and use of RF transmitters are not observed.

In particular, the following conditions must be complied with:

- only approved wavebands may be used.
- observe the maximum permissible output in these wavebands.
- only approved aerial positions may be used.

Excessive levels of electromagnetic radiation may cause damage to your health and to the health of others. The use of an exterior aerial takes into consideration the scientific discussion surrounding the possible health risk posed by electromagnetic fields.

Observe the notes on operating mobile phones (▷ page 353).

The following aerial positions may be used for the correct installation of RF transmitters:

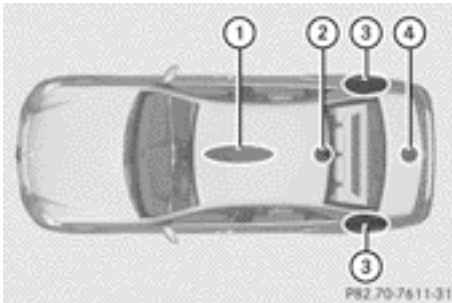

Saloon: approved aerial positions

- ① Front roof area
- ② Rear roof area
- ③ Rear wing
- ④ Boot lid

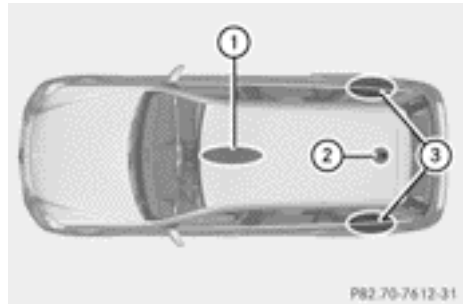

Estate: approved aerial positions

- ① Front roof area
- ② Rear roof area
- ③ Rear wing

i When fitting an aerial on the front roof area of vehicles with a sliding sunroof, observe the sweeping range of the roof.

On vehicles with panorama sliding sunroof, fitting an aerial to the front or rear roof area is not permitted.

On the rear wing, it is recommended that you position the aerial on the side of the vehicle closest to the centre of the road.

Use Technical Specification ISO/TS 21609 (Road Vehicles – "EMC guidelines for fitting aftermarket radio frequency transmitting equipment") when retrofitting RF (radio frequency) transmitters. Comply with the legal requirements for add-on parts.

If your vehicle has fittings for two-way radio equipment, use the power supply or aerial connections intended for use with the basic wiring. Be sure to observe the manufacturer's additional instructions when installing.

Deviations with respect to wavebands, maximum transmission outputs or aerial positions must be approved by Mercedes-Benz.

The maximum transmission output (PEAK) at the base of the aerial must not exceed the following values:

Waveband	Maximum transmission output
Short wave 3 - 54 MHz	100 W
4 m waveband 74 - 78 MHz	30 W
2 m waveband 144 - 174 MHz	50 W
Trunked radio/Tetra 380 - 460 MHz	10 W
70 cm waveband 400 - 460 MHz	35 W
GSM/DCS/PCS 850/900/1800/1900	10 W
UMTS/LTE	10 W

The following can be used in the vehicle without restrictions:

- RF transmitters with a maximum transmission output of up to 100 mW
- Mobile phones (GSM/DCS/PCS/UMTS/LTE)

There are no restrictions when positioning the aerial on the outside of the vehicle for the following wavebands:

- Trunked radio/Tetra
- 70 cm waveband
- GSM/DCS/PCS
- UMTS/LTE

Identification plates

Vehicle identification plate with vehicle identification number (VIN)



- Open the front right-hand door.
You will see vehicle identification plate ①.

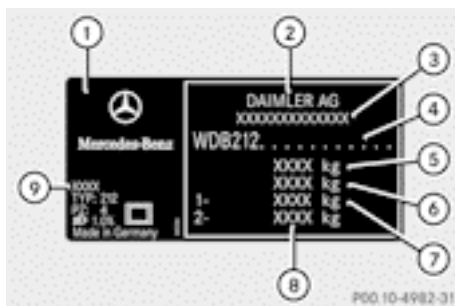

Example: vehicle identification plate

- ① Vehicle identification plate
- ② Vehicle manufacturer (Daimler AG)
- ③ EU type approval number (only for certain countries)
- ④ VIN
- ⑤ Maximum permissible gross vehicle weight (kg)
- ⑥ Maximum permissible mass of vehicle/trailer combination (kg)
- ⑦ Maximum permissible front axle load (kg)
- ⑧ Maximum permissible rear axle load (kg)
- ⑨ Paint code

i The data shown on the vehicle identification plate is example data. This data is different for every vehicle and can deviate from the data shown here. You can find the

data applicable to your vehicle on the vehicle's identification plate.

VIN

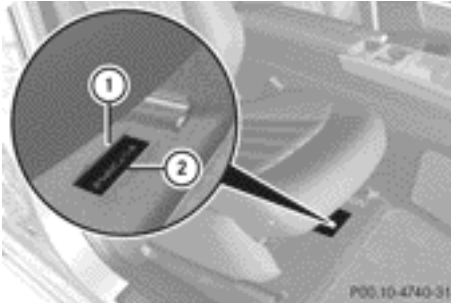

- ▶ Slide the right-hand front seat to its rear-most position.
- ▶ Fold floor covering ① upwards. You will see VIN ②.

The VIN can also be found on the vehicle identification plate (▶ page 468).

Engine number

The engine number is stamped onto the crankcase. You can obtain further information from any qualified specialist workshop.

Service products and capacities

Important safety notes

WARNING

Service product can be poisonous and hazardous to health. There is a risk of injury. Observe the instructions on the respective original container when using, storing and disposing of service products. Always store service products in the sealed original container. Always keep service products out of the reach of children.

Environmental note

Dispose of service products in an environmentally-responsible manner.

Service products include the following:

- Fuels (e.g. petrol, diesel)
- Exhaust gas aftertreatment additives, e.g. AdBlue®
- Lubricants (e.g. engine oil, transmission oil)
- Coolant
- Brake fluid
- Windscreen washer fluid
- Climate control system refrigerant

When handling, storing and disposing of any service products, please observe the relevant regulations.

Components and service products must be matched. Mercedes-Benz recommends that you use products tested and approved by Mercedes-Benz. They are listed in this Mercedes-Benz Owner's Manual in the appropriate section.

You can identify service products approved by Mercedes-Benz by the following inscriptions on the container:

- MB-Freigabe (e.g. MB-Freigabe 229.51)
- MB Approval (e.g. MB Approval 229.51)

Other designations or recommendations indicate a level of quality or a specification in accordance with an MB Sheet Number (e.g. MB 229.5). They have not necessarily been approved by Mercedes-Benz.

Further information can be obtained from any Mercedes-Benz Service Centre or on the Internet at <http://bevo.mercedes-benz.com>.

Fuel

Important safety notes

WARNING

Fuel is highly flammable. If you handle fuel incorrectly, there is a risk of fire and explosion.

You must avoid fire, naked flames, creating sparks and smoking. Switch off the engine and, if applicable, the auxiliary heating before refuelling.

WARNING

Fuels are poisonous and hazardous to health. There is a danger of injury.

Do not swallow fuel or let it come into contact with skin, eyes or clothing. Do not inhale fuel vapours. Keep fuels out of the reach of children.

If you or others come into contact with fuel, observe the following:

- Wash the fuel off any affected areas of skin with water and soap immediately.
- If you get fuel in your eyes, rinse them thoroughly with clean water immediately. Seek immediate medical attention.
- If fuel is swallowed, seek immediate medical attention. Do not induce vomiting.
- Change any clothing that has come into contact with fuel immediately.

Tank capacity

The total capacity of the fuel tank may vary, depending on the vehicle equipment.

Model	Total capacity
E 500 E 500 4MATIC	80.0 l
AMG vehicles	66.0 l or 80.0 l
All other models	59.0 l or 80.0 l

Model	Of which reserve fuel
Models with 59.0 l total capacity	Approx. 8.0 l
Models with 80.0 l total capacity	Approx. 9.0 l
AMG vehicles	Approx. 14.0 l

Petrol (EN 228, E DIN 51626-1)

Fuel grade

 Do not use diesel to refuel vehicles with a petrol engine. Do not switch on the ignition if you accidentally refuel with the wrong fuel. Otherwise, fuel can enter the fuel system. Even small amounts of the wrong fuel could result in damage to the fuel system and the engine. Notify a qualified specialist workshop and have the fuel tank and fuel lines drained completely.

 Only refuel using premium-grade unleaded petrol with at least 95 ROZ/85 MOZ, that conforms to European standard EN 228 or E DIN 51626-1 or an equivalent specification.

Fuel of this specification can contain up to 10 % ethanol.

Fuel that does not conform to EN 228 or E DIN 51626-1 can lead to increased wear and damage the engine and exhaust system.

 Only use the fuel recommended. Operating the vehicle with other fuels can lead to engine failure.

 Do not use the following:

- E85 (petrol with 85% ethanol)
- E100 (100% ethanol)
- M15 (petrol with 15% methanol)
- M30 (petrol with 30% methanol)
- M85 (petrol with 85% methanol)
- M100 (100% methanol)

- Petrol with additives containing metal
- Diesel

Do not mix such fuels with the fuel recommended for your vehicle. Do not use additives. This can otherwise lead to engine damage. This does not include cleaning additives for the removal and prevention of residue build-up. Petrol must only be mixed with additives recommended by Mercedes-Benz; see "Additives". You can obtain further information from any Mercedes-Benz Service Centre.

Usually you will find information about the fuel grade on the pump. If you cannot find the label on the petrol pump, ask the filling station staff.

- i** E10 fuel contains up to 10% bioethanol. Your vehicle is suitable for use with E10 fuel. You can refuel your vehicle using E10 fuel.
- i** As a temporary measure, if the recommended fuel is not available, you may also use unleaded petrol with an octane rating of 91 RON/82 MON. This may reduce engine performance and increase fuel consumption. Avoid driving at full throttle and sudden acceleration. Never refuel using fuel with a lower RON/MON.
- i** In some countries, the available petrol may not be sufficiently low in sulphur. This fuel can temporarily produce unpleasant odours, especially on short journeys. As soon as sulphur-free fuel (sulphur content < 10 ppm) is used for refuelling, the odours are reduced.

Information on refuelling (▷ page 196).

AMG vehicles

- !** Only refuel using super unleaded petrol with at least 98 RON/88 MON that conforms to European standard EN 228 or an equivalent specification. You can otherwise impair engine output or damage the engine.

- !** Premium-grade unleaded petrol with an octane rating of 95 RON/85 MON may be used as a temporary measure if the recommended fuel is not available. This may reduce engine performance and increase fuel consumption. As much as possible, avoid driving at full throttle.

- !** Regular unleaded petrol with an octane rating of 91 RON/82.5 MON may also be used as a temporary measure if the recommended fuel is not available.

Doing so results in noticeably higher fuel consumption, and the engine power output is noticeably reduced. Avoid driving at full throttle.

If only regular unleaded petrol with an octane rating of 91 RON/82.5 MON or lower is available, you must have the vehicle adapted to this fuel at a qualified specialist workshop.

- i** E10 fuel contains up to 10 % bioethanol. Your vehicle is suitable for use with E10 fuel. You can refuel your vehicle using E10 fuel.

E 200, E 250, E 300, E 300 4MATIC, E 350 and E 350 4MATIC

- !** Only refuel using premium-grade sulphur-free unleaded petrol with at least 95 RON/85 MON that conforms to European standard EN 228 or an equivalent specification. You could otherwise impair engine output or damage the emission control system.
- i** In some countries, the available petrol may not be sufficiently low in sulphur. This fuel can temporarily produce unpleasant odours, especially on short journeys. As soon as sulphur-free fuel (sulphur content < 10 ppm) is used for refuelling, the odours are reduced.

Additives

- !** Operating the engine with fuel additives added later can lead to engine failure. Do not mix fuel additives with fuel. This does not include additives for the removal and

prevention of residue build-up. Petrol must only be mixed with additives recommended by Mercedes-Benz. Observe the instructions for use in the product description. More information about recommended additives can be obtained from any Mercedes-Benz Service Centre.

Mercedes-Benz recommends that you use fuel brands that have additives.

The quality of the fuel available in some countries may not be sufficient. Residue could build up as a result. In such cases, and in consultation with a Mercedes-Benz Service Centre, the petrol may be mixed with the cleaning additive recommended by Mercedes-Benz (part no. A0009892545 12). You must observe the notes and mixing ratios specified on the container.

Diesel (EN 590)

Fuel grade

WARNING

If you mix diesel fuel with petrol, the flash point of this fuel mixture is lower than that of pure diesel fuel. When the engine is running, components in the exhaust system may overheat unnoticed. There is a risk of fire.

Never refuel with petrol. Never add petrol to diesel fuel.

! When refuelling, only use diesel fuel that conforms to the European standard EN 590 or is of equivalent quality. Fuel that does not conform to EN 590 can lead to increased wear as well as damage to the engine and exhaust system.

! Do not use the following:

- marine diesel
- heating oil
- bio-diesel
- vegetable oil
- petrol
- paraffin
- kerosene

Do not mix such fuels with diesel fuel and do not use any special additives. This can otherwise lead to engine damage.

! **Vehicles with diesel particle filters:** in countries outside the EU, only use low sulphur Euro diesel with a sulphur content of under 50 ppm. Otherwise, the emission control system could be damaged.

! **Vehicles without a diesel particle filter:** in countries where only diesel fuel with a high sulphur content is available, you will need to carry out your vehicle's oil change at shorter intervals. More information about the interval for oil change can be obtained from any qualified specialist workshop.

Usually you will find information about the fuel grade on the pump. If you cannot find the label on the petrol pump, ask the filling station staff.

Information on refuelling (▷ page 196).

Low outside temperatures

In winter months, diesel fuel with an improved cold flow quality is available. In Europe, the EN 590 standard defines various climate-dependent temperature categories. Malfunctions can be avoided by refuelling with diesel fuel that corresponds to the climatic specifications outlined in EN 590. At unusually low outside temperatures, it is possible that the flow characteristics of the diesel fuel could be insufficient. Accordingly, diesel fuel from warmer areas may not be suitable for operation in colder climatic conditions.

i Further information on country-specific fuel properties and fuel types with low-temperature resistance can be obtained from oil companies, e.g. at filling stations.

Fuel consumption information

Environmental note

CO₂ (carbon dioxide) is the gas which scientists believe to be principally responsible for global warming (the greenhouse effect). Your

vehicle's CO₂ emissions are directly related to fuel consumption and therefore depend on:

- efficient use of the fuel by the engine
- driving style
- other non-technical factors, such as environmental influences, road conditions or traffic flow

You can minimise your vehicle's CO₂ emissions by driving carefully and having it serviced regularly.

The vehicle will use more fuel than usual in the following situations:

- at very low outside temperatures
- in urban traffic
- on short journeys
- in mountainous terrain
- when towing a trailer

i Only for certain countries: you can find the current consumption and emission values of your vehicle in the COC documents (EU CERTIFICATE OF CONFORMITY). These documents are delivered with your vehicle.

The consumption figures were in each case based on the currently applicable version:

- for vehicles that comply with standards up to and including the EURO 4 standard, in accordance with EU Directive 80/1268/EEC
- for vehicles that comply with or exceed the EURO 5 standard, in accordance with Regulation (EC) No. 715/2007

Deviations from these values may occur under normal operating conditions.

AdBlue®

Important safety notes

Comply with the important safety notes for service products when handling AdBlue® (> page 469).

AdBlue® is a water-soluble fluid for the exhaust gas aftertreatment of diesel engines. It is:

- non-toxic
- colourless and odourless
- non-flammable

If you open the AdBlue® tank, small amounts of ammonia vapour may be released.

Ammonia vapours have a pungent odour and are particularly irritating to the skin, to mucous membranes and to the eyes. You may experience a burning sensation in your eyes, nose and throat. You may also experience coughing and watery eyes.

Do not inhale any ammonia vapours that may be released. Only fill the AdBlue® tank in well-ventilated areas.

Low outside temperatures

AdBlue® freezes at a temperature of approximately -11 °C. The vehicle is delivered from the factory equipped with an AdBlue® pre-heating system. Winter operation can thus be guaranteed even at temperatures below -11 °C.

Additives

! Only use AdBlue® in accordance with ISO 22241. Do not use additives with AdBlue® and do not dilute AdBlue® with water. This may destroy the BlueTEC exhaust gas aftertreatment system.

Purity

! Impurities in AdBlue® (e.g. due to other service products, cleaning agents or dust) lead to:

- increased emission values
- damage to the catalytic converter
- engine damage
- malfunctions in the BlueTEC® exhaust gas aftertreatment system

Assuring the purity of AdBlue® is particularly important with respect to avoiding malfunctions in the BlueTEC exhaust gas aftertreatment system.

If AdBlue® is pumped out of the AdBlue® tank, e.g. during repair work, do not use this fluid to refill the tank. The purity of the fluid can no longer be guaranteed.

Capacities

Missing values were not available at the time of going to print.

Model	Total capacity
E 220 BlueTEC	
E 300 BlueTEC	25.5 l
E 350 BlueTEC	24.5 l
E 350 BlueTEC 4MATIC	

Engine oil

General notes

Comply with the important safety notes for service products when handling engine oil (▷ page 469).

The quality of the engine oil is decisive for the function and service life of an engine. After extensive tests, Mercedes-Benz approves engine oils that correspond to the current technical standard.

Therefore, only Mercedes-Benz approved engine oils may be used in Mercedes-Benz engines.

Further information on tested and approved engine oils can be obtained from any Mercedes-Benz Service Centre. Mercedes-Benz recommends that you have the oil change carried out at a qualified specialist workshop. Mercedes-Benz approval is indicated on the oil container by the inscription "MB Approval" and the corresponding designation, e.g. MB Approval 229.51.

You can call up an overview of approved engine oils on the Internet at: <http://bevo.mercedes-benz.com> by entering the designation, e.g. 229.5.

The table shows which engine oils have been approved for your vehicle.

Petrol engines: in certain countries, different engine oils can be used, provided that the maintenance intervals are reduced. For more information, please contact a qualified specialist workshop. Missing values were not available at the time of going to print.

Petrol engines	MB Approval
AMG vehicles	
All models	229.5
Diesel engines with diesel particle filter	MB Approval
All models	228.51, 229.31, 229.51

Use only SAE 0W-40 or SAE 5W-40 engine oils for AMG vehicles.

i If the engine oils listed in the table are not available, you may add the following engine oils until the next oil change:

- vehicles with a petrol engine: MB Approval 229.1, 229.3 or ACEA A3
- diesel engines: MB Approval 229.1, 229.3, 229.5 or ACEA C3

This must only be added once and the amount must not be greater than 1.0 l.

Capacities

The following values refer to an oil change including the oil filter.

Model	Replacement amount
E 180 E 200 E 250	5.8 l
E 500 E 500 4MATIC E 300 BlueTEC E 350 CDI E 350 BlueTEC E 350 BlueTEC 4MATIC	8.0 l
AMG vehicles	8.5 l
All other models	6.5 l

Additives

! Do not use any additives with the engine oil. This could damage the engine.

Engine oil viscosity

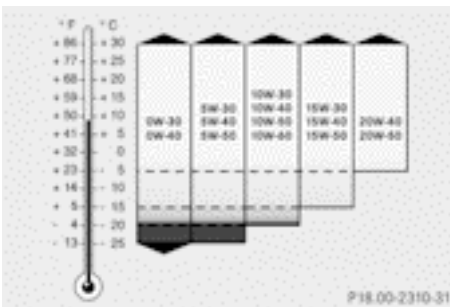

Viscosity describes the flow characteristics of a fluid. If an engine oil has a high viscosity rating, it flows slowly; the lower the viscosity, the faster it flows.

Engine oil selection is based on the respective outside temperatures and in accordance with the SAE classification (viscosity). The table shows you which SAE classifications are to be used. The low-temperature properties of engine oils can be significantly impaired during operation due to, for example, ageing or

soot and fuel accretion. It is therefore strongly recommended to observe regular oil changes using an approved engine oil with the appropriate SAE classification.

Brake fluid

⚠ WARNING

The brake fluid continuously absorbs moisture from the air. This results in the boiling point of the brake fluid lowering. If the boiling point of the brake fluid is too low, vapour pockets may form when the brakes are subjected to a heavy load. This would impair braking efficiency. There is a risk of an accident. Have the brake fluid renewed at the prescribed intervals.

Comply with the important safety notes for service products when handling brake fluid (> page 469).

The brake fluid change intervals can be found in the Service Booklet.

Only use brake fluid approved by Mercedes-Benz according to MB Approval 331.0.

Information about approved brake fluid can be obtained at any qualified specialist workshop or on the Internet at: <http://bevo.mercedes-benz.com>.

i Have the brake fluid regularly replaced at a qualified specialist workshop and the replacement confirmed in the Service Booklet.

Coolant

Important safety notes

⚠ WARNING

If antifreeze comes into contact with hot components in the engine compartment, it may ignite. There is a risk of fire and injury.

Let the engine cool down before you top up the antifreeze. Make sure that antifreeze is not spilled next to the filler neck. Thoroughly

clean the antifreeze from components before starting the engine.

! Only add coolant that has been premixed with the desired antifreeze protection. You could otherwise damage the engine.

Further information on coolants can be found in the Mercedes-Benz Specifications for Service Products, MB Specifications for Service Products 310.1, e.g. on the Internet at <http://bevo.mercedes-benz.com>. Or contact a qualified specialist workshop.

! Always use a suitable coolant mixture, even in countries where high temperatures prevail.

Otherwise, the engine cooling system is not sufficiently protected from corrosion and overheating.

i Have the coolant regularly replaced at a qualified specialist workshop and the replacement confirmed in the Service Booklet.

Comply with the important safety precautions for service products when handling coolant (▷ page 469).

The coolant is a mixture of water and antifreeze/corrosion inhibitor. It is responsible for the following:

- anti-corrosion protection
- antifreeze protection
- raising the boiling point

If antifreeze/corrosion inhibitor is present in the correct concentration, the boiling point of the coolant during operation will be approximately 130 °C.

The antifreeze/corrosion inhibitor concentration in the engine cooling system should:

- be at least 50%. This will protect the engine cooling system against freezing down to approximately -37 °C.
- not exceed 55% (antifreeze protection down to -45 °C). Heat will otherwise not be dissipated as effectively.

If the vehicle has lost coolant, top it up with equal amounts of water and antifreeze/corrosion inhibitor.

Mercedes-Benz recommends an antifreeze/corrosion inhibitor concentrate in accordance with MB Specifications for Service Products 310.1.

i When the vehicle is first delivered, it is filled with a coolant mixture that ensures adequate antifreeze and corrosion protection.

i The coolant is checked at every maintenance interval at a qualified specialist workshop.

Windscreen washer system

Important safety notes

WARNING

Windscreen washer concentrate is highly flammable. If it comes into contact with hot engine components or the exhaust system it could ignite. There is a risk of fire and injury. Make sure that no windscreen washer concentrate is spilled next to the filler neck.

! Do not use distilled or de-ionised water in the washer fluid reservoir. Otherwise, the level sensor may be damaged.

! Only the washer fluids SummerFit and WinterFit can be mixed. Otherwise, the spraying nozzles could become blocked.

Comply with the important safety notes for service products when handling washer fluid (▷ page 469).

At temperatures above freezing:

► Fill the washer fluid reservoir with a mixture of water and washer fluid, e.g. MB SummerFit.

Mix 1 part MB SummerFit to 100 parts water.

At temperatures below freezing:

- Fill the washer fluid reservoir with a mixture of water and washer fluid, e.g. MB WinterFit.

Adapt the mixing ratio to the outside temperature.

- Down to -10 °C: mix 1 part MB WinterFit to 2 parts water.
 - Down to -20 °C: mix 1 part MB WinterFit to 1 part water.
 - Down to -29 °C: mix 2 parts MB WinterFit to 1 part water.
- i** Add washer fluid concentrate, e.g. MB SummerFit or MB WinterFit, to the washer fluid all year round.

Vehicle data

General notes

Please note that for the specified vehicle data:

- the heights specified may vary as a result of:
 - tyres
 - load
 - condition of the suspension
 - optional equipment
- optional equipment reduces the maximum payload
- vehicle-specific weight information can be found on the vehicle identification plate (► page 468)
- only for certain countries: you can find vehicle-specific vehicle data in the COC documents (CERTIFICATE OF CONFORMITY) These documents are delivered with your vehicle.

Dimensions and weights

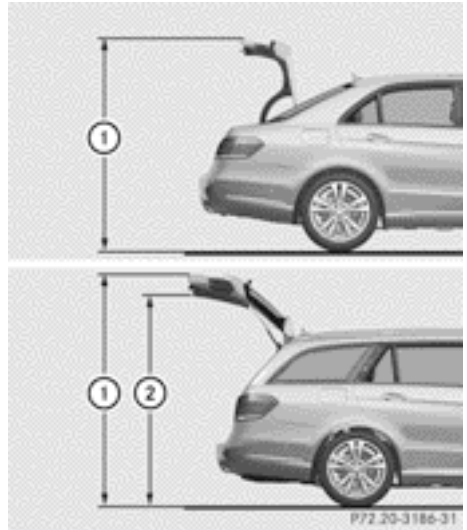

Missing values were not available at the time of going to print.

Model	① Opening height	② Maximum headroom
Saloon	1742 mm - 1763 mm	—
Estate	2046 mm - 2055 mm	1923 mm - 1932 mm
AMG vehicles (Saloon)	1744 mm - 1764 mm	—
AMG vehicles (Estate)	2086 mm - 2106 mm	—

Missing values were not available at the time of going to print.

All models (except AMG vehicles)	
Vehicle length, Saloon	4879 mm
Vehicle length, Estate	4905 mm

All models (except AMG vehicles)	
Vehicle width including exterior mirrors	2071 mm
Vehicle width excluding exterior mirrors	1854 mm
Wheelbase	2874 mm
Maximum roof load	100 kg
Maximum boot load, Saloon	100 kg
Maximum boot load, Estate	

E 180	
Vehicle height	1474 mm

E 200	
Vehicle height, Saloon	1474 mm
Vehicle height, Estate	1507 mm

E 250	
Vehicle height, Saloon	1475 mm
Vehicle height, Estate	1507 mm

E 300	
Vehicle height, Saloon	1475 mm
Vehicle height, Estate	1507 mm

E 300 4MATIC	
Vehicle height, Saloon	1477 mm
Vehicle height, Estate	1509 mm

E 350	
Vehicle height, Saloon	1475 mm
Vehicle height, Estate	1507 mm

E 350 4MATIC	
Vehicle height, Saloon	1477 mm
Vehicle height, Estate	1509 mm

E 400	
Vehicle height, Saloon	1477 mm
Vehicle height, Estate	1509 mm

E 400 4MATIC	
Vehicle height, Saloon	1477 mm
Vehicle height, Estate	1509 mm

E 500	
Vehicle height, Saloon	1458 mm
Vehicle height, Estate	1511 mm

E 500 4MATIC	
Vehicle height, Saloon	1458 mm
Vehicle height, Estate	1511 mm

E 200 CDI	
Vehicle height, Saloon	1474 mm
Vehicle height, Estate	1507 mm

E 220 CDI	
Vehicle height, Saloon	1474 mm
Vehicle height, Estate	1507 mm

E 220 CDI BlueEFFICIENCY Edition	
Vehicle height	1459 mm

E 220 BlueTEC	
Vehicle height	1474 mm

E 250 CDI	
Vehicle height, Saloon	1475 mm
Vehicle height, Estate	1507 mm

E 250 CDI 4MATIC	
Vehicle height, Saloon	1477 mm
Vehicle height, Estate	1509 mm

E 350 CDI	
Vehicle height	1475 mm

E 300 BlueTEC	
Vehicle height, Saloon	1475 mm
Vehicle height, Estate	1507 mm

E 350 BlueTEC	
Vehicle height, Saloon	1475 mm
Vehicle height, Estate	1507 mm

E 350 BlueTEC 4MATIC	
Vehicle height, Saloon	1477 mm
Vehicle height, Estate	1509 mm

All models (only AMG vehicles)	
Vehicle width including exterior mirrors	2071 mm
Vehicle width excluding exterior mirrors	1873 mm
Wheelbase	2874 mm
Maximum roof load	100 kg
Maximum boot load, Saloon	
Maximum boot load, Estate	

E 63 AMG	
Vehicle length, Saloon	4892 mm
Vehicle length, Estate	4904 mm
Vehicle height, Saloon	1450 mm
Vehicle height, Estate	1502 mm

E 63 AMG 4MATIC	
Vehicle length, Saloon	4892 mm
Vehicle length, Estate	4904 mm
Vehicle height, Saloon	1466 mm
Vehicle height, Estate	1522 mm

E 63 AMG S-MODEL	
Vehicle length, Saloon	4900 mm
Vehicle length, Estate	4912 mm
Vehicle height, Saloon	1450 mm
Vehicle height, Estate	1502 mm

E 63 AMG 4MATIC S-MODEL

Vehicle length, Saloon	4900 mm
Vehicle length, Estate	4912 mm
Vehicle height, Saloon	1466 mm
Vehicle height, Estate	1522 mm

ering is 1,253 mm (Saloon) and 1,278 mm (Estate).

Trailer towing is not permissible on the following models:

- E 220 CDI BlueEFFICIENCY Edition
- E 63 AMG
- E 63 AMG S-MODEL
- E 63 AMG 4MATIC
- E 63 AMG S-MODEL 4MATIC

Trailer tow hitch**Mounting dimensions**

! If you have a trailer tow hitch retrofitted, changes to the engine cooling system may be necessary, depending on the vehicle type.

If you have a trailer tow hitch retrofitted, observe the anchorage points on the chassis.

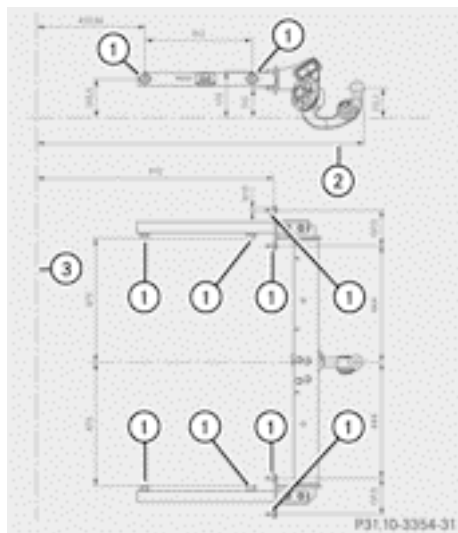

Example: anchorage points for the trailer tow hitch

- ① Anchorage points
- ② Overhang dimension
- ③ Rear axle centre line

For trailer tow hitches fitted at the factory, the overhang dimension including protective cov-

Trailer loads

! Use a drawbar noseweight as close as possible to the maximum permissible noseweight. Do not use a noseweight of less than 50kg, otherwise the trailer may come loose.

Note that the payload and the rear axle load are reduced by the actual payload.

Trailer towing is not permissible on the following models:

- E 220 CDI BlueEFFICIENCY Edition
- E 63 AMG
- E 63 AMG S-MODEL
- E 63 AMG 4MATIC
- E 63 AMG S-MODEL 4MATIC

Missing values for the E 220 BlueTEC model were not available at the time of going to print.

Permissible trailer load, braked (at a minimum gradient-climbing capability of 12% from a standstill)

	Saloon	Saloon
	Manual transmission	Automatic transmission
E 200	1700 kg	1900 kg
E 250	–	1900 kg
E 300	–	2000 kg
E 300 4MATIC	–	2100 kg
E 350	–	2000 kg
E 350 4MATIC	–	2100 kg
E 400	–	2000 kg
E 400 4MATIC	–	2100 kg
E 500	–	2100 kg
E 500 4MATIC	–	2100 kg
E 200 CDI	1900 kg	1900 kg
E 220 CDI	1900 kg	2000 kg
E 250 CDI	1900 kg	2000 kg
E 250 CDI 4MATIC	–	2100 kg
E 350 CDI	–	2100 kg
E 300 BlueTEC	–	2100 kg
E 350 BlueTEC	–	2100 kg

	Saloon	Saloon
	Manual transmission	Automatic transmission
E 350 BlueTEC 4MATIC	-	2100 kg
E 180	-	1700 kg
E 220 BlueTEC		

Permissible trailer load, braked (at a minimum gradient-climbing capability of 12% from a standstill)

	Estate	Estate
	Manual transmission	Automatic transmission
E 200	2100 kg	2100 kg
E 250	-	2100 kg
E 300	-	2100 kg
E 300 4MATIC	-	2100 kg
E 350	-	2100 kg
E 350 4MATIC	-	2100 kg
E 400	-	2100 kg
E 400 4MATIC	-	2100 kg
E 500	-	2100 kg
E 500 4MATIC	-	2100 kg
E 200 CDI	1900 kg	2100 kg
E 220 CDI	1900 kg	2000 kg
E 250 CDI	1900 kg	2100 kg
E 250 CDI 4MATIC	-	2100 kg
E 300 BlueTEC	-	2100 kg
E 350 BlueTEC	-	2100 kg
E 350 BlueTEC 4MATIC	-	2100 kg

	All models (except E 220 BlueTEC)
Permissible trailer load, unbraked	750 kg
Maximum drawbar noseweight (the drawbar nose-weight is not included in the trailer load)	84 kg

The actual noseweight may not, however, be higher than the value which is given:

- on the type plate of the trailer tow hitch and
- on the type plate of the trailer

The lowest weight applies.

You can attach carrier systems, e.g. bicycle racks or load-bearing implements, to the ball coupling. The maximum noseweight of 75 kg applies when using carrier systems on the ball coupling.

Permissible rear axle load when towing a trailer

Trailer towing is not permissible on the following models:

- E 220 CDI BlueEFFICIENCY Edition
- E 63 AMG
- E 63 AMG S-MODEL
- E 63 AMG 4MATIC
- E 63 AMG S-MODEL 4MATIC

Missing values for the E 350 CDI and E 220 BlueTEC models were not available at the time of going to print.

Saloon

	Manual transmission	Automatic transmission
E 200	1305 kg	1315 kg
E 250	–	1330 kg
E 300	–	1355 kg
E 300 4MATIC	–	1370 kg
E 350	–	1355 kg
E 350 4MATIC	–	1370 kg
E 400	–	1375 kg
E 400 4MATIC	–	1370 kg
E 500	–	1380 kg

	Manual transmission	Automatic transmission
E 500 4MATIC	-	1380 kg
E 200 CDI	1340 kg	1330 kg
E 220 CDI	1325 kg	1325 kg
E 250 CDI	1335 kg	1345 kg
E 250 CDI 4MATIC	-	1345 kg
E 350 CDI	-	
E 300 BlueTEC	-	1380 kg
E 350 BlueTEC	-	1380 kg
E 350 BlueTEC 4MATIC	-	1380 kg
E 180	-	1320 kg
E 220 BlueTEC		

Estate

	Manual transmission	Automatic transmission
E 200	1470 kg	1455 kg
E 250	-	1480 kg
E 300	-	1490 kg
E 300 4MATIC	-	1505 kg
E 350	-	1500 kg
E 350 4MATIC	-	1505 kg
E 400	-	1500 kg
E 400 4MATIC	-	1495 kg
E 500	-	1540 kg
E 500 4MATIC	-	1560 kg
E 200 CDI	1485 kg	1475 kg
E 220 CDI	1470 kg	1470 kg
E 250 CDI	1480 kg	1480 kg
E 250 CDI 4MATIC	-	1470 kg

	Manual transmission	Automatic transmission
E 300 BlueTEC	-	1530 kg
E 350 BlueTEC	-	1530 kg
E 350 BlueTEC 4MATIC	-	1540 kg

Publication details

Internet

Further information about Mercedes-Benz vehicles and about Daimler AG can be found on the following websites:

<http://www.mercedes-benz.com>

<http://www.daimler.com>

Editorial office

You are welcome to forward any queries or suggestions you may have regarding this Owner's Manual to the technical documentation team at the following address:

Daimler AG, HPC: CAC, Customer Service,
70546 Stuttgart, Germany

©Daimler AG: not to be reprinted, translated or otherwise reproduced, in whole or in part, without written permission from Daimler AG.

As at 27.11.2012

Nur für internen Gebrauch / For internal use only



2125844900Z102

Order no. 6515 3563 02 Part no. 212 584 49 00 Z102 Edition ÄJ 2013-Mb

Nur für internen Gebrauch / For internal use only