



GL

Owner's Manual



Mercedes-Benz

Nur für internen Gebrauch / For internal use only

Symbols

In this Owner's Manual, you will find the following symbols:

WARNING

Warning notices draw your attention to hazards that may endanger your health or life, or the health or life of others.

Environmental note

Environmental notes provide you with information on environmentally aware actions or disposal.

 Notes on material damage alert you to dangers that could lead to damage to your vehicle.

 This symbol indicates useful instructions or further information that could be helpful to you.

▶ This symbol designates an instruction you must follow.

▶ Several consecutive symbols indicate an instruction with several steps.

(▷ page) This symbol tells you where you can find further information on a topic.

▷▷ This symbol indicates a warning or an instruction that is continued on the next page.

Display This text indicates a message on the multifunction/COMAND display.

Parts of the software in the vehicle are protected by copyright © 2005

The FreeType Project

<http://www.freetype.org>. All rights reserved.

Welcome to the world of Mercedes-Benz

Before you first drive off, read this Owner's Manual carefully and familiarise yourself with your vehicle. For your own safety and a longer vehicle life, follow the instructions and warning notices in this manual. Disregarding them may lead to damage to the vehicle or personal injury.

The equipment or model designation of your vehicle may vary according to:

- model
- order
- country variant
- availability

The illustrations in this manual show a left-hand-drive vehicle. On right-hand-drive vehicles, the layout of components and controls differs accordingly.

Mercedes-Benz is constantly updating its vehicles to the state of the art.

Mercedes-Benz therefore reserves the right to introduce changes in the following areas:

- design
- equipment
- technical features

Therefore, descriptions may vary from those of your own vehicle.

The following are integral components of the vehicle:

- Owner's Manual
- Service Booklet
- equipment-dependent supplements

Keep printed copies of the documents in the vehicle at all times. If you sell the vehicle, always pass the documents on to the new owner.

i You can get to know the important features of your vehicle in the interactive Owner's Manual on the Internet at:

**[http://www.mercedes-benz.de/
betriebsanleitung](http://www.mercedes-benz.de/betriebsanleitung)**

The technical documentation team at Daimler AG wishes you safe and pleasant motoring.



Index	4	At a glance	27
Introduction	23	Safety	39
		Opening and closing	75
		Seats, steering wheel and mirrors	99
		Lights and windscreen wipers	117
		Climate control	135
		Driving and parking	157
		On-board computer and displays	265
		Stowing and features	337
		Maintenance and care	359
		Breakdown assistance	375
		Wheels and tyres	395
		Technical data	419

- 1, 2, 3 ...**
- 12 V socket**
see Socket
- 360° camera**
Function/notes 228
- 360° camera**
Cleaning 370
- 4ETS (Electronic Traction System) ...** 66
- 4MATIC (permanent four-wheel drive)** 250
- A**
- ABS (Anti-lock Braking System)**
Display message 291
Function/notes 61
Important safety notes 61
Warning lamp 327
- Activating/deactivating air-recirculation mode** 146
- Activating/deactivating cooling with air dehumidification** 141
- Active Blind Spot Assist**
Activating/deactivating (on-board computer) 279
Display message 311
Function/notes 242
Towing a trailer 245
- Active Curve System**
Display message 308
Function/notes 213
- Active Driving Assistance package** . 242
- Active Lane Keeping Assist**
Activating/deactivating (on-board computer) 279
Display message 311
Function/notes 246
Towing a trailer 248
- Active light function** 123
- Active Park Assist**
Display message 312
- Active Parking Assist**
Important safety notes 219
Towing a trailer 223
- Active Service System**
see ASSYST PLUS
- ADAPTIVE BRAKE** 68
- Adaptive Brake Assist**
Display message 297
Function/notes 64
- Adaptive brake lamps** 65
- Adaptive Damping System**
see ADS (Adaptive Damping System)
- Adaptive Highbeam Assist**
Display message 303
Function/notes 124
- Adaptive Main-beam Assist**
Switching on/off (on-board computer) 281
- AdBlue®**
Display message 306
Filling capacity 428
Important safety notes 427
Service indicator 366
topping up 178
- AdBlue® service indicator** 366
- Additives (engine oil)** 429
- ADS (Adaptive Damping System)**
Function/notes 212
- Airbags**
Front airbag (driver, front passenger) 43
Important safety guidelines 42
Kneebag 44
Sidebag 44
Triggering 41
Windowbag 45
- Air-conditioning system**
see Climate control
- Air filter (white display message) ...** 306
- AIR FLOW** 143
- AIRMATIC package**
ADS (Adaptive Damping System) ... 212
Function/notes 212
Level control 213
- Air pressure**
see Tyre pressure
- Air vents**
Glove compartment 154
Important safety notes 154
Rear 155
Setting 154
Setting the centre air vents 154
Setting the side air vents 154

- Alarm system**
 - see ATA (Anti-Theft Alarm system)
- Ambient lighting**
 - Setting the brightness (on-board computer) 281
 - Setting the colour (on-board computer) 282
- AMG menu (on-board computer) 286**
- AMG RIDE CONTROL sports suspension 215**
- Anti-glare film 358**
- Anti-lock Braking System**
 - see ABS (Anti-lock Braking System)
- Anti-Theft Alarm system**
 - see ATA (Anti-Theft Alarm system)
- Approach/departure angle 191**
- Aquaplaning 186**
- Ashtray 349**
- Assistance menu (on-board computer) 277**
- ASSYST PLUS**
 - Displaying a service message 365
 - Hiding a service message 365
 - Notes 364
 - Resetting the service interval display 365
 - Service message 364
 - Special service requirements 365
- ATA (Anti-Theft Alarm system)**
 - Activating/deactivating 71
 - Function 71
 - Interior motion sensor 72
 - Switching off the alarm 71
 - Tow-away protection 71
- ATTENTION ASSIST**
 - Activating/deactivating 278
 - Display message 307
 - Function/notes 232
- Audio menu (on-board computer) 274**
- Authorised workshop**
 - see Qualified specialist workshop
- AUTO lights**
 - Display message 303
 - see Lights
- Automatic engine start (ECO start/stop function) 165**
- Automatic engine switch-off (ECO start/stop function) 164**
- Automatic headlamp mode 119**
- Automatic transmission**
 - Accelerator pedal position 170
 - Automatic drive program 171
 - Changing gear 170
 - DIRECT SELECT lever 167
 - Display message 319
 - Drive position (ECO start/stop function) 169
 - Drive program display 168
 - Driving tips 170
 - Emergency running mode 174
 - Engaging drive position 169
 - Engaging neutral 169
 - Engaging park position automatically 168
 - Engaging reverse gear 169
 - Engaging the park position 168
 - Kickdown 170
 - Manual drive program 172
 - Neutral (ECO start/stop function) . 169
 - Overview 167
 - Problem (fault) 174
 - Program selector button 170
 - Pulling away 161
 - Shift ranges 171
 - Starting the engine 161
 - Steering wheel gearshift paddles ... 171
 - Trailer towing 170
 - Transmission position display 168
 - Transmission positions 169
- Automatic transmission emergency running mode 174**
- Auxiliary heating**
 - Activating/deactivating 148
 - Activating/deactivating (on the centre console) 149
 - Display message 321
 - Important safety notes 148
 - Problem (display message) 153
 - Remote control 149
 - Setting 284
 - Setting the departure time 150

- Auxiliary ventilation**
 Activating/deactivating 148
 Activating/deactivating (on the centre console) 149
 Problem (display message) 153
 Remote control 149
- Axle load, permissible (trailer towing)** 433
- B**
- Bag hook** 343
- Ball coupling**
 Folding in 261
 Folding out 259
- BAS (Brake Assist System)** 62
- BAS PLUS (Brake Assist System PLUS)** 62
- Battery (key)**
 Checking 79
 Important safety notes 79
 Replacing 79
- Battery (vehicle)**
 Charging 384
 Display message 305
 Important safety notes 382
 Jump starting 386
 Overview 382
- Belt**
 see Seat belt
- Belt force limiters (activation)** 41
- Belt tensioner**
 Activation 41
 Function 49
- Blind Spot Assist**
 Activating/deactivating 279
 Display message 311
 Notes/function 238
 Trailer towing 240
 see Active Blind Spot Assist
- BlueTEC**
 Topping up AdBlue® 178
- BlueTEC (AdBlue®)** 427
- Bonnet**
 Active bonnet (pedestrian protection) 360
 Closing 361
- Display message 320
 Opening 360
- Boot**
 see Tailgate
- Brake Assist System**
 see BAS (Brake Assist System)
- Brake fluid**
 Display message 296
 Notes 429
- Brake lamps**
 Adaptive 65
 Changing bulbs 131
 Display message 301
- Brakes**
 ABS 61
 Adaptive Brake Assist 64
 BAS 62
 BAS PLUS 62
 Brake fluid (notes) 429
 Display message 291
 Driving tips 184
 High-performance brake system 186
 Important safety notes 184
 Parking brake 182
 Warning lamp 326
- Breakdown**
 see Flat tyre
 see Towing away
- Bulbs**
 see Changing bulbs
- C**
- Calling up a fault**
 see Display messages
- Car**
 see Vehicle
- Care**
 360° camera 370
 Automatic car wash 366
 Carpets 373
 Display 371
 Exhaust pipe 371
 Exterior lighting 369
 Gear or selector lever 372
 High-pressure cleaner 368
 Interior 371
 Matt paintwork 368

Night View Assist Plus	371	Problem (malfunction)	56
Notes	366	Recommendations	58
Paint	368	Suitable positions	56
Plastic trim	372	Top Tether	55
Reversing camera	370	Cigarette lighter	349
Roof lining	373	Cleaning	
Seat belt	373	Mirror turn signal	370
Seat cover	372	Trailer tow hitch	371
Sensors	370	Climate control	
Steering wheel	372	Auxiliary heating/ventilation	148
Trim pieces	372	Controlling automatically	142
Washing by hand	367	Convenience opening/closing (air-recirculation mode)	147
Wheels	369	Cooling with air dehumidification . .	141
Windows	369	Demisting the windows	145
Wiper blades	369	Demisting the windscreen	145
Wooden trim	372	Important safety notes	136
Car key		Indicator lamp	142
see Key		Information on using THERMOTRONIC automatic cli- mate control	141
Car wash (care)	366	Notes on using THERMATIC auto- matic climate control	138
CD player/CD changer(on-board computer)	274	Overview of systems	136
Central locking		Problems with cooling with air dehumidification	142
Automatic locking (on-board com- puter)	283	Problem with the rear window heating	146
Locking/unlocking (key)	77	Rear control panel	139
Centre console		Rear control panel (THERMOTRONIC with additional rear-compartment climate con- trol)	140
Lower section	35	Setting the air distribution	144
Upper section	34	Setting the airflow	144
Changing bulbs		Setting the air vents	154
Brake lamps	131	Setting the climate mode (AIR FLOW)	143
Dipped-beam headlamps	129	Setting the temperature	143
Important safety notes	128	Switching air-recirculation mode on/off	146
Main-beam headlamps	130	Switching on/off	141
Overview of bulb types	129	Switching residual heat on/off	147
Parking lamps (front)	130	Switching the rear window heat- ing on/off	146
Removing/replacing the cover (front wheel arch)	129	Switching the ZONE function on/ off	145
Standing lamps	130		
Child-proof locks			
Important safety notes	59		
Rear doors	60		
Children			
In the vehicle	50		
Restraint systems	50		
Child seat			
Automatic recognition	52		
ISOFIX	53		
On the front-passenger seat	51		

- THERMATIC automatic climate control (2-zone) 137
- THERMOTRONIC (3-zone) automatic climate control 139
- THERMOTRONIC automatic climate control with additional rear-compartment climate control (3-zone) 140
- Coat hooks** 344
- Cockpit**
- Overview 28
 - see Instrument cluster
- COLLISION PREVENTION ASSIST** 63
- COMAND display**
- Cleaning 371
- COMAND Online**
- ON&OFFROAD menu 256
 - see separate operating instructions
- Combination switch** 121
- Constant headlamp mode**
- see Daytime driving lights
- Consumption statistics (on-board computer)** 271
- Convenience closing feature** 90
- Convenience opening/closing (air-recirculation mode)** 147
- Convenience opening feature** 90
- Coolant (engine)**
- Checking the level 363
 - Display message 304
 - Important safety notes 429
 - Temperature (on-board computer) . 286
 - Temperature gauge 268
 - Warning lamp 333
- Cooling**
- see Climate control
- Cornering light function**
- Display message 300
 - Function/notes 123
- Crash-responsive emergency lighting** 128
- Crosswind driving assistance** 68
- Cruise control**
- Activating 194
 - Activation conditions 194
 - Cruise control lever 193
 - Deactivating 195
- Display message 314
 - Driving system 193
 - Important safety notes 193
 - LIM indicator lamp 193
 - Selecting 193
 - Storing and maintaining current speed 194
- Cup holder**
- Centre console 346
 - Important safety notes 346
 - Rear compartment 347
 - Temperature controlled 347
 - Third row of seats 347

D

Dashboard

see Instrument cluster

Dashboard lighting

see Instrument cluster lighting

Data

see Technical data

Daytime driving lights

- Display message 303
- Function/notes 119
- Switching on/off (on-board computer) 280

Dealership

see Qualified specialist workshop

Delayed switch-off

- Exterior lighting (on-board computer) 282
- Interior lighting 282

Diagnostics connection 25

Diesel 426

Diesel particle filter 184

Differential lock (display message) . 308

Digital speedometer 272

Dipped-beam headlamps

- Changing bulbs 129
- Display message 300
- Setting for driving abroad (symmetrical) 118
- Setting for driving on the right/left 281
- Switching on/off 120

DIRECT SELECT lever

see Automatic transmission

- Display message**
 - ASSYST PLUS 364
 - General information 290
 - Hiding (on-board computer) 290
 - KEYLESS-GO 322
- Display messages**
 - Calling up (on-board computer) 290
 - Driving systems 307
 - Engine 304
 - Key 322
 - Lights 300
 - Safety systems 291
 - Tyres 315
 - Vehicle 319
- Distance display (on-board computer)** 277
- Distance warning function**
 - Activating/deactivating 278
 - Function/notes 63
 - Warning lamp 335
- Distance warning signal (warning lamp)** 335
- DISTRONIC PLUS**
 - Activating 200
 - Activation conditions 200
 - Cruise control lever 200
 - Deactivating 204
 - Display message 313
 - Displays in the multifunction display 205
 - Driving tips 206
 - Function/notes 198
 - Important safety notes 198
 - Selecting 200
 - Setting the specified minimum distance 204
 - Warning lamp 335
- Door**
 - Automatic locking (on-board computer) 283
 - Automatic locking (switch) 84
 - Central locking/unlocking (key) 77
 - Control panel 38
 - Display message 320
 - Emergency locking 85
 - Emergency unlocking 84
 - Important safety notes 82
 - Opening (from the inside) 82
 - Power closing 84
- Doors**
 - Overview 82
- Downhill Speed Regulation**
 - see DSR (Downhill Speed Regulation)
- Drive program**
 - Automatic 171
 - Display (DIRECT SELECT lever) 168
 - Manual 172
 - Off-road program (vehicle without the ON&OFFROAD package) 252
 - Off-road programs (vehicle with the ON&OFFROAD package) 253
- Driver's door**
 - see Door
- Drive system**
 - Active Blind Spot Assist 242
- Driving abroad**
 - Service24h 366
 - Symmetrical dipped beam 118
- Driving assistance, crosswind** 68
- Driving in mountainous terrain**
 - Approach/departure angle 191
- Driving off-road**
 - see Off-road driving
- Driving programs**
 - see On-road programs
- Driving safety system**
 - Adaptive Brake Assist 64
 - BAS PLUS (Brake Assist System PLUS) 62
 - COLLISION PREVENTION ASSIST 63
 - Distance warning function 63
 - Electronic Brake-force Distribution 68
 - ESP® (Electronic Stability Program) 66
 - Important safety guidelines 61
- Driving safety systems**
 - 4ETS (Electronic Traction System) ... 66
 - ABS (Anti-lock Braking System) 61
 - ADAPTIVE BRAKE 68
 - Adaptive brake lamps 65
 - BAS (Brake Assist System) 62
 - Overview 60

PRE-SAFE® Brake	68	New brake pads/linings	185
Steering assistant STEER CONTROL	70	Off-road driving	188
Driving system		Off-road fording	186
360° camera	228	Running-in tips	158
Active Lane Keeping Assist	245	Snow chains	399
Active Parking Assist	219	Symmetrical dipped beam	118
ADS	212	Towing a trailer	257
AIRMATIC package	212	Travelling uphill	191
Level control (vehicle with AIR-MATIC package)	213	Tyre ruts	190
On-road programs	248	Wet road surface	185
Driving systems		DSR (Downhill Speed Regulation)	
Active Curve System	213	Display message	309
Active Driving Assistance package	242	Function/notes	251
AMG RIDE CONTROL sports suspension	215	DVD audio	
ATTENTION ASSIST	232	Operating (on-board computer)	274
Blind Spot Assist	238	DVD video	
Cruise control	193	Operating (on-board computer)	275
Display message	307		
Distronic Plus	198		
HOLD function	211		
Lane Keeping Assist	240		
Level control (vehicles with the ON&OFFROAD package)	207		
PARKTRONIC	216		
Reversing camera	223		
Speed Limit Assist	233		
SPEEDTRONIC	196		
Driving tips			
Aquaplaning	186		
Automatic transmission	170		
Brakes	184		
DISTRONIC PLUS	206		
Downhill gradient	185		
Driving abroad	118		
Driving in winter	187		
Driving on flooded roads	186		
Driving on sand	190		
Driving on wet roads	186		
Driving over obstacles	191		
Fuel	184		
General	184		
Icy road surfaces	188		
Limited braking efficiency on salted roads	185		
		E	
		EASY-ENTRY feature	
		Activating/deactivating	285
		Function/notes	111
		EASY-EXIT feature	
		Crash-responsive	112
		Function/notes	111
		Switching on/off	285
		EBD (electronic brake force distribution)	
		Display message	293
		Function/notes	68
		ECO start/stop function	
		Deactivating/activating	163
		General information	163
		Electrical fuses	
		see Fuses	
		Electronic Stability Program	
		see ESP® (Electronic Stability Program)	
		Emergency key	
		Unlocking the driver's door	84
		Emergency key element	
		Function/notes	78
		Locking vehicle	85
		Emergency release	
		Driver's door	84
		Emergency spare wheel	
		Important safety notes	414
		Points to remember	414

- Removing 415
 - Storage location 415
 - Technical data 417
 - Emergency unlocking**
 - Tailgate 88
 - Vehicle 84
 - Engine**
 - Display message 304
 - ECO start/stop function 163
 - Engine number 423
 - Jump-starting 386
 - Running irregularly 166
 - Starting problems 166
 - Starting the engine with the key ... 161
 - Starting with KEYLESS GO 161
 - Stopping 182
 - Tow-starting (vehicle) 391
 - Warning lamp (engine diagnostics) 333
 - Engine electronics**
 - Notes 421
 - Problem (fault) 166
 - Engine oil**
 - Additives 429
 - Checking the oil level 362
 - Checking the oil level using the dipstick 362
 - Display message 305
 - Filling capacity 428
 - Notes about oil grades 428
 - Notes on oil level/consumption ... 362
 - Temperature (on-board computer) . 286
 - Topping up 362
 - Viscosity 429
 - Environmental protection**
 - Returning an end-of-life vehicle 23
 - ESP® (Electronic Stability Program)**
 - 4ETS 66
 - AMG menu (on-board computer) ... 287
 - Deactivating/activating 67
 - Display message 291
 - Function/notes 66
 - Important safety guidelines 66
 - Trailer stabilisation 67
 - Warning lamp 329
 - Exhaust pipe (cleaning instructions) 371**
 - Exterior lighting**
 - see Lights
 - Exterior mirrors**
 - Adjusting 112
 - Anti-dazzle mode (automatic) 114
 - Folding in/out (automatically) 113
 - Folding in/out (electrically) 113
 - Folding in when locking (on-board computer) 285
 - Out of position (troubleshooting) ... 113
 - Parking position 114
 - Resetting 113
 - Storing settings (memory function) 115
- F
- Fault message**
 - see Display messages
 - Filler cap**
 - see Fuel filler flap
 - Fire extinguisher 377**
 - First-aid kit 376**
 - Fitting a wheel**
 - Removing a wheel 407
 - Fitting wheels**
 - Fitting a wheel 408
 - Lowering the vehicle 409
 - Raising the vehicle 406
 - Securing the vehicle against rolling away 405
 - Flat tyre**
 - MOExtended tyres 378
 - Preparing the vehicle 378
 - TIREFIT kit 379
 - Floormat 358**
 - Foglamps (extended range) 124**
 - Folding the rear bench seat forwards/back 341**
 - Fording**
 - Off-road 186
 - On flooded roads 186
 - Frequencies**
 - Garage door opener 354
 - Mobile phone 421
 - Two-way radio 421

- Fuel**
- Additives 425
 - Consumption information 427
 - Consumption statistics 271
 - Displaying the current consumption 272
 - Displaying the range 272
 - Driving tips 184
 - Fuel gauge 30, 267
 - Grade (petrol) 424
 - Important safety notes 423
 - Notes for AMG vehicles 425
 - Problem (malfunction) 177
 - Quality (diesel) 426
 - Refuelling 174
 - Tank content/reserve fuel 424
- Fuel filler flap**
- Opening/closing 175
- Fuel filter (white display message)** . 306
- Fuel level**
- Calling up the range (on-board computer) 272
 - Gauge 30, 267
- Fuel reserve**
- see Fuel
- Fuel tank**
- Capacity 424
 - Problem (malfunction) 177
- Fuses**
- Allocation chart 392
 - Before changing 392
 - Dashboard fuse box 392
 - Fuse box in the engine compartment 392
 - Fuse box under rear bench seat 393
 - Important safety notes 391
- G**
- Garage door opener**
- Clearing the memory 354
 - Frequencies 354
 - Important safety notes 352
 - Opening/closing the garage door .. 354
 - Programming (button in the rear-view mirror) 352
- Gear indicator (on-board computer)** 286
- Gearshift program**
- SETUP (on-board computer) 287
- Genuine Mercedes-Benz parts** 420
- Glove compartment** 339
- H**
- Handbrake**
- see Parking brake
- Hazard warning lamps** 122
- Headlamp**
- Cleaning system (function) 123
 - Cleaning system (notes) 430
- Headlamps**
- Misting up 126
 - Topping up the cleaning system 364
 - see Automatic headlamp mode
- Head restraints**
- Adjusting 102
 - Adjusting (electrically) 103
 - Adjusting (manually) 102
 - Adjusting (rear) 103
 - Fitting/removing (rear) 104
 - Luxury 103
- Heating**
- see Climate control
- High-pressure cleaners** 368
- Hill start assist** 162
- HOLD function**
- Display message 310
 - Function/notes 211
- I**
- Ignition lock**
- see Key positions
- Immobiliser** 71
- Indicator and warning lamps**
- Coolant 333
 - DISTRONIC PLUS 335
 - Engine diagnostics 333
- Indicator lamps**
- Display message 301
 - see Warning and indicator lamps
- Insect protection on the radiator** 362
- Inspection**
- see ASSYST PLUS

- Instrument cluster**
 Overview 30, 267
 Warning and indicator lamps 32, 324
- Instrument cluster lighting** 268
- Intelligent Light System**
 Activating/deactivating 281
 Display message 303
 Overview 123
 Setting the dipped-beam headlamps for driving on the right/left . 281
- Interior lighting** 126
 Automatic control system 127
 Delayed switch-off (on-board computer) 282
 Emergency lighting 128
 Manual control 127
 Overview 126
 Reading lamp 126
 Setting the ambient lighting brightness (on-board computer) 281
 Setting the ambient lighting colour (on-board computer) 282
- Interior motion sensor** 72
- ISOFIX child seat securing system** 53
- J**
- Jack**
 Storage location 377
 Using 406
- Jump start (engine)**
 see Jump starting (engine)
- Jump starting (engine)** 386
- K**
- Key**
 Changing the battery 79
 Checking the battery 79
 Convenience closing feature 91
 Convenience opening feature 90
 Display message 322
 Door central locking/unlocking 77
 Emergency key element 78
 Important safety notes 76
 Loss 81
 Modifying the programming 78
 Overview 76
 Positions (ignition lock) 159
 Problem (malfunction) 81
 Starting the engine 161
- KEYLESS-GO**
 Convenience closing 91
 Display message 322
 Locking 77
 Start/Stop button 159
 Starting the engine 161
 Unlocking 77
- Key positions**
 Key 159
 KEYLESS GO 159
- Kickdown**
 Driving tips 170
 Manual drive program 173
- Kneebag** 44
- L**
- Lamps**
 see Warning and indicator lamps
- Lane Keeping Assist**
 Activating/deactivating 279
 Display message 311
 Function/information 240
 see Active Lane Keeping Assist
- Lap time (RACETIMER)** 287
- Lashing eyelets** 343
- Level control (display message)** 307
- Level control (vehicles with the ON&OFFROAD package)**
 Basic settings 208
 Function/notes 207
 Important safety notes 207
- Level control (vehicle with AIR-MATIC package)**
 Basic settings 213
 Function/notes 213
 Important safety notes 213
- Licence plate lamp (display message)** 302
- Lighting**
 see Lights
- Lights**
 Activating/deactivating the Intelligent Light System 281

- Activating/deactivating the interior lighting delayed switch-off 282
- Active light function 123
- Automatic headlamp mode 119
- Cornering light function 123
- Dipped-beam headlamps 120
- Driving abroad 118
- Foglamps (extended range) 124
- Hazard warning lamps 122
- Headlamp flasher 122
- Light switch 119
- Main-beam headlamps 122
- Motorway mode 124
- Off-road lights 124
- Parking lamps 121
- Rear foglamp 120
- Setting the ambient lighting brightness (on-board computer) 281
- Setting the ambient lighting colour (on-board computer) 282
- Side lamps 120
- Switching Adaptive Highbeam Assist on/off 281
- Switching the daytime driving lights on/off (on-board computer) . 280
- Switching the exterior lighting delayed switch-off on/off (on-board computer) 282
- Switching the surround lighting on/off (on-board computer) 282
- Turn signals 121
- see Changing bulbs
- see Interior lighting
- Light sensor (display message) 303**
- LIM indicator lamp**
- Cruise control 193
- DISTRONIC PLUS 200
- Variable SPEEDTRONIC 196
- Limiting the speed**
- see SPEEDTRONIC
- Loading guidelines 338**
- Locking**
- see Central locking
- Locking (doors)**
- Automatic 84
- Emergency locking 85
- From inside (central locking button) 83
- Locking centrally**
- see Central locking
- Locking verification signal (on-board computer) 283**
- LOW RANGE**
- Display message 309
- Off-road gear 254
- LOW RANGE off-road gear 254**
- Luggage compartment cover**
- Notes/function 344
- Luggage compartment enlargement**
- Important safety notes 341
- Luggage compartment floor**
- opening/closing 344
- stowage well, under 344
- Lumbar support**
- Adjusting (on the seat) 108
- Luxury head restraint 103**

M

- M+S tyres 398**
- Main-beam headlamps**
- Changing bulbs 130
- Display message 302
- Switching Adaptive Highbeam Assist on/off 125
- Switching on/off 122
- Matt finish (cleaning instructions) . . 368**
- Memory card (audio) 274**
- Memory function 115**
- Mercedes-Benz Service Centre**
- see Qualified specialist workshop
- Message memory (on-board computer) 290**
- Messages**
- see Display messages
- Mirror**
- see Vanity mirror (in sun visor)
- Mirrors**
- see Exterior mirrors
- see Rear-view mirror
- Mobile phone**
- Frequencies 421
- Installation 421
- Menu (on-board computer) 275

- Notes/placing in the bracket 351
 - Transmission output (maximum) 421
 - Modifying the programming (key)** 78
 - MOExtended tyres** 378
 - Motorway mode** 124
 - MP3**
 - Operating 274
 - see Separate operating instructions
 - Multifunction display**
 - Function/notes 270
 - Permanent display 280
 - Multifunction steering wheel**
 - Operating the on-board computer . 269
 - Overview 33
- N**
- Navigation**
 - Menu (on-board computer) 272
 - see separate operating instructions
 - Night View Assist Plus**
 - Activating/deactivating 235
 - Cleaning 371
 - Problem (fault) 238
 - Notes on running in a new vehicle** .. 158
- O**
- Occupant safety**
 - Children in the vehicle 50
 - Important safety notes 40
 - Odometer**
 - see Total distance recorder
 - see Trip meter
 - Off-road driving**
 - Checklist after driving off-road 190
 - Checklist before driving off-road 189
 - General information 188
 - Important safety notes 188
 - Travelling uphill 191
 - Off-road lights** 124
 - Off-road program (vehicle without the ON&OFFROAD package)**
 - Function/notes 252
 - Off-road program (vehicle with the ON&OFFROAD package)**
 - Off-road program 1 253
 - Off-road program 2 254
 - Off-road programmes (vehicles with the ON&OFFROAD package)**
 - Displays in the COMAND display ... 256
 - Off-road programs (vehicles with the ON&OFFROAD package)**
 - Function/notes 253
 - Off-road system**
 - 4MATIC 250
 - DSR 251
 - LOW RANGE off-road gear 254
 - Off-road 4ETS 66
 - Off-road ABS 61
 - Off-road ESP® 67
 - Off-road program (vehicle without the ON&OFFROAD package) 252
 - Off-road programs (vehicle with the ON&OFFROAD package) 253
 - Oil**
 - see Engine oil
 - On and Offroad menu (on-board computer)** 286
 - On-board computer**
 - AMG menu 286
 - Assistance menu 277
 - Audio menu 274
 - Convenience submenu 285
 - Displaying a service message 365
 - Display messages 290
 - DISTRONIC PLUS 205
 - Factory setting submenu 286
 - Heating submenu 284
 - Important safety notes 266
 - Instrument cluster submenu 280
 - Light submenu 280
 - Menu overview 271
 - Message memory 290
 - Navigation menu 272
 - On and Offroad menu 286
 - Operating the TV 275
 - Operating video DVD 275
 - Operation 269
 - RACETIMER 287
 - Service menu 279
 - Settings menu 279
 - Standard display 271
 - Telephone menu 275
 - Trip menu 271
 - Vehicle submenu 283

- On-road programs**
 AUTO program 248
 Function/notes 248
 Snow program 249
 SPORT program 249
 Trailer program 250
- Opening and closing the side trim panels** 130
- Operating system**
 see On-board computer
- Outside temperature display** 268
- Overhead control panel** 37
- Override feature**
 Rear side windows 60
- P**
- Paint code** 422
- Paintwork (cleaning instructions)** ... 368
- Panorama sliding sunroof**
 Important safety information 93
 Opening/closing 95
 Opening/closing the roller sun-blind 96
 Problem (malfunction) 97
 Rain closing feature 95
 Resetting 96
- Parking** 181
 Important safety notes 181
 Parking brake 182
 Position of exterior mirror, front-passenger side 114
 Reversing camera 223
 see PARKTRONIC
- Parking aid**
 Active Parking Assist 219
 see Exterior mirrors
 see PARKTRONIC
- Parking brake**
 Display message 294
 Electric parking brake 182
 Warning lamp 332
- Parking lamps**
 Changing bulbs 130
 Display message 302
 Switching on/off 121
- Parking lamps (changing bulbs)** 130
- PARKTRONIC**
 Deactivating/activating 218
 Driving system 216
 Function/notes 216
 Important safety notes 216
 Problem (fault) 219
 Sensor range 216
 Trailer towing 218
 Warning display 217
- PASSENGER AIRBAG OFF warning lamp** 52
- Petrol** 424
- Plastic trim (cleaning instructions)** . 372
- Power closing feature** 84
- Power windows**
 see Side windows
- PRE-SAFE® (preventive occupant safety system)**
 Display message 297
 Operation 45
- PRE-SAFE® Brake**
 Activating/deactivating 278
 Display message 298
 Function/notes 68
 Warning lamp 335
- Product information** 23
- Program selector button** 170
- Protection of the environment**
 General notes 23
- Pulling away**
 Trailer 162
- Pulling away (automatic transmission)** 161
- Q**
- Qualified specialist workshop** 25
- R**
- RACETIMER (on-board computer)** 287
- Radar sensors**
 Overview 433
- Radar sensor system**
 Activating/deactivating 283
 Display message 310
- Radiator cover** 362

- Radio**
 Selecting a station 274
 see separate operating instructions
- radio-controlled devices (fitting)** 358
- Rain closing feature**
 Panorama sliding sunroof 95
 Sliding sunroof 94
- Reading lamp** 126
- Rear compartment**
 Exit/entry position (3rd row of seats) 106
 Setting the air vents 155
- Rear-compartment seat belt status indicator** 49
- Rear foglamp**
 Display message 302
 Switching on/off 120
- Rear seat**
 Adjusting 104
 Display message 320
- Rear-view mirror**
 Anti-dazzle mode (automatic) 114
 Dipping (manual) 112
- Rear window heating**
 Problem (fault) 146
 Switching on/off 146
- Rear window wiper**
 Replacing the wiper blade 133
 Switching on/off 132
- Refuelling**
 Fuel gauge 30, 267
 Important safety notes 174
 Notes for AMG vehicles 425
 Refuelling process 175
 see Fuel
- Remote control**
 Auxiliary heating/ventilation 149
 Changing the batteries (auxiliary heating) 151
 Programming (garage door opener) 352
- Replacing the battery (auxiliary heating remote control)** 151
- Reserve (fuel tank)**
 see Fuel
- Reserve fuel**
 Display message 305
 Warning lamp 333
- Residual heat (climate control)** 147
- Restraint system**
 see SRS (Supplemental Restraint System)
- Rev counter** 268
- Reversing camera**
 Cleaning instructions 370
 Function/notes 223
 Switching on/off 224
- Reversing lamp (display message) ..** 302
- Roller sunblind**
 Panorama sliding sunroof 95
- Roof carrier** 345
- Roof lining and carpets (cleaning instructions)** 373
- Roof load (maximum)** 431
- Route (navigation)**
 see Route guidance (navigation)
- Route guidance (navigation)** 272

S

- Safety**
 Children in the vehicle 50
 Child restraint systems 50
- Safety system**
 see Driving safety system
- Seat belt**
 Adjusting the driver's and front-passenger seat belt 48
 Adjusting the height 48
 Belt force limiter 49
 Belt tensioner 49
 Cleaning 373
 Display message 298
 Fastening 47
 Important safety guidelines 46
 Rear seat belt status indicator 49
 Releasing 48
 Switching belt adjustment on/off (on-board computer) 285
 Warning lamp 325
 Warning lamp (function) 48

- Seats**
- Adjusting (electrically) 102
 - Adjusting the head restraint 102
 - Cleaning the cover 372
 - Correct driver's seat position 100
 - Entry position (3rd row of seats) 106
 - Exit position (3rd row of seats) 107
 - Folding down/up (3rd row of seats) 105
 - Folding the 2nd row of seats forward electrically 107
 - Folding the 2nd row of seats forward manually 106
 - Folding the rear bench seat forwards/back 341
 - Important safety notes 101
 - Overview 101
 - Seat heating problem 109
 - Seat ventilation problem 110
 - Storing settings (memory function) 115
 - Switching seat heating on/off 108
 - Switching the seat ventilation on/off 109
- Selector lever**
- Cleaning 372
- Sensors (cleaning instructions) 370**
- Service**
- see ASSYST PLUS
- Service Centre**
- see Qualified specialist workshop
- Service menu (on-board computer) . 279**
- Service products**
- AdBlue® special additives 427
 - Brake fluid 429
 - Coolant (engine) 429
 - Engine oil 428
 - Fuel 423
 - Important safety notes 423
 - Washer fluid 430
- Settings**
- Factory (on-board computer) 286
 - On-board computer 279
- Setting the air distribution 144**
- Setting the airflow 144**
- SETUP (on-board computer) 287**
- Short journeys (diesel particle filter) 184**
- Sidebag 44**
- Side lamps**
- Switching on/off 120
- Side marker lamp Display message 302**
- Side windows**
- Convenience closing 90
 - Convenience opening 90
 - Hinged side windows 90
 - Important safety notes 89
 - Opening/closing 89
 - Overview 89
 - Problem (malfunction) 93
 - resetting 91
- Sliding sunroof**
- Important safety information 93
 - Opening/closing 94
 - Problem (malfunction) 97
 - Rain closing feature 94
 - Resetting 94
 - see Panorama sliding sunroof
- Snow chains**
- Information 399
 - Snow drive program 249
- Socket**
- Centre console 350
 - Luggage compartment 351
 - Rear compartment 350
- Sockets**
- General notes 350
- Specialist workshop 25**
- Spectacles compartment 340**
- Speed, controlling**
- see Cruise control
- Speed Limit Assist**
- Activating/deactivating the warning function 277
 - Displaying 277
 - Display message 310
 - Display message in the multifunction display 234
 - Function/notes 233
 - Important safety notes 233
- Speedometer**
- Digital 272
 - In the Instrument cluster 30, 267

- Segments 268
 - Selecting the unit of measurement 280
 - see Instrument cluster
 - SPEEDTRONIC**
 - Activating variable 197
 - Deactivating variable 198
 - Display message 314
 - Function/notes 196
 - Important safety notes 196
 - LIM indicator lamp 196
 - Permanent 198
 - Selecting 196
 - Storing the current speed 196
 - Variable 196
 - SRS (Supplemental Restraint System)**
 - Display message 299
 - Introduction 41
 - Warning lamp 332
 - Warning lamp (function) 41
 - Starting (engine)** 161
 - STEER CONTROL** 70
 - Steering (display message)** 321
 - Steering wheel**
 - Adjusting (electrically) 110
 - Adjusting (manually) 110
 - Button overview 33
 - Buttons (on-board computer) 269
 - Cleaning 372
 - Gearshift paddles 171
 - Important safety notes 110
 - Steering wheel heating 111
 - Storing settings (memory function) 115
 - Steering wheel gearshift paddles** 171
 - Steering wheel heating**
 - Problem (malfunction) 111
 - Switching on/off 111
 - Stopwatch (RACETIMER)** 287
 - Stowage areas** 338
 - Stowage compartment**
 - Spectacles compartment 340
 - Stowage compartments**
 - Armrest (under) 339
 - Centre console 340
 - Centre console (rear) 340
 - Cup holder 346
 - Glove compartment 339
 - Important safety information 338
 - Stowage net** 340
 - Stowage space**
 - Stowage net 340
 - Summer tyres** 398
 - Sun blind**
 - Rear side windows 348
 - Sun visor** 347
 - Supplement Restraint System**
 - see SRS (Supplemental Restraint System)
 - Surround lighting (on-board computer)** 282
 - Suspension tuning**
 - AMG RIDE CONTROL sports suspension 215
 - SETUP (on-board computer) 287
 - Switching off the alarm (ATA)** 71
- T**
- Tailgate**
 - Display message 320
 - Emergency unlocking 88
 - Important safety notes 85
 - Limiting the opening angle 88
 - Opening/closing (automatically from inside) 87
 - Opening/closing (automatically from outside) 86
 - Opening/closing (from outside) 86
 - Opening dimensions 431
 - Power closing 84
 - Tail lamps**
 - Display message 301
 - Tank**
 - see Fuel tank
 - Technical data**
 - Capacities 423
 - Emergency spare wheel 417
 - Information 420
 - Trailer loads 433
 - Tyres/wheels 409
 - Vehicle data 431
 - Telephone**
 - Accepting a call 276
 - Display message 322

- Menu (on-board computer) 275
- Number from the phone book 276
- Redialling 276
- Rejecting/ending a call 276
- Telephone compartment 339
- Temperature**
 - Coolant 268
 - Coolant (on-board computer) 286
 - Engine oil (on-board computer) 286
 - Outside temperature 268
 - Setting (climate control) 143
- TEMPOMAT**
 - Function/notes 193
- Theft-deterrent system**
 - ATA (Anti-Theft Alarm system) 71
 - Immobiliser 71
- Through-loading** 341
- Time**
 - see Separate Owner's manual
- Timing (RACETIMER)** 287
- TIREFIT kit** 379
- Top Tether** 55
- Total distance recorder** 271
- Tow-away protection** 71
- Towing**
 - Important safety notes 388
- Towing a trailer**
 - Active Blind Spot Assist 245
 - Active Lane Keeping Assist 248
 - Active Parking Assist 223
 - Axle load, permissible 433
 - Bulb failure indicator for LED lamps 263
 - ESP® (Electronic Stability Program) 67
 - Pulling away with a trailer 162
 - Trailer drive program 250
- Towing away**
 - Fitting the towing eye 390
 - Removing the towing eye 390
 - With both axles on the ground 390
- Tow-starting**
 - Emergency engine starting 391
 - Important safety notes 388
- Trailer**
 - Display message 321
- Trailer coupling**
 - see Towing a trailer
- Trailer towing**
 - 7-pin connector 263
 - Blind Spot Assist 240
 - Cleaning the trailer tow hitch 371
 - Coupling up a trailer 260
 - Decoupling a trailer 261
 - Driving tips 257
 - Folding in the ball coupling 261
 - Folding out the ball coupling 259
 - Important safety notes 257
 - Mounting dimensions 432
 - Parktronic 218
 - Power supply 262
 - Problem (fault) 264
 - Shift range 170
 - Trailer loads 433
- Transmission**
 - see Automatic transmission
- Transmission position display** 168
- Transmission position display (DIRECT SELECT lever)** 168
- Transporting the vehicle** 391
- Travelling uphill**
 - Brow of hill 192
 - Driving downhill 192
 - Maximum gradient-climbing capability 192
- Trim pieces (cleaning instructions)** 372
- Trip computer (on-board computer)** 271
- Trip meter**
 - Calling up 271
 - Resetting (on-board computer) 272
- Turn signal**
 - see Turn signals
- Turn signals**
 - Switching on/off 121
- TV**
 - Operating (on-board computer) 275
 - see Separate operating instructions
- Two-way radio**
 - Frequencies 421
 - Installation 421
 - Transmission output (maximum) 421

Type identification plate

see Vehicle identification plate

Tyre pressure

Calling up (on-board computer)	402
Display message	315
Not reached (TIREFIT)	381
Reached (TIREFIT)	381
Recommended	399

Tyre pressure loss warning

Important safety notes	401
Restarting	401

Tyre pressure monitor

Checking the tyre pressure electronically	402
Function/notes	402
Restarting	403
Warning lamp	336
Warning message	403

Tyres

Changing a wheel	404
Checking	397
Direction of rotation	404
Display message	315
Important safety notes	396
M+S tyres	398
MOExtended tyres	398
Replacing	404
Service life	397
Storing	405
Tyre size (data)	409
Tyre tread	397
see Flat tyre	

U

Unladen weight	431
-----------------------------	-----

Unlocking

Emergency unlocking	84
From inside the vehicle (central unlocking button)	83

V

Vanity mirror (in sun visor)	348
---	-----

Variable SPEEDTRONIC

see SPEEDTRONIC

Vehicle

Correct use	26
Data acquisition	26
Display message	319
Electronics	421
Equipment	24
Implied warranty	26
Individual settings	279
Leaving parked up	184
Locking (in an emergency)	85
Locking (key)	77
Lowering	409
Pulling away	161
Raising	406
Registration	25
Securing from rolling away	405
Towing away	388
Transporting	391
Unlocking (in an emergency)	84
Unlocking (key)	77
Vehicle data	431

Vehicle battery

see Battery (vehicle)

Vehicle data	431
---------------------------	-----

Vehicle dimensions	431
---------------------------------	-----

Vehicle emergency locking	85
--	----

Vehicle identification number

see VIN

Vehicle identification plate	422
---	-----

Vehicle level

AMG RIDE CONTROL sports suspension	215
--	-----

Vehicle level (display message)	307
--	-----

Vehicle tool kit	377
-------------------------------	-----

Vehicle weights	431
------------------------------	-----

Video

Operating the DVD	275
-------------------------	-----

VIN	422
------------------	-----

W**Warning and indicator lamps**

ABS	327
Brakes	326
Distance warning signal	335
ESP®	329
ESP® OFF	330
Fuel tank	333

- LIM (cruise control) 193
- LIM (DISTRONIC PLUS) 200
- LIM (variable SPEEDTRONIC) 196
- Overview 32, 324
- PASSENGER AIRBAG OFF 52
- Reserve fuel 333
- Seat belt 325
- SRS 332
- Tyre pressure monitor 336
- Warning triangle** 376
- Washer fluid**
 - Display message 322
- Wheel bolt tightening torque** 409
- Wheel chock** 405
- Wheels**
 - Changing/replacing 404
 - Changing a wheel 404
 - Checking 397
 - Cleaning 369
 - Cleaning (warning) 405
 - Emergency spare wheel 414
 - Fitting a new wheel 408
 - Fitting a wheel 405
 - Important safety notes 396
 - Overview 396
 - Removing a wheel 407
 - Storing 405
 - Tightening torque 409
 - Wheel size/tyre size 409
- Windowbag**
 - Display message 300
 - Operation 45
- Windows**
 - Cleaning 369
 - see Side windows
- Windscreen**
 - Demisting 145
 - Infrared reflective 358
- Windscreen washer fluid**
 - see Windscreen washer system
- Windscreen washer system**
 - Notes 430
 - Topping up 364
- Windscreen wipers**
 - Problem (malfunction) 133
 - Rear window wiper 132
 - Replacing the wiper blades 132
 - Switching on/off 131
- Winter driving**
 - General notes 398
- Winter operation**
 - Overview 398
 - Radiator cover 362
 - Slippery road surfaces 188
 - Snow chains 399
 - Snow drive program 249
- Winter tyres**
 - Limiting the speed (on-board computer) 283
 - M+S tyres 398
- Wiper blades**
 - Cleaning 369
 - Important safety notes 132
 - Replacing 132
 - Replacing (on the rear window) 133
 - Replacing (windscreen) 132
- Wooden trim (cleaning instructions)** 372
- Workshop**
 - see Qualified specialist workshop

Protection of the environment

General notes

Environmental note

Daimler's declared policy is one of comprehensive environmental protection.

The objectives are for the natural resources which form the basis of our existence on this planet to be used sparingly and in a manner which takes the requirements of both nature and humanity into account.

You too can help to protect the environment by operating your vehicle in an environmentally-responsible manner.

Fuel consumption and the rate of engine, transmission, brake and tyre wear depend on the following factors:

- operating conditions of your vehicle
- your personal driving style

You can influence both factors. You should bear the following in mind:

Operating conditions:

- avoid short trips as these increase fuel consumption.
- make sure that the tyre pressures are always correct.
- do not carry any unnecessary weight.
- keep an eye on the vehicle's fuel consumption.
- remove roof racks once you no longer need them.
- a regularly serviced vehicle will contribute to environmental protection. You should therefore adhere to the service intervals.
- always have service work carried out at a qualified specialist workshop.

Personal driving style:

- do not depress the accelerator pedal when starting the engine.
- do not warm up the engine with the vehicle stationary.
- drive carefully and maintain a safe distance from the vehicle in front.

- avoid frequent, sudden acceleration.
- change gear in good time and use each gear only up to $\frac{2}{3}$ of its maximum engine speed.
- switch off the engine in stationary traffic.

Returning an end-of-life vehicle

Mercedes-Benz will take back your Mercedes-Benz to dispose of it in an environmentally responsible manner, in accordance with the European Union (EU) End of Life Vehicles Directive.

The End of Life Vehicles Directive applies to vehicles with a gross vehicle weight of up to 3.5 t, in accordance with national regulations. For several years, Mercedes-Benz has been meeting all the legal requirements for a design which allows for recycling and re-use. There is a network of return points and disassembly plants which can recycle your vehicle in an environmentally-responsible manner. The methods employed in vehicle and parts recycling are constantly being developed and improved. This means that your Mercedes-Benz will also continue to meet even the increased recycling quotas in the future in good time. You can obtain further information from your national Mercedes-Benz homepage or your national hotline number.

Product information

Mercedes-Benz recommends that you use genuine Mercedes-Benz parts, conversion parts and accessories that have been approved for the type of vehicle.

Mercedes-Benz tests genuine parts and conversion parts and accessories that have been specifically approved for your vehicle for their reliability, safety and suitability. Despite ongoing market research, Mercedes-Benz is unable to assess other parts. Therefore, Mercedes-Benz accepts no responsibility for the use of such parts in Mercedes-Benz vehi-

cles. This is also the case, even if they have been independently or officially approved. The use of non-approved parts could affect your vehicle's operating safety.

Mercedes-Benz therefore recommends that you use genuine Mercedes-Benz parts, conversion parts and accessories that have been approved for the type of vehicle.

Genuine Mercedes-Benz parts, approved conversion parts and accessories are available from a Mercedes-Benz Service Centre. Here, you will receive advice about permissible technical modifications, and the parts will be professionally fitted.

Owner's Manual

General notes

Before you first drive off, read this Owner's Manual carefully and familiarise yourself with your vehicle.

For your own safety and a longer vehicle life, follow the instructions and warning notices in this manual. Disregarding them may lead to damage to the vehicle or personal injury.

Vehicle equipment

This Owner's Manual describes all models and all standard and optional equipment available for your vehicle at the time of publication of the Owner's Manual. Country-specific differences are possible. Note that your vehicle may not be fitted with all features described. This is also the case for systems and functions relevant to safety. Therefore, the equipment on your vehicle may differ from that in the descriptions and illustrations.

The original purchase contract documentation for your vehicle contains a list of all of the systems in your vehicle.

Should you have any questions concerning equipment and operation, please consult a Mercedes-Benz Service Centre.

The Owner's Manual and Service Booklet are important documents and should be kept in the vehicle.

Operating safety

Important safety notes

WARNING

All work on the vehicle and, in particular, work relevant to safety or on safety-related systems must be carried out at a qualified specialist workshop.

WARNING

Some safety systems only function when the engine is running. You should therefore never switch off the engine when driving. Otherwise, the safety systems of your vehicle may not function correctly and as a result will no longer protect you and other persons as intended. In addition, there is a risk that you may lose control of your vehicle and thus cause an accident.

WARNING

Work carried out incorrectly, or alterations made to the vehicle, e.g. re-routing of cables under coverings, could cause the safety systems of your vehicle to stop working properly. The safety systems would thus no longer protect you and other persons as intended. In addition, there is a risk that you may lose control of your vehicle and thus cause an accident.

All work and alterations to the vehicle, e.g. installations or modifications, should therefore be carried out at a qualified specialist workshop.

WARNING

If work on electronic equipment and its software is carried out incorrectly, this equipment could stop working. The electronic systems are networked via interfaces. Tampering with these electronic systems could cause mal-

functions in systems which have not been modified. Malfunctions such as these can seriously jeopardise the vehicle's operating safety and therefore your own safety.

You should therefore have all work and modifications to electronic components carried out at a qualified specialist workshop.

Declarations of conformity

Wireless vehicle components

The following information applies to all components of the vehicle and the COMAND system which receive and/or transmit radio waves:

The components of this vehicle which receive and/or transmit radio waves are compliant with the basic requirements and other relevant provisions of Directive 1999/5/EC. You can obtain further information from any Mercedes-Benz Service Centre.

Electromagnetic compatibility

The electromagnetic compatibility of the vehicle components has been checked and certified according to the currently valid version of Directive 72/245/EEC or the equivalent ECE Regulation ECE-R 10.

Diagnostics connection

WARNING

If you connect equipment to a diagnostics connection, it can affect the operation of the vehicle systems. This could compromise the operating safety of your vehicle while driving. There is a risk of an accident.

Do not connect any equipment to a diagnostics connection.

WARNING

Loose equipment or cables hanging from a device which are connected to a diagnostic connection could impede pedal clearance.

The equipment or cables could get caught between the pedals when driving and braking suddenly. This could impair the function of the pedals. There is a risk of accident.

Do not attach any equipment or cables in the driver's footwell.

! If the engine is switched off and equipment on the diagnostics connection is used, the starter battery may discharge.

The diagnostics connection is only intended for the connection of diagnostic equipment at a qualified specialist workshop.

Connecting equipment to the diagnostics connection can lead to emissions monitoring information being reset, for example. This may lead to the vehicle failing to meet the requirements of the next emissions test during the main inspection.

Qualified specialist workshop

A qualified specialist workshop has the necessary special skills, tools and qualifications to correctly carry out any necessary work on your vehicle. This particularly applies to work relevant to safety.

Observe the notes in the Service Booklet.

Always have the following work carried out at a qualified specialist workshop:

- work relevant to safety
- service and maintenance work
- repair work
- modifications, installations and conversions
- work on electronic components

Mercedes-Benz recommends that you use a Mercedes-Benz Service Centre.

Vehicle registration

Mercedes-Benz may ask its Service Centres to carry out technical inspections on certain

vehicles. The quality or safety of the vehicle is improved as a result of the inspection. Mercedes-Benz can only inform you about vehicle checks if it has your registration data. It is possible that your vehicle has not yet been registered in your name in the following cases:

- if your vehicle was not purchased at an authorised specialist dealer.
- if your vehicle has not yet been examined at a Mercedes-Benz Service Centre.

It is advisable to register your vehicle with a Mercedes-Benz Service Centre.

Inform Mercedes-Benz as soon as possible about any change in address or vehicle ownership.

Correct use

WARNING

Various warning stickers are affixed to your vehicle. Their purpose is to draw your attention, and the attention of others, to various dangers. Therefore, do not remove any warning stickers unless the sticker clearly states that you may do so.

If you remove the warning stickers, you or others could be injured by failing to recognise certain dangers.

Observe the following information when driving your vehicle:

- the safety notes in this manual
- the Technical Data section in this manual
- traffic rules and regulations
- laws and safety standards pertaining to motor vehicles

Implied warranty

! Follow the instructions in this manual about the proper operation of your vehicle as well as about possible vehicle damage. Damage to your vehicle that arises from

culpable contraventions against these instructions are not covered either by Mercedes-Benz implied warranty or by the New or Used-Vehicle Warranty.

Data stored in the vehicle

Fault data

Components which are critical for vehicle operation are equipped with fault data memories as standard. There are also data storage devices which record how vehicle components have reacted in certain driving situations (e.g. airbag deployment or ESP® intervention).

This data is used exclusively to:

- assist in the rectification of faults and defects
- help Mercedes-Benz optimise and develop vehicle functions

The data cannot be used to trace the vehicle's movements.

When your vehicle is serviced by Mercedes-Benz, this technical information can be read out from the fault memory. This is performed by authorised employees of the Mercedes-Benz service network using special diagnostic computers.

After a fault has been rectified, the information is deleted from the memory. Other memory data is constantly overwritten.

Other devices that store data

Depending on the equipment level, your vehicle may feature communications and/or entertainment systems (e.g. navigation devices, telephone systems). These allow you to save and edit data required for the operation of the respective device.

Further information on operation (e.g. on deleting data) can be found in the separate operating instructions.

Cockpit	28
Instrument cluster	30
Multifunction steering wheel	33
Centre console	34
Overhead control panel	37
Door control panel	38

Cockpit

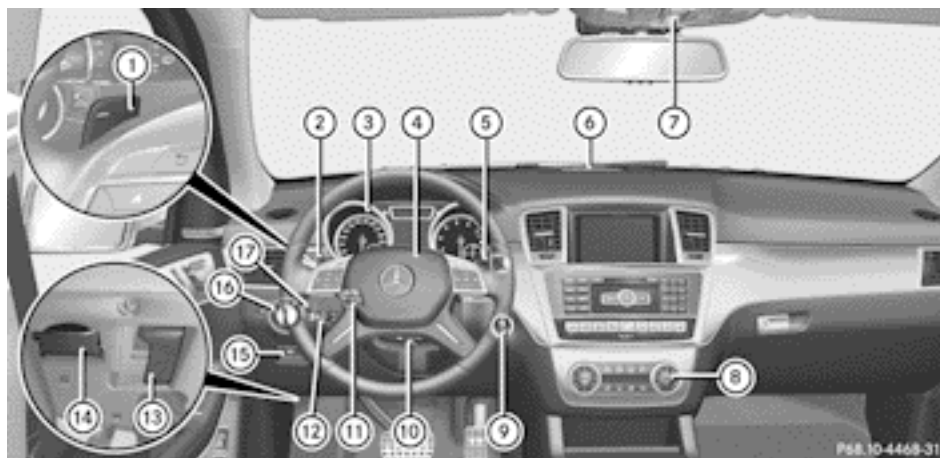

	Function	Page
①	Steering wheel gearshift paddles	171
②	Combination switch	121
③	Instrument cluster	30
④	Horn	
⑤	DIRECT SELECT lever	167
⑥	PARKTRONIC warning display	216
⑦	Overhead control panel	37
⑧	Climate control systems	136
⑨	Ignition lock Start/Stop button	159 159

	Function	Page
⑩	Adjusts the steering wheel manually	110
⑪	Adjusts the steering wheel electrically Steering wheel heating	110 111
⑫	Cruise control lever	193
⑬	Opens the bonnet	360
⑭	Diagnostics connection	25
⑮	Electric parking brake	182
⑯	Light switch	119
⑰	Night View Assist Plus	235

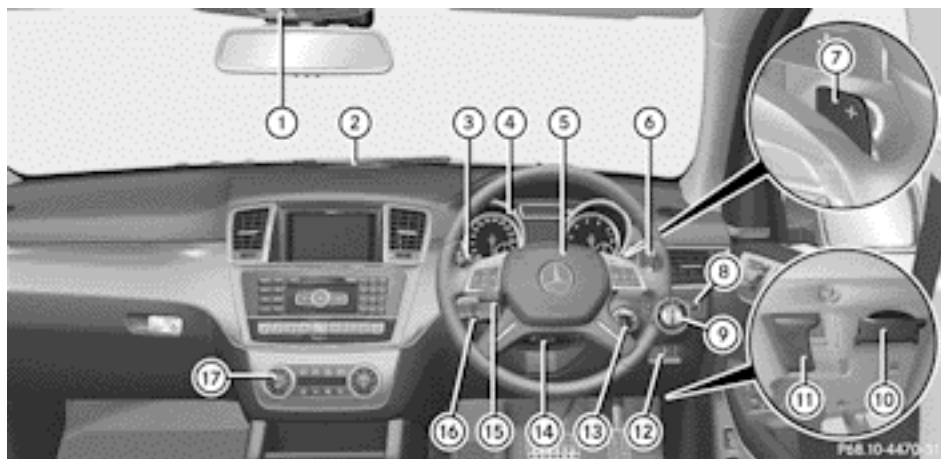

	Function	Page
①	Overhead control panel	37
②	PARKTRONIC warning display	216
③	Combination switch	121
④	Instrument cluster	30
⑤	Horn	
⑥	DIRECT SELECT lever	167
⑦	Steering wheel gearshift paddles	171
⑧	Night View Assist Plus	235
⑨	Light switch	119
⑩	Diagnostics connection	25

	Function	Page
⑪	Opens the bonnet	360
⑫	Electric parking brake	182
⑬	Ignition lock Start/Stop button	159 159
⑭	Adjusts the steering wheel manually	110
⑮	Adjusts the steering wheel electrically Steering wheel heating	110 111
⑯	Cruise control lever	193
⑰	Climate control systems	136

Instrument cluster

Displays and controls

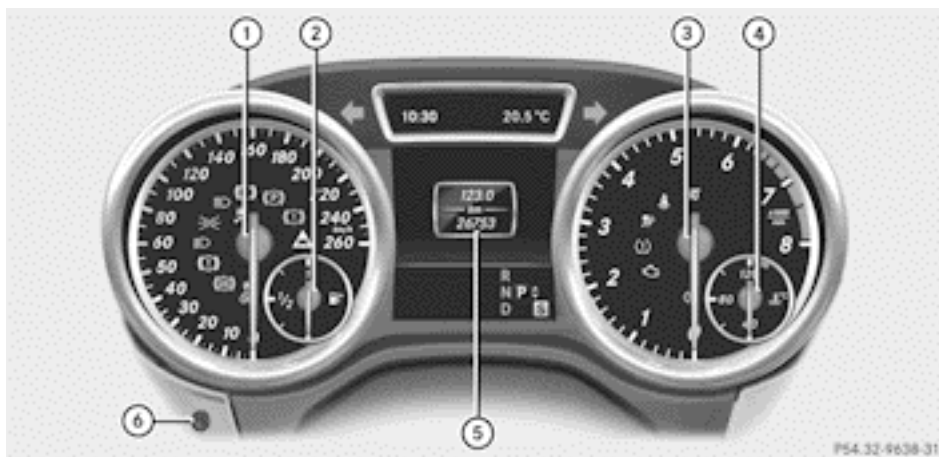

i Instrument cluster: kilometres

	Function	Page
①	Speedometer with segments	268
②	Fuel gauge	
③	Rev counter	268

	Function	Page
④	Coolant temperature	268
⑤	Multifunction display	270
⑥	Instrument cluster lighting	268

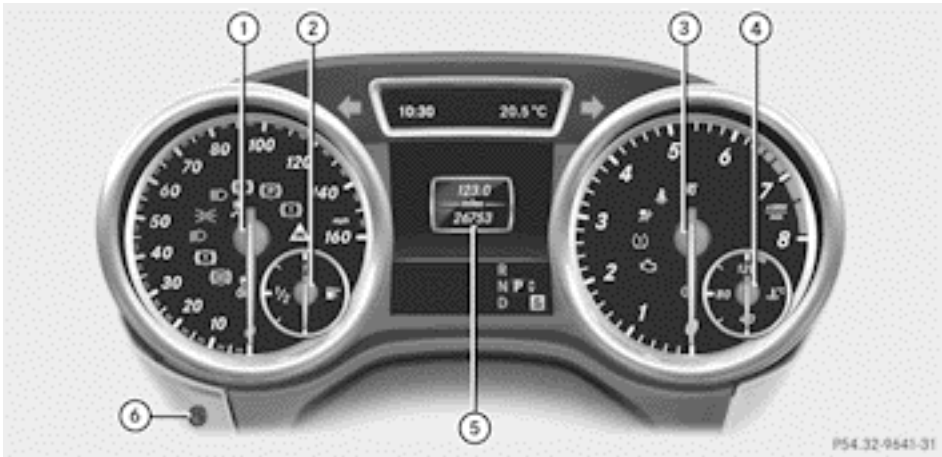

i Instrument cluster: miles

	Function	Page
①	Speedometer with segments	268
②	Fuel gauge	
③	Rev counter	268

	Function	Page
④	Coolant temperature	268
⑤	Multifunction display	270
⑥	Instrument cluster lighting	268

Warning and indicator lamps

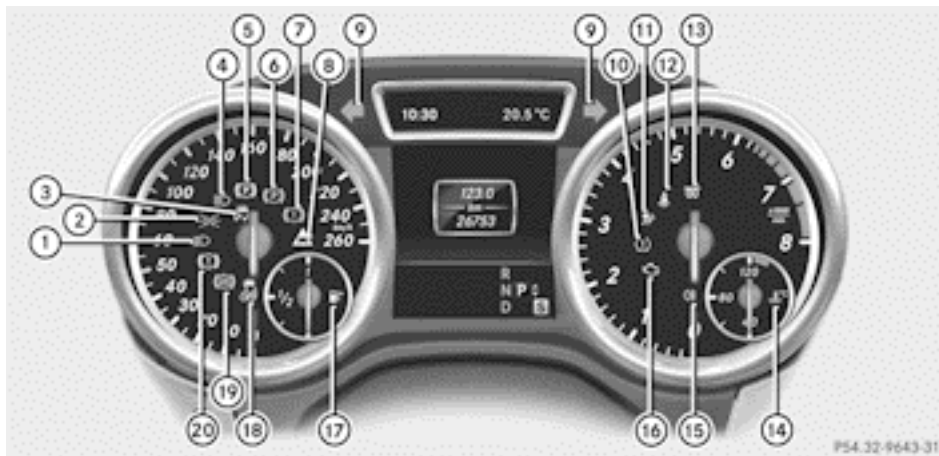













	Function	Page
①	Dipped-beam headlamps	120
②	Side lamps	120
③	ESP®	329
④	Main-beam headlamp	122
⑤	Electric parking brake (red)	332
⑥	Electric parking brake (yellow)	332
⑦	Brakes (yellow)	326
⑧	Distance warning	335
⑨	Turn signals	121
⑩	Tyre pressure monitor	336

	Function	Page
⑪	SRS	332
⑫	Seat belt	325
⑬	Diesel engine: pre-glow	161
⑭	Coolant	333
⑮	Rear foglamp	120
⑯	Engine diagnostics	333
⑰	Reserve fuel	333
⑱	ESP® OFF	329
⑲	ABS	327
⑳	Brakes (red)	326

Multifunction steering wheel







	Function	Page
①	Multifunction display	270
②	Audio/COMAND display; see the separate operating instructions	
③	 Switches on LINGUA-TRONIC; see the separate operating instructions	
④	 Rejects or ends a call Exits telephone book/ redial memory  Makes or accepts a call Switches to the redial memory   Adjusts the volume  Mute	275



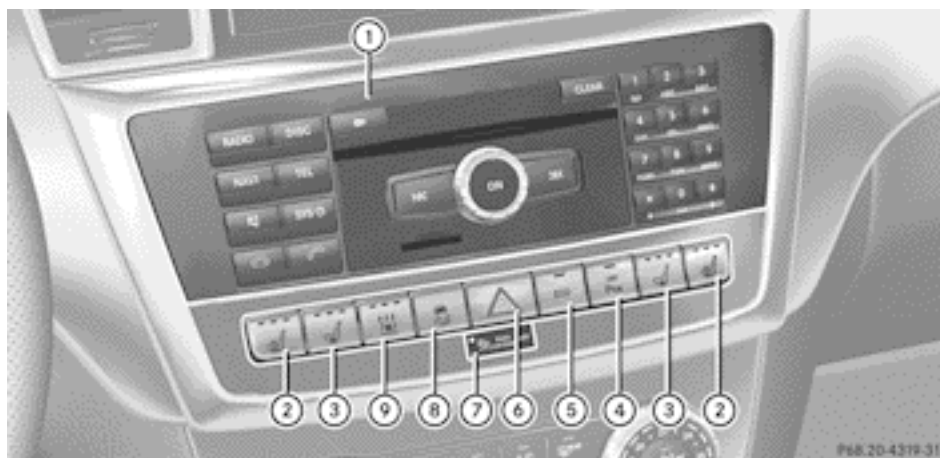

	Function	Page
⑤	  Selects a menu   Selects a submenu or scrolls through lists  Confirms your selection Hides display messages	269 269 269 290
⑥	 Back Switches off LINGUA-TRONIC; see the separate operating instructions	269

Centre console

Centre console, upper section





	Function	Page
①	Audio 20/COMAND Online: see the separate operating instructions	
②	 Seat heating	108
③	 Seat ventilation	109
④	 PARKTRONIC	216
⑤	 ECO start/stop function	163

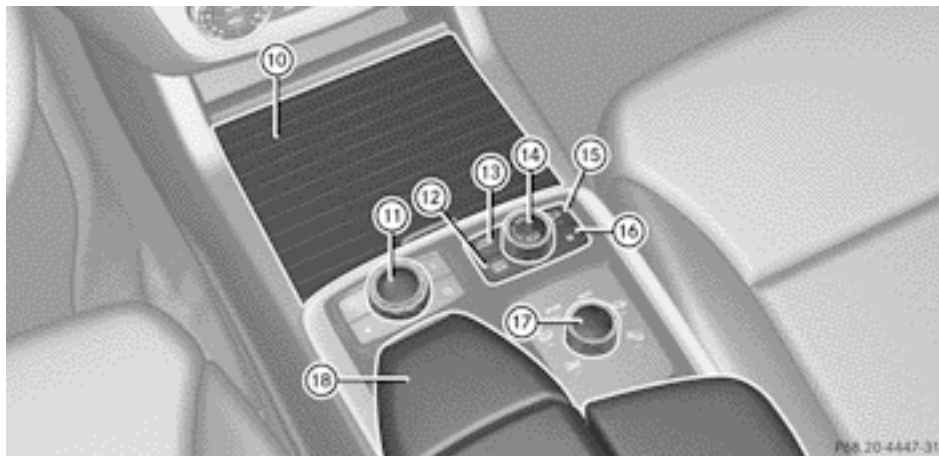

	Function	Page
⑥	 Hazard warning lamps	122
⑦	 PASSENGER AIRBAG OFF indicator lamp	52
⑧	 ESP®	66
⑨	 Auxiliary heating	148

Centre console, lower section



i Vehicles with ON&OFFROAD menu



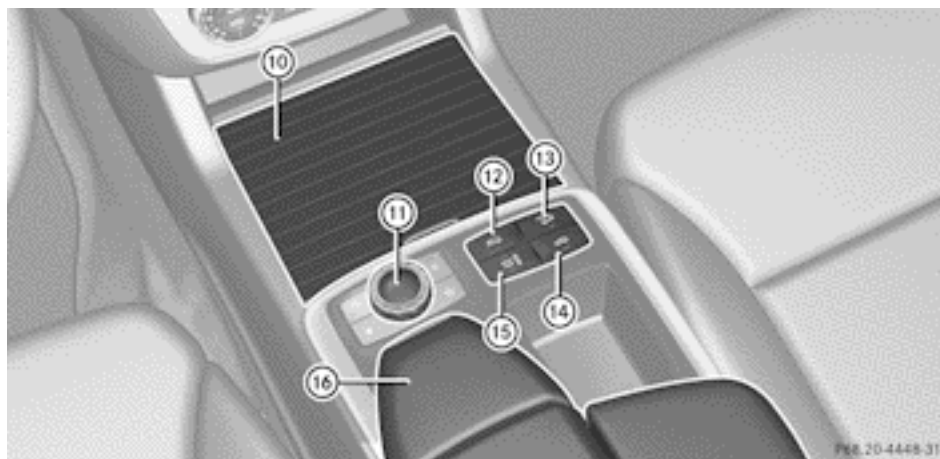

	Function	Page
⑩	Stowage compartment Cup holders Ashtray Cigarette lighter Power socket	340 346 349 349 350
⑪	COMAND controller: see the separate operating instructions	
⑫	 ON&OFFROAD menu button	256
⑬	 LOW RANGE off-road gear	254

	Function	Page
⑭	 Level control	207
⑮	 DSR (Downhill Speed Regulation)	251
⑯	 Manual drive program	172
⑰	Selector wheel for on-road programs Selector wheel for off-road programs	248 253
⑱	Stowage compartment	339









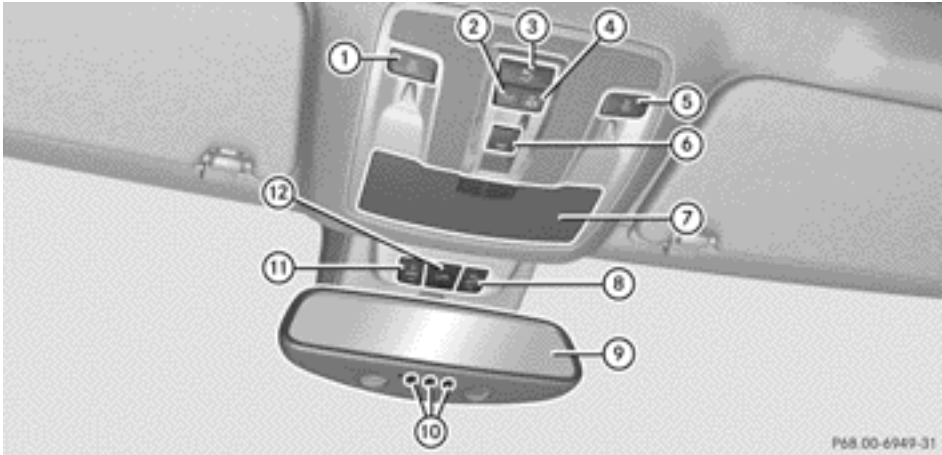

i Vehicles without ON&OFFROAD menu and AMG vehicles



	Function	Page
⑩	Stowage compartment	340
	Cup holders	346
	Ashtray	349
	Cigarette lighter	349
	Power socket	350
⑪	COMAND controller: see the separate operating instructions	
⑫	 Selects the off-road program	252
	Selects the drive program (AMG vehicles)	170

	Function	Page
⑬	 DSR (Downhill Speed Regulation)	251
⑭	 Level control	213
⑮	 Adaptive Damping System	212
	 Adjusts AMG RIDE CONTROL (AMG vehicles)	215
⑯	Stowage compartment	339

Overhead control panel











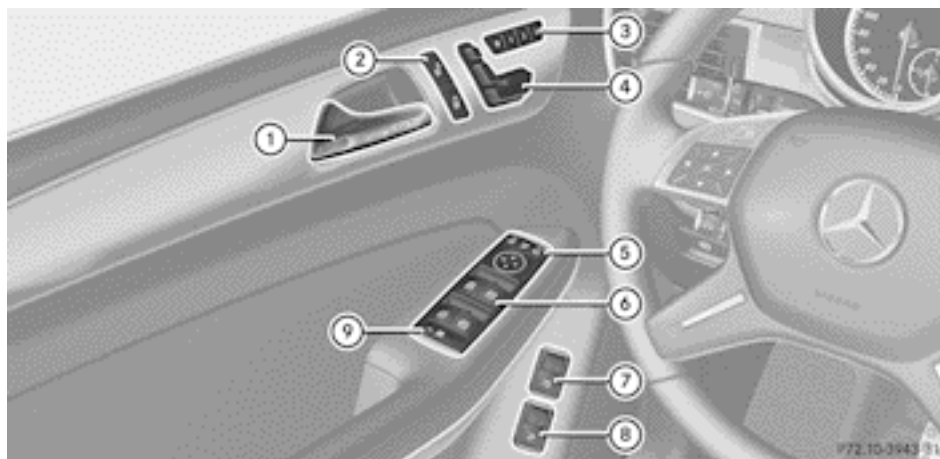

	Function	Page
①	 Switches the left-hand reading lamp on/off	126
②	 Switches the front interior lighting on	127
③	 Switches the rear interior lighting on/off	127
④	 Switches the front interior lighting/automatic interior lighting control off	127
⑤	 Switches the right-hand reading lamp on/off	126
⑥	 Opens/closes the sliding sunroof	94
	 Opens/closes the panorama sliding sunroof with roller sunblinds	95





	Function	Page
⑦	Spectacles compartment	340
⑧	 Deactivates tow-away protection	71
⑨	Rear-view mirror	112
⑩	Buttons for the garage door opener	352
⑪	 Deactivates the interior motion sensor	72
⑫	Switches on the Mercedes-Benz emergency call system	

Door control panel

At a glance



	Function	Page
①	Opens the door	82
②	  Unlocks/locks the vehicle	83
③	    Stores settings for the seat, exterior mirrors and steering wheel (memory function)	115
④	Adjusts the seat	101
⑤	    Adjusts and folds the exterior mirrors in/out electrically	112

	Function	Page
⑥	 Opens/closes the side windows	89
⑦	 Opens/closes the hinged power side windows	90
⑧	 Opens/closes the tailgate	87
⑨	 Activates/deactivates the override feature for the side windows in the rear compartment	60

Useful information	40
Occupant safety	40
Children in the vehicle	50
Driving safety systems	60
Anti-theft systems	71

Useful information

- i** This Owner's Manual describes all models, series and optional equipment for your vehicle that were available at the time of going to press. National variations are possible. Note that your vehicle may not be equipped with all of the functions described. This is also the case for systems and functions relevant to safety.
- i** Read the information on qualified specialist workshops: (▷ page 25).

Occupant safety

Important safety notes

WARNING

If service work is not carried out correctly, the operating safety of your vehicle may be affected. This could cause you to lose control of your vehicle and cause an accident. Moreover, the safety systems may no longer be able to protect you or others as they are designed to do.

Always have service work carried out at a qualified specialist workshop.

WARNING

Modifications to or work performed incorrectly on the following parts can result in the restraint systems not functioning as intended:

- the restraint system, consisting of seat belts and their anchorage points, belt tensioners, belt force limiters and airbags
- the wiring
- networked electronic systems

Airbags and belt tensioners could fail to deploy or be triggered in an accident despite the deceleration force being sufficient to trigger the systems, or could be triggered unintentionally. For this reason, never make any modifications to the restraint systems.

Therefore, you must not tamper with electronic components or their software.

The seat belts, together with SRS (Supplemental Restraint System), are complementary, co-ordinated restraint systems (▷ page 41). They reduce the risk of injury in specific, pre-defined types of accident situations and thereby increase occupant safety. However, seat belts and airbags generally do not protect against objects penetrating the vehicle from the outside.

To ensure that the restraint systems can deliver their full potential protection, make sure that:

- the seat and head restraint are adjusted properly (▷ page 100).
- the seat belt has been fastened properly (▷ page 47).
- the airbags can inflate unrestricted if deployed (▷ page 42).
- the steering wheel is adjusted properly (▷ page 100).
- the restraint systems have not been modified.

An airbag increases the protection of vehicle occupants wearing a seat belt. However, airbags are only an additional restraint system which complements, but does not replace, the seat belt. All vehicle occupants must wear their seat belt correctly at all times, even if the vehicle is equipped with airbags. The airbags are not deployed in all types of accidents. For example, if the protective capacity of correctly fastened seat belts is not increased by deploying the airbags, the airbags will not deploy.

Airbag deployment only provides increased protection if the seat belt is worn correctly. First, the seat belt helps to keep the vehicle occupant in the best position in relation to the airbag. Second, in a head-on collision, for example, the seat belt prevents the vehicle occupant from being propelled towards the point of impact.

SRS (Supplemental Restraint System)

Introduction

SRS consists of:

- the SRS warning lamp 
- airbags
- the airbag control unit with crash sensors
- belt tensioners for the front seat belts and the outer seat belts in the rear
- belt force limiters



SRS reduces the risk of occupants coming into contact with the vehicle's interior in the event of an accident. It can also reduce the forces to which occupants are subjected during an accident.

SRS warning lamp

WARNING

If SRS is malfunctioning, individual systems may be triggered unintentionally or might not be triggered in the event of an accident with a high rate of vehicle deceleration.

A malfunction has occurred if:

- the  SRS warning lamp does not light up when the ignition is switched on.
- the engine is running and the  SRS warning lamp does not go out after a few seconds.
- the engine is running and the  SRS warning lamp lights up again.

In this case, have SRS checked immediately at a qualified specialist workshop.

SRS functions are checked regularly when you switch on the ignition and when the engine is running. Therefore, malfunctions can be detected in good time.

The  SRS warning lamp in the instrument cluster lights up when the ignition is switched on. It goes out no later than a few seconds after the engine is started.

Triggering of belt tensioners, belt force limiters and airbags

During the first stage of a collision, the airbag control unit evaluates important physical data relating to vehicle deceleration or acceleration, such as:

- duration
- direction
- magnitude

Based on the evaluation of this data, the airbag control unit pre-emptively triggers the belt tensioners in the first stage.

If there is an even higher rate of vehicle deceleration or acceleration in a longitudinal direction, the front airbags are also deployed.

Your vehicle has adaptive, two-stage front airbags. The airbag control unit evaluates vehicle deceleration or acceleration in the event of a collision. In the first deployment stage, the front airbag is filled with enough propellant gas to reduce the risk of injuries. The front airbag is fully deployed if a second deployment threshold is reached within a few milliseconds.

The belt tensioner and airbag triggering thresholds are variable and are adapted to the rate of deceleration or acceleration of the vehicle. This process is pre-emptive in nature. The triggering process must take place in good time at the start of the collision.

The rate of vehicle deceleration or acceleration and the direction of the force are essentially determined by:

- the distribution of forces during the collision
- the collision angle
- the deformation characteristics of the vehicle
- the characteristics of the object with which the vehicle has collided

Factors which can only be seen and measured after a collision has occurred do not play a decisive role in the deployment of an airbag,

nor do they provide an indication of airbag deployment.

The vehicle may be deformed significantly, e.g. the bonnet or the wing, without an airbag being deployed. This is the case if only parts which are relatively easily deformed are affected and the rate of deceleration is not high. Conversely, airbags may be deployed even though the vehicle suffers only minor deformation. This is the case if, for example, very rigid vehicle parts such as longitudinal body members are hit, and sufficient deceleration occurs as a result.

i The front belt tensioners can only be triggered if the seat belt tongues on the front seats are correctly engaged in the seat belt buckles.

i Not all airbags are deployed in an accident. The different airbag systems work independently of each other.

How the airbag system works is determined by the severity of the accident detected, especially the vehicle deceleration or acceleration, and the apparent type of accident:

- head-on collision
- side impact
- overturn

Airbags

Important safety notes

WARNING

Airbags provide additional protection; they are not, however, a substitute for seat belts. Observe the following notes to reduce the risk of serious or even fatal injury caused by airbag deployment:

- all vehicle occupants – in particular, pregnant women – must wear their seat belt correctly at all times and lean back against the backrest, which should be positioned as close to the vertical as possible. The

head restraint must support the back of the head at about eye level.

- always secure children less than 1.50 m tall or under 12 years of age in suitable child restraint systems.
- all vehicle occupants must select a seat position that is as far away from the airbag as possible. The driver's seat position must allow the vehicle to be driven safely. The driver's chest should be as far away from the centre of the driver's airbag cover as possible.
- move the front-passenger seat as far back as possible. This is especially important if you have secured a child in a child restraint system on the front-passenger seat.
- vehicle occupants – in particular, children – must not lean their heads into the area of the window in which the sidebag/windowbag is deployed.
- rearward-facing child restraint systems must not be fitted to the front-passenger seat unless the front-passenger airbag has been disabled. On the front-passenger seat, the front-passenger airbag is disabled if a child restraint system with a transponder for automatic child seat recognition is fitted to the front-passenger seat in a vehicle equipped with automatic child seat recognition. The  PASSENGER AIRBAG OFF indicator lamp must be continuously lit.

If the front-passenger seat of your vehicle does not have automatic child seat recognition, or your rearward-facing child restraint system does not have a transponder for automatic child seat recognition, children must be secured in a child restraint system on a suitable seat in the rear. If you secure a forward-facing child restraint system to the front-passenger seat, you must move the front-passenger seat as far back as possible.

- make sure there are no heavy or sharp-edged objects in the pockets of clothing.

- do not lean forwards, e.g. over the cover of the driver's/front-passenger front airbag, particularly when the vehicle is in motion.
- do not put your feet on the dashboard.
- only hold the steering wheel on the outside. This allows the airbag to be fully deployed. You could be injured if the airbag is deployed and you are holding the inside of the steering wheel.
- do not lean on the doors from inside the vehicle.
- make sure that there are no people, animals or objects between the vehicle occupants and the area where the airbags are deployed.
- do not place any objects between the seat backrest and the door.
- do not hang any hard objects, e.g. coat hangers, on the grab handles or coat hooks.
- do not attach accessories, e.g. cup holders, to the doors.

It is not possible to rule out a risk of injury being caused by an airbag, due to the high speed at which the airbag must be deployed.

WARNING

Airbag functionality can only be assured if the following parts are not covered and no badges or stickers are attached to them:

- padded steering wheel boss
- kneebag cover below the steering column
- front-passenger airbag cover
- outer side of seat bolsters

WARNING

When an airbag deploys, a small amount of powder is released. The powder may cause short-term breathing difficulties to persons suffering from asthma or other pulmonary conditions.

In order to prevent potential breathing difficulties, you should leave the vehicle as soon as it is safe to do so. You can also open the window to allow fresh air to enter the vehicle

interior. The powder does not constitute a health hazard and does not indicate that there is a fire in the vehicle.

WARNING

The airbag parts are hot after the airbag has been deployed. Do not touch them as you could burn yourself.

Have the airbags replaced at a qualified specialist workshop. Otherwise, occupants are not protected by the airbags in the event of another accident.

Airbag deployment slows down and restricts the movement of the vehicle occupant.

If the airbags are deployed, you will hear a bang and a small amount of powder may also be released. Only in rare cases will the bang affect your hearing. The powder that is released generally does not constitute a health hazard. The  SRS warning lamp lights up.

The airbag installation locations are identified by the AIRBAG symbol.

Front airbags

- ❗ Do not place heavy objects on the front-passenger seat. The system may then detect that the seat is occupied and if there is an accident, the restraint systems on the front-passenger side could be deployed. Have restraint systems that have been triggered replaced.



Driver's airbag ① deploys in front of the steering wheel; front-passenger front air-

bag ② deploys in front of and above the glove compartment.

The front airbags increase protection for the driver's and front-passenger's head and chest.

They are deployed:

- at the start of an accident with a high rate of vehicle acceleration or deceleration in a longitudinal direction
- if the system determines that airbag deployment can offer additional protection to that provided by the seat belt
- depending on whether the seat belt is being used
- independently of other airbags in the vehicle

If the vehicle overturns, the front airbags are generally not deployed. The front airbags are deployed if the system detects high vehicle deceleration in a longitudinal direction.

Vehicles with automatic child seat recognition in the front-passenger seat: the front-passenger airbag is only activated if the system determines that the front-passenger seat is occupied. The  PASSENGER AIRBAG OFF indicator lamp on the centre console does not light up (> page 52).

If a child restraint system is fitted on the front-passenger seat and the  PASSENGER AIRBAG OFF indicator lamp in the centre console does not light up:

- a child restraint system without a transponder for automatic child seat recognition is fitted, or
- a child restraint system with a transponder for automatic child seat recognition is not properly fitted.

Driver's kneebag



Driver's kneebag ① deploys under the steering column. The driver's kneebag is always deployed along with the driver's front airbag. The driver's kneebag is designed to operate together with the front airbags in frontal impacts if certain thresholds are exceeded. The driver's kneebag operates best in conjunction with correctly positioned and fastened seat belts.

The driver's kneebag increases protection of the driver against:

- knee injuries
- thigh injuries
- lower leg injuries

Sidebags

WARNING

If you wish to use seat covers, Mercedes-Benz recommends that, for safety reasons, you only use seat covers that have been approved for Mercedes-Benz vehicles.

The seat covers must have a special tear seam for sidebags. Otherwise, the sidebags cannot deploy correctly and would fail to provide the intended protection in the event of an accident. Appropriate seat covers can be obtained, for example, from a Mercedes-Benz Service Centre.

WARNING

Sensors to control the airbags are located in the doors. Therefore, do not make any modifications to the doors or door trim, e.g. retro-

fitting loudspeakers. Damage to the doors can affect operation of the sidebags.

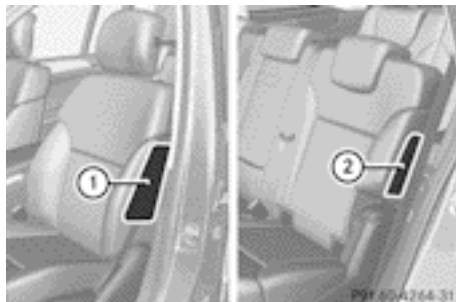

Front sidebags ① and sidebags in the 2nd row of seats ② inflate next to the outer seat cushion.

When deployed, the sidebags offer additional protection for the thorax and, on the front seats, the pelvis of the vehicle occupants on the side of the vehicle on which the impact occurs. However, they do not protect the:

- head
- neck
- arms

The sidebags are deployed:

- on the side on which an impact occurs
- at the start of an accident with a high rate of lateral vehicle deceleration or acceleration, e.g. in a side impact
- independently of the use of the seat belt
- independently of the front airbags
- independently of the belt tensioners

If the vehicle overturns, the sidebags are generally not deployed. Sidebags are deployed if the system detects high vehicle deceleration or acceleration in a lateral direction, or also if the vehicle overturns, and the system determines that sidebag deployment can offer additional protection to that provided by the seat belt.

Windowbags

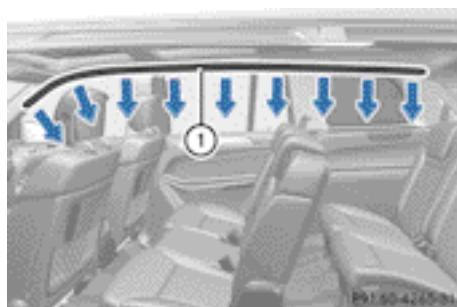

Windowbags ① enhance the level of protection for the head, but not chest or arms, of the vehicle occupants on the side of the vehicle on which the impact occurs.

The windowbags are integrated into the side of the roof frame and deploy in the area extending from the front door (A-pillar) to the rear side window (D-pillar).

Windowbags are deployed:

- at the start of an accident with a high rate of lateral vehicle deceleration or acceleration, e.g. in a side impact
- on the side on which an impact occurs
- on the driver's and the front passenger's side if the vehicle overturns and the system determines that windowbag deployment can offer additional protection to that provided by the seat belt
- independently of the use of the seat belt
- regardless of whether the front-passenger seat is occupied
- independently of the front airbags

PRE-SAFE® (preventative occupant protection)

WARNING

When adjusting the seat, make sure that nobody can become trapped.

- ❗ Make sure that there are no objects in the footwell or behind the seats when moving

the seat back. There is a risk that the seats and/or the objects could be damaged.

PRE-SAFE® takes pre-emptive measures to protect occupants in certain hazardous situations.

PRE-SAFE® intervenes:

- if BAS activates, e.g. in emergency braking situations
- if BAS PLUS intervenes powerfully – on vehicles with DISTRONIC PLUS
- if, on vehicles with DISTRONIC PLUS, the radar sensor system detects an imminent danger of collision in certain situations
- in critical driving situations, e.g. when physical limits are exceeded and the vehicle understeers or oversteers severely

PRE-SAFE® takes the following measures depending on the hazardous situation detected:

- the front seat belts are pre-tensioned.
- vehicles with the memory function: the front-passenger seat is adjusted if it is in an unfavourable position.
- vehicles with a multicontour seat: the air pressure in the side bolsters of the backrest is increased.
- if the vehicle skids, the sliding sunroof/panorama sliding sunroof and the side windows are closed so that only a small gap remains.

If the hazardous situation passes without resulting in an accident, PRE-SAFE® slackens the belt pretensioning. On vehicles with multicontour seats, the air pressure in the side bolsters is reduced again. All settings made by PRE-SAFE® can then be reversed.

If the seat belts are not released:

- ▶ Move the backrest or seat back slightly, but only when the vehicle is stationary. The belt pretensioning is reduced and the locking mechanism is released.

More information about seat belt adjustment, a convenience function integrated into PRE-

SAFE®, can be found in the "Seat belt adjustment" section (▷ page 48).

Seat belts

Important safety notes

WARNING

A seat belt which is not worn correctly, or which has not been engaged in the seat belt buckle correctly, cannot provide the intended level of protection. Under certain circumstances, this could cause severe or even fatal injuries in the event of an accident.

Therefore, make sure that all occupants – in particular, pregnant women – wear their seat belts correctly at all times.

- The seat belt must fit snugly on your body and must not be twisted. Therefore, avoid wearing bulky clothing, e.g. a winter coat. The shoulder section of the belt must be routed across the centre of your shoulder – on no account across your neck or under your arm – and pulled tight against your upper body. The lap belt must always pass across your lap as low down as possible, i.e. over your hip joints – not across your abdomen. If necessary, push the seat belt slightly downwards and adjust it by pulling it in the direction the seat belt retracts.
- Do not route the seat belt strap over sharp or fragile objects. Please make sure that such objects are not on or in your clothing, e.g. spectacles, pens or keys etc. The seat belt strap could become damaged and tear during an accident and you or other vehicle occupants could be injured.
- Only one person should use each seat belt at any one time. Children must never travel sitting on the lap of another occupant. The child will not be secured in the event of an accident, heavy braking or sudden change of direction. This may result in the child or other occupants being seriously or fatally injured.

- Persons under 1.50 m tall cannot wear the seat belts correctly. For this reason secure persons less than 1.50 m tall in specially designed, suitable restraint systems.
- Children under 1.50 m tall and younger than twelve years of age cannot wear the seat belts correctly. For this reason secure them in special suitable child restraint systems installed on a suitable seat. Additional information can be found in the Operating Instructions in the chapter "Safety", "Children in the Vehicle". Observe the installation instructions of the child restraint system manufacturer.
- Do not secure an object with a seat belt if the seat belt is also being used by one of the vehicle's occupants.

WARNING

The seat belt does not offer the intended level of protection unless the backrest is almost vertical. Under certain circumstances, this could cause severe or even fatal injuries in the event of an accident.

Before starting a journey, make sure that the seat is properly adjusted and that the backrest is almost vertical.

WARNING

A dirty or damaged seat belt or one that has been modified or subjected to a load in an accident no longer offers the intended level of protection. Under certain circumstances, this could cause severe or even fatal injuries in the event of an accident.

For this reason, check regularly that the seat belts are not damaged or dirty.

Always have damaged seat belts or seat belts that have been subjected to a load in an accident replaced at a qualified specialist workshop.

For safety reasons, Mercedes-Benz recommends that you only use seat belts which have been approved by Mercedes-Benz for your vehicle.

Seat belts are the most effective means of restraining the movement of vehicle occupants in the event of an accident. This reduces the risk of vehicle occupants coming into contact with parts of the vehicle interior.

Fastening seat belts

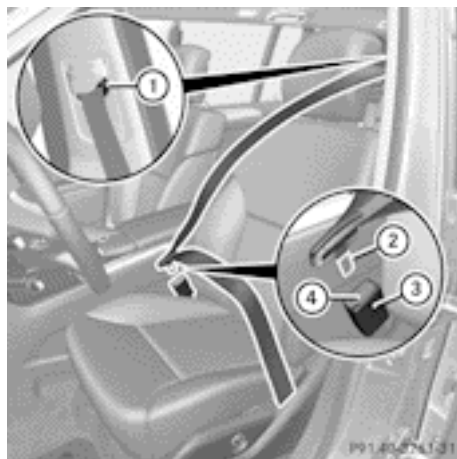

- ▶ Adjust the seat and move the backrest to an almost vertical position (▷ page 100).
- ▶ Pull the seat belt smoothly through belt sash guide ①.
- ▶ Without twisting it, guide the shoulder section of the seat belt across the middle of your shoulder and the hip section across your hips.
- ▶ Engage belt tongue ② in buckle ③.
Seat-belt adjustment: if necessary, the driver's and front-passenger seat belts automatically adjust to the upper body (▷ page 48).
- ▶ If necessary, adjust the seat belt to the appropriate height (▷ page 48).
- ▶ If necessary, pull upwards on the shoulder section of the seat belt to tighten the belt across your body.

For more information about releasing the seat belt with release button ④, see "Releasing seat belts" (▷ page 48).

Seat belt adjustment

The seat-belt adjustment function adjusts the driver's and front-passenger seat belt to the upper body of the occupants.

The belt strap is tightened slightly when:

- you engage the belt tongue in the belt buckle and you then turn the key to position **2** in the ignition lock.
- the key is in position **2** in the ignition lock and you then engage the belt tongue in the buckle.

The seat-belt adjustment will apply a certain tightening force if any slack is detected between the occupant and the seat belt. Do not hold on to the seat belt tightly while it is adjusting. You can switch the seat-belt adjustment on and off in the on-board computer (▷ page 285).

The seat-belt adjustment is an integral part of the PRE-SAFE® convenience function. More information about PRE-SAFE® can be found under "PRE-SAFE® (preventative occupant protection)" (▷ page 45).

Belt height adjustment

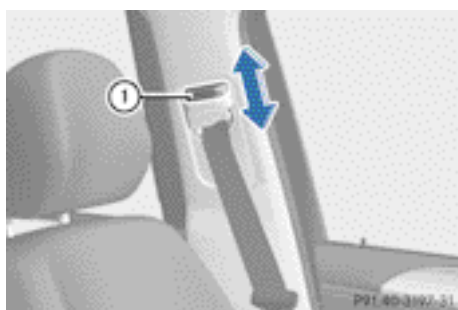

You can adjust the belt height for the front seats. Adjust the belt to a height that allows the upper part of the seat belt to be routed across the centre of your shoulder.

- ▶ **To raise:** slide the belt sash guide upwards. The belt sash guide engages in various positions.
- ▶ **To lower:** press and hold belt sash guide release ①.

- ▶ Slide the belt sash guide downwards.
- ▶ Let go of belt sash guide release ① and make sure that the belt sash guide has engaged.

Releasing the seat belts

- ⚠ Make sure that the seat belt is fully rolled up. Otherwise, the seat belt or belt tongue will be trapped in the door or in the seat mechanism. This could damage the door, the door trim panel and the seat belt. Damaged seat belts can no longer fulfil their protective function and must be replaced. Visit a qualified specialist workshop.

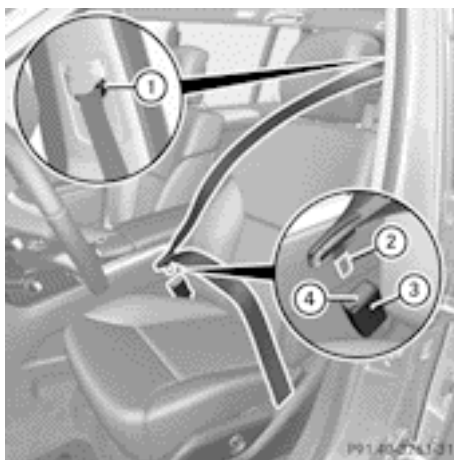

- ① Belt sash guide
- ② Belt tongue
- ③ Buckle
- ④ Release button

- ▶ Press release button ④ and guide belt tongue ② back towards belt sash guide ①.

Belt warning for the driver and front passenger

The  seat belt warning lamp in the instrument cluster is a reminder for all occupants to fasten their seat belts. It may light up con-

tinuously or flash. In addition, there may be a warning tone.

The  seat belt warning lamp goes out and the warning tone ceases when the driver and the front passenger have fastened their seat belt.



For certain countries only: regardless of whether the driver and the front passenger have fastened their seat belts, the  seat belt warning lamp lights up for six seconds after the engine is started. It then goes out if the driver and the front passenger have fastened their seat belts.

- i** For more information on the  seat belt warning lamp, see "Indicator and warning lamps in the instrument cluster, seat belt" (▷ page 325).

Rear seat belt status indicator



Example: rear-compartment seat belt status indicator

The rear-compartment seat belt status indicator indicates the rear seat on which the belt is fastened. The status indicator displays people in the direction of travel. In the example, the passengers on the outer seats in the rear have their seat belts fastened. The  symbol in the multifunction display indicates a fastened seat belt. If a seat belt is not fastened or if a seat is not occupied, the  symbol is displayed.

The rear-compartment seat belt status indicator appears in the multifunction display for around 30 seconds if:

- you drive off and reach a speed of approximately 10 km/h.
- the rear passengers fasten or unfasten their seat belts while the vehicle is in motion.
- someone gets in or out of the vehicle and the vehicle drives off again.

You can also cancel the rear seat belt status indicator immediately (▷ page 290).

- i** The status indicator for the rear-compartment seat belts is only available for certain countries.

Belt tensioners, belt force limiters

WARNING

If the seat belt tensioners have been triggered, they provide no additional protection in the event of another accident. Therefore, have belt tensioners which have been triggered replaced at a qualified specialist workshop.

Comply with safety regulations when disposing of belt tensioners. Any Mercedes-Benz Service Centre can provide details of these regulations.

- !** If the front-passenger seat is not occupied, do not engage the seat belt tongue in the buckle on the front-passenger seat. Otherwise, the belt tensioner could be triggered in the event of an accident.
- In order to ensure that the pyrotechnic seat belt tensioners have not been triggered, always have the seat belts checked after an accident. If the belt tensioners have been triggered, they must be replaced.

The seat belts on the following seats have belt tensioners and belt force limiters:

- driver's and front-passenger seat
- the outer seats in the second row
- the seats in the third row

The belt tensioners tighten the seat belts in an accident, pulling them close against the body.

Belt tensioners do not correct incorrect seat positions or incorrectly fastened seat belts.

Belt tensioners do not pull vehicle occupants back towards the backrest.

If the seat belt is also fitted with a belt force limiter and this is triggered, the force exerted by the seat belt on the vehicle occupant is reduced.

The belt force limiters for the front seats are synchronised with the front airbags, which take on a part of the deceleration force. This results in the force exerted on the occupant being distributed over a greater area.

The belt tensioners can only be activated when:

- the ignition is switched on.
- the restraint systems are operational; see "SRS warning lamp" (> page 41).

The belt tensioners on the outside seats in the second row and on the seats in the third row are triggered independently of the lock status of the seat belts.

The belt tensioners are triggered depending on the type and severity of an accident:

- if, in the event of a head-on or rear-end collision, the vehicle decelerates or accelerates rapidly in a longitudinal direction during the initial stages of the impact
- if, in the event of a side impact, on the side opposite the impact the vehicle decelerates or accelerates rapidly in a lateral direction
- in certain situations where the vehicle overturns and the system determines that it can provide additional protection

If the airbags are deployed, you will hear a bang, and a small amount of powder may also be released. Only in rare cases will the bang affect your hearing. The powder that is released generally does not constitute a health hazard. The  SRS warning lamp lights up.

Children in the vehicle

Child restraint systems

Important safety notes

WARNING

To reduce the risk of serious or even fatal injury to the child in the event of a sudden change in direction, braking or an accident:

- children less than 1.50 m tall and under twelve years of age must always be secured in special child restraint systems on a suitable vehicle seat. This is necessary because the seat belts are not designed for children.
- Do not drive with a child secured in a rearward-facing child restraint system on the front-passenger seat. Exception: if the vehicle is equipped with automatic child seat recognition on the front-passenger seat and the child is secured in a child restraint system with transponders for automatic child seat recognition
- if you secure a forward-facing child restraint system to the front-passenger seat, you must move the front-passenger seat as far back as possible.
- children must never travel sitting on the lap of another occupant. Due to the forces which occur in the event of a sudden change of direction, heavy braking or an accident, it would not be possible to restrain the child. The child could be thrown against parts of the vehicle interior and be seriously or even fatally injured.

⚠ WARNING

Do not leave children unsupervised in the vehicle, even if they are secured in a child restraint system. They could injure themselves on parts of the vehicle. They could also be seriously or even fatally injured by prolonged exposure to extreme heat or cold.

Do not expose the child restraint system to direct sunlight. Parts of the child restraint system could heat up and the child could burn herself/himself on them.

If a child opens a door, the child or other persons could be injured as a result. They could get out and injure themselves or be injured by a passing vehicle.

Observe the general notes on the HOLD function, which can be found under the same keyword.

⚠ WARNING

Unsecured or incorrectly positioned loads increase the risk of injury for children and all other occupants in the event of:

- an accident
- sudden braking
- a sudden change of direction

Do not transport heavy or hard objects in the vehicle interior unless they are secured. You will find further information under "Loading guidelines" in the index.

If a child is travelling in your vehicle, secure the child using a child restraint system that is recommended for Mercedes-Benz vehicles. The child restraint system must be appropriate to the age, weight and size of the child. You should preferably fit the child restraint system to a suitable rear seat. Make sure that the child is secured for the trip.

Mercedes-Benz recommends that you use the listed child restraint systems (> page 58). You can obtain further information about the correct child restraint system from any Mercedes-Benz Service Centre.

- i** It is advisable to use Mercedes-Benz care products to clean child restraint systems. You can obtain information about this at any Mercedes-Benz Service Centre.

Child restraint system on the front-passenger seat**⚠ WARNING**

If the front-passenger airbag is not disabled:

- a child secured in a child restraint system on the front-passenger seat could be seriously and even fatally injured by the front-passenger airbag deploying. This is especially a risk if the child is in the immediate vicinity of the front-passenger airbag when it deploys.
- never secure a child on the front-passenger seat in a rearward-facing child restraint system. Only secure a rearward-facing child restraint system on a suitable rear seat.
- always move the front-passenger seat to the rearmost position if you secure a child in a forward-facing child restraint system on the front-passenger seat.

The front-passenger airbag is not disabled:

- on vehicles without automatic child seat recognition on the front-passenger seat
- in vehicles with automatic child seat recognition in the front-passenger seat, if no special child restraint system with transponders for automatic child seat recognition in the front-passenger seat has been fitted
- on vehicles with automatic child seat recognition on the front-passenger seat, if the PASSENGER AIRBAG OFF indicator lamp  is not lit.

To make you aware of this danger, a corresponding warning sticker has been affixed on the dashboard and on both sides of the sun visor on the front-passenger side.

Information about recommended child restraint systems is available at any Mercedes-Benz Service Centre.



Warning notice on the front-passenger sun visor



Warning symbol for a rearward-facing child restraint system

Do not use a rearward-facing child restraint system on a seat that is protected by an airbag installed in front of it.

Automatic child seat recognition on the front-passenger seat

WARNING

If the  PASSENGER AIRBAG OFF indicator lamp does not light up when the child restraint system is fitted, the front-passenger airbag has not been disabled. If the front-passenger airbag deploys, the child could be seriously or even fatally injured.

Proceed as follows:

- do not use a rearward-facing child restraint system on the front-passenger seat.
- fit a rearward-facing child restraint system on a suitable rear seat.

or



- only use a forward-facing child restraint system on the front-passenger seat and move the front-passenger seat to the rear-most position.
- have the automatic child seat recognition checked at a qualified specialist workshop.

To ensure that the automatic child seat recognition on the front-passenger seat functions/communicates correctly, never place objects, e.g. a cushion, under the child restraint system. The entire base of the child restraint system must always rest on the seat cushion. An incorrectly fitted child restraint system cannot perform its intended protective function in the event of an accident, and could lead to injuries.

WARNING

Do not place electronic devices on the front-passenger seat, e.g.:

- laptops, when switched on
- mobile phones
- cards with transponders, e.g. ski passes or access cards

Signals from electronic equipment can cause interference in the automatic child seat recognition sensor system. This can lead to a system malfunction. This may cause the  PASSENGER AIRBAG OFF indicator lamp to light up without there being a child seat with transponders for automatic child seat recognition fitted. The front-passenger airbag will not then deploy during an accident. It is also possible that the  SRS warning lamp lights up and/or the  PASSENGER AIRBAG OFF indicator lamp does not light up briefly when you turn the key in the ignition lock to position **2**.



If the front-passenger seat of your vehicle does not have automatic child seat recognition, this is indicated by a special sticker. The sticker is affixed to the side of the dashboard on the front-passenger side. The sticker is visible when you open the front-passenger door.

Vehicles without automatic child seat recognition on the front-passenger seat: if you turn the key to position 2 in the ignition lock, the PASSENGER AIRBAG OFF  indicator lamp lights up briefly. It has no function, however, and does not indicate that the front-passenger seat is equipped with automatic child seat recognition.



The front-passenger seat sensor system for child restraint systems detects whether a special Mercedes-Benz child seat with a transponder for automatic child seat recognition has been fitted. In this case,  PASSENGER AIRBAG OFF indicator lamp ① lights up. The front-passenger front airbag is disabled.

i If the front-passenger front airbag is disabled by the automatic child seat recognition, the following remain enabled on the front-passenger side:

- the sidebag
- the windowbag
- the belt tensioner

ISOFIX child seat securing system for the rear seats

⚠ WARNING

A child restraint system secured by the ISOFIX child seat securing system does not provide sufficient protection for children weighing more than 22 kg. For this reason, do not secure children weighing more than 22 kg in a child restraint system secured by the ISOFIX child seat securing system. If the child weighs more than 22 kg, secure the child restraint system with the vehicle seat belt as well. In addition, when fitting a child restraint system, be sure to observe the manufacturer's installation instructions and the instructions for correct use of the child restraint system.

⚠ WARNING

The child restraint system cannot perform its protective function if it is not correctly fitted to a suitable vehicle seat. The child cannot be restrained in the event of an accident, heavy braking or sudden changes of direction. The child could be seriously or even fatally injured. For this reason, when fitting a child restraint system, be sure to observe the manufacturer's installation instructions and the instructions for correct use of the child restraint system.

For safety reasons, when installing child restraint systems on the outer rear seats, only use child restraint systems with the ISOFIX child seat securing system, which are specially tested and approved for Mercedes-Benz vehicles.

An incorrectly fitted child restraint system could come loose and seriously or even fatally

injure the child or other vehicle occupants. When fitting the child restraint system, always make sure that it is engaged correctly in the securing rings on both sides.

To ensure that the child restraint system can perform its protective function as intended, the backrest of the outer seat in the second row must be in the upright position.

WARNING

Please note that if child restraint systems, or their retaining systems, are damaged or subjected to a load in an accident, they may not be able to provide their protective function. This could result in serious or even fatal injuries to the secured child in the event of an accident, heavy braking or a sudden change in direction.

For this reason, have child restraint systems and their anchorages which have been damaged or subjected to a load in an accident checked immediately at a qualified specialist workshop.

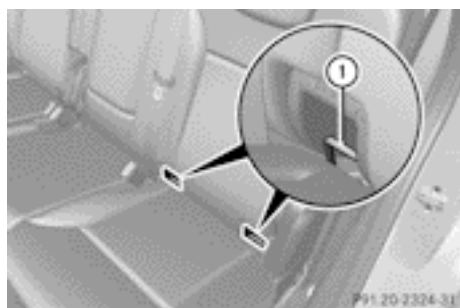

Securing rings for the outer seats in the second row

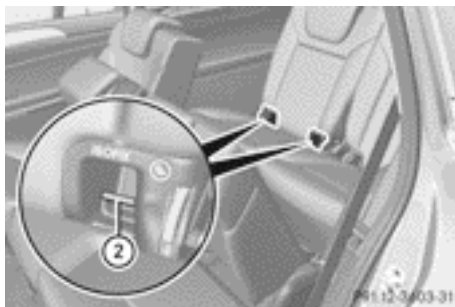

Securing rings for the third row of seats

Securing rings ① and ② for two ISOFIX child restraint systems can be found on the left and right:

- on the rear seat backrests of the outer seats in the second row
- on the backrests of the seats in the third row of seats.

Before installing an ISOFIX child restraint system in the second row:

- ▶ Move the rear seat backrests in the second row to an upright position (▷ page 104).
- ▶ Install the ISOFIX child restraint system. Comply with the manufacturer's instructions when installing the ISOFIX child restraint system.

Top Tether

Top Tether anchorages

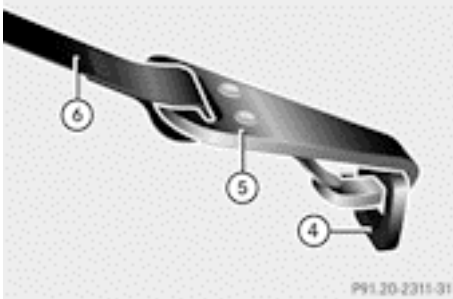
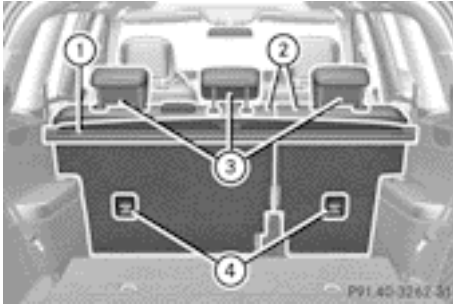

Top Tether provides an additional connection between the child restraint system secured with ISOFIX and the rear seat. It helps reduce the risk of injury even further.







The Top Tether anchorages for the second row of seats are located on the rear of both outer rear seat backrests. For the third row of seats, use the lashing eyelets in the luggage compartment floor.

- ▶ Move head restraint ③ upwards.
- ▶ Fit the ISOFIX child restraint system with Top Tether. Comply with the manufacturer's installation instructions when doing so.
- ▶ Route Top Tether belt ⑥ under head restraint ③ between the two head restraint bars.
- ▶ Guide Top Tether belt ⑥ downwards between luggage compartment cover ① and rear seat backrest ②.
- ▶ Hook Top Tether hook ⑤ of Top Tether belt ⑥ into Top Tether anchorage ④.

Ensure that:

- Top Tether hook ⑤ is hooked into Top Tether anchorage ④ as shown.
 - Top Tether belt ⑥ is not twisted.
 - Top Tether belt ⑥ is routed between rear seat backrest ② and luggage compartment cover ① if luggage compartment cover is fitted.
 - Top Tether belt ⑥ is routed between the rear seat backrest ② and the safety net if the safety net is fitted.
- ▶ Tension Top Tether belt ⑥. Comply with the manufacturer's installation instructions when doing so.
- ▶ Move head restraint ③ back down again slightly if necessary (▷ page 103). Make sure that you do not interfere with the correct routing of Top Tether belt ⑥.

Problems with automatic child seat recognition

Problem	Possible causes/consequences and ► Solutions
The  PASSENGER AIRBAG OFF indicator lamp on the centre console is lit.	A special Mercedes-Benz child seat with a transponder for automatic child seat recognition has been fitted to the front-passenger seat. The front-passenger front airbag has therefore been disabled as desired.
The  PASSENGER AIRBAG OFF indicator lamp on the centre console is lit. or The  warning lamp lights up and/or the  PASSENGER AIRBAG OFF indicator lamp does not light up briefly when you switch the ignition on.	<p> WARNING</p> <p>There is no child seat fitted to the front-passenger seat. Automatic child seat recognition is malfunctioning. There is a risk of injury.</p> <p>► Remove electronic equipment from the front-passenger seat, e.g.:</p> <ul style="list-style-type: none"> • laptop • mobile phone • cards with transponders, such as ski passes or access cards <p>If the  PASSENGER AIRBAG OFF indicator lamp is still lit:</p> <p>► Visit a qualified specialist workshop.</p>

Suitable positioning of the child restraint systems

- If you fit a child restraint system to the front-passenger seat, position the front-passenger seat in its rearmost position.
- If you install a child restraint system on the rear seat on the second row, move the rear seat backrests in the second row to an upright position.

Key to the letters used in the following table:

- X Seat which is unsuitable for children in this weight category.
- U Suitable for child restraint systems in the "Universal" category that are approved for use in this weight category.
- L Suitable for child restraint systems as recommended; see the following table of "Recommended child restraint systems" (> page 58).

Front-passenger seat

Weight categories	Front-passenger front air-bag is not disabled.	Front-passenger front air-bag is disabled.
Category 0: up to 10 kg	X	U
Category 0+: up to 13 kg	X	U
Category I: 9 to 18 kg	L	U
Category II: 15 to 25 kg	L	L
Category III: 22 to 36 kg	L	L

Vehicles with automatic child seat recognition in the front-passenger seat: a "Universal" category child restraint system with a transponder for automatic child seat recognition must be fitted when the front-passenger airbag is disabled. The  PASSENGER AIRBAG OFF indicator lamp must be lit.

Rear seats

Weight categories	Third row of seats, left and right	Centre
Category 0: up to 10 kg	U	X
Category 0+: up to 13 kg	U	X
Category I: 9 to 18 kg	U	L
Category II: 15 to 25 kg	U	L
Category III: 22 to 36 kg	U	L

"Universal" category child restraint systems can be recognised by their orange approval label.



Example: approval label on the child restraint system

Suitability of the rear seats for attaching ISOFIX child restraint systems

Key to the letters used in the following table:

- X ISOFIX position that is not suitable for ISOFIX child restraint systems in this weight category and/or size category.
- IUF Suitable for forward-facing ISOFIX child restraint systems that belong to the "Universal" category which are approved for use in this weight category.
- IL Suitable for ISOFIX child restraint systems as recommended; see the following table of "Recommended child restraint systems" (▷ page 58).

Carry-cot weight category

Size category	Equipment	Rear seat, left and right
F	ISO/L1	X
G	ISO/L2	X

Weight category 0: up to 10 kg, up to approximately 6 months

Size category	Equipment	Rear seat, left and right
E	ISO/R1	IL

Weight category 0+: up to 13 kg, up to approximately 15 months

Size category	Equipment	Rear seat, left and right
E	ISO/R1	IL
D	ISO/R2	IL
C	ISO/R3	IL

Weight category I: 9 to 18 kg, approximately 9 months to 4 years

Size category	Equipment	Rear seat, left and right
D	ISO/R2	IL
C	ISO/R3	IL
B	ISO/F2	IUF
B1	ISO/F2X	IUF
A	ISO/F3	IUF

Recommended child restraint systems

When installing a child restraint system without a transponder for automatic child seat recognition on the front-passenger seat:

- Move the front-passenger seat to its highest and rearmost position.

Weight category 0: up to 10 kg, up to approximately 6 months

Manufacturer	Britax Römer
Type	BABY SAFE PLUS
Approval number (E1 ...)	03 301146 04 301146
Order number (A 000 ...)	970 10 00
Automatic child seat recognition	Yes

Weight category 0+: up to 13 kg, up to approximately 15 months

Manufacturer	Britax Römer
Type	BABY SAFE PLUS
Approval number (E1 ...)	03 301146 04 301146

Order number (A 000 ...)	970 10 00
Automatic child seat recognition	Yes

Weight category I: 9 to 18 kg, approximately 9 months to 4 years

Manufacturer	Britax Römer	Britax Römer
Type	DUO PLUS	DUO PLUS
Approval number (E1 ...)	03 301133 04 301133	03 301133 04 301133
Order number (A 000 ...)	970 11 00	970 16 00
Automatic child seat recognition	Yes	No

Weight category II/III: 15 to 36 kg, approximately 4 to 12 years

Manufacturer	Britax Römer	Britax Römer
Type	KID	KID
Approval number (E1 ...)	03 301148 04 301148	03 301148 04 301148
Order number (A 000 ...)	970 12 00	970 17 00
Automatic child seat recognition	Yes	No

Suggested "Universal" category ISOFIX child restraint systems:

Carry-cot weight category

Size categories	F, G
Manufacturer	–
Type	–
Approval number (E1 ...)	–
Order number	–
Automatic child seat recognition	–

Category 0: up to 10 kg

Size category	E
Manufacturer	–
Type	–
Approval number (E1 ...)	–
Order number	–
Automatic child seat recognition	–

Category 0+: up to 13 kg

Size categories	E	D, C
Manufacturer	Britax Römer	–
Type	BABY SAFE ISOFIX PLUS	–
Approval number (E1 ...)	04 301146	–
Order number	B6 6 86 8224	–
Automatic child seat recognition	No	–

Category I: 9 to 18 kg

Size categories	D, C, B, A
Manufacturer	–
Type	–
Approval number (E1 ...)	–
Order number	–
Automatic child seat recognition	–

Size category	B1
Manufacturer	Britax Römer
Type	DUO PLUS
Approval number (E1 ...)	03 301133 04 301133
Order number	A000 970 11 00
Automatic child seat recognition	Yes

Child-proof locks

Important safety notes

 **WARNING**

Activate the child-proof locks for the rear doors and the override switch for the rear windows when children are travelling in the vehicle. Otherwise, the children could open doors or side windows while the vehicle is in motion and injure themselves or others.

 **WARNING**

Do not leave children unsupervised in the vehicle, even if they are secured in a child restraint system. They could injure themselves on parts of the vehicle. They could also be seriously or even fatally injured by prolonged exposure to extreme heat or cold.

Do not expose the child restraint system to direct sunlight. Parts of the child restraint system could heat up and the child could burn herself/himself on them.

If a child opens a door, the child or other persons could be injured as a result. They could get out and injure themselves or be injured by a passing vehicle.

Also observe the notes on HOLD. Relevant information can be found in the index.

Child-proof locks for the rear doors

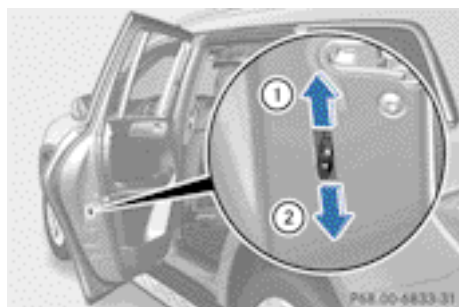

You secure each door individually with the child-proof locks on the rear doors. A door secured with a child-proof lock cannot be opened from inside the vehicle. When the vehicle is unlocked, the door can be opened from the outside.

- ▶ **To activate:** press the child-proof lock lever down in the direction of arrow ②.
- ▶ Make sure that the child-proof locks are working properly.
- ▶ **To deactivate:** press the child-proof lock lever up in the direction of arrow ①.

Override feature for the rear side windows

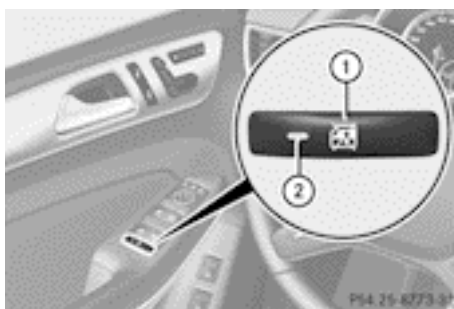

- ▶ **To activate/deactivate:** press button ①. If indicator lamp ② is lit, operation of the rear side windows is disabled. Operation is only possible using the switches in the driver's door. If indicator lamp ② is off, operation is possible using the switches in the rear compartment.

Driving safety systems

Driving safety systems overview

In this section, you will find information about the following driving safety systems:

- ABS (Anti-lock Braking System) (▷ page 61)
- BAS (Brake Assist System) (▷ page 62)
- BAS PLUS (Brake Assist System Plus) (▷ page 62)
- COLLISION PREVENTION ASSIST (▷ page 63)
- Adaptive brake lamps (▷ page 65)
- ESP® (Electronic Stability Program) (▷ page 66)
- EBD (Electronic Brake force Distribution) (▷ page 68)
- ADAPTIVE BRAKE (▷ page 68)
- PRE-SAFE® Brake (▷ page 68)
- STEER CONTROL (▷ page 70)

Important safety notes

If you fail to adapt your driving style or become distracted, the driving safety systems can neither reduce the risk of accident nor override the laws of physics. Driving safety systems are merely aids designed to assist driving. You are responsible for the distance to the vehicle in front, for vehicle speed and for braking in good time. Always adapt your driving style to suit the prevailing road and weather conditions and maintain a safe distance from the vehicle in front. Drive carefully.

- i** The driving safety systems described only work as effectively as possible when there is adequate contact between the tyres and the road surface. Please pay special attention to the notes on tyres, recommended minimum tyre tread depths, etc. (▷ page 396).

In wintry driving conditions, always use winter tyres (M+S tyres) and if necessary, snow chains. Only in this way will the driving safety systems described in this section work as effectively as possible.

ABS (Anti-lock Braking System)

Important safety notes

- i** Observe the "Important safety notes" section (▷ page 61).

WARNING

If ABS is faulty, the wheels could lock when braking. The steerability and braking characteristics may be severely impaired. Additionally, further driving safety systems are deactivated. There is an increased danger of skidding and accidents.

Drive on carefully. Have ABS checked immediately at a qualified specialist workshop.

When ABS is malfunctioning, other systems, including driving safety systems, will also become inoperative. Observe the information

on the ABS warning lamp (▷ page 326) and display messages which may be shown in the instrument cluster (▷ page 291).

ABS regulates brake pressure in such a way that the wheels do not lock when you brake. This allows you to continue steering the vehicle when braking.

ABS works from a speed of about 8 km/h upwards, regardless of road-surface conditions. ABS works on slippery surfaces, even when you only brake gently.

The yellow  ABS warning lamp in the instrument cluster lights up when the ignition is switched on. It goes out when the engine is running.

Brakes

► **If ABS intervenes:** continue to depress the brake pedal with force until the braking situation is over.

► **To make a full brake application:** depress the brake pedal with full force.

If ABS intervenes when braking, you will feel a pulsing in the brake pedal.

The pulsating brake pedal can be an indication of hazardous road conditions, and functions as a reminder to take extra care while driving.

Off-road ABS

An ABS system specifically suited to off-road terrain is activated automatically once the off-road program is activated on:

- Vehicles without the ON&OFFROAD package (▷ page 252)
- Vehicles with the ON&OFFROAD package (▷ page 253)

At speeds below 30 km/h, the front wheels lock cyclically during braking. The digging-in effect achieved in the process reduces the stopping distance when driving off-road. This limits steering capability.

BAS (Brake Assist System)

i Observe the "Important safety notes" section (▷ page 61).

⚠ WARNING

If BAS is malfunctioning, the braking distance in an emergency braking situation is increased. There is a risk of accident.

In an emergency braking situation, depress the brake pedal with full force. ABS prevents the wheels from locking.

BAS operates in emergency braking situations. If you depress the brake pedal quickly, BAS automatically boosts the braking force, thus shortening the stopping distance.

The brakes will function as usual once you release the brake pedal. BAS is deactivated.

BAS PLUS (Brake Assist System Plus)

i Observe the "Important safety notes" section (▷ page 61).

BAS PLUS is only available on vehicles with DISTRONIC PLUS.

BAS PLUS provides braking assistance in hazardous situations at speeds greater than 7 km/h and uses radar sensor technology to assess the traffic situation.

With the help of the radar sensor system, BAS PLUS can detect obstacles that are in the path of your vehicle for an extended period of time.

At speeds up to approximately 70 km/h, BAS PLUS may also detect stationary obstacles, for example, stopped or parked vehicles.

To prevent a front-end collision, BAS PLUS calculates the brake force necessary if:

- you approach an obstacle, and
- BAS PLUS has detected a risk of collision

If you are driving at a speed over 30 km/h: if you depress the brake sharply, BAS PLUS automatically raises the brake pressure to a value adapted to the traffic situation.

If you are driving at a speed under 30 km/h: if you depress the brake, BAS PLUS is activated. Braking will be carried out at the last possible moment.

If BAS PLUS demands particularly high braking force, preventative passenger protection measures (PRE-SAFE®) are activated simultaneously.

- ▶ Keep the brake pedal depressed until the emergency braking situation is over. ABS prevents the wheels from locking.

BAS PLUS is deactivated and the brakes function as usual, if:

- you release the brake pedal.
- there is no longer any danger of a rear-end collision.
- no obstacle is detected in front of your vehicle.

If you have activated DSR (▷ page 251), BAS PLUS is also deactivated.

The radar sensor system is switched off automatically in the vicinity of radio telescope facilities in the following vehicles:

- vehicles with COMAND Online and navigation
- vehicles with Audio 20 and Becker® MAP PILOT
Becker® MAP PILOT must be connected; see the separate operating instructions.

The radar sensor system must be switched off using the on-board computer in the vicinity of radio telescope facilities in the following vehicles:

- vehicles without COMAND Online and navigation
- vehicles without Audio 20 and Becker® MAP PILOT
- vehicles for Australia

For information on switching off the radar sensor system using the on-board computer, see (▷ page 283).

For BAS PLUS to assist you when driving, the radar sensor system must:

- be switched on (▷ page 283)
- be operational (▷ page 298)

If the radar sensor system is malfunctioning, BAS PLUS will not be available. The brake system is still available with complete brake boosting effect and BAS.

WARNING

BAS PLUS cannot always clearly identify objects and complex traffic situations. BAS PLUS cannot intervene in these cases. There is a risk of an accident.

Always pay careful attention to the traffic situation and be ready to brake.

In particular, the detection of obstacles can be impaired if there is:

- dirt on the sensors or anything else covering the sensors
- snow or heavy rain
- interference by other radar sources
- the possibility of strong radar reflections, for example, in multi-storey car parks
- a narrow vehicle travelling in front, e.g. a motorcycle
- a vehicle travelling in front on a different line

WARNING

BAS PLUS does not react:

- to people or animals
- to oncoming vehicles
- to crossing traffic
- when cornering

As a result, BAS PLUS may not intervene in all critical situations. There is a risk of an accident.

Always pay careful attention to the traffic situation and be ready to brake.

Following damage to the front end of the vehicle, have the configuration and operation of the radar sensors checked at a qualified spe-

cialist workshop. This also applies to collisions at slow speeds where there is no visible damage to the front of the vehicle.

COLLISION PREVENTION ASSIST

General notes

COLLISION PREVENTION ASSIST consists of Adaptive Brake Assist and the distance warning function, which are described in the following.

Distance warning function

Important safety notes

-  Observe the "Important safety notes" section (▷ page 61).

WARNING

The distance warning function does not react:

- to people or animals
- to oncoming vehicles
- to crossing traffic
- when cornering

Thus, the distance warning function cannot provide a warning in all critical situations. There is a risk of an accident.

Always pay careful attention to the traffic situation and be ready to brake.

The distance warning function cannot always clearly identify objects and complex traffic situations.



In such cases, the distance warning signal may:

- give an unnecessary warning
- not give a warning

Always pay careful attention to the traffic situation, do not rely on the distance warning function alone.



Function

- ▶ **To activate/deactivate:** activate or deactivate the distance warning function in the on-board computer (▷ page 278).

When the distance warning function is activated, the multifunction display shows the  symbol as long as the HOLD function is not activated (▷ page 211). On vehicles with Active Parking Assist, the  symbol is displayed when position **P** is engaged or you are driving faster than 35 km/h.

The distance warning function can help you to minimise the risk of a collision with the vehicle in front or reduce the effects of such a collision. If the distance warning function detects that there is a risk of a collision, you will be warned visually and acoustically. The distance warning function cannot prevent a collision without your intervention.

The distance warning function will issue a warning at speeds of around 30 km/h or more if:

- the distance to the vehicle in front is too short for the speed you are driving at for several seconds. The  distance warning lamp then lights up in the instrument cluster.
 - you are rapidly approaching the vehicle in front. An intermittent warning tone will then sound and the  distance warning lamp will light up in the instrument cluster.
- ▶ Brake immediately in order to increase the distance from the vehicle in front.

or

- ▶ Take evasive action provided it is safe to do so.

For the distance warning function to assist you when driving, the function must be activated in the on-board computer and be operational (▷ page 278).

Due to the nature of the system, particularly complicated driving conditions may cause the system to display an unnecessary warning.

With the help of the radar sensor system, the distance warning function can detect obstacles that are in the path of your vehicle for an extended period of time.

At speeds up to approximately 70 km/h, the distance warning function may also detect

stationary obstacles, for example, stopped or parked vehicles.

If you approach an obstacle and the distance warning function detects a risk of a collision, the system will initially alert you both visually and acoustically.

In particular, the detection of obstacles can be impaired if there is:

- dirt on the sensors or anything else covering the sensors
- snow or heavy rain
- interference by other radar sources
- the possibility of strong radar reflections, for example, in multi-storey car parks
- a narrow vehicle travelling in front, e.g. a motorcycle
- a vehicle travelling in front on a different line

Following damage to the front end of the vehicle, have the configuration and operation of the radar sensor checked at a qualified specialist workshop. This also applies to collisions at slow speeds where there is no visible damage to the front of the vehicle.

Adaptive Brake Assist

-  Observe the "Important safety notes" section (▷ page 61).

WARNING

Adaptive Brake Assist cannot always clearly identify objects and complex traffic situations. In these cases, Adaptive Brake Assist may not intervene. There is a risk of an accident.

Always pay careful attention to the traffic situation and be ready to brake.

WARNING

Adaptive Brake Assist does not react:

- to people or animals
- to oncoming vehicles
- to crossing traffic

- to stationary obstacles
- when cornering

As a result, Adaptive Brake Assist may not intervene in all critical conditions. There is a risk of an accident.

Always pay careful attention to the traffic situation and be ready to brake.

Adaptive Brake Assist aids you in braking during hazardous situations at speeds above 30 km/h and uses the radar sensor system to evaluate the traffic situation.

With the help of the adaptive Brake Assist, the distance warning signal can detect obstacles that are in the path of your vehicle for an extended period of time.

Should you approach an obstacle and the adaptive Brake Assist has detected a risk of collision, the adaptive Brake Assist calculates the braking force necessary to avoid a collision with the vehicle in front. Should you apply the brakes forcefully, the adaptive Brake Assist will automatically increase the braking force to a level suitable for the traffic conditions.

- ▶ Keep the brake pedal depressed until the emergency braking situation is over. ABS prevents the wheels from locking.

The brakes will work normally again if:

- you release the brake pedal.
- there is no longer any danger of a rear-end collision.
- no obstacle is detected in front of your vehicle.

Adaptive Brake Assist is then deactivated.

If adaptive Brake Assist demands particularly high braking force, preventative passenger protection measures (PRE-SAFE®) are activated simultaneously.

Up to vehicle speeds of around 250 km/h, the adaptive Brake Assist is capable of reacting to moving objects that have already been recognised as such at least once over the period of observation. Adaptive Brake Assist does not react to stationary obstacles.

If the adaptive Brake Assist is not available due to a malfunction in the radar sensor system, the brake system remains available with full brake boosting effect and BAS.

In particular, the detection of obstacles can be impaired if there is:

- dirt on the sensors or anything else covering the sensors
- snow or heavy rain
- interference by other radar sources
- the possibility of strong radar reflections, for example, in multi-storey car parks
- a narrow vehicle travelling in front, e.g. a motorcycle
- a vehicle travelling in front on a different line

Following damage to the front end of the vehicle, have the configuration and operation of the radar sensor checked at a qualified specialist workshop. This also applies to collisions at slow speeds where there is no visible damage to the front of the vehicle.

Adaptive brake lamps

If you brake sharply from a speed of more than 50 km/h or if braking is assisted by BAS or BAS PLUS, the brake lamps flash rapidly. In this way, traffic travelling behind you is warned in an even more noticeable manner.

If you brake sharply from a speed of more than 70 km/h to a standstill, the hazard warning lamps are activated automatically. If the brakes are applied again, the brake lamps light up continuously. The hazard warning lamps switch off automatically if you travel faster than 10 km/h. You can also switch off the hazard warning lamps using the hazard warning button (> page 122).

ESP® (Electronic Stability Program)

Important safety notes

i Observe the "Important safety notes" section (▷ page 61).

⚠ WARNING

If ESP® is malfunctioning, ESP® is unable to stabilise the vehicle. In addition, other driving safety systems are switched off. This increases the risk of skidding and an accident.



Drive on carefully. Have ESP® checked at a qualified specialist workshop.

! Only operate the vehicle for a maximum of ten seconds on a brake dynamometer. Switch off the ignition.

Application of the brakes by ESP® may otherwise destroy the brake system.

! A function or performance test should only be carried out on a twin-axle dynamometer. Before you operate the vehicle on such a dynamometer, please consult a qualified workshop. You could otherwise damage the drive train or the brake system.

ESP® is deactivated if the  warning lamp in the instrument cluster lights up continuously when the engine is running.

If the  warning lamp and the  warning lamp are lit continuously, ESP® is not available due to a malfunction.

Observe the information on warning lamps (▷ page 329) and display messages which may be shown in the instrument cluster (▷ page 291).

If ESP® detects that the vehicle is deviating from the direction desired by the driver, one or more wheels are braked to stabilise the vehicle. The engine output is also modified to keep the vehicle on the desired course within physical limits. ESP® assists the driver when pulling away on wet or slippery roads. ESP® can also stabilise the vehicle during braking.

If ESP® intervenes, the  ESP® warning lamp flashes in the instrument cluster.

If ESP® intervenes:

- ▶ Do not deactivate ESP® under any circumstances.
 - ▶ When pulling away, only depress the accelerator pedal as far as is necessary.
 - ▶ Adapt your driving style to suit the prevailing road and weather conditions.
- i** Only use wheels with the recommended tyre sizes. Only then will ESP® function properly.

4ETS (Electronic Traction System)

Traction control is part of ESP®.

Traction control brakes the drive wheels individually if they spin. This enables you to pull away and accelerate on slippery surfaces, for example if the road surface is slippery on one side. In addition, more drive torque is transferred to the wheel or wheels with traction. Traction control remains active if you deactivate ESP®.

In appropriate driving situations, activate the off-road program:

- ▶ Vehicles without the ON&OFFROAD package (▷ page 252)
- ▶ Vehicles with the ON&OFFROAD package (▷ page 253)

Off-road 4ETS (Electronic Traction System)

A 4ETS system specifically suited to off-road terrain is activated automatically once the off-road program is activated on:

- Vehicles without the ON&OFFROAD package (▷ page 252)
- Vehicles with the ON&OFFROAD package (▷ page 253)

Deactivating/activating ESP®

⚠ WARNING

If you deactivate ESP®, ESP® no longer stabilises the vehicle. There is an increased risk of skidding and an accident.

Only deactivate ESP® in the situations described in the following.

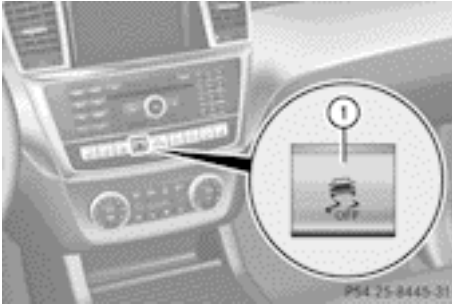

► To switch off: press button ①.

The  ESP® OFF warning lamp in the instrument cluster lights up.

► To switch on: press button ①.

The  ESP® OFF warning lamp in the instrument cluster goes out.

ESP® is activated automatically when the engine is started.

The ECO start/stop function switches the engine off automatically if the vehicle stops moving. When pulling away again, the engine starts automatically. ESP® remains in its previously selected status. Example: if ESP® was deactivated before the engine was switched off, ESP® remains deactivated when the engine is switched on again.

If ESP® is deactivated and one or more wheels start to spin, the  ESP® warning lamp in the instrument cluster flashes. In such situations, ESP® will not stabilise the vehicle.

It may be best to deactivate ESP® in the following situations:

- when using snow chains
- in deep snow
- on sand or gravel

If you deactivate ESP®:

- ESP® no longer improves driving stability.
- traction control is still activated.
- ESP® still provides support when you brake.
- engine torque is not limited and the drive wheels are able to spin. The spinning of the wheels results in a cutting action for better traction.

Off-road ESP®

An ESP® system specifically suited to off-road terrain is activated automatically once the off-road program is activated on:

- Vehicles without the ON&OFFROAD package (► page 252)
- Vehicles with the ON&OFFROAD package (► page 253)

Off-road ESP® intervenes with a delay if there is oversteering or understeering, thus improving traction.

ESP® trailer stabilisation

⚠ WARNING

If road and weather conditions are poor, trailer stabilisation will not be able to prevent the vehicle/trailer combination from swerving. Trailers with a high centre of gravity can tip over before ESP® can detect this. There is a risk of an accident.

Always adapt your driving style to the prevailing road and weather conditions.

If your vehicle/trailer combination begins to lurch, you can only stabilise the vehicle/trailer combination by depressing the brake firmly.

In this situation, ESP® assists you and can detect if the vehicle/trailer combination begins to lurch. ESP® slows the vehicle down by braking and limiting the engine output until the vehicle/trailer combination has stabilised.

Trailer stabilisation is active above speeds of about 60 km/h.

Trailer stabilisation does not work if ESP® is deactivated or disabled because of a malfunction.

Crosswind Assist

Strong crosswinds can cause your vehicle to deviate from a straight course. The crosswind driving assistance function integrated into ESP® significantly reduces these effects.

ESP® intervenes automatically according to the direction and intensity of the crosswinds affecting your vehicle.

When driving on straight roads or gentle bends, your vehicle is kept safely on course by a stabilising brake intervention.

Crosswind driving assistance is active above a vehicle speed of 80 km/h.

Crosswind driving assistance does not work if ESP® is deactivated or disabled because of a malfunction.

EBD (electronic brake force distribution)

i Observe the "Important safety notes" section (▷ page 61).

WARNING

If EBD has malfunctioned, the rear wheels can still lock, e.g. under full braking. This increases the risk of skidding and an accident.

You should therefore adapt your driving style to the different handling characteristics. Have the brake system checked at a qualified specialist workshop.

Observe information regarding indicator and warning lamps (▷ page 327) as well as display messages (▷ page 293).

EBD monitors and controls the brake pressure on the rear wheels to improve driving stability while braking.

ADAPTIVE BRAKE

ADAPTIVE BRAKE enhances braking safety and offers increased braking comfort. In addition to the braking function, ADAPTIVE BRAKE also has the HOLD function (▷ page 211) and hill start assist (▷ page 162).

PRE-SAFE® Brake

i Observe the "Important safety notes" section (▷ page 61).

PRE-SAFE® Brake is only available in vehicles with DISTRONIC PLUS.

PRE-SAFE® Brake can help you to minimise the risk of a collision with a vehicle in front or reduce the effects of such a collision. If PRE-SAFE® Brake has detected a risk of collision, you will be warned visually and acoustically as well as by automatic braking. PRE-SAFE® Brake cannot prevent a collision without your intervention.

This function will issue a warning if:

- at speeds of around 30 km/h or more over several seconds, the distance maintained to the vehicle travelling in front is insufficient.

The  distance warning lamp then lights up in the instrument cluster.

- at a speed of approximately 7 km/h or higher, you very quickly approach a vehicle in front.

An intermittent warning tone will then sound and the  distance warning lamp will light up in the instrument cluster.

► Brake immediately in order to increase the distance from the vehicle in front.

or

► Take evasive action provided it is safe to do so.

From a speed of approximately 7 km/h, if the driver and passengers have fastened their seat belts, PRE-SAFE® Brake can brake the vehicle automatically at speeds up to approximately 200 km/h.

Due to the nature of the system, particularly complicated driving conditions may cause unnecessary warnings or the unnecessary intervention of PRE-SAFE® Brake.

You can stop PRE-SAFE® Brake intervention at any time by:

- depressing the accelerator pedal further
- activating kickdown
- releasing the brake pedal.

The braking action of PRE-SAFE® Brake is ended automatically if:

- you manoeuvre to avoid the obstacle.
- there is no longer any danger of a rear-end collision.
- there is no longer an obstacle detected in front of your vehicle.

If you have activated DSR (▷ page 251) PRE-SAFE® Brake is also deactivated.

With the help of the radar sensor system, PRE-SAFE® Brake can detect obstacles that are in front of your vehicle for an extended period of time.

At speeds up to approximately 70 km/h, PRE-SAFE® Brake can also detect stationary obstacles such as stopped or parked vehicles.

If you approach an obstacle and PRE-SAFE® Brake detects a risk of a collision, the system will alert you both visually and acoustically. If you do not brake or take evasive action, the system will warn you by automatically braking the vehicle gently. If there is an increased risk of collision, preventative passenger protection measures (PRE-SAFE®) are activated

(▷ page 45). If, at speeds over 30 km/h, a risk of collision remains and you do not brake, take evasive action or significantly accelerate, automatic braking may be performed up to a level of automatic emergency braking. Automatic emergency braking is not performed until immediately prior to an accident that can no longer be avoided.

WARNING

PRE-SAFE® Brake will initially brake your vehicle by a partial application of the brakes if a danger of collision is detected. There may be a collision unless you also brake. Automatic emergency braking cannot prevent a collision. There is a risk of an accident.

Always apply the brakes yourself and try to take evasive action.

WARNING

PRE-SAFE® Brake cannot always clearly identify objects and complex traffic conditions.

In these cases, PRE-SAFE® Brake may:

- give an unnecessary warning and then brake the vehicle
- neither give a warning nor intervene

There is a risk of an accident.

Always pay particular attention to the traffic situation and be ready to brake, especially if PRE-SAFE® Brake warns you. Terminate the intervention in a non-critical driving situation.

In particular, the detection of obstacles can be impaired if there is:

- dirt on the sensors or anything else covering the sensors
- snow or heavy rain
- interference by other radar sources
- the possibility of strong radar reflections, for example, in multi-storey car parks
- a narrow vehicle travelling in front, e.g. a motorcycle
- a vehicle travelling in front on a different line

⚠ WARNING

PRE-SAFE® Brake does not react:



- to people or animals
- to oncoming vehicles
- to crossing traffic
- when cornering

As a result, PRE-SAFE® Brake may neither give warnings nor intervene in all critical situations. There is a risk of an accident.

Always pay careful attention to the traffic situation and be ready to brake.

In order to maintain the appropriate distance to the vehicle in front and thus prevent a collision, you must apply the brakes yourself.

► **To activate/deactivate:** activate or deactivate PRE-SAFE® Brake in the on-board computer (▷ page 278).

When PRE-SAFE® Brake is activated, the  symbol appears in multifunction display, as long as the HOLD function is deactivated (▷ page 211). On vehicles with the Active Parking Assist driving system, the  symbol is displayed when position **P** is engaged or you are driving faster than 35 km/h.

For PRE-SAFE® Brake to assist you when driving, the radar sensor system must be switched on (▷ page 283) and be operational.

The radar sensor system is switched off automatically in the vicinity of radio telescope facilities in the following vehicles:

- vehicles with COMAND Online and navigation
- vehicles with Audio 20 and Becker® MAP PILOT

Becker® MAP PILOT must be connected; see the separate operating instructions.

The radar sensor system must be switched off using the on-board computer in the vicinity of radio telescope facilities in the following vehicles:

- vehicles without COMAND Online and navigation
- vehicles without Audio 20 and Becker® MAP PILOT
- vehicles for Australia

For information on switching off the radar sensor system using the on-board computer, see (▷ page 283).

Following damage to the front end of the vehicle, have the configuration and operation of the radar sensors checked at a qualified specialist workshop. This also applies to collisions at slow speeds where there is no visible damage to the front of the vehicle.

STEER CONTROL

i Observe the "Important safety notes" section (▷ page 61).

STEER CONTROL helps you by transmitting a noticeable steering force to the steering wheel in the direction required for vehicle stabilisation.

This steering support is provided in particular if:

- both right wheels or both left wheels are on a wet or slippery road surface when you brake.
- the vehicle starts to skid.

If there is an ESP® malfunction, you will not receive any steering support from STEER CONTROL. Power steering will, however, continue to function.

Anti-theft systems

Immobiliser

- ▶ **To activate with the key:** remove the key from the ignition lock.
- ▶ **To activate with KEYLESS-GO:** switch the ignition off and open the driver's door.
- ▶ **To deactivate:** switch on the ignition.

The immobiliser prevents your vehicle from being started without the correct key.

When leaving the vehicle, always take the key with you and lock the vehicle. Anyone can start the engine if a valid key has been left inside the vehicle.



- ❗ The immobiliser is always deactivated when you start the engine.

ATA (Anti-Theft Alarm system)



- ▶ **To prime:** lock the vehicle with the key or KEYLESS-GO. Indicator lamp ① flashes. The alarm system is primed after approximately 15 seconds.
 - ▶ **To switch off with the key:** unlock the vehicle using the key.
- or
- ▶ Insert the key into the ignition lock.
 - ▶ **To switch off with KEYLESS-GO:** unlock the vehicle using KEYLESS-GO.
- or
- ▶ Press the Start/Stop button on the dashboard. The key must be inside the vehicle.

A visual and audible alarm is triggered if the alarm system is primed and you open:

- a door
 - the vehicle with the emergency key element
 - the tailgate
 - the bonnet
- ▶ **To turn the alarm off with the key:** press the  or  button on the key. The alarm is switched off.
- or
- ▶ Insert the key into the ignition lock. The alarm is switched off.
 - ▶ **To stop the alarm using KEYLESS-GO:** grasp the outside door handle. The key must be outside the vehicle. The alarm is switched off.

or

- ▶ Press the Start/Stop button on the dashboard. The key must be inside the vehicle. The alarm is switched off.

The alarm is not switched off, even if you close the open door that has triggered it, for example.

Tow-away protection

Function

An audible and visual alarm is triggered if your vehicle's angle of inclination is altered while tow-away protection is primed. This can occur if the vehicle is jacked up on one side, for example.

Activating

- ▶ Make sure that:

- the doors are closed.
 - the tailgate is closed.
- Only then is the tow-away protection primed.

- ▶ Lock the vehicle with the key or KEYLESS-GO.
Tow-away protection is primed after approximately 60 seconds.

Switching off

- ▶ **To switch off with key:** unlock the vehicle with the key.

or

- ▶ Insert the key into the ignition lock.
Tow-away protection is switched off automatically.

- ▶ **To switch off with KEYLESS-GO:** unlock the vehicle with KEYLESS-GO.

or

- ▶ Press the Start/Stop button on the dashboard. The key must be inside the vehicle.
Tow-away protection is switched off automatically.

Deactivating



- ▶ Remove the key from the ignition lock.
- ▶ Press button ①.
Indicator lamp ② lights up briefly.
- ▶ Lock the vehicle with the key or KEYLESS-GO.
Tow-away protection is deactivated.

Tow-away protection remains deactivated until:

- the vehicle is unlocked again and
- a door is opened and closed again and
- the vehicle is locked again.

To prevent a false alarm, deactivate the tow-away protection if you lock your vehicle and it:

- is being transported
- is being loaded onto a ferry or car transporter, for example
- is parked on a movable surface, e.g. in a split-level garage.

Interior motion sensor

Function

When the interior motion sensor is primed, a visual and audible alarm is triggered if movement is detected in the vehicle interior. This can occur if someone reaches into the vehicle interior, for example.

Activating

- ▶ Make sure that:
 - the side windows are closed.
 - the hinged side windows are closed.
 - the sliding sunroof/panorama sliding sunroof is closed.
 - there are no objects, e.g. mascots, hanging on the rear-view mirror or on the grab handles on the roof trim.

This will prevent false alarms.
- ▶ Make sure that:

- the sliding sunroof/panorama sliding sunroof is closed.
- the doors are closed.
- the tailgate is closed.

Only then is the interior motion sensor primed.

- ▶ Lock the vehicle with the key or KEYLESS-GO.
The interior motion sensor is primed after approximately 30 seconds.

Switching off

- ▶ **To switch off with the key:** unlock the vehicle using the key.

or

- ▶ Insert the key into the ignition lock.
The interior motion sensor is switched off automatically.
- ▶ **To switch off with KEYLESS-GO:** unlock the vehicle using KEYLESS-GO.

or

- ▶ Press the Start/Stop button on the dashboard. The key must be inside the vehicle.
The interior motion sensor is switched off automatically.

The interior motion sensor remains deactivated until:

- the vehicle is unlocked again and
- a door is opened and closed again and
- the vehicle is locked again.

To prevent a false alarm, deactivate the interior motion sensor if you lock your vehicle and:

- people or animals remain in the vehicle.
- the side windows remain open.
- a hinged side window remains open.
- the sliding sunroof/panorama sliding sunroof remains open.

- i UK only:** your vehicle is equipped with a double lock function. The doors cannot be opened from the inside if the vehicle has been locked with the key or with KEYLESS-GO. Deactivate the interior motion sensor before you lock the vehicle. The doors can then be opened from the inside after the vehicle has been locked from the outside. Observe the "Important safety notes" (▷ page 82).

Deactivating



- ▶ Remove the key from the ignition lock.
- ▶ Press button ①.
Indicator lamp ② flashes briefly.
- ▶ Lock the vehicle with the key or KEYLESS-GO.
The interior motion sensor is deactivated.

Useful information	76
Key	76
Doors	82
Luggage compartment	85
Side windows	89
Sliding sunroof	93

Useful information

i This Owner's Manual describes all models, series and optional equipment for your vehicle that were available at the time of going to press. National variations are possible. Note that your vehicle may not be equipped with all of the functions described. This is also the case for systems and functions relevant to safety.

i Read the information on qualified specialist workshops: (▷ page 25).

Key

Important safety notes

WARNING

Only for the United Kingdom: if the vehicle has been locked with the key or with KEYLESS-GO, the double lock function is activated as standard. It is then not possible to open the doors from inside the vehicle.

Therefore, do not leave any people behind in the vehicle, particularly children, elderly people or people requiring special assistance. As a result, they may not be able to free themselves in the event of an emergency. They could be seriously or even fatally injured by prolonged exposure to extremely high or low temperatures, for example. In this case, rescuing people from outside the vehicle is difficult.

Deactivate the interior motion sensor before you lock the vehicle. The doors can then be opened from the inside after the vehicle has been locked from the outside.

WARNING

If children are left unsupervised in the vehicle, they could:

- open a door from inside the vehicle at any time, even if it has been locked
- start the vehicle using a key which has been left in the vehicle
- release the electric parking brake

They could thereby endanger themselves and others. Never leave children unsupervised in the vehicle. Always take the key with you when leaving the vehicle, even if you are only leaving it for a short time.

WARNING

If a key ring is too heavy or too large, the weight acting on the key could cause it to turn in the ignition lock or catch on the steering wheel. This could cause the engine to be switched off suddenly. You may lose control of the vehicle and cause an accident. Do not attach any heavy or large key rings to the key that is inserted in the ignition.

- Do not keep the key:
 - electronic devices, e.g. a mobile phone or another key
 - metallic objects, e.g. coins or metal film
 - metallic objects, e.g. a metal case.



This can affect the key's functionality.

Do not keep the KEYLESS-GO key in the temperature-controlled cup holder. Otherwise, the KEYLESS-GO key will not be detected.

Keep the key away from strong magnetic fields. Otherwise, the remote control function could be affected.

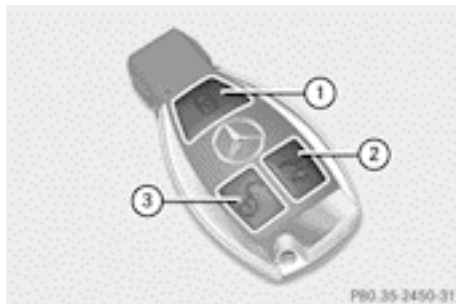
Key functions



- ①  To lock the vehicle
- ②  To open/close the tailgate
- ③  To unlock the vehicle

► **To unlock centrally:** press the  button.

If you do not open the vehicle within approximately 40 seconds of unlocking:

- the vehicle is locked again.
- the anti-theft system is primed again.

► **To lock centrally:** press the  button.

The key centrally locks/unlocks:

- the doors
- the tailgate
- the fuel filler flap

When unlocking, the turn signals flash once. When locking, they flash three times.

You can also set an audible signal to confirm that the vehicle has been locked. The audible signal can be activated and deactivated using the on-board computer (► page 283).

When it is dark, the surround lighting also comes on if it is activated in the on-board computer (► page 282).

KEYLESS-GO

General notes

Bear in mind that the engine can be started by any of the vehicle occupants if there is a KEYLESS-GO key in the vehicle.

Locking and unlocking centrally

You can start, lock or unlock the vehicle using KEYLESS-GO. To do this, you only need carry the key with you. When you touch the surface of the sensors on the vehicle's outside door handles, KEYLESS-GO establishes a radio connection between the vehicle and the key. When the engine is started and whilst you are driving, KEYLESS-GO also checks whether a valid key is in the vehicle by periodically establishing radio contact.

You can combine the KEYLESS-GO functions with the functions of a conventional key. Unlock the vehicle by using KEYLESS-GO, for instance, and lock it using the  button on the key.

When locking or unlocking with KEYLESS-GO, the distance between the key and the corresponding door handle must not be greater than 1 m.

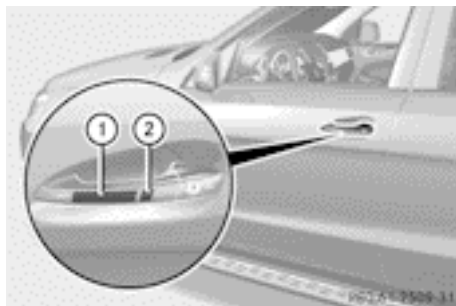

► **To unlock the vehicle:** touch the inner surface of the door handle.

► **To lock the vehicle:** touch sensor surface ①.



► **Convenience closing feature:** touch recessed sensor surface ② for an extended period.



Further information on the convenience closing feature (► page 90).

If you pull on the handle of the tailgate, only the luggage compartment of the vehicle is unlocked.

Changing the settings of the locking system



You can change the settings of the locking system. This means that only the driver's door and the fuel filler flap are unlocked when the vehicle is unlocked. This is useful if you frequently travel on your own.

► **To change the setting:** press and hold down the  and  buttons simultaneously for approximately six seconds until the battery check lamp flashes twice (▷ page 79).



❗ If the setting of the locking system is changed within the signal range of the vehicle, pressing the  or  button:

- locks or
- unlocks the vehicle

The key now functions as follows:

- **To unlock the driver's door:** press the  button once.
- **To unlock centrally:** press the  button twice.
- **To lock centrally:** press the  button.

The KEYLESS-GO function is changed as follows:

- **To unlock the driver's door:** touch the inner surface of the door handle on the driver's door.
- **To unlock centrally:** touch the inner surface of the door handle on the front-passenger door or the rear door.
- **To lock centrally:** touch the outer sensor surface on one of the door handles (▷ page 77).
- **To restore the factory settings:** press and hold down the  and  buttons simultaneously for approximately six seconds until the battery check lamp flashes twice (▷ page 79).

Emergency key element

General notes

If the vehicle can no longer be locked or unlocked with the key, use the emergency key element.

If you use the emergency key element to unlock and open the driver's door, the anti-theft alarm system will be triggered (▷ page 71).

There are several ways to turn off the alarm:

► **To turn the alarm off with the key:** press the  or  button on the key.

or

► Insert the key into the ignition lock.

or

► **To deactivate the alarm with KEYLESS-GO:** press the Start/Stop button in the ignition lock. The key must be in the vehicle.

or

► Lock or unlock the vehicle using KEYLESS-GO. The key must be outside the vehicle.

If you unlock the vehicle using the emergency key element, the fuel filler flap will not be unlocked automatically.

► **To unlock the fuel filler flap:** insert the key into the ignition lock.

Removing the emergency key element



① Release catch

② Emergency key element

- ▶ Push release catch ① in the direction of the arrow and at the same time, remove emergency key element ② from the key.

Battery of the key

Important safety notes

WARNING

Batteries are toxic and contain caustic substances. For this reason, keep batteries out of the reach of children.

If a battery has been swallowed, visit a doctor immediately.

Environmental note



Batteries contain pollutants. It is illegal to dispose of them with the household rubbish. They must be collected separately and disposed of in an environmentally responsible recycling system.







Dispose of batteries in an environmentally responsible manner. Take discharged batteries to a qualified specialist workshop or to a collection point for used batteries.

Mercedes-Benz recommends that you have the batteries replaced at a qualified specialist workshop.

Checking the battery



- ▶ Press the  or  button. The battery is working properly if battery check lamp ① lights up briefly. The battery is discharged if battery check lamp ① does not light up briefly.
- ▶ Change the battery (▶ page 79).
 - i** If the key battery is checked within the signal reception range of the vehicle, pressing the  or  button:
 - locks or
 - unlocks the vehicle
 - i** You can get a battery at any qualified specialist workshop.

Replacing the battery

You require a CR 2025 3 V cell battery.

- ▶ Take the emergency key element out of the key (▶ page 78).

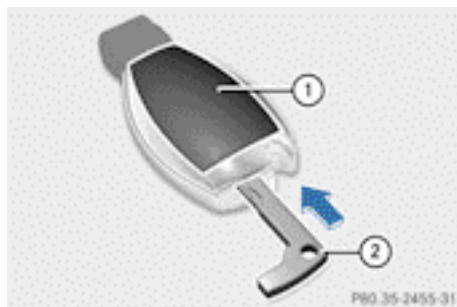







- ① Battery compartment cover
- ② Emergency key element

- ▶ Press emergency key element ② into the opening in the key in the direction of the arrow until battery compartment cover ① opens. When doing so, do not hold battery compartment cover ① shut.
- ▶ Remove battery compartment cover ①.



③ Battery

- ▶ Repeatedly tap the key against your palm until battery ③ falls out.
- ▶ Insert the new battery with the positive terminal facing upwards. Use a lint-free cloth to do so.
- ▶ Make sure that the surface of the battery is free from lint, grease and all other forms of contamination.
- ▶ Insert the front tabs of battery compartment cover ① into the housing and then press to close it.
- ▶ Insert emergency key element ② into the key.
- ▶ Check the function of all key buttons on the vehicle.

Problems with the key	
Problem	Possible causes/consequences and ► Solutions
You cannot lock or unlock the vehicle using the key.	<p>The key battery is discharged or nearly discharged.</p> <ul style="list-style-type: none"> ► Try again to lock/unlock the vehicle using the remote control function of the key. Point the tip of the key at the driver's door handle from close range and press the  or  button. <p>If this does not work:</p> <ul style="list-style-type: none"> ► Check the key battery (▷ page 79) and replace it if necessary (▷ page 79). ► Lock (▷ page 84) or unlock (▷ page 85) the vehicle using the emergency key element.
	<p>The key is faulty.</p> <ul style="list-style-type: none"> ► Lock (▷ page 84) or unlock (▷ page 85) the vehicle using the emergency key element. ► Have the key checked at a qualified specialist workshop.
You can no longer lock or unlock the vehicle using KEYLESS-GO.	<p>There is interference from a powerful source of radio waves.</p> <ul style="list-style-type: none"> ► Lock/unlock the vehicle using the remote control function of the key. Point the tip of the key at the driver's door handle from close range and press the  or  button.
	<p>There is a fault with KEYLESS-GO.</p> <ul style="list-style-type: none"> ► Lock/unlock the vehicle using the remote control function of the key. Point the tip of the key at the driver's door handle from close range and press the  or  button. ► Have KEYLESS-GO checked at a qualified specialist workshop. <p>If this does not work:</p> <ul style="list-style-type: none"> ► Check the key battery (▷ page 79) and replace it if necessary (▷ page 79). ► Lock (▷ page 84) or unlock (▷ page 85) the vehicle using the emergency key element.
You have lost a key.	<ul style="list-style-type: none"> ► Have the key deactivated at a qualified specialist workshop. ► Report the loss immediately to the vehicle insurers. ► If necessary, have the locks changed as well.
You have lost the emergency key element.	<ul style="list-style-type: none"> ► Report the loss immediately to the vehicle insurers. ► If necessary, have the locks changed as well.

Problem	Possible causes/consequences and ► Solutions
The engine cannot be started using the key.	<p>The on-board voltage is too low.</p> <ul style="list-style-type: none"> ► Switch off non-essential consumers, e.g. seat heating or interior lighting, and try to start the engine again. <p>If this does not work:</p> <ul style="list-style-type: none"> ► Check the starter battery and charge it if necessary (▷ page 384). <p>or</p> <ul style="list-style-type: none"> ► Jump-start the vehicle (▷ page 386). <p>or</p> <ul style="list-style-type: none"> ► Consult a qualified specialist workshop.
The engine cannot be started using KEYLESS-GO. The key is in the vehicle.	<p>A door is open. Therefore, the key cannot be detected as easily.</p> <ul style="list-style-type: none"> ► Close the door and try to start the vehicle again.
	<p>There is interference from a powerful source of radio waves.</p> <ul style="list-style-type: none"> ► Start your vehicle with the key in the ignition lock.

Doors

Important safety notes

WARNING

Only for the United Kingdom: if the vehicle has been locked with the key or with KEYLESS-GO, the double lock function is activated as standard. It is then not possible to open the doors from inside the vehicle.

Therefore, do not leave any people behind in the vehicle, particularly children, elderly people or people requiring special assistance. As a result, they may not be able to free themselves in the event of an emergency. They could be seriously or even fatally injured by prolonged exposure to extremely high or low temperatures, for example. In this case, rescuing people from outside the vehicle is difficult.

Deactivate the interior motion sensor before you lock the vehicle. The doors can then be opened from the inside after the vehicle has been locked from the outside.

WARNING

If children are left unsupervised in the vehicle, they could:

- open a door from inside the vehicle at any time, even if it has been locked
- start the vehicle using a key which has been left in the vehicle
- release the electric parking brake

They could thereby endanger themselves and others. Never leave children unsupervised in the vehicle. Always take the key with you when leaving the vehicle, even if you are only leaving it for a short time.

Unlocking and opening the doors from the inside

For all countries except the United Kingdom: you can open a door from inside the vehicle even if it has been locked.

If the vehicle has been locked with the key or with KEYLESS-GO, opening a door from the inside will trigger the anti-theft alarm system. Switch off the alarm (▷ page 71).

United Kingdom only: if the vehicle has been locked with the key or with KEYLESS-GO, the double lock function is activated as standard. It is then not possible to open the doors from inside the vehicle. Deactivate the interior motion sensor (▷ page 72) before you lock the vehicle. The doors can then be opened from the inside after the vehicle has been locked from the outside. The anti-theft alarm system is triggered if the door is opened from the inside. Switch off the alarm (▷ page 71).

You can only open the rear doors from inside the vehicle if they are not secured by the child-proof locks (▷ page 60).



► Pull door handle ②.

If the door is locked, locking knob ① pops up. The door is unlocked and can be opened.

Centrally locking and unlocking the vehicle from the inside

You can centrally lock or unlock the vehicle from the inside. The buttons are located on both front doors.

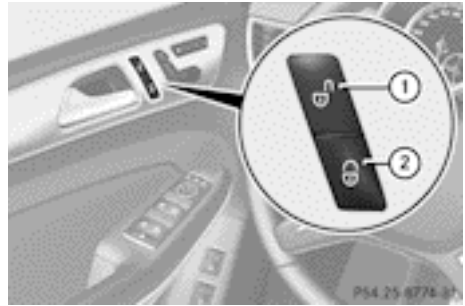

① To unlock

② To lock

► **To unlock:** press button ①.

► **To lock:** press button ②.

If the front-passenger door is closed, the vehicle locks.

Meanwhile, the fuel filler flap will not be locked or unlocked.

You cannot unlock the vehicle centrally from the inside if the vehicle has been locked with the key or KEYLESS-GO.

For all countries except the United Kingdom: you can open a door from inside the vehicle even if it has been locked.

United Kingdom only: if the vehicle has been locked with the key or with KEYLESS-GO, the double lock function is activated as standard. It is then not possible to open the doors from inside the vehicle. Deactivate the interior motion sensor (▷ page 72) before you lock the vehicle. The doors can then be opened from the inside after the vehicle has been locked from the outside.

If the vehicle has been locked using the locking button for the central locking, or has been locked automatically, and a door is opened from the inside:

- the vehicle will be fully unlocked if it had previously been fully unlocked.
- only the door which has been opened from the inside is unlocked if only the driver's door had been previously unlocked.

Automatic locking feature

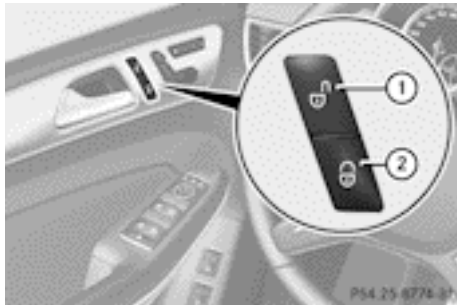

① To deactivate

② To activate

- ▶ **To deactivate:** press and hold button ① for about five seconds until a tone sounds.
- ▶ **To activate:** press and hold button ② for about five seconds until a tone sounds.

i If you press one of the two buttons and do not hear a tone, the relevant setting has already been selected.

The vehicle is locked automatically when the ignition is switched on and the wheels are turning.

You could therefore be locked out if:

- the vehicle is being pushed.
- the vehicle is being towed.
- the vehicle is being tested on a dynamometer.

You can also switch the automatic locking function on and off using the on-board computer (▷ page 283).

Power closing feature

⚠ WARNING

Make sure that nobody can become trapped as you close the doors and tailgate.

If there is a danger of being trapped, pull the door handle on the inside or outside or pull the tailgate handle.

Do not activate the power closing feature by tampering with the lock mechanism. You could otherwise injure yourself.

⚠ WARNING

Make sure that the doors and tailgate are always fully closed. Otherwise, a door or the tailgate could open during the journey and endanger you or others.

The power closing feature pulls the doors and tailgate into their locks automatically even if they are only partly closed.

- ▶ **Power closing feature (doors):** push the door up to the first detent position in the lock.
The power closing feature will pull the door fully closed.
- ▶ **Power closing tailgate:** gently push the tailgate closed.
The power closing feature will pull the tailgate fully closed.

Unlocking the driver's door (emergency key element)

If the vehicle can no longer be unlocked with the key, use the emergency key element.

If you use the emergency key element to unlock and open the driver's door, the anti-theft alarm system will be triggered (▷ page 71).

- ▶ Take the emergency key element out of the key (▷ page 78).
- ▶ Insert the emergency key element into the lock of the driver's door as far as it will go.

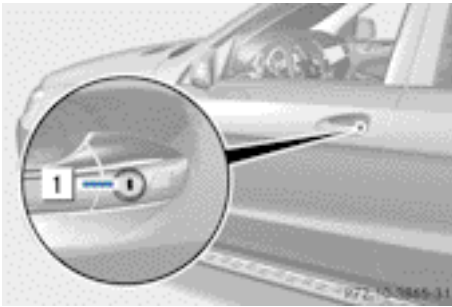

1 To unlock

- ▶ Turn the emergency key element anti-clockwise to position **1**.
The door is unlocked.
- i** On right-hand-drive vehicles, turn the emergency key element clockwise.
- ▶ Turn the emergency key element back and remove it.
- ▶ Insert the emergency key element into the key.

Locking the vehicle (emergency key element)

If the vehicle can no longer be locked with the key, use the emergency key element.

- ▶ Open the driver's door.
- ▶ Close the front-passenger door, the rear doors and the tailgate.
- ▶ Press the locking button (▷ page 83).
- ▶ Check whether the locking knobs on the front-passenger door and the rear doors are still visible. Press down the locking knobs manually, if necessary (▷ page 82).
- ▶ Close the driver's door.
- ▶ Take the emergency key element out of the key (▷ page 78).
- ▶ Insert the emergency key element into the lock of the driver's door as far as it will go.

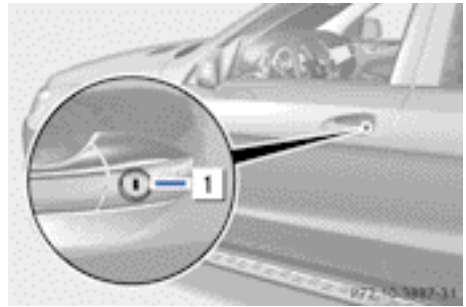

1 To lock

- ▶ Turn the emergency key element clockwise as far as it will go to position **1**.
- i** On right-hand-drive vehicles, turn the emergency key element anti-clockwise.
- ▶ Turn the emergency key element back and remove it.
- ▶ Make sure that the doors and the tailgate are locked.
- ▶ Insert the emergency key element into the key.
- i** If you lock the vehicle as described above, the fuel filler flap is not locked. The anti-theft alarm system is not primed.

Luggage compartment

Important safety notes

⚠ WARNING

If the engine is running and the tailgate is open, exhaust gases can enter the vehicle interior. This could result in poisoning. Therefore, make sure that the tailgate is always closed when the engine is running.

! The tailgate swings upwards and to the rear when opened. Therefore, make sure that there is sufficient clearance above and behind the tailgate.

i Opening dimensions of the tailgate (▷ page 431).

Do not leave the key in the luggage compartment. You could otherwise lock yourself out.

You can:

- close the tailgate manually from outside
- open and close the tailgate automatically from outside
- open and close the tailgate automatically from inside
- limit the opening angle of the tailgate
- unlock the tailgate from inside with the emergency release

Opening/closing from the outside

Opening

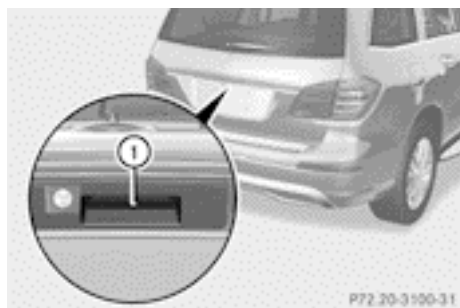

- ▶ Press the  button on the key.
- ▶ Pull handle ① and release it.
The tailgate opens automatically.

Closing

WARNING

Make sure that nobody can become trapped as you close the tailgate.



- ▶ Pull the tailgate down using recess ①.
- ▶ Allow the tailgate to drop into the lock.
- ▶ Lock the vehicle if necessary with the  button on the key or with KEYLESS-GO.

i If a KEYLESS-GO key is detected in the luggage compartment, the tailgate will not lock.

Opening/closing automatically from the outside

Important safety notes

WARNING

Only for the United Kingdom: if the vehicle has been locked with the key or with KEYLESS-GO, the double lock function is activated as standard. It is then not possible to open the doors from inside the vehicle.

Therefore, do not leave any people behind in the vehicle, particularly children, elderly people or people requiring special assistance. As a result, they may not be able to free themselves in the event of an emergency. They could be seriously or even fatally injured by prolonged exposure to extremely high or low temperatures, for example. In this case, rescuing people from outside the vehicle is difficult.

Deactivate the interior motion sensor before you lock the vehicle. The doors can then be opened from the inside after the vehicle has been locked from the outside.

WARNING

Monitor the tailgate opening and closing procedures to make sure that nobody can become trapped. To stop the opening or closing procedure, press the closing button on the tailgate again or pull the handle on the outside of the tailgate.

! The tailgate swings upwards and to the rear when opened. Therefore, make sure

that there is sufficient clearance above and behind the tailgate.

- i** Tailgate opening dimensions
(▷ page 431).

Opening the tailgate automatically

You can open the tailgate automatically with the key or the handle in the tailgate.

- ▶ Press and hold the  button on the key until the tailgate opens.

or

- ▶ When the tailgate is unlocked, pull the handle and let it go again immediately.

Closing the tailgate automatically

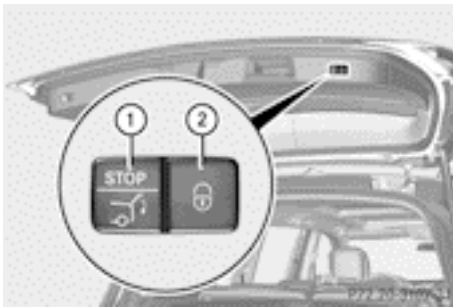

Closing and locking button (example: vehicle with KEYLESS-GO)

- ① Closing button
- ② Locking button

- ▶ **To close:** press closing button ① on the tailgate.

or

- ▶ Press and hold the  button on the key until the tailgate closes.

Vehicles with KEYLESS-GO: you can simultaneously close and lock the tailgate.

- ▶ Press locking button ② on the tailgate.
If a KEYLESS-GO key is detected outside the vehicle, the tailgate closes and locks.

All the doors must be shut and the key located in the vicinity of the tailgate.

- i** The tailgate cannot be opened and closed with the key if there is a key in the ignition. If the tailgate touches an object while closing, the closing procedure is interrupted and the tailgate reopens.
- i** If a KEYLESS-GO key is detected in the luggage compartment, the tailgate will not lock.

Opening/closing automatically from the inside

Important safety notes

WARNING

Monitor the tailgate opening and closing procedures to make sure that nobody can become trapped. To halt the opening or closing procedure, press or pull the tailgate's remote operating button from the driver's seat again.

- !** The tailgate swings upwards and to the rear when opened. Therefore, make sure that there is sufficient clearance above and behind the tailgate.

- i** Tailgate opening dimensions
(▷ page 431).

Opening and closing



You can open and close the tailgate from the driver's seat when the vehicle is stationary and unlocked.

- ▶ **To open:** pull remote operating switch ① for the tailgate until the tailgate opens.
- ▶ **To close:** turn the key to position 1 or 2 in the ignition lock.
- ▶ Press remote operating switch for tailgate ① until the tailgate is closed.
- ❗ If the tailgate touches an object while closing, the closing procedure is interrupted and the tailgate reopens.

Limiting the opening angle of the tailgate

Important safety notes

- ❗ Make sure there is sufficient clearance to open the tailgate fully when setting the opening angle. The tailgate could otherwise be damaged. Ideally, set the opening angle outside.

Activating

You can limit the opening angle of the tailgate. This is possible in the top half of its opening range, up to approximately 10 cm before the stop.

This could be useful, for example, if there is insufficient space above the tailgate.

- ▶ **To open the tailgate:** pull the handle on the tailgate.
- ▶ **To stop the opening procedure at the desired position:** press the closing button (▷ page 86) in the tailgate or pull the handle on the outside of the tailgate again.
- ▶ **To store the position:** press and hold the closing button in the tailgate until you hear a short tone.
The opening angle limiter is activated. The tailgate then stops in the stored position when opened.

Switching off

- ▶ Press and hold the closing button (▷ page 86) in the tailgate until you hear two short tones.

Tailgate emergency release

Important safety notes

- ❗ The tailgate swings upwards and to the rear when opened. Therefore, make sure that there is sufficient clearance above and behind the tailgate.

- ❗ Opening dimensions of the tailgate (▷ page 431).

If the tailgate can no longer be opened from outside the vehicle, use the emergency release on the inside of the tailgate.

Opening

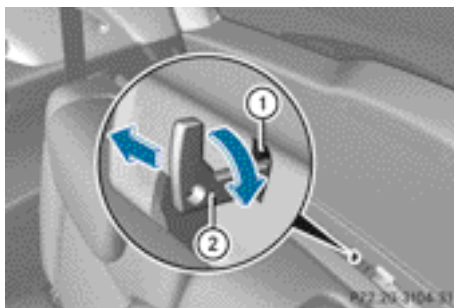

- ▶ Take the emergency key element out of the key (▷ page 78).
- ▶ Insert emergency key element ② into the opening in trim ①.
- ▶ Turn emergency key element ② 90° clockwise.
- ▶ Push emergency key element ② in the direction of the arrow and open the tailgate.

Side windows

Important safety notes

WARNING

Make sure that nobody can become trapped between the side window and the door frame when a side window is opened. Do not touch or lean against the side window during the opening procedure. You could become trapped between the side window and the door frame as the side window moves down. If there is a risk of becoming trapped, release the switch or pull the switch upwards to close the side window again.

WARNING

Make sure that nobody can become trapped as you close a side window. If there is a risk of becoming trapped, release the switch or press it again to open the side window again.

WARNING

Children may injure themselves if they open or close the side windows.

Never leave children unsupervised in the vehicle. Always take the key with you when leaving the vehicle, even if you are only leaving it for a short time.

WARNING

Do not leave children unsupervised in the vehicle, even if they are secured in a child restraint system. The children could:

- be seriously or even fatally injured on parts of the vehicle
- be seriously or even fatally injured by prolonged exposure to extremely high or extremely low temperatures

If children open a door, they could:

- seriously or even fatally injure other people
- get out of the vehicle and injure themselves, or be seriously or even fatally injured by a passing vehicle

Activate the child-proof locks/override feature if children are travelling in the vehicle.

They could otherwise open doors or side windows while the vehicle is in motion and thereby injure themselves or others.

Opening and closing the side windows

The switches for all side windows are located on the driver's door. There is also a switch on each door for the corresponding side window. The switches on the driver's door take precedence.

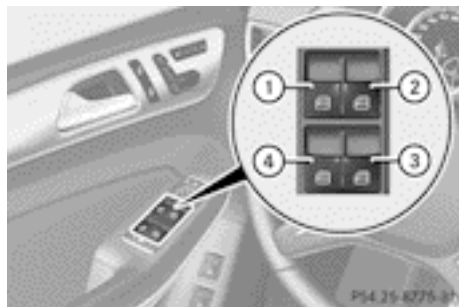

- ① Front left
- ② Front right
- ③ Rear right
- ④ Rear left

► Turn the key to position **1** or **2** in the ignition lock.

► **To open:** press the corresponding switch.

► **To close:** pull the corresponding switch.

i If you press the switch beyond the point of resistance, an automatic opening/closing process is started in the corresponding direction. You can stop automatic operation by pressing again.

i You can continue to operate the side windows after switching off the engine or removing the key. This function remains active for five minutes or until the driver's or front-passenger door is opened.

i The side windows cannot be operated from the rear when the override feature for the side windows is activated (▷ page 60).

Opening and closing the hinged side windows

Important safety notes





WARNING

Make sure that nobody can become trapped as you close the hinged side windows. If there is a risk of becoming trapped, release the switch or push the switch again to reopen the side window.

Opening and closing

The hinged side windows are operated electrically from the driver's seat.



- ▶ Make sure that the key is in position **1** or **2** in the ignition lock.
 - ▶ **To open fully:** press switch  and release.
 - ▶ **To close fully:** pull switch  and release.
 - ▶ **To stop the closing procedure:** press switch  again.
Both hinged side windows open fully.
-  If the hinged side windows are blocked when closing, the closing procedure is interrupted and the hinged side windows open again fully.

Convenience opening feature



General notes

You can ventilate the vehicle before you start driving. To do this, the key is used to carry out the following functions simultaneously:

- unlock the vehicle
- open the side windows
- open the hinged side windows
- open the sliding sunroof or the panorama sliding sunroof and the roller sunblinds
- switch on the seat ventilation for the driver's seat

 The convenience opening feature can only be operated using the key. The key must be close to the driver's door handle.

Convenience opening feature

- ▶ Point the tip of the key at the driver's door handle.
- ▶ Press and hold the  button until the side windows and the sliding sunroof or the panorama sliding sunroof are in the desired position.
If the roller sunblinds of the panorama sliding sunroof are closed, the roller sunblinds are opened first.
- ▶ Press and hold the  button again until the panorama sliding sunroof is in the desired position.
- ▶ **To interrupt convenience opening:** release the  button.



Convenience closing feature

Important safety notes

WARNING

When using the convenience closing feature, make sure that nobody can become trapped. Proceed as follows if there is a risk of entrapment:

With the key:

- release the  button.
- press and hold the  button until the side windows and the sliding sunroof or the panorama sliding sunroof open again.

With KEYLESS-GO:

- release the sensor surface on the door handle.
- pull the door handle immediately and hold it.

The side windows and the sliding sunroof or the panorama sliding sunroof open.

When you lock the vehicle, you can simultaneously:

- close the side windows
- close the hinged side windows
- close the sliding sunroof or the panorama sliding sunroof



On vehicles with a panorama sliding sunroof, you can then close the roller sunblinds.

Using the key

The key must be close to the driver's door handle.

- ▶ Point the tip of the key at the driver's door handle.
- ▶ Press and hold the  button until the side windows and the sliding sunroof or the panorama sliding sunroof are fully closed.
- ▶ Make sure that all the side windows and the sliding sunroof or panorama sliding sunroof are closed.

On vehicles with a panorama sliding sunroof:

- ▶ Press and hold the  button again until the roller sunblinds of the panorama sliding sunroof close.
- ▶ **To interrupt convenience closing:** release the  button.

Using KEYLESS-GO

The KEYLESS-GO key must be outside the vehicle. All the doors must be closed.

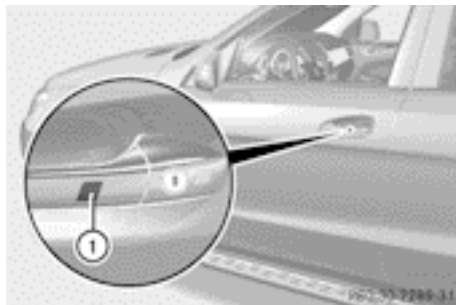

- ▶ Touch recessed sensor surface ① on the door handle until the side windows and the sliding sunroof or the panorama sliding sunroof are fully closed.
- ▶ **i** Make sure you only touch recessed sensor surface ①.
- ▶ Make sure that all the side windows and the sliding sunroof or panorama sliding sunroof are closed.

On vehicles with a panorama sliding sunroof:

- ▶ Touch recessed sensor surface ① on the door handle again until the roller sunblinds of the panorama sliding sunroof close.
- ▶ **To interrupt convenience closing:** release recessed sensor surface ① on the door handle.

Resetting the side windows

If a side window can no longer be closed fully, you must reset it.

- ▶ Close all doors.
- ▶ Turn the key to position **1** or **2** in the ignition lock.
- ▶ Pull the corresponding switch on the door control panel until the side window is completely closed. (▷ page 89)
- ▶ Hold the switch for an additional second.

If the side window opens again slightly:

- ▶ Immediately pull the corresponding switch on the door control panel until the side window is completely closed (▷ page 89).
- ▶ Hold the switch for an additional second.
- ▶ If the corresponding side window remains closed after the button has been released, the side window has been reset correctly. If this is not the case, repeat the steps above again.

Problems with the side windows

WARNING

Closing the side windows with increased force or without the anti-entrapment feature could lead to serious or even fatal injury. Make sure that nobody can become trapped when closing the side windows.

Problem	Possible causes/consequences and ► Solutions
A side window cannot be closed because it is blocked by objects, e.g. leaves in the window guide.	<ul style="list-style-type: none"> ► Remove the objects. ► Close the side window.
A side window cannot be closed and you cannot see the cause.	<p>If a side window is obstructed during closing and reopens again slightly:</p> <ul style="list-style-type: none"> ► Immediately after the window blocks, pull the corresponding switch again until the side window has closed. The side window is closed with increased force. <p>If a side window is obstructed again during closing and reopens again slightly:</p> <ul style="list-style-type: none"> ► Immediately after the window blocks, pull the corresponding switch again until the side window has closed. The side window is closed without the anti-entrapment feature.

Sliding sunroof

Important safety notes

WARNING

Make sure that nobody can become trapped when opening and closing the sliding sunroof.

If there is a risk of entrapment, release the switch immediately. During automatic operation, push the switch briefly in any direction to stop the sliding sunroof.

WARNING

The glass in the panorama sunroof could break in an accident. If you are not wearing a seat belt, there is a risk that you could be thrown through the opening in the event of the vehicle overturning. Therefore, always wear a seat belt to reduce the risk of injuries.

WARNING

Children could injure themselves if they operate the sliding sunroof.

Never leave children unsupervised in the vehicle. Always take the key with you when leaving the vehicle, even if you are only leaving it for a short time.

! Only open the panorama sliding sunroof if it is free of snow and ice. Otherwise, malfunctions may occur.

Do not allow anything to protrude from the sliding sunroof. Otherwise, the seals could be damaged.

i Resonance noises can occur in addition to the usual airflow noises when the sliding sunroof is open. They are caused by minor pressure fluctuations in the vehicle interior.

Change the position of the sliding sunroof or open a side window. The noise will be reduced or eliminated.

Your vehicle may be fitted with a sliding sunroof or a panorama sliding sunroof. In this section, the term "sliding sunroof" refers to both types of sliding sunroof.

Operating the sliding sunroof

Opening and closing

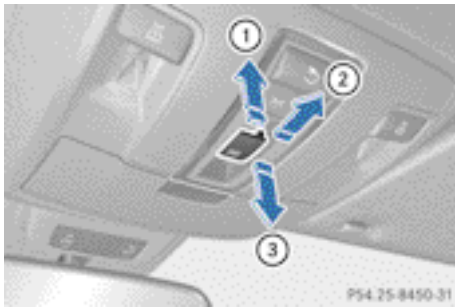

Overhead control panel

① To raise

② To open

③ To close/lower

▶ Turn the key to position **1** or **2** in the ignition lock.

▶ Press or pull the switch in the corresponding direction.

i If you press the switch beyond the point of resistance, an automatic opening/closing process is started in the corresponding direction. You can stop automatic operation by pressing again.

The sun protection cover automatically opens along with the sliding sunroof. You can open or close the sun protection cover manually when the sliding sunroof is raised or closed.

i You can continue to operate the sliding sunroof after switching off the engine or removing the key. This function remains active for five minutes or until the driver's or front-passenger door is opened.

Rain-closing feature

If the key is in position **0** in the ignition lock or if it is removed, the sliding sunroof closes automatically:

- if it starts to rain
- at extreme outside temperatures
- after six hours
- if there is a malfunction in the power supply

The rear of the sliding sunroof is then raised in order to ventilate the vehicle interior.

i If the sliding sunroof is obstructed while being closed by the rain-closing feature, it opens again slightly. The rain-closing feature is then deactivated.

The sliding sunroof does not close if:

- it is raised at the rear.
- it is blocked.
- no rain is falling on the area of the wind-screen being monitored by the rain sensor (e.g. because the vehicle is under a bridge or in a carport).

Resetting

! If the sliding sunroof still cannot be opened or closed fully after resetting, contact a qualified specialist workshop.

Reset the sliding sunroof if it does not move smoothly.

▶ Turn the key to position **1** or **2** in the ignition lock.

▶ Raise the sliding sunroof fully at the rear (▷ page 94).

▶ Keep the switch pressed for another second.

▶ Make sure that the sliding sunroof can be fully opened and closed again (▷ page 94).

▶ If this is not the case, repeat the steps above again.

Operating the panorama sliding sunroof

Opening and closing

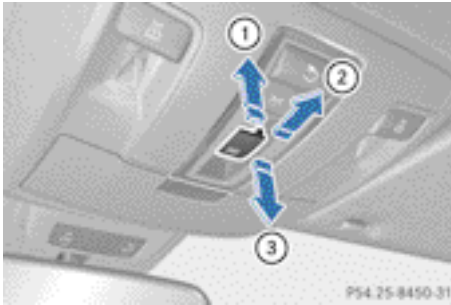

Overhead control panel

- ① To raise
- ② To open
- ③ To close/lower

The panorama sliding sunroof can only be operated when the roller sunblind is open (▷ page 96).

- ▶ Turn the key to position **1** or **2** in the ignition lock.
- ▶ Press or pull the switch in the corresponding direction.
- ❗ If you press the switch beyond the point of resistance, an automatic opening/closing process is started in the corresponding direction. You can stop automatic operation by pressing again.

The automatic opening feature is available only when the sliding sunroof is closed.

Rain-closing feature

If the key is in position **0** in the ignition lock or if it is removed, the panorama sliding sunroof closes automatically:

- if it starts to rain
- at extreme outside temperatures
- after six hours
- if there is a malfunction in the power supply

The panorama sliding sunroof remains raised at the rear in order to allow ventilation of the vehicle interior.

- ❗ If the panorama sliding sunroof is obstructed while being closed by the rain-closing feature, it opens again slightly. The rain-closing feature is then deactivated.

The panorama sliding sunroof does not close if:

- it is raised at the rear.
- it is blocked.
- no rain is falling on the area of the wind-screen being monitored by the rain sensor (e.g. because the vehicle is under a bridge or in a carport).

Operating the panorama sliding sunroof roller sunblinds

Important safety notes

WARNING

Make sure that nobody can become trapped as you open or close the roller sunblinds.

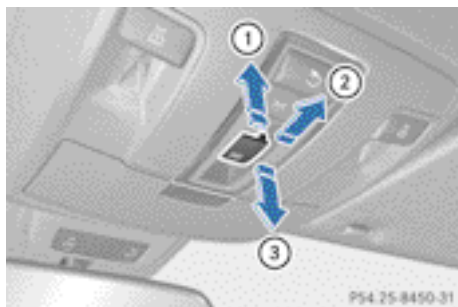

The roller sunblinds shield the vehicle interior from sunlight. The two roller sunblinds can only be opened and closed together when the panorama sliding sunroof is closed.

Opening and closing the roller sunblinds



Overhead control panel

- ① To open
- ② To open
- ③ To close



- ▶ Turn the key to position **1** or **2** in the ignition lock.
- ▶ Press or pull the  switch in the corresponding direction.
- i** If you press the  switch beyond the point of resistance, an automatic opening/closing process is started in the corresponding direction. You can stop automatic operation by pressing again.

Resetting the panorama sliding sunroof and the roller sunblinds

- !** If the panorama sliding sunroof and the roller sunblind cannot be fully opened or closed after resetting, contact a qualified specialist workshop.

Reset the panorama sliding sunroof and the roller sunblinds if the panorama sliding sunroof or the roller sunblinds do not move smoothly.

- ▶ Turn the key to position **1** or **2** in the ignition lock.
- ▶ Pull the  switch repeatedly to the point of resistance in the direction of arrow **③** until the panorama sliding sunroof is fully closed.



- ▶ Keep the  switch pulled for an additional second.
- ▶ Pull the  switch repeatedly to the point of resistance in the direction of arrow **③** until the roller sunblinds are fully closed.
- ▶ Keep the  switch pulled for an additional second.
- ▶ Make sure that the panorama sliding sunroof (▷ page 95) and the roller sunblinds (▷ page 96) can be fully opened again.
- ▶ If this is not the case, repeat the steps above again.

Problems with the sliding sunroof

WARNING

You could be severely or even fatally injured when closing the sliding sunroof with increased closing force or if the anti-entrapment feature is deactivated. Make sure that nobody can become trapped when closing the sliding sunroof.

Your vehicle may be fitted with a sliding sunroof or a panorama sliding sunroof. In this section, the term "sliding sunroof" refers to both types of sliding sunroof.

Problem	Possible causes/consequences and ► Solutions
<p>The sliding sunroof cannot be closed and you cannot see the cause.</p>	<p>If the sliding sunroof is obstructed during closing and reopens again slightly:</p> <ul style="list-style-type: none"> ► Immediately after the sliding sunroof blocks, pull the  switch in the overhead control panel down to the point of resistance and hold it until the sliding sunroof is closed. The sliding sunroof is closed with increased force. <p>If the sliding sunroof is obstructed again during closing and reopens again slightly:</p> <ul style="list-style-type: none"> ► Immediately after the sliding sunroof blocks, pull the  switch in the overhead control panel down to the point of resistance and hold it until the sliding sunroof is closed. The sliding sunroof is closed without the anti-entrapment feature.

Useful information	100
Correct driver's seat position	100
Seats	101
Steering wheel	110
Mirrors	112
Memory function	115

Useful information

i This Owner's Manual describes all models, series and optional equipment for your vehicle that were available at the time of going to press. National variations are possible. Note that your vehicle may not be equipped with all of the functions described. This is also the case for systems and functions relevant to safety.

i Read the information on qualified specialist workshops: (▷ page 25).

Correct driver's seat position



- ▶ Observe the safety guidelines on seat adjustment (▷ page 101).
- ▶ Make sure that seat ③ is adjusted properly.

Electrical seat adjustment (▷ page 102)

When adjusting the seat, make sure that:

- you are as far away from the driver's airbag as possible.
- you are sitting in a normal upright position.
- you can fasten the seat belt properly.
- you have moved the backrest to an almost vertical position.

- you have set the seat angle so that your thighs are gently supported.
- you can depress the pedals properly.
- ▶ Check whether the head restraint is adjusted properly.

When doing so, make sure that you have adjusted the head restraint so that the back of your head is supported at eye level by the centre of the head restraint.

- ▶ Observe the safety guidelines on steering wheel adjustment (▷ page 110).
- ▶ Make sure that steering wheel ① is adjusted properly.

Adjusting the steering wheel manually (▷ page 110)

Adjusting the steering wheel electrically (▷ page 110)

When adjusting the steering wheel, make sure that:

- you can hold the steering wheel with your arms slightly bent.
- you can move your legs freely.
- you can see all the displays in the instrument cluster clearly.
- ▶ Observe the safety guidelines for seat belts (▷ page 46).
- ▶ Check whether you have fastened seat belt ② properly (▷ page 47).

The seat belt should:

- fit snugly across your body
- be routed across the middle of your shoulder
- be routed in your pelvic area across the hip joints
- ▶ Before starting off, adjust the rear-view mirror and the exterior mirrors in such a way that you have a good view of road and traffic conditions (▷ page 112).
- ▶ **Vehicles with a memory function:** save the seat, steering wheel and exterior mirror settings with the memory function (▷ page 115).

Seats

Important safety notes

WARNING

The seats can still be adjusted when there is no key in the ignition lock. For this reason, children should never be left unsupervised in the vehicle. They could adjust the seats and become trapped.

WARNING

Only adjust the driver's seat when the vehicle is stationary. You will otherwise be distracted from the road and traffic conditions and you could lose control of the vehicle as a result of the seat moving. This could cause an accident.

WARNING

If you adjust the seat height carelessly, you or others could be trapped and thereby injured. Children in particular could unintentionally press the buttons to electrically adjust the seats and become trapped.

Take care that:

- while moving the seats, your hands do not get under the lever assembly of the seat adjustment system.
- children in the vehicle do not slide their hands under the levers.

WARNING

Make sure that nobody can become trapped when adjusting the seats.

Observe the notes on airbags.

Secure children as recommended; see the "Children in the vehicle" section.

WARNING

Make sure that the back of your head is supported at eye level by the central area of the head restraint. If your head is not supported correctly by the head restraint, you could suffer a severe neck injury in the event of an

accident. Never drive if the head restraints are not engaged and set correctly.

WARNING

A seat belt can only offer its intended degree of protection when the backrest is almost vertical and the occupant is sitting upright. Avoid seat positions that do not allow the seat belt to be routed correctly. Adjust the backrest so that it is as upright as possible. Never travel with the backrest reclined too far backwards. You could otherwise be seriously or even fatally injured in the event of an accident or sudden braking.

 To avoid damage to the seats and the seat heating, observe the following information:

- do not spill any liquids on the seats. If liquid is spilled on the seats, dry them as soon as possible.
- if the seat covers are damp or wet, do not switch on the seat heating. The seat heating should also not be used to dry the seats.
- clean the seat covers as recommended; see "Interior care".
- do not transport heavy loads on the seats. Do not place sharp objects on the seat cushions, e.g. knives, nails or tools. The seats should only be occupied by passengers, if possible.
- when the seat heating is in operation, do not cover the seats with insulating materials, e.g. blankets, coats, bags, seat covers, child seats or booster seats.

 Make sure that there are no objects in the footwell or behind the seats when moving the seat back. There is a risk that the seats and/or the objects could be damaged.

 The head restraints cannot be removed from the front seats. The rear-compartment head restraints, however, can be removed (▷ page 104).

For more information, contact a qualified specialist workshop.

- i** Further related subjects:
 - Luggage compartment enlargement (folding down the rear bench seat) (▷ page 341)

Adjusting the seats electrically

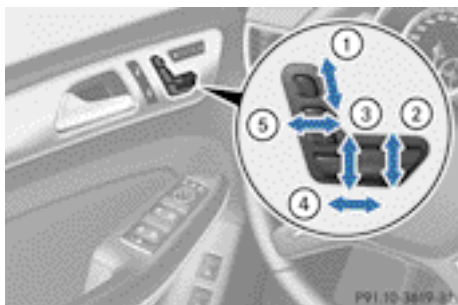

- ① Head restraint height
- ② Seat cushion angle
- ③ Seat height
- ④ Seat fore-and-aft adjustment
- ⑤ Backrest angle

- i** Vehicles with memory function: if PRE-SAFE® has been triggered, the front-passenger seat will be moved to a better position if it was previously in an unfavourable position.
- i** You can store the seat settings using the memory function (▷ page 115).
- i** Vehicles with memory function: when the seat is moved forwards or backwards, the headrest is moved up or down automatically.

Adjusting the head restraints

Adjusting the head restraints manually

Adjusting the head restraint height

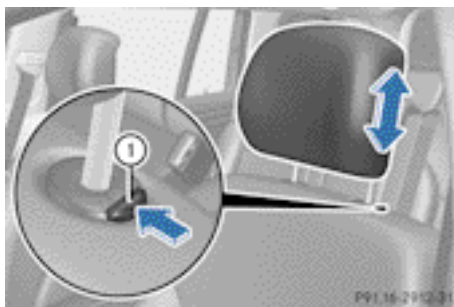

- ▶ **To raise:** pull the head restraint up to the desired position.
- ▶ **To lower:** press release catch ① in the direction of the arrow and push the head restraint down to the desired position.

Adjusting the head restraint fore-and-aft position

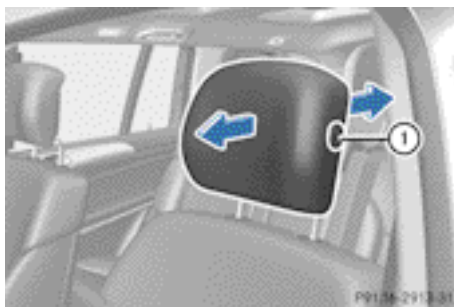

This function allows you to adjust the distance between the head restraint and the back of the head.

- ▶ **To move forwards:** pull the head restraint forwards in the direction of the arrow until it engages.

There are a number of detents.

- ▶ **To move backwards:** press and hold release button ① and push the head restraint backwards.
- ▶ When the head restraint is in the desired position, release the button and make sure that the head restraint is engaged in position.

Adjusting the head restraints electrically

- ▶ **To adjust the head restraint height:** slide the switch for head restraint adjustment (▷ page 102) up or down in the direction of the arrow.

Adjusting the luxury head restraints

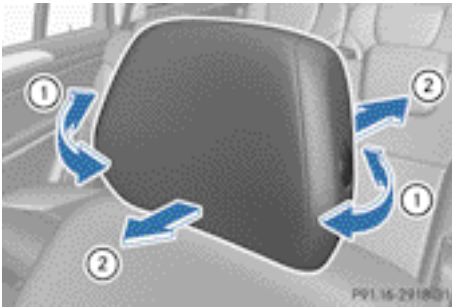

The 1st row of seats has luxury head restraints.

- ▶ **To adjust the side bolsters of the head restraint:** push or pull right and/or left-hand side bolster ① into the desired position.
- ▶ **To adjust the fore-and-aft position of the head restraint:** push or pull the head restraint in the direction of arrow ②.

Rear seat head restraints

Adjusting the rear seat head restraint height

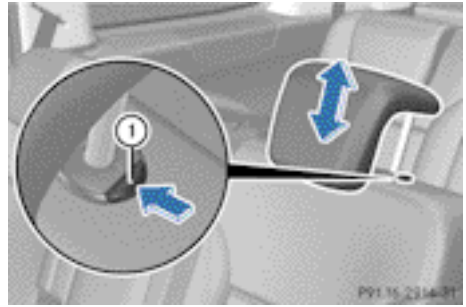

- ▶ Once the head restraint is fully lowered, press release catch ①.
- ▶ **To raise:** pull the head restraint up to the desired position.
- ▶ **To lower:** press release catch ① and push the head restraint down until it is in the desired position.

Adjusting the rear seat head restraint angle

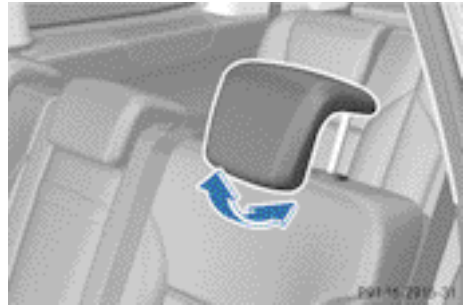

Adjust the head restraints so that they are as close as possible to your head.

You can only adjust the two outer head restraints.

- ▶ Using both hands, reach back and grasp the sides of the head restraint.
- ▶ Pull the lower edge of the head restraint forwards or back until it is in the desired position.

Removing and fitting the rear seat head restraints

WARNING

Occupants should only travel sitting on seats that have the head restraints fitted. This reduces the risk of injury to the occupant in the event of an accident.

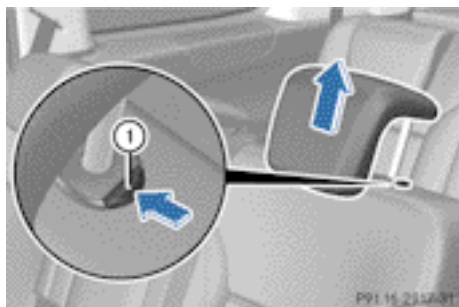

- ▶ **To remove:** pull the head restraint up as far as it will go.
- ▶ Press release catch ① and pull the head restraint out of the guides.
- ▶ **To refit:** insert the head restraint so that the notches on the bar are on the left when viewed in the direction of travel.
- ▶ Push the head restraint down until you hear it engage in position.

Rear seats (2nd and 3rd row of seats)

Important safety notes

WARNING

If the seat and backrest are not engaged, they can fold forwards, e.g. in the event of sudden braking or an accident.

- This will cause the vehicle occupants to be forced into the seat belt by a seat or backrest which is not engaged. The seat belt can

no longer offer the intended level of protection and can even cause injuries.

- A child restraint system would no longer be anchored or positioned correctly and would not be able to perform its required function.
- Objects or loads in the load compartment may not be restrained by the backrests.

This poses an increased risk of injury.

Always make sure that the seat and backrest are engaged as described:

- before travelling with a passenger on a seat with the EASY-ENTRY/EXIT feature
- after you have adjusted the seat
- after the EASY-ENTRY/EXIT feature has been used
- after the load compartment enlargement has been folded forwards

Adjusting the backrest angle (2nd row of seats)

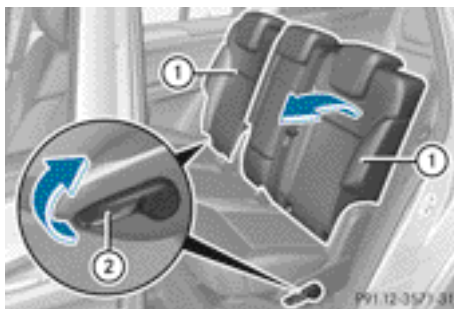

You can adjust the angle of the backrests in the second row of seats. There are ten detent positions.

- ▶ Pull the left or right release lever ② upwards in the direction of the arrow until the relevant backrest ① is fully released.
- ▶ Pull the backrest ① forwards in the direction of the arrow and allow it to engage.
- ▶ To ensure that the backrest has engaged, lean firmly against backrest ①.

Folding the seats up/down (3rd row of seats)

General notes

! Make sure that there is nothing on the folded-down seats in the luggage compartment. The luggage compartment must be empty for the third row of seats to be folded up. The seats or the objects in the luggage compartment could, otherwise, be damaged.

Make sure that the seats in the third row are empty and not blocked before folding them down.

The third row of seats consists of two electrically foldable individual seats, which can be lowered into the luggage compartment.

If the seat is not correctly locked in position, the display message: **3rd seat row, right Not locked** appears in the multifunction display.

The switches for folding the left or right-hand seats up and down are marked: **L** for the left-hand seat when viewed in the direction of travel, **R** for the right-hand seat when viewed in the direction of travel.

Folding forwards/back in the rear compartment

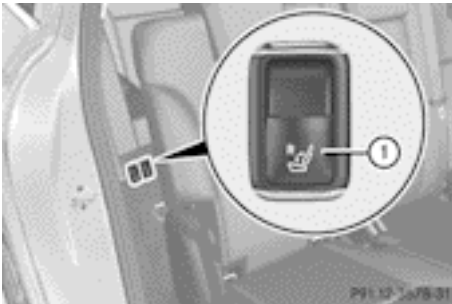

Example: **R** button

- ▶ **To fold down:** fold the right-hand outer seat in the second row of seats forwards (▷ page 106).
- ▶ Briefly pull switch ①.
The seat folds up.

- ▶ **To stop the automatic folding:** briefly pull switch ① again.
- ▶ **To fold down:** briefly press switch ①.
The seat folds down.
- ▶ **To stop the automatic folding:** briefly press switch ① again.

Folding down/up in the luggage compartment

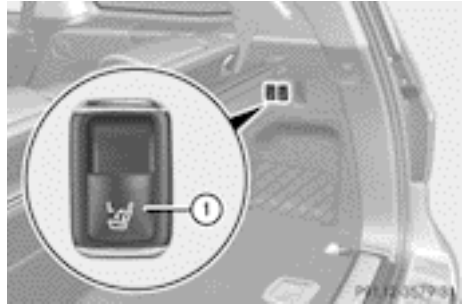

Example: **L** button

- ▶ **To fold down:** fold the right-hand outer seat in the second row of seats forwards (▷ page 106).
- ▶ Briefly press button ①.
The seat folds up.
- ▶ **To stop the automatic folding:** briefly press button ① again.
- ▶ **To fold down:** briefly pull button ①.
The seat folds down.
- ▶ **To stop the automatic folding:** briefly pull button ① again.

Detachable panel (3rd row of seats)

- !** If there are objects underneath the seat, the seat can no longer be folded up or down fully. The seat could be damaged.
Only drive with the panel completely fitted.

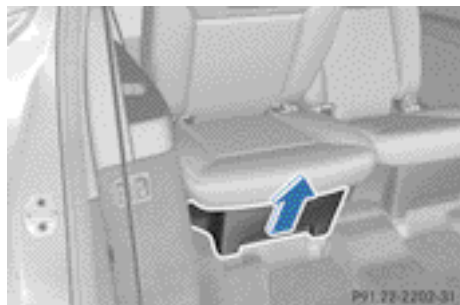

If you drop objects underneath the seats in the third row, you can remove the panel in order to reach beneath the seat.

- ▶ **To open:** fold the corresponding seat up or down (▷ page 105).
- ▶ Once the seat is folded halfway up or down, briefly press the button again to stop the automatic movement.
- ▶ Grasp the panel recess.
- ▶ Pull the panel in the direction of the arrow and remove it.
- ▶ **To close:** fold the corresponding seat up or down (▷ page 105).
- ▶ Once the seat is folded halfway up or down, briefly press the button again to stop the automatic movement.
- ▶ Attach the panel using the guide pins.
- ▶ Push the panel downwards until it engages.
- ▶ Fold the seat up and down fully to check that the panel is seated correctly.

Folding down the seats in the 2nd row manually

General notes

The outer left and right seats of the 2nd row can be folded forwards in order to enter or exit the 3rd row of seats.

- i** Further related subjects:
 - Luggage compartment enlargement (folding the 2nd row of seats forwards) (▷ page 341)
 - Folding the seats in the 3rd row forwards/back (▷ page 105)

Entry position

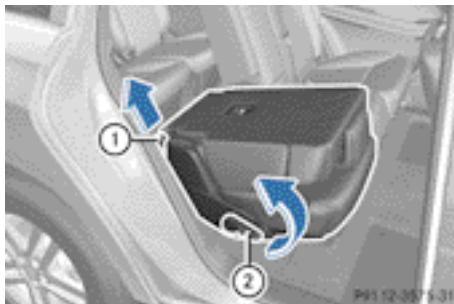

The release handle for the EASY-ENTRY/EXIT feature is located on the entry side on the back of each outer seat in the 2nd row of seats.

- ▶ Move the head restraint to the lowest position (▷ page 103).
- ▶ Pull release handle ② in the direction of the arrow to the pressure point and hold in this position. The backrest folds forwards.

You have two options for folding the seat down fully.

- ▶ Pull release handle ② again in the direction of the arrow to the pressure point and hold it in this position.
- or
- ▶ Pull on release loop ① in the direction of the arrow and hold in this position.
 - ▶ Lift up the seat until it folds forwards.

- i** Vehicles with memory function: The corresponding front seat moves slightly forwards.



Entry position

Exit position**⚠ WARNING**

In order to avoid injury when folding the seat backrest forwards, move your feet and legs back as far as possible so they are not touching the seat when folding it forwards.

In order to avoid an accident or potentially dangerous situation when opening the rear door and getting out of the vehicle, you should always observe the traffic conditions.

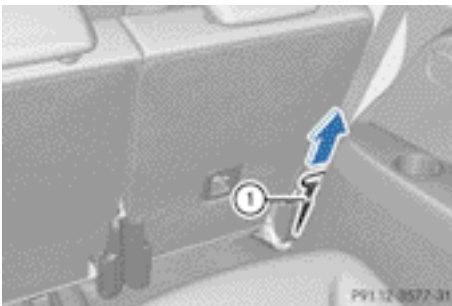

If you wish to exit the 3rd row of seats, fold down the outer seat on the right-hand side as follows.

The release loop for the EASY-ENTRY/EXIT feature is located at the bottom on the back of each outer seat in the 2nd row.

- ▶ Pull on release loop ① in the direction of the arrow and hold in this position. The backrest folds forwards.
- ▶ Pull on release loop ① again in the direction of the arrow and hold in this position.
- ▶ Lift up the seat until it folds forwards.

- ① Vehicles with memory function:
The corresponding front seat moves slightly forwards.



Exit position

- ① Vehicles with memory function:
Call up the programmed seat setting using the memory buttons in order to return the front seat to the saved position.

Moving the outer seats back to the normal position (2nd row of seats)

- ▶ **To lock the seat:** fold back the seat until it engages.
- ▶ Fold back the backrest until it engages.
- ▶ Lean back firmly against the backrest to ensure it is engaged.

Folding down the seats in the 2nd row electrically**General notes**

The outer left and right seats of the 2nd row can be folded down electrically in order to enter or exit the 3rd row of seats.

When at least one of the outer seats of the 2nd row is in the entry/exit position, the display message **2nd seat row, right Not Locked** is shown in the multifunction display.

When you fold the seat and backrest back until they engage, the display message disappears.

i Further related subjects:

- Luggage compartment enlargement (folding the 2nd row of seats forwards) (▷ page 341)
- Folding the seats in the 3rd row forwards/back (▷ page 105)

Folding down the seats

The seats can be folded down electrically if the vehicle is stationary and the respective rear door is open.

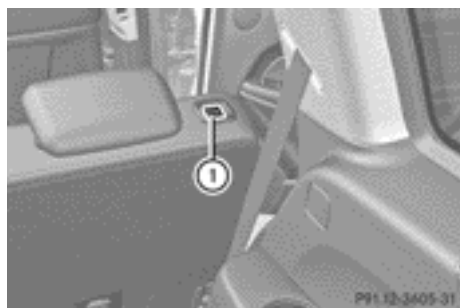

- Press button ①.

The head restraint retracts, the backrest folds forwards and the seat folds forwards.

The seat can be manually returned to its initial position (▷ page 106).

Adjusting the multicontour seat

You can set the multicontour seat using COMAND Online. See the separate COMAND Online Operating Instructions.

Adjusting the 4-way lumbar support

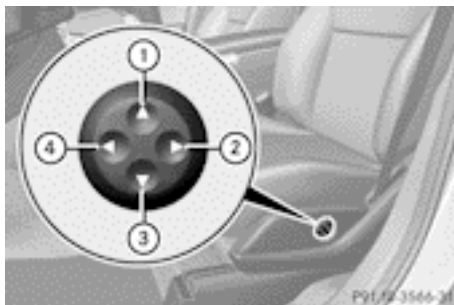

- ① To raise the backrest contour
- ② To soften the backrest contour
- ③ To lower the backrest contour
- ④ To harden the backrest contour

You can adjust the contour of the front seat backrests individually to provide optimum support for your back.

Switching the seat heating on/off

Switching on/off

⚠ WARNING

Repeatedly setting the seat heating to level **3** may result in excessive seat temperatures. The health of passengers that have limited temperature sensitivity or a limited ability to react to excessively high temperatures may be affected or they may even suffer burn-like injuries. Therefore, do not use seat heating level **3** repeatedly.



Driver's and front-passenger seat



Rear seats

The three red indicator lamps in the button indicate the heating level you have selected. The system automatically switches down from level **3** to level **2** after approximately eight minutes.

The system automatically switches down from level **2** to level **1** after approximately ten minutes.

The system automatically switches off approximately 35 minutes after it is set to level **1**.

You can set the distribution of the heated sections of the seat cushion and backrest. You can find information about this in the separate operating instructions.

- ▶ Make sure that the key is in position **1** or **2** in the ignition lock.
- ▶ **To switch on:** press button ① repeatedly until the desired heating level is set.
- ▶ **To switch off:** press button ① repeatedly until all the indicator lamps go out.

- ❗ If the battery voltage is too low, the seat heating may switch off.

Problems with the seat heating

The seat heating has switched off prematurely or cannot be switched on. The vehicle's electrical system voltage is too low because too many electrical consumers are switched on.

- ▶ Switch off electrical consumers that you do not need, such as the rear window heating or interior lighting.

Switching the seat ventilation on/off

Switching on/off



The three blue indicator lamps in the buttons indicate the ventilation level you have selected.

- ▶ Make sure that the key is in position **1** or **2** in the ignition lock.
- ▶ **To switch on:** press button ① repeatedly until the desired ventilation level is set.
- ▶ **To switch off:** press button ① repeatedly until all the indicator lamps go out.

- ❗ If the battery voltage is too low, the seat ventilation may switch off.

- ❗ You can open the side windows and the sliding sunroof using the "Convenience opening" feature (▷ page 90). The seat ventilation of the driver's seat automatically switches to the highest level.

Problems with the seat ventilation

The seat ventilation has switched off prematurely or cannot be switched on. The vehicle's electrical system voltage is too low because too many electrical consumers are switched on.

- ▶ Switch off electrical consumers that you do not need, such as the rear window heating or interior lighting.

Steering wheel

Important safety notes

WARNING

Do not adjust the steering wheel while driving. Adjusting the steering wheel while driving, or driving without the steering wheel adjustment feature locked could cause the driver to lose control of the vehicle.

The electrical steering wheel adjustment feature can be operated at any time. Therefore, do not leave children unattended in the vehicle, or with access to an unlocked vehicle. A child's unsupervised access to a vehicle could result in an accident and/or serious personal injury.

Adjusting the steering wheel manually

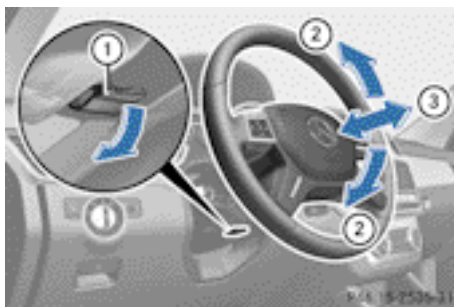

- ① Release lever
 - ② To adjust the steering wheel height
 - ③ To adjust the steering wheel position (fore-and-aft adjustment)
- ▶ Push release lever ① down completely. The steering column is unlocked.
 - ▶ Adjust the steering wheel to the desired position.
 - ▶ Push release lever ① up completely. The steering column is locked.
 - ▶ Check if the steering column is locked. When doing so, try to push the steering wheel up or down or try to move it in the fore-and-aft direction.

Adjusting the steering wheel electrically

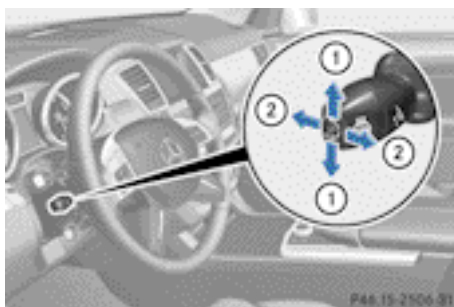

- ① To adjust the steering wheel height
- ② To adjust the steering wheel position (fore-and-aft adjustment)

i Further related subjects:

- EASY-ENTRY/EXIT feature (▷ page 111)
- storing settings (▷ page 115)

Steering wheel heating

Switching on/off

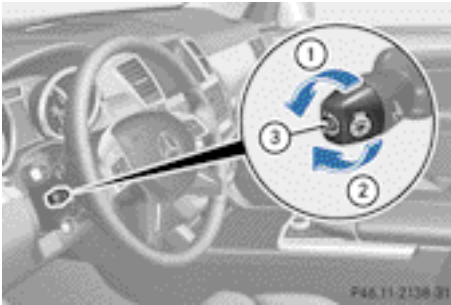

- ▶ Make sure that the key is in position **2** in the ignition lock.
- ▶ **To switch on/off:** turn the lever in the direction of arrow **1** or **2**. Indicator lamp **3** lights up or goes out.

Vehicles without KEYLESS-GO: when you remove the key from the ignition lock, the steering wheel heating is switched off.

Vehicles with KEYLESS-GO: when you switch off the ignition and open the driver's door, the steering wheel heating is switched off.

Problems with the steering wheel heating

The steering wheel heating has switched itself off prematurely or cannot be switched on. The vehicle's electrical system voltage is too low because too many electrical consumers are switched on.

- ▶ Switch off electrical consumers that you do not need, such as the rear window heating or interior lighting.

EASY-ENTRY/EXIT feature

Important safety notes

⚠ WARNING

Make sure that nobody can become trapped when you activate the EASY-ENTRY/EXIT feature.

If there is a risk of someone becoming trapped, stop the adjustment procedure. To halt the procedure:

- press the steering column adjustment button.
- briefly press one of the memory function position buttons.

The steering column stops moving immediately.

Do not keep the memory function position button pressed down, otherwise the memory function will start and the steering wheel and seat will begin to move.

Never leave children unsupervised in the vehicle. They could open the driver's door and thereby unintentionally activate the EASY-ENTRY feature and become trapped.

The EASY-ENTRY/EXIT feature makes getting in and out of your vehicle easier.

You can activate and deactivate the EASY-ENTRY/EXIT feature in the on-board computer (▷ page 285).

Position of the steering wheel when the EASY-ENTRY/EXIT feature is active

The steering wheel tilts upwards if you:

- remove the key from the ignition lock
- open the driver's door and KEYLESS-GO is in position **1**
- open the driver's door and the key is in position **0** or **1** in the ignition lock

- i** The steering wheel only moves upwards if it has not already reached the upper end stop.

Position of the steering wheel for driving

The steering wheel is moved to the previously set position if:

- the driver's door is closed and
- you insert the key into the ignition lock or
- you press the Start/Stop button once on vehicles with KEYLESS-GO.

If you close the driver's door with the key inserted into the ignition lock, the steering wheel is automatically moved to the previously set position.

The last position of the steering wheel is stored when you switch off the ignition or when you store the setting with the memory function (▷ page 115).

Crash-responsive EASY-EXIT feature

If the crash-responsive EASY-EXIT feature is triggered in an accident, the steering column will move upwards when the driver's door is opened. This occurs irrespective of the position of the key in the ignition lock. This makes it easier to exit the vehicle and rescue the occupants.

The crash-responsive EASY-EXIT feature is only operational if the EASY-EXIT/ENTRY feature is activated in the on-board computer (▷ page 285).

Mirrors

Rear-view mirror

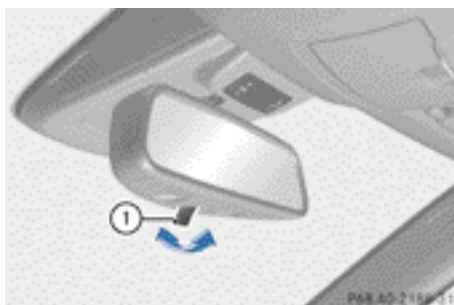

- ▶ **Anti-dazzle mode:** flick anti-dazzle switch ① forwards or back.

Exterior mirrors

Adjusting the exterior mirrors

WARNING

The exterior mirrors reduce the size of the image. Objects are actually closer than they appear. You could misjudge the distance from vehicles driving behind and cause an accident, e.g. when changing lane. For this reason, make sure of the actual distance from the vehicle driving behind by glancing over your shoulder.



- ▶ Make sure that the key is in position 1 or 2 in the ignition lock.
- ▶ Press button ① for the left-hand exterior mirror or button ② for the right-hand exterior mirror.
The indicator lamp in the corresponding button lights up in red.
The indicator lamp goes out again after some time. You can adjust the selected mirror using adjustment button ③ as long as the indicator lamp is lit.
- ▶ Press adjustment button ③ up, down, or to the left or right until you have adjusted the exterior mirror to the correct position.
You should have a good overview of traffic conditions.

The convex exterior mirrors provide a larger field of vision.

The exterior mirrors are automatically heated if the rear window heating is switched on and the outside temperature is low.

Folding the exterior mirrors in or out electrically



- ▶ Make sure that the key is in position 1 or 2 in the ignition lock.
- ▶ Briefly press button ①.
Both exterior mirrors fold in or out.
- ❗ Make sure that the exterior mirrors are always folded out fully while driving. They could otherwise vibrate.

Setting the exterior mirrors

If the battery has been disconnected or completely discharged, the exterior mirrors must be reset. The exterior mirrors will otherwise not fold in when you select the "Fold in mirrors when locking" function in the on-board computer (▷ page 285).

- ▶ Make sure that the key is in position 1 in the ignition lock.
- ▶ Briefly press button ①.

Folding the exterior mirrors in/out automatically

If the "Fold in mirrors when locking" function is activated in the on-board computer: (▷ page 285)

- the exterior mirrors fold in automatically as soon as you lock the vehicle from the outside.
- the exterior mirrors fold out again automatically as soon as you unlock the vehicle and then open the driver's or front-passenger door.

Exterior mirror pushed out of position

If an exterior mirror has been pushed out of position, proceed as follows:

- ▶ **Vehicles without electrically folding exterior mirrors:** move the exterior mirror into the correct position manually.
- ▶ **Vehicles with electrically folding exterior mirrors:** press and hold button for folding the mirrors ① (▷ page 113) until you hear a click and then the mirror engage in position.
The mirror housing is engaged again and you can adjust the exterior mirrors as usual (▷ page 112).

Automatic anti-dazzle mirrors

⚠ WARNING

If incident light from headlamps is prevented from striking the sensor in the rear-view mirror, for instance, by luggage piled too high in the vehicle, the mirror's automatic anti-dazzle function will not operate.

Incident light could then blind you. This may distract you from the traffic conditions and, as a result, you may cause an accident.

The rear-view mirror and the exterior mirror on the driver's side automatically go into anti-dazzle mode if the following conditions are met simultaneously:

- the ignition is switched on and
- incident light from headlamps strikes the sensor in the rear-view mirror.

The mirrors do not go into anti-dazzle mode if reverse gear is engaged or if the interior lighting is switched on.

Parking position for the exterior mirror on the front-passenger side

Setting and storing the parking position

Using reverse gear

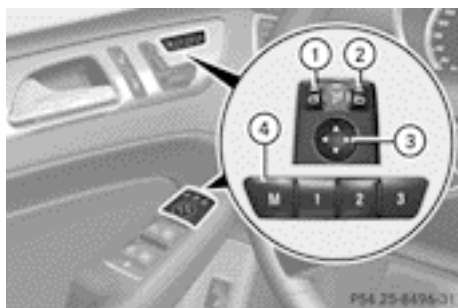

- ① Button for the driver's side exterior mirror
- ② Button for the passenger side exterior mirror
- ③ Adjustment button
- ④ Memory button **M**

You can set the front-passenger side exterior mirror so that you can see the rear wheel on that side as soon as you engage reverse gear. You can store this position.

- ▶ Make sure that the vehicle is stationary and that the key is in position **2** in the ignition lock.
- ▶ Press button ② for the exterior mirror on the front-passenger side.
- ▶ Engage reverse gear. The exterior mirror on the front-passenger side moves to the preset parking position.
- ▶ Use adjustment button ③ to adjust the exterior mirror to a position that allows you to see the rear wheel and the kerb. The parking position is stored.

i If you shift the transmission to another position, the exterior mirror on the front-passenger side returns to the driving position.

Using the memory button

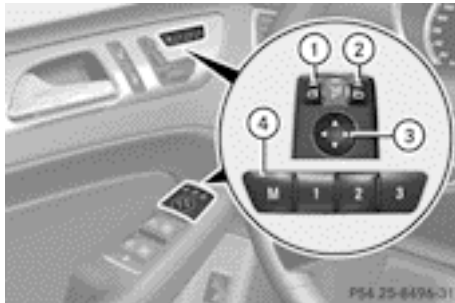

- ① Button for the driver's side exterior mirror
- ② Button for the front-passenger side exterior mirror
- ③ Adjustment button
- ④ Memory button **M**

You can set the front-passenger side exterior mirror so that you can see the rear wheel on that side as soon as you engage reverse gear. This setting can be stored using memory button **M** ④.

- ▶ Make sure that the key is in position **2** in the ignition lock.
- ▶ With the exterior mirror on the front-passenger side activated, use adjustment button **③** to adjust the exterior mirror. In the exterior mirror, the rear wheel and the kerb should be visible.
- ▶ Press memory button **M** **④** and one of the arrows on adjustment button **③** within three seconds.
The parking position is stored if the exterior mirror does not move.
- ▶ If the mirror moves out of position, repeat the steps.

Calling up a stored parking position setting

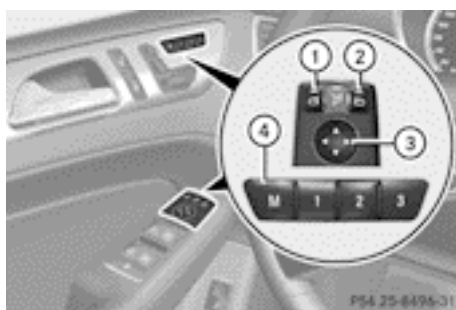

- ① Button for the driver's side exterior mirror
 - ② Button for the passenger side exterior mirror
 - ③ Adjustment button
 - ④ Memory button **M**
- ▶ Turn the key to position **2** in the ignition lock.
 - ▶ Adjust the exterior mirror on the front-passenger side using button **②**.
 - ▶ Engage reverse gear.
The exterior mirror on the front-passenger side moves to the stored parking position.

The exterior mirror on the front-passenger side moves back to its original position:

- as soon as you exceed a speed of 15 km/h
- if you press button **①** for the exterior mirror on the driver's side

Memory function

Storing settings

⚠ WARNING

Only use the memory function on the driver's side when the vehicle is stationary. You could otherwise be distracted from the traffic conditions by the steering wheel and seat moving of their own accord, and as a result, cause an accident.

⚠ WARNING

The memory function can still be used when the key has been removed. For this reason, children should never be left unsupervised in the vehicle. They could otherwise become trapped when adjusting the seat or the steering wheel.

With the memory function, you can store up to three different settings, e.g. for three different people.

The following settings are stored as a single memory preset:

- position of the seat, backrest and head restraint
- driver's side: steering wheel position
- driver's side: position of the exterior mirrors on the driver's and front-passenger sides

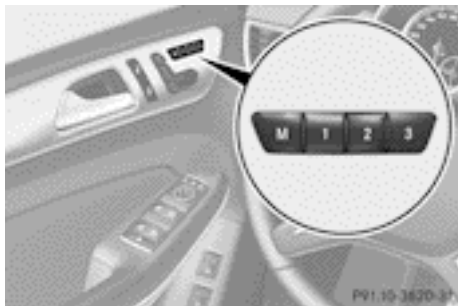

- ▶ Adjust the seat (> page 102).
- ▶ On the driver's side, adjust the steering wheel (> page 110) and the exterior mirrors (> page 112).
- ▶ Press the **M** memory button and then press storage position button **1**, **2** or **3** within three seconds.
The settings are stored in the selected pre-set position. A tone sounds when the settings have been completed.

Calling up a stored setting

- ▶ Press and hold the relevant storage position button **1**, **2** or **3** until the seat, steering wheel and exterior mirrors are in the stored position.
- i** The setting procedure is interrupted as soon as you release the storage position button.

Useful information	118
Exterior lighting	118
Interior lighting	126
Replacing bulbs	128
Windscreen wipers	131

Useful information

- i** This Owner's Manual describes all models, series and optional equipment for your vehicle that were available at the time of going to press. National variations are possible. Note that your vehicle may not be equipped with all of the functions described. This is also the case for systems and functions relevant to safety.
- i** Read the information on qualified specialist workshops: (▷ page 25).

Exterior lighting

Important safety notes

For reasons of safety, Mercedes-Benz recommends that you drive with the lights switched on even during the daytime. In some countries, operation of the headlamps varies due to legal requirements and self-imposed obligations.

Driving abroad

General notes

If your journey takes you to countries where vehicles are driven on the opposite side of the road to the country in which the vehicle is registered, your headlamps must be switched to symmetrical dipped beam as soon as possible after crossing the border. This prevents oncoming traffic from being dazzled. Symmetrical lights do not illuminate as large an area of the edge of the carriageway.

Vehicles with halogen headlamps

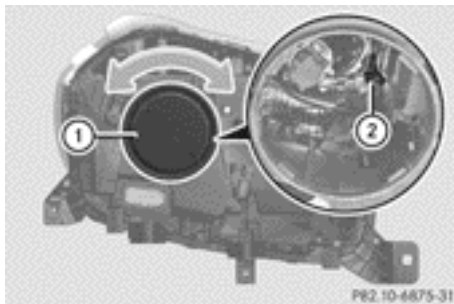

- ▶ Turn protective cap ① anti-clockwise and remove it.
- ▶ Push switchover lever ② down.
- ▶ Insert protective cap ① and turn it clockwise.

Convert the headlamps back to asymmetrical dipped beam as soon as possible after returning across the border.

Vehicles with Intelligent Light System

- ▶ Before crossing the border, set the headlamps to symmetrical dipped beam and when returning to asymmetrical dipped-beam using the "Dipped-beam headlamps for driving on the right or left" function on the on-board computer (▷ page 281).

If the headlamps are converted to symmetrical dipped beam, the "motorway mode" and "extended range foglamps" functions are not available.

Setting the exterior lighting

Setting options

Exterior lighting can be set using the:

- light switch
- combination switch (▷ page 121)
- on-board computer (▷ page 280)

Light switch

Operation

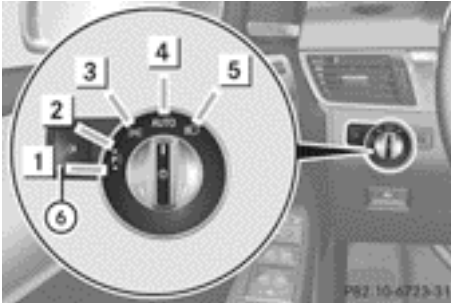

- 1 Left-hand parking lamps
- 2 Right-hand parking lamps
- 3 Side lamps, licence plate and instrument cluster lighting
- 4 **AUTO** Automatic headlamp mode, controlled by the light sensor
- 5 Dipped-beam/main-beam headlamps
- 6 Rear foglamp

If you hear a warning tone when you leave the vehicle, the lights may still be switched on.

- Turn the light switch to **AUTO**.

The exterior lighting (except the side lamps/parking lamps) switches off automatically if you:

- remove the key from the ignition lock
- open the driver's door with the key in position **0**

Automatic headlamp mode

WARNING

If the light switch is set to **AUTO** and it is foggy, snowing or there is poor visibility, the dipped-beam headlamps will not come on automatically. This could endanger you and others. In such situations turn the light switch to .

The automatic headlamp feature is only an aid. The driver is responsible for the vehicle's lighting at all times.

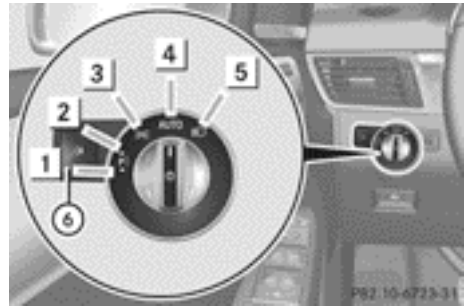

- 1 Left-hand parking lamps
- 2 Right-hand parking lamps
- 3 Side lamps, licence plate and instrument cluster lighting
- 4 **AUTO** Automatic headlamp mode, controlled by the light sensor
- 5 Dipped-beam/main-beam headlamps
- 6 Rear foglamp

AUTO is the preferred light switch setting. The light setting is automatically selected according to the brightness of the ambient light (exception: poor visibility due to weather conditions such as fog, snow or spray):

- Key in position **1** in the ignition lock: the side lamps are switched on or off automatically depending on the brightness of the ambient light.
- With the engine running: if you have activated the daytime driving lights function via the on-board computer, the daytime driving lights or the dipped-beam headlamps and side lamps are switched on or off automatically depending on the brightness of the ambient light.

- **To switch on automatic headlamp mode:** turn the light switch to **AUTO**.

The daytime driving lights improve the visibility of your vehicle during the day. Here, the daytime driving lights function must be switched on via the on-board computer (▷ page 280).

When the dipped-beam headlamps are switched on, the green indicator lamp

in the instrument cluster lights up and the daytime driving lights go out or are dimmed.





Dipped-beam headlamps

⚠ WARNING

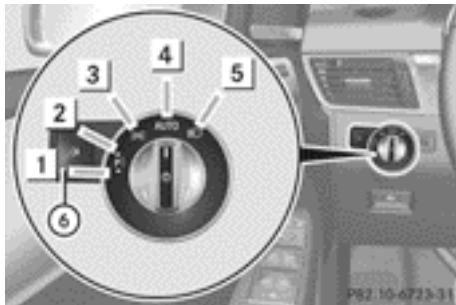

If the light switch is set to **AUTO** and it is foggy, snowing or there is poor visibility, the dipped-beam headlamps will not come on automatically. This could endanger you and others. In such situations turn the light switch to .

The automatic headlamp feature is only an aid. The driver is responsible for the vehicle's lighting at all times.







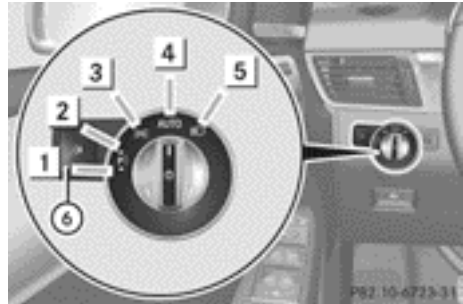

- 1  Left-hand parking lamps
- 2  Right-hand parking lamps
- 3  Side lamps, licence plate and instrument cluster lighting
- 4 **AUTO** Automatic headlamp mode, controlled by the light sensor
- 5  Dipped-beam/main-beam headlamps
- 6  Rear foglamp

Even if the light sensor does not detect that it is dark, the side lamps and dipped-beam headlamps switch on when the key is inserted into the ignition lock and the light switch is set to the  position. This is a particularly useful function in the event of rain and fog.





- ▶ **To switch on the dipped-beam headlamps:** turn the key in the ignition lock to position **2** or start the engine.
- ▶ Turn the light switch to . The green  indicator lamp in the instrument cluster lights up.

Rear foglamp





- 1  Left-hand parking lamps
- 2  Right-hand parking lamps
- 3  Side lamps, licence plate and instrument cluster lighting
- 4 **AUTO** Automatic headlamp mode, controlled by the light sensor
- 5  Dipped-beam/main-beam headlamps
- 6  Rear foglamp

The rear foglamp improves visibility of your vehicle for the traffic behind in the event of heavy fog. Please take note of the country-specific regulations for the use of rear foglamps.





- ▶ **To switch on the rear foglamp:** turn the key in the ignition lock to position **2** or start the engine.
- ▶ Turn the light switch to  or **AUTO**.
- ▶ Press the  button. The yellow  indicator lamp in the instrument cluster lights up.
- ▶ **To switch off the rear foglamp:** press the  button. The yellow  indicator lamp in the instrument cluster goes out.

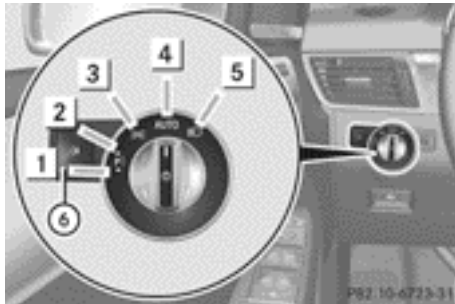

Side lamps

- If the battery has been excessively discharged, the side lamps or parking lamps are automatically switched off to enable the next engine start. Always park your vehicle safely and sufficiently lit according to legal standards. Avoid the continuous

use of the  side lamps for several hours. If possible, switch on the  right or the  left parking lamp.





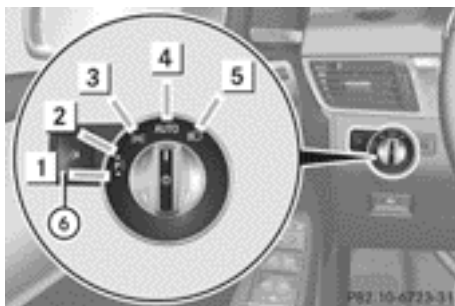

- 1  Left-hand parking lamps
- 2  Right-hand parking lamps
- 3  Side lamps, licence plate and instrument cluster lighting
- 4 **AUTO** Automatic headlamp mode, controlled by the light sensor
- 5  Dipped-beam/main-beam headlamps
- 6  Rear fog lamp

► **To switch on:** turn light switch to . The green  indicator lamp in the instrument cluster lights up.



Parking lamps



- 1  Left-hand parking lamps
- 2  Right-hand parking lamps
- 3  Side lamps, licence plate and instrument cluster lighting
- 4 **AUTO** Automatic headlamp mode, controlled by the light sensor

- 5  Dipped-beam/main-beam headlamps
- 6  Rear fog lamp

Switching on the parking lamps ensures the corresponding side of the vehicle is illuminated.

- **To switch on the parking lamps:** the key is not in the ignition lock or it is in position 0.
- Turn the light switch to  (left-hand side of the vehicle) or  (right-hand side of the vehicle).

Combination switch

Turn signals

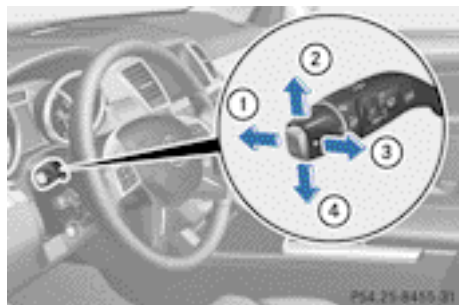

- 1 Main-beam headlamps
- 2 Turn signal, right
- 3 Headlamp flasher
- 4 Turn signal, left

- **To indicate briefly:** press the combination switch briefly to the pressure point in the direction of arrow ② or ④. The corresponding turn signal flashes three times.
- **To indicate:** press the combination switch beyond the pressure point in the direction of arrow ② or ④.

Main-beam headlamps

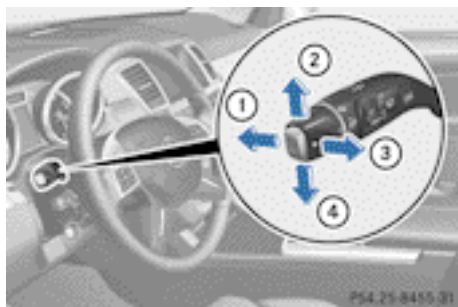

- ① Main-beam headlamps
- ② Turn signal, right
- ③ Headlamp flasher
- ④ Turn signal, left

► **To switch on the main-beam headlamps:** turn the key in the ignition lock to position **2** or start the engine.

► Turn the light switch to  or **AUTO**.

► Press the combination switch beyond the pressure point in the direction of arrow **①**.

In the **AUTO** position, the main-beam headlamps are only switched on when it is dark and the engine is running.

The blue  indicator lamp in the instrument cluster lights up when the main-beam headlamps are switched on.

► **To switch off the main-beam headlamps:** move the combination switch back to its normal position.

The blue  indicator lamp in the instrument cluster goes out.

i Vehicles with Adaptive Highbeam Assist: when Adaptive Highbeam Assist is active, it controls activation of the main-beam headlamps (► page 124).

Headlamp flasher

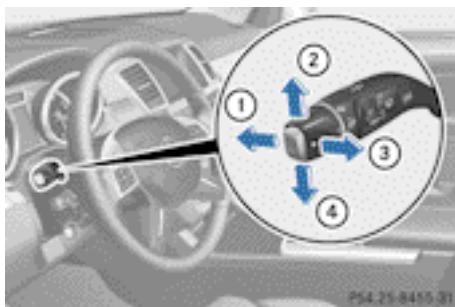

- ① Main-beam headlamps
- ② Turn signal, right
- ③ Headlamp flasher
- ④ Turn signal, left

► **To switch on:** turn the key in the ignition lock to position **1** or **2**, or start the engine.

► Pull the combination switch in the direction of arrow **③**.

Hazard warning lamps



► **To switch on the hazard warning lamps:** press button **①**.

All turn signals flash. If you now switch on a turn signal using the combination switch, only the turn signal lamp on the corresponding side of the vehicle will flash.

► **To switch off the hazard warning lamps:** press button **①**.

The hazard warning lamps automatically switch on if:

- an airbag is deployed.
- the vehicle decelerates rapidly from a speed of more than 70 km/h and comes to a standstill.

The hazard warning lamps switch off automatically if the vehicle reaches a speed of over 10 km/h again after a full brake application.

- i** The hazard warning lamps still operate if the ignition is switched off.

Headlamp cleaning system

The headlamps are cleaned automatically if the "Wipe with washer fluid" function is operated five times (▷ page 131) while the lights are on and the engine is running. When you switch off the ignition, the automatic headlamp cleaning system is reset and counting is resumed from 0.

Intelligent Light System

General notes

The Intelligent Light System is a system that adjusts the headlamps automatically to suit the prevailing driving and weather conditions. It offers advanced functions for improved illumination of the road surface, e.g. depending on the vehicle speed or weather conditions. The system includes the active light function, cornering light function, motorway mode and extended range foglamps. The system is only active when it is dark.

You can activate or deactivate the "Intelligent Light System" using the on-board computer (▷ page 281).

Active light function

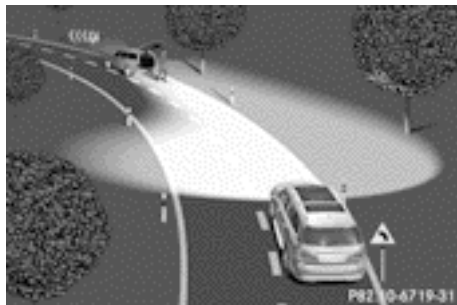

The active light function is a system that moves the headlamps according to the steering movements of the front wheels. In this way, relevant areas remain illuminated while driving. This allows you to recognise pedestrians, cyclists and animals.

Active: when the lights are switched on.

Cornering light function



The cornering light function improves the illumination of the road over a wide angle in the direction you are turning, enabling better visibility in tight bends, for example. It can only be activated when the dipped-beam headlamps are switched on.

Active:

- if you are driving at speeds below 40 km/h and the turn signal is activated or the steering wheel is turned.
- if you are driving at speeds between 40 km/h and 70 km/h and turn the steering wheel.

Not active: if you are driving at speeds above 40 km/h or switch off the turn signal or turn the steering wheel to the straight-ahead position.

The cornering lamp may remain lit for a short time, but is automatically switched off after no more than three minutes.

Motorway mode



Motorway mode increases the range of the beam.

Active: if you are driving at a speed above 110 km/h and do not make any large steering movements for at least 1000 m or if you are driving at a speed above 130 km/h.

Not active: if you are driving at speeds below 80 km/h following activation.

Extended range foglamps

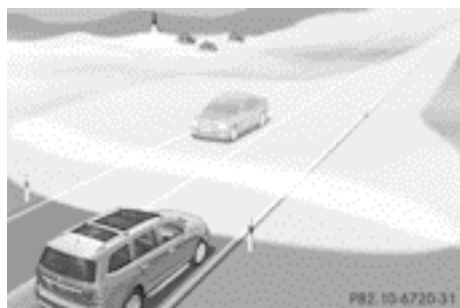

The extended range foglamps reduce the glare experienced by the driver and improve the illumination of the edge of the carriageway.

Active: if you are driving at speeds below 70 km/h and you switch on the rear foglamp

Not active: if, following activation, you are driving at speeds above 100 km/h or if you switch off the rear foglamp.

Off-road lights

The off-road lights facilitate the early recognition of objects/obstacles when driving off-road thanks to a symmetrical, wider and brighter distribution of light from the dipped-beam headlamps.

Active: when driving at speeds no faster than 50 km/h and the off-road program selector wheel is in position 1 or 2.

Not active: when driving at speeds above 50 km/h.

When the off-road lights are switched on, the cornering light function is permanently activated, the active light function is deactivated and the headlamp range control is set to static mode.

Adaptive Highbeam Assist

Important safety notes

WARNING

Adaptive Highbeam Assist is only an aid designed to assist driving. The driver is responsible for adjusting the vehicle's lighting to the prevailing light, vision and traffic conditions.

The system may be impaired or deactivated:

- if there is poor visibility, e.g. due to snow, rain, fog or spray
- if the area of the windscreen around the optical sensor is dirty, misted up or covered up, e.g. by a sticker

The system may not recognise the following road users:

- road users that have no lighting, e.g. pedestrians
- road users that have poor lighting, e.g. cyclists
- road users whose lighting is not clearly visible, e.g. road users behind a crash barrier
- on rare occasions: road users that have lights that may be recognised too late or not at all

The automatic main-beam headlamps will not be deactivated, or they may be activated despite road users travelling in front of or approaching the vehicle.

Thus, you could cause an accident and injure yourself and others. Always observe traffic conditions and, if necessary, dip the lights manually.



You can use this function to set the headlamps to change between dipped beam and main beam automatically. The system recognises vehicles with their lights on, either approaching from the opposite direction or travelling in front of your vehicle, and consequently switches the headlamps from main beam to dipped beam.

The system automatically adapts the dipped-beam headlamp range depending on the dis-

tance to the other vehicle. Once the system no longer detects any other vehicles, it reactivates the main-beam headlamps.

The system's optical sensor is located behind the windscreen near the overhead control panel.

Switching Adaptive Highbeam Assist on/off

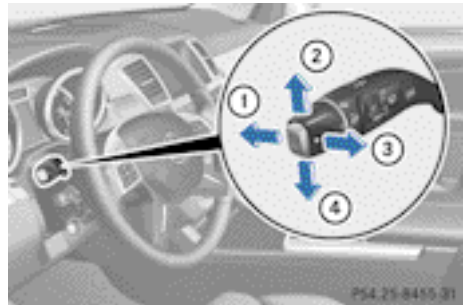

- ① Main-beam headlamps
- ② Turn signal, right
- ③ Headlamp flasher
- ④ Turn signal, left

► **To activate:** activate the Adaptive Highbeam Assist function using the on-board computer (▷ page 281).

► Turn the light switch to **AUTO**.

► Press the combination switch beyond the pressure point in the direction of arrow ① (▷ page 121).



The  indicator lamp in the multifunction display lights up if it is dark and the light sensor activates the dipped-beam headlamps.

If you are driving at speeds above 45 km/h:

the headlamp range is set automatically depending on the distance between the vehicle and other road users.

If you are driving at speeds above 55 km/h and no other road users are recognised:

the main-beam headlamps are switched on automatically. The  indicator lamp in the instrument cluster also lights up.

If you are driving at speeds below 45 km/h or other road users are recognised or the roads are adequately lit: the main-beam headlamps are switched off automatically. The  indicator lamp in the instrument cluster goes out. The  indicator lamp in the multifunction display remains lit.

- ▶ **To deactivate:** move the combination switch back to its normal position. The  indicator lamp in the instrument cluster goes out.

Headlamps misted up on the inside

The headlamps may mist up on the inside if there is high atmospheric humidity.

- ▶ Switch on the lights and drive off. The level of moisture diminishes, depending on the length of the journey and the weather conditions (humidity and temperature).

If the level of moisture does not diminish:



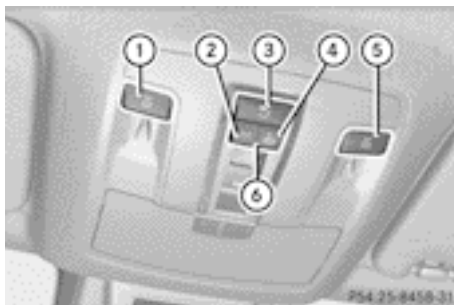

- ▶ Have the headlamps checked at a qualified specialist workshop.

Interior lighting

Overview of interior lighting



Overhead control panel

- ①  To switch the left-hand front reading lamp on/off
- ②  To switch the front interior lighting on
- ③  To switch the rear interior lighting on/off
- ④  To switch the front interior lighting/automatic interior lighting control off
- ⑤  To switch the right-hand front reading lamp on/off
- ⑥ To switch the automatic interior lighting control on

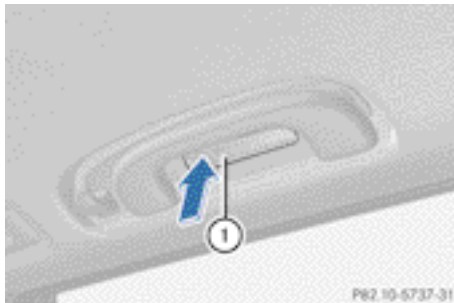

Rear overhead control panel (second row of seats)

- ① To switch the reading lamp on/off

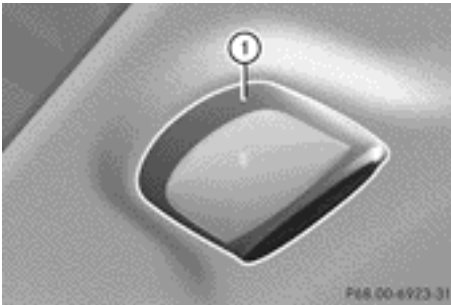

Rear overhead control panel (third row of seats)

- ① Reading lamp

Interior lighting control

General notes



In order to prevent the vehicle's battery from discharging, the interior lighting functions are automatically deactivated after some time except for when the key is in position **2** in the ignition lock.

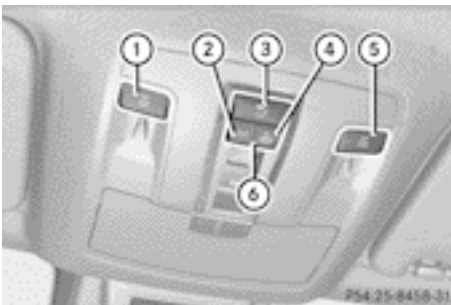

The colour and brightness of the ambient lighting may be set using the on-board computer (▷ page 281).

Automatic interior lighting control



Overhead control panel

- ①  To switch the left-hand front reading lamp on/off
- ②  To switch the front interior lighting on
- ③  To switch the rear interior lighting on/off

- ④  To switch the front interior lighting/automatic interior lighting control off
- ⑤  To switch the right-hand front reading lamp on/off
- ⑥ To switch the automatic interior lighting control on

► **To switch on:** set the switch to centre position ⑥.

► **To switch off:** set the switch to the  position.

The interior lighting automatically switches on if you:





- unlock the vehicle
- open a door
- remove the key from the ignition lock

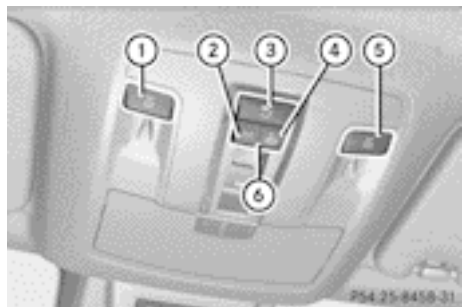



The interior lighting is activated for a short time when the key is removed from the ignition lock. You can activate this delayed switch-off using the on-board computer (▷ page 282).

Manual interior lighting control



Overhead control panel

- ①  To switch the left-hand front reading lamp on/off
- ②  To switch the front interior lighting on
- ③  To switch the rear interior lighting on/off
- ④  To switch the front interior lighting/automatic interior lighting control off

- ⑤  To switch the right-hand front reading lamp on/off
- ⑥ To switch the automatic interior lighting control on
- ▶ **To switch on the front interior lighting:** set the switch to the  position.
- ▶ **To switch off the interior lighting:** set the switch to the  position or (if the door is closed) to the centre position.
- ▶ **To switch the rear interior lighting on/off:** press the  button.
- ▶ **To switch the reading lamps on/off:** press the  button.

Crash-responsive emergency lighting

The interior lighting is activated automatically if the vehicle is involved in an accident.

- ▶ **To switch off the crash-responsive emergency lighting:** press the hazard warning lamp button.

or

- ▶ Lock and then unlock the vehicle using the key.

Replacing bulbs

Important safety notes

Xenon bulbs

DANGER

Xenon bulbs are under high voltage. If you touch the electrical contacts of a xenon bulb, you could suffer an electric shock and be seriously or even fatally injured. For this reason, do not remove the cover of xenon bulbs.

Do not change the xenon bulbs yourself, but have them replaced at a qualified workshop.

If your vehicle is equipped with xenon bulbs, you can recognise this by the following: the cone of light from the xenon bulbs moves from the top to the bottom and back again when you start the engine. For this to be

observed, the lights must be switched on before starting the engine.

Bulbs and lamps are an important aspect of vehicle safety. You must therefore make sure that these function correctly at all times. Have the headlamp setting checked regularly.

Other bulbs

WARNING

Bulbs and lamps can be very hot. You should therefore allow them to cool down before you change them. Otherwise, you could be burned if you touch them.

Keep bulbs out of the reach of children. Otherwise, they could damage the bulbs, for example, and injure themselves.

Never use a bulb which has been dropped. Such a bulb may break or even explode and injure you.

Halogen bulbs are pressurised and can explode when you change them, particularly if they are very hot. You should therefore wear eye protection and gloves when you are changing them.

There are bulbs other than the xenon bulbs that you cannot replace. Replace only the bulbs listed (▷ page 129). Have the bulbs that you cannot replace yourself changed at a qualified specialist workshop.

If you require assistance changing bulbs, consult a qualified specialist workshop.

Do not touch the glass tube of new bulbs with your bare hands. Even minor contamination can burn into the glass surface and reduce the service life of the bulbs. Always use a lint-free cloth or only touch the base of the bulb when fitting.

Only use bulbs of the correct type.

If the new bulb still does not light up, consult a qualified specialist workshop.

Bulbs and lamps are an important aspect of vehicle safety. You must therefore make sure that these function correctly at all times. Have the headlamp setting checked regularly.

Overview of bulb replacement – bulbs

You can replace the following bulbs. The details for the bulb type can be found in the legend.

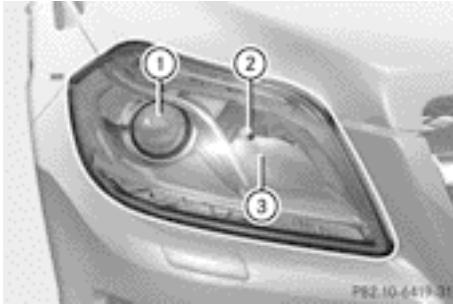

Halogen headlamps

- ① Dipped-beam headlamp: H7 55 W
- ② Main-beam headlamp: H7 55 W
- ③ Side lamps/parking lamp: W 5 W BV

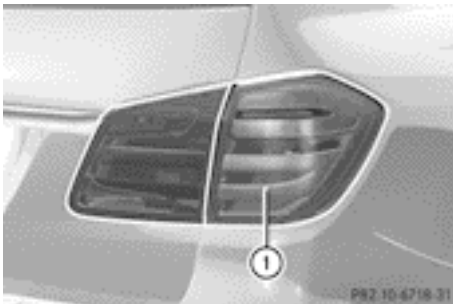

Tail lamps

- ① Brake lamp: P 21 W-L

Replacing the front bulbs

Fitting/removing the cover on the front wheel arch

You must remove the cover from the front wheel housing before you can change the front bulbs.

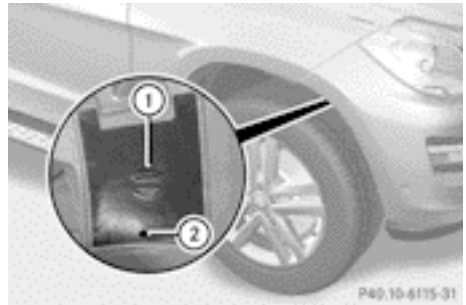

- ▶ **To remove:** switch off the lights.
- ▶ Turn the front wheels inwards.
- ▶ Remove securing pin ② using a suitable tool.
- ▶ Slide cover ① up and remove it.
- ▶ **To fit:** insert cover ① again and slide it down until it engages.
- ▶ Insert securing pin ②.

Dipped-beam headlamps (halogen headlamps)

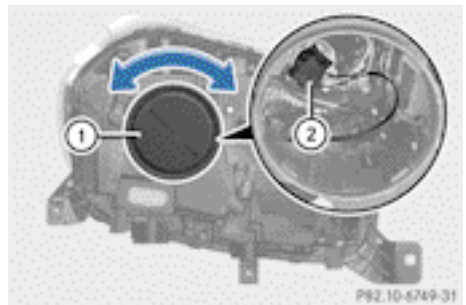

- ▶ Remove the cover in the front wheel arch (> page 129).
- ▶ Turn housing cover ① anti-clockwise and pull it out.
- ▶ Turn bulb holder ② anti-clockwise and pull it out.
- ▶ Take the bulb out of bulb holder ②.
- ▶ Insert the new bulb into bulb holder ②.
- ▶ Insert bulb holder ② into the lamp and turn it clockwise.

- ▶ Align housing cover ① and turn it clockwise until it engages.
- ▶ Replace the cover in the front wheel arch (▷ page 129).

Main-beam headlamps (halogen headlamps)

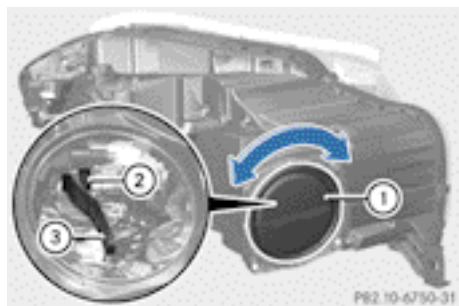

- ▶ Switch off the lights.
- ▶ Open the bonnet.
- ▶ Turn housing cover ① anti-clockwise and pull it out.
- ▶ Pull lever ③ upwards and remove bulb holder ②.
- ▶ Take the bulb out of bulb holder ②.
- ▶ Insert the new bulb into bulb holder ②.
- ▶ Simultaneously press bulb holder ② and pull lever ③ downwards.
- ▶ Align housing cover ① and turn it clockwise until it engages.

Side lamps/parking lamps (halogen headlamps)

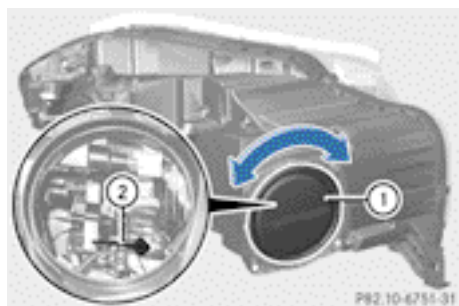

- ▶ Switch off the lights.
- ▶ Open the bonnet.
- ▶ Turn housing cover ① anti-clockwise and pull it out.
- ▶ Pull out bulb holder ②.
- ▶ Take the bulb out of bulb holder ②.
- ▶ Insert the new bulb into bulb holder ②.
- ▶ Insert bulb holder ②.
- ▶ Align housing cover ① and turn it clockwise until it engages.

Replacing the rear bulbs

Opening and closing the service flap

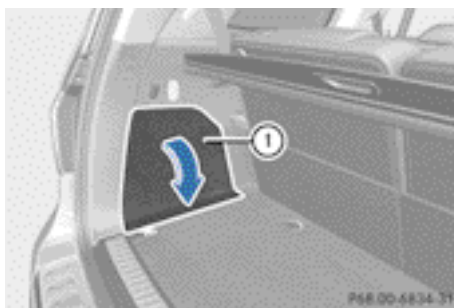

Left-hand service flap

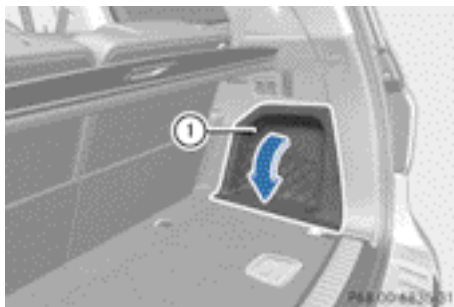

Right-hand service flap

You must open the service flap in the luggage compartment before you can replace the bulbs in the brake lamp.

- ▶ **To open:** release service flap ① at the top, e.g. with a screwdriver, and swing it downward in the direction of the arrow.
- ▶ Right side: remove the first-aid kit beforehand and pull the luggage net down.
- ▶ **To close:** reinsert service flap ①.

Brake lamp

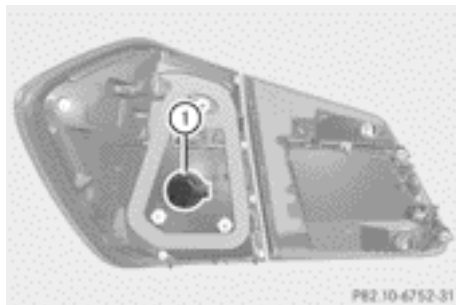

- ▶ Switch off the lights.
- ▶ Open the luggage compartment.
- ▶ Open the service flap (▷ page 130).
- ▶ Turn bulb holder ① anti-clockwise and remove it.
- ▶ Take bulb out of bulb holder ①.
- ▶ Insert the new bulb into bulb holder ①.
- ▶ Insert bulb holder ① into the lamp and turn it clockwise.
- ▶ Close the service flap (▷ page 130).

Windscreen wipers

Switching the windscreen wipers on/off

⚠ WARNING

The windscreen will not longer be wiped properly if the wiper blades are worn. This could prevent you from observing the traffic conditions, thereby causing an accident. Replace

the wiper blades twice a year, ideally in spring and autumn.

- ❗ Do not operate the windscreen wipers when the windscreen is dry, as this could damage the wiper blades. Moreover, dust that has collected on the windscreen can scratch the glass if wiping takes place when the windscreen is dry.

If it is necessary to switch on the windscreen wipers in dry weather conditions, always operate them using washer fluid.

- ❗ If the windscreen wipers leave smears on the windscreen after the vehicle has been washed in an automatic car wash, this may be due to wax or other residue. Clean the windscreen with washer fluid after an automatic car wash.

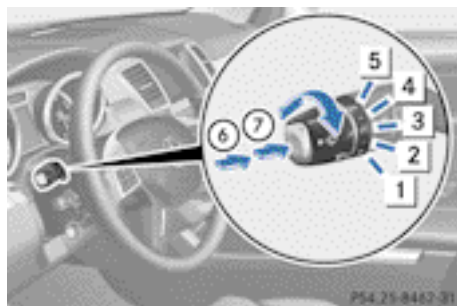

- ❗ Intermittent wiping with rain sensor: due to optical influences and the windscreen becoming dirty in dry weather conditions, the windscreen wipers may be activated inadvertently. This could damage the windscreen wiper blades or scratch the windscreen.

For this reason, you should always switch off the windscreen wipers in dry weather.







Combination switch

- ① 0 Windscreen wipers off
- ② ... Intermittent wipe, low (rain sensor set to low sensitivity)
- ③ Intermittent wipe, high (rain sensor set to high sensitivity)
- ④ — Continuous wipe, slow

- 5  Continuous wipe, fast
- 6  Single wipe
- 7  To wipe with washer fluid



- ▶ Turn the key to position **1** or **2** in the ignition lock (▷ page 159).
- ▶ Turn the combination switch to the corresponding position.

In the  or  position, the appropriate wiping frequency is set automatically according to the intensity of the rain. In the  position, the rain sensor is more sensitive than in the  position, causing the windscreen wipers to wipe more frequently.

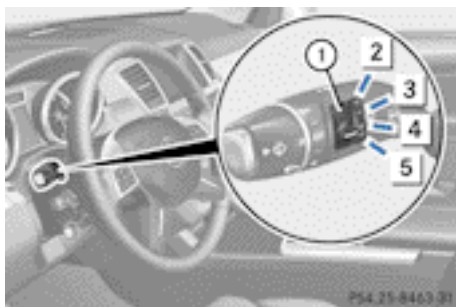
Switching the rear window wiper on/off



Combination switch

- ①  Rear window wiper switch
- 2  To wipe with washer fluid
- 3 **I** To switch on intermittent wiping
- 4 **0** To switch off intermittent wiping
- 5  To wipe with washer fluid

- ▶ Turn the key to position **1** or **2** in the ignition lock (▷ page 159).
- ▶ Turn switch ① on the combination switch to the corresponding position. When the rear window wiper is switched on, the icon appears in the instrument cluster.

Replacing the wiper blades

Important safety notes

WARNING

The wiper arms could start moving and cause an injury if you leave the windscreen wipers switched on.

Remove the key from the ignition lock before replacing the wiper blades.

- !** Never open the bonnet if a windscreen wiper arm has been folded away from the windscreen.

Never fold a windscreen wiper arm without a wiper blade back onto the windscreen/rear window.

Hold the windscreen wiper arm firmly when you change the wiper blade. If you release the windscreen wiper arm without a wiper blade and it falls onto the windscreen, the windscreen may be damaged by the force of the impact.

Mercedes-Benz recommends that you have the wiper blades changed at a qualified specialist workshop.

- !** To avoid damaging the windscreen wiper blades, make sure that you touch only the wiper arm of the windscreen wiper.

Replacing the windscreen wiper blades

Removing the wiper blades

- ▶ Remove the key from the ignition lock.
- ▶ Fold the wiper arm away from the windscreen.

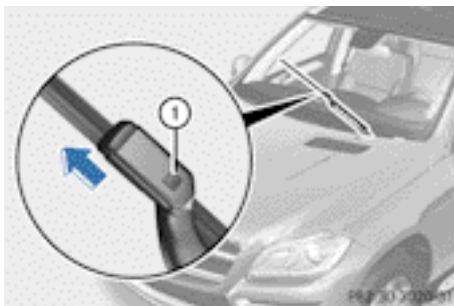

- ▶ Firmly press release knob ① and pull the wiper blade upwards from the wiper arm in the direction of the arrow.

Fitting the wiper blades

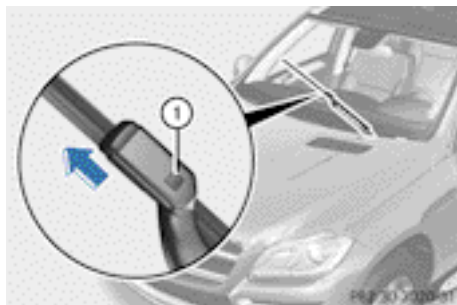

- ▶ Position the new wiper blade in the retainer on the wiper arm and slide it into place in the opposite direction to the arrow. The wiper blade audibly engages.
- ▶ Make sure that wiper blade is seated correctly.
- ▶ Fold the wiper arm back onto the windscreen.

Replacing the rear window wiper blade

Removing the wiper blades

WARNING

The wiper arm could be set in motion and injure you if the windscreen wipers are switched on.

Remove the key from the ignition lock before replacing the wiper blade.

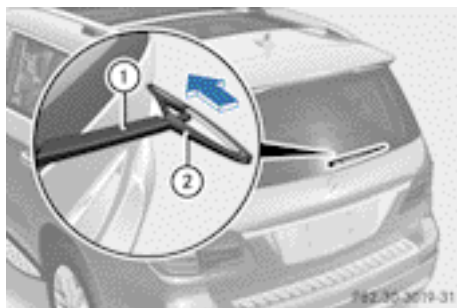

- ▶ Remove the key from the ignition lock.
- ▶ Fold wiper arm ① away from the rear window until it engages.
- ▶ Position wiper blade ② at a right angle to wiper arm ①.
- ▶ Hold wiper arm ① and press wiper blade ② in the direction of the arrow until it releases.
- ▶ Remove wiper blade ②.

Fitting the wiper blade

- ▶ Place new wiper blade ② onto wiper arm ①.
- ▶ Hold wiper arm ① and press wiper blade ② in the opposite direction to the arrow until it engages.
- ▶ Make sure that wiper blade ② is seated correctly.
- ▶ Position wiper blade ② parallel to wiper arm ①.
- ▶ Fold wiper arm ① back onto the rear window.

Problems with the windscreen wipers

The windscreen wipers are obstructed

- ▶ For safety reasons, you should remove the key from the ignition lock.
- or
- ▶ Switch off the engine using the Start/Stop button and open the driver's door.
- ▶ Remove the cause of the obstruction.
- ▶ Switch the windscreen wipers back on.

The windscreen wipers are inoperative

The windscreen wiper drive is malfunctioning.

- ▶ Select another wiper speed on the combination switch.
- ▶ Have the windscreen wipers checked at a qualified specialist workshop.

Useful information	136
Overview of climate control systems	136
Operating the climate control system	141
Adjusting the air vents	154

Useful information

- i** This Owner's Manual describes all models, series and optional equipment for your vehicle that were available at the time of going to press. National variations are possible. Note that your vehicle may not be equipped with all of the functions described. This is also the case for systems and functions relevant to safety.
- i** Read the information on qualified specialist workshops: (▷ page 25).

interval for replacing the filter, which is specified in the Service Booklet. As it depends on environmental conditions, e.g. heavy air pollution, the interval may be shorter than stated in the Service Booklet.

Overview of climate control systems

Important safety notes

WARNING

Observe the settings recommended on the following pages. The windows could otherwise mist up. This may prevent you from observing the traffic conditions, thereby causing an accident.

Climate control regulates the temperature and the humidity in the vehicle interior and filters undesirable substances out of the air. Climate control is only operational when the engine is running. The system only works optimally if the side windows and the roof are closed.

The residual heat function can only be activated or deactivated with the ignition switched off (▷ page 147).

- i** Ventilate the vehicle for a brief period during warm weather, e.g. using the convenience opening feature (▷ page 90). This will speed up the cooling process and the desired vehicle interior temperature will be reached more quickly.
- i** The integrated filter can filter out most particles of dust and completely filters out pollen. A clogged filter reduces the amount of air supplied to the vehicle interior. For this reason, you should always observe the

Control panel for THERMATIC automatic climate control (2-zone)

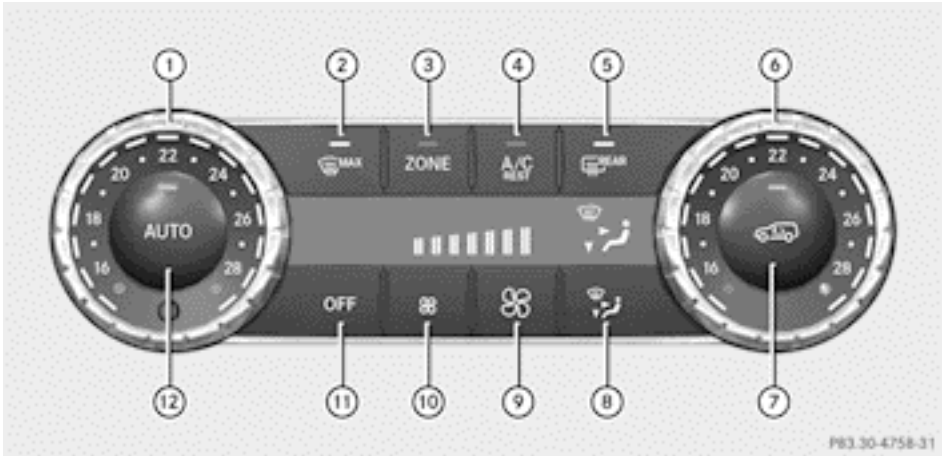

- ① Sets the temperature, left (▷ page 143)
- ② Demists the windscreen (▷ page 145)
- ③ Switches the ZONE function on/off (▷ page 145)
- ④ Activates/deactivates cooling with air dehumidification (▷ page 141) or activates/deactivates the residual heating function (▷ page 147)
- ⑤ Switches the rear window heating on/off (▷ page 146)
- ⑥ Sets the temperature, right (▷ page 143)
- ⑦ Activates/deactivates air-recirculation mode (▷ page 146)
- ⑧ Sets the air distribution (▷ page 144)
- ⑨ Increases the airflow (▷ page 144)
- ⑩ Reduces the airflow (▷ page 144)
- ⑪ Switches climate control on/off (▷ page 141)
- ⑫ Sets climate control to automatic mode (▷ page 142)

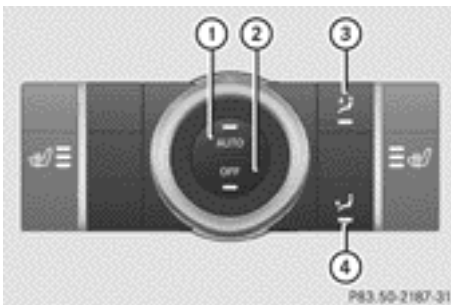



Rear-compartment control panel only in combination with special equipment seat heating

- ① Controls the rear-compartment climate control automatically
- ② Switches rear-compartment climate control on/off

- ③ Directs the airflow through the rear air vents
- ④ Directs the airflow through the footwell vents

Information about using THERMATIC automatic climate control

The following contains notes and recommendations on optimum use of THERMATIC automatic climate control.

- Activate climate control using the **AUTO** and  buttons. The indicator lamps in the **AUTO** and  buttons light up.
- Set the temperature to 22 °C.
- Only use the demisting function briefly until the windscreen is clear again.
- Only use the air-recirculation mode briefly, e.g. if there are unpleasant outside odours or when in a tunnel. The windows could otherwise mist up as no fresh air is drawn into the vehicle in air-recirculation mode.
- Use the ZONE function to adopt the temperature settings on the driver's side for the front-passenger side as well. The indicator lamp above the  button goes out.

Control panel for THERMOTRONIC automatic climate control (3-zone)

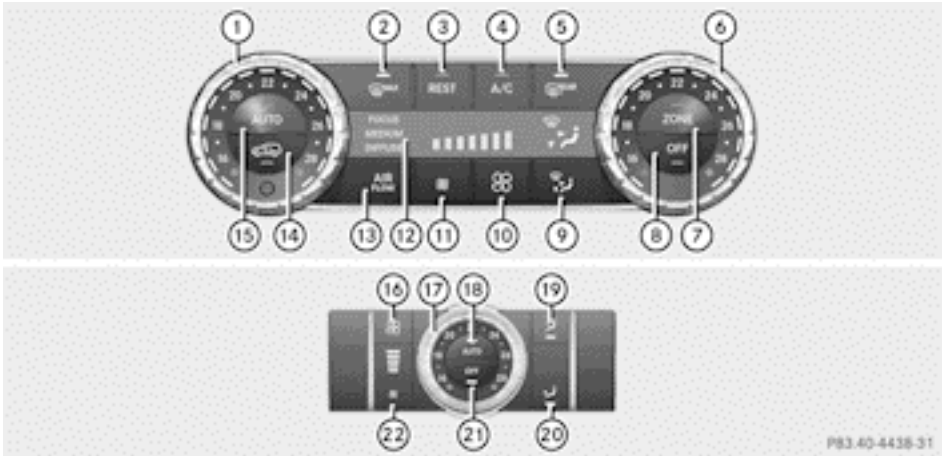

Front control panel

- ① Sets the temperature, left (▷ page 143)
- ② Demists the windscreen (▷ page 145)
- ③ Activates/deactivates the residual heat function (▷ page 147)
- ④ Switches cooling with air dehumidification on/off (▷ page 141)
- ⑤ Switches the rear window heating on/off (▷ page 146)
- ⑥ Sets the temperature, right (▷ page 143)
- ⑦ Switches the ZONE function on/off (▷ page 145)
- ⑧ Switches climate control on/off (▷ page 141)
- ⑨ Sets the air distribution (▷ page 144)
- ⑩ Increases the airflow (▷ page 144)
- ⑪ Reduces the airflow (▷ page 144)
- ⑫ Display
- ⑬ Sets the climate mode (▷ page 143)
- ⑭ Activates/deactivates air-recirculation mode (▷ page 146)
- ⑮ Sets climate control to automatic mode (▷ page 142)

Rear control panel

- ⑯ Increases the airflow (▷ page 144)
- ⑰ Sets the temperature (▷ page 143)
- ⑱ Controls the rear-compartment climate control automatically (▷ page 142)
- ⑲ Directs the airflow through the rear air vents (▷ page 144)
- ⑳ Directs the airflow through the footwell vents (▷ page 144)
- ㉑ Switches rear-compartment climate control on/off (▷ page 141)
- ㉒ Reduces the airflow (▷ page 144)

Control panel for THERMOTRONIC automatic climate control with additional rear-compartment climate control (3-zone)



Front control panel

- ① Sets the temperature, left (▷ page 143)
- ② Demists the windscreen (▷ page 145)
- ③ Switches the ZONE function on/off (▷ page 145)
- ④ Activates/deactivates cooling with air dehumidification (▷ page 141) or activates/deactivates the residual heating function (▷ page 147)
- ⑤ Switches the rear window heating on/off (▷ page 146)
- ⑥ Sets the temperature, right (▷ page 143)
- ⑦ Switches rear-compartment climate control on/off
- ⑧ Switches the climate control on/off (▷ page 141)
- ⑨ Sets the air distribution (▷ page 144)
- ⑩ Increases the airflow (▷ page 144)
- ⑪ Reduces the airflow (▷ page 144)
- ⑫ Display
- ⑬ Sets the climate mode (▷ page 143)
- ⑭ Activates/deactivates air-recirculation mode (▷ page 146)
- ⑮ Climate control, automatic mode (▷ page 142)

Rear control panel

- ⑯ Increases the airflow (▷ page 144)
- ⑰ Sets the temperature (▷ page 143)
- ⑱ Controls the rear-compartment climate control automatically (▷ page 142)
- ⑲ Directs the airflow through the rear air vents (▷ page 144)
- ⑳ Directs the airflow through the footwell vents (▷ page 144)

- ⑰ Switches rear-compartment climate control on/off (▷ page 141)
- ⑱ Reduces the airflow (▷ page 144)

Information about using THERMOTRONIC automatic climate control

The following contains instructions and recommendations to enable you to get the most out of your THERMOTRONIC automatic climate control.

- Activate climate control using the **AUTO** and **A/C** buttons. The indicator lamps above the **AUTO** and **A/C** buttons light up.
- In automatic mode, you can also use the **AIR FLOW** button to set a climate mode (FOCUS/MEDIUM/DIFFUSE). The MEDIUM level is recommended.
- Set the temperature to 22 °C.
- Only use the demisting function briefly until the windscreen is clear again.
- Only use the air-recirculation mode briefly, e.g. if there are unpleasant outside odours or when in a tunnel. The windows could otherwise mist up as no fresh air is drawn into the vehicle in air-recirculation mode.
- Use the ZONE function to adopt the temperature settings on the driver's side for the front-passenger side and the rear compartment as well. The indicator lamp above the **ZONE** button goes out.
- Use the residual heat function if you want to heat or ventilate the vehicle interior when the ignition is switched off. The residual heat function can only be activated or deactivated with the ignition switched off.

Operating the climate control system

Switching climate control on/off

Points to observe before use

- ❗ If climate control is switched off, the air supply and air circulation are also switched

off. Only select this setting briefly. Otherwise, the windows may mist up.

- ❗ Switch on climate control primarily using the **AUTO** button (▷ page 142).

In the rear compartment, you can also switch climate control on and off using the **AUTO** and **OFF** buttons.

Switching on/off

- ▶ Turn the key to position **2** in the ignition lock.
- ▶ **To switch on:** press button **AUTO**.
The indicator lamp in the **AUTO** button lights up. Airflow and air distribution are set to automatic mode.
- or
- ▶ Press the **OFF** button.
The indicator lamp in the **OFF** button goes out. The previous settings are reactivated.
- ▶ **To switch off:** press the **OFF** button.
The indicator lamp in the **OFF** button lights up.

Activating/deactivating the cooling with air dehumidification function

Points to observe before use

⚠ WARNING

If the "cooling with air dehumidification" function is deactivated, the air inside the vehicle will not be cooled (during warm weather) or dehumidified. The windows could mist up more quickly. This may prevent you from observing the traffic conditions, thereby causing an accident.

The cooling with air dehumidification function is only available when the engine is running. The air inside the vehicle is cooled and dehu-

modified according to the temperature selected.









Condensation may drip from the underside of the vehicle when cooling mode is active. This is normal and not a sign that there is a malfunction.

- i** The cooling with air dehumidification function uses refrigerant R134a. This refrigerant does not contain chlorofluorocarbons, and therefore does not damage the ozone layer.

Switching on/off



 button (example)

- ▶ **To activate:** press the  /  button. The indicator lamp in the  /  button lights up.
- ▶ **To deactivate:** press the  /  button. The indicator lamp in the  /  button goes out. The cooling with air dehumidification function has a delayed switch-off feature.

Problems with the cooling with air dehumidification function

When you press the  button, the indicator lamp in the button flashes three times or remains off. You can no longer switch on the cooling with air dehumidification function.

- ▶ Visit a qualified specialist workshop.

Setting climate control to automatic mode

Points to observe before use







In automatic mode, the set temperature is maintained automatically at a constant level. The system automatically regulates the temperature of the dispensed air, the airflow and the air distribution.

Automatic mode will achieve optimal operation if cooling with air dehumidification is also activated. If desired, cooling with air dehumidification can be deactivated.

In the rear compartment, you can also switch climate control for the rear seats to automatic mode using the  button.

Switching on/off



- ▶ Turn the key to position **2** in the ignition lock.
 - ▶ Set the desired temperature.
 - ▶ **To activate:** press the  button. The indicator lamp in the  button lights up. Automatic air distribution and airflow are activated.
 - i** THERMOTRONIC automatic climate control: when automatic mode is activated, you can select a climate mode (▷ page 143).
 - ▶ **To select manually:** press the  button.
- or
- ▶ Press the  or  button. The indicator lamp in the  button goes out.

Setting the climate mode

In automatic mode you can select the following climate modes:

- FOCUS** high airflow that is set slightly cooler
- MEDIUM** medium airflow, standard setting
- DIFFUSE** low airflow that is set slightly warmer and with less of a draught

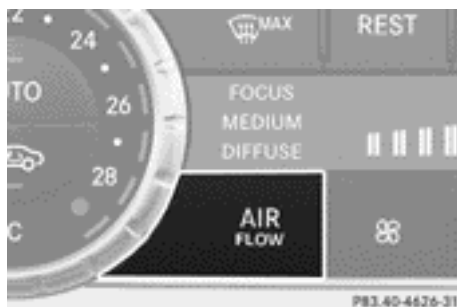

 button (example)

- ▶ Turn the key to position **2** in the ignition lock.
- ▶ Press the **AUTO** button.
- ▶ Press the  button repeatedly until the desired climate mode appears in the display.

Setting the temperature

THERMATIC automatic climate control



Different temperatures can be set for the driver's and front-passenger sides.

- ▶ Turn the key to position **2** in the ignition lock.
- ▶ **To increase/reduce:** turn control ① or ⑥ clockwise or anti-clockwise (▷ page 137).
Only change the temperature setting in small increments. Start at 22 °C.

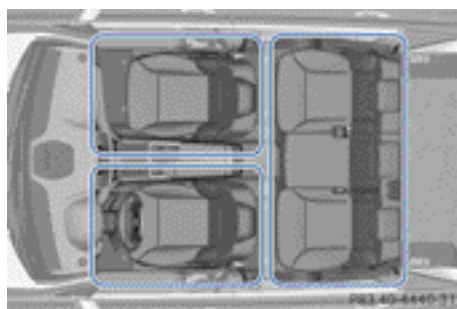
THERMOTRONIC automatic climate control









THERMOTRONIC automatic climate control zones
You can select different temperature settings for the driver's and front-passenger sides as well as for the rear compartment.

- ▶ Turn the key to position **2** in the ignition lock.
- ▶ **To increase/reduce the temperature in the front:** turn controls ① and ⑥ clockwise or anti-clockwise (▷ page 139).
Only change the temperature setting in small increments. Start at 22 °C.
- ▶ **To increase/reduce the temperature in the rear compartment using the front control panel:** press the  button. The indicator lamp in the  button goes out.
- ▶ Turn control ① clockwise or anti-clockwise (▷ page 139).
Only change the temperature setting in small increments. Start at 22 °C.
The temperature setting for the driver's side is adopted for the rear compartment and the front-passenger side.
- ▶ **To increase/decrease the rear compartment temperature using the rear control panel:** turn control ⑰ clockwise or anti-clockwise on the rear control panel (▷ page 139).
Only change the temperature setting in small increments. Start at 22 °C.



Setting the air distribution

Air distribution settings

Front control panel

-  Directs the airflow through the centre vents
-  Directs the airflow through the footwell air vents
-  Directs the airflow through the centre and footwell vents
-  Directs the airflow through the demister vents
-  Directs the airflow through the demister and centre vents.
-  Directs the airflow through the footwell and demister vents
-  Directs the airflow through the demister, centre and footwell air vents.

Rear control panel

-  Directs the airflow through the centre and side air vents in the rear
-  Directs the airflow through the footwell air vents

- i** Using the rear control panel, you can also activate both air distribution positions simultaneously. In order to do this, press both air distribution buttons. The air is then routed through all rear air vents.
- i** Regardless of the air distribution setting, airflow is always directed through the side air vents. The side air vents can only be closed when the controls on the side air vents are turned downwards.



Adjusting



- ▶ Turn the key to position **2** in the ignition lock.
- ▶ Press the  button repeatedly until the desired symbol appears in the display.





Setting the airflow



- ▶ Turn the key to position **2** in the ignition lock.
- ▶ **To increase:** press the  button.
- ▶ **To reduce:** press the  button.
- i** You can use THERMOTRONIC automatic climate control to set the airflow in the rear compartment separately.

Switching the ZONE function on/off





- ▶ **To switch on:** press the  button.
The indicator lamp above the  button lights up.
THERMATIC automatic climate control: the temperature setting for the driver's side is not adopted for the front-passenger side.
THERMOTRONIC automatic climate control: the temperature setting for the driver's side is not adopted for the front-passenger side and the rear compartment.
- ▶ **To switch off:** press the  button.
The indicator lamp above the  button goes out.
THERMATIC automatic climate control: the temperature setting for the driver's side is adopted for the front-passenger side.
THERMOTRONIC automatic climate control: the temperature setting for the driver's side is adopted for the front-passenger side and the rear compartment.

Demisting the windscreen



You can use this function to demist the windscreen or to demist the inside of the windscreen and the side windows.

Switch off the "demisting" function as soon as the windscreen is clear again.



- ▶ Turn the key to position **2** in the ignition lock.
- ▶ **To activate:** press the  button.
The indicator lamp in the  button lights up.

The climate control system switches to the following functions:

- high airflow
- high temperature
- air distribution to the windscreen and front side windows
- air-recirculation mode off

- ▶ **To deactivate:** press the  button.
The indicator lamp in the  button goes out. The previous settings are reactivated. Air-recirculation mode remains deactivated.

or

- ▶ Press the  button.
The indicator lamp in the  button goes out. Airflow and air distribution are set to automatic mode.

or



- ▶ Turn controls ① or ⑥ clockwise or anti-clockwise (▷ page 137) (THERMATIC automatic climate control), (▷ page 139) (THERMOTRONIC automatic climate control).

or



- ▶ Press the  or  button.

Demisting the windows

Windows misted up on the inside

- ▶ Activate the  /  cooling with air dehumidification function.
- ▶ Activate automatic mode .
- ▶ If the windows continue to mist up, activate the demisting function (▷ page 145).
- ▶ **i** You should only select this setting until the windscreen is clear again.

Windows misted up on the outside

► Press the  button repeatedly until the  or  symbol appears in the display.

i You should only select this setting until the windscreen is clear again.

Rear window heating

Switching on/off



WARNING

Clear all windows of ice or snow before setting off. Otherwise, impaired visibility could endanger you and others.



The rear window heating has a high current draw. You should therefore switch it off as soon as the window is clear. It otherwise switches off automatically after several minutes.

If the battery voltage is too low, the rear window heating may switch off.

- Turn the key to position **2** in the ignition lock.
- Press the  button.
The indicator lamp in the  button lights up or goes out.

Problems with the rear window heating

The rear window heating has switched off prematurely or cannot be activated.

- Switch off any consumers that are not required, e.g. reading lamps or interior lighting.
When the battery is sufficiently charged, the rear window heating is activated again automatically.

Activating/deactivating air-recirculation mode



WARNING

Only switch over to air-recirculation mode briefly at low outside temperatures. Otherwise, the windows could mist up, thus impairing visibility and endangering yourself and others. This may prevent you from observing the traffic conditions, thereby causing an accident.



You can deactivate the flow of fresh air if unpleasant odours are entering the vehicle from outside. The air already inside the vehicle will then be recirculated.



The operation of air-recirculation mode is the same for all control panels.

- Turn the key to position **2** in the ignition lock.
- **To activate:** press the  button.
The indicator lamp in the  button lights up.

i In the event of high pollution levels (THERMOTRONIC automatic climate control only) or at high outside temperatures, air-recirculation mode is automatically activated. When air-recirculation mode is acti-

vated automatically, the indicator lamp in the  button is not lit.

Outside air is added after approximately 30 minutes.

- ▶ **To deactivate:** press the  button. The indicator lamp in the  button goes out.

- ▶ **i** Air-recirculation mode deactivates automatically:
 - after approximately five minutes at outside temperatures below approximately 5 °C
 - after approximately five minutes if cooling with air dehumidification is deactivated
 - after approximately 30 minutes at outside temperatures above approximately 5 °C with the "cooling with air dehumidification" function switched on.





Convenience opening/closing using the air-recirculation button

WARNING

Make sure that nobody can become trapped between the side window and the door frame as the side windows are opened and closed. Make sure that all objects and body parts are clear of the side windows when they are being opened or closed. You or the objects could be drawn in or become trapped between the side window and the door frame as the window moves. If there is a risk of entrapment, operate the  switch to move the side window in the opposite direction.

Make sure that nobody can become trapped as the sliding sunroof/panorama sliding sunroof is opened and closed. If there is a risk of entrapment, operate the  switch to move the sliding sunroof/panorama sliding sunroof in the opposite direction.



- ▶ **Convenience closing feature:** press and hold the  button until the side windows and the sliding sunroof/panorama sliding sunroof are closed. The indicator lamp in the  button lights up. Air-recirculation mode is activated.
- ▶ **Convenience opening feature:** press and hold the  button until the side windows and the sliding sunroof/panorama sliding sunroof are opened. The side windows and the sliding sunroof/panorama sliding sunroof move back to their original position. The indicator lamp in the  button goes out. Air-recirculation mode is deactivated.



- ▶ **i** If you open the side windows or the sliding sunroof/panorama sliding sunroof manually after closing them with the convenience closing feature, they will remain in this position when opened using the convenience opening feature.

Activating/deactivating the residual heat function





It is possible to make use of the residual heat of the engine to continue heating the stationary vehicle for up to 30 minutes after the engine has been switched off. The heating time depends on the temperature that has been set for the vehicle interior.



► **To activate:** press the  /  button.

The indicator lamp in the  /  button lights up.

i The blower will run at a low speed regardless of the airflow setting.

i If you activate the residual heat function at high temperatures, only the ventilation will be activated. The blower runs at medium speed.

► **To deactivate:** press the  /  button.

The indicator lamp in the  /  button goes out.

Residual heat is deactivated automatically:

- after approximately 30 minutes
- when the ignition is switched on
- if the battery voltage drops
- when the auxiliary heating is activated

Auxiliary heating

Important safety notes

WARNING

Exhaust fumes are produced when the auxiliary heating is in operation. Inhaling these exhaust fumes can be poisonous. You should therefore switch off the auxiliary heating in confined spaces without an extraction system, e.g. a garage.

WARNING

When operating the auxiliary heating parts of the vehicle can get very hot. Make sure that the exhaust system does not under any circumstances come into contact with easily ignitable material such as dry grass or fuels. The material could otherwise ignite and set

the vehicle alight. Choose your parking spot accordingly.

Operating the auxiliary heating is thus prohibited at filling stations or when your vehicle is being refuelled. You must therefore switch off the auxiliary heating at filling stations.

! Operating the auxiliary heating/ventilation draws on the vehicle battery. After you have heated or ventilated the vehicle a maximum of two times, drive for a longer distance.

i Switch the auxiliary heating on regularly once a month for about ten minutes.

The auxiliary heating heats the air in the vehicle interior to the set temperature without using the heat of the running engine. The auxiliary heating is operated directly using the vehicle's fuel. For this reason, the tank content must be at least at reserve fuel level to ensure that the auxiliary heating functions.

The auxiliary heating/ventilation automatically adjusts to changes in temperature and weather conditions. For this reason, the auxiliary heating could switch from ventilation mode to heating mode or from heating mode to ventilation mode.

The auxiliary heating switches off when the engine is switched off. The auxiliary ventilation switches off when you turn the key to key position **2**.

The auxiliary heating switches off automatically after 30 minutes. This time limit can be altered. To do this, visit a qualified specialist workshop.

You cannot use the auxiliary ventilation to cool the vehicle interior to a temperature lower than the outside temperature.

Before switching on

- Turn the key to position **2** in the ignition lock.
- Set the temperature.

The auxiliary heating/ventilation can be activated even when climate control is set to

manual. Optimum comfort can be attained when the system is set to automatic mode. Set the temperature to 22 °C.

The auxiliary heating/ventilation can be activated or deactivated using the remote control or the button on the centre console.

The on-board computer can be used to specify up to three departure times, one of which may be preselected (▷ page 284).

Switching the auxiliary heating/ventilation on/off using the centre console button

The colours of the indicator lamps on the button have the following meanings:

- Blue Auxiliary ventilation switched on
- Red Auxiliary heating switched on
- Yellow Departure time preselected (▷ page 284)



Switch in the centre console

► To switch auxiliary heating/ventilation on: press button ①.

The red or blue indicator lamp in button ① lights up.

► To switch auxiliary heating/ventilation off: press button ①.

The red or blue indicator lamp in button ① goes out.

Switching the auxiliary heating/ventilation on/off using the remote control

Points to observe before use

Your vehicle comes with one remote control. You may use two additional remote controls for your vehicle. For more information, please contact a qualified specialist workshop.

The remote control has a maximum range of approximately 300 metres. This range is reduced by:

- sources of radio interference
- solid objects between the remote control and the vehicle
- the remote control being in an unfavourable position in relation to the vehicle
- transmitting from an enclosed space

① The optimum range can be achieved if you hold the remote control vertically, pointing upwards when you press one of the buttons.

① A battery symbol appears in the display when the battery in the remote control is low. Replace the remote control battery (▷ page 151).

Switching the auxiliary heating/ventilation on/off

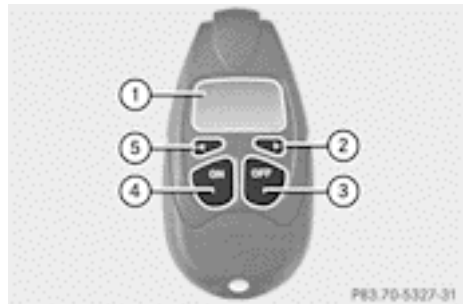

Auxiliary heating remote control

① Display

②  To check the status/set the departure time

③  To switch off the auxiliary heating/ventilation

- ④ **[ON]** To switch on the auxiliary heating/ventilation
- ⑤ **[<]** To check the status/set the departure time

- ▶ **To switch on:** press the **[ON]** button.
ON is shown in the remote control display.
- ▶ **To deactivate:** press the **[OFF]** button.
OFF is shown in the remote control display.

Checking the status of the auxiliary heating/ventilation

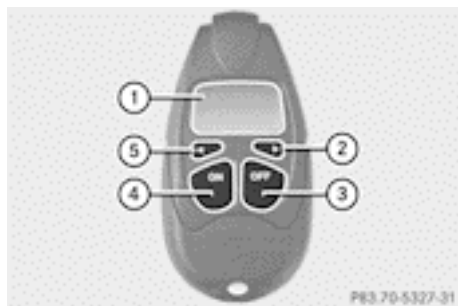

Auxiliary heating remote control

- ① Display
 - ② **[>]** To check the status/set the departure time
 - ③ **[OFF]** To switch off the auxiliary heating/ventilation
 - ④ **[ON]** To switch on the auxiliary heating/ventilation
 - ⑤ **[<]** To check the status/set the departure time
- ▶ Press the **[<]** or **[>]** button.

The following messages may appear in the display:

Display	Meaning
	The auxiliary heating/ventilation is switched off.

	The auxiliary ventilation is switched on. The number in the display shows the remaining time (in minutes) for the auxiliary ventilation.
	The auxiliary heating is switched on. The number in the display shows the remaining time (in minutes) for the auxiliary heating.
	A departure time has been activated. The departure time appears in the display.
	A departure time has been activated. The auxiliary ventilation is currently selected. The departure time appears in the display.
	A departure time has been activated. The auxiliary heating is currently selected. The departure time appears in the display.

Setting the departure time

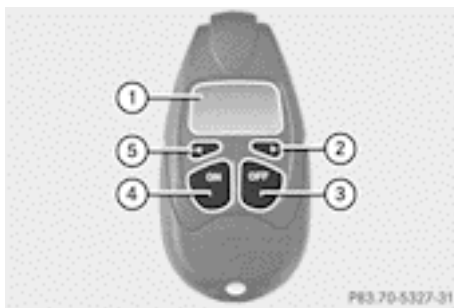

Auxiliary heating remote control

- ① Display
- ② **[>]** To check the status/set the departure time

- ③ **OFF** To switch off the auxiliary heating/ventilation
 - ④ **ON** To switch on the auxiliary heating/ventilation
 - ⑤ **<** To check the status/set the departure time
- ▶ Press the **<** or **>** button repeatedly until the time to be changed appears in the display.
 - ▶ Press the **ON** and **OFF** buttons simultaneously. The  symbol in the remote control display flashes.
 - ▶ Press the **<** or **>** button to set the desired departure time.
- i** The longer you press the **<** or **>** button, the faster the time changes.
- ▶ Press the **ON** and **OFF** buttons simultaneously. The new departure time is stored.

Activating the set departure time

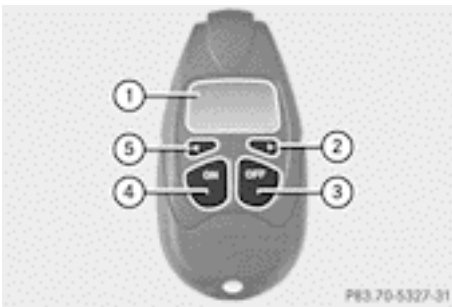

- Auxiliary heating remote control
- ① Display
 - ② **>** To check the status/set the departure time
 - ③ **OFF** To switch off the auxiliary heating/ventilation
 - ④ **ON** To switch on the auxiliary heating/ventilation
 - ⑤ **<** To check the status/set the departure time

- ▶ Press the **<** or **>** button repeatedly until the desired departure time appears in the display.
- ▶ Press the **ON** button. The  symbol and the departure time appear in the display.

Deactivating a set departure time

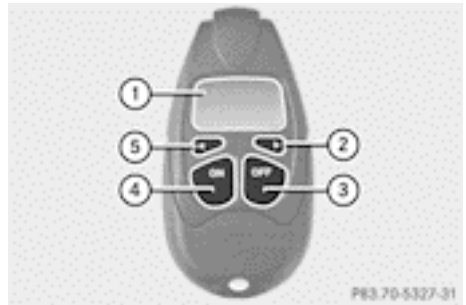

- Auxiliary heating remote control
- ① Display
 - ② **>** To check the status/set the departure time
 - ③ **OFF** To switch off the auxiliary heating/ventilation
 - ④ **ON** To switch on the auxiliary heating/ventilation
 - ⑤ **<** To check the status/set the departure time
- ▶ Press the **<** or **>** button. The status of the auxiliary heating is shown in the display.
 - ▶ Press the **>** button. The first departure time stored appears in the display.
 - ▶ Press the **OFF** button. The display message **OFF** appears in the display.

Replacing the remote control battery

⚠ WARNING
 Batteries contain poisonous substances. Swallowing/ingesting batteries can result in serious personal injury or death.

Always keep batteries away from children. If a battery is swallowed, seek immediate medical attention.

ⓘ Environmental note



Batteries contain pollutants. It is illegal to dispose of them with the household rubbish. They must be collected separately and disposed of in an environmentally responsible recycling system.



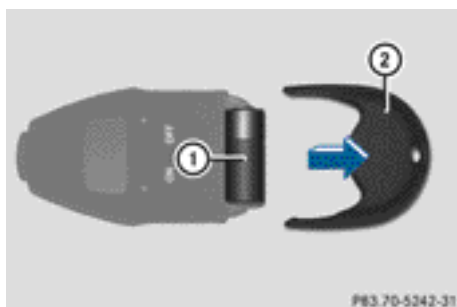

Dispose of batteries in an environmentally responsible manner. Take discharged batteries to a qualified specialist workshop or to a collection point for used batteries.



One 6 V pin battery, type 2CR11108 is required.

- ▶ Prise apart the side arms of battery cover ② and pull off battery cover ②.
- ▶ Remove old battery ①.
- ▶ Insert the new battery. Observe the polarity signs on the back of the remote control when doing so.
- ▶ Slide battery cover ② back onto the remote control.
- ▶ Use the remote control to check the vehicle's auxiliary heating functions.

Problems with the auxiliary heating/ventilation

Display messages	Possible causes/consequences and ► Solutions
 FAIL	<p>The signal transmission between the transmitter and the vehicle is faulty.</p> <ul style="list-style-type: none"> ► Change your position in relation to the vehicle, moving closer if necessary. ► Make another attempt to switch the auxiliary heating on or off using the remote control.
 FAIL	<p>there is not enough fuel in the fuel tank, or the auxiliary heating is faulty.</p> <ul style="list-style-type: none"> ► Refuel at the nearest filling station. ► Make another attempt to switch on the auxiliary heating using the remote control. ► Have the auxiliary heating checked at a qualified specialist workshop.
FAIL	<p>This display message may appear if you attempt to activate the auxiliary heating or during a status query.</p> <p>If the auxiliary heating does not switch on or has switched off while running, this has occurred due to one of the following reasons:</p> <ul style="list-style-type: none"> • the auxiliary heating was started more than twice when the engine was switched off. • the starter battery is not sufficiently charged. • There is too little fuel in the fuel tank. • the auxiliary heating is faulty. <p>If the auxiliary heating was switched on more than twice:</p> <ul style="list-style-type: none"> ► Switch on the engine and let it run for more than 10 seconds. ► Make another attempt to switch on the auxiliary heating using the remote control. <p>If the starter battery is not sufficiently charged:</p> <ul style="list-style-type: none"> ► Charge the starter battery. ► Make another attempt to switch on the auxiliary heating using the remote control. <p>If there is not enough fuel:</p> <ul style="list-style-type: none"> ► Refuel at the nearest filling station. ► Make another attempt to switch on the auxiliary heating using the remote control.

Display messages

Possible causes/consequences and ► Solutions

If the auxiliary heating is faulty:

- Have the auxiliary heating checked at a qualified specialist workshop.

Adjusting the air vents

Important safety notes

⚠ WARNING

Very hot or very cold air can flow from the air vents. This could cause burns or frostbite to bare skin in the immediate vicinity of the vents. Keep bare skin away from these air outlets. If necessary, direct the airflow away to a different area of the vehicle interior.

In order to ensure the direct flow of fresh air through the air vents into the vehicle interior, please observe the following notes:

- keep the air inlet grille on the bonnet and in the engine compartment on the front-passenger side free of blockages, such as ice, snow or leaves.
 - never cover the vents or ventilation grilles in the vehicle interior.
- i** For virtually draught-free ventilation, adjust the sliders of the air vents to the centre position.

Setting the centre air vents

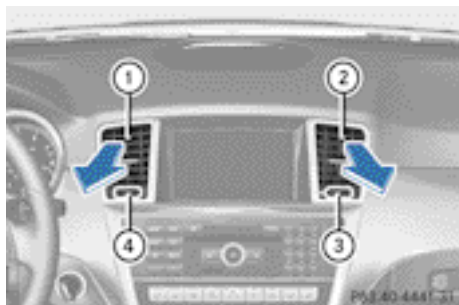

- ① Centre air vent, left
- ② Centre air vent, right

- ③ Centre vent thumbwheel, right

- ④ Centre vent thumbwheel, left

- **To open/close:** turn thumbwheels ③ and ④ to the right or left.

Setting the side air vents

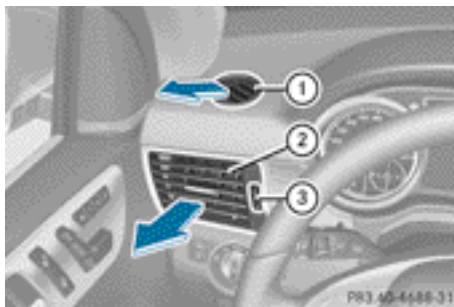

- **To open/close:** turn thumbwheel ③ up or down.

- i** Side window demister vent ① is never completely shut, even if side air vent ② is shut.

Setting the glove compartment air vent

- !** Close the air vent when heating the vehicle.

At high outside temperatures, open the air vent and activate the "cooling with air dehumidification" function. Otherwise, temperature-sensitive items stored in the glove compartment could be damaged.

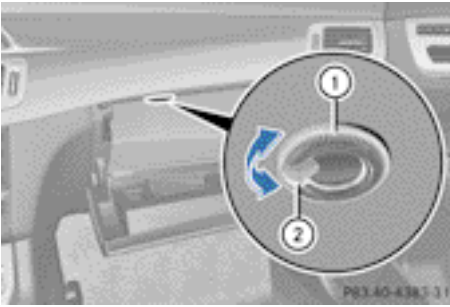

- ① Air vent thumbwheel
- ② Air vent

When automatic climate control is activated, the glove compartment can be ventilated, for instance to cool its contents. The level of airflow depends on the airflow and air distribution settings.

- **To open/close:** turn thumbwheel ① clockwise or anti-clockwise.

Setting the rear-compartment air vents

Setting the centre vents in the rear compartment

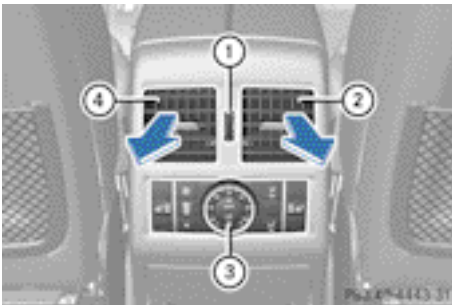

Centre vents with rear control panel (example)

- ① Rear-compartment air vent thumbwheel
- ② Rear-compartment air vent, right
- ③ Rear control panel
- ④ Rear-compartment air vent, left

- **To open/close:** turn thumbwheel ① up or down.

Setting the rear-compartment side air vents

2nd row of seats

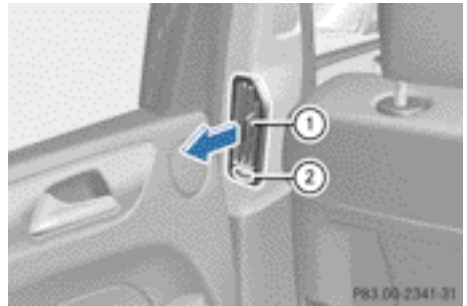

- ① Rear-compartment side air vent
- ② Thumbwheel for rear-compartment side air vent

- **To open/close:** turn thumbwheel ② to the left or right.

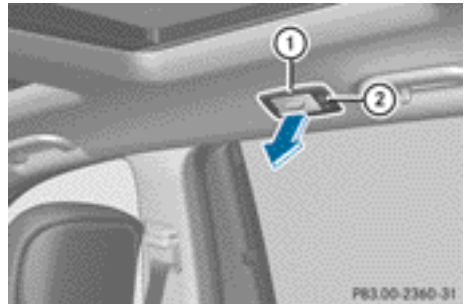

Rear-compartment side air vent in the roof lining

- ① Rear-compartment side air vent
- ② Thumbwheel for rear-compartment side air vent

- **To open/close:** turn thumbwheel ② up or down.

Third row of seats

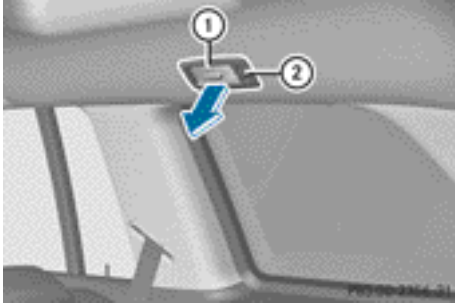

Rear-compartment side air vent in the roof lining

- ① Rear-compartment side air vent
- ② Thumbwheel for rear-compartment side air vent

► **To open/close:** turn thumbwheel ② up or down.

Useful information	158
Running-in notes	158
Driving	158
Automatic transmission	167
Refuelling	174
Parking	181
Driving tips	184
Driving systems	193
Towing a trailer	257

Useful information

- i** This Owner's Manual describes all models, series and optional equipment for your vehicle that were available at the time of going to press. National variations are possible. Note that your vehicle may not be equipped with all of the functions described. This is also the case for systems and functions relevant to safety.
- i** Read the information on qualified specialist workshops: (▷ page 25).

Running-in notes

Important safety notes

New brake pads/brake pads and discs that have been replaced only achieve optimum braking effect after several hundred kilometres of driving. Compensate for the reduced braking effect by applying greater force to the brake pedal.

The first 1,500 km

If you treat the engine with sufficient care from the very start, you will be rewarded with excellent performance for the remainder of the engine's life.

- Drive at varying vehicle speeds and engine speeds for the first 1,500 km.
- Avoid overstraining the vehicle during this period, e.g. driving at full throttle.
- Change gear in good time, before the rev counter needle is $\frac{2}{3}$ of the way to the red area of the rev counter.
- Do not shift down a gear manually in order to brake.
- Try to avoid depressing the accelerator pedal beyond the point of resistance (kick-down).
- Shift ranges **3**, **2** or **1** should only be engaged when driving slowly, e.g. when driving in mountainous terrain.

After 1,500 km, you may gradually accelerate the vehicle to full road and engine speeds.

Additional running-in notes for AMG vehicles:

- do not drive at speeds above 140 km/h for the first 1,500 km.
 - only allow the engine to reach a maximum engine speed of 4,500 rpm briefly.
 - drive the vehicle mainly in drive program **C** for the first 1,500 km.
- i** You should also observe these notes on running in if the engine or parts of the drive train on your vehicle have been replaced.

Driving

Important safety notes

WARNING

Objects in the driver's footwell can restrict the pedal travel or obstruct a depressed pedal. The operating and road safety of the vehicle is jeopardised. There is a risk of an accident. Make sure that all objects in the vehicle are stowed correctly, and that they cannot enter the driver's footwell. Fit the floor mats securely and as specified in order to ensure sufficient clearance for the pedals. Do not use loose floor mats.

WARNING

Unsuitable footwear can hinder correct usage of the pedals, e.g.:

- shoes with thick soles
- shoes with high heels
- slippers

There is a risk of an accident.

Wear suitable footwear to ensure correct usage of the pedals.

WARNING

If you switch off the ignition while driving, safety-relevant functions are only available with limitations, or not at all. This could affect, for example, the power steering and the brake

boosting effect. You will require considerably more effort to steer and brake. There is a risk of an accident.

Do not switch off the ignition while driving.

WARNING

If the parking brake has not been fully released when driving, the parking brake can:

- overheat and cause a fire
- lose its hold function.

There is a risk of fire and an accident. Release the parking brake fully before driving off.

! Warm up the engine quickly. Do not use the engine's full performance until it has reached operating temperature.

Only set the automatic transmission to the respective drive positions when the vehicle is stationary.

Where possible, avoid spinning the drive wheels when pulling away on slippery roads. Otherwise, you could damage the drive train.

! **AMG vehicles:** at low engine oil temperatures (below +20 °C), the maximum engine speed is restricted in order to protect the engine. To protect the engine and maintain smooth engine operation, avoid driving at full throttle when the engine is cold.

Key positions

Key

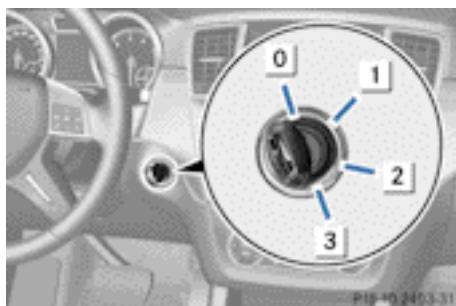

- 0** To remove the key
- 1** Power supply for some consumers, such as the windscreen wipers
- 2** Ignition (power supply for all consumers) and drive position
- 3** To start the engine

i If the key does not belong to the vehicle, it can still be turned in the ignition lock. However, the ignition will not be switched on. The engine cannot be started.

KEYLESS-GO

General notes

- Do not keep the KEYLESS-GO key together with:
 - electronic devices, e.g. a mobile phone or another key
 - metallic objects, e.g. coins or metal film
 - metallic objects, e.g. a metal case
 This can affect the function of the key with KEYLESS-GO.

Do not keep the KEYLESS-GO key in the temperature-controlled cup holder (> page 347). Otherwise, the KEYLESS-GO key will not be detected.

Vehicles with KEYLESS-GO are equipped with a key featuring an integrated KEYLESS-GO function and a detachable Start/Stop button.

The Start/Stop button must be inserted in the ignition lock and the key with the integrated KEYLESS-GO function must be in the vehicle. Pressing the Start/Stop button several times in succession corresponds to the different key positions in the ignition lock. This is only the case if you are not depressing the brake pedal.

If you depress the brake pedal and press the Start/Stop button, the engine starts immediately.

- i** The engine can be switched off while the vehicle is in motion by pressing and holding the Start/Stop button for three seconds. This function operates independently of the ECO start/stop automatic engine switch-off function.

Key positions with KEYLESS-GO

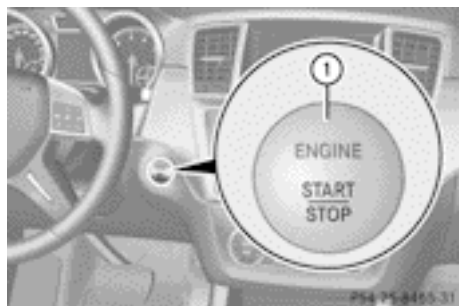

Switching on the power supply

- ▶ If Start/Stop button ① has not yet been pressed, this corresponds to the key being removed from the ignition.
- ▶ Press Start/Stop button ① once. The power supply is switched on. You can now activate the windscreen wipers, for example.
- i** The power supply is switched off again if:
 - the driver's door is opened and
 - you press Start/Stop button ① twice when in this position

Switching on the ignition

- ▶ Press Start/Stop button ① twice. The ignition is switched on.
- i** The power supply is switched off again if:
 - the driver's door is opened and
 - you press Start/Stop button ① once when in this position

Removing the Start/Stop button

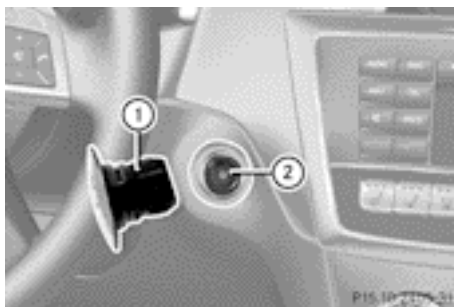

You can remove the Start/Stop button from the ignition lock and start the vehicle as normal using the key.

- ▶ Remove Start/Stop button ① from ignition lock ②.
- i** You do not have to remove the Start/Stop button from the ignition lock when you leave the vehicle.
- i** It is only possible to switch between KEYLESS-GO mode and key operation when the transmission is in position **P**.
- i** When you insert Start/Stop button ① into ignition lock ②, the system needs approximately two seconds' recognition time. You can then use Start/Stop button ①.

Starting the engine

Important safety notes

WARNING



Combustion engines emit poisonous exhaust gases such as carbon monoxide. Inhaling these exhaust gases leads to poisoning. There is a risk of fatal injury. Therefore never leave the engine running in enclosed spaces without sufficient ventilation.

- i Vehicles with a petrol engine:** the catalytic converter is preheated for up to 30seconds after a cold start. The sound of the engine may change during this time.

Automatic transmission

- ▶ Shift the transmission to position **P** (▷ page 168).
The transmission position display in the multifunction display shows **P** (▷ page 168).
- i** You can also start the engine when the transmission is in position **N**.

Starting procedure with the key

- ▶ **To start a petrol engine:** turn the key to position **3** in the ignition lock (▷ page 159) and release it as soon as the engine is running.
- ▶ **To start a diesel engine:** turn the key to position **2** in the ignition lock (▷ page 159).
The  preglow indicator lamp in the instrument cluster lights up.
- ▶ When the  preglow indicator lamp goes out, turn the key to position **3** (▷ page 159) and release it as soon as the engine is running.
- i** You can start the engine without preglow if the engine is warm.

Using KEYLESS-GO to start the engine

WARNING

Your vehicle can be started using a valid KEYLESS-GO key. For this reason, children should never be left unsupervised in the vehicle. Always take the key with you when leaving the vehicle, even if you are only leaving it for a short time.

- ▶ Depress the brake pedal and keep it depressed.
- ▶ **To start a petrol engine:** press the Start/Stop button (▷ page 159) once.
The engine starts.
- ▶ **To start a diesel engine:** press the Start/Stop button (▷ page 159) once.
Preglow is activated and the engine starts.

- i** The Start/Stop button can be used to start the vehicle without inserting the key into the ignition lock. The key must be in the vehicle and the Start/Stop button must be inserted in the ignition lock. This mode for starting the engine operates independently of the ECO start/stop automatic engine start function.

Pulling away

Automatic transmission

WARNING

If the engine speed is above the idling speed and you engage transmission position **D** or **R**, the vehicle could pull away suddenly. There is a risk of an accident.

When engaging transmission position **D** or **R**, always firmly depress the brake pedal and do not simultaneously accelerate.

- ▶ Depress the brake pedal and keep it depressed.
- ▶ Shift the transmission to position **D** or **R** (▷ page 167).

- ▶ Release the brake pedal.
- ▶ Carefully depress the accelerator pedal.

The electric parking brake (▷ page 182) is automatically released.

The red  indicator lamp in the instrument cluster goes out.

i It is only possible to shift the transmission from position **P** to the desired position if you depress the brake pedal. Only then is the parking lock released. If the brake pedal is not depressed, the DIRECT SELECT lever can still be moved but the parking lock remains engaged.

i The vehicle locks centrally once you have pulled away. The locking knobs in the doors drop down.

You can open the doors from the inside at any time.

You can also deactivate the automatic locking feature (▷ page 283).

i Upshifts take place at higher engine speeds after a cold start. This helps the catalytic converter to reach its operating temperature more quickly.

Pulling away with a trailer



To ensure that you do not roll backwards when pulling away on an uphill slope, engage the electric parking brake.

- ▶ Press and hold handle .
- The electric parking brake continues to brake and prevent the vehicle from rolling backwards.

The red  indicator lamp in the instrument cluster remains on.

- ▶ Depress the accelerator pedal.
- ▶ As soon as the vehicle/trailer combination is held by the driving force of the engine, release lever .

The electric parking brake is released.

The red  indicator lamp in the instrument cluster goes out.

Hill start assist

WARNING

After a short time, hill start assist will no longer brake your vehicle and it could roll away. There is a risk of an accident and injury.

Therefore, quickly move your foot from the brake pedal to the accelerator pedal. Never leave the vehicle when it is held by hill start assist.

- ▶ Remove your foot from the brake pedal. The vehicle is then held for about a second.
- ▶ Pull away.

Hill start assist helps you when pulling away forwards or in reverse on an uphill gradient. It holds the vehicle for a short time after you have removed your foot from the brake pedal. This gives you enough time to move your foot from the brake pedal to the accelerator pedal and depress it before the vehicle begins to roll.

Hill start assist will not function if:

- you are pulling away on a level road or a downhill gradient.
- the transmission is in position **N**.
- the electric parking brake is engaged.
- ESP[®] is malfunctioning.

ECO start/stop function

Important safety notes

⚠ WARNING

If the engine is switched off automatically and you exit the vehicle, the engine is restarted automatically. The vehicle may begin moving. There is a risk of accident and injury.

If you wish to exit the vehicle, always turn off the ignition and secure the vehicle against rolling away.

General notes



① ECO start/stop display

The ECO start/stop function switches the engine off automatically if the vehicle stops moving.

When pulling away again, the engine starts automatically. The ECO start/stop function thereby helps you to reduce the fuel consumption and emissions of your vehicle.

Every time you switch on the engine using the key or the Start/Stop button, the ECO start/stop function is activated.

AMG vehicles: the ECO start/stop function is only available in drive program C.

The system is operational when the **ECO** symbol is shown in green in the multifunction display.

AMG vehicles: the AMG menu in the multifunction display additionally shows the **Stop/Start active** message.

If not all conditions for automatic engine switch-off are fulfilled (▷ page 164), the **ECO** symbol is shown in yellow in the multifunction display.

AMG vehicles: the AMG menu in the multifunction display additionally shows the **Stop/Start inactive** message.

If the ECO start/stop function has been manually deactivated (▷ page 163) or if a malfunction has caused the system to be deactivated, the **ECO** symbol is not displayed.

AMG vehicles: the **Stop/Start active** or **Stop/Start inactive** display message goes out in the AMG menu of the multifunction display.

If the engine is switched off and the **ECO** symbol is shown in green in the multifunction display, the engine has been switched off automatically. However, all vehicle systems remain active.

Deactivating/activating the ECO start/stop function

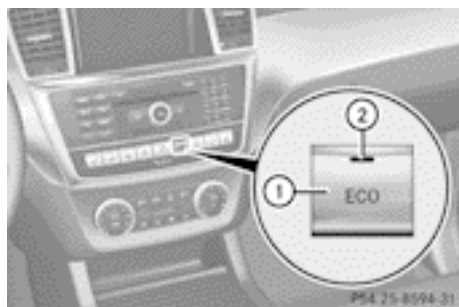

ECO button

► **To switch off (except AMG vehicles):** press button ①. Indicator lamp ② on button ① and the **ECO** symbol in the multifunction display go out.

► **To switch on (except AMG vehicles):** press button ①. Indicator lamp ② lights up. If all conditions for automatic engine switch-off (▷ page 164) are fulfilled, the **ECO** symbol is shown in green in the multifunction display.

If not all conditions for automatic engine switch-off are fulfilled, the

(▷ page 164) **ECO** symbol is shown in yellow in the multifunction display. If this is the case, the ECO start/stop function is not available.

▶ **To switch off (AMG vehicles):** in program **C**, press button ①.

or

▶ Switch to drive program **S** or **M**

(▷ page 170).

Indicator lamp ② on button ① and the **ECO** symbol in the multifunction display go out.

The **Stop/Start active** or **Stop/Start inactive** message in the AMG menu in the multifunction display goes out.

▶ **To switch on (AMG vehicles):** press button ①.

Indicator lamp ② lights up. If drive program **S** or **M** is active, the automatic transmission switches to drive program **C**.

If all conditions for automatic engine switch-off (▷ page 164) are fulfilled, the **ECO** symbol is shown in green in the multifunction display. In addition, the **Stop/Start active** message is shown in the AMG menu in the multifunction display.

If not all conditions for automatic engine switch-off (▷ page 164) are fulfilled, the **ECO** symbol is not shown. If this is the case, the ECO start/stop function is not available. In addition, the **Stop/Start inactive** message is shown in the AMG menu in the multifunction display.

- ❗ If indicator lamp ② is off, the ECO start/stop function has been deactivated manually or as the result of a malfunction. The engine will then not be switched off automatically when the vehicle stops.
- ❗ Every time you switch on the engine using the key or the Start/Stop button, the ECO start/stop function is activated.

Automatic engine switch-off

If the vehicle is braked to a standstill in **D** or **N**, the ECO start/stop function switches off the engine automatically.

The ECO start/stop function is operational and the **ECO** symbol is displayed in green in the multifunction display if:

- the indicator lamp in the ECO button is lit green
- none of the off-road programs are selected
- the vehicle is stationary
- the outside temperature is within the comfort range
- the engine is at normal operating temperature
- the set temperature for the vehicle interior has been reached
- the battery is sufficiently charged
- the system detects that the windscreen is not misted up when the air-conditioning system is switched on
- the bonnet is closed
- the driver's door is closed and the driver's seat belt is fastened

If not all conditions for automatic engine switch-off are fulfilled, the **ECO** symbol is shown in yellow.

AMG vehicles: the AMG menu in the multifunction display additionally shows the **Stop/Start inactive** message.

- ❗ If you shift the transmission from **R** to **D**, the ECO start/stop function is available again once the **ECO** symbol reappears in green in the multifunction display.
- ❗ **All vehicles (except AMG vehicles):** automatic engine switch-off can take place a maximum of four times consecutively (initial stop, then three subsequent stops). The **ECO** symbol is shown in yellow in the multifunction display after the engine has been started automatically for the fourth time. When the **ECO** symbol is shown in green

in the multifunction display, automatic engine switch-off is again possible.

- i** **AMG vehicles:** times which the engine can be automatically switched off.
 - i** You can also activate the HOLD function when the vehicle is stationary if the engine has been switched off automatically. It is then not necessary to continue depressing the brake pedal during the automatic stop phase. When you depress the accelerator pedal, the engine starts automatically and the braking effect of the HOLD function is deactivated. Depress the accelerator pedal gently, as the engine must be started first.
 - i** During automatic engine switch-off, the climate control system only operates at a reduced capacity. If you require full climate control capacity, the ECO start/stop function can be deactivated by pressing the ECO button (▷ page 163).
- the system detects moisture on the wind-screen when the air-conditioning system is switched on
 - the battery's charge status is too low
- i** Shifting the transmission to position **P** does not start the engine.

Automatic engine start

The engine is started automatically if:

- you switch off the ECO start/stop function by pressing the ECO button
- you release the brakes when in transmission position **D** or **N**, when the HOLD function is inactive
- you depress the accelerator pedal
- you engage reverse gear **R**
- you move the transmission out of position **P**
- you switch to drive program **S** or **M** (AMG vehicles)
- you switch to an off-road program (except AMG vehicles)
- you unfasten your seat belt or open the driver's door
- the vehicle starts to roll
- the brake system requires this
- the temperature in the vehicle interior deviates from the set range

Problems with the engine

Problem	Possible causes/consequences and ► Solutions
<p>The engine does not start. The starter motor can be heard.</p>	<ul style="list-style-type: none"> • There is a malfunction in the engine electronics. • There is a malfunction in the fuel supply. <p>► Before attempting to start the engine again, turn the key in the ignition back to position 0 or press the Start/Stop button repeatedly until all indicator lamps in the instrument cluster go out.</p> <p>► Try to start the engine again (▷ page 161). Avoid excessively long and frequent attempts to start the engine, as this will drain the battery.</p> <p>If the engine does not start after several attempts:</p> <p>► Consult a qualified specialist workshop.</p>
<p>The engine does not start. The starter motor can be heard. The reserve fuel warning lamp is lit and the fuel gauge display shows 0.</p>	<p>The fuel tank is empty.</p> <p>► Refuel the vehicle.</p>
<p>The engine does not start. You cannot hear the starter motor.</p>	<p>The on-board voltage is too low because the battery is too weak or discharged.</p> <p>► Jump-start the vehicle (▷ page 386).</p> <p>If the engine does not start despite attempts to jump-start it:</p> <p>► Consult a qualified specialist workshop.</p> <p>The starter motor was exposed to a thermal load that was too high.</p> <p>► Allow the starter motor to cool down for approximately two minutes.</p> <p>► Try to start the engine again.</p> <p>If the engine still does not start:</p> <p>► Consult a qualified specialist workshop.</p>
<p>Vehicles with a petrol engine:</p> <p>The engine is not running smoothly and is misfiring.</p>	<p>There is a malfunction in the engine electronics or in a mechanical component of the engine management system.</p> <p>► Only depress the accelerator pedal slightly. Otherwise, non-combusted fuel may get into the catalytic converter and damage it.</p> <p>► Have the cause rectified immediately at a qualified specialist workshop.</p>

Problem	Possible causes/consequences and ► Solutions
<p>The coolant temperature display is showing more than 120 °C. The coolant warning lamp may also be lit and a warning tone may sound.</p>	<p>The coolant level is too low. The coolant is too hot and the engine is no longer being cooled sufficiently.</p> <ul style="list-style-type: none"> ► Stop as soon as possible and allow the engine and the coolant to cool down. ► Check the coolant level (► page 363). Observe the warning notes as you do so and top up the coolant if necessary. <p>If the coolant level is correct, the radiator fan may be faulty. The coolant is too hot and the engine is no longer being cooled sufficiently.</p> <ul style="list-style-type: none"> ► At coolant temperatures under 120 °C, drive on to the nearest qualified specialist workshop, e.g. to a Mercedes-Benz Service Centre. ► Avoid heavy loads on the engine as you do so, e.g. driving in mountainous terrain and stop-start traffic.

Automatic transmission

Important safety notes

WARNING

If the engine speed is above the idling speed and you engage transmission position **D** or **R**, the vehicle could pull away suddenly. There is a risk of an accident.

When engaging transmission position **D** or **R**, always firmly depress the brake pedal and do not simultaneously accelerate.

DIRECT SELECT lever

Overview of transmission positions



P Park position with parking lock

R Reverse gear

N Neutral

D Drive

The DIRECT SELECT lever is on the right of the steering column.

 The DIRECT SELECT lever always returns to its original position. The current transmission position **P**, **R**, **N** or **D** appears in the transmission position display (► page 168) in the multifunction display.

Transmission position and drive program display

! If the transmission position display in the multifunction display is not working, you should pull away carefully to check whether the desired transmission position is engaged. Ideally, you should select transmission position **D** and, for AMG vehicles, drive program **C** or **S**. Do not restrict the shift range.



Transmission position and drive program display

- ① Transmission position display
- ② Drive program display

The current transmission position and drive program appear in the multifunction display.

i The arrows in the transmission position display show how and into which transmission positions you can change using the DIRECT SELECT lever.

Engaging park position P

! If the engine speed is too high, do not shift the automatic transmission directly from **D** to **R**, from **R** to **D** or directly to **P**. Otherwise, the automatic transmission could be damaged.



P Park position with parking lock

R Reverse gear

N Neutral

D Drive

► Push the DIRECT SELECT lever in the direction of arrow **P**.

i The automatic transmission shifts into park position **P** automatically:

- if you open the driver's door while the vehicle is stationary in transmission position **D** or **R**
- if you open the door while travelling at very low speeds in transmission position **D** or **R**

i If you depress the brake pedal and push the DIRECT SELECT lever up or down, the parking lock is released. The transmission is in **N** neutral.

In order to shift from park position **P** directly into **R** or **D**:

- depress the brake pedal and
- push the DIRECT SELECT lever up or down past the first point of resistance

Engaging park position P automatically

Park position **P** is automatically engaged if:

- you switch off the engine using the key and remove the key
- you switch off the engine using the Start/Stop button and open one of the front doors
- the HOLD (▷ page 211) or DISTRONIC PLUS (▷ page 198) function brake your

vehicle until it is stationary and at least one of the following conditions is fulfilled:

- there is a system malfunction
- the vehicle is on a steep uphill or downhill gradient. The electric parking brake is then also engaged.

Engaging reverse gear R

! Only shift the automatic transmission to **R** when the vehicle is stationary.

- ▶ Push the DIRECT SELECT lever up past the first point of resistance.

Neutral N with ECO start/stop function activated

The ECO start/stop function switches the engine off automatically if:

- the vehicle is braked until stationary while in neutral **N** and
- you continue to depress the brake pedal

For further information on the ECO start/stop function (▷ page 163).

Shifting to neutral (N)

- ▶ Push the DIRECT SELECT lever up or down to the first point of resistance.

Drive position D with ECO start/stop function activated

The ECO start/stop function switches the engine off automatically if:

- the vehicle is braked until stationary while in transmission position **D** and
- you continue to depress the brake pedal

For further information on the ECO start/stop function (▷ page 163).

Engaging drive position D

- ▶ Push the DIRECT SELECT lever down past the first point of resistance.

Transmission positions

P Park position

This prevents the vehicle from rolling away when stopped. Do not shift the transmission into position **P** (▷ page 181) unless the vehicle is stationary.

The automatic transmission shifts to **P** automatically if you:

- remove the key
- switch off the engine when in **R** or **D** and open one of the front doors

R Reverse gear

Only shift the transmission to **R** when the vehicle is stationary.

N Neutral

Do not shift the transmission to **N** while driving. Otherwise, the automatic transmission could be damaged.

No power is transmitted from the engine to the drive wheels.

Releasing the brakes will allow you to move the vehicle freely, e.g. to push it or tow it.

If ESP[®] is deactivated or faulty: only shift the transmission to position **N** if the vehicle is in danger of skidding, e.g. on icy roads.

If you switch off the engine using the key or the Start/Stop button, the automatic transmission shifts to neutral **N** automatically.

! Rolling in neutral **N** can lead to damage to the transmission.

D Drive

The automatic transmission changes gear automatically. All forward gears are available.

Changing gear

The automatic transmission shifts to the individual gears automatically when it is in transmission position **D**. Gearshifting is determined by:

- a possible limitation of the shift range
- the selected drive program
- the position of the accelerator pedal
- the road speed

Driving tips

Accelerator pedal position

Your style of driving influences how the automatic transmission shifts gear:

- little throttle: early upshifts
- more throttle: late upshifts

Kickdown

Use kickdown for maximum acceleration:

- ▶ Depress the accelerator pedal beyond the pressure point.
The transmission shifts to a lower gear depending on the engine speed.
- ▶ Ease off the accelerator pedal once the desired speed is reached.
The automatic transmission shifts back up.

Towing a trailer

- ▶ Drive in the middle of the engine speed range on uphill gradients.
- ▶ Shift down to shift range **3** or **2** (▷ page 171) depending on the uphill or downhill gradient, even if cruise control, DISTRONIC PLUS or SPEEDTRONIC is activated.

Program selector button

General notes



Program selector button on vehicles with the ON&OFFROAD package

- ▶ Press program selector button **Ⓢ**.
The letter **M** appears in the multifunction display. Manual drive program **M** is enabled.



Program selector button on AMG vehicles

- ▶ Press program selector button **Ⓢ** repeatedly until the letter for the desired gearshift program appears in the multifunction display.

The program selector button allows you to choose between different driving characteristics.

- i** Drive program **M** is not stored when the engine is switched off. If you want to use this drive program you will need to reactivate it after starting the engine.

Drive programs on AMG vehicles

C Controlled Efficiency	Comfortable, economical driving
S Sport	Sporty driving style
M Manual	Manual gearshifting

i For further information on the automatic drive program, see (▷ page 171).

Steering wheel gearshift paddles



In the automatic drive program, you can restrict or derestrict the shift range by using steering wheel gearshift paddles ① and ② (▷ page 171).

In the manual drive program (▷ page 172), you can change gears manually using steering wheel gearshift paddles ① and ②.

i You can only change gear with the steering wheel gearshift paddles when the transmission is in position **D**.

Automatic drive program (AMG vehicles)

Drive program **C** is characterised by the following:

- comfort-oriented engine and transmission settings.
- optimal fuel consumption resulting from the automatic transmission shifting up sooner

- the vehicle pulling away more gently in forward and reverse gears, unless the accelerator pedal is depressed fully
- increased sensitivity. This improves driving stability on slippery road surfaces, for example
- the automatic transmission shifting up sooner. This results in the vehicle being driven at lower engine speeds and the wheels being less likely to spin

Drive program **S** is characterised by the following:

- sporty engine and transmission settings
- the automatic transmission shifting up later
- as a result of the later automatic transmission shift points, the fuel consumption possibly being higher

Shift ranges

Introduction

In transmission position **D**, you can use the steering wheel gearshift paddle to restrict or derestrict the shift range for the automatic transmission (▷ page 171).

The shift range selected is shown in the multifunction display. The automatic transmission shifts only as far as the selected gear.

Driving situations

- | | |
|----------|--|
| 3 | To use the engine's braking effect |
| 2 | The braking effect of the engine can be utilised on downhill gradients or when driving: <ul style="list-style-type: none"> • on steep mountain roads • in mountainous terrain • in arduous conditions |
| 1 | The braking effect of the engine can be utilised on extremely steep downhill gradients and long downhill stretches. |

Restricting the shift range

- ▶ Pull the left-hand steering wheel gearshift paddle.

The automatic transmission shifts down one gear and restricts the shift range to the relevant gear.

- ❗ If the engine exceeds the maximum engine speed when shifting down, the automatic transmission protects against engine damage by not shifting down.
- ❗ If the maximum engine speed for the shift range is reached and you continue to accelerate, the automatic transmission shifts up, even if the shift range is restricted. This prevents the engine from overrevving.

Extending the shift range

- ▶ Pull the right-hand steering wheel gearshift paddle.
- The shift range is derestricted.

Clearing the shift range restriction

- ▶ Pull and hold the right-hand steering wheel gearshift paddle until **D** is shown again in the multifunction display.
- The automatic transmission shifts from the current shift range directly to **D**.

or

- ▶ Use the DIRECT SELECT lever to shift the transmission to position **D**.
- The automatic transmission shifts from the current shift range directly to **D**.

Selecting the ideal shift range

- ▶ Pull the left-hand steering wheel gearshift paddle and hold it in position.
- The automatic transmission shifts to the gear which allows optimum acceleration and deceleration. To do this, the automatic transmission shifts down one or more gears.

Manual drive program

Activating the manual drive program

In manual drive program **M**, you can change gear using the steering wheel gearshift paddles if the transmission is in position **D**. The current drive program and the engaged gear are shown in the multifunction display.

- ▶ **AMG vehicles:** press the program selector button (▷ page 170) until **M** appears in the multifunction display.
 - ▶ **Vehicles with the ON&OFFROAD package:** press the program selector button (▷ page 170).
- The letter **M** appears in the multifunction display.

Upshifting (all vehicles except AMG vehicles)

- ▶ Pull the right-hand steering wheel gearshift paddle (▷ page 171).
- The automatic transmission shifts up to the next gear.

Upshifting (AMG vehicles)

- ❗ In manual gearshift program **M**, the automatic transmission does not shift up automatically even when the engine limiting speed for the current gear is reached.
- When the engine limiting speed is reached, the fuel supply is cut to prevent the engine from overrevving. You must make sure that the engine speed does not reach the red area of the rev counter. Otherwise, there is a risk of engine damage.



- ① Gear indicator
- ② Upshift indicator

Before the engine speed reaches the red area, an upshift indicator will be shown in the multifunction display.

- ▶ If the colour in the speedometer multifunction display changes to red and the **UP** display message is shown, shift up a gear.

Downshifting

- ▶ Pull the left-hand steering wheel gearshift paddle (▷ page 171).
The automatic transmission shifts down to the next gear.

Maximum acceleration

- ▶ Pull the left-hand steering wheel gearshift paddle until the transmission selects the optimum gear for the current speed.
- i** If you slow down or stop without shifting down, the automatic transmission automatically shifts down.

Kickdown

You can also use kickdown for maximum acceleration in manual drive program **M**.

- ▶ Depress the accelerator pedal beyond the pressure point.
The transmission shifts to a lower gear depending on the engine speed.
 - ▶ Shift back up once the desired speed is reached.
- i All vehicles (except AMG vehicles):** if you apply full throttle, the automatic transmission shifts up to the next gear when the maximum engine speed is reached. This prevents the engine from overrevving.
- i AMG vehicles:** it is not possible to use kickdown in manual drive program **M**.

Deactivating the manual drive program

- ▶ **AMG vehicles:** press the program selector button (▷ page 170) repeatedly until **C** or **S** appears in the multifunction display.
- ▶ **Vehicles with the ON&OFFROAD package:** press the program selector button (▷ page 170).
M is no longer shown in the multifunction display.

Problems with the transmission

Problem	Possible causes/consequences and ► Solutions
The transmission has problems shifting gear.	The transmission is losing oil. ► Have the transmission checked at a qualified specialist workshop immediately.
The acceleration ability is deteriorating. The transmission no longer changes gear.	The transmission is in emergency mode. It is only possible to shift into second gear and reverse gear. ► Stop. ► Shift the transmission to position P . ► Switch off the engine. ► Wait at least ten seconds before restarting the engine. ► Shift the transmission to position D or R . If D is selected, the transmission shifts into second gear; if R is selected, the transmission shifts into reverse gear. ► Have the transmission checked at a qualified specialist workshop immediately.

Refuelling

Important safety notes

WARNING

Fuel is highly flammable. If you handle fuel incorrectly, there is a risk of fire and explosion.

You must avoid fire, naked flames, creating sparks and smoking. Switch off the engine and, if applicable, the auxiliary heating before refuelling.

WARNING

Fuels are poisonous and hazardous to health. There is a danger of injury.

Do not swallow fuel or let it come into contact with skin, eyes or clothing. Do not inhale fuel vapours. Keep fuels out of the reach of children.

If you or others come into contact with fuel, observe the following:

- Wash the fuel off any affected areas of skin with water and soap immediately.
- If you get fuel in your eyes, rinse them thoroughly with clean water immediately. Seek immediate medical attention.
- If fuel is swallowed, seek immediate medical attention. Do not induce vomiting.
- Change any clothing that has come into contact with fuel immediately.

WARNING

Vehicles with a diesel engine:

If you mix diesel fuel with petrol, the flash point of this fuel mixture is lower than that of pure diesel fuel. When the engine is running, components in the exhaust system may overheat unnoticed. There is a risk of fire.

Never refuel with petrol. Never add petrol to diesel fuel.

⚠ WARNING

Electrostatic charge can lead to the creation of sparks and to fuel vapours igniting. There is a risk of fire and explosion.

Touch the vehicle bodywork just before opening the fuel filler cap. This will discharge a possible electrostatic charge.

! Do not use petrol to refuel vehicles with a diesel engine. Do not use diesel to refuel vehicles with a petrol engine. Do not switch on the ignition if you accidentally refuel with the wrong fuel. Otherwise, the fuel will enter the fuel system. Even small amounts of the wrong fuel could result in damage to the fuel system and the engine. The repair costs are high. Notify a qualified specialist workshop and have the fuel tank and fuel lines drained completely.

! Overfilling the fuel tank could damage the fuel system.

! Take care not to spill any fuel on painted surfaces. You could otherwise damage the paintwork.

! Use a filter when adding fuel from a fuel can. The fuel lines and/or the diesel injection system could otherwise be blocked by particles from the fuel can.

If you overfill the fuel tank, fuel could spray out when the fuel pump nozzle is removed. Further information on fuel and on fuel grades can be found in the "Fuel" section (▷ page 423).

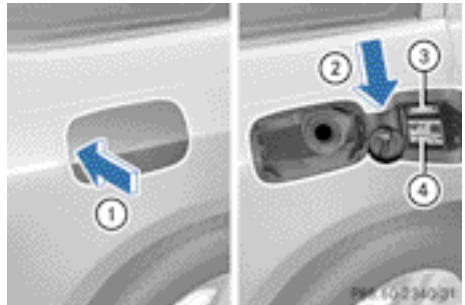
Refuelling**Opening/closing the fuel filler flap**

① To open the fuel filler flap

② To insert the fuel filler cap

③ Fuel type to be refuelled

④ Tyre pressure table

The fuel filler flap is unlocked or locked automatically when you open or close the vehicle with the key or using KEYLESS-GO.

The position of the fuel filler cap is displayed  in the instrument cluster. The arrow next to the filling pump indicates the side of the vehicle.

Opening

- ▶ Switch off the engine.
- ▶ Remove the key from the ignition lock.
- ▶ KEYLESS-GO: open the driver's door. This corresponds to key position **0**: "key removed".
The driver's door can be closed again.
- ▶ Press the fuel filler flap in the direction of arrow ①.
The fuel filler flap swings up.
- ▶ Turn the fuel filler flap anti-clockwise and remove it.
- ▶ Insert the fuel filler cap into the holder bracket on the inside of filler flap ②.
- ▶ Completely insert the filler neck of the fuel pump nozzle into the tank and refuel.
- ▶ Only fill the tank until the pump nozzle switches off.

- i** Do not add any more fuel after the pump stops filling for the first time. Otherwise, fuel may leak out.

Closing

- ▶ Replace the cap on the filler neck and turn clockwise until it engages audibly.
- ▶ Close the fuel filler flap.
- i** Close the fuel filler flap before locking the vehicle.

Problems with the fuel and fuel tank	
Problem	Possible causes/consequences and ► Solutions
Fuel is leaking from the vehicle.	<p>The fuel line or the fuel tank is faulty.</p> <p> WARNING</p> <p>Risk of explosion or fire.</p> <ul style="list-style-type: none"> ► Turn the key to position 0 in the ignition lock and remove it immediately (▷ page 159). ► Do not restart the engine under any circumstances. ► Consult a qualified specialist workshop.
The engine does not start.	<p>The fuel tank of a vehicle with a diesel engine has been run completely dry.</p> <ul style="list-style-type: none"> ► Refuel the vehicle with at least 5 litres of diesel. ► Turn the ignition on for approximately ten seconds (▷ page 159). ► Start the engine continuously for a maximum of ten seconds until it runs smoothly. <p>If the engine does not start:</p> <ul style="list-style-type: none"> ► Turn the ignition on again for a maximum of ten seconds (▷ page 159). ► Start the engine again continuously for a maximum of ten seconds until it runs smoothly. <p>If the engine does not start after three attempts:</p> <ul style="list-style-type: none"> ► Consult a qualified specialist workshop.
The fuel filler flap cannot be opened.	<p>The fuel filler flap is not unlocked.</p> <p>or</p> <p>The key battery is discharged.</p> <ul style="list-style-type: none"> ► Unlock the vehicle (▷ page 77). <p>or</p> <ul style="list-style-type: none"> ► Unlock the vehicle using the emergency key element (▷ page 78). <p>The fuel filler flap is unlocked, but the opening mechanism is jammed.</p> <ul style="list-style-type: none"> ► Consult a qualified specialist workshop.

AdBlue® (BlueTEC vehicles only)**Important notes on use**

To function properly, BlueTEC exhaust gas aftertreatment must be operated with the reducing agent AdBlue®.

When the supply of AdBlue® is almost used up, the **Refill AdBlue See Owner's Manual** message is shown in the multifunction display.

When the AdBlue® supply drops to a minimum, the **Refill AdBlue No start in XXXX km** message is shown in the multifunction display.

If the **Refill AdBlue No start in XXXX km** message is shown in the multifunction display, you can still drive the vehicle over the distance shown. If AdBlue® is not topped up, you will subsequently be **unable to start the engine**. Refill the AdBlue® tank or have the AdBlue® tank refilled at a qualified specialist workshop. If the **Refill AdBlue Eng. start not possible** message appears in the multifunction display and the engine does not start, you must top up with at least 3.8 l of AdBlue® (approximately 2 AdBlue® refill bottles).

i If you drive the vehicle faster than 15 km/h, the **Refill AdBlue See Owner's Manual** message goes out after approximately one minute.

If the outside temperature is lower than -11 °C, it may be difficult to top up. If AdBlue® is frozen and there is an active warning indicator, topping up may not be possible. Park the vehicle in a warm place, e.g. in a garage, until AdBlue® has become liquid again. Topping up is then possible again. Alternatively, have the AdBlue® tank refilled at a qualified specialist workshop.

Further information about BlueTEC exhaust gas aftertreatment and about AdBlue® can be obtained from any Mercedes-Benz Service Centre.

Important safety notes on the refilling procedure

AdBlue® is a water-soluble fluid for the exhaust gas aftertreatment of diesel engines. It is:

- not poisonous
- colourless and odourless
- not flammable

When you open the AdBlue® container, small amounts of ammonia vapour may be released.

Ammonia vapours have a pungent odour and are particularly irritating to the skin, to mucous membranes and to the eyes. You may experience a burning sensation in your eyes, nose and throat. Coughing and watering of the eyes are possible.

Do not inhale any ammonia vapours that may be released. Fill the AdBlue® tank only in well-ventilated areas.

AdBlue® must not come into contact with your skin, eyes or clothing and must not be swallowed. Keep AdBlue® away from children.

If you or other persons come into contact with AdBlue®, observe the following:

- Rinse AdBlue® from your skin immediately with soap and water.
- If AdBlue® comes into contact with your eyes, immediately rinse them thoroughly with clean water. Seek medical attention immediately.
- If AdBlue® has been swallowed, rinse your mouth out immediately. Drink plenty of water. Seek medical attention immediately.
- Change out of clothing contaminated with AdBlue® immediately.

! Only use AdBlue® in accordance with ISO 22241. Do not mix any additives with AdBlue®, and do not dilute AdBlue® with water. This may destroy the BlueTEC exhaust gas aftertreatment system.

! In order to fill the AdBlue® tank, the vehicle must be parked on a level surface. The AdBlue® tank can only be filled as intended with the vehicle parked on a level surface. Fluctuations in capacity will thus be avoided. Filling a vehicle standing on an uneven surface is not permitted. There is a danger of overfilling, which can cause damage to BlueTEC exhaust gas aftertreatment components.

! Surfaces which have come into contact with AdBlue® while refilling should be rinsed immediately with water, or remove AdBlue® with a moist cloth and cold water. If AdBlue® has already crystallised, use a sponge and cold water to clean the area. AdBlue® residue crystallises after a certain amount of time and soils the affected surfaces.

! AdBlue® is not a fuel additive and must not be added to the fuel tank. If AdBlue® is added to the fuel tank, this can lead to engine damage.

Have the AdBlue® tank refilled at a qualified specialist workshop. However, you can also top up the AdBlue® tank:

- at a filling station with an AdBlue® filling pump
- with AdBlue® refill bottles
- with an AdBlue® refill canister

When the pump nozzle switches off automatically during filling at a filling pump, the AdBlue® tank has been completely filled. Do not fill the AdBlue® tank any further. AdBlue® may leak out.

For further information on AdBlue®, see (▷ page 427).

Opening the AdBlue® filler cap

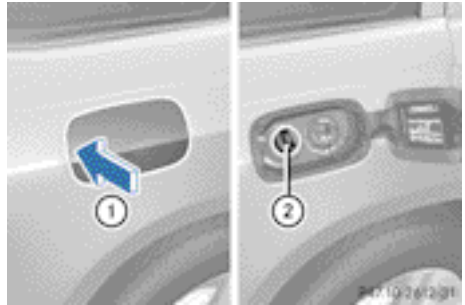

The fuel filler flap is unlocked or locked automatically when you open or close the vehicle with the key or using KEYLESS-GO.

- ▶ Switch the ignition off.
- ▶ Press the fuel filler flap in the direction of arrow ①.
The fuel filler flap swings up.
- ▶ Turn blue AdBlue® filler cap ② anti-clockwise and remove it.
AdBlue® filler cap ② is secured with a plastic strip.

AdBlue® refill canisters

! Do not tighten the disposable hose with too much force. The disposable hose may otherwise be destroyed.

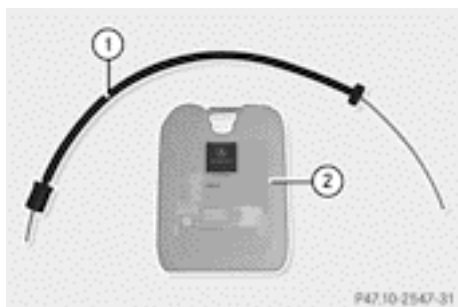

- ▶ Unscrew the cap from the opening on top of AdBlue® refill canister (2).
- ▶ Place disposable hose (1) on the opening of AdBlue® refill canister (2) and screw it on clockwise until hand-tight.
- i** Disposable hose (1) remains closed until you fasten disposable hose (1) to the AdBlue® filler neck of the vehicle.
- ▶ Place disposable hose (1) on the filler neck on the vehicle and screw it on clockwise until hand-tight. When you feel resistance, disposable hose (1) is sufficiently secured.
- ▶ Lift up and tip AdBlue® refill canister (2).
- i** Filling stops when the AdBlue® tank is completely filled. Do not fill the AdBlue® tank any further. AdBlue® refill canister (2) can be removed when it has been only partially emptied.
- ▶ Turn disposable hose (1) on the filler neck of the vehicle anti-clockwise and remove it.

- ▶ Turn disposable hose (1) on the opening of AdBlue® refill canister (2) anti-clockwise and remove it.
- ▶ Reseal AdBlue® refill canister (2) with the cap.

AdBlue® refill canisters can be obtained at many filling stations or at a Mercedes-Benz Service Centre. AdBlue® refill canisters are often sold with a filler hose. A filler hose that does not exactly fit the vehicle's AdBlue® tank offers no protection against overfilling. AdBlue® may leak out as a result of overfilling. Mercedes-Benz offers a special disposable hose with overfill protection. You can obtain this from any Mercedes-Benz Service Centre. AdBlue® is available in a variety of containers and receptacles. Only use the disposable hose with Mercedes-Benz AdBlue® refill canisters.

AdBlue® refill bottle

- i** Screw on the AdBlue® refill bottle only hand-tight. It may otherwise be destroyed.

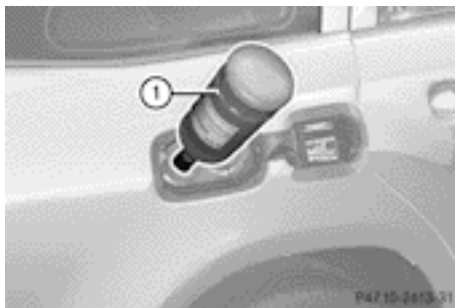

- ▶ Unscrew the protective cap from AdBlue® refill bottle (1).
- ▶ Place AdBlue® refill bottle (1) on the filler neck as shown and screw it on hand-tight.
- ▶ Press AdBlue® refill bottle (1) towards the filler neck.

The AdBlue® tank is filled. This could last up to one minute.

- i** When AdBlue® refill bottle (1) is no longer pressed, filling stops and the bottle may be

taken off again after being only partially emptied.

- ▶ Release AdBlue® refill bottle ①.
- ▶ Turn AdBlue® refill bottle ① anti-clockwise and remove it.
- ▶ Screw the protective cap onto AdBlue® refill bottle ① again.

AdBlue® refill bottles can be obtained at many filling stations or at a Mercedes-Benz Service Centre. Refill bottles without a threaded seal offer no protection against overfilling. AdBlue® may leak out as a result of overfilling. Mercedes-Benz offers special refill bottles with a threaded seal. These are available at any Mercedes-Benz Service Centre.

Closing the AdBlue® filler cap

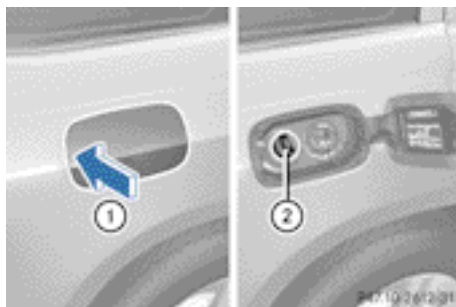

- ▶ Fit AdBlue® filler cap ② on the filler neck and turn it clockwise.
- ▶ To close the fuel filler flap, press it in the direction of arrow ①.
- ▶ Drive faster than 15 km/h.
The [Refill AdBlue See Owner's Manual](#) message goes out after approximately one minute.
- ▶ **i** If the [Refill AdBlue See Owner's Manual](#) message continues to be shown in the multifunction display, you must top up with more AdBlue®.

Parking

Important safety notes

⚠ WARNING

If flammable materials such as leaves, grass or twigs are exposed to prolonged contact to parts of the exhaust system that heat up, they could ignite. There is a risk of fire.

Park the vehicle so that no flammable materials come into contact with parts of the vehicle which are hot. Take particular care not to park on dry grassland or harvested grain fields.

⚠ WARNING

If you switch off the ignition while driving, safety-relevant functions are only available with limitations, or not at all. This could affect, for example, the power steering and the brake boosting effect. You will require considerably more effort to steer and brake. There is a risk of an accident.

Do not switch off the ignition while driving.

⚠ WARNING

If you leave children unsupervised in the vehicle, they could set it in motion by, for example:

- releasing the parking brake
- shifting the automatic transmission out of the parking position **P**
- starting the engine.

They could also operate the vehicle's equipment. There is a risk of an accident and injury.

When leaving the vehicle, always take the key with you and lock the vehicle. Never leave children unsupervised in the vehicle.

- ▶ **!** A moving vehicle can lead to damage to the vehicle or damage to the drive train.

To ensure that the vehicle is secured against rolling away unintentionally:

- the electric parking brake must be applied
- the transmission must be in position **P** and the key must be removed from the ignition lock
- on steep uphill or downhill gradients, turn the front wheels towards the kerb
- on steep uphill or downhill gradients, the front axle of an empty vehicle must be secured, for example with a wheel chock
- on steep uphill or downhill gradients, the rear axle of a laden vehicle must be additionally secured, for example with a wheel chock.

Switching off the engine

Important safety notes

WARNING

The automatic transmission switches to neutral position **N** when you switch off the engine. The vehicle may roll away. There is a risk of an accident.

After switching off the engine, always switch to parking position **P**. Prevent the parked vehicle from rolling away by applying the parking brake.

Using the key

- ▶ Engage the electric parking brake.
 - ▶ Shift the transmission to position **P**.
 - ▶ Turn the key to position **0** in the ignition lock and remove it.
The immobiliser is activated.
- i** If you switch the engine off with the transmission in position **R** or **D**, the automatic transmission shifts to **N** automatically. If you then open one of the front doors or remove the key from the ignition, the automatic transmission shifts to **P**.
- If you shift the automatic transmission to **N** before switching off the engine, the auto-

matic transmission remains in **N** even if a door is opened.

Using KEYLESS-GO

- ▶ Engage the electric parking brake.
 - ▶ Shift the transmission to position **P**.
 - ▶ Press the Start/Stop button (▷ page 159). The engine stops and all the indicator lamps in the instrument cluster go out.
- i** If you use the Start/Stop button to switch off the engine, the automatic transmission shifts to **N** automatically. If you then open one of the front doors, the automatic transmission shifts to **P**.
- i** The engine can be switched off while the vehicle is in motion by pressing and holding the Start/Stop button for about three seconds. This function operates independently of the ECO start/stop automatic engine switch-off function.

Electric parking brake

General notes

WARNING

If you leave children unsupervised in the vehicle, they could set it in motion by, for example:

- releasing the parking brake
- shifting the automatic transmission out of the parking position **P**
- starting the engine.

They could also operate the vehicle's equipment. There is a risk of an accident and injury. When leaving the vehicle, always take the key with you and lock the vehicle. Never leave children unsupervised in the vehicle.

- i** The electric parking brake carries out a function check at regular intervals when the engine is switched off. Noises that occur are normal.

Engaging/releasing manually

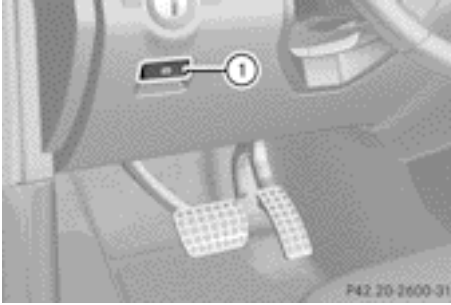

► To engage: push handle ①.

When the electric parking brake is engaged, the  red indicator lamp lights up in the instrument cluster.

i The electric parking brake can also be applied when the key is removed.

► To release: pull handle ①.

The red  indicator lamp in the instrument cluster goes out.

i The electric parking brake can only be released:

- when the key is in position **1** in the ignition lock or
- the ignition was switched on using the Start/Stop button.

To ensure that you do not roll backwards when pulling away on an uphill slope, engage the electric parking brake (► page 162).

Engaging automatically

The electric parking brake is engaged automatically:

- if DISTRONIC PLUS brings the vehicle to a standstill or
- if the HOLD function is keeping the vehicle stationary

In addition, at least one of the following conditions must be fulfilled:

- the engine is switched off.
- the driver's door is open and the seat belt is not fastened.
- the vehicle is stationary for a lengthy period.

The red  indicator lamp in the instrument cluster lights up.

i The electric parking brake is not automatically applied if the engine is switched off by the ECO start/stop function.

Releasing automatically

The electric parking brake is released automatically when all of the following conditions are fulfilled:

- the engine is running.
- the transmission is in position **D** or **R**.
- the seat belt is fastened.
- you depress the accelerator pedal.

If the transmission is in position **R**, the boot lid must be closed.

If your seat belt is not fastened, the following conditions must be fulfilled to automatically release the electric parking brake:

- the driver's door is closed
- you have shifted out of transmission position **P** or you have previously driven faster than 3 km/h

Emergency braking



- ▶ While driving, push handle ① of the electric parking brake.

The vehicle can also be braked during an emergency using the electric parking brake.

- ❗ The vehicle is braked for as long as the handle of the electric parking brake is pressed. The longer the electric parking brake handle is depressed, the greater the braking force.

During braking:

- a warning tone sounds
- the **Release park. brake** message appears
- the red  indicator lamp in the instrument cluster flashes

When the vehicle has been braked to a standstill, the electric parking brake is engaged.

Parking up the vehicle

If you leave the vehicle parked up for longer than four weeks, the battery may be damaged by exhaustive discharging.

- ▶ Disconnect the battery or connect it to a trickle charger.
- ❗ You can obtain information about trickle chargers from a qualified specialist workshop.

If you leave the vehicle parked up for longer than six weeks, the vehicle may suffer damage as a result of lack of use.

- ▶ Visit a qualified specialist workshop and seek advice.

Driving tips

General notes

Important safety notes

WARNING

If you switch off the ignition while driving, safety-relevant functions are only available

with limitations, or not at all. This could affect, for example, the power steering and the brake boosting effect. You will require considerably more effort to steer and brake. There is a risk of an accident.

Do not switch off the ignition while driving.

Drive sensibly – save fuel

Observe the following tips to save fuel:

- ▶ The tyres should always be inflated to the recommended tyre pressure.
- ▶ Remove unnecessary loads.
- ▶ Remove roof carriers when they are not needed.
- ▶ Warm up the engine at low engine speeds.
- ▶ Avoid frequent acceleration or braking.
- ▶ observe the service intervals in the Service Booklet or in the service interval display. Have all the maintenance work carried in accordance with Daimler AG regulations.

Fuel consumption also increases when driving in cold weather, in stop-start traffic and in hilly terrain.

Short journeys

- ❗ **Vehicles with a diesel particle filter:** if the vehicle is mostly driven for short distances, it is possible that malfunctions may occur during the automatic cleaning of the diesel particle filter. This may lead to fuel collecting in the engine oil and cause engine failure. Therefore, if you frequently drive short distances, you should take a 20 minute trip on a motorway or rural road at least every 500km.

Braking

Important safety notes

WARNING

If you shift down on a slippery road surface in an attempt to increase the engine's braking

effect, the drive wheels could lose their grip. This increases the risk of skidding and having an accident.

Do not shift down for additional engine braking on a slippery road surface.

Downhill gradients

Do not depress the brake pedal continuously while the vehicle is in motion, e.g. causing the brakes to rub by constantly applying light pressure to the pedal. This results in excessive and premature wear to the brake pads.

On long and steep downhill gradients, you must select shift range **1**, **2** or **3** in good time. Take particular note of this when driving a laden vehicle.

i This also applies if you have activated cruise control, SPEEDTRONIC or DIS-TRONIC PLUS.

This will use the braking effect of the engine, so less braking will be required to prevent the vehicle from gaining speed. This relieves the load on the brake system and prevents the brakes from overheating and wearing too quickly.

Heavy and light loads

WARNING

The braking system can overheat if you leave your foot on the brake pedal while driving. This increases the braking distance and could even cause the braking system to fail. There is a risk of an accident.

Never use the brake pedal as a footrest. Do not simultaneously depress both the brake pedal and the accelerator pedal while driving.

! Depressing the brake pedal constantly results in excessive and premature wear to the brake pads.

If the brakes have been subjected to a heavy load, do not stop the vehicle immediately. Drive on for a short while. This allows the airflow to cool the brakes more quickly.

If the brakes have been used only moderately, you should occasionally test their effectiveness. To do this, brake more firmly from a higher speed. This improves the grip of the brakes.

Wet road surfaces

If you have driven for a long time in heavy rain without braking, there may be a delayed reaction from the brakes when braking for the first time. This may also occur after a car wash or after driving through deep water.

You then have to depress the brake pedal more firmly. Maintain a greater distance from the vehicle in front.

After driving on a wet road or having the vehicle washed, brake firmly while paying attention to the traffic conditions. This will warm up the brake discs, thereby drying them more quickly and protecting them against corrosion.

Limited braking performance on salt-treated roads

If you drive on salted roads, a layer of salt residue may form on the brake discs and brake pads. This can result in a significantly longer braking distance.

- Brake occasionally to remove any possible salt residue. Make sure that you do not endanger other road users when doing so.
- Carefully depress the brake pedal at the beginning and end of a journey.
- Maintain a greater distance to the vehicle ahead.

New brake pads/linings

New and replaced brake pads and discs only reach their optimum braking effect after several hundred kilometres of driving. Compensate for this by applying greater force to the brake pedal.

For safety reasons, Mercedes-Benz recommends that you only have brake pads/linings fitted to your vehicle which have been

approved for Mercedes-Benz vehicles or which correspond to an equivalent quality standard. Brake pads/linings which have not been approved for Mercedes-Benz vehicles or which are not of an equivalent quality could affect your vehicle's operating safety.

High-performance brake system for AMG vehicles

The high-performance brake system is designed for high loads. This may lead to noise when braking. This is dependent on:

- speed
- braking force
- environmental conditions, such as temperature and humidity

The wear of individual brake system components such as the brake pads/linings or brake discs depends on individual driving style and operating conditions.

For this reason, it is impossible to state a mileage (service life) that will be valid under all circumstances. An aggressive driving style will lead to high wear. You can obtain further information about this from your Mercedes-Benz Service Centre.

New brake pads/brake pads and discs that have been replaced only achieve optimum braking effect after several hundred kilometres of driving. Compensate for the reduced braking effect by applying greater force to the brake pedal. Always be aware of this and adapt your driving and braking accordingly during the running-in period.

Excessive heavy braking results in correspondingly high brake wear. Observe the  brake wear warning lamp in the instrument cluster and note any brake status messages in the multifunction display. If you regularly drive at high speeds, it is particularly important to have the brake system checked and maintained regularly.

Driving on wet roads

Aquaplaning

If water has accumulated to a certain depth on the road surface, there is a danger of aquaplaning occurring, even if:

- you are driving at low speeds
- the tyres have adequate tread depth.

For this reason, do not drive in tyre ruts, and brake carefully.

Driving on flooded roads

! Bear in mind that vehicles travelling in front or in the opposite direction create waves. This may cause the maximum permissible water depth to be exceeded.

These notes must be observed under all circumstances. You could otherwise damage the engine, the electronics or the transmission.

If you have to drive on stretches of road on which water has collected, please bear in mind that:

- the maximum permissible fording depth in still water depends on the vehicle equipment.
- you should drive no faster than walking pace.

Off-road fording

! The depth of water must not exceed the value specified in the table. Note that the possible fording depth is less in flowing water.

! Under no circumstances should you accelerate before entering the water. The bow wave could cause water to enter and damage the engine and neighbouring assemblies.

! Do not open any of the vehicle's doors while fording. Otherwise, water could get into the vehicle interior and damage the

vehicle's electronics and interior equipment.



The table shows fording depth ① when loaded and ready to drive.

When the vehicle is loaded and ready to drive, it has a full tank, all fluids have been topped up and the driver is in the vehicle.

On vehicles with the AIRMATIC package or the ON&OFFROAD package, loads up to the maximum permissible load have no influence on fording capability ①.

	Fording depth
Vehicles without the ON&OFFROAD package	
Raised level	50 cm
Vehicles with the ON&OFFROAD package	
Off-road level 3	60 cm
Off-road level 2	50 cm
Off-road level 1	50 cm

- Establish how deep the water is and the characteristics of the body of water before fording.
- Select the highest possible vehicle level.
- Restrict the shift range to **1** or **2**.
- Avoid high engine speeds.
- Enter and exit the water at a flat place and at a steady walking pace.

- Drive slowly and at a constant speed through the water.
- Do not stop.
- Water offers a high degree of resistance, the ground is slippery and, in some cases, unstable. Therefore, it is difficult and dangerous to pull away in the water.
- Ensure that a bow wave does not form as you drive.
- Clean any mud from the tyre tread after fording.
- Apply the brakes to dry them after fording.

Winter driving

General notes

WARNING

If you shift down on a slippery road surface in an attempt to increase the engine's braking effect, the drive wheels could lose their grip. This increases the risk of skidding and having an accident.

Do not shift down for additional engine braking on a slippery road surface.

DANGER

If the exhaust pipe is blocked or adequate ventilation is not possible, poisonous gases such as carbon monoxide (CO) may enter the vehicle. This is the case, e.g. if the vehicle becomes trapped in snow. There is a risk of fatal injury.

If you leave the engine or the auxiliary heating running, make sure the exhaust pipe and area around the vehicle are clear of snow. To ensure an adequate supply of fresh air, open a window on the side of the vehicle that is not facing into the wind.

- ❗ Take care not to damage the sealing strip and the moulding on the side of the rear window when scraping ice off the rear window.

At the onset of winter, have your vehicle winterproofed at a qualified specialist workshop.

Vehicles with the ON&OFFROAD package: if driving in snow or with snow chains, select the snow program (▷ page 249) with the off-road program selector wheel in the centre console.

Observe the notes in the "Winter operation" section (▷ page 398).

Driving with summer tyres

Observe the notes in the "Winter operation" section (▷ page 398).

Slippery road surfaces

WARNING

If you shift down on a slippery road surface in an attempt to increase the engine's braking effect, the drive wheels could lose their grip. This increases the risk of skidding and having an accident.

Do not shift down for additional engine braking on a slippery road surface.

If the vehicle threatens to skid or cannot be stopped when moving at low speed:

- ▶ Move the transmission to position **N**.
- ▶ Try to bring the vehicle under control by using corrective steering.

 For more information on driving with snow chains, see (▷ page 399).

You should drive particularly carefully on slippery road surfaces. Avoid sudden acceleration, steering and braking manoeuvres.

Off-road driving

Important safety notes

WARNING

If you drive up a steep incline at an angle or turn on a steep incline, the vehicle could slip

sideways, tip and overturn. There is a risk of an accident.

When driving up an incline, drive into the line of fall (upwards or downwards in a straight line) and do not turn.

WARNING

If the vehicle level is high, the vehicle centre of gravity is raised. This could cause the vehicle to tip over more easily on uphill or downhill gradients. There is a risk of an accident.

Select the lowest possible vehicle level.

When driving off-road, sand, mud and water, possibly mixed with oil, for example, could get into the brakes. This could result in a reduced braking effect or in total brake failure and also in increased wear and tear. The braking characteristics change depending on the material ingressing the brakes. Clean the brakes after driving off-road. If you detect a reduced braking effect or grinding noises, have the brake system checked in a qualified specialist workshop as soon as possible. Adapt your driving style to the different braking characteristics.

Driving off-road increases the likelihood of damage to the vehicle, which, in turn, can lead to failure of the mechanical assembly or systems. Adapt your driving style to suit the terrain conditions. Drive carefully. Have damage to the vehicle rectified immediately at a qualified specialist workshop.

Do not switch to transmission position **N** when driving off-road. You could lose control of the vehicle if you attempt to brake using the service brake. If the gradient is too steep, drive backwards in reverse gear.

General notes

Environmental note

Protection of the environment is of primary importance. Treat nature with respect. Observe all prohibiting signs.

Read this section before driving your vehicle off-road. Practise by travelling over more gentle off-road terrain first.

The following driving systems are specially adapted to off-road driving:

- Off-road program (vehicles without the ON&OFFROAD package) (▷ page 252)
- Off-road program 1 and 2 (vehicles with the ON&OFFROAD package) (▷ page 253)
- LOW RANGE off-road gear (vehicles with the ON&OFFROAD package) (▷ page 254)
- Differential lock (vehicles with the ON&OFFROAD package) (▷ page 254)
- Off-road ABS (▷ page 61)
- Off-road 4ETS (▷ page 66)
- Off-road ESP® (▷ page 67)
- AIRMATIC package (vehicle level) (▷ page 212)
- DSR (Downhill Speed Regulation) (▷ page 251)

Observe the following notes:

- Stop your vehicle and, if necessary, select the off-road program (▷ page 252) or the LOW RANGE off-road gear (▷ page 254) before driving off-road.
- Select a vehicle level suitable for the off-road terrain. To avoid damaging the vehicle, make sure there is always sufficient ground clearance.
- Check that items of luggage and loads are stowed safely and are well secured (▷ page 343).
- Always keep the engine running and in gear when driving on a downhill gradient. Activate DSR (▷ page 251).
- Drive slowly and evenly, if necessary at walking pace.
- Ensure that the wheels are in contact with the ground at all times.
- Drive with extreme care on unknown off-road routes where visibility is poor. For safety reasons, get out of the vehicle first and survey the off-road route.

- Check the depth of water before fording rivers and streams.
- Look out for obstacles such as rocks, holes, tree stumps and furrows.
- Take care when turning on an uphill or downhill slope or when driving across a slope. The vehicle could otherwise tip over.
- Always keep the side windows and the panorama sliding sunroof closed during the journey.
- Do not stray from marked routes or paths.

i Information about retrofitting special all-terrain tyres is available from any qualified specialist workshop.

i Do not use the HOLD function when driving off-road, on steep uphill or downhill gradients or on slippery or loose surfaces. The HOLD function cannot hold the vehicle on such surfaces.

Checklist before driving off-road

- ▶ **Engine oil level:** check the engine oil and top it up if necessary.
When driving on steep gradients, the engine oil level must be sufficiently high to ensure a correct oil supply in the vehicle.
- ▶ **AdBlue® tank (BlueTEC vehicles):** check the fluid level and, if necessary, refill to the maximum (13 l) (▷ page 178).
- ▶ **Tyre-change tool kit:** check that the jack is working and make sure you have the wheelbrace, a robust tow cable and a folding spade in the vehicle.
- ▶ **Wheels and tyres:** check the tyre tread depth and tyre pressure.
- ▶ Check for damage and remove any foreign objects, e.g. small stones, from the wheels/tyres.
- ▶ Replace any missing valve caps.
- ▶ Replace dented or damaged wheels.
- ▶ **Wheels:** dented or bent wheels can lead to a loss of tyre pressure and damage to the tyre bead. Before driving off-road, check the wheels and replace them if necessary.

Checklist after driving off-road

! If you detect damage to the vehicle after driving off-road, have the vehicle checked immediately at a qualified specialist workshop.

- ▶ **Vehicles with the ON&OFFROAD package:** activate the on-road program (▷ page 253).
- ▶ **Vehicles without the ON&OFFROAD package:** deactivate the on-road program (▷ page 252).
- ▶ Deactivate the LOW RANGE off-road gear (▷ page 254).
- ▶ Deactivate DSR (▷ page 251).
- ▶ Lower the vehicle level again to a level suitable to the road conditions, e.g. to the highway/high-speed level.
- ▶ Clean the headlamps and rear lights and check for damage.
- ▶ Clean the front and rear licence plates.
- ▶ Clean the wheels/tyres with a water jet and remove any foreign objects.
- ▶ Clean the wheels, wheel arches and the vehicle underside with a water jet; check for any foreign objects and damage.
- ▶ Check whether twigs or other parts of plants have become trapped. These increase the risk of fire and can damage fuel pipes, brake hoses or the rubber bellows of the axle joints and propeller shafts.
- ▶ After the trip, examine without fail the entire undercarriage, wheels, tyres, brakes, bodywork structure, steering, chassis and exhaust system for damage.
- ▶ After driving for extended periods across sand, mud, gravel, water or in similarly dirty conditions, have the brake discs, wheels, brake pads/linings and axle joints checked and cleaned.
- ▶ If you detect strong vibrations after off-road travel, check for foreign objects in the wheels and drive train and remove them if necessary. Foreign objects can disturb the balance and cause vibrations.

Driving over rough terrain places greater demands on your vehicle than driving on normal roads. After driving off-road, check the vehicle. This allows you to detect damage promptly and reduce the risk of an accident to yourself and other road users.

Driving on sand

Observe the following rules when driving on sand:

- **vehicles with the ON&OFFROAD package:** select off-road program 1 (▷ page 253).
- **vehicles without the ON&OFFROAD package:** select the off-road program (▷ page 252).
- select a higher vehicle level.
- select a shift range appropriate to the terrain.
- drive quickly to overcome the rolling resistance. Otherwise, the vehicle's wheels could become stuck in loose ground.
- drive in the tracks of other vehicles if possible. Make sure that:
 - the tyre ruts are not too deep.
 - the sand is sufficiently firm.
 - the ground clearance of the vehicle is sufficient.

Tyre ruts and gravel roads

! Check that the ruts are not too deep and that your vehicle has sufficient clearance. Otherwise, your vehicle could be damaged or bottom out and get stuck.

Observe the following rules when driving along ruts in off-road terrain or on roads with loose gravel:

- Activate the off-road program (▷ page 252).
- **Vehicles with the AIRMATIC package:** select a raised vehicle level.
- Avoid high engine speeds.
- Restrict the shift range to 1.

- Drive slowly.
- Where ruts are too deep, drive with the wheels on one side on the middle section of turf if possible.

Driving over obstacles

! Obstacles could damage the floor of the vehicle or components of the chassis. Ask passengers for guidance when driving over large obstacles. Any damage to the vehicle always increases the risk of an accident.

Observe the following rules when driving over tree stumps, large stones and other obstacles:

- Select the off-road program (▷ page 252) or the LOW RANGE off-road gear (▷ page 254).
- Raise the vehicle level.
- Avoid high engine speeds.
- Restrict the shift range to **1**.
- Drive very slowly.
- Drive straight over the centre of obstacles.

Travelling uphill

Approach/departure angle

⚠ WARNING

If you drive up a steep incline at an angle or turn on a steep incline, the vehicle could slip sideways, tip and overturn. There is a risk of an accident.

When driving up an incline, drive into the line of fall (upwards or downwards in a straight line) and do not turn.



The table shows approach/departure angles ① and ② loaded and ready to drive.

On vehicles with the AIRMATIC package or the ON&OFFROAD package, loads up to the maximum permissible load have no influence on approach and departure angles.

All vehicles (except AMG vehicles and vehicles AMG bodystyling)

	①	②
Vehicles without the ON&OFFROAD package		
Highway level	25°	20°
Raised level	30°	25°
Vehicles with the ON&OFFROAD package		
Highway level	25°	20°
Off-road level 1	28°	23°
Off-road level 2	30°	25°
Off-road level 3	33°	27°

Vehicles with AMG bodystyling

	①	②
Vehicles without the ON&OFFROAD package		
Highway level	20°	20°
Raised level	24°	24°

	①	②
Vehicles with the ON&OFFROAD package		
Highway level	20°	20°
Off-road level 1	22°	22°
Off-road level 2	24°	24°
Off-road level 3	26°	26°

AMG vehicles

	①	②
Highway level (AMG RIDE CONTROL sports mode)	19°	19°
Raised level	23°	22°

- Follow the line of fall when driving on slopes and steep inclines.
- Before driving on extreme uphill and downhill gradients, select the off-road program (> page 252) or the LOW RANGE off-road gear (> page 254).
- Observe the warnings for off-road driving (> page 188).
- Drive slowly.
- Accelerate gently and make sure that the wheels are gripping.
- Avoid high engine speeds, except when driving on sandy and muddy routes with high driving resistance.
- Select a shift range appropriate to the gradient.
- Before tackling steep downhill gradients, select shift range 1.

Do not shift into transmission position **N** when driving off-road. You could lose control of the vehicle if you attempt to brake the vehicle using the service brake. If the gradient is too steep for your vehicle, back up in reverse gear.

Maximum gradient-climbing capability

On good road surfaces and with the LOW RANGE off-road gear selected, the full gradient-climbing capability is available.

- ❗ If the load on the front axle is reduced when pulling away on a steep uphill slope, the front wheels have a tendency to spin. 4ETS recognises this and brakes the wheels accordingly. The rear wheel torque is increased and it is easier to pull away.

Hilltops

When driving up an uphill gradient, slightly reduce pressure on the accelerator immediately before reaching the brow of the hill. Make use of the vehicle's own impetus to travel over the brow.

This style of driving prevents:

- the vehicle from lifting off the ground on the brow of a hill
- the vehicle from travelling too quickly down the other side.

Driving downhill

- Drive slowly.
- Do not drive at an angle down steep inclines. Steer into the line of fall and drive with the front wheels aligned straight. Otherwise, the vehicle could slip sideways, tip and overturn.
- Before tackling steep downhill gradients, select shift range 1.
- Activate DSR. If this is not sufficient, brake gently. When doing so, make sure that the vehicle is facing in the direction of the line of fall.
- Check that the brakes are working normally after a long downhill stretch.

- ❗ Off-road ABS is activated when the off-road program or LOW RANGE off-road gear is selected.

At speeds below 30 km/h, the front wheels lock cyclically during braking. The digging-

in effect achieved in the process reduces the stopping distance when driving off-road. The steerability of the vehicle is considerably reduced if the wheels lock.

Driving systems

Cruise control

Important safety notes

WARNING

Do not change down for additional engine braking on a slippery road surface. This could cause the drive wheels to lose their grip and the vehicle could skid.

WARNING

Cruise control cannot take account of road and traffic conditions.

Always pay attention to traffic conditions even when cruise control is activated.

Cruise control is only an aid designed to assist driving. You are responsible for the vehicle's speed and for braking in good time.

WARNING

Do not use cruise control

- in traffic conditions that do not allow you to drive at a constant speed (e.g. heavy traffic or winding roads). You may otherwise cause an accident.
- on slippery roads. The drive wheels may lose their grip when braking or accelerating and the vehicle may skid.
- when there is low visibility, e.g. due to fog, heavy rain or snow.

General notes

Cruise control maintains a constant road speed for you. It brakes automatically in order to avoid exceeding the set speed. On long and steep downhill gradients, especially if the vehicle is laden or towing a trailer, you must select shift range **1**, **2** or **3** in good time. By

doing so, you will make use of the braking effect of the engine. This relieves the load on the brake system and prevents the brakes from overheating and wearing too quickly.

Use cruise control only if road and traffic conditions make it appropriate to maintain a steady speed for a prolonged period. You can store any road speed above 30 km/h.

Cruise control lever

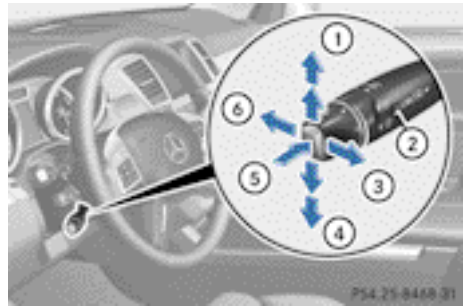

- ① To activate or increase speed
- ② LIM indicator lamp
- ③ To activate at the current speed/last stored speed
- ④ To activate or reduce speed
- ⑤ To switch between cruise control and variable SPEEDTRONIC
- ⑥ To deactivate cruise control

You can operate cruise control and variable SPEEDTRONIC with the cruise control lever.

- **To switch between variable SPEEDTRONIC and cruise control:** press the cruise control lever in the direction of arrow ⑤.

LIM indicator lamp ② on the cruise control lever indicates which function you have selected:

- **LIM indicator lamp ② off:** cruise control is selected.
- **LIM indicator lamp ② on:** variable SPEEDTRONIC is selected.

When you activate cruise control, the stored speed is shown in the multifunction display

for five seconds. In the multifunction display, the segments between the stored speed and the maximum speed light up.

Activation conditions

To activate cruise control, all of the following activation conditions must be fulfilled:

- the electric parking brake must be released.
- you are driving faster than 30 km/h.
- ESP® must be switched on, but not intervening.
- the transmission must be in position **D**.
- DSR must be deactivated.
- off-road program 2 must be deactivated (vehicles with the ON&OFFROAD package).
- the cruise control function must be selected (▷ page 193).

Storing, maintaining and calling up a speed

Storing and maintaining the speed

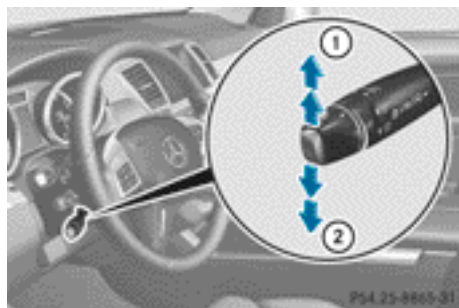

- ▶ Accelerate the vehicle to the desired speed.
- ▶ Briefly press the cruise control lever up ① or down ②.
- ▶ Remove your foot from the accelerator pedal.
Cruise control is activated. The vehicle automatically maintains the stored speed.

You can accept the current speed if you are driving faster than 30 km/h.

- ❗ Cruise control may be unable to maintain the stored speed on uphill gradients. The stored speed is resumed when the gradient evens out. Cruise control maintains the stored speed on downhill gradients by automatically applying the brakes.

Storing or calling up the speed

⚠ WARNING

Only call up a stored speed if you know what that speed is and if it is suitable for the current traffic and driving situation. You can otherwise endanger yourself or others by unintentionally triggering sudden acceleration or braking.

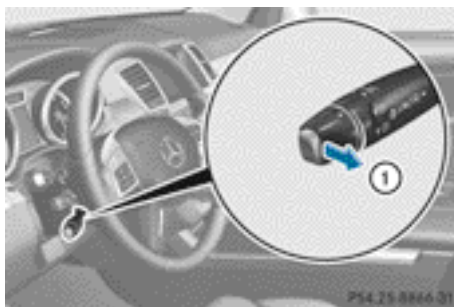

- ▶ Briefly pull the cruise control lever towards you ①.
- ▶ Remove your foot from the accelerator pedal.
The first time cruise control is activated, it stores the current speed or regulates the speed of the vehicle to the previously stored speed.

Setting a speed

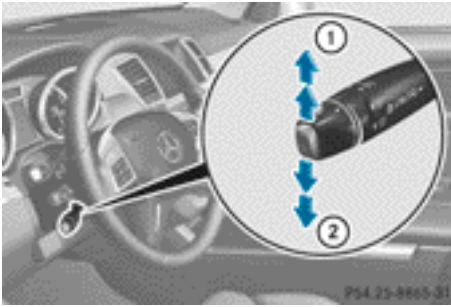

- ▶ Press the cruise control lever up ① for a higher speed or down ② for a lower speed.
 - ▶ Keep the cruise control lever pressed until the desired speed is reached.
 - ▶ Release the cruise control lever. The new speed is stored.
 - ▶ **Setting in 1-km/h increments:** press the cruise control lever up ① or down ② to the pressure point. The last speed stored is increased or reduced in 1 km/h increments.
 - ▶ **To adjust the set speed in 10-km/h increments:** press the cruise control lever briefly up ① or down ② beyond the pressure point. The last speed stored is increased or reduced in 10 km/h increments.
- i** Cruise control is not deactivated if you depress the accelerator pedal. For example, if you accelerate briefly to overtake, cruise control adjusts the vehicle's speed to the last speed stored after you have finished overtaking.

Deactivating cruise control

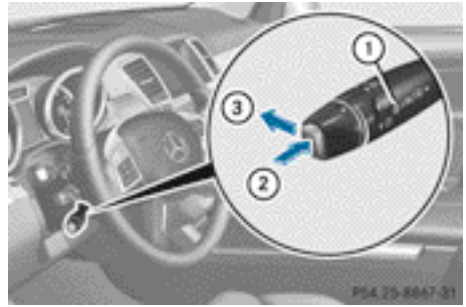

There are several ways to deactivate cruise control:

- ▶ Briefly press the cruise control lever forwards ③.
- or
- ▶ Brake
- or
- ▶ Briefly press the cruise control lever in the direction of arrow ②. Variable SPEEDTRONIC is selected. LIM indicator lamp ① in the cruise control lever lights up.

Cruise control is automatically deactivated if:

- you engage the electric parking brake.
- you are driving at less than 30 km/h.
- ESP® intervenes or you deactivate ESP®.
- you activate DSR.
- you activate off-road program 2 on vehicles with the ON&OFFROAD package.
- you shift the transmission to position **N** while driving.

If cruise control is deactivated, you will hear a warning tone. You will see the **Cruise control off** message in the multifunction display for approximately five seconds.

- i** The last speed stored is cleared when you switch off the engine.

SPEEDTRONIC

Important safety notes

WARNING

Never depress the brake pedal continuously while the vehicle is in motion, e.g. never cause the brakes to rub by applying constant slight pedal pressure. This causes the brake system to overheat, increases the braking distance and can lead to the brakes failing completely.

WARNING

Do not change down for additional engine braking on a slippery road surface. This could cause the drive wheels to lose their grip and the vehicle could skid.

WARNING

SPEEDTRONIC is only an aid designed to assist driving. You are responsible for the vehicle's speed and for braking in good time.

WARNING

If there is a change of drivers, advise the new driver of the limit speed stored.

Only use variable SPEEDTRONIC if you will not have to accelerate suddenly to a speed above that stored as the limit speed. You could otherwise cause an accident.

You can only exceed the limit speed stored if you deactivate variable SPEEDTRONIC:

- using the cruise control lever
- by depressing the accelerator pedal beyond the pressure point (kickdown)

It is not possible to deactivate variable SPEEDTRONIC by braking.

General notes

SPEEDTRONIC brakes automatically so that you do not exceed the set speed. On long and steep downhill gradients, especially if the vehicle is laden or towing a trailer, you must select shift range **1**, **2** or **3** in good time. By doing so, you will make use of the braking effect of the engine. This relieves the load on

the brake system and prevents the brakes from overheating and wearing too quickly. If you need additional braking, depress the brake pedal repeatedly rather than continuously.

You can set a variable or permanent limit speed:

- **variable** for speed limits, e.g. in built-up areas
- **permanent** for long-term speed restrictions, e.g. when driving with winter tyres fitted (▷ page 198)

 The speed indicated in the speedometer may differ slightly from the limit speed stored.

Variable SPEEDTRONIC

Cruise control lever

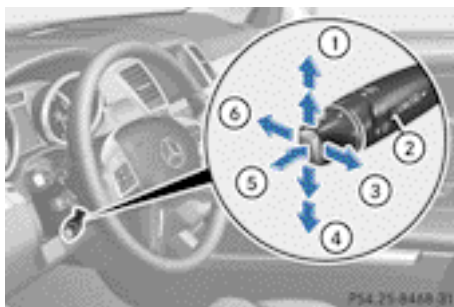

- ① To activate or increase speed
- ② LIM indicator lamp
- ③ To activate at the current speed/last stored speed
- ④ To activate or reduce speed
- ⑤ To switch between cruise control or DISTRONIC PLUS and variable SPEEDTRONIC
- ⑥ To deactivate variable SPEEDTRONIC

With the cruise control lever, you can operate cruise control or DISTRONIC PLUS and variable SPEEDTRONIC.

► **To switch between variable SPEEDTRONIC and cruise control/DISTRONIC PLUS:** press the cruise control lever in the direction of arrow ⑤.

LIM indicator lamp ② on the cruise control lever indicates which function you have selected:

- **LIM indicator lamp ② off:** cruise control or DISTRONIC PLUS is selected.
- **LIM indicator lamp ② on:** variable SPEEDTRONIC is selected.

You can use the cruise control lever to limit the speed to any speed above 30 km/h while the engine is running.

Storing the current speed

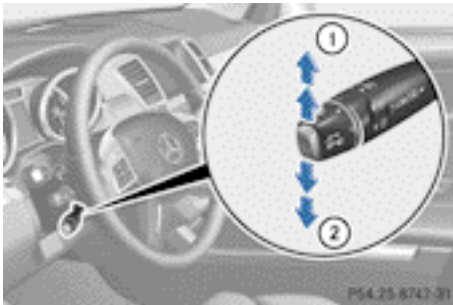

You can use the cruise control lever to limit the speed to any speed above 30 km/h while the engine is running.

- ▶ Briefly press the cruise control lever up ① or down ②.

The current speed is stored and shown in the multifunction display.

The segments in the multifunction display light up from the start of the scale up to the stored speed.

Storing the current speed and calling up the last stored speed

WARNING

Only select a stored speed if you know what that speed is and whether it is suitable for the current driving and traffic situation. Otherwise, sudden braking could endanger you or others.

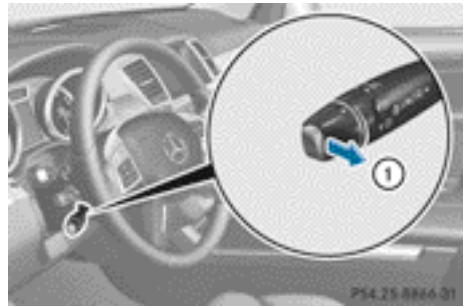

- ▶ Briefly pull the cruise control lever towards you ①.

Setting a speed

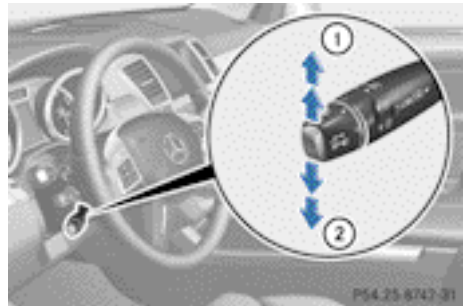

- ▶ **To adjust the set speed in 10 km/h increments:** briefly press the cruise control lever up ① past the pressure point for a higher speed, or down ② for a lower speed.

or

- ▶ Keep the cruise control lever pressed beyond the pressure point until the desired speed is set. Press the cruise control lever up ① for a higher speed or down ② for a lower speed.

- ▶ **To adjust the set speed in 1 km/h increments:** briefly press the cruise control lever up ① to the pressure point for a higher speed or down ② for a lower speed.

or

- ▶ Keep the cruise control lever pressed to the pressure point until the desired speed is set. Press the cruise control lever up ① for

a higher speed or down ② for a lower speed.

Deactivating variable SPEEDTRONIC

WARNING

It is not possible to deactivate variable Speedtronic by braking.

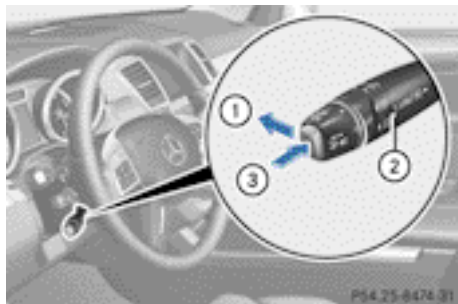

There are several ways to deactivate variable SPEEDTRONIC:

- ▶ Briefly press the cruise control lever forwards ①.

or

- ▶ Briefly press the cruise control lever in the direction of arrow ③.

LIM indicator lamp ② in the cruise control lever goes out. Variable SPEEDTRONIC is deactivated.

Cruise control or DISTRONIC PLUS is selected.

Variable SPEEDTRONIC is automatically deactivated if:

- you depress the accelerator pedal beyond the pressure point (kickdown), but only if your current speed does not differ by more than 20 km/h from the stored speed. You will hear a warning tone if this is the case.
- you activate DSR.
- you activate off-road program 2 (vehicles with the ON&OFFROAD package).

- i** The last speed stored is cleared when you switch off the engine.

Permanent SPEEDTRONIC

You can use the on-board computer to limit the speed permanently to a value between 160 km/h (e.g. for driving on winter tyres) and the maximum speed (▷ page 283).

Shortly before the stored speed is reached, it appears in the multifunction display.

Permanent SPEEDTRONIC remains active, even if variable SPEEDTRONIC is deactivated.

You cannot exceed the stored limit speed, even if you depress the accelerator pedal beyond the pressure point (kickdown).

DISTRONIC PLUS

Important safety notes

WARNING

Do not change down for additional engine braking on a slippery road surface. This could cause the drive wheels to lose their grip and the vehicle could skid.

WARNING

DISTRONIC PLUS is only an aid designed to assist driving. The driver remains fully responsible for the vehicle's distance from other vehicles, the vehicle's speed and for braking in good time.

DISTRONIC PLUS does not react in particular to:

- pedestrians
- stationary obstacles on the road, e.g. stopped or parked vehicles
- oncoming and crossing traffic

DISTRONIC PLUS may not detect narrow vehicles driving in front, e.g. motorcycles, or vehicles driving on a different line. Therefore, always pay attention to traffic conditions even when DISTRONIC PLUS is activated. Otherwise, you may fail to recognise dangers in time, cause an accident and injure yourself and others.

⚠ WARNING

DISTRONIC PLUS cannot take account of road and traffic conditions. If DISTRONIC does not recognise or no longer recognises the vehicle in front, do not activate DISTRONIC or, if it is already active, deactivate it. This is especially the case:

- before corners
- on filter lanes
- when changing to a lane with faster moving traffic
- in complex driving situations or where lanes are diverted, e.g. at roadworks on a motorway

DISTRONIC PLUS otherwise maintains the current speed set by you or accelerates up to the set speed.

DISTRONIC PLUS cannot take account of weather conditions. Deactivate, or do not activate, DISTRONIC PLUS:

- if the roads are slippery, snow-covered or icy. The wheels could lose their grip when braking or accelerating. The vehicle could start to skid.
- if the sensors are dirty or there is poor visibility, e.g. due to snow, rain or fog. Distance control may be impaired.

Always pay attention to traffic conditions even when DISTRONIC PLUS is activated. Otherwise, you may fail to recognise dangers in time, cause an accident and injure yourself and others.

⚠ WARNING

DISTRONIC PLUS brakes your vehicle up to a maximum of 4 m/s^2 depending on its speed. This corresponds to approximately 40% of your vehicle's maximum braking power. You must also apply the brakes yourself if this braking power is not sufficient.

If DISTRONIC PLUS detects a risk of collision with a vehicle in front, an intermittent warning tone sounds. In addition, the  distance warning lamp in the instrument cluster lights up. Brake to avoid a collision.

⚠ WARNING

The vehicle can be braked when DISTRONIC PLUS is activated. For this reason, deactivate DISTRONIC PLUS if the vehicle is to be set in motion by other means (e.g. in a car wash or by towing).

The radar sensor system is switched off automatically in the vicinity of radio telescope facilities (▷ page 433).

If you want DISTRONIC PLUS to assist you, the radar sensor system must be activated (▷ page 283) and operational.

General notes

DISTRONIC PLUS regulates the speed and automatically helps you maintain the distance to the vehicle detected in front. DISTRONIC PLUS brakes automatically so that the set speed is not exceeded.

On long and steep downhill gradients, especially if the vehicle is laden or towing a trailer, you must select shift range **1**, **2** or **3** in good time. By doing so, you will make use of the braking effect of the engine. This relieves the load on the brake system and prevents the brakes from overheating and wearing too quickly.

If DISTRONIC PLUS detects a slower-moving vehicle in front, your vehicle is braked in order to maintain the preset distance to the vehicle in front.

If there is no vehicle in front, DISTRONIC PLUS operates in the same way as cruise control in the speed range between 30 km/h and 200 km/h. If a vehicle is driving in front of you, DISTRONIC operates in the speed range between 0 km/h and 200 km/h.

Do not use DISTRONIC PLUS on roads with steep gradients.

Cruise control lever

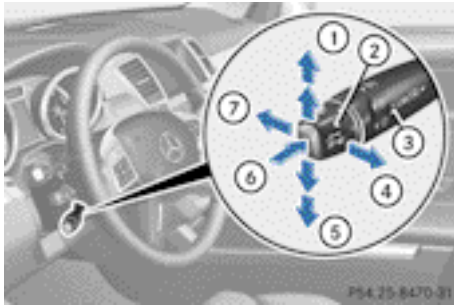

- ① To activate or increase speed
- ② To set the specified minimum distance
- ③ LIM indicator lamp
- ④ To activate at the current speed/last stored speed
- ⑤ To activate or reduce speed
- ⑥ To switch between DISTRONIC PLUS and variable SPEEDTRONIC
- ⑦ To deactivate DISTRONIC PLUS

With the cruise control lever, you can operate DISTRONIC PLUS and variable SPEEDTRONIC.

- ▶ **To switch between variable SPEEDTRONIC and DISTRONIC PLUS:** press the cruise control lever in the direction of arrow ⑥.

LIM indicator lamp ③ on the cruise control lever indicates which function you have selected:

- **LIM indicator lamp ③ off:** DISTRONIC PLUS is selected.
- **LIM indicator lamp ③ on:** variable SPEEDTRONIC is selected.

Activating DISTRONIC PLUS

Activation conditions

To activate DISTRONIC PLUS, the following conditions must be fulfilled:

- the engine must be running. It may take up to two minutes of driving before DISTRONIC PLUS is ready for use.
- the electric parking brake must be released.
- ESP® must be switched on, but not intervening.
- the transmission must be in position **D**.
- the driver's door must be closed when you shift from **P** to **D** or your seat belt must be fastened.
- the front-passenger door and the rear doors must be closed.
- Off-road program 2 must be deactivated (vehicles with the ON&OFFROAD package).
- DSR must be deactivated.
- the vehicle must not be skidding.
- the DISTRONIC PLUS function must be selected (> page 200).

Activating while driving

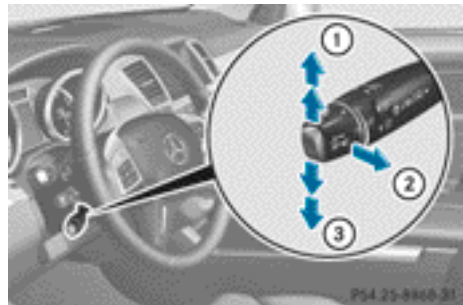

- ▶ Briefly pull the cruise control lever towards you ② or press it up ① or down ③. DISTRONIC PLUS is selected.
- ▶ Press the cruise control lever repeatedly up ① or down ③ until the desired speed is set.
- ▶ Remove your foot from the accelerator pedal.
Your vehicle adapts its speed to that of the vehicle in front, but only up to the desired stored speed.

If the vehicle in front has been detected and is shown in the multifunction display, you can also activate DISTRONIC PLUS when driving at speeds below 30 km/h. If the vehicle in front is no longer detected and displayed, for example because it has changed lanes, DISTRONIC PLUS is deactivated. You will hear a warning tone if this is the case.

- ❗ If you do not fully release the accelerator pedal, the **DISTRONIC PLUS inactive** message appears in the multifunction display. The set distance to a slower-moving vehicle in front will then not be maintained. You will be driving at the speed you determine by the position of the accelerator pedal.

Activating when driving towards a stationary vehicle

- ▶ Briefly pull the cruise control lever towards you ② or press it up ① or down ③. DISTRONIC PLUS is selected.
- ▶ Keep the cruise control lever pressed up ① or down ③ until the desired speed is set.

If the vehicle in front of you is stationary, you can only activate DISTRONIC PLUS once your vehicle is stationary as well.

- ❗ DISTRONIC PLUS can only be activated at under 30 km/h if a vehicle in front has been detected. Therefore, the DISTRONIC PLUS distance display in the instrument cluster should be activated (▷ page 277).

- ❗ You can use the cruise control lever to set the stored speed and the control on the cruise control lever to set the specified minimum distance (▷ page 204).

Activating at the current speed/last stored speed

⚠ WARNING

Only call up a stored speed if you know what that speed is and if it is suitable for the current traffic and driving situation. You can otherwise endanger yourself or others by unintentionally triggering sudden acceleration or braking.



- ▶ Briefly pull the cruise control lever towards you ①.
- ▶ Remove your foot from the accelerator pedal.
DISTRONIC PLUS is activated. The first time it is activated, the current speed is stored. Otherwise, it sets the vehicle cruise speed to the previously stored value.

Driving with DISTRONIC PLUS

Pulling away and driving

⚠ WARNING

If you depress the brake, DISTRONIC PLUS is deactivated unless your vehicle is stationary. DISTRONIC PLUS then no longer brakes your vehicle. In such cases, control the distance from vehicles travelling in front with the brake alone. You could otherwise cause an accident and thereby injure yourself and others. The driver remains fully responsible for the vehi-

cle's distance from other vehicles, the speed being driven and for braking in good time.

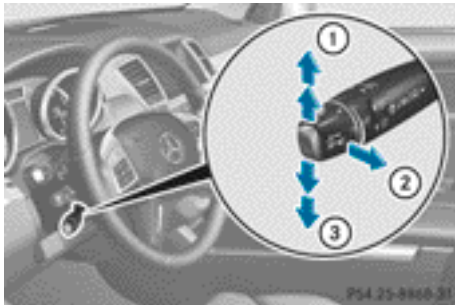

- ▶ **If the vehicle in front pulls away:** remove your foot from the brake pedal.
- ▶ Briefly pull the cruise control lever towards you ② or press it up ① or down ③.

or

- ▶ Accelerate briefly.
Your vehicle pulls away and adapts its speed to that of the vehicle in front.

If there is no vehicle in front, DISTRONIC PLUS operates in the same way as cruise control.

If DISTRONIC PLUS detects that the vehicle in front has slowed down, it brakes your vehicle. In this way, the distance you have selected is maintained.

If DISTRONIC PLUS detects a faster-moving vehicle in front, it increases the driving speed. However, the vehicle is only accelerated up to the speed you have stored.

Changing lanes

WARNING

DISTRONIC PLUS and Active Blind Spot Assist are only an aid designed to assist driving.

They do not relieve you of the responsibility of paying attention. The driver remains fully responsible for the vehicle's distance from other vehicles, the vehicle's speed and for braking in good time. Always pay attention to traffic conditions and your surroundings. Otherwise, you may fail to recognise dangers in

time, cause an accident and injure yourself and others.

If you change to the overtaking lane, DISTRONIC PLUS supports you if:

- you are driving faster than 60 km/h.
- DISTRONIC PLUS is maintaining the distance to a vehicle in front.
- you switch on the respective turn signals.
- DISTRONIC PLUS does not detect a danger of collision.

If these conditions are met, your vehicle is accelerated. Acceleration will be interrupted if changing lanes takes too long or if the distance between your vehicle and the vehicle in front becomes too small.

- i** When changing lanes, DISTRONIC PLUS monitors the left lane for left-hand-drive vehicles and the right lane for right-hand-drive vehicles.

Vehicles with COMAND Online

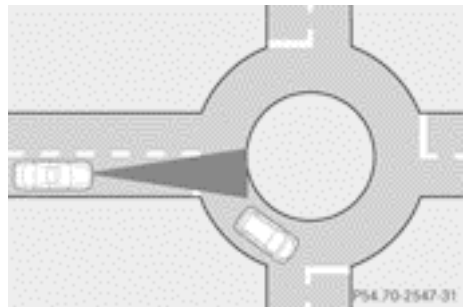

Example: roundabout

- i** The following function is not operational in all countries.

DISTRONIC PLUS uses additional information from your navigation system so that it can adapt to certain traffic situations. This is the case if, while following a vehicle, DISTRONIC PLUS is active and you:

- approach or drive around a roundabout
- approach a T-junction
- turn off at a motorway exit

Even if the vehicle in front leaves the detection range, DISTRONIC PLUS temporarily maintains the current driving speed and does not accelerate. This is based on the current map data in the navigation system.

The current speed is maintained:

- approximately 10 seconds before the roundabout/T-junction and approximately 1.5 seconds when driving on a roundabout.
- approximately 12 seconds before reaching a motorway exit and approximately 4 seconds after the motorway exit.

Afterwards, the vehicle accelerates back to the set speed you specified.

Stopping

WARNING

Never get out of the vehicle when DISTRONIC PLUS is activated.

DISTRONIC PLUS must also never be operated, activated or deactivated by a passenger or from outside the vehicle.

DISTRONIC PLUS does not replace the electric parking brake and must not be used for parking.

The DISTRONIC PLUS braking effect is cancelled and the vehicle can start moving if:

- DISTRONIC PLUS is deactivated using the cruise control lever.
- you accelerate.
- there is a malfunction in the system or an interruption in the power supply, e.g. battery failure.
- the electrical system in the engine compartment, the battery or the fuses are tampered with.
- the battery is disconnected.

If you wish to leave the vehicle or park it, deactivate DISTRONIC PLUS and secure the vehicle against rolling away.

If DISTRONIC PLUS detects that the vehicle in front is stopping, it brakes your vehicle until it is stationary.

Once your vehicle is stationary, it remains stationary and you do not need to depress the brake.

After a time, the electric parking brake secures the vehicle and relieves the service brake.

Depending on the specified minimum distance, your vehicle will come to a standstill at a sufficient distance behind the vehicle in front. The specified minimum distance is set using the control on the cruise control lever.

The electric parking brake secures the vehicle automatically if DISTRONIC PLUS is activated and:

- the driver's door is open and the driver's seat belt is unfastened.
- the engine is switched off, unless it is automatically switched off by the ECO start/stop function.
- a system fault occurs.
- the power supply is not sufficient.

On steep uphill or downhill inclines or if there is a malfunction, the transmission may also be automatically shifted into position **P**.

Setting a speed

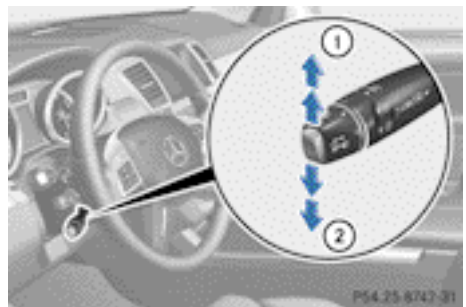

- ▶ Press the cruise control lever up ① for a higher speed or down ② for a lower speed.
- ▶ Keep the cruise control lever pressed until the desired speed is reached.
- ▶ Release the cruise control lever. The new speed is stored. DISTRONIC PLUS is activated and adjusts the vehicle's speed to the new speed stored.

► **To adjust the set speed in 1 km/h increments:** briefly press the cruise control lever up ① or down ② to the pressure point.

The last stored speed increases or decreases in 1 km/h increments.

► **To adjust the set speed in 10 km/h increments:** briefly press the cruise control lever up ① or down ② to beyond the pressure point.

The last stored speed increases or decreases in 10 km/h increments.

❗ DISTRONIC PLUS is not deactivated if you depress the accelerator pedal. If you accelerate to overtake, DISTRONIC PLUS adjusts the vehicle's speed to the last speed stored after you have finished overtaking.

Setting the specified minimum distance

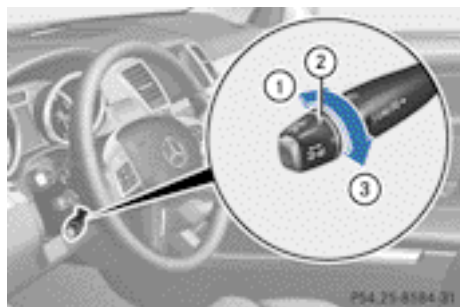

You can set the specified minimum distance for DISTRONIC PLUS by varying the time span between one and two seconds. With this function, you can set the minimum distance that DISTRONIC PLUS keeps to the vehicle in front, dependent on vehicle speed. You can see this distance in the multifunction display (▷ page 205).

► **To increase:** turn control ② in direction ③.

DISTRONIC PLUS then maintains a greater distance between your vehicle and the vehicle in front.

► **To decrease:** turn control ② in direction ①.

DISTRONIC PLUS then maintains a shorter distance between your vehicle and the vehicle in front.

❗ Make sure that you maintain a sufficient and safe distance from the vehicle in front. Adjust the distance to the vehicle in front if necessary.

Deactivating DISTRONIC PLUS

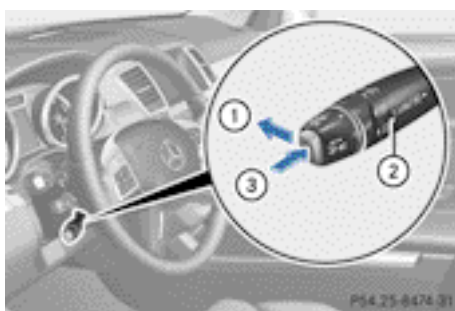

There are several ways to deactivate DISTRONIC PLUS:

► Briefly press the cruise control lever forwards ①.

or

► Brake, unless the vehicle is stationary.

or

► Briefly press the cruise control lever in the direction of arrow ③.

Variable SPEEDTRONIC is selected. LIM indicator lamp ② in the cruise control lever lights up.

When you deactivate DISTRONIC PLUS, you will see the **DISTRONIC PLUS off** message in the multifunction display for approximately five seconds.

- i** The last speed stored remains stored until you switch off the engine.
- i** DISTRONIC PLUS is not deactivated if you depress the accelerator pedal. If you accelerate to overtake, DISTRONIC PLUS adjusts the vehicle's speed to the last speed stored after you have finished overtaking.

DISTRONIC PLUS is automatically deactivated if:

- you engage the electric parking brake or if the vehicle is automatically secured with the electric parking brake.
- you are driving slower than 25 km/h and there is no vehicle in front, or if the vehicle in front is no longer detected.
- ESP[®] intervenes or you deactivate ESP[®].
- the transmission is in the **P**, **R** or **N** position.
- the vehicle is near a radio telescope facility (▷ page 433).
- you switch off the radar sensor system (▷ page 283).
- you pull the cruise control lever towards you in order to pull away, and the front-passenger door or one of the rear doors is open.
- you activate DSR.
- you activate off-road program 2 on vehicles with the ON&OFFROAD package.
- the vehicle has skidded.

If DISTRONIC PLUS is deactivated, you will hear a warning tone. You will see the **DISTRONIC PLUS off** message in the multifunction display for approximately five seconds.

Displays in the instrument cluster

Displays in the speedometer



Example: DISTRONIC PLUS displays in the speedometer

When DISTRONIC PLUS is activated, one or two segments ② in the set speed range light up.

If DISTRONIC PLUS detects a vehicle in front, segments ② between speed of the vehicle in front ① and stored speed ③ light up.

- i** For design reasons, the speed displayed in the speedometer may differ slightly from the speed set for DISTRONIC PLUS.

Display when DISTRONIC PLUS is deactivated



Distance display when DISTRONIC PLUS is deactivated

- ① Vehicle in front, if detected
- ② Distance indicator: current distance to the vehicle in front
- ③ Specified minimum distance to the vehicle in front; adjustable
- ④ Own vehicle

In the Assistance menu (▷ page 277) of the on-board computer, you can select the distance display.

- ▶ Select the **Distance display** function using the on-board computer .

In the Assistance menu of the on-board computer, you can also activate or deactivate PRE-SAFE® Brake (▷ page 278).

Display when DISTRONIC PLUS is activated

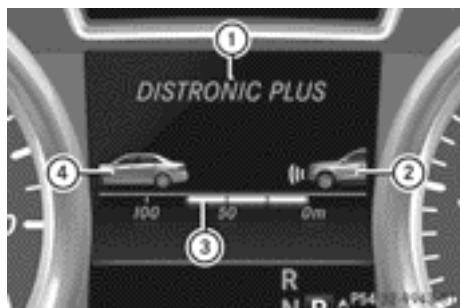

Distance display with DISTRONIC PLUS activated in the multifunction display

- ① DISTRONIC PLUS activated
- ② Own vehicle
- ③ Specified minimum distance to the vehicle in front; adjustable
- ④ Vehicle in front, if detected

In the Assistance menu (▷ page 277) of the on-board computer, you can select the distance display.

- ▶ Select the **Distance display** function using the on-board computer .

You will see the stored speed for about five seconds when you activate DISTRONIC PLUS.

Tips for driving with DISTRONIC PLUS

General notes

Pay particular attention in the following traffic situations:

- Cornering, going into and coming out of a bend
- Vehicles travelling on a different line

- Other vehicles changing lane
- Narrow vehicles
- Obstructions and stationary vehicles
- Crossing vehicles

In such situations, brake if necessary. DISTRONIC PLUS is then deactivated.

Cornering, going into and coming out of a bend

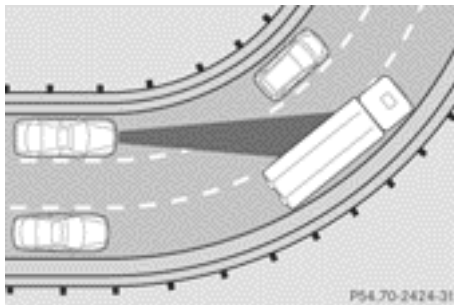

The ability of DISTRONIC PLUS to detect vehicles when cornering is limited. Your vehicle may brake unexpectedly or late.

Vehicles travelling on a different line

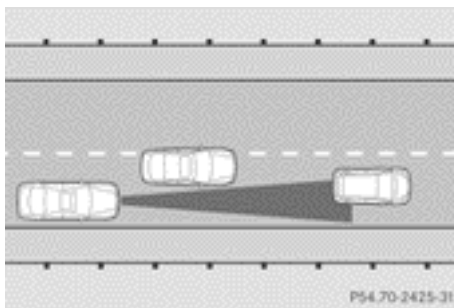

DISTRONIC PLUS may not detect vehicles travelling on a different line. The distance to the vehicle in front will be too short.

Other vehicles changing lane

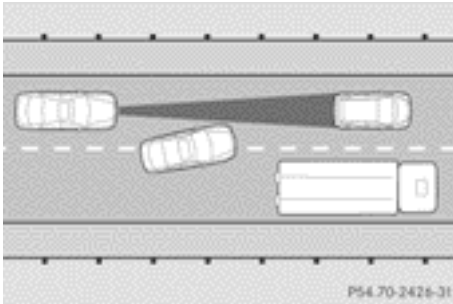

DISTRONIC PLUS has not detected the vehicle cutting in yet. The distance to this vehicle will be too short.

Narrow vehicles

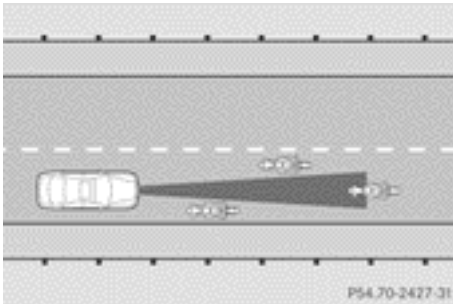

DISTRONIC PLUS has not yet detected the vehicle in front on the edge of the carriage-way, because of its narrow width. The distance to the vehicle in front will be too short.

Obstructions and stationary vehicles

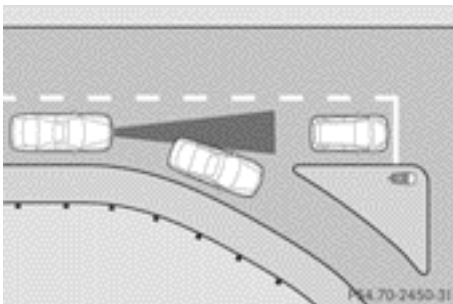

DISTRONIC PLUS does not brake for obstacles or stationary vehicles. If, for example, the

detected vehicle turns a corner and reveals an obstacle or stationary vehicle, DISTRONIC PLUS will not brake for these.

Crossing vehicles

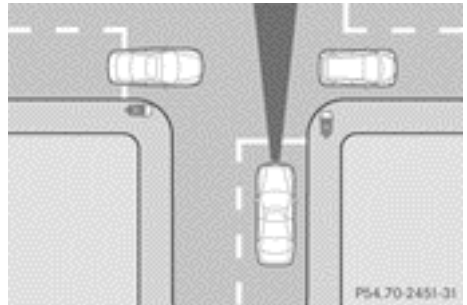

DISTRONIC PLUS may mistakenly detect vehicles that are crossing your lane. Activating DISTRONIC PLUS at traffic lights with crossing traffic, for example, could cause your vehicle to pull away unintentionally.

Level control (vehicles with the ON&OFFROAD package)

Important safety notes

WARNING

Make sure that nobody is near the wheel arch or vehicle underside when you make a change to the vehicle level. Otherwise, you or others may be trapped.

WARNING

Always select as low a vehicle level as possible. If the vehicle level is high, the vehicle centre of gravity shifts upwards. This increases the risk of the vehicle tipping over.

Adapt your driving style to suit the vehicle level. ESP[®] cannot reduce the risk of an accident if you drive too fast. ESP[®] cannot override the laws of physics.

-  When driving on extremely rough terrain, select a high vehicle level in good time. Make sure there is always sufficient ground

clearance. You will otherwise damage the vehicle.

Level control adapts the vehicle level automatically to the current operating and driving situation. This results in reduced fuel consumption and improved handling.

Make changes to the vehicle level while the vehicle is in motion. This enables the vehicle to adjust to the new level as quickly as possible.

The vehicle level may change visibly if you park the vehicle and the outside temperature changes. If the temperature drops, the vehicle level lowers; with an increase in temperature, the vehicle level rises.

If you unlock the vehicle or open a door, the vehicle begins to compensate for load discrepancies while still parked. However, for significant level changes, e.g. after the vehicle has been stationary for a long period, the engine must be running. For safety reasons, the vehicle is only lowered when the doors are closed. Lowering is interrupted if a door is opened; it continues once the door has been closed.

For information about driving off-road, see (> page 188).

Basic settings

The extent to which the vehicle is raised or lowered depends on the basic setting selected.

Select:

- Highway/high-speed level for driving on normal roads
- Off-road level 1 for driving on easily negotiable off-road terrain
- Off-road level 2 for driving on normal off-road terrain
- Off-road level 3 for freeing the vehicle from especially difficult off-road terrain at low speeds

The individual vehicle levels differ from highway level as follows:

- highway level: +/- 0 mm
- high-speed level: - 15 mm
- off-road level 1: 30 mm above highway level
- off-road level 2: 60 mm above highway level
- off-road level 3: 90 mm above highway level

Highway/high-speed level

! Make sure there is enough ground clearance when the vehicle is being lowered. It could otherwise hit the ground, damaging the underbody.

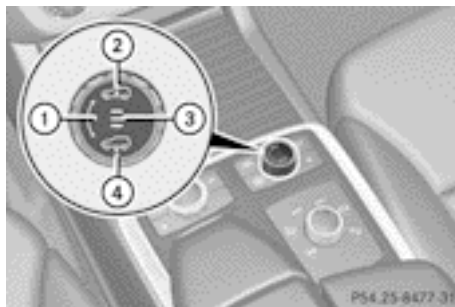

- ① Selector wheel
- ② To raise the level
- ③ Indicator lamps
- ④ To lower the level

▶ Start the engine.

▶ **Selector wheel ① engaged:** briefly press selector wheel ①. Selector wheel ① extends.



If one or more indicator lamps ③ are on:

▶ Turn selector wheel ① anti-clockwise ④ until all indicator lamps ③ that are lit start to flash.

The vehicle is lowered to highway level. As soon as the next lowest level is reached, the indicator lamp stops flashing and goes out.



During the adjustment, the **Lowering** message, for example, appears in the multifunction display.

If you press the  or **OK** button on the multifunction steering wheel, the message will disappear. Once highway level has been reached, all indicator lamps  go out.

The vehicle automatically selects highway level if you are driving at a speed above 115 km/h or if you drive at a speed between 100 km/h and 115 km/h for around 20 seconds. The vehicle is lowered to high-speed level if you are travelling at higher speeds.

Off-road levels

General notes

WARNING

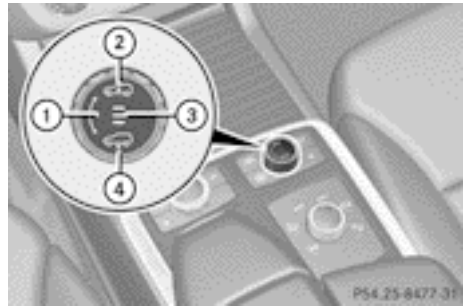

Off-road level 3 is not permitted for use on public roads. Off-road level 3 gives your vehicle a very high centre of gravity. This increases the risk of the vehicle tipping over.

- Only select off-road level 3 for driving off-road in particularly rough terrain.
- Adjust your driving style to the altered handling characteristics.
- Do not drive faster than 20 km/h.
- Avoid sudden major steering movements.
- Take account of the altered handling characteristics.





Only select an off-road level if this is appropriate for road conditions. Otherwise, fuel consumption may increase and handling performance may be affected.

► Start the engine.



► **Selector wheel  engaged:** briefly press selector wheel .

Selector wheel .

► **To raise:** turn selector wheel  clockwise .

The vehicle is raised.

or

► **To lower:** turn selector wheel  anti-clockwise .

The vehicle is lowered.

Indicator lamps  for the desired off-road level flash:



- Off-road level 1: the lower indicator lamp flashes.
- Off-road level 2: the lower and centre indicator lamps flash.
- Off-road level 3: all three indicator lamps flash.



The vehicle is being adjusted to the off-road level selected. As soon as an off-road level is reached, the corresponding indicator lamp stops flashing and lights up constantly.

Raising the vehicle

During the adjustment, the **Vehicle rising** message, for example, appears in the multifunction display.

The vehicle rises from highway level to off-road level 1.

If you press the  or  button on the multifunction steering wheel, the message will disappear.

- i** Up to off-road level 2, you can hide the messages using the  or  button on the multifunction steering wheel.

Once off-road level 2 has been reached, the lower and centre indicator lamps of the selector wheel are on.



While the adjustment from off-road level 2 to off-road level 3 is taking place, you will see a message such as the following in the multifunction display: **Vehicle rising Max. speed 20 km/h**.

The **Max. speed 20 km/h** message draws your attention to the maximum speed permitted for off-road level 3.

Once off-road level 3 has been reached, you will see a message shown in white in the multifunction display, for example: **Max. speed 20 km/h**.

If you drive above 20 km/h with off-road level 3, you will see the following message in red in the multifunction display: **Lowering Max. speed 20 km/h**.

- i** You cannot clear these messages.

You also hear a warning tone. The vehicle is lowered and off-road level 3 is cancelled.

If you continue to increase your speed, the red message continues to be shown in the multifunction display. The newly set level is not displayed until the vehicle has been set to a level suitable for the current speed.

Lowering the vehicle



If you maintain or reduce your speed, you will see a message in white in the display while the vehicle is being lowered, such as the following: **Lowering Max. speed 20 km/h**

The vehicle is lowered to off-road level 2.

If you select an off-road level when driving at too high a speed, the **Please reduce speed** message appears in the multifunction display.

You can select the following:

- Off-road level 1 at speeds up to 100 km/h
- Off-road level 2 at speeds up to 65 km/h
- Off-road level 3 at speeds up to 20 km/h

If you are driving above 80 km/h or drive between 65 km/h and 80 km/h for longer than 20 seconds, off-road level 2 will be cancelled. The vehicle is lowered to off-road level 1.

You will see a message in the multifunction display, for example: **Lowering**.

If you are driving above 115 km/h or drive at a speed between 100 km/h and 115 km/h for longer than 20 seconds, off-road level 1 will be cancelled. Depending on the vehicle's speed and the ADS mode selected (> page 212), the vehicle is automatically lowered to highway or high-speed level.

You will see a message in the multifunction display, for example: **Lowering**.

HOLD function

General notes

The HOLD function can assist the driver in the following situations:

- when pulling away, especially on steep slopes
- when manoeuvring on steep slopes
- when waiting in traffic

The vehicle is kept stationary without the driver having to depress the brake pedal.

The braking effect is cancelled and the HOLD function is deactivated when you depress the accelerator pedal to pull away.

- i Do not use the HOLD function when driving off-road, on steep downhill or uphill inclines or on a slippery or loose surface. Under such circumstances, the HOLD function may not be able to keep the vehicle stationary.

Activation conditions

You can activate the HOLD function if:

- the vehicle is stationary.
- the engine is running or if it has been automatically switched off by the ECO start/stop function.
- the driver's door is closed or if your seat belt is fastened.
- the electric parking brake is released.
- the transmission is in position **D**, **R** or **N**.
- DISTRONIC PLUS is deactivated.

Activating the HOLD function

⚠ WARNING

The vehicle's brakes are applied when the HOLD function is activated. For this reason, deactivate the HOLD function if the vehicle is to be set in motion by other means (e.g. in a car wash or by towing).

- ▶ Make sure that the activation conditions are met.
- ▶ Depress the brake pedal.
- ▶ Quickly depress the brake pedal further until **HOLD** appears in the multifunction display.
The HOLD function is activated. You can release the brake pedal.

- i If depressing the brake pedal the first time does not activate the HOLD function, wait briefly and then try again.

Deactivating the HOLD function

⚠ WARNING

Never get out of the vehicle when the HOLD function is activated.

The HOLD function must never be operated or deactivated by a passenger or from outside the vehicle.

The HOLD function does not replace the electric parking brake and must not be used for parking.

The braking effect of the HOLD function is cancelled and the vehicle could roll away if:

- the HOLD function is deactivated by depressing the accelerator pedal or the brake pedal.
- there is a malfunction in the system or an interruption in the power supply, e.g. battery failure.
- the electrical system in the engine compartment, the battery or the fuses are tampered with.
- the battery is disconnected.

If you leave the vehicle or park it, deactivate the HOLD function and secure the vehicle against rolling away.

The HOLD function is deactivated automatically if:

- you accelerate and the transmission is in position **D** or **R**.
- you shift the transmission to position **P**.

- you depress the brake pedal again with a certain amount of pressure until **HOLD** disappears from the multifunction display.
- you secure the vehicle using the electric parking brake.
- you activate DISTRONIC PLUS.

i After a time, the electric parking brake secures the vehicle and relieves the service brake.

The electric parking brake secures the vehicle automatically if the HOLD function is activated and:

- the driver's door is open and the driver's seat belt is unfastened.
- the engine is switched off, unless it is automatically switched off by the ECO start/stop function.
- a system fault occurs.
- the power supply is not sufficient.

On steep uphill or downhill inclines or if there is a malfunction, the transmission may also be automatically shifted into position **P**.

AIRMATIC package

General notes

AIRMATIC enables a suspension tuning setting to be selected and regulates the damping behaviour and level of your vehicle. The system comprises a minimum of two components. These are ADS (Adaptive Damping System) (▷ page 212) and level control (▷ page 213). Your vehicle may also be equipped with the Active Curve System (▷ page 213).

Observe the notes on driving with a trailer (▷ page 257).

ADS (Adaptive Damping System)

General notes

ADS adapts the damping characteristics to the current operating and driving situation.

This depends on:

- your driving style
- the road surface conditions
- the ADS setting
- the vehicle level setting

Your selection remains stored even if you remove the key from the ignition lock.

Sports tuning

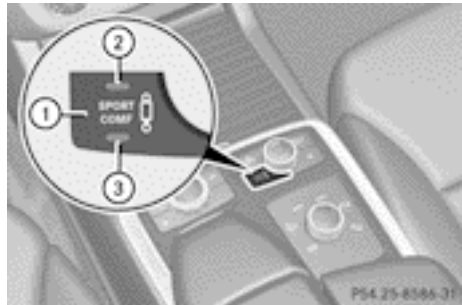

Example: vehicles with the ON&OFFROAD package

▶ Start the engine.

▶ Press button ①.

Indicator lamp ② lights up. You have selected "Sports tuning". The vehicle is lowered by 15 mm.

The firmer suspension tuning in Sport mode ensures even better contact with the road. Select this mode when employing a sporty driving style, e.g. on winding country roads.

Comfort tuning

▶ Press button ①.

Indicator lamp ③ lights up. You have selected "Comfort tuning". The vehicle is raised by 15 mm.

In comfort mode, the driving characteristics of your vehicle are more comfortable. Therefore, select this mode if you prefer a more comfortable driving style. Select comfort mode also when driving fast on straight roads, e.g. on straight stretches of motorway.

Active Curve System

The Active Curve System uses active stabilisers to optimise both driving comfort and vehicle agility. Depending on the ADS mode selected (▷ page 212), the Active Curve System also changes the setting.

If you select ADS comfort mode:

- rolling movement is reduced in the event of changing surface undulations.
- the roll angle when cornering is reduced.
- the driving style is agile.

If you select ADS sport mode:

- the roll angle is reduced significantly.
- the driving style is even more agile.

Level control

Important safety notes

WARNING

Make sure that nobody is near the wheel arch or vehicle underside when you make a change to the vehicle level. Otherwise, you or others may be trapped.

WARNING

Always select as low a vehicle level as possible. If the vehicle level is high, the vehicle centre of gravity shifts upwards. This increases the risk of the vehicle tipping over.

Adapt your driving style to suit the vehicle level. ESP® cannot reduce the risk of an accident if you drive too fast. ESP® cannot override the laws of physics.

- ❗ When driving on extremely rough terrain, select a high vehicle level in good time. Make sure there is always sufficient ground clearance. You will otherwise damage the vehicle.

General notes

Further information about "Driving off-road" (▷ page 188).

Level control adapts the vehicle level automatically to the current operating and driving

situation. This results in reduced fuel consumption and improved handling.

If you select ADS comfort mode (▷ page 212), the vehicle is lowered to high-speed level as the speed increases. As the vehicle decelerates, the vehicle is raised back up to highway level.

If you select ADS sport mode (▷ page 212), the vehicle skips highway level and lowers directly to high-speed level depending on the basic setting (▷ page 213).

Make changes to the vehicle level while the vehicle is in motion. This enables the vehicle to adjust to the new level as quickly as possible.

The vehicle level may change visibly if you park the vehicle and the outside temperature changes. If the temperature drops, the vehicle level lowers; with an increase in temperature, the vehicle level rises.

If you unlock the vehicle or open a door, the vehicle begins to compensate for load discrepancies while still parked. However, for significant level changes, e.g. after the vehicle has been stationary for a long period, the engine must be running. For safety reasons, the vehicle is only lowered when the doors are closed. Lowering is interrupted if a door is opened; it continues once the door has been closed.

Basic settings

The extent to which the vehicle is raised or lowered depends on the basic setting selected. Select raised level for off-road driving or highway/high-speed level for normal roads.

The individual vehicle levels differ from highway level as follows:

- highway level: +/- 0 mm
- high-speed level: -15 mm
- raised level: +60 mm

Raised level

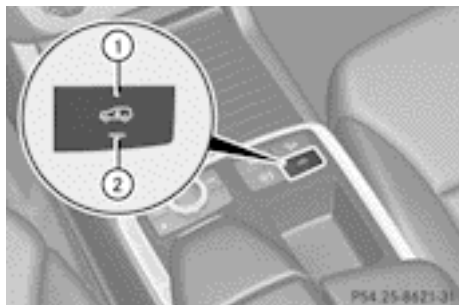

Example: vehicles without the ON&OFFROAD package

Only select raised level if this is appropriate for the road conditions. Otherwise, fuel consumption may increase and handling may be affected.

► Start the engine.



If indicator lamp ② is not lit:

► Press button ①.

Indicator lamp ② flashes. The vehicle rises to raised level.



During the adjustment, the **Vehicle rising** message, for example, appears in the multifunction display.

If you press the  or  button on the multifunction steering wheel, the message will disappear.

Once the vehicle has reached raised level, indicator lamp ② remains lit. The **Vehicle rising** message disappears from the multifunction display.

If you try to select raised level at a speed above 65 km/h, the **Please reduce speed** message appears.

Highway/high-speed level

! Make sure there is enough ground clearance when the vehicle is being lowered. It could otherwise hit the ground, damaging the underbody.

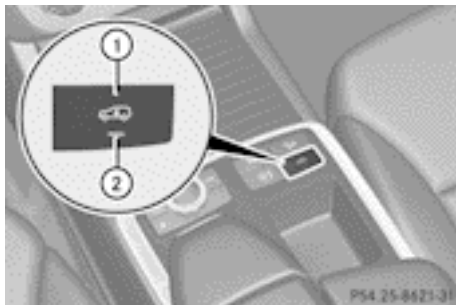

Example: vehicles without the ON&OFFROAD package

① Level control button

② Level control indicator lamp

► Start the engine.



If indicator lamp ② is lit:

► Press button ①.

Indicator lamp ② flashes. The vehicle is adjusting to highway/high-speed level.



During the adjustment, the **being lowered** message, for example, appears in the multifunction display.

If you press the  or  button on the multifunction steering wheel, the message will disappear.

Once highway level has been reached, indicator lamp  goes out. The **being lowered** message disappears from the multifunction display.

The vehicle automatically adjusts to highway level when you:

- drive faster than 80 km/h or
- drive at a speed between 65 km/h and 80 km/h for approximately 20 seconds.

Depending on the ADS setting selected (\triangleright page 212), the vehicle is lowered to high-speed level at high speeds.

AMG RIDE CONTROL sports suspension

Vehicle level

The vehicle automatically sets the vehicle level at the rear axle. Rear axle level control ensures the best possible suspension and that the ground clearance remains constant even when the vehicle is loaded. This improves driving safety and fuel consumption.

Suspension tuning

General notes

The electronically controlled damping system works continuously. This improves driving safety and ride comfort.

The damping is tuned individually to each wheel and depends on:

- your driving style, e.g. sporty
- the road surface condition, e.g. bumps
- your individual selection of Sport, Sport + or Comfort

If you select Sport or Sport + mode and restart the engine, the suspension setting reverts to Comfort mode.

Sport mode

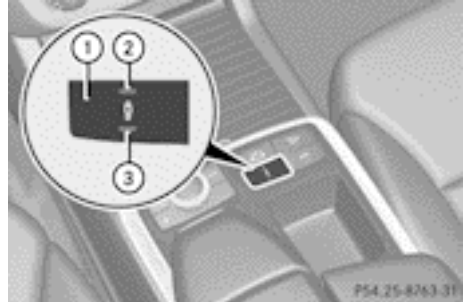

The firmer suspension tuning in Sport mode ensures even better contact with the road. Select this mode when employing a sporty driving style, e.g. on winding country roads.

- ▶ Press the  button once.

Indicator lamp  lights up. You have selected Sport mode.



The **AMG Ride Control SPORT** message appears in the multifunction display.

Sport + mode

The very firm setting of the suspension tuning in Sport + mode ensures the best possible contact with the road. Select this mode only when driving on race circuits.

If indicator lamps  and  are off:

- ▶ Press button  twice.

Indicator lamps  and  light up. You have selected Sport + mode.

The **AMG Ride Control SPORT +** message appears in the multifunction display.

If indicator lamp  lights up:

- ▶ Press the  button once.

Second indicator lamp  lights up. You have selected Sport + mode.

The **AMG Ride Control SPORT +** message appears in the multifunction display.

Comfort mode

In comfort mode, the driving characteristics of your vehicle are more comfortable. Therefore, select this mode if you prefer a more

comfortable driving style. Select comfort mode also when driving fast on straight roads, e.g. on straight stretches of motorway.

► Press button ① repeatedly until indicator lamps ③ and ② go out.

You have selected Comfort mode.

The **AMG Ride Control COMFORT** message appears in the multifunction display.

PARKTRONIC

Important safety notes

WARNING

PARKTRONIC is only an aid and may not detect all obstacles. It is not a substitute for attentive driving.

You are always responsible for safety and must continue to pay attention to your immediate surroundings when parking and manoeuvring. You could otherwise endanger yourself and others.

WARNING

Make sure that no persons or animals are in the manoeuvring range. Otherwise, they could be injured.

PARKTRONIC is an electronic parking aid with ultrasonic sensors. It indicates visually and audibly the distance between your vehicle and an object.

PARKTRONIC is activated automatically if you:

- switch on the ignition
- shift the transmission to position **D**, **R** or **N**
- release the electric parking brake

PARKTRONIC is deactivated at speeds above 18 km/h. It is reactivated at lower speeds.

PARKTRONIC monitors the area around your vehicle using six sensors in the front bumper and four sensors in the rear bumper.

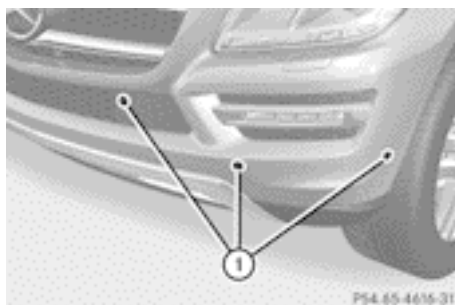

- ① Example: sensors in the front bumper, left-hand side

Range of the sensors

General notes

 When parking, pay particular attention to objects above or below the sensors, such as flower pots or trailer drawbars. PARKTRONIC does not detect such objects when they are in the immediate vicinity of the vehicle. You could damage the vehicle or the objects.

The sensors may not detect snow and objects which absorb ultrasonic sources.

Ultrasonic sources, such as an automatic car wash, a lorry's compressed-air brakes or a pneumatic drill, could cause PARKTRONIC to malfunction.

PARKTRONIC may not function correctly on uneven terrain.

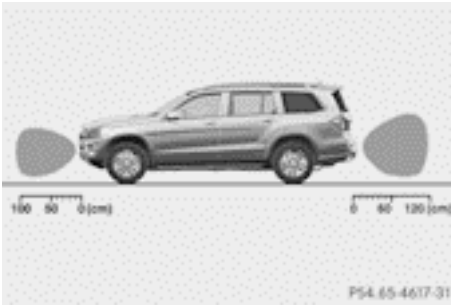

Side view

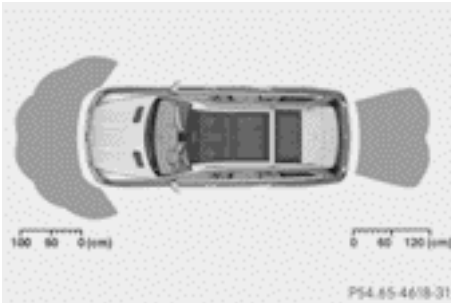

Top view

The sensors must be free of dirt, ice and slush. Otherwise, they may not function correctly. Clean the sensors regularly, taking care not to scratch or damage them (▷ page 370).

Front sensors

Centre	approximately 100 cm
Corners	approximately 60 cm

Rear sensors

Centre	approximately 120 cm
Corners	approximately 80 cm

Minimum distance

Centre	approximately 20 cm
Corners	approximately 15 cm

If there is an obstacle within this range, the relevant warning displays light up and a warning tone sounds. If the distance falls below

the minimum, the distance may no longer be shown.

Warning displays

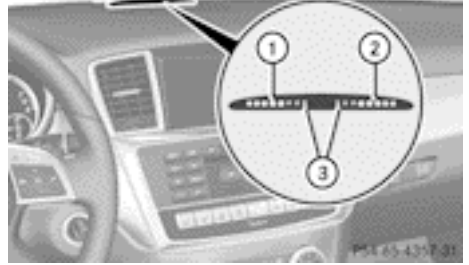

Warning display for the front area

- ① Segments on the left-hand side of the vehicle
- ② Segments on the right-hand side of the vehicle
- ③ Segments showing operational readiness

The warning displays show the distance between the sensors and the obstacle. The warning display for the front area is located on the dashboard above the centre air vents. The warning display for the rear area is in the roof lamp in the rear compartment.

The warning display for each side of the vehicle is divided into five yellow and two red segments. PARKTRONIC is operational if yellow segments showing operational readiness ③ light up.

The selected transmission position and the direction in which the vehicle is rolling determine which warning display is active when the engine is running.

Transmission position	Warning display
D	Front area activated
R, N or the vehicle is rolling backwards	Rear and front areas activated
P	No areas activated

One or more segments light up as the vehicle approaches an obstacle, depending on the vehicle's distance from the obstacle.

From the:

- sixth segment onwards, you will hear an intermittent warning tone for approximately two seconds.
- seventh segment onwards, you will hear a warning tone for approximately two seconds. This indicates that you have now reached the minimum distance.

Deactivating/activating PARKTRONIC

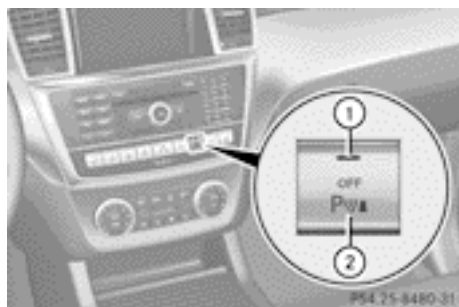

- ① Indicator lamp
- ② To deactivate/activate PARKTRONIC

If indicator lamp ① lights up, PARKTRONIC is deactivated. Active Park Assist is then also deactivated.

- i** PARKTRONIC is automatically activated when you turn the key to position **2** in the ignition lock.

Towing a trailer

! Fold in the ball coupling if the trailer tow hitch is not required. PARKTRONIC measures the minimum detection range to an obstacle from the bumper, not the ball coupling.

PARKTRONIC is deactivated for the rear area when you establish an electrical connection between your vehicle and a trailer.

Problems with PARKTRONIC

Problem	Possible causes/consequences and ► Solutions
<p>Only the red segments in the PARKTRONIC warning displays are lit. You also hear a warning tone for approximately two seconds.</p> <p>PARKTRONIC is deactivated after approximately five seconds, and the indicator lamp in the PARKTRONIC button lights up.</p>	<p>PARKTRONIC has malfunctioned and has switched off.</p> <ul style="list-style-type: none"> ► If problems persist, have PARKTRONIC checked at a qualified specialist workshop.
<p>Only the red segments in the PARKTRONIC warning displays are lit. PARKTRONIC is deactivated after approximately five seconds.</p>	<p>The PARKTRONIC sensors are dirty or there is interference.</p> <ul style="list-style-type: none"> ► Clean the PARKTRONIC sensors (▷ page 370). ► Switch the ignition back on. <p>The problem may be caused by an external source of radio or ultrasound waves.</p> <ul style="list-style-type: none"> ► See if PARKTRONIC functions in a different location.

Active Parking Assist

Important safety notes

WARNING

Active Parking Assist is merely an aid and may sometimes recommend parking spaces that are not suitable for parking. For example, these might be spaces where parking is prohibited, driveways, unsuitable surfaces, etc.

Active Parking Assist measures the parking space as you drive past it. Any later changes to the parking space are not taken into account. For instance, this may be the case when the vehicle parked in front of or behind the space changes its position or when an obstacle is moved into the parking space.

Active Parking Assist does not relieve you of the responsibility of paying attention. If you rely solely on Active Parking Assist, you could

cause an accident and injure yourself and others.

You are always responsible for safety and must continue to pay attention to your immediate surroundings when parking and manoeuvring.

WARNING

Objects located above the height range of Active Parking Assist will not be detected when the parking space is measured. These are not taken into account when the parking procedure is calculated, e.g. overhanging loads, tail sections or loading ramps of goods vehicles. In some circumstances, Active Parking Assist may therefore guide you into the parking space too early. This may lead to a collision. For this reason, you should avoid using Active Parking Assist in such situations.

⚠ WARNING

The front of the vehicle will veer out in the direction of the oncoming traffic during the parking operation. In some cases the vehicle will also take you onto sections of the oncoming lane during the parking procedure.

You are responsible for safety at all times and must pay attention to any road users approaching or passing. Stop the vehicle if necessary or cancel the Active Parking Assist parking procedure.

⚠ WARNING

Make sure that no persons or animals are in the manoeuvring range. Otherwise, they could be injured.

! If unavoidable, you should drive over obstacles such as kerbs slowly and not at a sharp angle. Otherwise, you may damage the wheels or tyres.

Active Parking Assist is an electronic parking aid with ultrasound. Ultrasound is used to measure the road on both sides of the vehicle. A suitable parking space is indicated by the parking symbol. Active steering intervention can assist you during parking. You may also use PARKTRONIC (▷ page 216). When PARKTRONIC is switched off, Active Parking Assist is also unavailable.

Use Active Parking Assist for parking spaces:

- that are parallel to the direction of travel
- that are on straight roads, not bends
- that are on the same level as the road, e.g. not on the pavement

Parking tips:

- on narrow roads, drive as closely as possible past the parking space.
- parking spaces that are littered, overgrown or partially occupied by trailer drawbars might be identified incorrectly or not at all.
- snowfall or heavy rain may lead to a parking space being measured inaccurately.

- pay attention to the PARKTRONIC (▷ page 217) warning messages during the parking procedure.
- at any time, you can intervene in the steering procedure to correct it. Active Parking Assist will then be cancelled.
- when transporting a load which protrudes from your vehicle, you should not use Active Parking Assist.
- when snow chains or an emergency spare wheel are fitted, you should not use Active Parking Assist here either.
- make sure that the tyre pressures are always correct. This has a direct influence on the parking characteristics of the vehicle.
- the way your vehicle is positioned in the parking space after parking is dependent on various factors. These include the position and shape of the vehicles parked in front and behind it and the conditions of the location. It may be the case that Active Parking Assist guides you too far into a parking space, or not far enough into it. In some cases, it may also lead you across or onto the kerb. If necessary, you should cancel the parking procedure with Active Parking Assist.
- you can also engage forward gear prematurely. The vehicle redirects and does not drive as far into the parking space. Should a gear be changed too early to achieve a sensible parking position, the parking procedure will be cancelled.

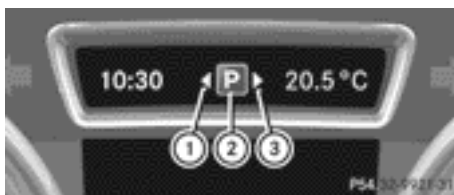
Detecting parking spaces

- ① Detected parking space on the left
- ② Parking symbol
- ③ Detected parking space on the right

Active Parking Assist is switched on automatically when driving forwards. The system is operational at speeds of up to approximately 35 km/h. While in operation, the system independently locates and measures parking spaces on both sides of the vehicle. When driving at speeds below 30 km/h, you will see the parking symbol as a status indicator in the instrument cluster. Active Parking Assist only displays parking spaces on the front-passenger side as standard. Parking spaces on the driver's side are displayed as soon as the turn signal on the driver's side is activated. To park on the driver's side, you must leave the driver's side turn signal switched on. This must remain switched on until you acknowledge the use of Active Parking Assist by pressing the  button on the multifunction steering wheel.

When a parking space has been detected, an arrow towards the right or the left also appears.

Active Parking Assist will only detect parking spaces:

- that are parallel to the direction of travel
- that are at least 1.5 m wide
- that are at least 1.3 m longer than your vehicle

A parking space is displayed while you are driving past it, and until you are approximately 15 m away from it.

Parking

WARNING



PARKTRONIC and Active Parking Assist are merely parking aids and may not detect all obstacles. They do not relieve you of the responsibility of paying attention.

You are always responsible for safety and must continue to pay attention to your immediate surroundings when parking and manoeuvring. You could, otherwise, endanger yourself and others.



WARNING

When parking, you need to make sure that no obstacles are located in the vicinity of the vehicle during the entire operation. Active Parking Assist does not relieve you of the responsibility of paying attention. It merely aids you by intervening actively in the steering.

To stop the vehicle or avoid an accident you need to apply the brakes yourself.

- ▶ Stop the vehicle when the parking space symbol shows the desired parking space in the instrument cluster.
- ▶ Shift the transmission to position **R**. The **Start Park Assist? Yes: OK No: ** message appears in the multifunction display.
- ▶ **To cancel the procedure:** press the  button on the multifunction steering wheel or pull away.

or

- ▶ **To park using Active Parking Assist:** press the  button on the multifunction steering wheel. The **Park Assist active Accelerate and brake Observe surroundings** message appears in the multifunction display.
- ▶ Release the multifunction steering wheel.
- ▶ Reverse the vehicle, being ready to brake at all times. When reversing, drive at a speed below 10 km/h. Otherwise, Active Parking Assist will be cancelled.
- ▶  In tight parking spaces, you will achieve the best parking results by backing up as far as possible. When doing so, also observe the PARKTRONIC messages.
- ▶ Stop as soon as PARKTRONIC sounds the continuous warning tone, if not before. Manoeuvring may be required in tight parking spaces.

The **Park Assist active Select D Observe surroundings** message appears in the multifunction display.

- ▶ Shift the transmission to position **D** while the vehicle is stationary.

Active Parking Assist immediately steers in the other direction.

The **Park Assist active Accelerate and brake Observe surroundings** message appears in the multifunction display.

- i** You will achieve the best results by waiting for the steering procedure to complete before pulling away.

- ▶ Drive forwards and be ready to brake at all times.
- ▶ Stop as soon as PARKTRONIC sounds the continuous warning tone, if not before.

The **Park Assist active Select R Observe surroundings** message appears in the multifunction display.

Further transmission shifts may be necessary.

As soon as the parking procedure is complete, the **Park Assist switched off** message appears in the multifunction display. PARKTRONIC is still available.

- ▶ Manoeuvre if necessary.
- ▶ Always observe the warning messages displayed by PARKTRONIC (▷ page 217).

Parking tips:

- on narrow roads, drive as closely as possible past the parking space.
- parking spaces that are littered, overgrown or partially occupied by trailer drawbars might be identified incorrectly or not at all.
- snowfall or heavy rain may lead to a parking space being measured inaccurately.
- the way your vehicle is positioned in the parking space after parking is dependent on various factors. These include the position and shape of the vehicles parked in front and behind it and the conditions of the location. In some cases, Active Parking Assist may guide you too far into a parking space, or not far enough into it. In some cases, it may also lead you across or onto the kerb. If necessary, you should cancel

the parking procedure with Active Parking Assist.

- you can also engage forward gear prematurely. The vehicle redirects and does not drive as far into the parking space. Should a gear be changed too early, the parking procedure will be cancelled. A sensible parking position can no longer be achieved from this position.



Exiting a parking space

WARNING

Active Parking Assist does not monitor street traffic. In some cases, the vehicle will also take you onto sections of the oncoming lane when exiting a parking space.

You are responsible for safety at all times and must pay attention to any road users approaching or passing. Stop the vehicle if necessary or cancel Active Parking Assist.

Active Parking Assist can only assist you with exiting a parking space if you have parked the vehicle using Active Parking Assist.

- ▶ Start the engine.
- ▶ Switch on the turn signal on the side facing the street.
- ▶ Shift the transmission to position **D** or **R**. The **Start Park Assist? Yes: OK No: ** message appears in the multifunction display.
- ▶ **To cancel the procedure:** press the **** button on the multifunction steering wheel or pull away.

or

- ▶ **To exit a parking space using Active Parking Assist:** press the **** button on the multifunction steering wheel. The **Park Assist active Accelerate and brake Observe surroundings** message appears in the multifunction display.
- ▶ Release the multifunction steering wheel.
- ▶ Reverse the vehicle or drive forwards, being ready to brake at all times. Do not exceed a maximum speed of approximately

10 km/h when exiting a parking space. Otherwise, Active Parking Assist will be cancelled.

- ▶ Stop as soon as PARKTRONIC sounds the continuous warning tone, if not before.
- ▶ Shift the transmission to position **D** or **R** as required while the vehicle is stationary. Active Parking Assist immediately steers in the other direction.

i You will achieve the best results by waiting for the steering procedure to complete before pulling away.

If you reverse after activation, the steering wheel is moved to the straight-ahead position.

- ▶ Drive forwards or reverse the vehicle, being ready to brake at all times.
- ▶ Stop as soon as PARKTRONIC sounds the continuous warning tone, if not before.
- ▶ Drive forwards and reverse as instructed by the PARKTRONIC warning displays.

Once you have exited the parking space completely, the steering wheel is moved to the straight-ahead position. You hear a tone and the message **Park Assist switched off** appears in the multifunction display. You will then have to steer and merge into traffic on your own. PARKTRONIC is still available.

Cancelling Active Parking Assist

- ▶ Stop the movement of the multifunction steering wheel or steer yourself. Active Parking Assist will be cancelled at once. The **Park Assist cancelled** message appears in the multifunction display.

or

- ▶ Press the PARKTRONIC button on the centre console (▷ page 218). PARKTRONIC is switched off and Active Parking Assist is immediately cancelled. The **Park Assist cancelled** message appears in the multifunction display.

Active Parking Assist is cancelled automatically if:

- parking using Active Parking Assist is no longer possible.
- you are driving faster than 10 km/h.
- a wheel spins and ESP[®] intervenes or fails. The  warning lamp lights up in the instrument cluster.

A warning tone sounds. The parking symbol disappears and the multifunction display shows the **Park Assist cancelled** message.

When Active Parking Assist is cancelled, you must steer again yourself.

Towing a trailer

For vehicles with a trailer tow hitch, the minimum length for parking spaces is slightly increased.

If you have attached a trailer to your vehicle, you should not use Active Parking Assist. Once the electrical connection is established between your vehicle and the trailer, Active Parking Assist is no longer available. PARKTRONIC is deactivated for the rear area.

Reversing camera

Important safety notes

WARNING

Make sure that no persons or animals are in the manoeuvring range. Otherwise, they could be injured.

WARNING

The reversing camera is only an aid and may show a distorted view of obstacles, show them incorrectly or not at all. The reversing camera is not a substitute for paying attention. The camera cannot show objects in the following areas:

- very close to the rear bumper
- under the rear bumper
- in close range above the handle on the boot lid

You are always responsible for safety, and must always pay attention to your surroundings when parking and manoeuvring. This applies to the areas behind, in front of and beside the vehicle. You could otherwise endanger yourself and others.

WARNING

Under the following circumstances, the reversing camera will not function, or will function in a limited manner:

- if the boot lid is open
- in heavy rain, snow or fog
- at night or in very dark places
- if the camera is exposed to very bright light
- if the area is lit by fluorescent light or LED lighting (the display may flicker)
- if there is a sudden change in temperature, e.g. when driving into a heated garage in winter
- if the camera lens is dirty or obstructed
- if the rear of your vehicle is damaged. In this event, have the camera position and setting checked at a qualified specialist workshop.

Do not use the reversing camera in these types of situation. You could otherwise injure others or damage objects and your vehicle while you are parking.

General notes



Reversing camera ① is in the handle on the tailgate.

Reversing camera ① is an optical parking and manoeuvring aid. It shows the area behind your vehicle with guide lines in the COMAND display.

The area behind the vehicle is displayed as a mirror image, as in the rear-view mirror.

-  The text of messages shown in the COMAND display depends on the language setting. The following are examples of reversing camera messages in the COMAND display.

Activating/deactivating the reversing camera

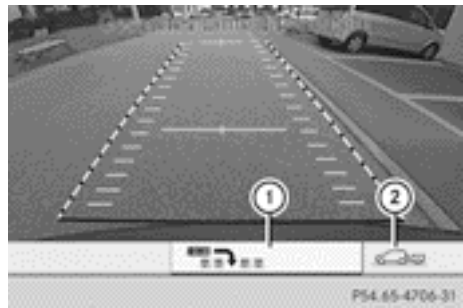

- ▶ **To activate:** make sure that the key is in position 2 in the ignition lock.
- ▶ Make sure that the function show reversing camera display is selected in COMAND Online.
- ▶ Engage reverse gear.
The area behind the vehicle is shown with guide lines in the COMAND display.
- ▶ **To change the function mode for vehicles with trailer tow hitch:** using the COMAND controller, select symbol ① for the "Reverse parking" function or symbol ② for "Coupling up a trailer" (see the separate COMAND Online operating instructions).
The symbol of the selected function is highlighted.

To deactivate: the reversing camera is deactivated if you:

- shift the transmission to position **P**
- drive forwards 10 m
- shift the transmission from **R** to another position (after 15 seconds)
- drive forwards at a speed of over 10 km/h

Displays in the COMAND display

WARNING

Using the reversing camera can be dangerous if you are colour-blind or if your ability to distinguish colours is impaired.

Only use the reversing camera if you can see and distinguish between all the coloured guide lines that are displayed by the reversing camera in the COMAND display.

WARNING

Please note that objects not at ground level may appear to be further away than they actually are. These include:

- the bumper of a vehicle that is parked behind your vehicle
- a trailer drawbar
- the ball coupling of a trailer tow hitch
- the tail-end of a lorry
- slanted posts

The lines are only guides, not accurate measurements of the distance to an obstacle.

Therefore, you should never pass the red line when approaching an obstacle. You could otherwise cause an accident and injure yourself and others.

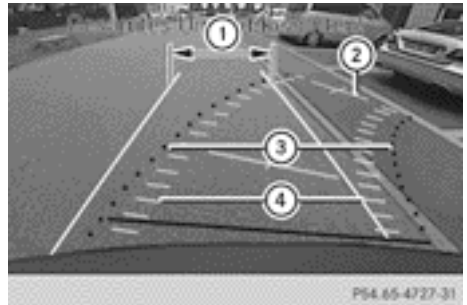

- ① White guide line without turning the steering wheel, vehicle width including the exterior mirrors (static)
- ② Yellow guide line at a distance of approximately 4.0 m from the rear of the vehicle
- ③ Red guide line for the vehicle width including the exterior mirrors, for current steering wheel angle (dynamic)
- ④ Yellow lane marking the course the tyres will take at the current steering wheel angle (dynamic)

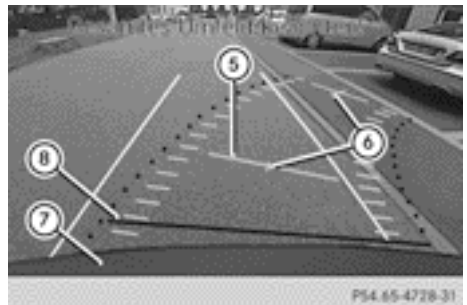

- ⑤ Yellow guide line at a distance of approximately 1.0 m from the rear of the vehicle
- ⑥ Vehicle centre axle (marker assistance)
- ⑦ Bumper
- ⑧ Red guide line at a distance of approximately 0.25 m from the rear of the vehicle

The guide lines are shown when the transmission is in position **R**.

The distance specifications only apply to objects that are at ground level.

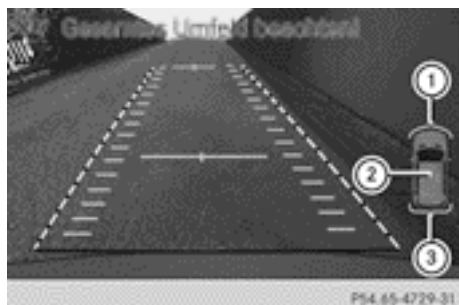

Additional messages for vehicles with PARKTRONIC

- ① Front warning display
- ② Additional PARKTRONIC operational readiness indicator
- ③ Rear warning display

Vehicles with PARKTRONIC: when PARKTRONIC is operational (▷ page 217), the additional operational readiness indicator ② appears in the COMAND Display. If the PARKTRONIC warning displays are active or light up, then the ①③ warning displays are also active or light up correspondingly in the COMAND display.

Reverse parking function

Reversing straight into a parking space without turning the steering wheel



- ① White guide line without turning the steering wheel, vehicle width including the exterior mirrors (static)
- ② Red guide line for the vehicle width including the exterior mirrors, for current steering wheel angle (dynamic)

- ③ Yellow guide line at a distance of approximately 1.0 m from the rear of the vehicle
- ④ Red guide line at a distance of approximately 0.25 m from the rear of the vehicle

- ▶ Make sure that the reversing camera is switched on (▷ page 224). The lane and the guide lines are shown.
- ▶ With the help of white guide line ①, check whether the vehicle will fit into the parking space.
- ▶ Using white guide line ① as a guide, carefully reverse until you reach the end position. Red guide line ④ is then at the end of the parking space. The vehicle is almost parallel in the parking space.

Reverse perpendicular parking with the steering wheel at an angle



Turning the steering wheel

- ① Red guide line for the vehicle width including the exterior mirrors, for current steering wheel angle (dynamic)
- ② Parking space marking
- ▶ Make sure that the reversing camera is switched on (▷ page 224). The lane and the guide lines are shown.
- ▶ Drive past the parking space and bring the vehicle to a standstill.
- ▶ While the vehicle is at a standstill, turn the steering wheel in the direction of the park-

ing space until red guide line ① reaches parking space marking ②.

- ▶ Keep the steering wheel in that position and reverse carefully.



Reversing with the steering wheel turned

- ① Red guide line for the vehicle width including the exterior mirrors, for current steering wheel angle (dynamic)

- ▶ Stop the vehicle when it is almost exactly in front of the parking space. The white lane should be as close to parallel with the parking space marking as possible.



Driving to the final position

- ① White guide line at current steering wheel angle
- ② Parking space marking
- ▶ Turn the steering wheel to the centre position while the vehicle is stationary.

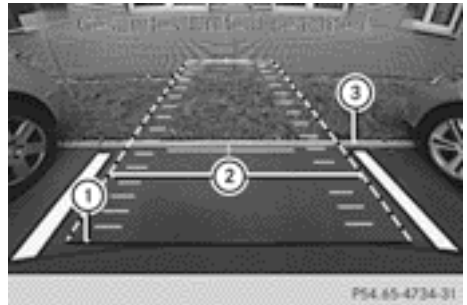

- ① Red guide line at a distance of approximately 0.25 m from the rear of the vehicle
- ② White guide line without turning the steering wheel
- ③ End of parking space

- ▶ Reverse carefully until you have reached the end position. Red guide line ① is then at the end of parking space ③. The vehicle is almost parallel in the parking space.

"Coupling up a trailer" function

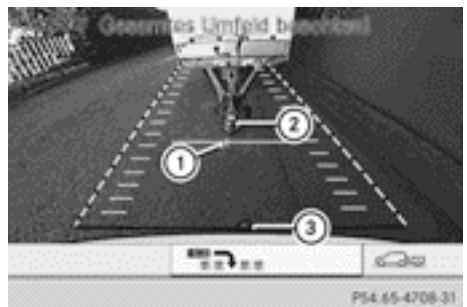

- ① Vehicle centre point on the yellow guide line at a distance of approximately 1.0 m from the rear of the vehicle
- ② Trailer drawbar
- ③ Ball coupling

This function is only available on vehicles with a trailer tow hitch.

- ▶ Set the height of trailer drawbar ② so that it is slightly higher than ball coupling ③.
- ▶ Position the vehicle centrally in front of trailer drawbar ②.

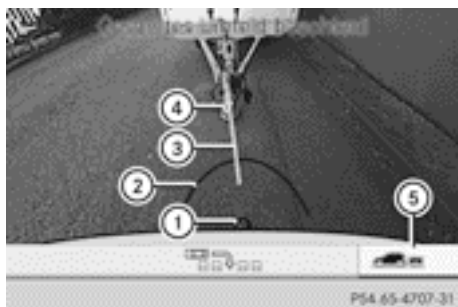

- ① Ball coupling
 - ② Red guide line at a distance of approximately 0.25 m from the ball coupling
 - ③ Trailer drawbar marker assistant
 - ④ Trailer drawbar
 - ⑤ Symbol for the "Coupling up a trailer" function
- ▶ Use the COMAND controller to select symbol ⑤, see the separate operating instructions for COMAND Online. The "Coupling up a trailer" function is selected. The distance specifications now only apply to objects that are at the same level as the ball coupling.
 - ▶ Reverse carefully, making sure that trailer drawbar marker assistant ③ points approximately in the direction of trailer drawbar ④.
 - ▶ Reverse carefully until the trailer drawbar ④ reaches red guide line ②.
 - ▶ Couple up the trailer (▶ page 257).

360° camera (surround view)

Important safety notes

WARNING

Make sure that no persons or animals are in the manoeuvring range. Otherwise, they could be injured.

The 360° camera is only an aid and may show a distorted view of obstacles, show them incorrectly or not at all. The 360° camera is

not a substitute for attentive driving. It cannot show objects in the following areas:

- under the front bumper
- very close to the front bumper
- very close to the rear bumper
- under the rear bumper
- in close range above the handle on the boot lid
- very close to the exterior mirrors

You are always responsible for safety, and must always pay attention to your surroundings when parking and manoeuvring. This applies to the areas behind, in front of and beside the vehicle. You could otherwise endanger yourself and others.

The reversing camera will not function or will function in a limited manner:

- if the doors are open
- if the exterior mirrors are folded in
- if the boot lid is open
- in heavy rain, snow or fog
- at night or in very dark places
- if the cameras are exposed to very bright light
- if the area is lit by fluorescent light or LED lighting (the display may flicker)
- if you exit a heated garage in winter, resulting in a rapid change in temperature
- if the camera lenses are dirty or covered
- if the vehicle components in which the cameras are fitted are damaged. In this event, have the camera position and setting checked at a qualified specialist workshop.

Do not use the 360° camera in this case. You can otherwise injure others or cause damage to objects or the vehicle.

General notes

The 360° camera is a system consisting of four cameras.

The system evaluates images from the following cameras:

- reversing camera
- front camera
- two cameras in the exterior rear view mirrors

The cameras capture the immediate surroundings of the vehicle. The system supports you, e.g. when parking or if vision is restricted at an exit.

The 360° camera images can be shown in full screen mode or in seven different split-screen views on the COMAND display. A split-screen view also includes a top view of the vehicle. This view is calculated from the data supplied by the installed cameras (virtual camera).

The 7 split-screen views are:

- top view and picture from the reversing camera (130° viewing angle)
- top view and picture from the front camera (without displaying the maximum steering wheel angle)
- top view and enlarged rear view
- top view and enlarged front view
- top view and trailer view (vehicles with trailer tow hitch)
- top view and pictures from the rearward facing mirror cameras (rear wheel view)
- top view and pictures from the forward facing mirror cameras (front wheel view)

i The top view and trailer view are available for vehicles equipped with a trailer tow hitch.

When the function is active and you shift the transmission from position **D** or **R** to **N**, you see the previous view in the COMAND display. The dynamic guidelines are hidden.

When you change between transmission positions **D** and **R**, you see the previously selected front or rear view.

Activation conditions

The 360° camera image can be displayed if:

- your vehicle is equipped with the 360° camera.
- COMAND Online is switched on, see the separate COMAND Online operating instructions.
- the **360° camera** function is activated

Activating the 360° camera using the SYS button

- ▶ Press and hold the **[sys]** button for longer than 2 seconds, see the separate COMAND Online operating instructions. Depending on whether position **D** or **R** is engaged, the following is shown:
 - full screen display with the image from the front camera
 - full screen display with the image from the rear camera.

Activating the 360° camera with COMAND Online

- ▶ Press the **[sys]** button, see the separate COMAND Online operating instructions.
- ▶ Select **System** by turning **[⊙]** the COMAND controller and press **[↻]** to confirm.
- ▶ Select **360° camera** and press **[↻]** to confirm. Depending on whether position **D** or **R** is engaged, the following is shown:
 - a split screen with top view and the image from the front camera or
 - a split screen with top view and the image from the reversing camera.

For further information about the COMAND Controller, see the separate COMAND Online operating instructions.

Activating the 360° camera using reverse gear

You can show images from the 360° camera automatically by engaging reverse gear.

- ▶ Make sure that the key is in position **2** in the ignition lock.
- ▶ Make sure that the **Activation by R gear** setting is active in COMAND Online, see the separate COMAND Online operating instructions.

- ▶ **To show the 360° camera image:** engage reverse gear.



The COMAND display shows the area behind the vehicle in Split Screen:

- vehicle with guide lines
- top view of the vehicle

Selecting the split-screen and full screen displays

- ▶ **To switch between split-screen views:** switch to the line with the vehicle symbols by sliding **↑**  the COMAND controller.

- ▶ Turn  the COMAND controller and select one of the vehicle symbols.

- ▶ **To switch to full screen mode:** select **Full screen** by turning  the COMAND controller and press  to confirm.

Displays in the COMAND display

Important safety notes

! Objects not at ground level may appear to be further away than they actually are, e.g.:

- the bumper of a parked vehicle
- the drawbar of a trailer
- the ball coupling of a trailer tow hitch
- the rear section of an HGV
- a slanted post

Use the guidelines only for orientation.

Approach objects no further than the bottom-most guideline.

Top view with picture from the rear view camera

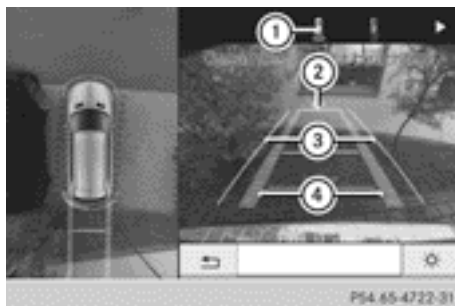

- ① Symbol for the split screen setting with top view and reversing camera image
- ② Yellow guide line at a distance of approximately 4.0 m from the rear of the vehicle
- ③ Yellow guide line for the vehicle width including the exterior mirrors, for current steering wheel angle (dynamic)
- ④ Yellow lane marking the course the tyres will take at the current steering wheel angle (dynamic)

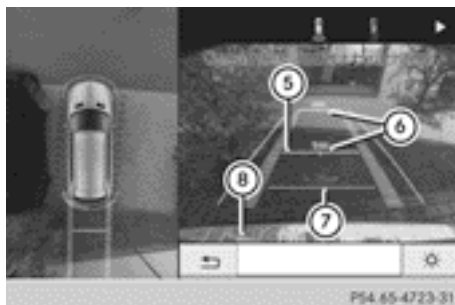

- ⑤ Yellow guide line at a distance of approximately 1.0 m from the rear of the vehicle
- ⑥ Vehicle centre axle (marker assistance)
- ⑦ Red guide line at a distance of approximately 0.30 m from the rear of the vehicle
- ⑧ Bumper

The guide lines are shown when the transmission is in position **R**.

The distance specifications only apply to objects that are at ground level.

Top view with picture from the front camera

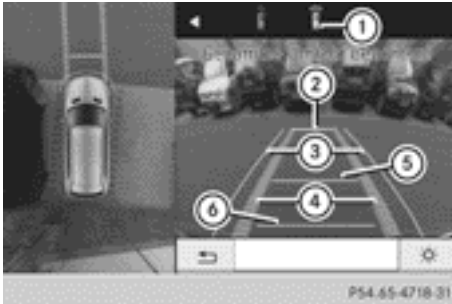

- ① Symbol for the split screen setting with top view and front camera image
- ② Yellow guide line at a distance of approximately 4.0 m from the front of the vehicle
- ③ Yellow guide line for the vehicle width including the exterior mirrors, for current steering wheel angle (dynamic)
- ④ Yellow lane marking the course the tyres will take at the current steering wheel angle (dynamic)
- ⑤ Yellow guide line at a distance of approximately 1.0 m from the front of the vehicle
- ⑥ Red guide line at a distance of approximately 0.30 m from the front of the vehicle

Top view and enlarged rear view

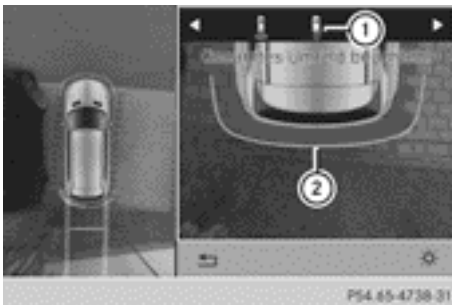

- ① Symbol for the split screen setting with top view and reversing camera image enlarged
- ② Red guide line at a distance of approximately 0.30 m from the rear of the vehicle

This view assists you in estimating the distance to the vehicle behind you.

- ⓘ This setting can also be selected as an enlarged front view.

Top view with picture from the mirror camera

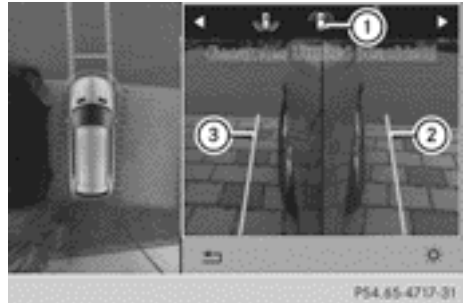

- ① Symbol for the top view and forward-facing mirror camera setting
- ② Yellow guide line for the vehicle width through the exterior mirror (right side of vehicle)
- ③ Yellow guide line for the vehicle width through the exterior mirror (left side of vehicle)

Top view with trailer view

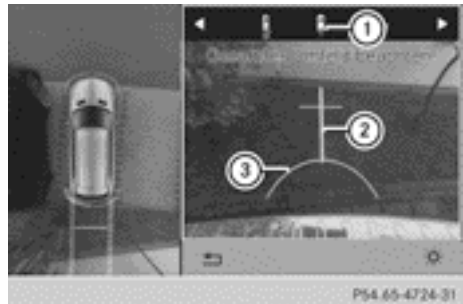

- ① Symbol for the trailer view setting
- ② Trailer drawbar marker assistant
- ③ Red guide line at a distance of approximately 0.30 m from the ball coupling

Display with the PARKTRONIC display



Example: full screen mode with PARKTRONIC display

① Symbol for the full screen setting with reversing camera image



If the vehicle is equipped with PARKTRONIC and the function is active (> page 218), warning displays ② in the COMAND Display are also active or light up accordingly.

PARKTRONIC appears:

- in split-screen view as red or yellow brackets around the vehicle symbol in the top view, or
- in the full screen view, on the right-hand side at the bottom as red or yellow brackets around the vehicle symbol.

i The full screen display can also be selected as front view.

Exiting 360° camera display mode

When the function is active and the vehicle exceeds the speed of 30 km/h, the function is deactivated. The COMAND display switches back to the previously selected view. You can also switch the display by selecting the  symbol in the display and pressing the COMAND controller .

ATTENTION ASSIST

Important safety notes

WARNING

ATTENTION ASSIST is only an aid and may detect your tiredness or lapses in concentration too late or not at all. It is not a substitute for a well rested and attentive driver.

Fatigue may cause you to recognise hazardous situations too late, misjudge a situation or react slower. For this reason, make sure you feel rested before you begin driving and during your journey. Always take breaks in good time and regularly, especially during long journeys. Otherwise, you may fail to recognise dangers in time, cause an accident and injure yourself and others.

ATTENTION ASSIST helps you during long, monotonous journeys such as on motorways and trunk roads. It is active in the 80 km/h to 180 km/h range.

If ATTENTION ASSIST detects typical indicators of fatigue or increasing lapses in concentration on the part of the driver, it suggests taking a break.

ATTENTION ASSIST assesses your level of fatigue or lapses in concentration by taking the following criteria into account:

- your personal driving style, e.g. steering characteristics
- journey-related parameters, e.g. time of day, length of journey



The functionality of ATTENTION ASSIST is restricted, and warnings may be delayed or not occur at all:

- if the road condition is poor, e.g. if the surface is uneven or if there are potholes
- if there is a strong side wind
- if you have adopted a sporty driving style with high cornering speeds or high rates of acceleration
- if you are predominantly driving slower than 80 km/h or faster than 180 km/h

- if you are currently using COMAND Online or making a telephone call with it
- if the time has been set incorrectly
- in active driving situations, such as when you change lanes or change your speed

Warning and display messages in the multifunction display



- ▶ Activate ATTENTION ASSIST using the on-board computer (▷ page 278). Symbol  appears in the multifunction display.
- ▶ **The Attention Assist: Take a break! message appears in the multifunction display.** If necessary, take a break.
- ▶ Press the  or  button to confirm the message.

If ATTENTION ASSIST is active, you will be warned no sooner than 20 minutes after your journey has begun. In addition to the message shown in the multifunction display, you will then hear an intermittent warning tone twice.

On long journeys, take regular breaks in good time to allow yourself to rest properly. If you do not take a break and ATTENTION ASSIST still detects increasing lapses in concentration, you will be warned again after 15 minutes at the earliest.

ATTENTION ASSIST is reset and starts assessing your tiredness again when you continue your journey if:

- you switch off the engine.
- you take off your seat belt and open the driver's door, e.g. for a change of drivers or to take a break.

Speed Limit Assist

Important safety notes

WARNING

Speed Limit Assist is only an aid and may detect speed limit signs incorrectly or not at all.

The system may be impaired or may not function if:

- there is poor visibility, e.g. due to snow, rain, fog or spray.
- there is glare, e.g. from the sun or from oncoming traffic.
- the windscreen is dirty, misted up or covered, for instance by a sticker, in the vicinity of the camera.
- the traffic signs are covered, for instance by dirt, snow or trees.
- the traffic signs are poorly illuminated.
- there are ambiguous traffic signs, for instance near roadworks or on multi-lane roads.

Traffic signs always have priority over the Speed Limit Assist display. Speed Limit Assist cannot detect road and traffic conditions. It is not a substitute for attentive driving.

Always pay attention to traffic conditions and your surroundings. Otherwise, you may fail to recognise dangers in time, cause an accident and injure yourself and others.

General notes

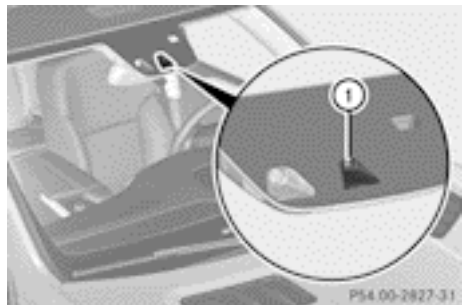

Speed Limit Assist detects the traffic signs with camera ① attached at the top of the windscreen.

- ① Speed Limit Assist is not operational in all countries.

Speed Limit Assist shows you detected speed limits in the multifunction display. Data from the navigation system is also used for this purpose. The display appears if Speed Limit Assist detects a traffic sign indicating a speed limit or the end of a speed limit. If Speed Limit Assist does not detect any traffic signs, the speed limit from the digital road map is taken and shown in the display.

Information in the multifunction display

Briefly showing detected traffic signs

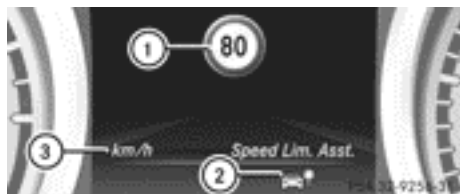

Example: multifunction display

- ① Traffic sign indicating a speed limit or the end of a speed limit
 - ② Speed Limit Assist is available and the warning function is switched on in the on-board computer
 - ③ Units used in the traffic sign displayed
- Activate the Speed Limit Assist warning function using the on-board computer (▷ page 277).
Symbol ② appears.

When you activate the Speed Limit Assist warning function, a traffic sign indicating the speed limit or end of speed limit zone ① may appear in the multifunction display. The traffic sign appears for approximately five seconds as soon as it is detected. Any other information in the multifunction display is hidden for this period.

Permanently showing detected traffic signs

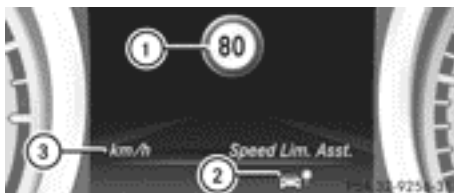

- ① Traffic sign indicating a speed limit or the end of a speed limit
 - ② Speed Limit Assist is available and the warning function is switched on in the on-board computer
 - ③ Units used in the traffic sign displayed
- Display Speed Limit Assist using the on-board computer (▷ page 277).

If Speed Limit Assist is selected in the on-board computer, a traffic sign indicating the speed limit or end of a speed limit zone ① appears in the multifunction display as soon as it is detected.

Traffic sign indicating a speed limit ① is generally displayed until:

- a traffic sign indicating the end of the speed limit is detected.
- you make a turn.
- you leave or enter a town.
- the road type changes (e.g. motorway, country road).
- you have travelled a certain minimum distance without the traffic sign being repeated or detected again.

Night View Assist Plus

Important safety notes

⚠ WARNING

Night View Assist Plus is only an aid designed to assist driving and does not relieve you of the responsibility to pay attention. Continue to look through the windscreen instead of relying on the Night View Assist Plus display.

You are responsible for safety and must drive in accordance with traffic conditions. You could otherwise endanger yourself and others.

The system may be impaired or may not function if:

- there is poor visibility, e.g. due to snow, rain, fog or spray.
- the windscreen is dirty, misted up or covered, for instance by a sticker, in the vicinity of the camera.
- on bends, on uphill gradients or downhill gradients.

WARNING

Night View Assist Plus is only an aid designed to assist driving and does not relieve you of the responsibility to pay attention. Continue to look through the windscreen instead of relying on the Night View Assist Plus display. You are responsible for safety and must drive in accordance with traffic conditions. You could otherwise endanger yourself and others.

The system may be impaired or may not function if:

- there is poor visibility, e.g. due to snow, rain, fog or spray.
- the windscreen is dirty, misted up or covered, for instance by a sticker, in the vicinity of the camera.
- on bends, on uphill gradients or downhill gradients.

General notes

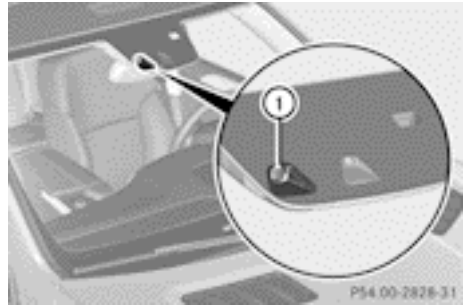

In addition to the illumination provided by the normal headlamps, Night View Assist Plus uses infrared light to illuminate the road. Night View Assist Plus camera ① picks up the infrared light and displays a monochrome image in COMAND. The image displayed in COMAND corresponds to a road lit up by main-beam headlamps. This enables you to see the road's course and any obstacles in good time. When pedestrian recognition is active, pedestrians recognised by the system are highlighted in the Night View Assist Plus display.

Light from the headlamps of oncoming vehicles does not affect the Night View Assist Plus display in the multifunction display. This is also the case if you cannot switch on the main-beam headlamps due to oncoming traffic.

-  Infrared light is not visible to the human eye and therefore does not dazzle. Night View Assist Plus can therefore remain switched on even if there is oncoming traffic.

Activating Night View Assist Plus

Activation conditions

You can only activate Night View Assist Plus if:

- the key is in position **2** in the ignition lock.
- it is dark.

- the light switch is in the **AUTO** or  position.
- reverse gear has not been engaged.

Activating Night View Assist Plus



- ▶ Make sure that COMAND APS is switched on.
 - ▶ Press button ①.
- The Night View Assist Plus display appears in the COMAND display.

You can read about how to adjust the brightness of the COMAND display in the COMAND Online operating instructions.

- ❗ The infrared headlamps only switch on when the vehicle is being driven at speeds of at least 10 km/h. This means that you do not have the full visual range while stationary and cannot check whether Night View Assist Plus is working.

Pedestrian recognition

WARNING

Pedestrian recognition may be impaired or inoperative if:

- pedestrians are partially or entirely obscured by objects, e.g. by parked vehicles.
- the silhouette of the pedestrian in the Night View Assist Plus display is incomplete or interrupted, e.g. by powerful light reflections.

- pedestrians do not contrast with the surroundings.
- pedestrians are not in an upright position, e.g. sitting, squatting or lying.

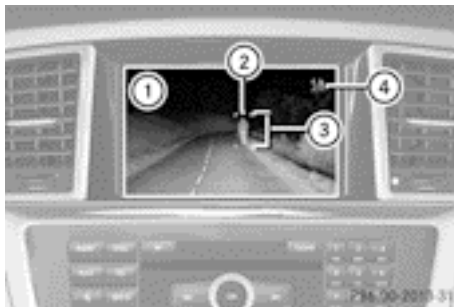

- ① Night View Assist Plus display
 - ② Pedestrian recognised
 - ③ Framing
 - ④ Symbol for active pedestrian recognition
- ❗ Animals are not recognised by pedestrian recognition.

Night View Assist Plus can recognise pedestrians using typical characteristics, e.g. when there is a silhouette in the shape of a person. Pedestrian recognition is then switched on automatically if:

- Night View Assist Plus is activated.
- you exceed a speed of approximately 10 km/h.
- the surroundings are dark, e.g. when driving outside built-up areas without street lighting.

If pedestrian recognition is active, symbol ④ appears. If a pedestrian is now recognised, they are framed ③ and thereby highlighted. If the pedestrian recognition system has brought a pedestrian to your attention, look through the windscreen to evaluate the situation. The actual distance to objects and pedestrians cannot be gauged accurately by looking at a screen.

It may be the case that objects are highlighted as well as pedestrians.

Misted up or dirty windscreen

If the windscreen in front of the camera is misted up or dirty on the inside or outside, the Night View Assist Plus display is affected.

- ▶ **To demist:** check the automatic air conditioning settings (▷ page 145) and fold down the camera cover (▷ page 371).
- ▶ **To demist the inside of the windscreen:** fold down the camera cover (▷ page 371) and clean the windscreen (▷ page 369).

Problems with Night View Assist Plus

Problem	Possible causes/consequences and ► Solutions
The picture quality of Night View Assist Plus has deteriorated.	The windscreen wipers are smearing the windscreen. ► Replace the wiper blades (▷ page 132).
	The windscreen is smeared after the vehicle has been cleaned in a car wash. ► Clean the windscreen (▷ page 369).
	There is windscreen chip damage in the camera's field of vision. ► Replace the windscreen.
	The windscreen is misted up on the inside. ► Demist the windscreen (▷ page 145).
	The windscreen is iced up. ► De-ice the windscreen (▷ page 145).
	There is dirt on the inside of the windscreen. ► Clean the inside of the windscreen (▷ page 369).

Lane Tracking package

General notes

The Lane Tracking package consists of Blind Spot Assist (▷ page 238) and Lane Keeping Assist (▷ page 240).

Blind Spot Assist

Important safety notes

WARNING

Blind Spot Assist is only an aid designed to assist driving. It may fail to detect some vehicles and is no substitute for attentive driving.

Blind Spot Assist cannot detect road and traffic conditions. It may fail to detect narrow vehicles, such as motorcycles or bicycles, or only detect them too late.

Monitoring may be affected by dirty sensors, strong spray or poor visibility caused by snow, rain or mist, for example. In this case, vehicles are detected late or not at all.

Always pay attention to traffic conditions and your surroundings. Otherwise, you may fail to recognise dangers in time, cause an accident and injure yourself and others.

WARNING

Blind Spot Assist is not active at speeds below 30 km/h. The indicator lamps in the exterior mirrors are yellow. Vehicles in the monitoring range are then not indicated.

Always pay attention to traffic conditions and your surroundings. Otherwise, you may fail to recognise dangers in time, cause an accident and injure yourself and others.

General notes

Blind Spot Assist uses a radar sensor system to monitor the areas on both sides of your vehicle. It supports you from speeds of 30 km/h. A warning display in the exterior mirrors draws your attention to vehicles detected in the monitored area. If you then switch on the corresponding turn signal to

change lane, you will also receive an optical and audible collision warning. For monitoring, Active Blind Spot Assist uses sensors in the rear bumper.

For Blind Spot Assist to assist you when driving, the radar sensor system must be activated (▷ page 283) and operational.

The radar sensor system is switched off automatically in the vicinity of radio telescope facilities (▷ page 433).

Monitoring range of the sensors

WARNING

Blind Spot Assist monitors certain areas in the immediate vicinity of your vehicle. Vehicles that approach and drive past at high speeds are not detected. There is no display and no warning.

If the lanes are very wide, it may not be possible to monitor the complete width of the neighbouring lane. For this reason, vehicles in the next lane may not be detected, especially if they are driving in a staggered formation in different lanes. This may be the case if vehicles are driving at the edge of their lane that is furthest away from your vehicle.

Always pay attention to traffic conditions and your surroundings. Otherwise, you may fail to recognise dangers in time, cause an accident and injure yourself and others.

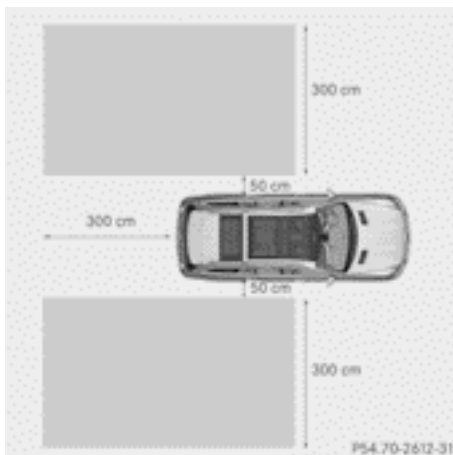

Blind Spot Assist monitors the area up to 3.0 m behind your vehicle and directly next to your vehicle, as shown in the diagram.

If the lanes are narrow, vehicles driving in the lane beyond the lane next to your vehicle may be indicated, especially if the vehicles are not driving in the middle of their lane. This may be the case if there are vehicles at the edge of their lane nearest your vehicle.

Due to the nature of the system:

- warnings may be issued in error when driving close to crash barriers or similar solid lane borders.
- warnings may be interrupted when driving alongside long vehicles, for example lorries, for a prolonged time.

The two radar sensors for Blind Spot Assist are integrated into the sides of the rear bumper. Make sure that the bumper is free of dirt, ice or slush in the vicinity of the sensors. The sensors must not be covered, for example by cycle racks or overhanging loads. Following a severe impact or in the event of damage to the bumpers, have the function of the sensors checked at a qualified specialist workshop. Blind Spot Assist may otherwise not work properly.

Indicator and warning display

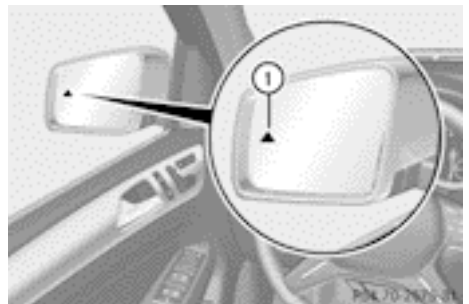

- ① Yellow indicator lamp/red warning lamp

If Blind Spot Assist is switched on, indicator lamp ① in the exterior mirrors lights up yellow up to a speed of 30 km/h. At speeds above 30 km/h, the indicator lamp goes out and Blind Spot Assist is operational.

If a vehicle is detected within the monitoring range of Blind Spot Assist at speeds above 30 km/h, warning lamp ① on the corresponding side lights up red. This warning always occurs when a vehicle enters the blind spot monitoring range from behind or from the side. When you overtake a vehicle, the warning only occurs if the difference in speed is less than 12 km/h.

The yellow indicator lamp goes out if reverse gear is engaged. Blind Spot Assist is then deactivated.

The brightness of the indicator/warning lamps is adjusted automatically according to the ambient light.

Collision warning

If a vehicle is detected in the monitoring range of Blind Spot Assist and you switch on the corresponding turn signal, a double warning tone sounds. Red warning lamp ① flashes. If the turn signal remains on, detected vehicles are indicated by the flashing of red warning lamp ①. There are no further warning tones.

Switching on Blind Spot Assist

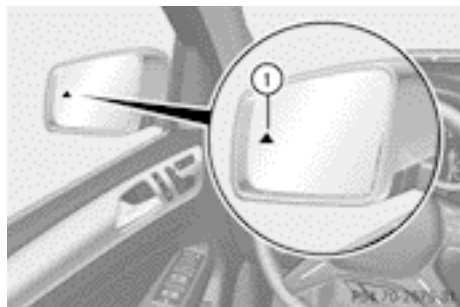

- ▶ Make sure that the radar sensor system (▷ page 283) and Blind Spot Assist (▷ page 279) are activated in the on-board computer.
- ▶ Turn the key to position **2** in the ignition lock.
Warning lamps ① in the exterior mirrors light up red for approximately 1.5 seconds and then turn yellow.

Towing a trailer

If you attach a trailer, make sure that you have correctly established the electrical connection. This can be accomplished by checking the trailer lighting. Blind Spot Assist is then deactivated. The indicator lamp in the exterior mirrors lights up yellow, and the **Blind Spot Assist currently unavailable See Owner's Manual** message appears in the multifunction display.

i You can deactivate the indicator lamps in the exterior mirrors.

To do so, switch off Blind Spot Assist if:

- the key is in position **2** in the ignition lock.
- the engine is not running.
- the electrical connection to the trailer has been established.

Lane Keeping Assist

Important safety notes

WARNING

Lane Keeping Assist does not keep your vehicle in its lane. It is only an aid and may detect the lane markings on the road incorrectly or not at all.

The system may be impaired or may not function if:

- there is poor visibility, e.g. due to insufficient illumination of the road, or due to snow, rain, fog or spray.
- there is glare, e.g. from oncoming traffic, the sun, or reflection from other vehicles.
- the windscreen is dirty, misted up or covered, for instance by a sticker, in the vicinity of the camera
- several or no lane markings for a single lane are present.
- the lane markings are worn away, dark or covered up, e.g. by dirt or snow.
- the distance to the vehicle in front is too small and the lane markings thus cannot be detected.

- the lane markings on the road are unclear, e.g. near roadworks.
- the lane markings change quickly, e.g. lanes branch off, cross one another or merge.
- the road is narrow and winding.

Lane Keeping Assist cannot detect road and traffic conditions. It is not a substitute for attentive driving. You are responsible for the vehicle's speed, braking in good time, and steering correctly. Always adapt your driving style to suit the prevailing road and weather conditions. Always pay attention to traffic conditions and your surroundings. Otherwise, you may fail to recognise dangers in time, cause an accident and injure yourself and others.

General notes

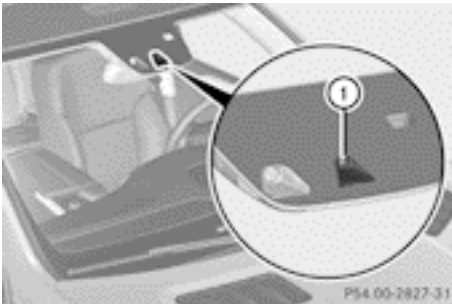

① Lane Keeping Assist camera

Lane Keeping Assist monitors the area in front of your vehicle by means of a camera at the top of the windscreen. Lane Keeping Assist detects lane markings on the road and warns you before you leave your lane unintentionally.

If you select **km** on the on-board computer in the **Display unit Speed-/odometer** function (▷ page 280), Lane Keeping Assist is active starting at a speed of 60 km/h. If the **miles** display unit is selected, the assistance range begins at 40 mph.

A warning may be given if a front wheel passes over a lane marking. It will warn you

by means of intermittent vibration in the steering wheel for up to 1.5 seconds.

Activating Lane Keeping Assist

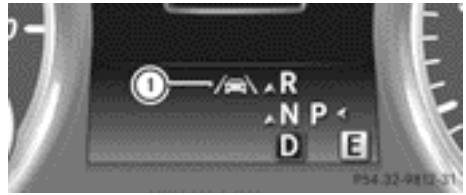

- ▶ Switch on Active Lane Keeping Assist using the on-board computer; to do so, select **Standard** or **Adaptive** (▷ page 279). Symbol ① appears in the multifunction display.

If you drive at speeds above 60 km/h and lane markings are detected, symbol ① is shown in green. Lane Keeping Assist is ready for use.

Standard

If **Standard** is selected, no warning vibration occurs if:

- you have switched on the turn signals. In this case, the warnings are suppressed for a certain period of time.
- a driving safety system intervenes, such as ABS, BAS or ESP®.

Adaptive

If **Adaptive** is selected, no warning vibration occurs if:

- you have switched on the turn signals. In this case, the warnings are suppressed for a certain period of time.
- a driving safety system intervenes, such as ABS, BAS or ESP®.
- you accelerate hard, e.g. kickdown.
- you brake hard.
- you steer actively, e.g. swerve to avoid an obstacle or change lane quickly.
- you cut the corner on a sharp bend.

In order that you are warned only when necessary and in good time if you cross the lane

marking, the system recognises certain conditions and warns you accordingly.

The warning vibration occurs earlier if:

- you approach the outer lane marking on a bend.
- the road has very wide lanes, e.g. a motorway.
- the system recognises solid lane markings.

The warning vibration occurs later if:

- the road has narrow lanes.
- you cut the corner on a bend.

Active Driving Assistance package

General notes

The Active Driving Assistance package consists of DISTRONIC PLUS (▷ page 198), Active Blind Spot Assist (▷ page 242) and Active Lane Keeping Assist (▷ page 246).

Active Blind Spot Assist

Important safety notes

WARNING

Active Blind Spot Assist is only an aid and may detect vehicles/obstacles incorrectly or not at all.

The system may be impaired or may not function if:

- there is poor visibility, e.g. due to snow, rain, fog or spray.
- the rear and/or front sensors are dirty.

Active Blind Spot Assist may not detect narrow vehicles, such as motorcycles or bicycles, or only detect them too late. It cannot detect vehicles which are overtaken at a small distance and then enter the blind spot area.

Active Blind Spot Assist cannot detect road and traffic conditions. It is not a substitute for attentive driving. You are responsible for the vehicle's speed, braking in good time, and steering correctly. Always adapt your driving style to suit the prevailing road and weather

conditions. Always pay attention to traffic conditions and your surroundings. Otherwise, you may fail to recognise dangers in time, cause an accident and injure yourself and others.

The radar sensor system is automatically deactivated near radio telescope facilities (▷ page 433).

For Active Blind Spot Assist to assist you when driving, the radar sensor system must be activated (▷ page 283) and operational.

General notes

Active Blind Spot Assist uses a radar sensor system to monitor the area to the sides of your vehicle which are behind the driver. A warning display in the exterior mirrors draws your attention to vehicles detected in the monitored area. If you then switch on the corresponding turn signal to change lane, you will also receive an optical and audible warning. If a risk of lateral collision is detected, corrective braking may help you avoid a collision. To support the course-correcting brake application, Active Blind Spot Assist uses the forward-facing radar sensor system. The free space in the direction of travel is then evaluated.

Active Blind Spot Assist supports you from a speed of approximately 30 km/h.

Monitoring range

WARNING

Active Blind Spot Assist monitors certain areas in the immediate vicinity of your vehicle. Vehicles that approach and drive past at high speeds are not detected. No visual nor audible warnings are emitted and the system does not brake the vehicle to correct your course.

If the lanes are very wide, it may not be possible to monitor the complete width of the neighbouring lane. For this reason, vehicles in the next lane may not be detected, especially if they are driving in a staggered formation.

This may be the case if vehicles are driving at

the edge of their lane that is furthest away from your vehicle.

Always pay attention to traffic conditions and your surroundings. Otherwise, you may fail to recognise dangers in time, cause an accident and injure yourself and others.

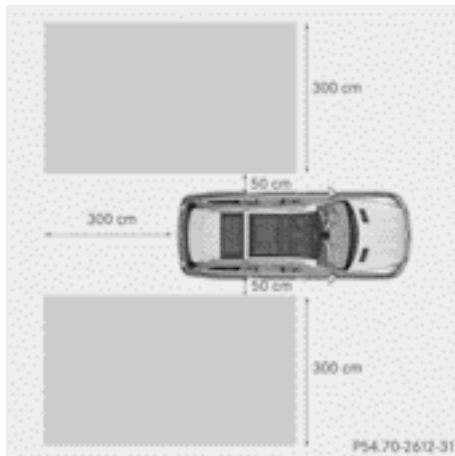

Active Blind Spot Assist monitors the area up to 3.0 m behind your vehicle and directly next to your vehicle, as shown in the diagram. For this purpose, Active Blind Spot Assist uses radar sensors in the rear bumper.

If the lanes are narrow, vehicles driving in the lane beyond the lane next to your vehicle may be indicated, especially if the vehicles are not driving in the middle of their lane. This may be the case if there are vehicles at the inner edge of your lane.

Due to the nature of the system:

- warnings may be issued in error when driving close to crash barriers or similar solid lane borders.
- warnings may be interrupted when driving alongside particularly long vehicles, for example lorries, for a prolonged time.

The Active Blind Spot Assist radar sensors are integrated into the front and rear bumpers and behind a cover in the radiator grille. Make sure that the bumpers and the cover in the radiator grille are free of dirt, ice or slush. The

rear sensors must not be covered, e.g. by bicycle racks or overhanging loads. Following a severe impact or in the event of damage to the bumpers, have the function of the radar sensors checked at a qualified specialist workshop. Active Blind Spot Assist may otherwise no longer work properly.

Indicator and warning display

WARNING

Active Blind Spot Assist is not active at speeds below 30 km/h. The indicator lamps in the exterior mirrors are yellow. Vehicles in the monitoring range are then not indicated.

Always pay attention to traffic conditions and your surroundings. Otherwise, you may fail to recognise dangers in time and cause an accident and injure yourself and others.

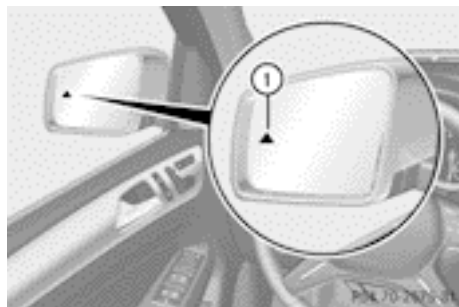

① Yellow indicator lamp/red warning lamp

If Active Blind Spot Assist is switched on, indicator lamps ① in the exterior mirrors light up yellow up to a speed of 30 km/h. At speeds above 30 km/h, the indicator lamp goes out and Active Blind Spot Assist is operational.

If a vehicle is detected within the monitoring range of Blind Spot Assist at speeds above approximately 30 km/h, warning lamp ① on the corresponding side lights up red. This warning always occurs when a vehicle enters the blind spot monitoring range from behind or from the side. When you overtake a vehicle, the warning only occurs if the difference in speed is less than 12 km/h.

The yellow indicator lamp goes out if reverse gear is engaged. Active Blind Spot Assist is then no longer active.

The brightness of the indicator/warning lamps is adjusted automatically according to the ambient light.

Visual and acoustic collision warning

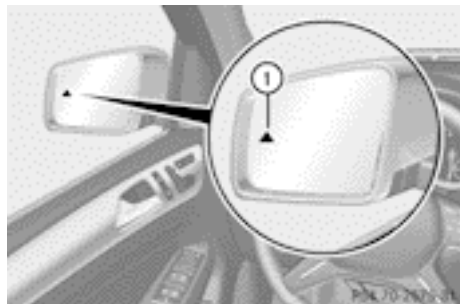

When you switch on the turn signals to change lanes and a vehicle is detected in the side monitoring range, you receive a visual and acoustic collision warning. You then hear a double warning tone and red warning lamp ① flashes. If the turn signal remains on, detected vehicles are indicated by the flashing of red warning lamp ①. There are no further warning tones.

Course-correcting brake application

WARNING

Active Blind Spot Assist is only an aid designed to assist driving. It is not a substitute for attentive driving. Automatic braking by the system may not always be sufficient to avoid a collision. In such cases, you need to steer, brake or accelerate yourself.

In very rare cases, the system may detect a risk of collision where there is none and brake in error near crash barriers or similar road boundaries. Active Blind Spot Assist cannot detect all traffic situations and road users. Ensure at all times that there is sufficient lateral distance between you and other road users or obstacles. You can, for example, countersteer gently or depress the accelera-

tor pedal at any time to cancel inappropriate braking action.

You are responsible for the vehicle's speed, correct steering and for braking in good time. Always adapt your driving style to suit the prevailing road and weather conditions. Always pay attention to traffic conditions and your surroundings. Otherwise, you may fail to recognise dangers in time, cause an accident and injure yourself and others.

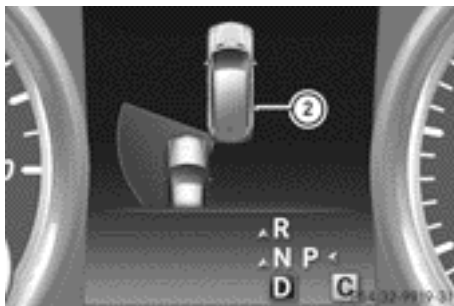
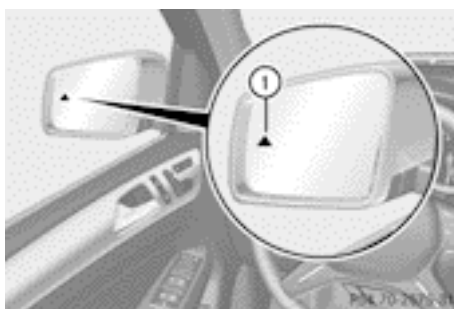

If Active Blind Spot Assist detects a risk of a lateral collision in the monitoring range, a course-correcting brake application is carried out. This is designed to help you avoid a collision.

If a course-correcting brake application occurs, red warning lamp ① flashes in the exterior mirror and a dual warning tone sounds. In addition, display ② appears in the multifunction display.

The course-correcting brake application is available in the speed range between 30 km/h and 200 km/h.

No course-correcting brake application or brake application adapted to the driving conditions occurs if:

- there are vehicles or obstacles, e.g. crash barriers, on both sides of your vehicle.
- a vehicle approaches too closely on the side.
- you have adopted a sporty driving style with high cornering speeds.
- you brake or accelerate decisively.
- a driving safety system intervenes, such as ESP® or PRE-SAFE® Brake.
- ESP® is deactivated.
- the Off-road program is activated (vehicles without the ON&OFFROAD package).
- Off-road program 1 or 2 is activated (vehicles with the ON&OFFROAD package).
- the LOW RANGE off-road gear is activated (vehicles with the ON&OFFROAD package).
- a loss of tyre pressure or a defective tyre is detected.

Activating Active Blind Spot Assist

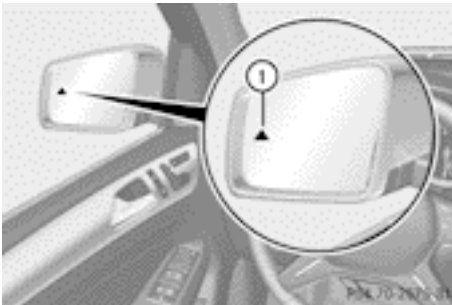

- ▶ Make sure that the radar sensor system (▷ page 283) and Active Blind Spot Assist (▷ page 279) are activated in the on-board computer.
- ▶ Turn the key to position **2** in the ignition lock. Warning lamps ① light up red in the exterior mirrors for approximately 1.5 seconds and then turn yellow.

Towing a trailer

If you attach a trailer, make sure that you have correctly established the electrical connection. This can be accomplished by checking the trailer lighting. Active Blind Spot Assist is then deactivated. The indicator lamp lights up yellow in the exterior mirrors and the **Active Blind Spot Assist currently unavailable** See Owner's Manual message appears in the multifunction display.

Active Lane Keeping Assist

Important safety notes

WARNING

Active Lane Keeping Assist does not keep your vehicle in its lane. It is only an aid and may detect the lane markings on the road incorrectly or not at all.

The system may be impaired or may not function if:

- several or no lane markings for a single lane are present.
- there is poor visibility, e.g. due to insufficient illumination of the road, or due to snow, rain, fog or spray.
- there is glare, e.g. from oncoming traffic, the sun, or reflection from other vehicles.
- the windscreen is dirty, misted up or covered, for instance by a sticker, in the vicinity of the camera.
- the lane markings are worn away, dark or covered up, e.g. by dirt or snow.
- the distance to the vehicle in front is too small and the lane markings thus cannot be detected.
- the lane markings on the road are unclear, e.g. near roadworks.
- the lane markings change quickly, e.g. lanes branch off, cross one another or merge.
- the road is narrow and winding.

Active Lane Keeping Assist cannot detect road and traffic conditions. It is not a substitute for attentive driving. You are responsible

for the vehicle's speed, braking in good time, and steering correctly. Always adapt your driving style to suit the prevailing road and weather conditions. Always pay attention to traffic conditions and your surroundings. Otherwise, you may fail to recognise dangers in time, cause an accident and injure yourself and others.

General notes

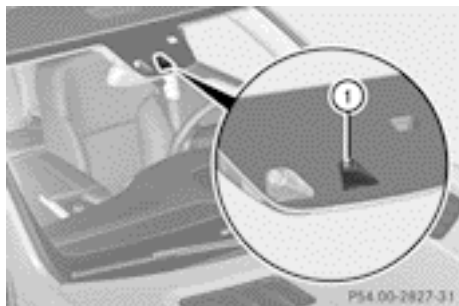

Active Lane Keeping Assist monitors the area in front of your vehicle by means of a camera ① at the top of the windscreen. Active Lane Keeping Assist detects lane markings on the road and warns you before you leave your lane unintentionally. If you do not react to the warning, a lane-correcting application of the brakes can bring the vehicle back into the original lane.

If you select **km** on the on-board computer in the **Display unit Speed-/odometer:** function (▷ page 280), Active Lane Keeping Assist is activated starting at a speed of 60 km/h. If the **miles** display unit is selected, the assistance range begins at 40 mph.

Warning vibration in the steering wheel

A warning may be given if a front wheel passes over a lane marking. It will warn you by means of intermittent vibration in the steering wheel for up to 1.5 seconds.

In order that you are warned only when necessary and in good time if you cross the lane marking, the system recognises certain conditions and warns you accordingly.

The warning vibration occurs earlier if:

- you approach the outer lane marking on a bend.
- the road has very wide lanes, e.g. a motorway.
- the system recognises solid lane markings.

The warning vibration occurs later if:

- the road has narrow lanes.
- you cut the corner on a bend.

Lane-correcting brake application

WARNING

Active Lane Keeping Assist does not keep your vehicle in its lane. It is only an aid designed to assist driving. It is not a substitute for attentive driving. Corrective braking may not always be sufficient to return your vehicle to its original lane. In such cases, you must steer the vehicle yourself to ensure that it does not leave the lane.

Active Lane Keeping Assist cannot detect the current traffic situation or other road users. Ensure at all times that there is sufficient lateral distance between you and other road users or obstacles. In rare cases, broken lines or certain structures on the road surface may be detected by the system as solid lane markings. You can, for example, countersteer gently at any time to cancel inappropriate braking action, e.g. if you intentionally drive across a solid lane marking.

Active Lane Keeping Assist cannot take weather conditions into account.

You are responsible for the vehicle's speed, correct steering and for braking in good time. Always adapt your driving style to suit the prevailing road and weather conditions. Always pay attention to traffic conditions and your surroundings. Otherwise, you may fail to recognise dangers in time, cause an accident and injure yourself and others.

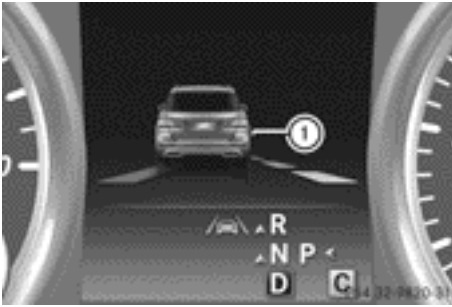

If a lane-correcting brake application occurs, display ① appears in the multifunction display.

If you leave your lane under certain circumstances, the vehicle will brake briefly on one side. This is designed to help you bring the vehicle back into the original lane.

This function is available in the range between 60 km/h and 200 km/h.

A lane-correcting brake application can only be made after driving over a solid, recognisable lane marking. Before this, a warning must be emitted by means of intermittent vibration in the steering wheel. In addition, a lane with lane markings on both sides must be recognised. The brake application also slightly reduces driving speed.

i A further lane-correcting brake application can only occur after your vehicle has returned to the original lane.

No lane-correcting brake application occurs if:

- you clearly and actively steer, brake, or accelerate.
- you cut the corner on a sharp bend.
- you have switched on the turn signal.
- a driving safety system intervenes, such as ESP[®], PRE-SAFE[®] Brake or Active Blind Spot Assist.
- you have adopted a sporty driving style with high cornering speeds or high rates of acceleration.
- ESP[®] is deactivated.
- the transmission is not in position **D**.

- on vehicles with a trailer tow hitch, the electrical connection to the trailer has been correctly established.
- the Off-road program is activated (vehicles without the ON&OFFROAD package).
- Off-road program 1 or 2 is activated (vehicles with the ON&OFFROAD package).
- the LOW RANGE off-road gear is activated (vehicles with the ON&OFFROAD package).
- a loss of tyre pressure or a defective tyre has been detected and displayed.

Active Lane Keeping Assist does not detect road and traffic conditions. An inappropriate brake application may be interrupted at any time if:

- you steer slightly in the opposite direction.
- you switch on the turn signal.
- you clearly brake or accelerate.

A lane-correcting brake application is interrupted automatically if:

- a driving safety system intervenes, such as ESP[®], PRE-SAFE[®] Brake or Active Blind Spot Assist.
- lane markings can no longer be recognised.

Activating Active Lane Keeping Assist

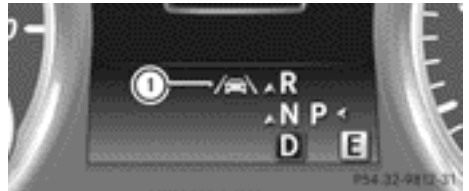

- Switch on Active Lane Keeping Assist using the on-board computer; to do so, select **Standard** or **Adaptive** (> page 279). Symbol ① appears in the multifunction display.

If **Standard** is selected, no warning vibration occurs if:

- you have switched on the turn signals. In this event, the warnings are suppressed for a certain period of time.
- a driving safety system intervenes, such as ABS, BAS or ESP®.

If **Adaptive** is selected, no warning vibration occurs if:



- you have switched on the turn signals. In this event, the warnings are suppressed for a certain period of time.
- a driving safety system intervenes, such as ABS, BAS or ESP®.
- you accelerate hard, e.g. kickdown.
- you brake hard.
- you steer actively, e.g. swerve to avoid an obstacle or change lane quickly.
- you cut the corner on a sharp bend.

Towing a trailer

If you attach a trailer, make sure that you have correctly established the electrical connection. This can be accomplished by checking the trailer lighting.

On-road programs (vehicles with the ON&OFFROAD package)

General notes

The on-road programs support you when driving on roads and the off-road programs support you when driving off-road (> page 253). The following program messages remain in the multifunction display until the corresponding vehicle level has been set. Up to off-road level 2, you can hide the program messages using the  or  button on the multifunction steering wheel.

AUTO program

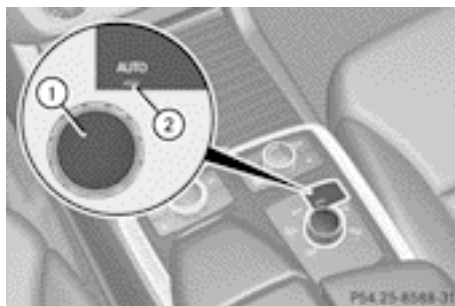

Select the AUTO program for a more comfortable ride under all normal driving conditions.

Your selection remains stored even if you remove the key from the ignition lock.

- **Selector wheel ① engaged:** briefly press selector wheel ①.
Selector wheel ① extends.
- **To select:** turn selector wheel ① until indicator lamp ② comes on.
AUTO indicator ③ appears in the multifunction display.
 - Highway level is set.
 - ADS (Adaptive Damping System) adjusts the comfort damping characteristics to the current operating and driving conditions.
 - The automatic transmission selects the automatic drive program for a comfortable and efficient driving style.

SPORT program



Select the SPORT program for sporty driving dynamics.

Your selection remains stored even if you remove the key from the ignition lock.

- ▶ **Selector wheel ① engaged:** briefly press selector wheel ①.
Selector wheel ① extends.
- ▶ **To select:** turn selector wheel ① until indicator lamp ② comes on.
SPORT indicator ③ appears in the multi-function display.
 - High-speed level, -15 mm compared to highway level, is set.
 - ADS (Adaptive Damping System) adjusts the sporty damping characteristics to the current operating and driving conditions.
 - The automatic transmission selects the automatic drive program for a sporty driving style.
 - The sporty accelerator pedal curve is selected. This means that the accelera-

tor pedal does not need to be depressed as far when accelerating.

- The sporty steering curve is selected. This means that more effort is required when steering.
- ❗ You cannot select the SPORT program if LOW RANGE has been selected. The **Drive program SPORT Not in LOW RANGE** message then appears in the multi-function display.

Snow program



Select the snow program when driving in snow or with snow chains.

- ▶ **Selector wheel ① engaged:** briefly press selector wheel ①.
Selector wheel ① extends.
- ▶ **To select:** turn selector wheel ① until indicator lamp ② comes on.
Snow indicator ③ appears in the multi-function display.

- Highway level is set.
- ADS (Adaptive Damping System) adjusts the comfort damping characteristics to the current operating and driving conditions.
- 4ETS and the differential lock are adapted for driving on snow-covered roads.
- The automatic transmission selects the automatic drive program for a comfortable and efficient driving style.
- The smooth accelerator pedal curve is selected. This means that the accelerator pedal needs to be depressed much further when accelerating.
- The optimal gear for pulling away is engaged.

Trailer program



Select the trailer program when towing a trailer.

- ▶ **Selector wheel ① engaged:** briefly press selector wheel ①.
Selector wheel ① extends.
- ▶ **To select:** turn selector wheel ① until indicator lamp ② comes on.
Trailer indicator ③ appears in the multi-function display.
 - Highway level is set.
 - ADS (Adaptive Damping System) adjusts the comfort damping characteristics to the current operating and driving conditions.
 - The automatic transmission selects the automatic drive program for a comfortable and efficient driving style, and the shift points are optimally adjusted.
 - The differential lock is engaged when pulling away.

Off-road driving systems

4MATIC (permanent all-wheel drive)

⚠ WARNING

4MATIC cannot reduce the risk of an accident if you drive too fast.

If a drive wheel spins due to insufficient grip:

- only depress the accelerator pedal as far as necessary when pulling away.
- accelerate less when driving.
- adapt your driving style to suit road and traffic conditions.

- ⚠ Never tow the vehicle with one axle raised. This may damage the transfer case. Damage of this sort is not covered by the Mercedes-Benz implied warranty. All wheels must remain either on the ground or be fully raised. Observe the instructions for towing the vehicle with all wheels in full contact with the ground.

- ⚠ A function or performance test should only be carried out on a twin-axle dynamometer. Before you operate the vehicle

on such a dynamometer, please consult a qualified workshop. You could otherwise damage the drive train or the brake system.

4MATIC ensures that all four wheels are permanently driven. Together with ESP® and 4ETS, it improves the traction of your vehicle whenever a drive wheel spins due to insufficient grip.

i In wintry driving conditions, the maximum effect of 4MATIC can only be achieved if you use winter tyres (M+S tyres), with snow chains if necessary.

For further information on "Driving off-road", see (> page 188).

DSR (Downhill Speed Regulation)

Important safety notes

WARNING

DSR is only an aid designed to assist you when driving downhill. You are responsible for keeping control of the vehicle and for assessing whether the downhill gradient can be managed.

When activating DSR the vehicle may brake suddenly due to DSR intervening. This is dependent on the downhill gradient and the difference between the current speed and the speed set. DSR may not always be able to keep to the set speed, depending on road surface and tyre conditions. You could lose control of the vehicle and cause an accident.

Select a set speed suitable for the prevailing conditions and when necessary, apply the brakes manually.

WARNING

If you depress the accelerator pedal with DSR activated, then the set speed can be exceeded. Drive downhill with special care and always keep in mind that DSR brakes the vehicle as soon as you remove your foot from the accelerator pedal. The vehicle may brake suddenly due to DSR intervening, depending on the downhill gradient and the difference

between the current speed and the set speed. You could lose control of the vehicle and cause an accident.

DSR assists you when driving downhill. It keeps the speed of travel at the speed set on the on-board computer. The steeper the downhill gradient, the greater the DSR braking effect on the vehicle. When driving on flat stretches of road or on an uphill gradient, the DSR braking effect is minimal or non-existent. DSR controls the set speed when it is active and the automatic transmission is in the **D**, **R** or **N** position. By accelerating or braking, you can always drive at a higher or a lower speed than that set on the on-board computer.

Further information about "Driving off-road" (> page 188).

Activating DSR



Example: vehicles with the ON&OFFROAD package

- ① DSR button
- ② DSR indicator lamp

► Press button ①.
Indicator lamp ② lights up.

The  DSR symbol appears in the multifunction display.

You can only activate DSR when driving at speeds below 40 km/h.

If the current vehicle speed is too high, the  DSR symbol appears in the multifunction display with the **Max. speed 40 km/h** message.

i You cannot activate DSR if the SPORT on-road program is activated. The  DSR symbol and the **Not in drive program SPORT** message then appear in the multifunction display.

Deactivating DSR

► Press button **①**.
Indicator lamp **②** goes out.

The  DSR symbol appears in the multifunction display with the **off** message.

DSR switches off automatically if you drive faster than 45 km/h. The  DSR symbol appears in the multifunction display with the **off** message. The status indicator in the multifunction display goes out. You also hear a warning tone. On vehicles with the ON&OFFROAD package, if you select a different on-road/off-road program, DSR is also deactivated.

Changing the set speed

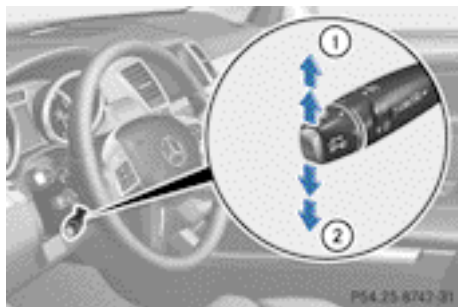

► **To increase or reduce the set speed in 1 km/h increments:** briefly press the

cruise control lever, up **①** for a higher set speed or down **②** for a lower set speed.

The set speed appears in the multifunction display with the  DSR symbol. It is also displayed in status indicator **③**.

When DSR is activated, you can change the set speed to a value between 2 km/h and 18 km/h.

i The DSR set speed is always changed in 1 km/h increments. This is regardless of whether you press the cruise control lever to or beyond the pressure point.

Off-road program (vehicles without the ON&OFFROAD package)

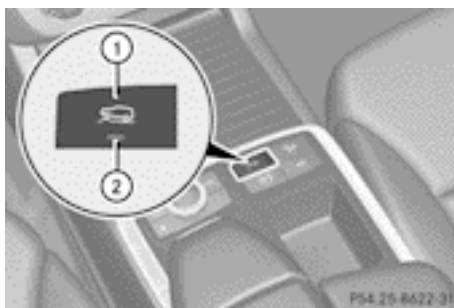

- ① Off-road program button
- ② Off-road program indicator lamp

► **To switch on:** press button **①**.
Indicator lamp **②** lights up. The  off-road indicator appears in the multifunction display.

► **To switch off:** press the **①** button.
Indicator lamp **②** and the  off-road indicator go out in the multifunction display.

The off-road program assists you in driving off-road. The engine's performance characteristics and the gearshifting characteristics of the automatic transmission are adapted for this purpose. ABS, ESP® and 4ETS programs especially adapted to off-road driving are activated. A gentle accelerator pedal curve is also selected, i.e. the accelerator pedal must be

depressed much further in order to accelerate.

Do not use the off-road program on roads that are snow-covered or icy or if you have fitted your vehicle with snow chains.

For information about driving off-road, see (▷ page 188).



Off-road programs (vehicles with the ON&OFFROAD package)

General notes

The off-road programs assist you in driving off-road. The engine's performance characteristics and the gearshifting characteristics of the automatic transmission are adapted for this purpose. ABS, ESP® and 4ETS programs especially adapted to off-road driving are activated. An accelerator pedal curve suitable for the terrain is selected, i.e. the accelerator pedal must be depressed further to accelerate.

Do not use the off-road programs on roads that are snow-covered or icy or if you have fitted your vehicle with snow chains.

For information about driving off-road, see (▷ page 188).

The following program messages remain in the multifunction display until the corresponding vehicle level has been set. Up to off-road level 2, you can hide the program messages using the  or the  button on the multifunction steering wheel.

Off-road program 1



- ▶ **Selector wheel ① engaged:** briefly press selector wheel ①.
Selector wheel ① extends.
- ▶ **To select:** turn selector wheel ① until indicator lamp ② comes on.
Off-road indicator ③ appears in the multifunction display.
Off-road level 1 is set to +30 mm above the highway level.

Off-road program 1 switches to the AUTO program if you drive faster than 110 km/h. Select off-road program 1 for easily negotiable off-road terrain, e.g. for gravel or sand surfaces or tracks. The engine's torque is restricted to a limited degree and the drive wheels can spin. The spinning of the wheels results in a cutting action for better traction. You can only activate off-road program 1 when driving at speeds below 100 km/h. The **Drive program OFFROAD 1 Max. speed 100 km/h** message appears in the multifunction display.

Off-road program 2

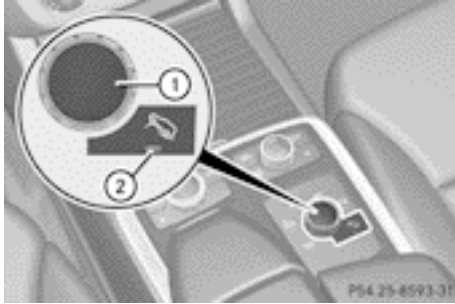

- ▶ **Selector wheel ① engaged:** briefly press selector wheel ①.
Selector wheel ① extends.
- ▶ **To select:** turn selector wheel ① until indicator lamp ② comes on.
Off-road indicator ③ appears in the multi-function display.
 - off-road level 2 is set and the vehicle is raised by +60 mm compared to the highway level.
 - DSR is switched on.
 - the differential lock is closed.

Off-road program 2 automatically switches to off-road program 1 if you drive faster than 45 km/h.

Select off-road program 2 for rough terrain, e.g. for steep and/or uneven terrain or for driving on rocky terrain.

- ❗ Your vehicle has an automatically activated differential lock for the transfer case. It controls the balance between the front and rear axles.

The differential lock improves the vehicle's traction. 4ETS (▷ page 66) controls the balance between both wheels on an axle.

You can only activate off-road program 2 when driving at speeds below 40 km/h.

LOW RANGE off-road gear (vehicles with the ON&OFFROAD package)

General notes

⚠ WARNING

Always wait for the gear change process from HIGH RANGE to LOW RANGE – and from LOW RANGE to HIGH RANGE – to complete. Do not turn off the engine while changing gear and do not switch the automatic transmission to another gear.

If you do not wait for the gear change process to complete, it may not be correctly implemented. The transfer case may then be in neutral and the connection between the engine and the drive axles may be disengaged. The vehicle could then move freely, even if a gear is engaged, and could inadvertently start moving, particularly if it is on a slope.

Observe the following description in "Messages in the multifunction display".

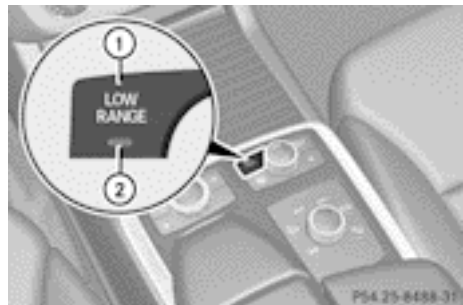

- ① LOW RANGE off-road gear button
- ② LOW RANGE off-road gear indicator lamp

HIGH RANGE	Position for all normal on-road driving conditions.
LOW RANGE	<p>Off-road position for driving off-road and fording. The transmission ratio between the engine and wheels is only approximately one third of that in the HIGH RANGE road position. The drive torque is correspondingly higher as a result.</p> <p>Do not use LOW RANGE:</p> <ul style="list-style-type: none"> • on slippery road surfaces, e.g. in the event of slush • on snow or ice-covered roads • if you have snow chains on your vehicle

The LOW RANGE off-road gear assists you when driving off-road and when fording. When LOW RANGE is engaged, the engine's performance characteristics and the gearshifting characteristics of the automatic transmission are adapted for this purpose.

Further information about "Driving off-road" (▷ page 188). You will find information about driving safety systems in conjunction with LOW RANGE in the "Safety" section (▷ page 60).

From HIGH RANGE to LOW RANGE

! Only change from HIGH RANGE to LOW RANGE if:

- the engine is running
- the transmission is in position **N**
- you are driving at speeds below 40 km/h

► Press LOW RANGE button ①.

Indicator lamp ② flashes.

Once the gear change procedure is complete, indicator lamp ② lights up. The LOW

RANGE display appears in the multifunction display and in the status indicator.

While indicator lamp ② is flashing, you can cancel the gear change by pressing LOW RANGE button ① again.

i You cannot activate LOW RANGE if the SPORT on-road program is activated. The **LOW RANGE Not in drive program SPORT** message then appears in the multifunction display.

From LOW RANGE to HIGH RANGE

! Only change from HIGH RANGE to LOW RANGE if:

- the engine is running
- the transmission is in position **N**
- if you are driving at speeds below 70 km/h

► Press LOW RANGE button ①.

Indicator lamp ② flashes.

When the gear change is complete, indicator lamp ② goes out. In the multifunction display, the **LOW RANGE Off** message appears and status indicator ③ goes out.

While indicator lamp ② is flashing, you can cancel the gear change by pressing LOW RANGE button ① again.

Messages in the multifunction display

If a gear change process has not been successful, the following messages may be displayed in the multifunction display:

Display messages	Possible causes/consequences and ► Solutions
LOW RANGE max. speed 40 km/h	You have been driving faster than 40 km/h. Additionally, the indicator lamp on the button in the centre console blinks. ► Drive more slowly to carry out the gear change process.
LOW RANGE Shift to position N briefly	The transmission is in position D and you are driving at below 40 km/h. ► Shift the transmission to N to complete the gear change process.
LOW RANGE Shifting cancelled Please reactivate	The gear change process was not carried out. ► Maintain all gear change conditions and carry out the gear change process again.
LOW RANGE Stop Apply parking brake	A warning tone also sounds. The gear change process has not been completed. LOW RANGE is in the neutral position. There is no connection between the engine and the drive wheels. ! Do not drive any further. You could otherwise damage the vehicle's drive train. ► Stop the vehicle. Take into account the road and traffic conditions when doing so. ► Apply the electric parking brake (► page 182). ► Repeat the gear change process. If the gear change process has been carried out, the LOW RANGE Stop Apply parking brake message disappears.

ONOFFROAD menu in the COMAND display (vehicles with the ON&OFFROAD package)

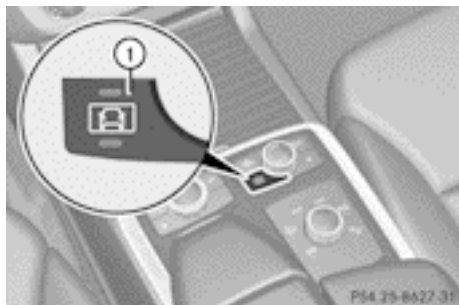

You can display some driving systems, driving programs and additional information in the COMAND display.

- Make sure that the key is in position **2** in the ignition lock.
- Make sure that COMAND Online is activated, see the separate COMAND operating instructions.
- Press function button **1**.
The corresponding displays appear in the COMAND display:
 - level control
 - steering angle
 - vehicle's angle of inclination

- uphill or downhill gradient in percentage
- on-road/off-road program selected
- condition of the differential lock for the transfer case
- the LOW RANGE off-road gear is selected
- condition of the LOW RANGE off-road gear
- the on-road trailer program is selected

Towing a trailer

Notes on towing a trailer

Important safety notes

WARNING

Vehicles with level control:

The vehicle level can be changed inadvertently, e.g. when changed by another person. If you are coupling up or uncoupling a trailer when this happens, you could become trapped. Body parts can also become trapped between the vehicle body and tyres, or underneath the vehicle. This poses a risk of injury. When coupling up or uncoupling, make sure that no-one:

- opens or closes the doors or tailgate
- initiates the level control or presses the ADS switch
- locks or unlocks the vehicle.

WARNING

The braking system can overheat if you leave your foot on the brake pedal while driving. This increases the braking distance and could even cause the braking system to fail. There is a risk of an accident.

Never use the brake pedal as a footrest. Do not simultaneously depress both the brake pedal and the accelerator pedal while driving.

WARNING

You could lose control of the vehicle/trailer combination if it begins to swerve. The vehi-

cle/trailer combination could even overturn. There is a risk of an accident.

On no account should you attempt to straighten out the vehicle/trailer combination by increasing speed. Decrease your speed and do not countersteer. Brake if necessary.

WARNING

If you exceed the permissible noseweight while carrying a load, the carrier system could detach from the vehicle and fall on the road. There is a risk of an accident and injury. Always maintain the permissible noseweight when carrying loads.

WARNING

If the ball coupling is not correctly engaged, it could detach while driving and fall on the road. There is a risk of an accident and injury. Engage the ball coupling as described.

WARNING

If the ball coupling is not correctly engaged, the trailer can detach. There is a risk of an accident.

Always engage the ball coupling as described.

- ❗ Depressing the brake pedal constantly results in excessive and premature wear to the brake pads.

You can use carrier systems, e.g. bicycle racks or load-bearing implements, on the ball coupling. The maximum noseweight of 75 kg applies when using carrier systems on the ball coupling.

When reversing the vehicle towards the trailer, make sure there is nobody between the trailer and the vehicle.

Couple and uncouple the trailer carefully. If you do not couple the trailer to the towing vehicle correctly, the trailer could become detached.

Make sure that the following values are not exceeded:

- the permissible trailer drawbar noseweight
- the permissible trailer load
- the permissible rear axle load of the towing vehicle
- the maximum permissible gross vehicle weight of both the towing vehicle and the trailer

The applicable permissible values, which must not be exceeded, can be found:

- in the vehicle documents
- on the identification plates of the trailer tow hitch, the trailer and the vehicle

If the values differ, the lowest value applies.

You will find the values approved by the manufacturer on the vehicle identification plates and those for the towing vehicle under "Technical data" (▷ page 433).

When towing a trailer, your vehicle's handling characteristics will be different in comparison to when driving without a trailer.

The vehicle/trailer combination:

- is heavier
- is restricted in its acceleration and gradient-climbing capability
- has an increased braking distance
- is affected more by strong crosswinds
- demands more sensitive steering
- has a larger turning circle

This could impair the handling characteristics. Adapt your style of driving accordingly. Maintain a safe distance. Drive carefully.

When towing a trailer, always adjust your speed to the current road and weather conditions. Do not exceed the maximum permissible speed for your vehicle/trailer combination.

General notes

! Use a drawbar noseweight as close as possible to the maximum permissible noseweight. Do not use a noseweight of less

than 50kg, otherwise the trailer may come loose.

Note that the payload and the rear axle load are reduced by the actual payload.

- i** Check the tyre pressures when towing a trailer. You will find the values in the tyre pressure table in the fuel filler flap of the vehicle (▷ page 399).

You will find installation dimensions and loads in the "Technical data" section (▷ page 432).

The maximum permissible trailer drawbar noseweight on the ball coupling is 140 kg. However, the actual noseweight must not exceed the value given on the trailer tow hitch or trailer identification plates. The lowest weight applies.

Please note that when towing a trailer, PARKTRONIC (▷ page 216) and Blind Spot Assist (▷ page 238) are only available with limitations, or not at all.

Driving tips

- i** Observe the information on ESP® trailer stabilisation (▷ page 67) and on pulling away with a trailer. (▷ page 162).

Vehicles with the ON&OFFROAD package: select the trailer program (▷ page 250) with the off-road program selector wheel in the centre console.

The maximum permissible speed for vehicle/trailer combinations depends on the type of trailer. Before beginning the journey, check the trailer's documents to see what the maximum permitted speed is. Observe the legally prescribed maximum speed in the relevant country.

For certain Mercedes-Benz vehicles, the maximum permissible rear axle load is increased when towing a trailer. See "Technical data" to find out whether this applies to your vehicle (▷ page 433). If you utilise any of the added maximum rear axle load when towing a trailer, the vehicle/trailer combination may not exceed a maximum speed of 100 km/h for

reasons concerning the operating permit. This also applies in countries in which the permissible maximum speed for vehicle/trailer combinations is above 100 km/h. When towing a trailer, your vehicle's handling characteristics will be different in comparison to when driving without a trailer and it will consume more fuel.

On long and steep downhill gradients, you must select shift range **1**, **2** or **3** in good time.

i This also applies if you have activated cruise control, SPEEDTRONIC or DIS-TRONIC PLUS.

This will use the braking effect of the engine, so less braking will be required to prevent the vehicle from gaining speed. This relieves the load on the brake system and prevents the brakes from overheating and wearing too quickly. If you need additional braking, depress the brake pedal repeatedly rather than continuously.

Driving tips

If the trailer swings from side to side:

- ▶ Do not accelerate.
- ▶ Do not countersteer.
- ▶ Brake if necessary.
- Maintain a greater distance from the vehicle in front than when driving without a trailer.
- Avoid braking abruptly. If possible, brake gently at first to allow the trailer to run on. Then, increase the braking force rapidly.
- The values given for gradient-climbing capabilities from a standstill refer to sea level. When driving in mountainous areas, note that the power output of the engine, and consequently the vehicle's gradient-climbing capability, decrease with increasing altitude.

Folding out the ball coupling

⚠ WARNING

If the ball coupling is not correctly engaged, the trailer can detach. There is a risk of an accident.

Always engage the ball coupling as described.

⚠ WARNING

If you release the ball coupling or it does not engage correctly when folding in, it will swing out. Within pivoting range of the ball coupling, there is an increased risk of an accident and injury.

Only release the ball coupling if the pivoting range is unobstructed. Always make sure that the ball coupling engages when folding in.

! **AMG vehicles and vehicles with AMG bodystyling:** remove the cover below the bumper before you fold out the ball coupling. Otherwise, the ball coupling, the cover and the bumper could be damaged.

Before you can tow a trailer with your vehicle, you must fold out the ball coupling.

- ▶ Make sure that the vehicle is stationary.

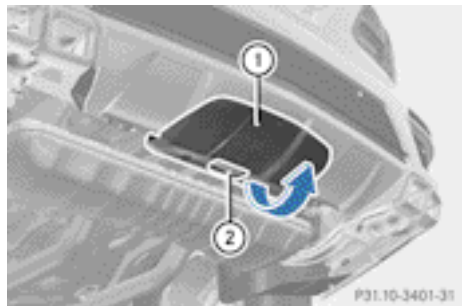

- ▶ **AMG vehicles and vehicles with AMG bodystyling:** pull down cover ① by handle ② in the direction of the arrow until it is released.

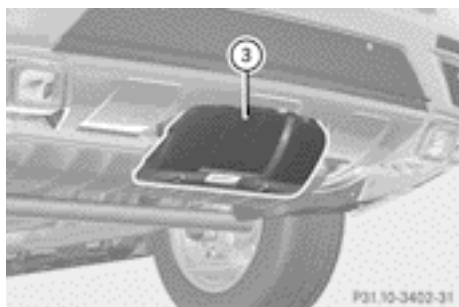

- ▶ **AMG vehicles and vehicles with AMG bodystyling:** release cover ③ from the bracket at the rear and stow it safely.



- ▶ Open the tailgate.
- ▶ Pull release knob ① until the ball coupling unlocks.
The ball coupling folds out from under the rear bumper.
The indicator lamp on the release knob flashes. The trailer socket folds away automatically.



- ▶ Press the ball coupling in the direction of the arrow until it engages in a vertical position.
The indicator lamp on the release knob goes off.
The multifunction display shows the **Check trailer hitch lock** message until the ball coupling is engaged.
- ▶ Remove the protective covering from the ball coupling and store it in a safe place.

Coupling up a trailer

Important safety notes

WARNING

Vehicles with level control:

If you disconnect the trailer cable, the vehicle is lowered. This can cause you or others to become trapped between the vehicle body and tyres, or underneath the vehicle. This poses a risk of injury.

Make sure that no-one is in the immediate vicinity of the wheel arch or underneath the vehicle when disconnecting the trailer cable.

Vehicles with the AIRMATIC package

- ▶ Make sure that the transmission is in position **P**.
- ▶ Engage the electric parking brake.
- ▶ Start the engine.
- ▶ Set the vehicle to highway level (▷ page 213).
- ▶ Set the Adaptive Damping System (ADS) to **AUTO** or **COMF** (▷ page 212).
- ▶ Switch off the engine.
- ▶ Close the doors and tailgate.
- ▶ Position the trailer level behind the vehicle.
- ▶ Couple up the trailer.
- ▶ Establish the electric connection between the vehicle and the trailer.
- ▶ Check that the trailer lighting system is working.

- i** If you have coupled a trailer, the vehicle will remain at highway level.

The vehicle automatically lowers to highway level if you drive faster than 30km/h with a trailer. The vehicle is not lowered to high-speed level even if you are travelling at higher speeds.

This also applies when using accessories that are plugged into the socket of the trailer tow hitch (e.g. a bicycle rack).

Uncoupling a trailer

Important safety notes

⚠ WARNING

If you uncouple a trailer with an engaged overrun brake, you could trap your hand between the vehicle and the trailer drawbar. This poses a risk of injury.

Do not uncouple a trailer with an engaged overrun brake.

⚠ WARNING

Vehicles with level control:

If you disconnect the trailer cable, the vehicle is lowered. This can cause you or others to become trapped between the vehicle body and tyres, or underneath the vehicle. This poses a risk of injury.

Make sure that no-one is in the immediate vicinity of the wheel arch or underneath the vehicle when disconnecting the trailer cable.

- !** Do not disconnect a trailer with an engaged overrun brake. Otherwise, your vehicle could be damaged by the rebounding of the overrun brake.
- !** Remove the installed adapter cable before folding in the ball coupling. Otherwise, damage may occur to the rear bumper and the adapter cable.

Vehicles with the AIRMATIC package

- ▶ Make sure that the transmission is in position **P**.
- ▶ Engage the electric parking brake.
- ▶ Start the engine.
- ▶ Close the doors and tailgate.
- ▶ Secure the trailer against rolling away.
- ▶ Remove the trailer cable and decouple the trailer.
- ▶ Switch off the engine.

Folding in the ball coupling

⚠ WARNING

If you release the ball coupling or it does not engage correctly when folding in, it will swing out. Within pivoting range of the ball coupling, there is an increased risk of an accident and injury.

Only release the ball coupling if the pivoting range is unobstructed. Always make sure that the ball coupling engages when folding in.

Fold the ball coupling back in if you are not using the trailer tow hitch.

- ▶ Make sure that the vehicle is stationary and the trailer cables are disconnected.
- ▶ Place the protective covering on the ball coupling.
- ▶ Open the tailgate.



- ▶ Pull release knob ① until the ball coupling unlocks.

The ball coupling folds down from under the rear bumper. The indicator lamp on the release knob flashes.

- ▶ **i** Do not attempt to speed up this process by using your foot to apply additional pressure. Otherwise, the system may sustain mechanical damage.



- ▶ Press the ball coupling in the direction of the arrow until it engages audibly behind the bumper.

The indicator lamp on the release knob goes out and the message in the multifunction display disappears.

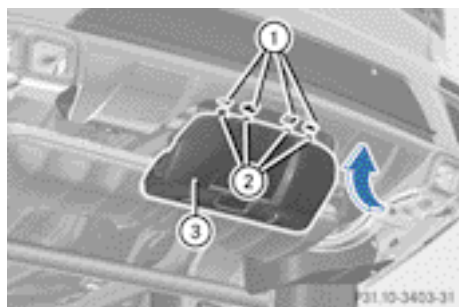

- ▶ **AMG vehicles and vehicles with AMG bodystyling:** attach hooks ② of cover ③ in the direction of the arrow into openings ① intended for this purpose.

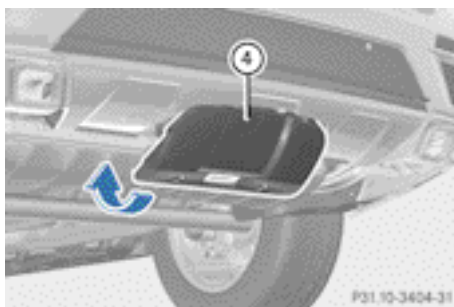

- ▶ **AMG vehicles and vehicles with AMG bodystyling:** push cover ④ upwards in the direction of the arrow until it engages.
- ▶ **AMG vehicles and vehicles with AMG bodystyling:** check that cover ④ has been attached correctly.

Trailer power supply

- ▶ You can connect accessories with a power rating of up to 240 W to the permanent power supply and with a power rating of up to 180 W to the power supply that is switched on via the ignition lock.

The trailer battery may not be charged from the power supply.

When it leaves the factory, your vehicle's trailer socket is equipped with a permanent power supply and a power supply that is switched on via the ignition lock.

The permanent power supply is supplied via trailer socket pin 9.

The power supply that is switched on via the ignition lock is supplied via trailer socket pin 10.

The trailer's permanent power supply is switched off in the event of low vehicle supply voltage and after six hours at the latest.

You can find more information about fitting the trailer electrics at a qualified specialist workshop.

- ▶ **To switch the connected power supply on or off:** turn the key in the ignition lock

to position **2** or **0** respectively
(▷ page 159).

Bulb failure indicator for LED lamps

- i** If LED lamps are fitted in the trailer, an error message may appear in the multi-function display even if there is no fault. The reason for the error message could be that the current has fallen below the minimum of 50 mA.

To ensure reliable operation of the bulb failure indicator, each LED chain in the trailer lighting must be guaranteed a minimum current of 50 mA.

Trailer with 7-pin connector

General notes

Trailers with 7-pin connector: you can make a connection to the 13-pin connector on the ball coupling using an adapter plug or, if necessary, an adapter cable. Both can be obtained in a qualified specialist workshop.

Fitting the adapter

- !** Make sure that there is sufficient cable play so that the cable cannot become detached when cornering.
- !** Remove the installed adapter cable before folding in the ball coupling. Otherwise, damage may occur to the rear bumper and the adapter cable.

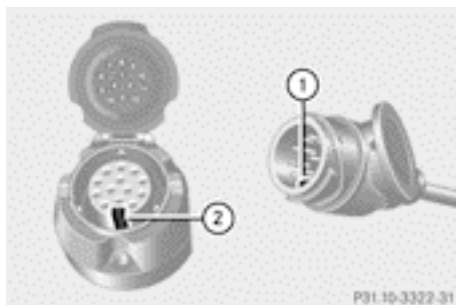

- ▶ Open the socket cover.
- ▶ Insert connector with lug **①** into groove **②** of the socket. Turn the connector clockwise to the stop.
- ▶ Let the cover engage.
- ▶ If you are using an adapter cable, secure the cable to the trailer with cable ties.

Problems with trailer towing

Problem	Possible causes/consequences and ► Solutions
The released ball coupling cannot be engaged.	► Visit a qualified specialist workshop.
<p>The ball coupling does not unlock, even though:</p> <ul style="list-style-type: none"> • the vehicle is stationary • no trailer cable is connected • the release knob to unlock the ball coupling has been pulled for more than a second. 	<p>The on-board voltage is insufficient.</p> <p>► Start the engine.</p> <p>If the ball coupling still does not unlock:</p> <p>► Visit a qualified specialist workshop.</p>

Useful information	266
Important safety notes	266
Displays and operation	267
Menus and submenus	271
Display messages	290
Warning and indicator lamps in the instrument cluster	324

Useful information

- i** This Owner's Manual describes all models, series and optional equipment for your vehicle that were available at the time of going to press. National variations are possible. Note that your vehicle may not be equipped with all of the functions described. This is also the case for systems and functions relevant to safety.
- i** Read the information on qualified specialist workshops: (▷ page 25).

Important safety notes

 **WARNING**

Only use the on-board computer when road and traffic conditions permit. You would otherwise be distracted and unable to concentrate properly on driving, and could cause an accident.

 **WARNING**

No messages will be displayed if either the instrument cluster or the multifunction display is inoperative.

As a result, you will not be able to see information about your driving conditions, such as speed, outside temperature, warning and indicator lamps, display messages or system failures. Driving characteristics may be impaired. Adjust your driving style and vehicle speed accordingly.

Contact a qualified specialist workshop immediately.

 **WARNING**

The on-board computer only records and displays malfunctions and warnings from certain systems. For this reason, you should always make sure that your vehicle is safe to use. You could otherwise cause an accident by driving an unsafe vehicle.

 **WARNING**

The operating safety of your vehicle could be impaired if maintenance work is carried out incorrectly. This could cause you to lose control of your vehicle and cause an accident. Moreover, the safety systems may no longer be able to protect you or others as they are designed to do.

Always have service work carried out at a qualified specialist workshop.

For an illustration of the instrument cluster, see (▷ page 30).

Displays and operation

Instrument cluster

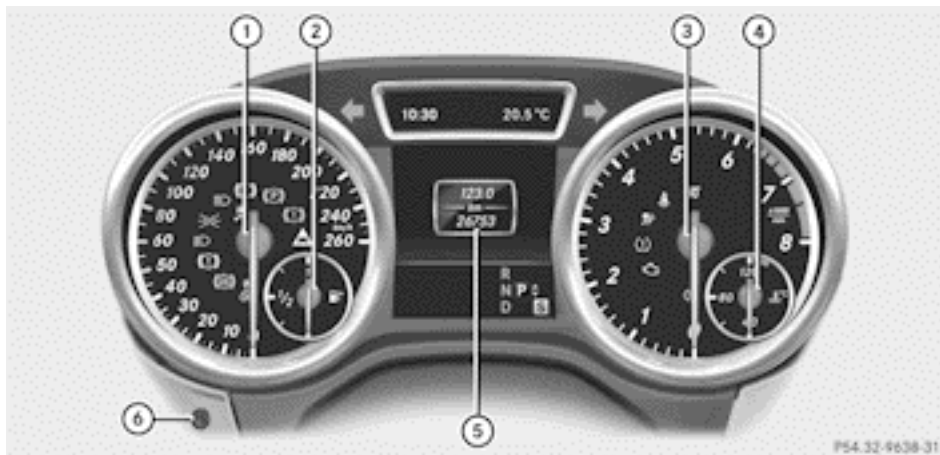

P54.32-9638-31

Instrument cluster: kilometres

- ① Speedometer with segments (▷ page 268)
- ② Fuel gauge
- ③ Rev counter (▷ page 268)
- ④ Coolant temperature (▷ page 268)
- ⑤ Multifunction display (▷ page 270)
- ⑥ Instrument cluster lighting (▷ page 268)

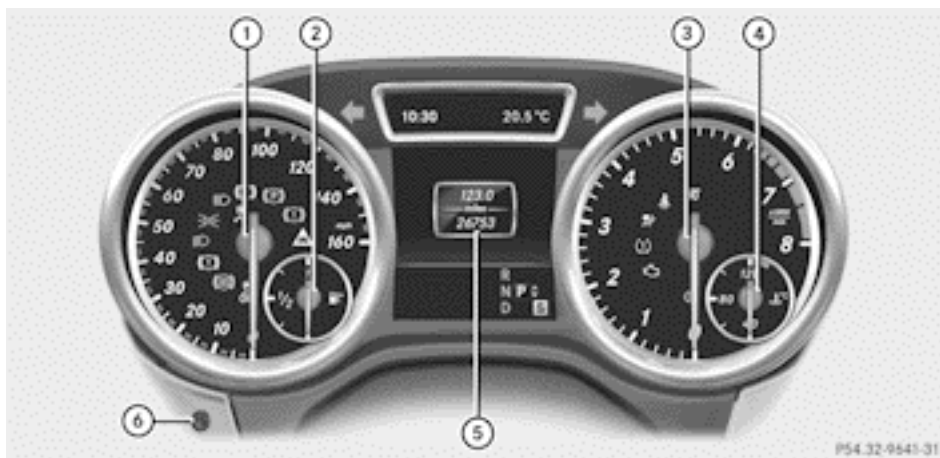

P54.32-9645-31

Instrument cluster: miles

- ① Speedometer with segments (▷ page 268)
- ② Fuel gauge



- ③ Rev counter (▷ page 268)
- ④ Coolant temperature (▷ page 268)
- ⑤ Multifunction display (▷ page 270)
- ⑥ Instrument cluster lighting (▷ page 268)

Instrument cluster lighting

The lighting in the instrument cluster, in the displays and the controls in the vehicle interior can be adjusted using the brightness control knob.

The brightness control knob is on the bottom left of the instrument cluster (▷ page 30).

- ▶ Turn the brightness control knob clockwise or anti-clockwise.

If the light switch is set to **AUTO**,  or , the brightness is dependant upon the brightness of the ambient light.

- i** The light sensor in the instrument cluster automatically controls the brightness of the multifunction display.

In daylight, the displays in the instrument cluster are not illuminated.

Coolant temperature gauge

The coolant temperature gauge is in the instrument cluster on the right-hand side (▷ page 30).

Under normal operating conditions and with the specified coolant level, the coolant temperature may rise to 120 °C.

At high outside temperatures and when driving uphill, the coolant temperature may rise to the end of the scale.

Rev counter

- !** Do not drive in the overrevving range. Doing so will damage the engine.

The red band in the rev counter indicates the engine's overrevving range.

The fuel supply is interrupted to protect the engine when the red band is reached.

Outside temperature display

WARNING

At temperatures just above freezing point, the street may be icy, especially in wooded areas or on bridges. If you do not adapt your driving style to the conditions, the vehicle could skid. For this reason, adapt your driving style and speed to the weather conditions.

The outside temperature display is in the multifunction display (▷ page 270).

Changes in the outside temperature are displayed after a short delay.

Speedometer with segments

The segments in the speedometer indicate which speed range is available.

- Cruise control activated (▷ page 193):
The segments light up from the stored speed to the maximum speed.
- Variable SPEEDTRONIC activated (▷ page 196):
The segments light up from the start of the scale to the selected limit speed.
- DISTRONIC PLUS activated (▷ page 198):
One or two segments in the set speed range light up.
- DISTRONIC PLUS detects a vehicle in front:
The segments between the speed of the vehicle in front and the stored speed light up.

Operating the on-board computer

Overview









- ① Multifunction display
- ② Switches on LINGUATRONIC; see the separate operating instructions
- ③ Right control panel
- ④ Left control panel
- ⑤ Back button



► **To activate the on-board computer:** turn the key to position **1** in the ignition lock.

You can control the multifunction display and the settings in the on-board computer using the buttons on the multifunction steering wheel.

Left control panel

	• Calls up the menu and menu bar
	
	Press briefly:
	<ul style="list-style-type: none"> • Scrolls through lists • Selects a submenu or function • In the Audio menu: selects a stored station, an audio track or a video scene • In the Te1 (telephone) menu: switches to the phone book and selects a name or telephone number
	Press and hold:
	<ul style="list-style-type: none"> • In the Audio menu: selects the previous/next station or selects an audio track or a video scene using rapid scrolling • In the Te1 (Telephone) menu: starts rapid scrolling if the phone book is open
	<ul style="list-style-type: none"> • Confirms selection/display message • In the Te1 (telephone) menu: switches to the telephone book and starts dialling the selected number • In the Audio menu: stops the station search function at the desired station

Right control panel

	<ul style="list-style-type: none"> • Rejects or ends a call • Exits telephone book/redial memory
	<ul style="list-style-type: none"> • Makes or accepts a call • Switches to the redial memory



- Adjusts the volume



- Mute

Back button



Press briefly:

- Back
- Switches off LINGUATRONIC; see the separate operating instructions
- Hides display messages/calls up the last Trip menu function used
- Exits the telephone book/redial memory



Press and hold:

- Calls up the standard display in the Trip menu

Multifunction display



- ① Time
- ② Permanent display: outside temperature or speed (▷ page 280)
- ③ Description field
- ④ Menu bar

- ⑤ Drive program (▷ page 168)
- ⑥ Transmission position (▷ page 168)

► **To show menu bar ④:** press the ◀ or ▶ button on the steering wheel.

Menu bar ④ disappears after a few seconds. Text field ③ shows the selected menu or submenu as well as display messages.

i You can set the time using the audio system or COMAND Online; see the separate operating instructions.

The following messages can appear in the multifunction display:



Active Parking Assist
(▷ page 219)



Cruise control (▷ page 193)



SPEEDTRONIC (▷ page 196)



DSR (▷ page 251)



Off-road program (vehicles without the ON&OFFROAD package)
(▷ page 252)



Off-road program (vehicles with the ON&OFFROAD package)
(▷ page 253)



LOW RANGE off-road gear
(▷ page 254)



Adaptive Main-beam Assist
(▷ page 125)



ATTENTION ASSIST
(▷ page 232)



ECO start/stop function
(▷ page 163)



Speed Limit Assist
(▷ page 233)



Lane Keeping Assist
(▷ page 240)



Active Lane Keeping Assist
(▷ page 245)



HOLD function (▷ page 211)



Distance warning function
(▷ page 63)



PRE-SAFE® Brake (▷ page 68)

120 km/h! Maximum permissible speed exceeded (only for certain countries) (▷ page 68)

Menus and submenus

Menu overview

Press the or button on the steering wheel to call up the menu bar and select a menu.

Operating the on-board computer (▷ page 269).

Depending on the equipment fitted in the vehicle, you can call up the following menus:

- **Trip** menu (▷ page 271)
- **Navi** menu (navigation details) (▷ page 272)
- **Audio** menu (▷ page 274)
- **Tel** menu (telephone) (▷ page 275)
- **Assist.** menu (assistance) (▷ page 277)
- **Serv.** menu (▷ page 279)
- **Sett.** menu (▷ page 279)
- **ON&OFFROAD** menu (▷ page 286)
- **AMG** menu in AMG vehicles (▷ page 286)

The **Audio**, **Navi** and **Tel** menus differ slightly in vehicles with an audio system and in vehicles with COMAND Online. The examples given in this Owner's Manual apply to vehicles equipped with COMAND Online.

Trip menu

Standard display



- ▶ Press and hold the button on the steering wheel until the **Trip** menu with trip meter ① and total distance recorder ② is shown.

Trip computer "From start" or "From reset"



Example: "From start" trip computer

- ① Distance
- ② Time
- ③ Average speed
- ④ Average fuel consumption

- ▶ Press the or button on the steering wheel to select the **Trip** menu.
- ▶ Press or to select **From start** or **From reset**.

The values in the **From start** submenu are calculated from the start of a journey, whilst the values in the **From reset** submenu are calculated from the last time the submenu was reset (▷ page 272).

The **From start** trip computer is automatically reset when:

- the ignition has been switched off for more than four hours.
- 999 hours have been exceeded.
- 9,999 kilometres have been exceeded.

The **From reset** trip computer is automatically reset if the value exceeds 9,999 hours or 99,999 kilometres.

Displaying the range and current fuel consumption

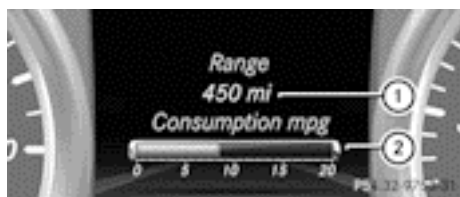

- ① Approximate range
 - ② Current fuel consumption (not for AMG vehicles)
- ▶ Press the or button on the steering wheel to select the **Trip** menu.
 - ▶ Press the or button to select the current fuel consumption (not for AMG vehicles) and the approximate range.

The approximate range which can be covered depends on the fuel level and your current driving style. If there is only a small amount of fuel left in the fuel tank, the display shows a vehicle being refuelled instead of the range.

Digital speedometer

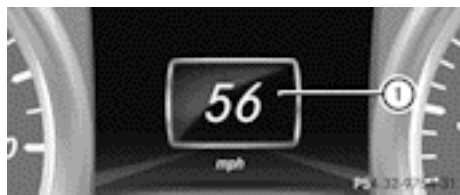

- ① Digital speedometer
- ▶ Press the or button on the steering wheel to select the **Trip** menu.
 - ▶ Press the or button to select the digital speedometer.

Resetting values



Example: resetting the trip computer "From start"

- ▶ Press the or button on the steering wheel to select the **Trip** menu.
- ▶ Press the or button to select the function that you wish to reset.
- ▶ Press the button.
- ▶ Press the button to select **Yes** and press the button to confirm.

You can reset the values of the following functions:

- trip meter
- trip computer "From start"
- trip computer "From reset"

Navigation menu

Displaying navigation instructions

In the **Nav**i menu, the multifunction display shows navigation instructions.

For more information, see the separate operating instructions.

- ▶ Switch on the audio system with Becker® MAP PILOT or COMAND Online; see the separate operating instructions.
- ▶ Press the or button on the steering wheel to select the **Nav**i menu.

Route guidance not active

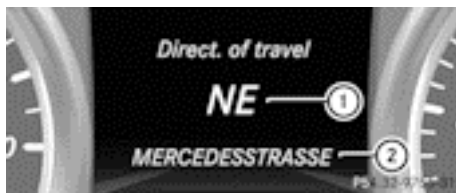

- ① Direction of travel
- ② Current street

Activated route guidance

No change of direction announced



- ① Distance to the destination
- ② Distance to the next change of direction
- ③ Current street
- ④ Symbol "follow the road's course"

Change of direction announced without a lane recommendation



- ① Road to which the change of direction leads
- ② Distance to change of direction and visual distance display
- ③ Change-of-direction icon

When a change of direction has been announced, you will see visual distance display ② next to the symbol for change of direction ③. This shortens from the bottom

to the top of the display as you approach the point of the announced change of direction.

Change of direction announced with a lane recommendation

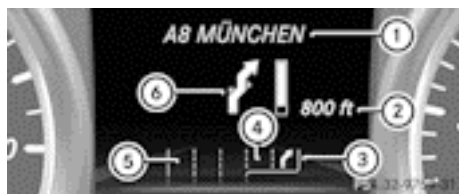

- ① Road to which the change of direction leads
- ② Distance to change of direction and visual distance display
- ③ Lane recommendation
- ④ New lane during a change of direction
- ⑤ Lane continues through change of direction
- ⑥ Change-of-direction icon

On multilane roads, the system can display lane recommendation ③ for the next change of direction. During the change of direction, additional lanes may be displayed.

Lane recommendations are only displayed if the relevant data is available on the digital map.

Other status indicators of the navigation system

-  : you have reached the destination or an intermediate destination.
- **New route...** or **Calculating route:** calculating a new route
- **Off map** or **Off road:** the vehicle position is outside the area of the digital map (off-map position).
- **No route:** no route could be calculated to the selected destination.

Audio menu

Selecting a radio station



- ① Waveband
- ② Channel frequency with memory position

i Station ② is displayed with the station frequency or station name. The memory position is only displayed along with station ② if this has been stored.

- ▶ Switch on the audio system or COMAND Online and select Radio; see the separate operating instructions.
- ▶ Press the or button on the steering wheel to select the **Audio** menu.
- ▶ **To select a stored station:** briefly press the or button.
- ▶ **To select a station from the station list:** press and briefly hold the or button.

If no station list is received:

- ▶ **To select a station using the station search:** press and briefly hold the or button.
- i** For information on switching waveband and storing stations; see the separate operating instructions.
- i** DAB radio mode (**D**igital **A**udio **B**roadcasting); see the separate operating instructions.

Audio player or audio media operation



Example: CD/DVD changer display

- ① Current CD in the CD/DVD changer
- ② Current track

Audio data from various audio devices or media can be played, depending on the equipment fitted in the vehicle.

- ▶ Switch on the audio system or COMAND Online and activate audio CD/DVD mode or MP3 mode; see the separate operating instructions.
- ▶ Press the or button on the steering wheel to select the **Audio** menu.
- ▶ **To select the next/previous track:** briefly press the or button.
- ▶ **To select a track from the track list (rapid scrolling):** press and hold the or button until desired track ② has been reached.

If you press and hold or , the rapid scrolling speed is increased. Not all audio devices or media support this function.

If track information is stored on the audio device or medium, the multifunction display will show the number and title of the track. The current track does not appear in audio AUX mode (**A**uxiliary audio mode: external audio source connected).

Video DVD operation



Example: CD/DVD changer display

- ① Current DVD in the CD/DVD changer
- ② Current scene

- ▶ Switch on the audio system or COMAND Online and select video DVD; see the separate operating instructions.
- ▶ Press the ◀ or ▶ button on the steering wheel to select the **Audio** menu.
- ▶ **To select the next/previous scene:** briefly press the ▲ or ▼ button.
- ▶ **To select a scene from the scene list (rapid scrolling):** press and hold the ▲ or ▼ button until desired scene ② has been reached.

TV operation



- ① Function
- ② Channel frequency with memory position

- ❗ The memory position is only displayed with station ② if this has been stored.
- ▶ Switch on COMAND Online and select TV; see the separate operating instructions.
- ▶ Press the ◀ or ▶ button on the steering wheel to select the **Audio** menu.

- ▶ **To select a stored station:** briefly press the ▲ or ▼ button.

- ▶ **To select a station from the station list:** press and briefly hold the ▲ or ▼ button.

- ❗ Storing a TV channel; see the separate operating instructions.
- ❗ Depending on the digital TV broadcaster, radio stations can also be received. The multifunction display shows **TV (RADIO)**.

Telephone menu

Introduction

⚠ WARNING

Observe the legal requirements of the country in which you are currently driving regarding the use of mobile phones in the vehicle.

If it is permitted to use mobile phones while the vehicle is in motion, you should only use them when the road and traffic conditions allow. Otherwise, you may be distracted from the traffic conditions, cause an accident and injure yourself and others.

- ▶ Switch on the mobile phone (see the separate operating instructions).
- ▶ Switch on the audio system or COMAND Online; see the separate operating instructions.
- ▶ Insert the mobile phone into the mobile phone bracket (see the separate installation instructions for the mobile phone fitting).
- or
- ▶ Establish a Bluetooth® connection to the audio system or COMAND Online; see the separate operating instructions.
- ▶ Press the ◀ or ▶ button on the steering wheel to select the **Te1** menu.

You will see one of the following display messages in the multifunction display:

- **Please enter PIN:** the mobile phone has been placed in the mobile phone bracket and the PIN has not yet been entered. When you enter your PIN via the mobile phone, LINGUATRONIC, the audio system or COMAND Online, the mobile phone searches for a network.
 - **Telephone ready** or the name of the network provider: the mobile phone has found a network and is ready to receive.
 - **Telephone No Service:** there is no network available or the mobile phone is searching for a network.
- i** You can obtain further information about suitable mobile phones and connecting mobile phones via Bluetooth®:
- from any Mercedes-Benz Service Centre
 - on the Internet at: <http://www.mercedes-benz.com/connect>

Accepting a call



Example: incoming call

If someone calls you when you are in the **Te1** menu, a display message appears in the multifunction display.

- ▶ Press the  button on the steering wheel to accept an incoming call.







You can accept a call even if you are not in the **Te1** menu.

Rejecting or ending a call





- ▶ Press the  button on the steering wheel.

You can end or reject a call even if you are not in the **Te1** menu.







Dialling a number from the phone book

- ▶ Press the  or  button on the steering wheel to select the **Te1** menu.
- ▶ Press the ,  or  button to switch to the phone book.
- ▶ Press the  or  button to select the desired name.



or

- ▶ **To begin rapid scrolling:** press and hold the  or  button for longer than one second. Rapid scrolling stops when you release the button or reach the end of the list.
- ▶ **If only one telephone number is stored for a name:** press the  or  button to start dialling.

or





- ▶ **If there is more than one number for a particular name:** press the  or  button to display the numbers.
- ▶ Press the  or  button to select the number you want to dial.
- ▶ Press the  or  button to start dialling.

or

- ▶ **To exit the telephone book:** press the  or  button.

Redialling

The on-board computer saves the last names or numbers dialled in the redial memory.

- ▶ Press the  or  button on the steering wheel to select the **Te1** menu.
- ▶ Press the  button to switch to the redial memory.
- ▶ Press the  or  button to select the desired name or number.

- ▶ Press the  or  button to start dialing.

or

- ▶ **To exit the redial memory:** press the  or  button.

Assistance menu

Introduction







In the **Assist.** menu, you have the following options:







- showing Speed Limit Assist and activating/deactivating its message function (▷ page 277)
- showing the distance display (▷ page 277)
- activating/deactivating the distance warning function (▷ page 278)
- activating/deactivating PRE-SAFE® Brake (▷ page 278)
- activating/deactivating ATTENTION ASSIST (▷ page 278)
- activating/deactivating Blind Spot Assist or Active Blind Spot Assist (▷ page 279)
- activating/deactivating Lane Keeping Assist or Active Lane Keeping Assist (▷ page 279)

Speed Limit Assist

Displaying Speed Limit Assist

- ▶ Press  or  on the steering wheel to select the **Assist.** menu.
- ▶ Press the  or  button to select **Speed Lim. Asst..**
- ▶ Press the  button.
Under certain conditions, detected speed limits are shown in the multifunction display (▷ page 233).





Activating/deactivating the Speed Limit Assist message function

- ▶ Press  or  on the steering wheel to select the **Assist.** menu.
- ▶ Press the  or  button to select **Speed Lim. Asst..**
- ▶ Press the  button.
The multifunction display shows Speed Limit Assist.
- ▶ Press the  button.
The current selection is displayed.
- ▶ **To activate or deactivate:** press .

If the Speed Limit Assist message function is activated, a detected speed limit is automatically displayed for five seconds. Other items in the multifunction display are not shown during this time.

If Speed Limit Assist is operational and the message function is activated, the multifunction display shows the  symbol when the ignition is switched on.







Showing the distance display

- ▶ Press  or  on the steering wheel to select the **Assist.** menu.
- ▶ Press the  or  button to select **Distance display.**
- ▶ Press the  button.
The DISTRONIC PLUS distance display appears in the multifunction display (▷ page 205).



If the **Sensors deactivated** message appears, the radar sensor system is deactivated.

- ▶ Check whether or not the radar sensor system is permitted to be activated (▷ page 433).
- ▶ Switch on the radar sensor system (▷ page 283).

Activating/deactivating distance warning function

- ▶ Press  or  on the steering wheel to select the **Assist.** menu.
- ▶ Press  or  to select **Dist. warn- ing.**
- ▶ Press the  button.
The current selection is displayed.
- ▶ **To activate/deactivate:** press the  button again.





When the distance warning function is activated, the multifunction display shows the  symbol if the HOLD function is not activated (▷ page 211).



Vehicles with Active Parking Assist: if PARKTRONIC is activated and you are driving at a speed under 35 km/h, the  Active Parking Assist symbol is shown instead of the  symbol (▷ page 219).

Further information on the distance warning function (▷ page 63).



Activating/deactivating PRE-SAFE® Brake

PRE-SAFE® Brake is only available in vehicles with DISTRONIC PLUS.

- ▶ Press  or  on the steering wheel to select the **Assist.** menu.
- ▶ Press the  or  button to select **PRE-SAFE Brake.**

- ▶ Press the  button.
The current selection is displayed.
- ▶ **To activate/deactivate:** press the  button again.

When PRE-SAFE® Brake is activated, the multifunction display shows the  symbol as long as the HOLD function is not activated (▷ page 211).







Vehicles with Active Parking Assist: if PARKTRONIC is activated and you are driving at a speed under 35 km/h, the  Active Parking Assist symbol is shown instead of the  symbol (▷ page 219).

If the **PRE-SAFE Brake: Sensors deactivated** message appears, the radar sensor system is deactivated.

- ▶ Check whether or not the radar sensor system is permitted to be activated (▷ page 433).
- ▶ Switch on the radar sensor system (▷ page 283).

For more information on PRE-SAFE® Brake, see (▷ page 68).







Activating/deactivating ATTENTION ASSIST

- ▶ Press  or  on the steering wheel to select the **Assist.** menu.
- ▶ Press the  or  button to select **Attention Asst.**
- ▶ Press the  button.
The current selection is displayed.
- ▶ **To activate/deactivate:** press the  button again.

When ATTENTION ASSIST is activated, the  symbol appears in the multifunction display when the ignition is on.

For further information about ATTENTION ASSIST, see (▷ page 232).

Activating/deactivating Blind Spot Assist

- ▶ Press  or  on the steering wheel to select the **Assist.** menu.
- ▶ Press the  or  button to select **Blind Spot Asst..**
- ▶ Press the  button.
The current selection is displayed.
- ▶ **To activate/deactivate:** press the  button again.









If the **Blind Spot Assist Sensors deactivated** or **Active blind spot assist. sensor system deactivated** message appears, the radar sensor system is deactivated.

- ▶ Check whether or not the radar sensor system is permitted to be activated (▷ page 433).
- ▶ Switch on the radar sensor system (▷ page 283).

For further information about Blind Spot Assist, see (▷ page 238).

For further information about Active Blind Spot Assist, see (▷ page 242).

Activating/deactivating Lane Keeping Assist

- ▶ Press  or  on the steering wheel to select the **Assist.** menu.
- ▶ Press the  or  button to select **Lane Keep. Asst.**
- ▶ Press the  button.
The current selection is displayed.
- ▶ Press  to confirm.
- ▶ Press  or  to set **Off**, **Standard** or **Adaptive**.
- ▶ Press the  button to save the setting.

When Lane Keeping Assist or Active Lane Keeping Assist is activated, the  symbol appears in the multifunction display when the ignition is on.

For further information about Lane Keeping Assist, see (▷ page 240).

For further information about Active Lane Keeping Assist, see (▷ page 245).

Service menu



In the **Serv.** menu, you have the following options:

- call up display messages in message memory (▷ page 290)
- restart the tyre pressure loss warning system (▷ page 401)
- check the tyre pressure electronically (▷ page 402)
- call up service due date (▷ page 365)

Settings menu

Introduction



In the **Settings** menu, you have the following options:

- changing the instrument cluster settings (▷ page 280)
- changing the light settings (▷ page 280)
- changing the vehicle settings (▷ page 283)
- changing the auxiliary heating settings (▷ page 284)









- changing the convenience settings (▷ page 285)
- restoring the factory settings (▷ page 286)

Instrument cluster submenu

Selecting the unit of measurement for distance

The **Display unit Speed-/odometer:** function allows you to choose whether certain displays appear in kilometres or miles in the multifunction display.

You can determine whether the multifunction display shows some messages in miles or kilometres.









- ▶ Press the  or  button on the steering wheel to select the **Settings** menu.
- ▶ Press the  or  button to select the **Inst. cluster** submenu.
- ▶ Press  to confirm.
- ▶ Press the  or  button to select the **Display unit Speed-/odometer:** function.
You will see the selected setting: **km** or **miles**.
- ▶ Press the  button to save the setting.

The selected unit of measurement for distance applies to:

- the digital speedometer in the **Trip** menu
- the total distance recorder and the trip meter
- the trip computer
- the current consumption and the range
- the navigation instructions in the **Navi** menu
- cruise control
- SPEEDTRONIC
- DISTRONIC PLUS
- ASSYST PLUS service interval display

Selecting the permanent display function

You can determine whether the multifunction display permanently shows your speed or the outside temperature.

- ▶ Press the  or  button on the steering wheel to select the **Settings** menu.
- ▶ Press the  or  button to select the **Inst. cluster** submenu.
- ▶ Press  to confirm.
- ▶ Press the  or  button to select the **Permanent display:** function.
You will see the selected setting: **outside temperature** or **Dig. speedo [mph]**.
- ▶ Press the  button to save the setting.









i Speed is displayed in mph.

i Vehicles for the United Kingdom: this function is unavailable.

Light submenu









Setting the daytime driving lights

The **Daytime driving lights** function can only be switched on while the engine is switched off.

- ▶ Press the  or  button on the steering wheel to select the **Settings** menu.
- ▶ Press the  or  button to select the **Light** submenu.
- ▶ Press  to confirm.
- ▶ Press  or  to select the **Daytime driving lights** function.
If the **Daytime driving lights** have been switched on, the cone of light and the  symbol in the multifunction display are shown in red.
- ▶ Press the  button to save the setting.

Further information on daytime driving lights (▷ page 119).

Switching the Intelligent Light System on/off

- ▶ Press the  or  button on the steering wheel to select the **Settings** menu.
- ▶ Press the  or  button to select the **Light** submenu.
- ▶ Press  to confirm.
- ▶ Press  or  to select the **Intell. Light System** function.
If the **Intell. Light System** function has been switched on, the cone of light and the  symbol in the multifunction display are shown in red.
- ▶ Press the  button to save the setting.





When you activate **Intell. Light System**, you activate the following functions:



- motorway mode
- active light function
- cornering light function
- extended range foglamps
- off-road lights

If you set the dipped-beam headlamps for driving on the right/left, the multifunction display shows the **Intell. Light System: system inoperative Inactive for left-side traffic** or **Intell. Light System: System inoperative Inactive for right-side traffic** (▷ page 281) display message instead of the **Intell. Light System** function in the **Light** submenu.

Further information on the Intelligent Light System (▷ page 123).

Setting the dipped-beam headlamps for driving on the left/right

- ▶ Press the  or  button on the steering wheel to select the **Settings** menu.
- ▶ Press the  or  button to select the **Light** submenu.
- ▶ Press  to confirm.

- ▶ Press the  or  button to select the **Dipped beams Setting for:** function.
You will see the selected setting: **Right-side traffic** or **Left-side traffic**.
- ▶ Press the  button to save the setting.
When you change the setting, conversion does not take place until the next time the vehicle is stationary.









This function is only available on vehicles with the Intelligent Light System.

You can use this function to switch between symmetrical and asymmetrical dipped beam (▷ page 118).

If you set the dipped-beam headlamps for driving on the right/left, then motorway mode and the extended range foglamps are unavailable.





You can have the dipped-beam headlamps set for driving on the right or left at a qualified specialist workshop.

Switching Adaptive Highbeam Assist on/off

- ▶ Press the  or  button on the steering wheel to select the **Settings** menu.
- ▶ Press the  or  button to select the **Light** submenu.
- ▶ Press  to confirm.
- ▶ Press the  or  button to select the **Adapt. main beam** function.
If the **Adapt. main beam** function has been switched on, the cone of light and the  symbol in the upper multifunction display are shown in red.
- ▶ Press the  button to save the setting.

For further information about Adaptive Highbeam Assist, see (▷ page 125).

Setting the brightness of the ambient lighting

- ▶ Press the  or  button on the steering wheel to select the **Settings** menu.
- ▶ Press the  or  button to select the **Light** submenu.

- ▶ Press **OK** to confirm.
- ▶ Press the **▼** or **▲** button to select the **Amb. light +/-** function. You will see the selected setting.
- ▶ Press **OK** to confirm.
- ▶ Press the **▼** or **▲** button to adjust the brightness to any level from **Off** to **Level 5** (bright).
- ▶ Press the **OK** or **↩** button to save the setting.

Setting the ambient lighting colour

- ▶ Press the **◀** or **▶** button on the steering wheel to select the **Settings** menu.
- ▶ Press the **▼** or **▲** button to select the **Light** submenu.
- ▶ Press **OK** to confirm.
- ▶ Press the **▼** or **▲** button to select the **Ambient light colour** function.
- ▶ Press **OK** to confirm.
- ▶ Press the **▼** or **▲** button to set the colour to **SOLAR**, **NEUTRAL** or **POLAR**.
- ▶ Press the **OK** or **↩** button to save the setting.

Surround lighting and exterior lighting delayed switch-off

- ▶ Press the **◀** or **▶** button on the steering wheel to select the **Settings** menu.
- ▶ Press the **▼** or **▲** button to select the **Light** submenu.
- ▶ Press **OK** to confirm.
- ▶ Press **▼** or **▲** to select the **Surround Lighting** function. When the **Surround lighting** function is activated, the light cone and the area around the vehicle are displayed in red in the multifunction display.
- ▶ Press the **OK** button to save the setting.

Deactivating delayed switch-off of the exterior lighting temporarily:

- ▶ Before leaving the vehicle, turn the key to position **0** in the ignition lock.
- ▶ Turn the key to position **2** in the ignition lock. The exterior lighting delayed switch-off is deactivated.

Delayed switch-off of the exterior lighting is reactivated the next time you start the engine.

If you have activated the **Surround lighting** function and the light switch is set to **AUTO**, the following functions are activated when it is dark:









- **Surround lighting:** the exterior lighting remains lit for 40 seconds after unlocking with the key. If you start the engine, the surround lighting is switched off and the automatic headlamp mode is activated (▷ page 119).
- **Exterior lighting delayed switch-off:** the exterior lighting remains lit for 60 seconds after the engine is switched off. If you close all the doors and the tailgate, the exterior lighting goes off after 5 seconds.

i Depending on your vehicle's equipment, when the surround lighting and delayed switch-off exterior lighting are on, the following light up:

- side lamps
- daytime driving lights
- surround lighting in the exterior mirrors











Activating/deactivating the interior lighting delayed switch-off

If you activate the **Lighting delayed sw.-off** function, the interior lighting remains on for 20seconds after you remove the key from the ignition lock.

- ▶ Press the  or  button on the steering wheel to select the **Settings** menu.
- ▶ Press the  or  button to select the **Light** submenu.
- ▶ Press  to confirm.
- ▶ Press  or  to select the **Lighting delayed sw.-off** function.
When the **Lighting delayed sw.-off** function is activated, the vehicle interior is displayed in red in the multifunction display.
- ▶ Press the  button to save the setting.

Vehicle submenu





Setting permanent SPEEDTRONIC





- ▶ Press the  or  button on the steering wheel to select the **Settings** menu.
- ▶ Press  or  to select the **Vehicle** submenu.
- ▶ Press  to confirm.
- ▶ Press the  or  button to select the **Limit speed (winter tyres):** function.
You will see the current setting.
- ▶ Press  to confirm.
- ▶ Press the  or  button to adjust permanent SPEEDTRONIC in increments of ten (230 km/h to 160 km/h). The **Off** setting switches permanent SPEEDTRONIC off.
- ▶ Press the  button to store the entry.

For further information on permanent SPEEDTRONIC (> page 198).

Switching the automatic locking feature on/off

If you activate the **Automatic door locks** function, the vehicle is centrally locked above a speed of around 15 km/h.









- ▶ Press the  or  button on the steering wheel to select the **Settings** menu.
- ▶ Press  or  to select the **Vehicle** submenu.

- ▶ Press  to confirm.
- ▶ Press  or  to select the **Automatic door locks** function.
When the **Automatic door locks** function is activated, the vehicle doors are displayed in red in the multifunction display.
- ▶ Press the  button to save the setting.









For further information on the automatic locking feature, see (> page 84).

Activating/deactivating the acoustic locking confirmation

If you switch on the **Acoustic Lock** function, an acoustic signal sounds when you lock the vehicle.

- ▶ Press the  or  button on the steering wheel to select the **Settings** menu.
- ▶ Press  or  to select the **Vehicle** submenu.
- ▶ Press  to confirm.
- ▶ Press the  or  button to select the **Acoustic Lock** function.
If the **Acoustic Lock** function is activated, the  symbol in the multifunction display lights up red.
- ▶ Press the  button to save the setting.

Activating/deactivating the radar sensor system

- ▶ Press the  or  button on the steering wheel to select the **Settings** menu.
- ▶ Press  or  to select the **Vehicle** submenu.
- ▶ Press  to confirm.
- ▶ Press the  or  button to select **Radar sensor (See Owner's Man.):**.
You will see the selected setting: **on** or **off**.
- ▶ Press the  button to save the setting.

- ▶ **i** You must deactivate the radar sensor system in certain countries and near radio telescope facilities. For further information, see (> page 433).

When you are close to radio telescope facilities, the radar sensor system will be deactivated automatically.

The following systems are switched off when the radar sensor system is deactivated:

- DISTRONIC PLUS (▷ page 198)
- BAS PLUS (▷ page 62)
- PRE-SAFE® Brake (▷ page 68)
- Blind Spot Assist (▷ page 238)
- Active Blind Spot Assist (▷ page 242)

Heating submenu

Auxiliary heating departure time

WARNING

Exhaust fumes are produced when the auxiliary heating is in operation. Inhaling these exhaust fumes can be poisonous. You should therefore switch off the auxiliary heating in confined spaces without an extraction system, e.g. a garage.

WARNING

When operating the auxiliary heating parts of the vehicle can get very hot. Make sure that the exhaust system does not under any circumstances come into contact with easily ignitable material such as dry grass or fuels. The material could otherwise ignite and set the vehicle alight. Choose your parking spot accordingly.

Operating the auxiliary heating is thus prohibited at filling stations or when your vehicle is being refuelled. You must therefore switch off the auxiliary heating at filling stations.

 Operating the auxiliary heating/ventilation draws on the vehicle battery. After you have heated or ventilated the vehicle a maximum of two times, drive for a longer distance.

This function is only available on vehicles with auxiliary heating (▷ page 148).









In the **Heating** submenu, you can select a stored departure time or change a departure time.

The auxiliary heating timer function calculates the switch-on time according to the outside temperature so that the vehicle is preheated by the departure time. When the departure time is reached, the auxiliary heating continues to heat for a further five minutes and then switches off. The auxiliary heating adopts the THERMATIC or THERMOTRONIC temperature setting.







You can switch off the auxiliary heating by using the remote control or the auxiliary heating button on the centre console.









-  Switch the auxiliary heating on regularly once a month for about ten minutes.

Selecting the departure time or deactivating a selected departure time

- ▶ Press the  or  button on the steering wheel to select the **Settings** menu.
- ▶ Press the  or  button to select the **Heating** submenu.
- ▶ Press  to confirm.
You will see the selected setting.
- ▶ Press  to confirm.
- ▶ Press the  or  button to select one of the three departure times or **Timer off** (no timer active).
- ▶ Press  to confirm.
If a departure time is selected, the yellow indicator lamp lights up on the auxiliary heating button.

Changing the departure time

- ▶ Press the  or  button on the steering wheel to select the **Settings** menu.
- ▶ Press the  or  button to select the **Heating** submenu.
- ▶ Press  to confirm.
You will see the selected setting.
- ▶ Press  to confirm.

- ▶ Press the  or  button to select **A**, **B** or **Change C**.
- ▶ Press  to confirm.
You can now change the departure time.
- ▶ Press the  or  button to select the display to be changed: hours, minutes.
- ▶ Press the  or  button to set the selected display.
- ▶ Press the  button to store the entry.
The yellow indicator lamp on the auxiliary heating button lights up.









Convenience submenu

Activating/deactivating the EASY-ENTRY/EXIT feature

WARNING









The steering wheel moves when the EASY-ENTRY/EXIT feature is active. There is a risk of occupants becoming trapped. Before activating the EASY-ENTRY/EXIT feature, make sure that nobody can become trapped.

Do not leave children unsupervised in the vehicle, even if they are secured in a child restraint system. The children could open the driver's door and thereby unintentionally activate the EASY-ENTRY/EXIT feature and become trapped.

- ▶ Press the  or  button on the steering wheel to select the **Settings** menu.
- ▶ Press the  or  button to select the **Convenience** submenu.
- ▶ Press  to confirm.
- ▶ Press  or  to select the **Easy Entry/Exit** function.
If the **Easy Entry/Exit** function is activated, the vehicle steering wheel is displayed in red in the multifunction display.
- ▶ Press the  button to save the setting.

Further information on the EASY-ENTRY/EXIT feature (▷ page 111).

Switching the belt adjustment on/off









- ▶ Press the  or  button on the steering wheel to select the **Settings** menu.
- ▶ Press the  or  button to select the **Convenience** submenu.
- ▶ Press  to confirm.
- ▶ Press the  or  button to select the **Belt adjustment** function.
When the **Belt adjustment** function is activated, the vehicle seat belt is displayed in red in the multifunction display.
- ▶ Press the  button to save the setting.

For further information on belt adjustment, see (▷ page 48).

Switching the Fold in mirrors when locking function on/off

This function is only available on vehicles with Memory Function (▷ page 115).

When you activate the **Auto. fold-in mirrors** function, the exterior mirrors are folded in when the vehicle is locked. When you unlock the vehicle and then open a door, the exterior mirrors fold out again.

- ▶ Press the  or  button on the steering wheel to select the **Settings** menu.
- ▶ Press the  or  button to select the **Convenience** submenu.
- ▶ Press  to confirm.
- ▶ Press  or  to select the **Auto. fold-in mirrors** function.
If the **Auto. fold-in mirrors** function is activated, the vehicle's exterior mirror is displayed in red in the multifunction display.
- ▶ Press the  button to save the setting.



① To fold the exterior mirrors in or out

If you have switched on the function and you fold the exterior mirrors in using button ①, the exterior mirrors do not fold out automatically (▷ page 113).

You can then only fold out the exterior mirrors using button ①.

Resetting to factory settings

- ▶ Press the ◀ or ▶ button on the steering wheel to select the **Settings** menu.
- ▶ Press the ▼ or ▲ button to select the **Factory setting** submenu.
- ▶ Press **OK** to confirm.
The **Reset all settings?** message appears.
- ▶ Press the ▼ or ▲ button to select **No** or **Yes**.
- ▶ Press **OK** to confirm the selection.
If you select **Yes**, the multifunction display shows a confirmation message.

For safety reasons, not all functions are reset: the **Limit speed (winter tyres)**: function in permanent SPEEDTRONIC can only be set in the **Vehicle** submenu. If you want to reset the **Daytime driving lights** in the **Light** submenu, you must turn the key to position **1** in the ignition lock.

ON&OFFROAD menu



Example: multifunction display

- ▶ Press the ◀ or ▶ button on the steering wheel to select the **ON&OFFROAD** menu.

You can set the following current settings to appear in the **ON&OFFROAD** menu:

- On-road program (▷ page 248)
- Off-road program (▷ page 253)

AMG menu in AMG vehicles

AMG displays

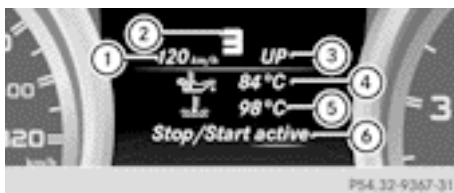

- ① Digital speedometer
- ② Gear indicator
- ③ Upshift indicator
- ④ Engine oil temperature
- ⑤ Coolant temperature
- ⑥ ECO start/stop function status indicator (▷ page 163)

- ▶ Press the ◀ or ▶ button on the steering wheel to select the **AMG** menu.

Upshift indicator **UP**③ indicates that the engine has reached the overrevving range when in the manual gearshift program. Upshift indicator **UP**③ fades out other messages until you have shifted up.

When the engine oil temperature is below 80 °C, the oil temperature is shown in blue.

Avoid using the full output of the engine during this time.

SETUP

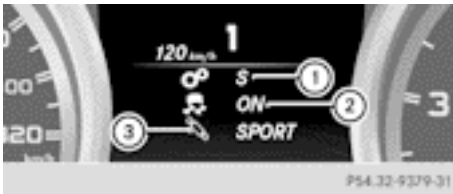

- ① Drive program (C/S/M)
- ② ESP® mode (ON/OFF)
- ③ Suspension tuning (COMFORT/SPORT/SPORT+)

SETUP shows the drive program, the ESP® (Electronic Stability Program) mode and the suspension tuning.

- ▶ Press the ◀ or ▶ button on the steering wheel to select the **AMG** menu.
- ▶ Press the ▲ button repeatedly until SETUP is displayed.

RACETIMER

Displaying and starting the RACETIMER

⚠ WARNING

The RACETIMER feature is only for use on roads and in conditions where high speed driving is permitted. Racing on public roads is prohibited under all circumstances. The driver is and must always remain responsible for following posted speed limits.



- ① Lap
- ② RACETIMER

You can start the RACETIMER when the engine is running or if the key is in position 2 in the ignition lock.

- ▶ Press the ◀ or ▶ button on the steering wheel to select the **AMG** menu.
- ▶ Press the ▲ button repeatedly until the RACETIMER is shown.
- ▶ **To start:** press the OK button to start the RACETIMER.

Displaying the intermediate time

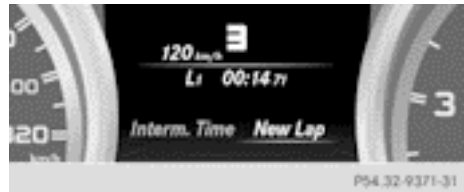

- ▶ Press the ◀ or ▶ button to select **Interm. Time**.
- ▶ Press OK to confirm.
The intermediate time is displayed for five seconds.

Starting a new lap

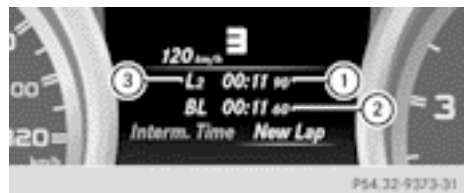

- ① RACETIMER
 - ② Fastest lap time (best lap)
 - ③ Lap
- ▶ Press OK to confirm **New Lap**.

i It is possible to store a maximum of sixteen laps. Lap 16 can only be stopped with **Finish Lap**.

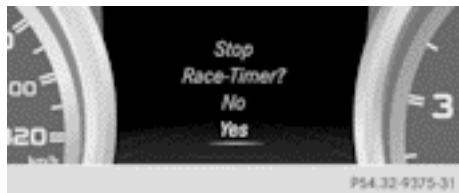

Stopping the RACETIMER



- ▶ Press the  button on the steering wheel.
- ▶ Press  to confirm **Yes**.

The RACETIMER interrupts timing when you stop the vehicle and turn the key to position **1** in the ignition lock. When you turn the key to position **2** or **3** and then press  to confirm **Start**, timing is continued.

Resetting the current lap



- ▶ Stop the RACETIMER.
- ▶ Press  or  to select **Reset Lap**.
- ▶ Press  to reset the lap time to "0".

Deleting all laps



If you switch off the engine, the RACETIMER is reset to "0" after 30 seconds. All laps are deleted.

You cannot delete individual stored laps. If you have stopped 16 laps, the current lap does not have to be reset.



- ▶ Reset the current lap.
- ▶ Press  to confirm **Reset**. **Reset Race Timer?** appears in the multi-function display.
- ▶ Press the  button to select **Yes** and press the  button to confirm. All laps are deleted.

Overall evaluation



- ① RACETIMER overall evaluation
- ② Total time driven
- ③ Average speed
- ④ Distance covered
- ⑤ Maximum speed

This function is shown if you have stored at least one lap and stopped the RACETIMER.



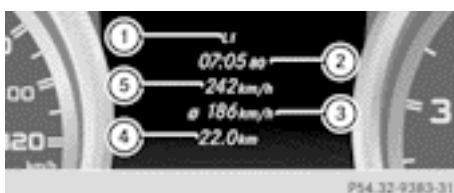

- ▶ Press the  or  button on the steering wheel to select the **AMG** menu.
- ▶ Press the  button repeatedly until the overall evaluation is shown.

Lap evaluation



- ① Lap
- ② Lap time
- ③ Average lap speed
- ④ Lap length
- ⑤ Top speed during lap

This function is only available if you have stored at least two laps and have stopped the RACETIMER.

- ▶ Press the  or  button on the steering wheel to select the AMG menu.
- ▶ Press the  button repeatedly until the lap evaluation is shown.
Each lap is shown in a separate submenu.
The fastest lap is indicated by flashing symbol ①.
- ▶ Press the  or  button to select a different lap evaluation.

Display messages

Introduction

General notes

Display messages appear in the multifunction display.

Display messages with graphic symbols are simplified in the Owner's Manual and may differ from the symbols in the multifunction display.



Please respond in accordance with the display messages and follow the additional notes in this Owner's Manual.

Certain display messages are accompanied by an audible warning tone or a continuous tone.

When you stop and park the vehicle, please observe the notes on:

- HOLD function (▷ page 211)
- Parking (▷ page 181)

Hiding display messages







- ▶ Press the  or  button on the steering wheel to hide the display message. The display message is cleared.

The multifunction display shows high-priority display messages in red. Some high-priority display messages cannot be hidden.











The multifunction display shows these messages continuously until the causes for the messages have been remedied.



Message memory









The on-board computer saves certain display messages in the **message memory**. You can call up the display messages:







- ▶ Press the  or  button on the steering wheel to select the **Serv.** menu. If there are display messages, the multifunction display shows **2 messages**, for example.
- ▶ Press the  or  button to select the entry, e.g. **2 messages**.
- ▶ Press  to confirm.
- ▶ Press the  or  button to scroll through the display messages.







When the ignition is switched off, all display messages are deleted apart from some high-priority display messages. Once the causes of the high-priority display messages have been rectified, the corresponding display messages are also deleted.











Safety systems	
Display messages	Possible causes/consequences and ► Solutions
  <p>currently unavailable See Owner's Manual</p>	<p>ABS (Anti-lock Braking System), ESP[®] (Electronic Stability Program), BAS (Brake Assist), PRE-SAFE[®], the HOLD function, hill start assist, crosswind driving assistance and ESP[®] trailer stabilisation are temporarily not available.</p> <p>The adaptive brake lights, COLLISION PREVENTION ASSIST, BAS PLUS and PRE-SAFE[®] Brake may also have failed.</p> <p>In addition, the ,  and  warning lamps light up in the instrument cluster.</p> <p>ATTENTION ASSIST is deactivated.</p> <p>Possible causes:</p> <ul style="list-style-type: none"> • self-diagnosis is not yet complete. • the on-board voltage may be insufficient. <p>⚠ WARNING</p> <p>The brake system continues to function normally, but without the functions listed above. The wheels could therefore lock if you brake hard, for example.</p> <p>The steerability and braking characteristics may be severely affected. The braking distance in an emergency braking situation can increase.</p> <p>If ESP[®] is not operational, ESP[®] is unable to stabilise the vehicle. The danger of skidding and having an accident increases.</p> <p>► Carefully drive on a suitable stretch of road, making slight steering movements at a speed above 20 km/h.</p> <p>If the display message disappears, the functions mentioned above are available again.</p> <p>If the display message continues to be displayed:</p> <ul style="list-style-type: none"> ► Drive on carefully. ► Visit a qualified specialist workshop.
  <p>inoperative See Owner's Manual</p>	<p>ABS, ESP[®], BAS, PRE-SAFE[®], the HOLD function, hill start assist, crosswind driving assistance and ESP[®] trailer stabilisation are not available due to a malfunction.</p> <p>The adaptive brake lights, COLLISION PREVENTION ASSIST, BAS PLUS and PRE-SAFE[®] Brake may also have failed.</p> <p>In addition, the , ,  and  warning lamps light up in the instrument cluster.</p> <p>ATTENTION ASSIST is deactivated.</p> <p>⚠ WARNING</p>

Display messages	Possible causes/consequences and ► Solutions
	<p>The brake system continues to function normally, but without the functions listed above. The wheels could therefore lock if you brake hard, for example.</p> <p>The steerability and braking characteristics may be severely affected. The braking distance in an emergency braking situation can increase.</p> <p>If ESP® is not operational, ESP® is unable to stabilise the vehicle. The danger of skidding and having an accident increases.</p> <ul style="list-style-type: none"> ► Drive on carefully. ► Visit a qualified specialist workshop immediately.
<div style="display: flex; align-items: center;">  <div style="margin-left: 10px;"> <p>currently unavailable See Owner's Manual</p> </div> </div>	<p>ESP®, BAS, PRE-SAFE®, the HOLD function, hill start assist, cross-wind driving assistance and ESP® trailer stabilisation are not available due to a malfunction.</p> <p>The adaptive brake lights, COLLISION PREVENTION ASSIST, BAS PLUS and PRE-SAFE® Brake may also have failed.</p> <p>In addition, the  and  warning lamps light up in the instrument cluster.</p> <p>The self-diagnosis function may not be complete, for example. ATTENTION ASSIST is deactivated.</p> <p>⚠ WARNING</p> <p>The brake system continues to function normally, but without the functions listed above. The wheels could therefore lock if you brake hard, for example.</p> <p>The braking distance in an emergency braking situation can thus increase.</p> <p>If ESP® is not operational, ESP® is unable to stabilise the vehicle. The danger of skidding and having an accident increases.</p> <ul style="list-style-type: none"> ► Carefully drive on a suitable stretch of road, making slight steering movements at a speed above 20 km/h. <p>If the display message disappears, the functions mentioned above are available again.</p> <p>If the display message continues to be displayed:</p> <ul style="list-style-type: none"> ► Drive on carefully. ► Visit a qualified specialist workshop.

Display messages	Possible causes/consequences and ► Solutions
 <p data-bbox="115 229 309 284">inoperative See Owner's Manual</p>	<p data-bbox="370 178 1037 264">ESP®, BAS, PRE-SAFE®, the HOLD function, hill start assist, crosswind driving assistance and ESP® trailer stabilisation are not available due to a malfunction.</p> <p data-bbox="370 276 1033 331">The adaptive brake lights, COLLISION PREVENTION ASSIST, BAS PLUS and PRE-SAFE® Brake may also have failed.</p> <p data-bbox="370 343 992 399">In addition, the  and  warning lamps light up in the instrument cluster.</p> <p data-bbox="370 410 725 432">ATTENTION ASSIST is deactivated.</p> <p data-bbox="381 451 535 480">▲ WARNING</p> <p data-bbox="370 496 1033 579">The brake system continues to function normally, but without the functions listed above. The wheels could therefore lock if you brake hard, for example.</p> <p data-bbox="370 590 1033 643">The braking distance in an emergency braking situation can thus increase.</p> <p data-bbox="370 654 1033 713">If ESP® is not operational, ESP® is unable to stabilise the vehicle. The danger of skidding and having an accident increases.</p> <ul data-bbox="370 724 766 786" style="list-style-type: none"> ► Drive on carefully. ► Visit a qualified specialist workshop.
   <p data-bbox="115 914 309 968">inoperative See Owner's Manual</p>	<p data-bbox="370 815 1033 932">EBD (electronic brake force distribution), ABS, ESP®, BAS, PRE-SAFE®, the HOLD function, hill start assist, crosswind driving assistance and ESP® trailer stabilisation are not available due to a malfunction.</p> <p data-bbox="370 943 1033 999">The adaptive brake lights, COLLISION PREVENTION ASSIST, BAS PLUS and PRE-SAFE® Brake may also have failed.</p> <p data-bbox="370 1010 1019 1066">In addition, the ,  and  warning lamps light up in the instrument cluster and a warning tone sounds.</p> <p data-bbox="370 1077 725 1099">ATTENTION ASSIST is deactivated.</p> <p data-bbox="381 1118 535 1147">▲ WARNING</p> <p data-bbox="370 1163 1033 1246">The brake system continues to function normally, but without the functions listed above. The wheels could therefore lock if you brake hard, for example.</p> <p data-bbox="370 1257 1033 1340">The steerability and braking characteristics may be severely affected. The braking distance in an emergency braking situation can increase.</p> <p data-bbox="370 1351 1033 1410">If ESP® is not operational, ESP® is unable to stabilise the vehicle. The danger of skidding and having an accident increases.</p> <ul data-bbox="370 1422 897 1484" style="list-style-type: none"> ► Drive on carefully. ► Visit a qualified specialist workshop immediately.







Display messages	Possible causes/consequences and ► Solutions
 Release parking brake	<p>The red  indicator lamp flashes and a warning tone sounds. A condition for automatic release of the electric parking brake is not fulfilled (▷ page 182).</p> <p>You are driving with the electric parking brake applied.</p> <p>► Release the electric parking brake manually.</p> <p>The red  indicator lamp flashes and a warning tone sounds. You are making an emergency stop using the electric parking brake (▷ page 182).</p>
 Parking brake See Owner's Manual	<p>The yellow  warning lamp lights up. The electric parking brake is malfunctioning.</p> <p>To apply:</p> <ul style="list-style-type: none"> ► Switch the ignition off. ► Press the electric parking brake handle for at least ten seconds. ► Move the transmission selector lever to P. ► Consult a qualified specialist workshop. <p>The yellow  warning lamp and the red  indicator lamp are lit. The electric parking brake is malfunctioning.</p> <p>To release:</p> <ul style="list-style-type: none"> ► Switch off the ignition and turn it back on. ► Release the electric parking brake manually. <p>or</p> <ul style="list-style-type: none"> ► Release the electric parking brake automatically (▷ page 182). <p>If the electric parking brake can still not be released:</p> <ul style="list-style-type: none"> ► Do not drive on. ► Consult a qualified specialist workshop.





Display messages	Possible causes/consequences and ► Solutions
	<p>The red  indicator lamp flashes and the yellow  warning lamp is lit.</p> <p>The electric parking brake is malfunctioning.</p> <p>To release:</p> <ul style="list-style-type: none"> ► Switch off the ignition and turn it back on. ► Release the electric parking brake manually. <p>To apply:</p> <ul style="list-style-type: none"> ► Switch off the ignition and turn it back on. ► Engage the electric parking brake manually. <p>If the red  indicator lamp continues to flash:</p> <ul style="list-style-type: none"> ► Do not drive on. ► Secure the vehicle against rolling away (▷ page 405). ► Move the transmission selector lever to P. ► Turn the front wheels towards the kerb. ► Consult a qualified specialist workshop.
	<p>The yellow  warning lamp lights up. The red  indicator lamp flashes for about ten seconds after the electric parking brake has been applied or released. It then goes out or remains lit.</p> <p>The electric parking brake is malfunctioning.</p> <ul style="list-style-type: none"> ► Switch off the ignition and turn it back on. ► Engage the electric parking brake. <p>If it is not possible to apply the electric parking brake:</p> <ul style="list-style-type: none"> ► Move the transmission selector lever to P. ► Visit a qualified specialist workshop. <p>If it is not possible to release the electric parking brake:</p> <ul style="list-style-type: none"> ► Release the electric parking brake automatically (▷ page 182). <p>If the electric parking brake can still not be released:</p> <ul style="list-style-type: none"> ► Consult a qualified specialist workshop.
	<p>The yellow  warning lamp lights up. If you manually apply or release the electric parking brake, the red  indicator lamp flashes.</p> <p>The electric parking brake is malfunctioning. It is not possible to apply the electric parking brake manually.</p> <ul style="list-style-type: none"> ► Move the transmission selector lever to P. ► Visit a qualified specialist workshop.

Display messages	Possible causes/consequences and ► Solutions
 <p>Parking brake inoperative</p>	<p>The yellow  warning lamp lights up. The red  indicator lamp flashes for about ten seconds after the electric parking brake has been applied or released. It then goes out or remains lit.</p> <p>The electric parking brake is malfunctioning, e.g. because of overvoltage or undervoltage.</p> <ul style="list-style-type: none"> ► Remove the cause for the overvoltage or undervoltage, e.g. by charging the battery or restarting the engine. ► Apply or release the electric parking brake. <p>If it remains impossible to apply or release the electric parking brake:</p> <ul style="list-style-type: none"> ► Switch off the ignition and turn it back on. ► Apply or release the electric parking brake. <p>If the electric parking brake can still not be released:</p> <ul style="list-style-type: none"> ► Consult a qualified specialist workshop. <p>The display message is only shown while the vehicle is in motion. The red  indicator lamp flashes and the yellow  warning lamp is lit.</p> <p>It is not possible to apply the electric parking brake manually.</p> <ul style="list-style-type: none"> ► Move the transmission selector lever to P. ► Visit a qualified specialist workshop.
 <p>Turn on the ignition to release the parking brake</p>	<p>The red  indicator lamp is lit.</p> <p>You attempted to release the electric parking brake while the ignition was switched off.</p> <ul style="list-style-type: none"> ► Key: turn the key to position 1 in the ignition lock. ► KEYLESS-GO: switch on the ignition.
 <p>Check brake fluid level</p>	<p>There is insufficient brake fluid in the brake fluid reservoir. In addition, the  warning lamp in the instrument cluster lights up and a warning tone sounds.</p> <p> WARNING</p> <p>The braking efficiency may be impaired.</p> <p>There is a risk of an accident.</p> <ul style="list-style-type: none"> ► Pull over and stop the vehicle safely as soon as possible, paying attention to road and traffic conditions. Do not continue driving under any circumstances. ► Secure the vehicle against rolling away (▷ page 181). ► Consult a qualified specialist workshop. ► Do not top up the brake fluid. This does not correct the error.

Display messages	Possible causes/consequences and ► Solutions
 <p>Check brake pad wear</p>	<p>The brake pads/linings have reached their wear limit.</p> <p>► Visit a qualified specialist workshop.</p>
<p>PRE-SAFE inoperative See Owner's Manual</p>	<p>Important functions of PRE-SAFE® have failed. All other occupant safety systems, e.g. airbags, remain available.</p> <p>► Visit a qualified specialist workshop immediately.</p>
<p>PRE-SAFE Functions currently limited See Owner's Manual</p>	<p>Vehicles without the Active Driving Assistance package: Adaptive Brake Assist is temporarily inoperative. Possible causes:</p> <ul style="list-style-type: none"> • the function is impaired due to heavy rain or snow. • the sensor in the bumper is dirty. • the radar sensor system is temporarily inoperative, e.g. due to electromagnetic radiation emitted by nearby TV or radio stations or other sources of electromagnetic radiation. • AMG vehicles: ESP® is deactivated. • the system is outside the operating temperature range. • the on-board voltage is too low. <p>Once the causes listed above no longer apply, the display message goes out.</p> <p>Adaptive Brake Assist is operational again.</p> <p>If the display message does not disappear:</p> <ul style="list-style-type: none"> ► Pull over and stop the vehicle safely as soon as possible, paying attention to road and traffic conditions. ► Secure the vehicle against rolling away (▷ page 181). ► Clean the bumpers (▷ page 370). ► Restart the engine. ► AMG vehicles: reactivate ESP® (▷ page 67).

Display messages	Possible causes/consequences and ► Solutions
<p>PRE-SAFE Functions currently limited See Owner's Manual</p>	<p>Vehicles with the Active Driving Assistance package: PRE-SAFE® Brake is temporarily inoperative. Possible causes:</p> <ul style="list-style-type: none"> • the function is impaired due to heavy rain or snow. • the sensors in the radiator trim and in the bumpers are dirty. • the radar sensor system is temporarily inoperative, e.g. due to electromagnetic radiation emitted by nearby TV or radio stations or other sources of electromagnetic radiation. • AMG vehicles: ESP® is deactivated. • the system is outside the operating temperature range. • the on-board voltage is too low. <p>Once the causes listed above no longer apply, the display message goes out. PRE-SAFE® Brake is operational again.</p> <p>If the display message does not disappear:</p> <ul style="list-style-type: none"> ► Pull over and stop the vehicle safely as soon as possible, paying attention to road and traffic conditions. ► Secure the vehicle against rolling away (▷ page 181). ► Clean the sensors in the radiator grille and the bumper (▷ page 370). ► Restart the engine. ► AMG vehicles: reactivate ESP® (▷ page 67).
<p>PRE-SAFE Functions limited See Owner's Manual</p>	<p>Vehicles without the Active Driving Assistance package: Adaptive Brake Assist is faulty. The distance warning function may also have failed.</p> <p>Vehicles with the Active Driving Assistance package: PRE-SAFE® Brake is faulty. BAS PLUS or the distance warning function may also have failed.</p> <ul style="list-style-type: none"> ► Visit a qualified specialist workshop.
	<p>If the symbol appears in the multifunction display, a seat belt tongue has been inserted into a rear seat belt buckle.</p> <p>Further information on the status indicator for the rear seat belts (▷ page 49).</p>



Display messages	Possible causes/consequences and ► Solutions
	<p>If the symbol appears in the multifunction display, a seat belt tongue has not been inserted in a rear seat belt buckle.</p> <p>⚠ WARNING</p> <p>A seat belt which is not worn correctly, or which has not been engaged in the seat belt buckle correctly, cannot provide the intended level of protection.</p> <p>This poses an increased risk of injury.</p> <p>► If necessary, ask the occupants in the rear to fasten their seat belts (▷ page 47).</p> <p>Further information on the status indicator for the rear seat belts (▷ page 49).</p>
 <p>Restraint sys. malfunction Consult workshop</p>	<p>There is a malfunction in the SRS (Supplemental Restraint System).</p> <p>The  warning lamp also lights up in the instrument cluster.</p> <p>⚠ WARNING</p> <p>The airbags or belt tensioners may either be triggered unintentionally or, in the event of an accident, may not be triggered.</p> <p>This poses an increased risk of injury.</p> <p>► Visit a qualified specialist workshop.</p> <p>Further information on occupant safety (▷ page 41).</p>
 <p>Front left malfunction Consult workshop or Front right malfunction Consult workshop</p>	<p>SRS has malfunctioned at the front on the left or right. The  warning lamp also lights up in the instrument cluster.</p> <p>⚠ WARNING</p> <p>The airbags or belt tensioners may either be triggered unintentionally or, in the event of an accident, may not be triggered.</p> <p>This poses an increased risk of injury.</p> <p>► Visit a qualified specialist workshop.</p>
 <p>Rear left malfunction Consult workshop or Rear right malfunction Consult workshop</p>	<p>SRS has malfunctioned at the rear on the left or right. The  warning lamp also lights up in the instrument cluster.</p> <p>⚠ WARNING</p> <p>The airbags or belt tensioners may either be triggered unintentionally or, in the event of an accident, may not be triggered.</p> <p>This poses an increased risk of injury.</p> <p>► Visit a qualified specialist workshop.</p>







Display messages	Possible causes/consequences and ► Solutions
 <p>Rear centre malfunction Consult workshop</p>	<p>SRS has malfunctioned at the rear centre. The  warning lamp also lights up in the instrument cluster.</p> <p>⚠ WARNING</p> <p>The airbags or belt tensioners may either be triggered unintentionally or, in the event of an accident, may not be triggered. This poses an increased risk of injury.</p> <p>► Visit a qualified specialist workshop.</p>
 <p>Left windowbag malfunction Consult workshop or Right windowbag malfunction Consult workshop</p>	<p>There is a malfunction in the left-hand and/or right-hand windowbag. The  warning lamp also lights up in the instrument cluster.</p> <p>⚠ WARNING</p> <p>The left or right windowbag may either be triggered unintentionally or, in the event of an accident, may not be triggered. This poses an increased risk of injury.</p> <p>► Visit a qualified specialist workshop.</p>







Lights





i Display messages about LEDs:



This display message will only appear if all LEDs have failed.





Display messages	Possible causes/consequences and ► Solutions
 <p>Left cornering light or Right cornering light</p>	<p>The left or right-hand cornering light is faulty.</p> <p>► Check whether you are permitted to replace the bulb yourself (> page 129).</p> <p>or</p> <p>► Visit a qualified specialist workshop.</p>
 <p>Left dipped beam or Right dipped beam</p>	<p>The left or right-hand dipped-beam headlamp is faulty.</p> <p>► Check whether you are permitted to replace the bulb yourself (> page 129).</p> <p>or</p> <p>► Visit a qualified specialist workshop.</p>
 <p>Trailer left indicator or Trailer right indicator</p>	<p>The left or right-hand trailer turn signal lamp is faulty.</p> <p>► Check whether you are permitted to replace the bulb yourself.</p> <p>or</p> <p>► Visit a qualified specialist workshop.</p>







Display messages	Possible causes/consequences and ► Solutions
 <p>Rear left indicator or Rear right indicator</p>	<p>The rear left-hand or rear right-hand turn signal is faulty.</p> <ul style="list-style-type: none"> ► Check whether you are permitted to replace the bulb yourself (▷ page 129). <p>or</p> <ul style="list-style-type: none"> ► Visit a qualified specialist workshop.
 <p>Front left indicator or Front right indicator</p>	<p>The front left-hand or front right-hand turn signal is faulty.</p> <ul style="list-style-type: none"> ► Check whether you are permitted to replace the bulb yourself (▷ page 129). <p>or</p> <ul style="list-style-type: none"> ► Visit a qualified specialist workshop.
 <p>Left mirror indicator or Right mirror indicator</p>	<p>The turn signal in the left-hand or right-hand exterior mirror is faulty.</p> <ul style="list-style-type: none"> ► Check whether you are permitted to replace the bulb yourself (▷ page 129). <p>or</p> <ul style="list-style-type: none"> ► Visit a qualified specialist workshop.
 <p>Third brake lamp</p>	<p>The third brake lamp is faulty.</p> <ul style="list-style-type: none"> ► Check whether you are permitted to replace the bulb yourself (▷ page 129). <p>or</p> <ul style="list-style-type: none"> ► Visit a qualified specialist workshop.
 <p>Left brake lamp or Right brake lamp</p>	<p>The left or right-hand brake lamp is faulty.</p> <ul style="list-style-type: none"> ► Check whether you are permitted to replace the bulb yourself (▷ page 129). <p>or</p> <ul style="list-style-type: none"> ► Visit a qualified specialist workshop.
 <p>Left-hand tail lamp/brake lamp or Right-hand tail lamp/brake lamp</p>	<p>The left or right-hand tail lamp/brake lamp is faulty.</p> <ul style="list-style-type: none"> ► Check whether you are permitted to replace the bulb yourself (▷ page 129). <p>or</p> <ul style="list-style-type: none"> ► Visit a qualified specialist workshop.





Display messages	Possible causes/consequences and ► Solutions
 Left main beam or Right main beam	The left or right-hand high beam is faulty. ► Check whether you are permitted to replace the bulb yourself (> page 129). or ► Visit a qualified specialist workshop.
 Number plate lamp	The left or right-hand licence plate lamp is faulty. ► Check whether you are permitted to replace the bulb yourself (> page 129). or ► Visit a qualified specialist workshop.
 Rear fog lamp	The rear fog lamp is faulty. ► Check whether you are permitted to replace the bulb yourself (> page 129). or ► Visit a qualified specialist workshop.
 Front left parking lamp or Front right parking lamp	The front left or front right parking lamp is faulty. ► Check whether you are permitted to replace the bulb yourself (> page 129). or ► Visit a qualified specialist workshop.
 Reversing light	The reversing lamp is faulty. ► Check whether you are permitted to replace the bulb yourself (> page 129). or ► Visit a qualified specialist workshop.
 Left tail lamp or Right tail lamp	The left or right-hand tail lamp is faulty. or The rear left or right side marker lamp is faulty. ► Check whether you are permitted to replace the bulb yourself (> page 129). or ► Visit a qualified specialist workshop.





Display messages	Possible causes/consequences and ► Solutions
 <p>Left daytime driving lamp or Right daytime driving lamp</p>	<p>The left-hand or right-hand daytime driving lamp is faulty.</p> <ul style="list-style-type: none"> ► Check whether you are permitted to replace the bulb yourself (▷ page 129). <p>or</p> <ul style="list-style-type: none"> ► Visit a qualified specialist workshop.
 <p>Intell. Light System inoperative</p>	<p>The Intelligent Light System is faulty. The lights remain available without the Intelligent Light System.</p> <ul style="list-style-type: none"> ► Visit a qualified specialist workshop.
 <p>Malfunction See Owner's Manual</p>	<p>The exterior lighting is faulty.</p> <ul style="list-style-type: none"> ► Visit a qualified specialist workshop. <p>Vehicles with trailer tow hitch: a fuse may have blown.</p> <ul style="list-style-type: none"> ► Check the fuses (▷ page 391). ► If necessary, replace the blown fuse. Observe the warning notes as you do so. <p>If the display message continues to be displayed:</p> <ul style="list-style-type: none"> ► Visit a qualified specialist workshop.
 <p>AUTO lights inoperative</p>	<p>The light sensor is faulty.</p> <ul style="list-style-type: none"> ► Visit a qualified specialist workshop.
 <p>Switch off lights</p>	<p>The lights are still switched on when you leave the vehicle. A warning tone also sounds.</p> <ul style="list-style-type: none"> ► Turn the light switch to AUTO.
<p>Adaptive Main-beam Assist inoperative</p>	<p>Adaptive Highbeam Assist is faulty.</p> <ul style="list-style-type: none"> ► Visit a qualified specialist workshop.
<p>Adaptive Main-beam Assist currently unavailable See Owner's Manual</p>	<p>Adaptive Highbeam Assist is deactivated and temporarily inoperative. Possible causes:</p> <ul style="list-style-type: none"> • the windscreen is dirty in the camera's field of vision. • visibility is impaired due to heavy rain, snow or fog. <ul style="list-style-type: none"> ► Clean the windscreen. <p>If the system detects that the camera is fully operational again, the Adaptive Main-beam Assist available again message is displayed.</p> <p>Adaptive Highbeam Assist is operational again.</p>



Engine	
Display messages	Possible causes/consequences and ► Solutions
 <p>Top up coolant See Owner's Manual</p>	<p>The coolant level is too low.</p> <p>! Avoid making long journeys with too little coolant in the engine cooling system. The engine will otherwise be damaged.</p> <ul style="list-style-type: none"> ► Top up the coolant, observing the warning notes before doing so (► page 363). ► If the coolant needs topping up more often than usual, have the engine coolant system checked at a qualified specialist workshop.
	<p>The fan motor is faulty.</p> <ul style="list-style-type: none"> ► If the coolant temperature is below 120 °C, you can continue driving to the nearest qualified specialist workshop. ► Avoid heavy loads on the engine as you do so, e.g. driving in mountainous terrain and stop-start traffic.
 <p>Coolant Stop vehicle Switch engine off</p>	<p>The coolant is too hot. A warning tone also sounds.</p> <p>⚠ WARNING</p> <p>Never drive with an overheated engine. Driving when your engine is overheated can cause fluids that may have leaked into the engine compartment to catch fire.</p> <p>Steam from an overheated engine can cause serious burns, which can occur just by opening the bonnet.</p> <p>There is a risk of injury.</p> <ul style="list-style-type: none"> ► Stop the vehicle immediately, paying attention to road and traffic conditions, and switch off the engine. ► Secure the vehicle against rolling away (► page 181). ► Leave the vehicle and keep a safe distance from the vehicle until the engine has cooled down. ► Make sure that the air supply to the engine radiator is not blocked, e.g. by frozen slush. ► Do not start the engine again until the display message goes out and the coolant temperature is below 120 °C. The engine may otherwise be damaged. ► Pay attention to the coolant temperature display. ► If the temperature increases again, visit a qualified specialist workshop immediately. <p>Under normal operating conditions and with the specified coolant level, the coolant temperature may rise to 120 °C.</p>

Display messages	Possible causes/consequences and ► Solutions
	<p>The battery is not being charged. A warning tone also sounds.</p> <p>Possible causes:</p> <ul style="list-style-type: none"> • faulty alternator • torn poly-V-belt • a malfunction in the electronics <p>► Stop the vehicle immediately, paying attention to road and traffic conditions, and switch off the engine.</p> <p>► Open the bonnet.</p> <p>► Check whether the poly-V-belt is torn.</p> <p>If the poly-V-belt is torn:</p> <p>! Do not continue driving. The engine could otherwise overheat.</p> <p>► Consult a qualified specialist workshop.</p> <p>If the poly-V-belt is OK:</p> <p>► Visit a qualified specialist workshop.</p>
 <p>Check eng. oil lev. when next refuelling</p>	<p>The engine oil level has dropped to the minimum level. A warning tone also sounds.</p> <p>► Check the oil level when next refuelling, at the latest (> page 362).</p> <p>► If necessary, top up the engine oil (> page 362).</p> <p>► Have the engine checked at a qualified specialist workshop if the engine oil needs topping up more often than usual.</p>
 <p>Top up with 1 litre of engine oil when next refuelling</p>	<p>AMG vehicles: the engine oil level is too low.</p> <p>► Check the oil level when next refuelling, at the latest (> page 362).</p> <p>► If necessary, top up the engine oil (> page 362).</p> <p>► Have the engine checked at a qualified specialist workshop if the engine oil needs topping up more often than usual.</p>
 <p>Reserve fuel level</p>	<p>The fuel level has dropped into the reserve range. Operation of the auxiliary heating is deactivated if the fuel level drops into the reserve range.</p> <p>► Refuel at the nearest filling station.</p>
	<p>There is only a very small amount of fuel in the fuel tank. The auxiliary heating cannot be operated.</p> <p>► Refuel at the nearest filling station without fail.</p>

Display messages	Possible causes/consequences and ► Solutions
 Replace air cleaner	Vehicles with a diesel engine: the engine air filter is dirty and must be replaced. ► Visit a qualified specialist workshop.
 Clean the fuel filter	Vehicles with a diesel engine: there is water in the fuel filter. The water must be drained off. ► Visit a qualified specialist workshop.
 Refill AdBlue See Owner's Manual	The AdBlue® level has fallen below the reserve range. A warning tone also sounds. ► Have AdBlue® refilled as soon as possible at a qualified specialist workshop. or ► Refill AdBlue® yourself as soon as possible (▷ page 178).
 Refill AdBlue No start in .. km	The AdBlue® level is only sufficient for the indicated distance. A warning tone also sounds. ► Have AdBlue® refilled as soon as possible at a qualified specialist workshop. or ► Refill AdBlue® yourself immediately (▷ page 178).
 Refill AdBlue Eng. start not possible	The AdBlue® tank is empty. A warning tone also sounds. You can no longer start the engine. ► Consult a qualified specialist workshop immediately. or ► Refill AdBlue® yourself immediately (▷ page 178).
 Check AdBlue See Owner's Manual	The AdBlue® system is malfunctioning. A warning tone also sounds. ► Visit a qualified specialist workshop.
 Eng. start not possible in ... km	The AdBlue® system is malfunctioning. A warning tone also sounds. ► Visit a qualified specialist workshop immediately.
 Eng. start not possible	The AdBlue® system is malfunctioning. A warning tone also sounds. You can no longer start the engine. ► Consult a qualified specialist workshop immediately.



Driving systems	
Display messages	Possible causes/consequences and ► Solutions
 <p>Attention Assist: Take a break!</p>	<p>Based on certain criteria, ATTENTION ASSIST has detected fatigue or a lack of concentration on the part of the driver. A warning tone also sounds.</p> <ul style="list-style-type: none"> ► If necessary, take a break. <p>During long journeys, take regular breaks in good time so that you get enough rest.</p>
 <p>Attention Assist inoperative</p>	<p>ATTENTION ASSIST is inoperative.</p> <ul style="list-style-type: none"> ► Visit a qualified specialist workshop.
 <p>Please reduce speed</p>	<p>You cannot change the vehicle level. Possible causes:</p> <ul style="list-style-type: none"> • you are driving too fast for the selected vehicle level. • you are towing a trailer. • the trailer-coupling socket is being used, e.g. for a bicycle rack. <ul style="list-style-type: none"> ► Drive more slowly and then select the desired vehicle level again. <ul style="list-style-type: none"> • Vehicles with the ON&OFFROAD package (► page 207) • Vehicles with the AIRMATIC package (► page 213) ► Observe the notes on towing a trailer (► page 257).
 <p>Compressor is cooling</p>	<p>You have selected a higher vehicle level. The compressor first needs to cool down because of frequent level changes.</p> <ul style="list-style-type: none"> ► Drive in a manner appropriate for the current vehicle level. ► Make sure that there is sufficient ground clearance. ► Allow the compressor to cool down. <p>When the compressor has cooled down, the display message disappears. The vehicle then continues rising to the selected level.</p>
 <p>Malfunction</p>	<p>AIRMATIC is faulty.</p> <ul style="list-style-type: none"> ► Drive as appropriate for the current vehicle level, but do not exceed 80 km/h. ► Make sure that there is sufficient ground clearance. ► Have the vehicle checked at a qualified specialist workshop.

Display messages	Possible causes/consequences and ► Solutions
 <p>max. 20 km/h</p>	<p>You are exceeding the speed permissible for the selected off-road level.</p> <p>In addition, the vehicle level display appears between the vehicle icon and the display message, and a warning tone sounds.</p> <p> WARNING</p> <p>The vehicle can tip and roll over. There is a risk of an accident.</p> <ul style="list-style-type: none"> ► Adjust your driving style to the altered handling characteristics. ► Only make slight steering movements and avoid fast steering movements. ► Do not exceed 20 km/h until the vehicle has reached off-road level 2.
<p>Active Curve System malfunctioning</p>	<p>The Active Curve System is faulty. The vehicle's handling characteristics may be affected.</p> <ul style="list-style-type: none"> ► Do not drive at speeds above 80 km/h. ► Have the vehicle checked at a qualified specialist workshop.
<p>Active Curve System malfunctioning see Owner's Manual</p>	<p>The Active Curve System is faulty. The vehicle's handling characteristics are severely impaired. A warning tone also sounds.</p> <p> WARNING</p> <p>There is a risk of an accident.</p> <ul style="list-style-type: none"> ► Drive on carefully. ► Adjust your driving style to the altered handling characteristics. ► Avoid sudden acceleration in tight bends and fast steering movements. ► Do not drive at speeds above 80 km/h. ► Visit a qualified specialist workshop immediately.
 <p>Lowering max. 20 km/h</p>	<p>The vehicle is being lowered from off-road level 3 to off-road level 2. The display message informs you of the maximum speed permissible for off-road level 3.</p> <ul style="list-style-type: none"> ► Do not exceed 20 km/h until the vehicle has reached off-road level 2.
 <p>Different. lock sys. Malfunction</p>	<p>The differential lock is malfunctioning.</p> <ul style="list-style-type: none"> ► Do not drive at speeds above 80 km/h. ► Have the vehicle checked at a qualified specialist workshop.

Display messages	Possible causes/consequences and ► Solutions
 <p>Different. locking sys. cooling down Please wait</p>	<p>The differential lock is too hot and has been disengaged.</p> <ul style="list-style-type: none"> ► Drive on carefully. ► Allow the differential lock to cool down. The differential lock reengages as soon as it has cooled down.
<p>LOW RANGE Stop Apply parking brake</p>	<p>A gearshift process has been cancelled. LOW RANGE is in the neutral position. There is no connection between the engine and the drive wheels.</p> <ul style="list-style-type: none"> ► Pull over and stop the vehicle safely as soon as possible, paying attention to road and traffic conditions. ► Engage the electric parking brake. Do not continue driving under any circumstances. ► Repeat the gearshift process.
<p>LOW RANGE Malfunction To park, apply parking brake</p>	<p>LOW RANGE is malfunctioning.</p> <ul style="list-style-type: none"> ► Do not drive at speeds above 80 km/h. ► When parking, secure the vehicle against rolling away (▷ page 181). ► Have the vehicle checked at a qualified specialist workshop.
<p>LOW RANGE max. 40 km/h</p>	<p>You have exceeded the maximum speed for the gearshift process.</p> <ul style="list-style-type: none"> ► Drive more slowly. The gear change is made.
<p>LOW RANGE max. 70 km/h</p>	<p>You have exceeded the maximum speed for the gearshift process.</p> <ul style="list-style-type: none"> ► Drive more slowly. The gear change is made.
<p>LOW RANGE Shift to position N briefly</p>	<p>You have reduced the vehicle speed, but the automatic transmission is not in position N.</p> <ul style="list-style-type: none"> ► Briefly shift the automatic transmission to position N.
<p>LOW RANGE Shifting cancelled Please reactivate</p>	<p>The gearshift process has been cancelled.</p> <ul style="list-style-type: none"> ► Repeat the gearshift process.
 <p>inoperative</p>	<p>DSR (Downhill Speed Regulation) is deactivated due to a fault.</p> <ul style="list-style-type: none"> ► Have DSR checked at a qualified specialist workshop.

Display messages	Possible causes/consequences and ► Solutions
Speed Limit Assist currently unavailable See Owner's Manual	<p>Speed Limit Assist is deactivated and temporarily inoperative. Possible causes:</p> <ul style="list-style-type: none"> • the windscreen is dirty in the camera's field of vision. • visibility is impaired due to heavy rain, snow or fog. <p>► Clean the windscreen.</p> <p>If the system detects that the camera is fully operational, the display message disappears.</p> <p>Speed Limit Assist is operational again.</p>
Speed Limit Assist: Unavailable in this country	<p>Speed Limit Assist is only available in certain countries.</p> <p>► Drive on.</p> <p>Speed Limit Assist is available again as soon as you drive in a country in which its use is approved.</p>
Speed Limit Assist inoperative	<p>Speed Limit Assist is faulty.</p> <p>► Visit a qualified specialist workshop.</p>
HOLD Off	<p>The HOLD function is deactivated. The vehicle is skidding. A warning tone also sounds.</p> <p>► Reactivate the HOLD function later (▷ page 211).</p>
Radar sensor deactivated See Owner's Manual	<p>The radar sensor system is deactivated.</p> <p>► Check whether or not the radar sensor system may be activated (▷ page 433).</p> <p>► Switch on the radar sensor system (▷ page 283).</p>
Radar sensor deactivated autom. See Owner's Manual	<p>Vehicles with a navigation system: the vehicle is close to a radio telescope facility and is therefore prohibited from transmitting any radar signals. The radar sensor system has switched off automatically (▷ page 433).</p> <p>If DISTRONIC PLUS was enabled, it is no longer available. A warning tone also sounds.</p> <p>If Blind Spot Assist or Active Blind Spot Assist was enabled, it is no longer available. The yellow  indicator lamps also light up in the exterior mirrors.</p> <p>BAS PLUS (Brake Assist PLUS) and PRE-SAFE® Brake are then also no longer available.</p> <p>► Drive on.</p> <p>Once you have moved far enough away from the radio telescope, the above functions are available again.</p>

Display messages	Possible causes/consequences and ► Solutions
	<p>Vehicles with Becker® MAP PILOT: if the Becker® MAP PILOT is not connected, the radar sensor system is deactivated automatically.</p> <p>BAS PLUS, DISTRONIC PLUS, Blind Spot Assist or Active Blind Spot Assist and PRE-SAFE® Brake are not available.</p> <p>► Connect the Becker® MAP PILOT; see the separate operating instructions.</p>
<p>Lane Keeping Assist currently unavailable See Owner's Manual</p> <p>Active Lane Keeping Assist currently unavailable See Owner's Manual</p>	<p>Lane Keeping Assist or Active Lane Keeping Assist is deactivated and temporarily inoperative. Possible causes:</p> <ul style="list-style-type: none"> • the windscreen is dirty in the camera's field of vision. • visibility is impaired due to heavy rain, snow or fog. • there are no lane markings for a longer period. • the lane markings are worn, dark or covered, e.g. by dirt or snow. <p>When the causes listed above no longer apply, the display message goes out.</p> <p>Lane Keeping Assist or Active Lane Keeping Assist is operational again.</p> <p>If the display message does not disappear:</p> <ul style="list-style-type: none"> ► Pull over and stop the vehicle safely as soon as possible, paying attention to road and traffic conditions. ► Secure the vehicle against rolling away (► page 181). ► Clean the windscreen.
<p>Lane Keeping Assist inoperative</p> <p>Active Lane Keeping Assist inoperative</p>	<p>Lane Keeping Assist or Active Lane Keeping Assist is faulty.</p> <ul style="list-style-type: none"> ► Visit a qualified specialist workshop.
<p>Blind Spot Assist currently unavailable See Owner's Manual</p> <p>Active Blind Spot Assist currently unavailable See Owner's Manual</p>	<p>Blind Spot Assist or Active Blind Spot Assist is temporarily inoperative.</p> <p>You have established the electrical connection between the trailer and your vehicle.</p> <ul style="list-style-type: none"> ► Press <input type="button" value="OK"/> on the steering wheel to confirm the display message. <p>Blind Spot Assist or Active Blind Spot Assist is deactivated while towing a trailer.</p>

Display messages	Possible causes/consequences and ► Solutions
	<p>Blind Spot Assist or Active Blind Spot Assist is temporarily inoperative. Possible causes:</p> <ul style="list-style-type: none"> • the sensors are dirty. • the function is impaired due to heavy rain or snow. • the radar sensor system is outside the operating temperature range. • the radar sensor system is temporarily inoperative, e.g. due to electromagnetic radiation emitted by nearby TV or radio stations or other sources of electromagnetic radiation. <p>The yellow  indicator lamps also light up in the exterior mirrors.</p> <p>When the causes listed above no longer apply, the display message goes out.</p> <p>Blind Spot Assist or Active Blind Spot Assist is operational again.</p> <p>If the display message does not disappear:</p> <ul style="list-style-type: none"> ► Pull over and stop the vehicle safely as soon as possible, paying attention to road and traffic conditions. ► Secure the vehicle against rolling away (▷ page 181). ► Clean the sensors (▷ page 370). ► Restart the engine.
<p>Blind Spot Assist inoperative Active Blind Spot Assist inoperative</p>	<p>Blind Spot Assist or Active Blind Spot Assist is faulty.</p> <p>The yellow  indicator lamps also light up in the exterior mirrors.</p> <ul style="list-style-type: none"> ► Visit a qualified specialist workshop.
<p>Park Assist cancelled</p>	<p>The driver's door is open and the driver's seat belt has not been fastened.</p> <ul style="list-style-type: none"> ► Repeat the parking process with the seat belt fastened and the driver's door closed. <p>You have inadvertently touched the multifunction steering wheel while steering intervention was active.</p> <ul style="list-style-type: none"> ► While steering intervention is active, make sure not to touch the multifunction steering wheel. <p>The vehicle has started to skid and ESP® has intervened.</p> <ul style="list-style-type: none"> ► Use Active Parking Assist again later (▷ page 219).





Display messages	Possible causes/consequences and ► Solutions
Park Assist inoperative	<p>You have just carried out a large number of turning or parking manoeuvres.</p> <p>Active Parking Assist will become available again after approximately ten minutes (▷ page 219).</p> <ul style="list-style-type: none"> ► Pull over and stop the vehicle safely as soon as possible, paying attention to road and traffic conditions. ► Switch off and restart the engine. <p>If the display message continues to be displayed:</p> <ul style="list-style-type: none"> ► Visit a qualified specialist workshop. <p>PARKTRONIC is faulty.</p> <ul style="list-style-type: none"> ► Visit a qualified specialist workshop.
Park Assist switched off	<p>The vehicle is parked. A warning tone also sounds.</p> <p>The display message disappears automatically.</p>
DISTRONIC PLUS off	<p>DISTRONIC PLUS has been deactivated (▷ page 198).</p> <p>If it was deactivated automatically, a warning tone also sounds.</p>
DISTRONIC PLUS available again	<p>DISTRONIC PLUS is operational again after having been temporarily unavailable. You can now reactivate DISTRONIC PLUS (▷ page 198).</p>
DISTRONIC PLUS currently unavailable See Owner's Manual	<p>DISTRONIC PLUS is temporarily inoperative. Possible causes:</p> <ul style="list-style-type: none"> • the function is impaired due to heavy rain or snow. • the sensors in the radiator trim and in the bumpers are dirty. • the radar sensor system is temporarily inoperative, e.g. due to electromagnetic radiation emitted by nearby TV or radio stations or other sources of electromagnetic radiation. • the system is outside the operating temperature range. • the on-board voltage is too low. <p>A warning tone also sounds.</p> <p>When the causes listed above no longer apply, the display message goes out.</p> <p>DISTRONIC is operational again.</p> <p>If the display message does not disappear:</p> <ul style="list-style-type: none"> ► Pull over and stop the vehicle safely as soon as possible, paying attention to road and traffic conditions. ► Secure the vehicle against rolling away (▷ page 181). ► Clean the sensors in the radiator trim and in the bumpers (▷ page 370). ► Restart the engine.

Display messages	Possible causes/consequences and ► Solutions
DISTRONIC PLUS inoperative	DISTRONIC PLUS is faulty. BAS PLUS and PRE-SAFE® Brake may also have failed. A warning tone also sounds. ► Visit a qualified specialist workshop.
DISTRONIC PLUS inactive	You have depressed the accelerator pedal. DISTRONIC PLUS is no longer controlling the speed of the vehicle. ► Remove your foot from the accelerator pedal.
DISTRONIC PLUS --- km/h	An activation condition for DISTRONIC PLUS is not fulfilled. ► Check the activation conditions for DISTRONIC PLUS (► page 198).
DISTRONIC PLUS and SPEEDTRONIC inoperative	DISTRONIC PLUS and SPEEDTRONIC are faulty. A warning tone also sounds. ► Visit a qualified specialist workshop.
Cruise control and SPEEDTRONIC inoperative	SPEEDTRONIC and cruise control are malfunctioning. ► Visit a qualified specialist workshop.
Limit - - - km/h	While depressing the accelerator pedal beyond the pressure point (kickdown), SPEEDTRONIC cannot be activated.
Cruise control - - - km/h	A condition for activating cruise control has not been met. You have tried to store a speed below 30 km/h, for example. ► If conditions permit, drive faster than 30 km/h and store the speed. ► Check the activation conditions for cruise control (► page 193).
120 km/h Maximum speed exceeded	Only for certain countries: the maximum speed has been exceeded. In addition, the multifunction display shows 120 km/h! . ► Drive more slowly.







Tyres	
Display messages	Possible causes/consequences and ► Solutions
Tyre pressure Check tyres	<p>The tyre pressure loss warning system has detected a significant loss in pressure.</p> <p>A warning tone also sounds.</p> <p> WARNING</p> <p>With tyre pressures which are too low, there is a risk of the following hazards:</p> <ul style="list-style-type: none"> • they may burst, especially as the load and vehicle speed increase. • they may wear excessively and/or unevenly, which may greatly impair tyre traction. • the driving characteristics, as well as steering and braking, may be greatly impaired. <p>There is a risk of an accident.</p> <ul style="list-style-type: none"> ► Stop the vehicle without making any sudden steering or braking manoeuvres. Pay attention to the traffic conditions as you do so. ► Secure the vehicle against rolling away (► page 181). ► If there is a flat tyre, inspect the tyres (► page 378). ► Check the tyre pressures and, if necessary, correct the tyre pressure. ► Restart the tyre pressure loss warning system when the tyre pressure is correct (► page 401).
Check tyre pressures then restart Run Flat Indicator	<p>The tyre pressure loss warning system generated a display message and has not been restarted since.</p> <ul style="list-style-type: none"> ► Set the correct tyre pressure in all four tyres. ► Restart the tyre pressure loss warning system (► page 401).
Run Flat Indicator inoperative	<p>The tyre pressure loss warning system is faulty.</p> <ul style="list-style-type: none"> ► Visit a qualified specialist workshop.
Tyre pressure will be displayed after driving a few minutes	<p>The tyre pressure monitor is measuring the tyre pressure.</p> <ul style="list-style-type: none"> ► Drive on. <p>The tyre pressures appear in the multifunction display after you have been driving for a few minutes.</p>
Tyre press. monitor inoperative	<p>The tyre pressure monitor is faulty.</p> <ul style="list-style-type: none"> ► Visit a qualified specialist workshop.





Display messages	Possible causes/consequences and ► Solutions
Tyre press. monitor inoperative No wheel sensors	<p>The wheels fitted do not have a suitable tyre pressure sensor. The tyre pressure monitor is deactivated.</p> <p>► Fit wheels with suitable tyre pressure sensors. The tyre pressure monitor is activated automatically after driving for a few minutes.</p>
Check tyre(s)	<p>The tyre pressure in one or more tyres has dropped significantly. The wheel position is displayed in the multifunction display. A warning tone also sounds.</p> <p> WARNING</p> <p>With tyre pressures which are too low, there is a risk of the following hazards:</p> <ul style="list-style-type: none"> • they may burst, especially as the load and vehicle speed increase. • they may wear excessively and/or unevenly, which may greatly impair tyre traction. • the driving characteristics, as well as steering and braking, may be greatly impaired. <p>There is a risk of an accident.</p> <p>► Stop the vehicle without making any sudden steering or braking manoeuvres. Pay attention to the traffic conditions as you do so.</p> <p>► Secure the vehicle against rolling away (▷ page 181).</p> <p>► If there is a flat tyre, inspect the tyres (▷ page 378).</p> <p>► Check the tyre pressure (▷ page 402).</p> <p>► If necessary, correct the tyre pressure.</p>



Display messages	Possible causes/consequences and ► Solutions
Warning tyre defect	<p>The tyre pressure in one or more tyres has dropped suddenly. The wheel position is displayed in the multifunction display.</p> <p> WARNING</p> <p>If you drive with a flat tyre, there is a risk of the following hazards:</p> <ul style="list-style-type: none"> • A flat tyre affects the ability to steer or brake the vehicle. • You could lose control of the vehicle. • Continued driving with a flat tyre will cause excessive heat build-up and possibly a fire. <p>There is a risk of an accident.</p> <ul style="list-style-type: none"> ► Stop the vehicle without making any sudden steering or braking manoeuvres. Pay attention to the traffic conditions as you do so. ► Secure the vehicle against rolling away (▷ page 181). ► If there is a flat tyre, inspect the tyres (▷ page 378).
Rectify tyre pressure	<p>The tyre pressure is too low in at least one of the tyres, or the tyre pressure difference between the wheels is too great.</p> <ul style="list-style-type: none"> ► Check the tyre pressures at the next opportunity (▷ page 402). ► If necessary, correct the tyre pressure. ► Restart the tyre pressure monitor (▷ page 403).
Wheel sensor(s) missing	<p>There is no signal from the tyre pressure sensor of one or several wheels. The pressure of the affected tyre is not displayed in the multifunction display.</p> <ul style="list-style-type: none"> ► Have the faulty tyre pressure sensor replaced at a qualified specialist workshop.
Tyre press. monitor currently unavailable	<p>Due to a source of radio interference, no signals can be received from the wheel sensors. The tyre pressure monitor is temporarily malfunctioning.</p> <ul style="list-style-type: none"> ► Drive on. The tyre pressure monitor restarts automatically as soon as the problem has been solved.

Display messages	Possible causes/consequences and ► Solutions
 <p>Tyre pressure Caution Tyre malfunction</p>	<p>The tyre pressure in one or more tyres has dropped suddenly. A warning tone also sounds.</p> <p> WARNING</p> <p>If you drive with a flat tyre, there is a risk of the following hazards:</p> <ul style="list-style-type: none"> • A flat tyre affects the ability to steer or brake the vehicle. • You could lose control of the vehicle. • Continued driving with a flat tyre will cause excessive heat build-up and possibly a fire. There is a risk of an accident. <p>► Stop the vehicle without making any sudden steering or braking manoeuvres. Pay attention to the traffic conditions as you do so.</p> <p>► Secure the vehicle against rolling away (▷ page 181).</p> <p>► If there is a flat tyre, inspect the tyres (▷ page 378).</p>
 <p>Tyre pressure Check tyre(s)</p>	<p>The tyre pressure in one or more tyres has dropped significantly.</p> <p> WARNING</p> <p>With tyre pressures which are too low, there is a risk of the following hazards:</p> <ul style="list-style-type: none"> • they may burst, especially as the load and vehicle speed increase. • they may wear excessively and/or unevenly, which may greatly impair tyre traction. • the driving characteristics, as well as steering and braking, may be greatly impaired. There is a risk of an accident. <p>► Stop the vehicle without making any sudden steering or braking manoeuvres. Pay attention to the traffic conditions as you do so.</p> <p>► Secure the vehicle against rolling away (▷ page 181).</p> <p>► If there is a flat tyre, inspect the tyres (▷ page 378).</p> <p>► Check the tyre pressure (▷ page 402).</p> <p>► If necessary, correct the tyre pressure.</p>
 <p>Please correct tyre pressure</p>	<p>The tyre pressure is too low in at least one of the tyres, or the tyre pressure difference between the wheels is too great.</p> <p>► Check the tyre pressures at the next opportunity (▷ page 402).</p> <p>► If necessary, correct the tyre pressure.</p>



Vehicle	
Display messages	Possible causes/consequences and ► Solutions
To start engine, shift to either P or N	You have attempted to start the engine with the transmission in position R or D . ► Shift the transmission to position P or N .
Auxiliary battery malfunction	The auxiliary battery for the automatic transmission is no longer being charged. ► Visit a qualified specialist workshop at the next opportunity. ► Until then, set the automatic transmission to position P before you switch off the engine. ► Before leaving the vehicle, apply the electric parking brake. ► Secure the vehicle against rolling away (▷ page 181).
Apply brake to deselect Park (P) position	You have attempted to move the transmission selector lever to position D , R or N without depressing the brake pedal. ► Depress the brake pedal.
Risk of vehicle rolling Transmission not in P	The driver's door is open and the transmission is in position R , N or D . A warning tone also sounds. ► Shift the transmission to position P . ► Secure the vehicle against rolling away (▷ page 181).
Without changing gear, consult workshop	You cannot change the transmission position due to a malfunction. A warning tone also sounds. If transmission position D is selected: ► Drive to a qualified specialist workshop without shifting the transmission from position D . If transmission position R , N or P is selected: ► Consult a qualified specialist workshop.
Only select Park (P) when vehicle is stationary	The vehicle is moving. ► Pull over and stop the vehicle safely as soon as possible, paying attention to road and traffic conditions. ► Shift the transmission to position P .





Display messages	Possible causes/consequences and ► Solutions
	<p>The tailgate is open.</p> <p> WARNING</p> <p>When the engine is running, exhaust gases can enter the vehicle interior if the tailgate is open.</p> <p>There is a risk of poisoning.</p> <p>► Close the tailgate.</p>
	<p>The bonnet is open.</p> <p>A warning tone also sounds.</p> <p> WARNING</p> <p>The open bonnet may then block your view when the vehicle is in motion.</p> <p>There is a risk of an accident.</p> <p>► Pull over and stop the vehicle safely as soon as possible, paying attention to road and traffic conditions.</p> <p>► Secure the vehicle against rolling away (▷ page 181).</p> <p>► Close the bonnet.</p>
<p>Active bonnet malfunction See Owner's Manual</p>	<p>The active bonnet (pedestrian protection) is not active due to a malfunction or because it has already been triggered.</p> <p>► Visit a qualified specialist workshop.</p>
	<p>At least one door is open.</p> <p>A warning tone also sounds.</p> <p>► Close all doors.</p>
 <p>2nd seat row, left Not locked or 2nd seat row, right Not locked</p>	<p>The second row of seats is not engaged on the left-hand and/or right-hand side in the rear.</p> <p>► Fold back the second row of seats until it engages.</p>
 <p>3rd seat row, left Not locked or 3rd seat row, right Not locked</p>	<p>The third row of seats is not engaged on the left-hand or right-hand side.</p> <p>► Fold back the third row of seats until it engages.</p>

Display messages	Possible causes/consequences and ► Solutions
 <p>Check trailer hitch lock</p>	<p>The trailer tow hitch is not correctly engaged. A warning tone also sounds.</p> <ul style="list-style-type: none"> ► Stop the vehicle immediately, paying attention to road and traffic conditions, and switch off the engine. ► Secure the vehicle against rolling away (▷ page 181). ► Engage the trailer coupling's ball coupling in the end position (▷ page 259).
 <p>Power steering malfunction See Owner's Manual</p>	<p>The power steering assistance is faulty. A warning tone also sounds.</p> <p>▲ WARNING</p> <p>You will need to use more force to steer. There is a risk of an accident.</p> <ul style="list-style-type: none"> ► Check whether you are able to apply the extra force required. ► If you are able to steer safely: carefully drive on to a qualified specialist workshop. ► If you are unable to steer safely: do not drive on. Contact the nearest qualified specialist workshop.
 <p>inoperative Battery low</p>	<p>You have attempted to switch on the auxiliary heating or to activate a departure time using the on-board computer after operating the auxiliary heating twice.</p> <ul style="list-style-type: none"> ► Let the engine run for 10 seconds. The auxiliary heating is operational again. <p>The on-board voltage is too low. The auxiliary heating has switched itself off or cannot be switched on (▷ page 148).</p> <ul style="list-style-type: none"> ► Drive for a longer distance. The battery is being charged. The auxiliary heating is operational again as soon as the on-board electrical system voltage is sufficient.
 <p>inoperative Refuel vehicle</p>	<p>There is too little fuel in the fuel tank. The auxiliary heating cannot be switched on (▷ page 148).</p> <ul style="list-style-type: none"> ► Refuel at the nearest filling station.

Display messages	Possible causes/consequences and ► Solutions
 <p>inoperative See Owner's Man.</p>	<p>The auxiliary heating has a temporary malfunction or is faulty.</p> <ul style="list-style-type: none"> ► When the vehicle is on a level surface and the engine has cooled down, make up to four attempts to switch on the auxiliary heating, waiting several minutes between each attempt (▷ page 148). ► If the auxiliary heating does not switch on, consult a qualified specialist workshop.
<p>Telephone No service</p>	<p>Your vehicle is outside the network provider's transmitter/receiver range.</p> <ul style="list-style-type: none"> ► Wait until the mobile phone operational readiness symbol appears in the multifunction display.
 <p>Top up washer fluid</p>	<p>The washer fluid level in the washer fluid reservoir has dropped below the minimum.</p> <ul style="list-style-type: none"> ► Top up the washer fluid (▷ page 364).
<p>Wiper malfunctioning</p>	<p>The windscreen wipers are malfunctioning.</p> <ul style="list-style-type: none"> ► Visit a qualified specialist workshop.
<p>Hazard warning lamps malfunctioning</p>	<p>The hazard warning lamps are faulty.</p> <ul style="list-style-type: none"> ► Visit a qualified specialist workshop.





















Key

Display messages	Possible causes/consequences and ► Solutions
 <p>Key does not belong to vehicle</p>	<p>You have put the wrong key in the ignition lock.</p> <ul style="list-style-type: none"> ► Use the correct key.
 <p>Replace key</p>	<p>The key needs to be replaced.</p> <ul style="list-style-type: none"> ► Visit a qualified specialist workshop.
 <p>Change key batteries</p>	<p>The batteries of the KEYLESS-GO key are discharged.</p> <ul style="list-style-type: none"> ► Change the batteries (▷ page 79).

Display messages	Possible causes/consequences and ► Solutions
 <p>Key not detected (red display message)</p>	<p>The KEYLESS-GO key is not in the vehicle. A warning tone also sounds. If the engine is switched off, you can no longer lock the vehicle centrally or start the engine.</p> <ul style="list-style-type: none"> ► Pull over and stop the vehicle safely as soon as possible, paying attention to road and traffic conditions. ► Secure the vehicle against rolling away (► page 181). ► Locate the KEYLESS-GO key. <p>The KEYLESS-GO key is not detected while the engine is running because there is interference from a strong source of radio waves. A warning tone also sounds.</p> <ul style="list-style-type: none"> ► Pull over and stop the vehicle safely as soon as possible, paying attention to road and traffic conditions. ► Secure the vehicle against rolling away (► page 181). ► Operate the vehicle with the key in the ignition lock if necessary.
 <p>Key not detected (white display message)</p>	<p>The KEYLESS-GO key cannot be detected at present.</p> <ul style="list-style-type: none"> ► Change the location of the key with the KEYLESS-GO functions in the vehicle. <p>If the KEYLESS-GO key is still not detected:</p> <ul style="list-style-type: none"> ► Operate the vehicle with the key in the ignition lock if necessary.
 <p>Key still in vehicle</p>	<p>The KEYLESS-GO key has been detected inside the vehicle during locking.</p> <ul style="list-style-type: none"> ► Remove the KEYLESS-GO key from the vehicle.
 <p>Remove starting button, then insert key</p>	<p>KEYLESS-GO is temporarily malfunctioning or is defective. A warning tone also sounds.</p> <ul style="list-style-type: none"> ► Insert the key into the ignition lock and turn it to the desired position. ► Visit a qualified specialist workshop.
 <p>Close doors to lock vehicle</p>	<p>At least one door is open. A warning tone also sounds.</p> <ul style="list-style-type: none"> ► Close all doors and lock the vehicle again.





Warning and indicator lamps in the instrument cluster

Warning and indicator lamps overview







	Dipped-beam headlamps (▷ page 120)
	Side lamps (▷ page 119)
	Main-beam headlamps (▷ page 122)
 	Turn signals (▷ page 121)
	Rear foglamp (▷ page 120)
	Seat belts (▷ page 325)
	Brakes (▷ page 326)
	ABS (▷ page 327)
	ESP® (▷ page 329)
	ESP® OFF (▷ page 329)
	Electric parking brake (red) (▷ page 332)
	Electric parking brake (yellow) (▷ page 332)
	SRS (▷ page 332)
	Engine diagnostics (▷ page 333)
	Reserve fuel (▷ page 333)
	Coolant (▷ page 333)
	Distance warning function (▷ page 335)
	Diesel engine: preglow (▷ page 161)
	Tyre pressure monitor (▷ page 336)



Safety



Seat belts







Problem	Possible causes/consequences and ► Solutions
 <p>Only for certain countries: the red seat belt warning lamp lights up for six seconds after the engine starts.</p>	<p>The seat belt warning lamp reminds the driver and front passenger to fasten their seat belts.</p> <ul style="list-style-type: none"> ► Fasten your seat belt (▷ page 47).
 <p>Only for certain countries: the red seat belt warning lamp lights up after the engine starts. In addition, a warning tone sounds for up to six seconds.</p>	<p>The driver's seat belt is not fastened.</p> <ul style="list-style-type: none"> ► Fasten your seat belt (▷ page 47). The warning tone ceases.
 <p>The red seat belt warning lamp lights up after the engine starts, as soon as the driver's or the front-passenger door is closed.</p>	<p>The driver or front passenger has not fastened their seat belt.</p> <ul style="list-style-type: none"> ► Fasten your seat belt (▷ page 47). The warning lamp goes out. <p>There are objects on the front-passenger seat.</p> <ul style="list-style-type: none"> ► Remove the objects from the front-passenger seat and stow them in a secure place. The warning lamp goes out.
 <p>The red seat belt warning lamp flashes and an intermittent audible warning sounds.</p>	<p>The driver or front passenger has not fastened their seat belt. At the same time, you are driving faster than 25 km/h or have briefly driven faster than 25 km/h.</p> <ul style="list-style-type: none"> ► Fasten your seat belt (▷ page 47). The warning lamp goes out and the intermittent warning tone ceases. <p>There are objects on the front-passenger seat. At the same time, you are driving faster than 25 km/h or have briefly driven faster than 25 km/h.</p> <ul style="list-style-type: none"> ► Remove the objects from the front-passenger seat and stow them in a secure place. The warning lamp goes out and the intermittent warning tone ceases.





Safety systems



Problem	Possible causes/consequences and ► Solutions
 <p>The yellow brake system warning lamp lights up while the engine is running.</p>	<p> WARNING</p> <p>The brake system is malfunctioning and the braking characteristics may be affected.</p> <p>There is a risk of an accident.</p> <ul style="list-style-type: none"> ► If the multifunction display shows a display message, please observe this. ► Drive on carefully. ► Visit a qualified specialist workshop.
 <p>The red brake system warning lamp comes on while the engine is running. A warning tone also sounds.</p>	<p> WARNING</p> <p>The brake boosting effect is malfunctioning and the braking characteristics may be affected.</p> <p>There is a risk of an accident.</p> <ul style="list-style-type: none"> ► Pull over and stop the vehicle safely as soon as possible, paying attention to road and traffic conditions. Do not continue driving under any circumstances. ► Secure the vehicle against rolling away (▷ page 181). ► Consult a qualified specialist workshop. ► Observe the additional display messages in the multifunction display.
 <p>The red brake system warning lamp comes on while the engine is running. A warning tone also sounds.</p>	<p>There is insufficient brake fluid in the fluid reservoir.</p> <p> WARNING</p> <p>The braking efficiency may be impaired.</p> <p>There is a risk of an accident.</p> <ul style="list-style-type: none"> ► Pull over and stop the vehicle safely as soon as possible, paying attention to road and traffic conditions. Do not continue driving under any circumstances. ► Secure the vehicle against rolling away (▷ page 181). ► Do not top up the brake fluid. Topping up will not rectify the fault. ► Consult a qualified specialist workshop. ► Observe the additional display messages in the multifunction display.



Problem	Possible causes/consequences and ► Solutions
 <p>The yellow ABS warning lamp is lit while the engine is running.</p>	<p>ABS (Anti-lock Brake System) has been deactivated due to a fault. For this reason, BAS (Brake Assist), BAS PLUS, ESP® (Electronic Stability Program), PRE-SAFE®, PRE-SAFE® Brake, COLLISION PREVENTION ASSIST, the HOLD function, hill start assist, cross-wind driving assistance, adaptive brake lights and ESP® trailer stabilisation, for example, are also deactivated.</p> <p>ATTENTION ASSIST is deactivated.</p> <p> WARNING</p> <p>The brake system continues to function normally, but without the functions listed above. The wheels could therefore lock if you brake hard, for example.</p> <p>The steerability and braking characteristics may be severely affected. The braking distance in an emergency braking situation can increase.</p> <p>If ESP® is not operational, ESP® is unable to stabilise the vehicle. The danger of skidding and having an accident increases.</p> <ul style="list-style-type: none"> ► Observe the additional display messages in the multifunction display. ► Drive on carefully. ► Visit a qualified specialist workshop. <p>If the ABS control unit is faulty, there is also a possibility that other systems, such as the navigation system or the automatic transmission, will not be available.</p>



Problem	Possible causes/consequences and ► Solutions
 <p>The yellow ABS warning lamp is lit while the engine is running.</p>	<p>ABS is temporarily unavailable. Therefore, BAS, BAS PLUS, ESP®, EBD (electronic brake force distribution), PRE-SAFE®, PRE-SAFE® Brake, COLLISION PREVENTION ASSIST, the HOLD function, hill start assist, crosswind driving assistance, the adaptive brake lights and ESP® trailer stabilisation, for example, are also deactivated.</p> <p>ATTENTION ASSIST is deactivated.</p> <p>Possible causes:</p> <ul style="list-style-type: none"> • self-diagnosis is not yet complete. • the on-board voltage may be insufficient. <p> WARNING</p> <p>The brake system continues to function normally, but without the functions listed above. The front and rear wheels could therefore lock if you brake hard, for example.</p> <p>The steerability and braking characteristics may be severely affected. The braking distance in an emergency braking situation can increase.</p> <p>If ESP® is not operational, ESP® is unable to stabilise the vehicle. There is a risk of an accident.</p> <p>► Carefully drive on a suitable stretch of road, making slight steering movements at a speed above 20 km/h. The functions mentioned above are available again when the warning lamp goes out.</p> <p>If the warning lamp is still on:</p> <ul style="list-style-type: none"> ► Observe the additional display messages in the multifunction display. ► Drive on carefully. ► Visit a qualified specialist workshop.



Problem	Possible causes/consequences and ► Solutions
 <p>The yellow ABS warning lamp is lit while the engine is running. A warning tone also sounds.</p>	<p>EBD is faulty. Therefore, ABS, BAS, BAS PLUS, ESP[®], PRE-SAFE[®], PRE-SAFE[®] Brake, COLLISION PREVENTION ASSIST, the HOLD function, hill start assist, crosswind driving assistance, the adaptive brake lights and ESP[®] trailer stabilisation, for example, are also not available.</p> <p>ATTENTION ASSIST is deactivated.</p> <p> WARNING</p> <p>The brake system continues to function normally, but without the functions listed above. The front and rear wheels could therefore lock if you brake hard, for example.</p> <p>The steerability and braking characteristics may be severely affected. The braking distance in an emergency braking situation can increase.</p> <p>If ESP[®] is not operational, ESP[®] is unable to stabilise the vehicle. The danger of skidding and having an accident increases.</p> <ul style="list-style-type: none"> ► Observe the additional display messages in the multifunction display. ► Drive on carefully. ► Visit a qualified specialist workshop.
    <p>The red brake warning lamp, the yellow ESP[®] and ESP[®] OFF warning lamps and the yellow ABS warning lamp are lit while the engine is running.</p>	<p>ABS and ESP[®] are malfunctioning. For this reason, BAS PLUS, PRE-SAFE[®], PRE-SAFE[®] Brake, COLLISION PREVENTION ASSIST, the HOLD function, hill start assist, crosswind driving assistance, the adaptive brake lights and ESP[®] trailer stabilisation, for example, are also not available.</p> <p>ATTENTION ASSIST is deactivated.</p> <p> WARNING</p> <p>The brake system continues to function normally, but without the functions listed above. The front and rear wheels could therefore lock if you brake hard, for example.</p> <p>The steerability and braking characteristics may be severely affected. The braking distance in an emergency braking situation can increase.</p> <p>If ESP[®] is not operational, ESP[®] is unable to stabilise the vehicle. The danger of skidding and having an accident increases.</p> <ul style="list-style-type: none"> ► Observe the additional display messages in the multifunction display. ► Drive on carefully. ► Visit a qualified specialist workshop.

Problem	Possible causes/consequences and ► Solutions
 <p>The yellow ESP® warning lamp flashes while the vehicle is in motion.</p>	<p>ESP® or traction control has intervened because there is a risk of skidding or at least one wheel has started to spin. Cruise control or DISTRONIC PLUS is deactivated.</p> <ul style="list-style-type: none"> ► Only depress the accelerator pedal as far as necessary when pulling away. ► Accelerate more gently while the vehicle is in motion. ► Adapt your driving style to suit the road and weather conditions. ► Do not deactivate ESP®. <p>Exceptions: (► page 66)</p>
 <p>The yellow ESP® OFF warning lamp is lit while the engine is running.</p>	<p>ESP® is deactivated.</p> <p> WARNING</p> <p>If ESP® is switched off, ESP® is unable to stabilise the vehicle. The danger of skidding and having an accident increases.</p> <ul style="list-style-type: none"> ► Reactivate ESP®. <p>Exceptions: (► page 66)</p> <ul style="list-style-type: none"> ► Adapt your driving style to suit the road and weather conditions. <p>If ESP® cannot be activated:</p> <ul style="list-style-type: none"> ► Have ESP® checked at a qualified specialist workshop.
 <p>The yellow ESP® and ESP® OFF warning lamps are lit while the engine is running.</p>	<p>ESP®, BAS PLUS, PRE-SAFE®, PRE-SAFE® Brake, COLLISION PREVENTION ASSIST, the HOLD function, hill start assist, crosswind driving assistance, the adaptive brake lights and ESP® trailer stabilisation are unavailable due to a malfunction. ATTENTION ASSIST is deactivated.</p> <p> WARNING</p> <p>The brake system continues to function normally, but without the functions listed above. The braking distance in an emergency braking situation can thus increase.</p> <p>If ESP® is not operational, ESP® is unable to stabilise the vehicle. The danger of skidding and having an accident increases.</p> <ul style="list-style-type: none"> ► Observe the additional display messages in the multifunction display. ► Drive on carefully. ► Visit a qualified specialist workshop.

Problem	Possible causes/consequences and ► Solutions
 <p>The yellow ESP[®] and ESP[®] OFF warning lamps are lit while the engine is running.</p>	<p>ESP[®], BAS, PRE-SAFE[®], the HOLD function, hill start assist, cross-wind driving assistance and ESP[®] trailer stabilisation are temporarily not available.</p> <p>The adaptive brake lights, COLLISION PREVENTION ASSIST, BAS PLUS and PRE-SAFE[®] Brake may also have failed.</p> <p>ATTENTION ASSIST is deactivated.</p> <p>Self-diagnosis is not yet complete.</p> <p> WARNING</p> <p>The brake system continues to function normally, but without the functions listed above.</p> <p>The braking distance in an emergency braking situation can thus increase.</p> <p>If ESP[®] is not operational, ESP[®] is unable to stabilise the vehicle. The danger of skidding and having an accident increases.</p> <ul style="list-style-type: none"> ► Carefully drive on a suitable stretch of road, making slight steering movements at a speed above 20 km/h. The functions mentioned above are available again when the warning lamp goes out. <p>If the warning lamp is still on:</p> <ul style="list-style-type: none"> ► Observe the additional display messages in the multifunction display. ► Drive on carefully. ► Visit a qualified specialist workshop.



Problem	Possible causes/consequences and ► Solutions
 <p>The red indicator lamp for the electric parking brake flashes or lights up and/or the yellow warning lamp for the electric parking brake lights up.</p>	<p>► Observe the additional display messages in the multifunction display.</p>
 <p>The red SRS warning lamp is lit while the engine is running.</p>	<p>There is a malfunction in the SRS (Supplemental Restraint System).</p> <p> WARNING</p> <p>The airbags or belt tensioners may either be triggered unintentionally or, in the event of an accident, may not be triggered. This poses an increased risk of injury.</p> <p>► Drive on carefully.</p> <p>► Have SRS checked at a qualified specialist workshop immediately.</p> <p>For further information about the Supplemental Restraint System, see (► page 41).</p>



Engine	
Problem	Possible causes/consequences and ► Solutions
 <p>The yellow engine diagnostics warning lamp lights up while the engine is running.</p>	<p>There may be a fault, for example:</p> <ul style="list-style-type: none"> • in the engine management • in the fuel injection system • in the exhaust system • in the ignition system (for vehicles with petrol engines) • in the fuel system <p>The emission limit values may be exceeded and the engine may be running in emergency mode.</p> <p>► Have the vehicle checked as soon as possible at a qualified specialist workshop.</p> <p>Vehicles with a diesel engine: the fuel tank has been run dry (► page 177).</p> <p>► Start the engine three to four times after refuelling. If the yellow engine diagnostics warning lamp goes out, emergency running mode is cancelled. The vehicle need not be checked.</p>
 <p>The yellow reserve fuel warning lamp lights up while the engine is running.</p>	<p>The fuel level has dropped into the reserve range.</p> <p>Operation of the auxiliary heating is deactivated when the fuel level drops into the reserve range.</p> <p>► Refuel at the nearest filling station.</p>
 <p>The red coolant warning lamp lights up while the engine is running and the coolant temperature gauge is at the start of the scale.</p>	<p>The temperature sensor for the coolant temperature gauge is faulty.</p> <p>The coolant temperature is no longer being monitored. There is a risk of engine damage if the coolant temperature is too high.</p> <p>► Stop the vehicle immediately, paying attention to road and traffic conditions, and switch off the engine. Do not continue driving under any circumstances.</p> <p>► Secure the vehicle against rolling away (► page 181).</p> <p>► Consult a qualified specialist workshop.</p>

Problem	Possible causes/consequences and ► Solutions
 <p>The red coolant warning lamp comes on while the engine is running.</p>	<p>The coolant level is too low.</p> <p>If the coolant level is correct, the airflow to the engine radiator may be blocked or the electric engine radiator fan may be malfunctioning.</p> <p>The coolant is too hot and the engine is no longer being cooled sufficiently.</p> <ul style="list-style-type: none"> ► Observe the additional display messages in the multifunction display. ► Stop the vehicle immediately, paying attention to road and traffic conditions, and switch off the engine. ► Secure the vehicle against rolling away (▷ page 181). ► Leave the vehicle and keep a safe distance from the vehicle until the engine has cooled down. ► Check the coolant level and top up the coolant, observing the warning notes (▷ page 363). ► If you have to top up the coolant frequently, have the engine cooling system checked. ► Make sure that the air supply to the engine radiator is not blocked, e.g. by frozen slush. ► Do not start the engine again until the coolant temperature is under 120 °C. The engine may otherwise be damaged. ► Drive to the nearest qualified specialist workshop. ► Avoid heavy loads on the engine as you do so, e.g. driving in mountainous terrain and stop-start traffic.
 <p>The red coolant warning lamp comes on while the engine is running. A warning tone also sounds.</p>	<p>The coolant temperature has exceeded 120 °C. The airflow to the engine radiator may be blocked or the coolant level may be too low.</p> <p> WARNING</p> <p>The engine is not being cooled sufficiently and may be damaged. Do not drive when your engine is overheated. This can cause some fluids which may have leaked into the engine compartment to catch fire.</p> <p>Steam from the overheated engine can also cause serious burns which can occur just by opening the bonnet.</p> <p>This poses a risk of injury.</p> <ul style="list-style-type: none"> ► Observe the additional display messages in the multifunction display. ► Stop the vehicle immediately, paying attention to road and traffic conditions, and switch off the engine. ► Secure the vehicle against rolling away (▷ page 181).

Problem	Possible causes/consequences and ► Solutions
	<ul style="list-style-type: none"> ► Leave the vehicle and keep a safe distance from the vehicle until the engine has cooled down. ► Check the coolant level and top up the coolant, observing the warning notes (▷ page 363). ► If you have to top up the coolant frequently, have the engine cooling system checked. ► Make sure that the air supply to the engine radiator is not blocked, e.g. by frozen slush. ► If the coolant temperature is below 120 °C, you can continue driving to the nearest qualified specialist workshop. ► Avoid heavy loads on the engine as you do so, e.g. driving in mountainous terrain and stop-start traffic.

Driving systems

Problem	Possible causes/consequences and ► Solutions
 <p>The red distance warning function warning lamp comes on while the vehicle is moving.</p>	<p>The distance to the vehicle in front is too small for the speed selected.</p> <ul style="list-style-type: none"> ► Increase the distance.
 <p>The red distance warning function warning lamp comes on while the vehicle is moving. A warning tone also sounds.</p>	<p>You are approaching a vehicle or a stationary obstacle in your line of travel at too high a speed.</p> <ul style="list-style-type: none"> ► Be prepared to brake immediately. ► Pay careful attention to the traffic situation. You may have to brake or take evasive action. <p>Further information on DISTRONIC PLUS (▷ page 198). Further information on PRE-SAFE® Brake (▷ page 68). Further information on the distance warning function (▷ page 63).</p>

Tyres	
Problem	Possible causes/consequences and ► Solutions
 The yellow tyre pressure monitor warning lamp is on.	<p>The tyre pressure monitor has detected a loss of pressure in at least one of the tyres.</p> <p> WARNING</p> <p>With tyre pressures which are too low, there is a risk of the following hazards:</p> <ul style="list-style-type: none"> • they may burst, especially as the load and vehicle speed increase. • they may wear excessively and/or unevenly, which may greatly impair tyre traction. • the driving characteristics, as well as steering and braking, may be greatly impaired. <p>There is a risk of an accident.</p> <ul style="list-style-type: none"> ► Stop the vehicle without making any sudden steering or braking manoeuvres. Pay attention to the traffic conditions as you do so. ► Secure the vehicle against rolling away (▷ page 181). ► Observe the additional display messages in the multifunction display. ► If there is a flat tyre, inspect the tyres (▷ page 378). ► Check the tyre pressure (▷ page 402). ► If necessary, correct the tyre pressure.

Useful information	338
Stowage areas	338
Features	346

Useful information

- i** This Owner's Manual describes all models, series and optional equipment for your vehicle that were available at the time of going to press. National variations are possible. Note that your vehicle may not be equipped with all of the functions described. This is also the case for systems and functions relevant to safety.
- i** Read the information on qualified specialist workshops: (▷ page 25).

Stowage areas

Loading guidelines

WARNING

Secure and position the load as described in the loading guidelines.

Otherwise, vehicle occupants could be injured by the load being thrown around in the event of sharp braking, a sudden change in direction or an accident.

You will find further information in the "Securing a load" section.

Even if you follow all the loading guidelines, the load will increase the risk of injury in the event of an accident.

WARNING

Keep the tailgate closed when the engine is running. Otherwise, you could be poisoned by exhaust fumes entering the vehicle.

The handling characteristics of a laden vehicle are dependent on the distribution of the load within the vehicle. For this reason, you should observe the following notes when transporting a load:

- when transporting a load, never exceed the maximum permissible gross vehicle weight

or the permissible axle loads for the vehicle (including occupants).

- position heavy loads as far forwards as possible and as low down in the load compartment as possible.
- the load must not protrude above the upper edge of the seat backrests.
- always place the load against the rear or front seat backrests. Make sure that the seat backrests are securely locked into place.
- hook in the safety net when loading.
- always place the load behind unoccupied seats if possible.
- secure the load with sufficiently strong and wear-resistant lashing material. Pad sharp edges for protection.

- i** Load restraints are available at any qualified specialist workshop, e.g. a Mercedes-Benz Service Centre.

Stowage compartments

Important safety notes

WARNING

The stowage compartments must be closed when items are stored in them. Luggage nets are not designed to secure heavy items of luggage.

You or other vehicle occupants could be injured by objects being thrown around if you:

- brake sharply
- change direction suddenly
- are involved in an accident

Sharp-edged and fragile objects must not be placed in the luggage net.

Glove compartment

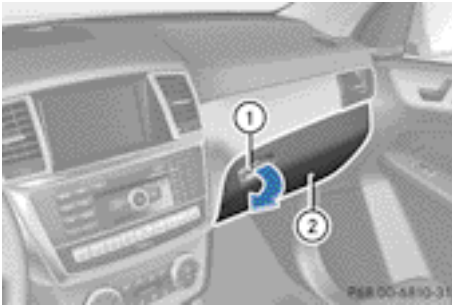

- ▶ **To open:** pull handle ① and open glove compartment flap ②.
- ▶ **To close:** fold glove compartment flap ② upwards until it engages.

i The glove compartment can be cooled and ventilated (▶ page 154).



- 1 Glove compartment unlocked
- 2 Glove compartment locked

The glove compartment can be locked and unlocked using the emergency key element.

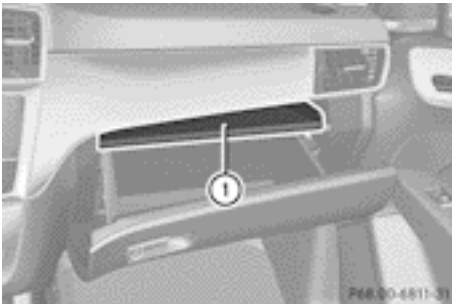

A partition ① for stowing flat objects is located in the upper section of the glove compartment. It can be removed to increase the stowage space in the glove compartment.

- ▶ **To remove:** pull partition ① forwards and out
- ▶ **To install:** insert partition ① and push it back until it engages.

Stowage compartment/telephone compartment under the armrest

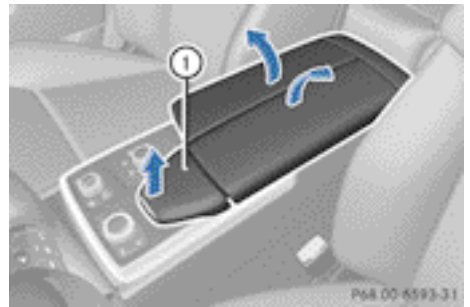

- ▶ **To open:** pull handle ① up. The armrest folds out.

In the stowage compartment, there is a stowage tray and a mobile phone bracket.

i Depending on the vehicle's equipment, a USB port and an AUX-IN jack or a Media Interface are installed in the stowage compartment.

Media Interface is a universal interface for mobile audio equipment, e.g. for an iPod® or MP3 Player.

i There is a removable stowage tray in the storage compartment, in which objects such as an iPod® can be stored.

Spectacles compartment



- ▶ **To open:** press marking ①.
The spectacles compartment opens downwards.
- ▶ **To close:** press marking ① again, the spectacles compartment returns upwards and engages.

Make sure that the spectacles compartment is closed while the vehicle is in motion.

Stowage compartment in the front centre console

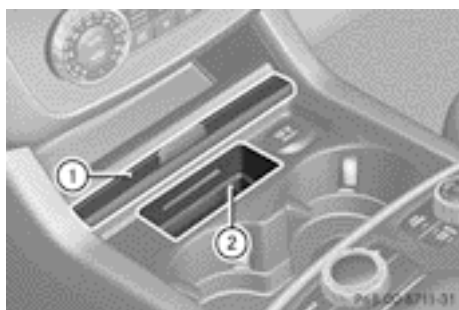

- ▶ **To open:** slide cover ① forwards. Stowage compartment ② appears.
- ▶ **To close:** pull cover ① back as far as it will go.

Stowage compartment in the rear centre console



- ▶ **To open:** briefly press the stowage compartment marking.
The stowage compartment opens.
- ⓘ Depending on the vehicle's equipment, there may be open stowage spaces above and below the stowage compartment.

Stowage nets

⚠ WARNING

Only place lightweight items in the stowage net. Do not use it to transport heavy, bulky, sharp-edged or fragile objects. In the event of an accident, the stowage net will not secure the transported goods sufficiently.

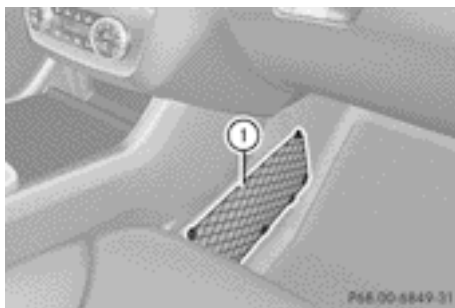

- ① Stowage net in front-passenger footwell



① Stowage net on the back of the front seats

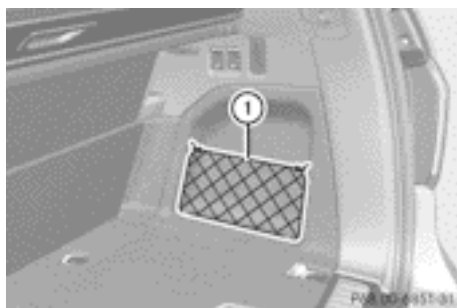

① Stowage net in luggage compartment

Through-loading facility in the rear compartment

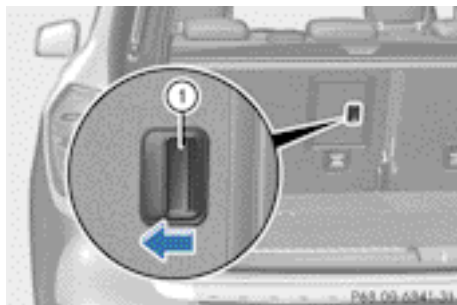

The through-loading facility is opened from the luggage compartment.

- ▶ Release the seat backrests in the second row of seats and tilt them in the cargo/load position (▷ page 104).
- ▶ Fold down the rear seat armrest.

- ▶ Pull the centre head restraint on the rear bench seat into the uppermost position (▷ page 102).
- ▶ Slide release catch ① to the left and swing flap ② to the left until it is lying on the rear side of the rear bench seat.

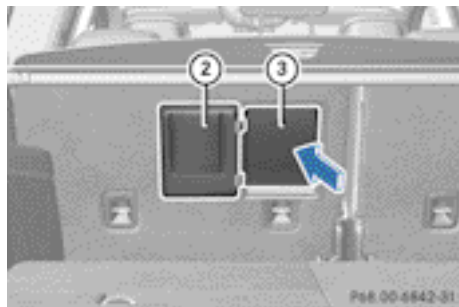

- ▶ Push cover ③ forward until it is lying on the rear seat armrest.

Enlarging the luggage compartment

Important safety notes

WARNING

Do not carry heavy or hard objects inside the vehicle or in the luggage compartment unless they are secured.

Otherwise, you and other vehicle occupants could be injured by objects being thrown around the vehicle in the event of sharp braking, a sudden change in direction or an accident.

When using the luggage compartment enlargement, you should always clip in the safety net, if at hand.

WARNING

Always drive with the tailgate closed. Exhaust fumes could otherwise enter the vehicle interior.

WARNING

Do not fold the backrest onto the folded-down seat cushions. If the seat cushions are folded

down, luggage can be thrown over the backrest into the passenger compartment, e.g. during heavy braking, sudden changes of direction or in the event of an accident. You could cause an accident or cause injury to yourself and others.

! Release and fold the seat cushion upwards before folding the rear bench seat forward. Otherwise, the backrests may be damaged.

When the backrest is folded forwards, the front seats cannot be moved to their rearmost position. Otherwise, the front seats and the rear bench seat could be damaged.

The left-hand and right-hand backrests in the 2nd row of seats can be folded forwards separately to increase the luggage compartment capacity.

On vehicles with a 3rd row of seats, you must fold down the 3rd row of seats beforehand (▷ page 105) to obtain maximum luggage compartment enlargement.

Folding the rear bench seat forwards

! The backrest is heavy. Therefore, exercise care when folding it down. Make sure that the head restraints are pushed all the way in so that the backrests and seat cushions are not damaged.

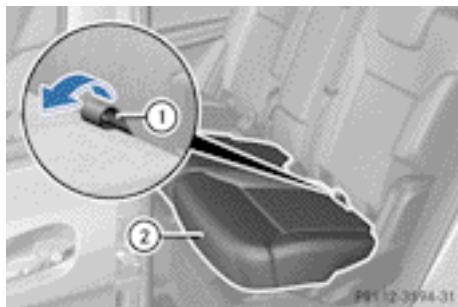

i If the driver's or front-passenger seat is set for a larger person, it may not be possible to fold the rear bench seat forwards. In this case, move the front seats as far forward as possible.

- ▶ Move the head restraints to the lowest position (▷ page 103).
- ▶ Pull release loop (1) of seat cushion (2).
- ▶ Fold seat cushion (2) upwards.

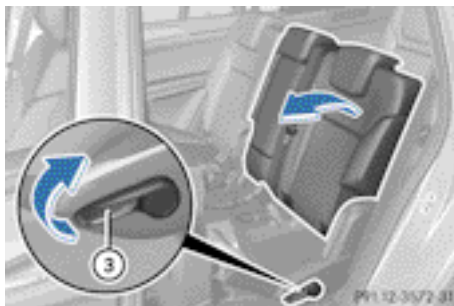

- ▶ Pull release handle (3) in the direction of the arrow. The backrest is released.
- ▶ Fold the backrest forwards until it reaches the luggage compartment position.

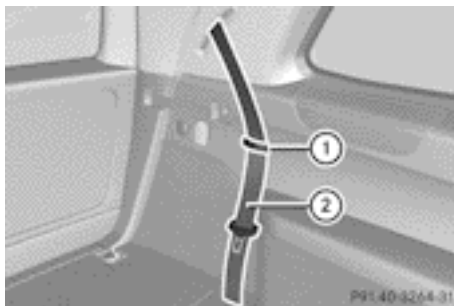

- ▶ Guide seat belts (2) under respective clips (1).

Folding the rear bench seat back

! WARNING

Make sure that the seat backrest and the seat cushion are correctly engaged in position.

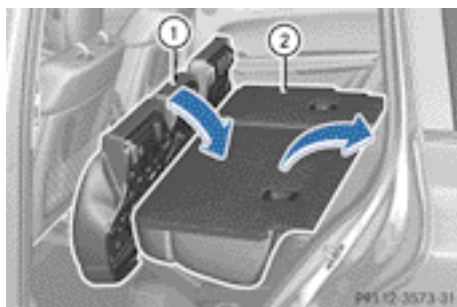

- ▶ Fold seat backrest ② back until it engages. Make sure not to trap the seat belt while doing so.
- ▶ Swing seat cushion ① back.
- ▶ Pull up and adjust the head restraints if necessary (▷ page 103).

Securing a load

Lashing eyelets

General notes

WARNING

Distribute the load on the lashing eyelets evenly.

Otherwise, vehicle occupants could be injured by objects being thrown around if you:

- brake sharply
- change direction suddenly
- are involved in an accident

Please observe the loading guidelines.

Observe the following notes on securing loads:

- secure the load using the lashing eyelets.
- do not use elastic straps or nets to secure a load, as these are only intended as an anti-slip protection for light loads.
- do not route lashing materials across sharp edges or corners.
- Pad sharp edges for protection.

Luggage compartment

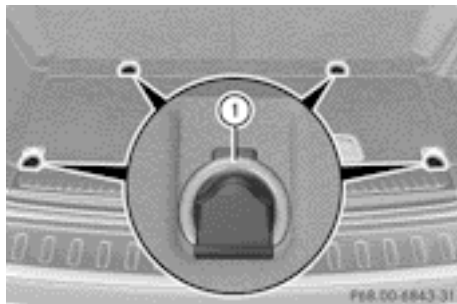

There are four lashing eyelets ① in the luggage compartment.

Bag hook

WARNING

Only hang light loads on the bag holders. Do not use them to transport heavy, sharp-edged or fragile objects. When braking sharply, changing direction quickly or in the event of an accident, the bag hooks will not secure the items sufficiently. This could result in injury to yourself or others.

 The bag hook can bear a maximum load of 3 kg. Do not use it to secure a load.

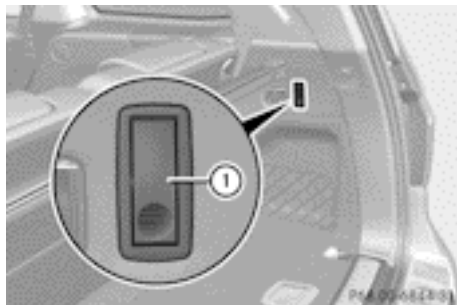

There is a bag hook in the luggage compartment on the right-hand side.

- ▶ Press bag hook marking ①.
- ▶ Turn bag hook ① until it engages.

Luggage compartment cover

Important safety notes

WARNING

The luggage compartment cover is not a restraint system. Secure the load under the luggage compartment cover by suitable means. Make sure that the luggage compartment cover is engaged securely. If luggage is not sufficiently secured, it can be thrown over the backrest into the passenger compartment, for instance during heavy braking, sudden changes of direction or in the event of an accident. You could cause an accident or cause injury to yourself and others.

! When loading the vehicle, make sure that you do not stack the load in the luggage compartment higher than the lower edge of the side windows. Do not place heavy objects on top of the luggage compartment cover.

The luggage compartment cover may be installed behind the 2nd or 3rd row of seats.

Extending and retracting the luggage compartment cover

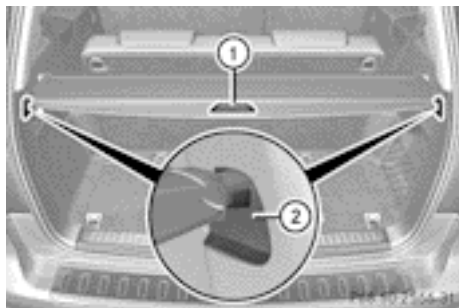

- ▶ **To extend:** pull the luggage compartment cover back by grab handle ① and clip it into retainers ② on the left and right.
- ▶ **To retract:** unhook the luggage compartment cover from left-hand and right-hand retainers ②.
- ▶ Guide luggage compartment cover forwards by grab handle ① until it is completely rolled up.

Coat hooks on the tailgate

WARNING

The tailgate may close if too great a load is placed on the coat hooks.

This could cause you or others to be trapped and injured.

If you use the coat hooks, only hang light clothing on them. Make sure that nobody can become trapped.

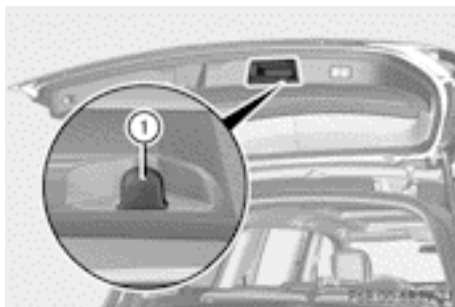

① Coat hook

Stowage well underneath the luggage compartment floor

WARNING

Never drive with the luggage compartment floor open.

Otherwise, you and other vehicle occupants could be injured by objects being thrown around the vehicle in the event of sharp braking, a sudden change in direction or an accident.

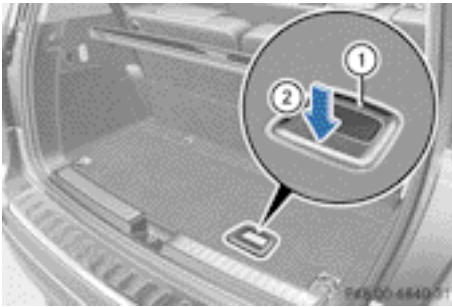

The TIREFIT kit, tyre-change tool kit, etc. are located in the stowage compartment.

- ▶ **To open:** holding the ribbing, press handle ① downwards ②. Handle ① folds upwards.
- ▶ Swing the luggage compartment floor upwards using handle ① until it rests against the luggage compartment cover.

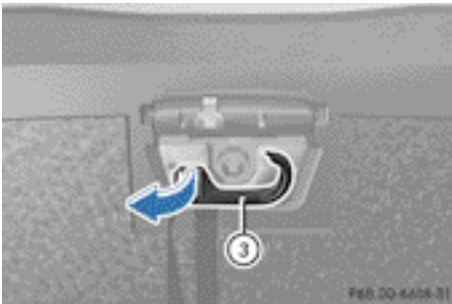

- ▶ Fold out hook ③ on the underside of the luggage compartment floor in the direction of the arrow.

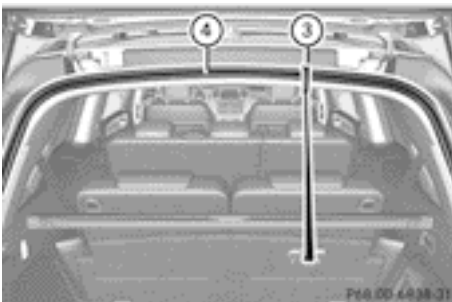

- ▶ Attach hook ③ to the luggage compartment's upper seal ④.
- ▶ **To close:** detach hook ③ from the luggage compartment's upper seal ④.
- ▶ Fasten hook ③ to the bracket on the underside of the luggage compartment floor.
- ▶ Fold the luggage compartment floor down.
- ▶ Press the luggage compartment floor down ② until it engages.

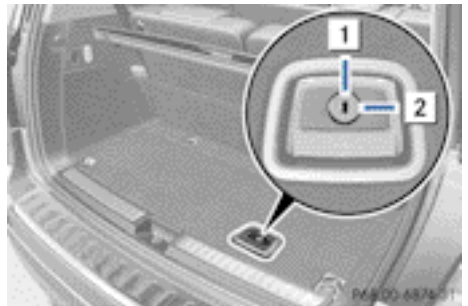

- ① Luggage compartment floor unlocked
- ② Luggage compartment floor locked

The luggage compartment floor can be locked and unlocked using the emergency key element.

Roof carrier

Important safety notes

⚠ WARNING

An incorrectly secured roof carrier, ski rack or load could become detached from the vehicle. These objects might then be thrown around, and could injure you or others or cause an accident. Follow the roof carrier/ski rack manufacturer's installation instructions and special instructions for use.

The roof load raises the vehicle's centre of gravity, thereby affecting vehicle handling. You must always observe the maximum roof load of 100 kg. Always adapt your driving style to the prevailing road, traffic and weather

conditions and drive with particular care if the roof is laden.

! Mercedes-Benz recommends that you only use roof carriers that have been tested and approved for Mercedes-Benz vehicles. This helps to prevent damage to the vehicle.

Position the load on the roof carrier in such a way that the vehicle will not sustain damage even when it is in motion.

Depending on the vehicle equipment, ensure that when the roof carrier is fitted you can:

- raise the sliding sunroof fully
- open the panorama sliding sunroof fully
- open the tailgate fully

Attaching the roof carrier



- ▶ Secure the roof carrier to roof rails ①. In doing so, observe the manufacturer's installation instructions.

Features

Cup holders

Important safety notes

! WARNING

Keep the cup holder closed while the vehicle is in motion. Otherwise, vehicle occupants could be injured by objects being thrown around if you:

- brake sharply
- change direction suddenly
- are involved in an accident

Only use the cup holders for containers of a suitable size and which have lids. The drinks could otherwise spill.

Cup holders should not be used for hot drinks. You may otherwise scald yourself.

! WARNING

Do not transport any heavy, sharp-edged or fragile bottles in the stowage compartments. In the event of an accident, the stowage compartments cannot secure the bottles adequately. You and/or other vehicle occupants could be injured.

The stowage compartments in the doors provide space for bottles with a capacity of up to 1.0 l.

The bottles are not secured or prevented from tipping over. Therefore, do not place any open drink containers in the stowage compartments.

Cup holder in the front centre console

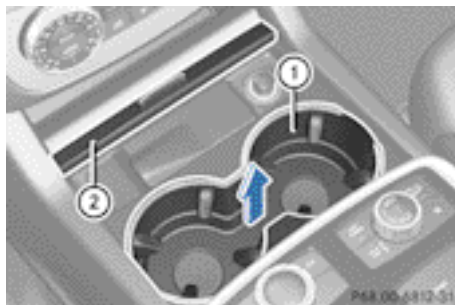

- ① Cup holders
- ② Cover

- ▶ **To open:** slide cover ② to its foremost position.
- ▶ **To close:** pull cover ② back as far as it will go.

You can remove the rubber mat of the cup holder to clean it. Clean it with clean, luke-warm water only.

Temperature-controlled cup holder in the front-compartment centre console

WARNING

When you use the warming function, the metal insert of the cup holder is heated. Therefore, do not touch the cup holder insert. Otherwise, you might burn yourself.

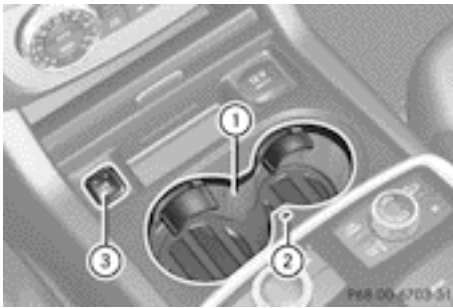

- ① Cup holders
- ② Residual heat indicator lamp
- ③ Button

The temperature-controlled cup holder can be used to keep cold drinks cold and hot drinks hot.

- ▶ Turn the key to position **2** in the ignition lock.
- ▶ **To switch on the cooling function:** press and hold button **③** until the blue indicator lamp on the button lights up.
- ▶ **To switch on the heating function:** press and hold button **③** until the red indicator lamp on the button lights up.
- ▶ **To switch off the function:** press and hold button **③** until the indicator lamp on the button goes out.

When the heating function is used, residual heat indicator lamp **②** lights up from a certain temperature. This means that the metal insert of the cup holder is hot.

Cup holder in the rear seat armrest

- ❗ Do not sit on or support your body weight on the rear seat armrest when it is folded down, as you could otherwise damage it.

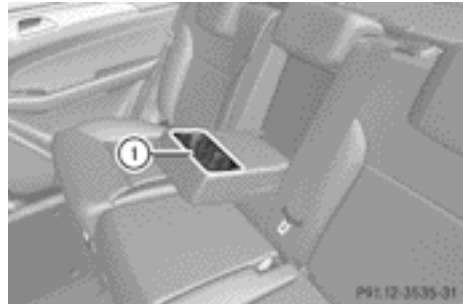

- ▶ Fold down the rear seat armrest. Cup holder **①** is located in the rear seat armrest.

Cup holder in the third row of seats

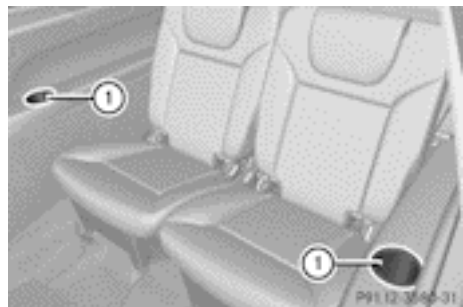

- ① Cup holders

The cup holders are located on the right-hand and left-hand side panels.

Sun visors

Overview

WARNING

Keep the vanity mirrors in the sun visors covered while driving. You could otherwise be dazzled, which may impair your view of traffic conditions and as a result could cause an accident.

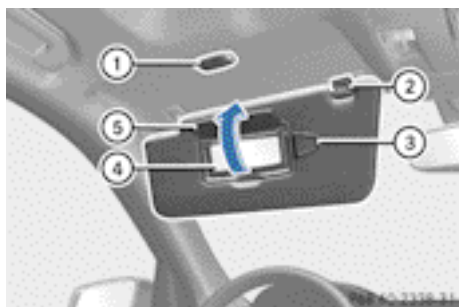

- ① Mirror light
- ② Bracket
- ③ Retaining clip, e.g. for a car park ticket
- ④ Vanity mirror
- ⑤ Mirror cover

Vanity mirror in the sun visor

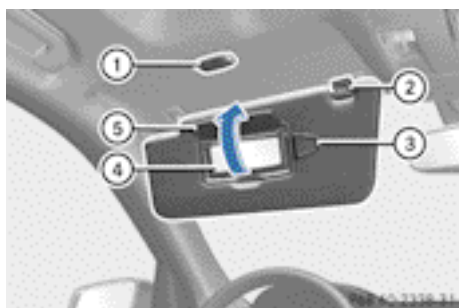

Mirror light ① only functions if the sun visor is clipped into retainer ② and mirror cover ⑤ has been folded up.

Glare from the side

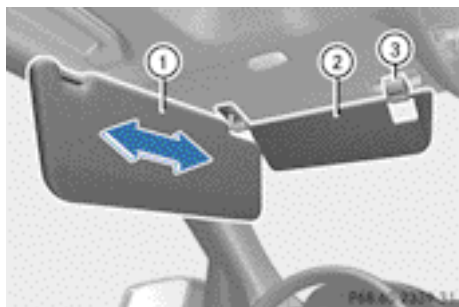

- ▶ Fold down sun visor ①.
- ▶ Pull sun visor ① out of retainer ③.
- ▶ Swing sun visor ① to the side.
- ▶ Slide sun visor ① horizontally as required.
- ▶ Fold down additional sun visor ② to the windscreen.

Sunblinds on the rear side windows

- ⚠ Always guide the roller sunblind by hand. Do not let it snap back suddenly as this would damage the automatic roller mechanism.
- ⚠ Do not drive the vehicle with the roller sunblind hooked in and the side windows opened simultaneously. The roller sunblind can jump out of the retainers and spring back suddenly when driving at high speeds, e.g. when driving on the motorway. This could damage the inertia reel. Therefore, either close the side window or retract the roller sunblind before driving at high speeds.

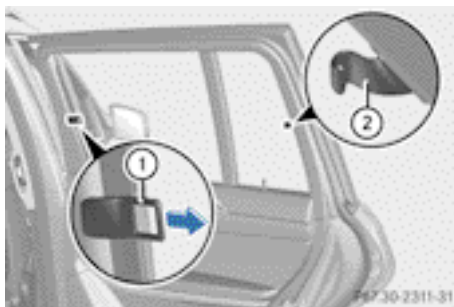

- ▶ **To extend:** pull the roller sunblind out by tab ① and hook it onto retainers ② at the back of the window.

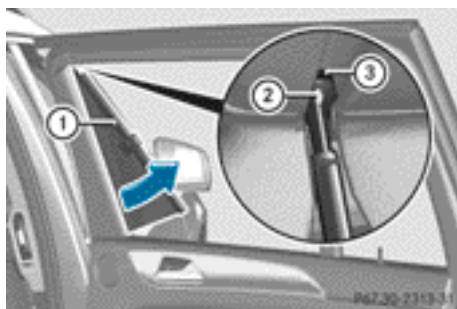

The roller sunblind can be hooked back into place should it pop out from the top of the guide rail.

- ▶ Tilt pull-out profile ① as illustrated.
- ▶ Slip guide bush ② into open area of guide rail ③.
- ▶ Straighten pull-out profile ① again.

Ashtray

Front ashtray

! The holder under the ashtray is not heat resistant. Before placing lit cigarettes in the ashtray, make sure that the ashtray is properly engaged. Otherwise, the holder could be damaged.

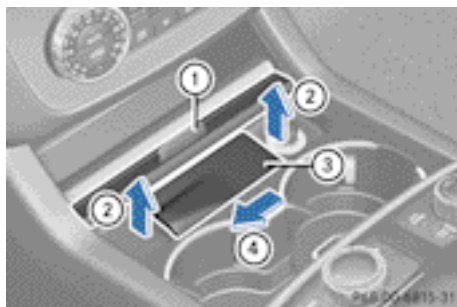

- ▶ **To open:** slide cover ① to its foremost position.
- ▶ Fold cover ③ of the insert upwards.
- ▶ **To remove the insert:** push insert ③ to the left ④.
Insert ③ slides out slightly to the right.

- ▶ Lift insert ③ up ② and out.
- ▶ **To refit the insert:** place insert ③ into the holder and press it down on the right until it engages.
- ▶ **To close:** pull cover ① back as far as it will go.

Rear-compartment ashtray

! Close the ashtray when it is not in use and before you fold the rear seats forward. You can otherwise damage the ashtray.

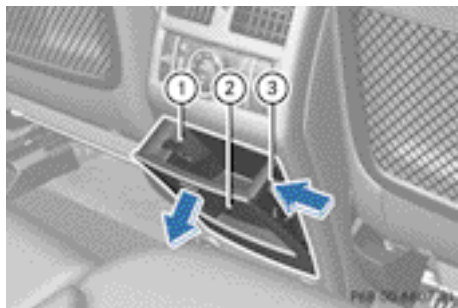

- ▶ **To open:** briefly press cover ② at the top. The ashtray opens.
- ▶ **To remove the insert:** push into recess ③ from the right. Ashtray insert ① slides out slightly to the right.
- ▶ Lift insert ① up and out.
- ▶ **To refit the insert:** place insert ① into the holder and press down on the right until it engages.

Vehicles without a Rear Seat Entertainment System have an ashtray in the centre console in the rear compartment.

Cigarette lighter

⚠ WARNING

Only hold the hot cigarette lighter by its knob. Otherwise, you might burn yourself.

Make sure that children travelling in the vehicle are not able to injure themselves on the hot cigarette lighter or cause a fire with it.

- ❗ The cigarette lighter in the centre console in the front compartment is not intended for operating the tyre inflation compressor.

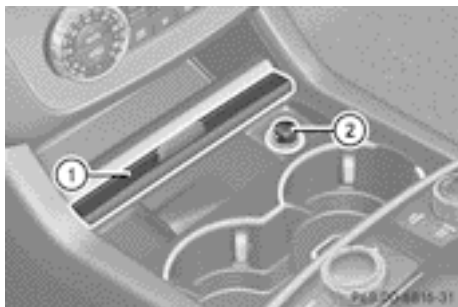

- ▶ Turn the key to position **2** in the ignition lock.
- ▶ **To open:** slide cover **1** to its foremost position.
- ▶ Press in cigarette lighter **2**. Cigarette lighter **2** will pop out automatically when the heating element is red-hot.
- ▶ **To close:** pull cover **1** back as far as it will go.

12 V sockets

General notes

- ▶ Turn the key to position **1** in the ignition lock.

With the exception of the socket in the front centre console, all sockets can be used for accessories with a maximum current draw of 240 W (20 A). The socket in the front centre console can be used for accessories with a maximum current draw of 180 W (15 A). Accessories include such items as lamps or chargers for mobile phones.

If you use the sockets for long periods when the engine is switched off, the battery may discharge.

- ❗ An emergency cut-off ensures that the on-board voltage does not drop too low. If the on-board voltage is too low, the power to the sockets is automatically cut. This ensures that there is sufficient power to start the engine.

Socket in the front centre console

- ❗ The socket is not intended for operating the tyre inflation compressor.

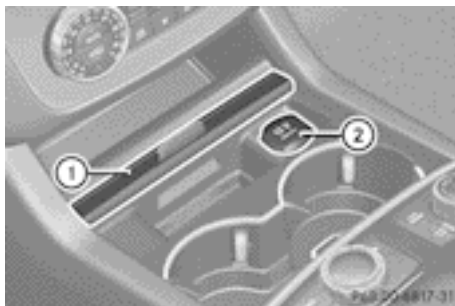

- ▶ **To open:** slide cover **1** to its foremost position.
- ▶ Lift up the cover of socket **2**.
- ▶ **To close:** pull cover **1** back as far as it will go.

Socket in the rear-compartment centre console



- ▶ Lift up the cover of socket **1**.

On vehicles with the Rear Seat Entertainment System, there are two sockets in the rear-compartment centre console.

Socket in the luggage compartment

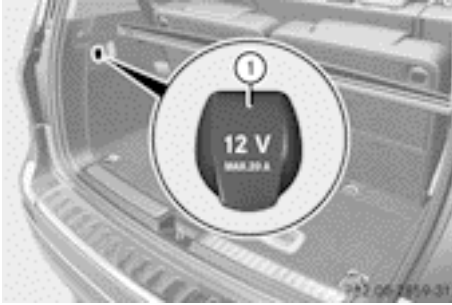

- Lift up the cover of socket ①.

Mobile phone

Important safety notes

WARNING

Observe the legal requirements of the country in which you are currently driving regarding operating mobile communications equipment in a vehicle.

If it is permitted by law to operate communications equipment while the vehicle is in motion, you must only do so if the traffic situation permits. Otherwise, you could be distracted from the traffic conditions, cause an accident and injure yourself and others.

Two-way radios and fax equipment used without low-reflection exterior aerials can interfere with the vehicle's electronics and thereby jeopardise the operating safety of the vehicle and your safety. Therefore, you must only use this equipment if it is correctly connected to a separate reflection-free exterior aerial.

WARNING

Excessive levels of electromagnetic radiation may cause damage to your health and the health of others. Using an exterior aerial takes into account current scientific discussions relating to the possible health risk posed by electromagnetic fields.

Mercedes-Benz recommends the use of an approved exterior aerial. This ensures:

- optimal mobile phone reception quality in the vehicle
- mutual influences between the vehicle electronics and mobile phones are minimised

An exterior aerial has the following advantages:

- it conducts the electromagnetic fields generated by a wireless device to the exterior.
- the field strength in the vehicle interior is lower than in a vehicle that does not have an exterior aerial.

 There are various mobile phone brackets that may be fitted in your vehicle; in some cases, these are country-specific.

 You can connect a Bluetooth®-capable mobile phone with Audio 20 or COMAND Online via the Bluetooth® interface. This also applies if your vehicle is equipped with convenience telephony.

More information on suitable mobile phones, mobile phone brackets and on connecting Bluetooth®-capable mobile phones with Audio 20 or COMAND Online can be obtained:

- at your Mercedes-Benz Service Centre
- on the Internet at <http://www.mercedes-benz.com/connect>

 The functions and services available when you use the phone depend on your mobile phone model and service provider.

Using a mobile phone



If the mobile phone is inserted in the mobile phone bracket, you can speak to the person you are calling using the hands-free system.

- Open the telephone compartment (▷ page 339).
- Insert the mobile phone into the mobile phone bracket (see the separate installation instructions for the mobile phone fitting).

i On some mobile phone brackets, you first have to connect the mobile phone via Bluetooth® to the mobile phone bracket (see the separate operating instructions for the mobile phone bracket).

If this is the case, the mobile phone does not have to be inserted into the bracket for you to be able to use the telephone functions. However, the charging function and aerial function are not available.

Operating the mobile phone

You can operate the telephone using the  and  buttons on the multifunction steering wheel. You can operate other mobile phone functions via the on-board computer (▷ page 275).

When you remove the key from the ignition lock, the mobile phone stays switched on. However, you can no longer use the hands-free system.

If you have an active call and would like to take the key out of the ignition lock, first remove the mobile phone from the bracket.

i When using a bracket connected to the mobile phone via Bluetooth® and you wish to proceed with a call:

Switch to private mode before removing the key from the ignition lock. Otherwise, it may take up to 20 seconds before the mobile phone separates from the system. Only then can the telephone call continue. Information on the necessary steps for setting up "private mode" can be found in the separate mobile phone operating instructions.

i Not all mobile phones support "private mode".

Garage door opener

Important safety notes

The HomeLink® garage door opener integrated in the rear-view mirror allows you to operate up to three different door and gate systems.

i The garage door opener is only available for certain countries. Observe the legal requirements for each individual country.

The HomeLink® garage door opener is compatible with most European garage and gate opener drives. More information on HomeLink® and/or compatible products is available from:

- at a qualified specialised workshop
- the HomeLink® hotline
(0) 08000 466 354 65 (free of charge) or
+49 (0) 6838 907 277 (charges apply)
- on the Internet at:
<http://www.homelink.com>

Programming

Programming buttons

WARNING

Only press the button on the integrated garage door opener if there are no persons or objects present within the sweep of the garage door. Persons could otherwise be injured as the door moves.

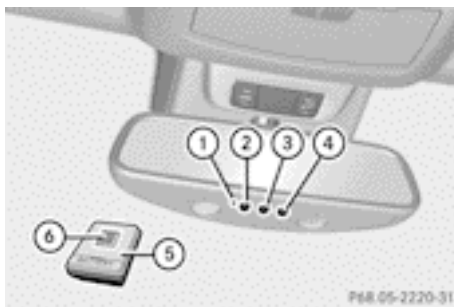

Integrated garage door opener in the rear-view mirror

Garage door remote control ⑤ is not part of the integrated garage door opener.

▶ Before programming for the first time, clear the memory of the integrated garage door opener (▷ page 354).

▶ Turn the key to position **2** in the ignition lock.

▶ Press and hold one of buttons ② to ④ on the integrated garage door opener. After a short time, indicator lamp ① lights up yellow.

i Indicator lamp ① lights up yellow as soon as button ②, ③ or ④ is programmed for the first time. If the selected button has already been programmed, indicator lamp ① will only light up yellow after ten seconds have elapsed.

▶ Release button ②, ③ or ④. Indicator lamp ① flashes yellow.

▶ Point garage door remote control ⑤ towards buttons ② to ④ on the rear-view mirror at a distance of 5 to 20 cm.

i The required distance between remote control ⑤ and the integrated garage door opener depends on the garage door drive system. Several attempts may be required. You should test every position for at least 25 seconds before trying another position.

▶ Press and hold button ⑥ on remote control ⑤ until indicator lamp ① lights up green. If indicator lamp ① lights up green or flashes, then programming has been successful.

▶ Release button ⑥ of garage door drive remote control ⑤.

▶ If indicator lamp ① lights up red: repeat the programming procedure for the corresponding button on the rear-view mirror. When doing so, vary the distance between remote control ⑤ and the rear-view mirror.

i If the indicator lamp flashes green after successful programming, the garage door system is using a rolling code. After pro-

gramming, you must synchronise the garage door opener integrated in the rear-view mirror with the receiver of the garage door system.

Synchronising the rolling code

Your vehicle must be within range of the garage door or exterior gate drive. Make sure that neither your vehicle nor any persons/objects are present within the sweep of the door or gate.

Observe the safety notes when performing the rolling code synchronisation.

▶ Turn the key to position **2** in the ignition lock.

▶ Press the programming button of the door or gate drive (see the door or gate drive operating instructions, e.g. under "Programming of additional remote controls").

i Usually, you now have 30seconds to initiate the next step.

▶ Press previously programmed button ②, ③ or ④ of the integrated garage door opener until the door closes.

The rolling code synchronisation is then complete.

Problems when programming

If you have problems when programming the integrated garage door opener, please note the following:

- Check the transmitter frequency of garage door drive remote control ⑤. This can usually be found on the back of the remote control.
- Replace the batteries in garage door remote control ⑤. This increases the likelihood that garage door remote control ⑤ will transmit a strong and precise signal to the integrated garage door opener in the rear-view mirror.
- When programming, hold remote control ⑤ at varying distances and angles from the button which you are programming. Try various angles at a distance between 5 and

30 cm or at the same angle but at varying distances.

- If there is another remote control for the same garage door drive, perform the programming steps again using this remote control. Before performing these steps, make sure that new batteries have been fitted in garage door drive remote control ⑤.
- Note that some remote controls transmit only for a limited period (the indicator lamp on the remote control goes out). Press button ⑥ on remote control ⑤ again before transmission ends.
- Align the aerial cable of the garage door opener unit. This can improve signal reception/transmission.

Opening or closing the garage door

Once programmed, the integrated garage door opener will assume the function of the garage door system's remote control. Please also read the operating instructions for the garage door system.

- ▶ Turn the key to position **2** in the ignition lock.
- ▶ Press button ②, ③ or ④ which you have programmed to operate the garage door. Garage door system with a fixed code: indicator lamp ① lights up green.

Garage door system with a rolling code: indicator lamp ① flashes green.

- ❗ The transmitter will transmit a signal for as long as the button is pressed. The transmission is halted after a maximum of ten seconds and indicator lamp ① lights up yellow. Press button ②, ③ or ④ again if necessary.

Clearing the memory

- ▶ Turn the key to position **2** in the ignition lock.
- ▶ Press buttons ② and ④.
The indicator lamp lights up yellow.
- ▶ Press and hold buttons ② and ④ until the indicator lamp turns green.

- ❗ Make sure that you clear the memory of the integrated garage door opener before selling the vehicle.

Frequencies

Europe

Country	Radio type approval number Frequency range (MHz)
AD (Andorra)	20 July MHz: 27, 30, 40, 433, 868
AT (Austria)	Article 6 of Directive 1999/5/EC R&TTE 18 May 05 MHz: 27, 40, 433, 868
BE (Belgium)	Article 6 of Directive 1999/5/EC R&TTE 18 May 05 MHz: 27, 40, 433, 868
BG (Bulgaria)	Article 6 of Directive 1999/5/EC R&TTE 12 April 07 MHz: 27, 40, 433, 868
CH (Switzerland)	Article 6 of Directive 1999/5/EC R&TTE 14357 27 May 05 MHz: 27, 40, 433, 868
CY (Cyprus)	Article 6 of Directive 1999/5/EC R&TTE 5 May 05 MHz: 27, 40, 433, 868

Country	Radio type approval number Frequency range (MHz)
CZ (Czech Republic)	General Licence GL-30/R/ 2000 Reg. No. 844 13 May 05 MHz: 27, 40, 433
DK (Denmark)	Article 6 of Directive 1999/5/EC R&TTE 20 April 05 MHz: 27, 40, 433, 868
DE (Germany)	Article 6 of Directive 1999/5/EC R&TTE7519301 29 April 05 MHz: 27, 40, 433, 868
EE (Estonia)	Article 6 of Directive 1999/5/EC R&TTE 11 May 05 MHz: 27, 40, 433, 868
ES (Spain)	000438/2005, 000439/2005, 000440/2005 000441/2005, 000445/2005, 000446/2005 000447/2005 MHz: 27, 40, 433, 868
FI (Finland)	Article 6 of Directive 1999/5/EC R&TTE10668 13 May 05 MHz: 27, 40, 433, 868
FR (France)	Article 6 of Directive 1999/5/EC R&TTE10668 13 May 05 27, 30, 40, 433, 868
GI (Gibraltar)	Article 6 of Directive 1999/5/EC R&TTE13 May 05 (UK) MHz: 27, 40, 418, 433, 868

Country	Radio type approval number Frequency range (MHz)
GR (Greece)	Article 6 of Directive 1999/5/EC R&TTE11409/18/4/2005 18 May 05 MHz: 27, 40, 433, 868
HR (Croatia)	SDR 224/06 MHz: 27, 40, 433, 868
HU (Hungary)	Article 6 of Directive 1999/5/EC R&TTE 18 May 05 MHz: 27, 40, 433, 868
IC (Canary Islands)	000438/2005, 000439/2005 000440/2005, 000441/2005 000445/2005, 000446/2005 000447/2005, 3rd June 2005 MHz: 27, 40, 433, 868
IE (Ireland)	Article 6 of Directive 1999/5/EC R&TTE 18 May 05 MHz: 27, 40, 433, 868
IS (Iceland)	Article 6 of Directive 1999/5/EC R&TTE 18 May 05 MHz: 27, 40, 433, 868

Country	Radio type approval number Frequency range (MHz)
IT (Italy)	DGPGRS/II/347487/ FOR/15347 DGPGRS/II/347487/ FOR/15348 DGPGRS/II/347487/ FOR/15350 DGPGRS/II/347487/ FOR/15357 DGPGRS/II/347487/ FOR/15358 DGPGRS/II/347487/ FOR/15359 MHz: 27, 40, 433, 868
LI (Liechtenstein)	Article 6 of Directive 1999/5/EC R&TTE 14357 27 May 05 MHz: 27, 40, 433, 868
LT (Lithuania)	Article 6 of Directive 1999/5/EC R&TTE27.4-1B-1609 6 May 05 MHz: 27, 40, 433, 868
LU (Luxembourg)	Article 6 of Directive 1999/5/EC R&TTE150405/9538 24 May 05 MHz: 27, 40, 433, 868
LV (Latvia)	Article 6 of Directive 1999/5/EC R&TTE 27.4-1B-1609 26 April 06 MHz: 27, 40, 433, 868
MC (Monaco)	Article 6 of Directive 1999/5/EC R&TTE10668 13 May 05 MHz: 27, 40, 433, 868

Country	Radio type approval number Frequency range (MHz)
MT (Malta)	Article 6 of Directive 1999/5/EC R&TTE 18 May 05 MHz: 27, 40, 433, 868
NL (Netherlands)	Article 6 of Directive 1999/5/EC R&TTE 18 May 05 MHz: 27, 40, 433, 868
NO (Norway)	Article 6 of Directive 1999/5/EC R&TTE05/02424-SA644 18 May 05 MHz: 27, 40, 433, 868
PL (Poland)	Article 6 of Directive 1999/5/EC R&TTE 21 April 05 MHz: 27, 40, 433, 868
PT (Portugal)	ANCOM-S08399/05 27, 40, 433, 868
RO (Romania)	Article 6.4 of Directive 1999/5/EC R&TTE MHz: 27, 30, 40, 433, 868
RU (Russian Federation)	POCC DE.MJ05.H00015 13 May 05 MHz: 433
SE (Sweden)	Article 6 of Directive 1999/5/EC R&TTE 18 May 05 MHz: 27, 40, 433, 868
SI (Slovenia)	Article 6 of Directive 1999/5/EC R&TTE 500-1/2005-437 9 May 05 MHz: 27, 40, 433, 868

Country	Radio type approval number Frequency range (MHz)
SK (Slovakia)	Article 6 of Directive 1999/5/EC R&TTE Slovak 206/11/2005 4 May 05 MHz: 27, 40, 433, 868
UK (United Kingdom)	Article 6 of Directive 1999/5/EC R&TTE 18 May 05 MHz: 27, 40, 418, 433, 868

Africa

Country	Radio type approval number Frequency range (MHz)
EG (Egypt)	W-KLE-17/08 Mar. 06 MHz: 27, 30, 40, 418, 433, 868
RE (Réunion)	Article 6 of Directive 1999/5/EC R&TTE 11 July 05 MHz: 27, 40, 433, 868
ZA (South Africa)	11 October 2005 MHz: 27, 40, 433

America

Country	Radio type approval number Frequency range (MHz)
BB (Barbados)	Registration not required MHz: 27, 40, 433, 868
CL (Chile)	38447/F-23 No.3.3634 MHz: 40, 433
GF (French Guyana)	Article 6 of Directive 1999/5/EC R&TTE10668 13 May 05 MHz: 27, 30, 40, 433, 868

Country	Radio type approval number Frequency range (MHz)
GP (Guadeloupe)	Article 6 of Directive 1999/5/EC R&TTE10668 13 May 05 MHz: 27, 30, 40, 433, 868
MQ (Martinique)	Article 6 of Directive 1999/5/EC R&TTE 11 July 05 MHz: 27, 30, 40, 433, 868
MX (Mexico)	MHz: 280 to 390

Asia

Country	Radio type approval number Frequency range (MHz)
AE (United Arab Emirates)	1623/5/10-2/26/76 MHz: 433
JO (Jordan)	TRC/LPD/2005/23 MHz: 27, 30, 40, 433, 868
KW (Kuwait)	5 October 2005 MHz: 27, 30, 40, 418, 433, 868
LB (Lebanon)	2920/O&M/2006 / 3 July 05 MHz: 27, 40, 433, 868
SA (Saudi Arabia)	11_02_05/5024-5-6 MHz: 418, 433
SY (Syria)	279/4/14 / 05 March 06
TR (Turkey)	National Certification 23 July 07 MHz: 433

Australia

Country	Radio type approval number Frequency range (MHz)
AU (Australia)	28 June MHz: 27, 30, 40, 433, 868
NZ (New Zealand)	20 March 06 MHz: 27, 30, 40, 433

Floormats

 **WARNING**

Make sure that there is sufficient clearance around the pedals when floormats are used, and that the floormats are properly secured. The floormats must be correctly secured at all times using the securing knob and retainers. Before you drive off, check the floormats and secure them if necessary. A floormat which is not properly secured can slip and thereby interfere with the movement of the pedals. Do not place floormats on top of one another.

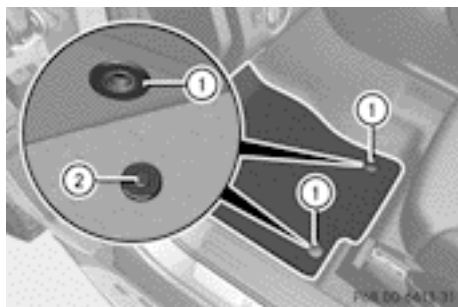

Example: floormat on the driver's side

- ▶ **Driver's and front-passenger seat:** slide the corresponding seat backwards.
- ▶ **Rear seats:** slide the corresponding front seat forwards.
- ▶ **To fit:** lay the floormat in the footwell.
- ▶ Press studs ① onto retainers ②.

- ▶ **To remove:** pull the floormat from retainers ②.
- ▶ Remove the floormats.

Infrared reflective windscreen

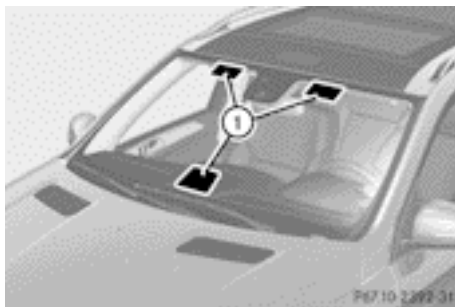

The infrared reflecting glass prevents the vehicle interior from becoming too hot. It also blocks radio waves up into the gigahertz range.

To enable operation of radio-controlled equipment, e.g. toll recording systems, areas on the windscreen are permeable to radio waves ①. In these areas, you can install radio-controlled systems.

These areas can best be seen from outside the vehicle by observing the light reflected off the windscreen.

Retrofitted anti-glare film

Retrofitted anti-glare film on the inside of the windows can interfere with radio/mobile telephone reception. This is particularly the case for conductive or metallic-coated films. You can obtain information about anti-glare film from a qualified specialist workshop.

Useful information	360
Engine compartment	360
Service	364
Care	366

Useful information

- i** This Owner's Manual describes all models, series and optional equipment for your vehicle that were available at the time of going to press. National variations are possible. Note that your vehicle may not be equipped with all of the functions described. This is also the case for systems and functions relevant to safety.
- i** Read the information on qualified specialist workshops: (▷ page 25).

Engine compartment

Bonnet

Active bonnet (pedestrian protection)

Operating principle

! An active bonnet that had been triggered must be repaired at a qualified specialist workshop. The active bonnet function will then be available again. The additional pedestrian protection provided by the active bonnet will then be restored.

- i** The active bonnet is only available in certain countries. It is available for all models, except for AMG vehicles.

The active bonnet can reduce the risk of injury to pedestrians in certain accident situations. Raising the active bonnet increases the clearance to hard components, such as the engine. If the active bonnet has been triggered, it will be raised in the area of the bonnet hinges by approximately 100 mm. The active bonnet is triggered by pyrotechnics.

For the drive to the workshop, reset the triggered active bonnet yourself. After being reset, the active bonnet rests in the area of the bonnet hinges on the seals, and the bonnet hinges do not engage. For this reason, we recommend that you do not exceed a maximum top speed of 130 km/h on the way to the workshop. If the active bonnet has been

triggered, pedestrian protection may be limited.

Resetting

⚠ WARNING

There is a risk of injury if the bonnet is open, even if the engine is not running.

Some engine components can become very hot.

To avoid the risk of burns, only touch those components described in the Owner's Manual and observe the relevant safety notes.

⚠ WARNING

Make sure that nobody can become trapped as you close the bonnet.

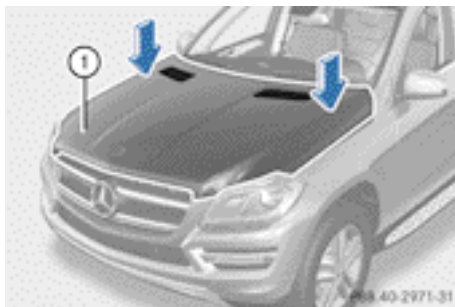

- ▶ With your hand flat near the bonnet hinges (arrows), push down active bonnet ① until it rests on the seals.

Opening the bonnet

⚠ WARNING

Do not pull the release lever while the vehicle is in motion. If you do so, the bonnet may open up and block your view.

⚠ WARNING

There is a risk of injury if the bonnet is open, even if the engine is not running.

Some engine components can become very hot.

To avoid the risk of burns, only touch those components described in the Owner's Manual and observe the relevant safety notes.

WARNING

The radiator fan between the radiator and the engine can start automatically, even if the key has been removed from the ignition lock. For this reason, you must not reach into the fan rotation area. You could otherwise be injured.

Vehicles with a petrol engine: The electronic ignition system uses high voltage. For this reason, you must never touch ignition system components (ignition coil, ignition cables, spark plug connectors or test socket) while:

- the engine is running
- the engine is being started
- the ignition is switched on and the engine is being cranked by hand

You could otherwise suffer an electric shock and be seriously or even fatally injured.

Vehicles with a diesel engine: The electronic injection control uses high voltage. For this reason, you must never touch injection system components while:

- the engine is running
- the engine is being started
- the ignition is switched on

You could otherwise suffer an electric shock and be seriously or even fatally injured.

WARNING

The windscreen wipers and wiper linkage could be set in motion.

When the bonnet is open, you or others could be injured by the wiper linkage.

Make sure that the windscreen wipers are switched off. Remove the key or make sure that no ignition position has been selected with KEYLESS-GO. All indicator lamps must be off in the instrument panel.

-  Make sure that the windscreen wipers are not folded away from the windscreen. Other-

wise, you could damage the windscreen wipers or the bonnet.

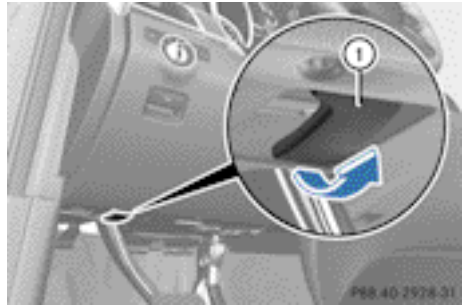

- ▶ Make sure that the windscreen wipers are switched off.
- ▶ Pull release lever ① on the bonnet. The bonnet is released.

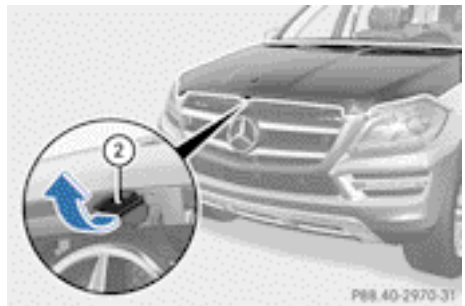

- ▶ Reach into the gap, pull bonnet catch handle ② up and lift the bonnet.

If you lift the bonnet by approximately 40 cm, the bonnet is opened and held open automatically by the gas-filled strut.

Closing the bonnet

WARNING

Make sure that nobody can become trapped as you close the bonnet.

- ▶ Lower the bonnet and let it fall from a height of approximately 20 cm.
- ▶ Check that the bonnet has engaged properly. If the bonnet can be raised slightly, it is not properly engaged. Open it again and close it with a little more force.

Radiator

Vehicles with a diesel engine: do not cover the radiator. Do not use thermal mats, insect protection covers or anything similar. Doing so can cause the Onboard Diagnostics System to display inaccurate values. Some of these values are legally required and must always be correct.

Engine oil

General notes

Depending on your driving style, the vehicle consumes up to 0.8 l of oil per 1,000 km. The oil consumption may be higher than this when the vehicle is new or if you frequently drive at high engine speeds.

Depending on the engine, the oil dipstick may be installed at a different location.

When checking the oil level:

- park the vehicle on a level surface.
- the engine should be switched off for approximately five minutes if the engine is at normal operating temperature.
- if the engine is not at normal operating temperature, e.g. if the engine was only started briefly, wait about 30 minutes before carrying out the measurement.

Checking the oil level using the oil dipstick

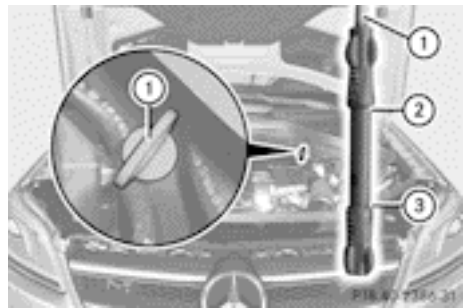

Example: vehicles with a petrol engine

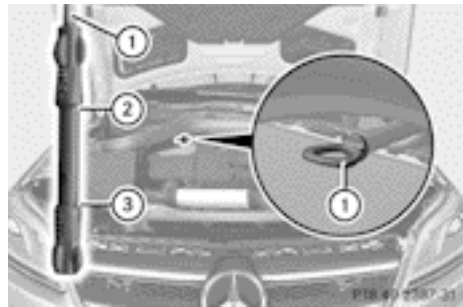

Example: vehicles with a diesel engine

- ▶ Pull oil dipstick ① out of the oil dipstick tube.
- ▶ Wipe off oil dipstick ①.
- ▶ Slowly slide oil dipstick ① into the guide tube to the stop, and take it out again. If the level is between MIN mark ③ and MAX mark ②, the oil level is correct.
- ▶ If the oil level has dropped to MIN mark ③ or below, add 1.0 litre of engine oil.

Adding engine oil

WARNING

If engine oil comes into contact with hot engine parts, it may ignite and you could burn yourself. Do not spill any engine oil on hot engine parts.

Environmental note

When topping up the oil, take care not to spill any. If oil enters the soil or waterways, it is harmful to the environment.

! Only use engine oils and oil filters that have been approved for vehicles with a service system. You can obtain a list of the engine oils and oil filters tested and approved in accordance with the Mercedes-Benz Specifications for Service Products at any Mercedes-Benz Service Centre.

Damage to the engine or exhaust system is caused by the following:

- using engine oils and oil filters that have not been specifically approved for the service system
- changing the engine oil and oil filter after missing the change interval required by the service system
- using engine oil additives

! Do not add too much oil. Topping up with too much engine oil can result in damage to the engine or to the catalytic converter. Have excess engine oil siphoned off.



Example: engine oil filler cap

- ▶ Turn cap ① anti-clockwise and remove it.
- ▶ Top up the engine oil.
If the oil level is at or below the MIN mark on the oil dipstick, add 1.0 litre of engine oil.

- ▶ Replace cap ① on the filler neck and turn clockwise.
Make sure that the cap locks securely into place.
- ▶ Check the oil level again with the oil dipstick (▷ page 362).

For further information on engine oil, see (▷ page 428).

Other service products

Checking the coolant level

⚠ WARNING

The cooling system is pressurised. Therefore, only unscrew the cap once the engine has cooled down. The coolant temperature display must be less than 70 °C. Otherwise, you could be scalded if hot coolant escapes.

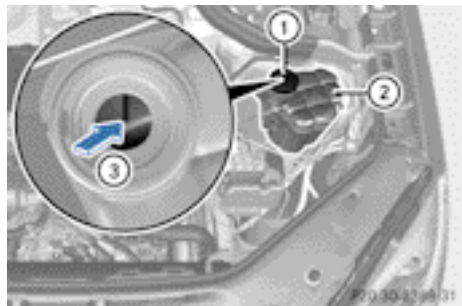

- ▶ Park the vehicle on a level surface.
Only check the coolant level if the vehicle is on a level surface and the engine has cooled down.
- ▶ Turn the key to position 2 in the ignition lock (▷ page 159).
On vehicles with KEYLESS-GO, press the Start/Stop button twice (▷ page 159).
- ▶ Check the coolant temperature gauge in the multifunction display.
The coolant temperature must be below 70 °C.
- ▶ Turn the key to position 0 (▷ page 159) in the ignition lock.

- ▶ Slowly turn cap ① half a turn anti-clockwise to allow excess pressure to escape.
- ▶ Turn cap ① further anti-clockwise and remove it.
If the coolant is at the level of marker bar ③ in the filler neck when cold, there is enough coolant in coolant expansion tank ②.
- ▶ If the coolant level is approximately 1.5 cm above marker bar ③ in the filler neck when warm, there is enough coolant in coolant expansion tank ②.
- ▶ If necessary, top up with coolant that has been tested and approved by Mercedes-Benz.
- ▶ Replace cap ① and turn it clockwise as far as it will go.

For further information on coolant, see (▷ page 429).

Topping up the windscreen washer system/headlamp cleaning system

WARNING

Windscreen washer fluid/antifreeze is highly flammable. Avoid spilling windscreen washer fluid/antifreeze on hot engine components as it can ignite and burn. Severe burns could be the result.

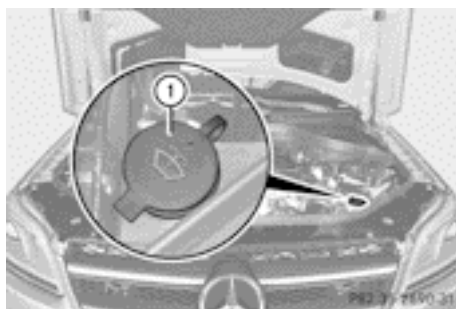

Example: washer fluid reservoir

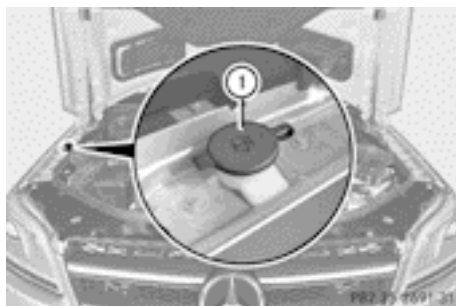

Example: washer fluid reservoir in AMG vehicles

- ▶ **To open:** pull cap ① upwards by the tab.
- ▶ Top up with the premixed washer fluid.
- ▶ **To close:** press cap ① onto the filler neck until it engages.

The washer fluid reservoir is used for both the windscreen washer system and the headlamp cleaning system.

Further information on windscreen washer fluid/antifreeze (▷ page 430).

Service

ASSYST PLUS

Service messages

The ASSYST PLUS service interval display informs you of the next service due date. Information on the type of service and service intervals (see separate Service Booklet). You can obtain further information from a Mercedes-Benz Service Centre.

i The ASSYST PLUS service interval display does not show any information on the engine oil level. Observe the notes on the engine oil level (▷ page 362).

The multifunction display shows a service message for a few seconds, e.g.:

Next service A in .. days

Service A due

Service A overdue by ... days

The letter indicates which service is due. **A** stands for a minor service and **B** for a major service. A number or another letter may be displayed after the letter. This figure indicates any necessary additional maintenance work to be performed.

If you notify a qualified specialist workshop of this display, you will receive a statement on the associated costs.

The ASSYST PLUS service interval display does not take into account any periods of time during which the battery is disconnected.

Maintaining the time-dependent service schedule:

▶ Note down the service due date displayed in the multifunction display before disconnecting the battery.





or

▶ After reconnecting the battery, subtract the battery disconnection periods from the service date shown on the display.

Hiding a service message

▶ Press the  or  button on the steering wheel.

Displaying service messages

- ▶ Switch the ignition on.
- ▶ Press the  or  button on the steering wheel to select the **Serv.** menu.
- ▶ Press the  or  button to select the **ASSYST PLUS** submenu and confirm by pressing the  button.
The service due date appears in the multifunction display.

Information about Service

Resetting the ASSYST PLUS service interval display

! If the ASSYST PLUS service interval display has been inadvertently reset, this setting can be corrected at a qualified specialist workshop.

Have service work carried out as described in the Service Booklet. This may otherwise lead to increased wear and damage to the major assemblies or the vehicle.

A qualified specialist workshop, e.g. a Mercedes-Benz Service Centre, will reset the ASSYST PLUS service interval display after the service work has been carried out. You can also obtain further information on maintenance work, for example.

Special service requirements

Arduous operating conditions or increased loads on the vehicle will require some service work to be performed more often than for a vehicle in normal use. Such arduous conditions include regular city driving with frequent intermediate stops and use in mountainous terrain or on poor road surfaces.

For example, if the vehicle is used under arduous operating conditions, have air filters, engine oil and oil filters changed frequently and check the wheels often. Further information can be obtained at a qualified specialist workshop, e.g. a Mercedes-Benz Service Centre.

Driving abroad

An extensive Mercedes-Benz Service network is also available in other countries. The Service Hotline's current telephone numbers for use when you are abroad are to be found in the "Mercedes-Benz Service24h" section of the Service Booklet.

AdBlue® service display

i For BlueTEC vehicles only.

To function properly, BlueTEC exhaust gas aftertreatment must be operated with the reducing agent AdBlue®. AdBlue® is topped up as part of the service. Under normal operating conditions, a full tank of AdBlue® should last until the next service due date.

Depending on how and where the vehicle is used, there may be an increase in the AdBlue® consumption, resulting in the next service due date being brought forward.

Certain display messages show that AdBlue® must be topped up, e.g.

Refill AdBlue See Owner's Manual
Refill AdBlue No start in: .. km

A warning tone also sounds.

You can no longer start the engine when the AdBlue® supply has been used up (▷ page 306).

Top up AdBlue® (▷ page 178).

Before taking a trip with your vehicle outside Europe, have the AdBlue® supply checked at a qualified specialist workshop. If necessary, have AdBlue® topped up. Before a longer stay outside of Europe, consult a qualified specialist workshop.

Observe the notes on AdBlue® (▷ page 427).

You can obtain further information about BlueTEC exhaust gas aftertreatment and AdBlue® from any Mercedes-Benz Service Centre.

Care

General notes

Environmental note

Dispose of empty packaging and cleaning cloths in an environmentally responsible manner.

! For cleaning your vehicle, do not use any of the following:

- dry, rough or hard cloths
- abrasive cleaning agents
- solvents
- cleaning agents containing solvents

Do not scrub.

Do not touch the surfaces or protective films with hard objects, e.g. a ring or ice scraper. You could otherwise scratch or damage the surfaces and protective film.

! Do not park up the vehicle for an extended period straight after cleaning it, particularly after having cleaned the wheels with wheel cleaner. Wheel cleaners could cause increased corrosion of the brake discs and brake pads/linings. For this reason, you should drive for a few minutes after cleaning. Braking heats the brake discs and the brake pads/linings, thus drying them. The vehicle can then be parked up.

Regular care of your vehicle is a condition for retaining the quality in the long term.

Use care products and cleaning agents recommended and approved by Mercedes-Benz.

Washing the vehicle and cleaning the paintwork

Automatic car wash

WARNING

Braking efficiency is reduced after washing the vehicle. This could cause an accident. For this reason, following a car wash, drive with particular care until the brakes are dry.

⚠ WARNING

The vehicle is braked when the HOLD function or DISTRONIC PLUS is activated. Therefore, deactivate the HOLD function and DISTRONIC PLUS before the vehicle is washed in an automatic car wash.

! Make sure that:

- the side windows and sliding sunroof are closed completely.
- the blower for the ventilation/heating is switched off (OFF button is depressed).
- the windscreen wiper switch is at position **0**.

The vehicle could otherwise be damaged.

! In car washes with a towing mechanism, make sure that the automatic transmission is in transmission position **N**, otherwise the vehicle could be damaged.

- Vehicles with a key:
 - do not remove the key from the ignition lock. Do not open the driver's door or front-passenger door when the engine is switched off. Otherwise, the automatic transmission selects park position **P** automatically and locks the wheels. You can prevent this by shifting the automatic transmission to **N** beforehand.
- Vehicles with KEYLESS-GO:
 - do not open the driver's door or front-passenger door when the engine is switched off. Otherwise, the automatic transmission selects park position **P** automatically and locks the wheels.

Observe the following to make sure that the automatic transmission stays in position **N**:

- ▶ Make sure the vehicle is stationary and the ignition is switched off.
- ▶ Turn the key to position **2** (▷ page 159) in the ignition lock.
 - Use the key instead of the Start/Stop button on vehicles with KEYLESS-GO.
- ▶ Depress and hold the brake pedal.

- ▶ Shift the automatic transmission to position **N**.
- ▶ Release the brake pedal.
- ▶ Release the electric parking brake.
- ▶ Switch off the ignition and leave the key in the ignition lock.

You can wash the vehicle in an automatic car wash from the very start.

Wash off excess dirt before cleaning the vehicle in an automatic car wash.

After using an automatic car wash, wipe off wax from the windscreen and the wiper blades. This will prevent smears and reduce wiping noises caused by residue on the windscreen.

Washing by hand

In some countries, washing by hand is only allowed at specially equipped washing bays. Observe the legal requirements for each individual country.

- ▶ Do not use hot water and do not wash the vehicle in direct sunlight.
- ▶ Use a soft sponge to clean.
- ▶ Use a mild cleaning agent, such as a car shampoo approved by Mercedes-Benz.
- ▶ Thoroughly hose down the vehicle with a gentle jet of water.
- ▶ Do not point the water jet directly towards the air inlets.
- ▶ Use plenty of water and rinse out the sponge frequently.
- ▶ Rinse the vehicle with clean water and dry thoroughly with a chamois.
- ▶ Do not let the cleaning agent dry on the paintwork.

When using the vehicle in winter, remove all traces of road salt deposits carefully and as soon as possible.

High-pressure cleaning equipment

WARNING

Do not use high-pressure cleaners with circular-jet nozzles (dirt grinders) to clean your vehicle, in particular the tyres. You could otherwise damage the tyres and cause an accident.

- !** Always maintain a distance of at least 30 cm between the vehicle and the high-pressure cleaner nozzle. Information about the correct distance is available from the equipment manufacturer.

Move the high-pressure cleaner nozzle around when cleaning your vehicle.

Do not aim directly at any of the following:

- tyres
- door gaps, roof gaps, joints etc.
- electrical components
- battery
- connectors
- lights
- seals
- trim elements
- ventilation slots

Damaged seals or electrical components can lead to leaks or failures.

Cleaning the paintwork

- !** Do not affix:

- stickers
- films
- magnetic plates or similar items

to painted surfaces. You could otherwise damage the paintwork.

Scratches, corrosive deposits, areas affected by corrosion and damage caused by inadequate care cannot always be completely repaired. In such cases, visit a qualified specialist workshop.

- ▶ Remove impurities immediately, where possible, whilst avoiding rubbing too hard.
- ▶ Soak insect remains with insect remover and rinse off the treated areas afterwards.
- ▶ Soak bird droppings with water and rinse off the treated areas afterwards.
- ▶ Remove coolant, brake fluid, tree resin, oils, fuels and greases by rubbing gently with a cloth soaked in petroleum ether or lighter fluid.
- ▶ Use tar remover to remove tar stains.
- ▶ Use silicone remover to remove wax.

Care and treatment of matt paintwork

- !** Never polish the vehicle or the light alloy wheels. Polishing makes the paintwork shiny.

- !** The following may cause the paint to become shiny and thus reduce the matt effect:

- Vigorous rubbing with unsuitable materials.
- Frequent use of car washes.
- Washing the vehicle in direct sunlight.

- !** Never use paint cleaner, buffing or polishing products, or gloss preserver, e.g. wax. These products are only suitable for high-gloss surfaces. Their use on vehicles with matt finish leads to considerable surface damage (shiny, spotted areas).

Always have paintwork repairs performed at a qualified specialist workshop, e.g. a Mercedes-Benz Service Centre.

- !** Do not use wash programs with a hot wax treatment under any circumstances.

Observe these notes if your vehicle has a clear matt finish. This will help you to avoid damage to the paintwork due to incorrect treatment.

These notes also apply to light-alloy wheels with a clear matt finish.

- i** The vehicle should preferably be washed by hand using a soft sponge, car shampoo and plenty of water.
- i** Use only insect remover and car shampoo from the range of recommended and approved Mercedes-Benz care products.

Cleaning vehicle parts

Cleaning the wheels

- !** Do not use acidic wheel cleaning products to remove brake dust. This could damage wheel bolts and brake components.
- !** Do not park up the vehicle for an extended period straight after cleaning it, particularly after having cleaned the wheels with wheel cleaner. Wheel cleaners could cause increased corrosion of the brake discs and brake pads/linings. For this reason, you should drive for a few minutes after cleaning. Braking heats the brake discs and the brake pads/linings, thus drying them. The vehicle can then be parked up.

Cleaning the windows

! WARNING

Switch off the windscreen wipers and remove the key from the ignition lock before cleaning the windscreen or the wiper blades. On vehicles with KEYLESS-GO, press the Start/Stop button repeatedly until all indicator lamps in the instrument cluster have gone off. The windscreen wipers could otherwise move and injure you.

- !** Do not use dry cloths, abrasive products, solvents or cleaning agents containing solvents to clean the inside of the windows. Do not touch the insides of the windows with hard objects, e.g. an ice scraper or ring. There is otherwise a risk of damaging the windows.
- !** Clean the water drainage channels of the windscreen and the rear window at regular

intervals. Deposits such as leaves, petals and pollen may under certain circumstances prevent water from draining away. This can lead to corrosion damage and damage to electronic components.

- ▶ Clean the inside and outside of the windows with a damp cloth and a cleaning agent that is recommended and approved by Mercedes-Benz.

Cleaning the wiper blades

! WARNING

Switch off the windscreen wipers and remove the key from the ignition lock before cleaning the windscreen or the wiper blades. On vehicles with KEYLESS-GO, press the Start/Stop button repeatedly until all indicator lamps in the instrument cluster have gone off. The windscreen wipers could otherwise move and injure you.

- !** Do not pull on the wiper blade. Otherwise, the wiper blade could be damaged.
- !** Do not clean wiper blades too often and do not rub them too hard. Otherwise, the graphite coating could be damaged. This could cause wiper noise.
- !** Hold the wiper arm securely when folding back. The windscreen could be damaged if the wiper arm hits against it suddenly.
- ▶ Fold the wiper arms away from the windscreen.
- ▶ Clean the wiper blades carefully using a damp cloth.
- ▶ Fold the windscreen wipers back again before switching on the ignition.

Cleaning the exterior lighting

- !** Only use cleaning agents or cleaning cloths that are suitable for plastic lenses. Unsuitable cleaning agents or cleaning cloths could scratch or damage the plastic lenses of the exterior lighting.

- ▶ Clean the plastic lenses of the exterior lighting using a wet sponge and a mild cleaning agent, e.g. Mercedes-Benz car shampoo or cleaning cloths.

Mirror turn signal

- ▶ **!** Only use cleaning agents or cleaning cloths that are suitable for plastic lenses. Unsuitable cleaning agents or cleaning cloths could scratch or damage the plastic lenses of the mirror turn signals.
- ▶ Clean the plastic lenses of the mirror turn signals in the exterior mirror housing using a wet sponge and mild cleaning agent, e.g. Mercedes-Benz car shampoo or cleaning cloths.

Cleaning the sensors

- ▶ **!** If you clean the sensors with a high-pressure cleaner, make sure that you keep a distance of at least 30 cm between the vehicle and the high-pressure cleaner nozzle. Information about the correct distance is available from the equipment manufacturer.

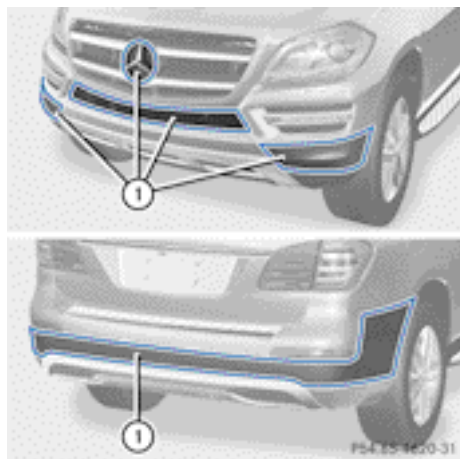

- ▶ Clean sensors (1) of the driving systems with water, car shampoo and a soft cloth.

Cleaning the reversing camera

- ▶ **!** Do not clean the camera lens and the area around the reversing camera with a high-pressure cleaner.

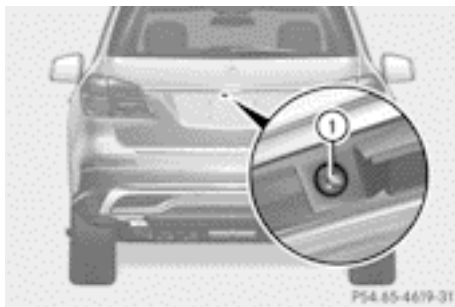



- ▶ Use clear water and a soft cloth to clean camera lens (1).

Cleaning the 360° camera

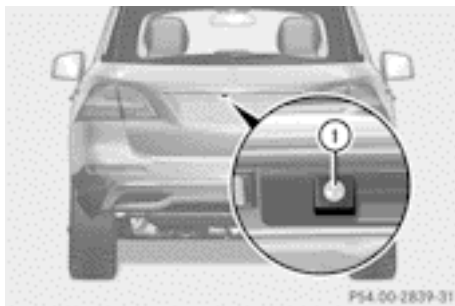
- ▶ **!** Do not clean the camera lens and the area around the 360° camera with a high-pressure cleaner.



- ▶ Make sure that the vehicle is stationary and that the key is in position 2 in the ignition lock.
- ▶ **To open the cover of the 360° camera:** with COMAND Online activated, press the **sys** button.
- ▶ Select **System** by turning **⏪** the COMAND controller and press **⏩** to confirm.
- ▶ Select **360° camera** and press **⏩** to confirm.

- ▶ Select **Open camera cover** and press  to confirm.
The cover of the 360° camera opens.
 - ▶ **To clean the 360° camera:** clean camera lens  with clean water and a soft cloth.
- i** If you are travelling faster than 30 km/h or if the key is in position **0** or **1** in the ignition lock, the cover of the 360° camera closes automatically.

Cleaning the exhaust pipe

- !** Do not clean the exhaust pipe with acidic cleaning agents, such as sanitary or wheel cleaners.

Impurities combined with the effects of road grit and corrosive environmental factors may cause flash rust to form on the surface. You can restore the original shine of the exhaust pipe by cleaning it regularly, especially in winter and after washing.

- ▶ Clean the exhaust pipe with a chrome care product tested and approved by Mercedes-Benz.

Cleaning the trailer tow hitch

Environmental note

Dispose of oily and greasy cloths in an environmentally-responsible manner.

- !** Do not clean the ball coupling with a high-pressure cleaner. Do not use solvents.
- !** Observe the note on care provided by the trailer manufacturer.

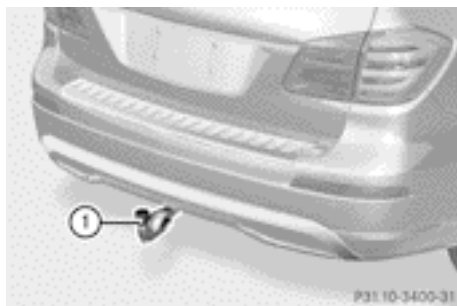

The ball coupling must be cleaned if it becomes dirty or corroded.

- ▶ Remove rust on the ball of the ball coupling, e.g. with a wire brush.
- ▶ Remove dirt with a clean, lint-free cloth or a brush.
- ▶ After cleaning, lightly oil or grease ball coupling .
- ▶ Check that the vehicle's trailer tow hitch is working properly.

- i** You can also have the maintenance work on the ball coupling and the trailer tow hitch carried out by a qualified specialist workshop.

Interior care

Cleaning the display

- !** For cleaning, do not use any of the following:

- alcohol-based thinner or petrol
- abrasive cleaning agents
- commercially-available household cleaning agents

These may damage the display surface. Do not put pressure on the display surface when cleaning. This could lead to irreparable damage to the display.

- ▶ Before cleaning the display, make sure that it is switched off and has cooled down.
- ▶ Clean the display surface using a commercially available microfibre cloth and TFT/LCD display cleaner.
- ▶ Dry the display surface using a dry microfibre cloth.

Cleaning Night View Assist Plus

- !** Never clean the camera lens. When cleaning the field of vision of the driving systems, make sure that you do not spray glass cleaner on the camera lens. If the camera

lens is dirty, visit a qualified specialist workshop.

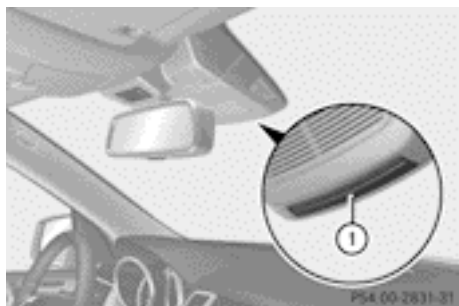

- ▶ Fold down the camera cover by recess ①.

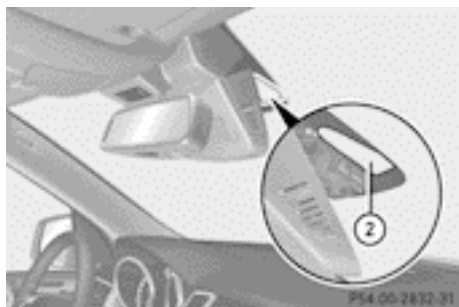

- ▶ Use a soft cloth to clean the windscreen in front of camera ②.

Cleaning the plastic trim

WARNING

When cleaning the steering wheel boss and dashboard, do not use cockpit sprays or cleaning agents containing solvents. Cleaning agents containing solvents cause the surface to become porous, and as a result plastic parts may break away and be thrown around the interior when an airbag is deployed, which may result in severe injuries.

- ❗ Do not affix the following to plastic surfaces:

- stickers
- films
- scented oil bottles or similar items

You could otherwise damage the plastic.

- ❗ Do not allow cosmetics, insect repellent or sunscreen to come in contact with the plastic trim. This maintains the high-quality look of the surfaces.

- ▶ Wipe the plastic trim with a damp, lint-free cloth, e.g. a microfibre cloth.

- ▶ **Heavy soiling:** use car care and cleaning products recommended and approved by Mercedes-Benz.

The surface may change colour temporarily. Wait until the surface is dry again.

Cleaning the steering wheel and gear or selector lever

- ▶ Thoroughly wipe with a damp cloth or use leather care agents that have been recommended and approved by Mercedes-Benz.

Cleaning wooden trim and trim elements

- ❗ Do not use solvent-based cleaning agents such as tar remover, wheel cleaners, polishes or waxes. There is otherwise a risk of damaging the surface.

- ▶ Wipe the wooden trim and trim elements with a damp, lint-free cloth, e.g. a microfibre cloth.

- ▶ **Heavy soiling:** use car care and cleaning products recommended and approved by Mercedes-Benz.

Cleaning the seat covers

- ❗ Observe the following when cleaning:

- clean genuine leather covers carefully with a damp cloth and then wipe the covers down with a dry cloth. Make sure that the leather does not become soaked. It may otherwise become rough and cracked. Only use leather care agents that have been tested and approved by

Mercedes-Benz. You can obtain these from a qualified specialist workshop.

- clean artificial leather covers with a cloth moistened with a solution containing 1 % detergent (e.g. washing-up liquid).
- clean cloth covers with a microfibre cloth moistened with a solution containing 1 % detergent (e.g. washing-up liquid). Rub carefully, and always wipe entire seat sections to avoid leaving visible lines. Leave the seat to dry afterwards. Cleaning results depend on the type of dirt and how long it has been there.
- clean DINAMICA covers with a damp cloth. Make sure that you wipe entire seat sections to avoid leaving visible lines.

! Do not use microfibre cloths to clean genuine leather, artificial leather or DINAMICA covers. If used often, these can damage the cover.

i Note that regular care is essential to make sure that the appearance and comfort of the covers are retained over time.

Cleaning the seat belts

! Do not clean the seat belts using chemical cleaning agents. Do not dry the seatbelts at temperatures above 80 °C or by exposing them to direct sunlight.

- ▶ Use clean, lukewarm water and soap solution.

Cleaning the roof lining and carpets

- ▶ **Roof lining:** if it is very dirty, use a soft brush or dry shampoo.
- ▶ **Carpets:** use the carpet and textile cleaning agents recommended and approved by Mercedes-Benz.

Useful information	376
Where will I find...?	376
Flat tyre	378
Battery (vehicle)	382
Jump-starting	386
Towing and tow-starting	388
Electrical fuses	391

Useful information

- i** This Owner's Manual describes all models, series and optional equipment for your vehicle that were available at the time of going to press. National variations are possible. Note that your vehicle may not be equipped with all of the functions described. This is also the case for systems and functions relevant to safety.
- i** Read the information on qualified specialist workshops: (▷ page 25).

Where will I find...?

Warning triangle

Removing the warning triangle

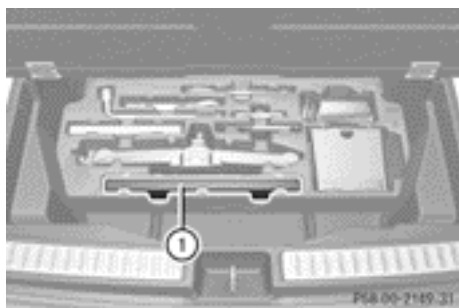

Storage location of the warning triangle (example: vehicle with TIREFIT kit)

Warning triangle ① is located in the stowage well under the luggage compartment floor.

- ▶ Open the tailgate.
- ▶ Lift the luggage compartment floor up (▷ page 344).
- i** Depending on the vehicle's equipment, warning triangle ① may also be located in other places under the luggage compartment floor.
- ▶ Remove warning triangle ①.

Setting up the warning triangle

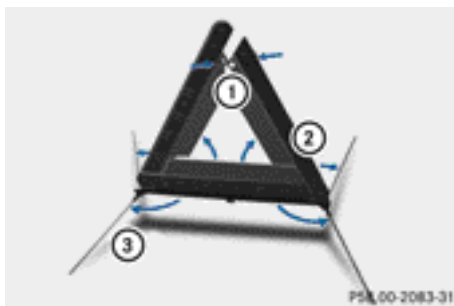

- ① Press-stud
- ② Reflectors
- ③ Feet

- ▶ Fold feet ③ down and out to the side.
- ▶ Pull side reflectors ② upwards to form a triangle and lock them at the top using upper press-stud ①.

First-aid kit

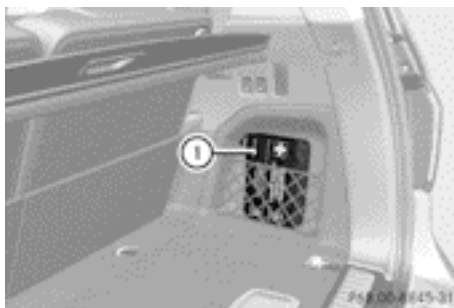

- ▶ Open the tailgate.
- ▶ Remove first-aid kit ① from the luggage net.
- i** Check the expiry date on the first-aid kit at least once a year. Replace the contents if necessary, and replace any missing items.

Fire extinguisher

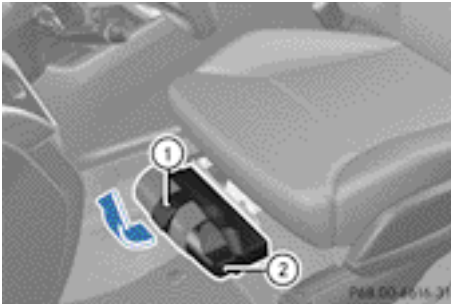

- ▶ Pull tab ① upwards.
- ▶ Remove fire extinguisher ②.

i Have fire extinguisher ② refilled after each use and checked every one to two years. It may otherwise fail in an emergency. Observe the legal requirements for each individual country.

Vehicle tool kit

General notes

The vehicle tool kit can be found in the stowage well under the luggage compartment floor.

i Apart from certain country-specific variations, vehicles are not equipped with a tyre-change tool kit. Some tools for changing a wheel are specific to the vehicle. For more information on which tools are required to perform a wheel change on your vehicle, consult a qualified specialist workshop. Necessary wheel-changing tools can include, for example:

- jack
- wheel chock
- wheel wrench
- ratchet ring spanner
- centring pin

Vehicles with a TIREFIT kit

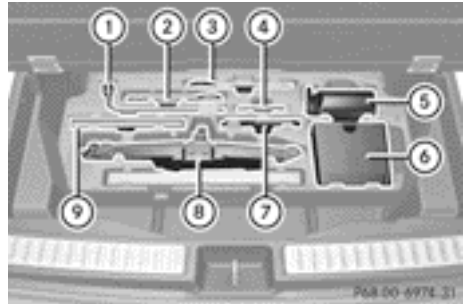

- ① Wheel wrench
- ② Towing eye
- ③ Ratchet ring spanner
- ④ Centring pin
- ⑤ Tyre sealant filler bottle
- ⑥ Tyre inflation compressor
- ⑦ Folding wheel chock
- ⑧ Jack
- ⑨ Wheel bolts

- ▶ Lift the luggage compartment floor up (▷ page 344).

Vehicles with a "Minispare" emergency spare wheel

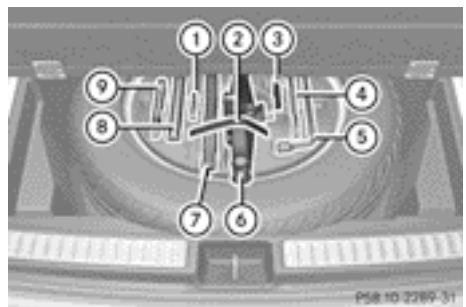

- ① Centring pin
- ② Velcro fastener
- ③ Folding wheel chock
- ④ Ratchet ring spanner
- ⑤ Wheel wrench
- ⑥ Jack

- ⑦ Warning triangle
- ⑧ Wheel bolts
- ⑨ Towing eye
- ▶ Lift the luggage compartment floor up (▷ page 344).

Flat tyre

Preparing the vehicle

Your vehicle may be equipped with:

- MOExtended tyres (tyres with run-flat characteristics) (▷ page 378)
- a TIREFIT kit (▷ page 379)
- an emergency spare wheel (only for certain countries) (▷ page 414)

Information on changing/fitting a wheel (▷ page 404).

Vehicle preparation is not necessary on vehicles with MOExtended tyres.

- ▶ Stop the vehicle as far away as possible from traffic, on solid, non-slippery and level ground.
- ▶ Switch on the hazard warning lamps.
- ▶ Engage the electric parking brake manually.
- ▶ Bring the front wheels into the straight-ahead position.
- ▶ Move the DIRECT SELECT lever to **P**.
- ▶ **Vehicles with the ON&OFFROAD package:** make sure that highway level is selected (▷ page 207).
- ▶ Switch off the engine.
- ▶ **Vehicles without KEYLESS-GO:** remove the key from the ignition lock.
- ▶ **Vehicles with KEYLESS-GO:** open the driver's door.
The on-board electronics have status **0**, which is the same as the key having been removed.
- ▶ **Vehicles with KEYLESS-GO:** remove the Start/Stop button from the ignition lock (▷ page 159).

- ▶ All occupants must leave the vehicle. Make sure that they are not endangered as they do so.
- ▶ Make sure that no one is near the danger area while a wheel is being changed. Anyone who is not directly assisting in the wheel change should, for example, stand behind the barrier.
- ▶ Get out of the vehicle. Pay attention to traffic conditions when doing so.
- ▶ Close the driver's door.
- ▶ Place the warning triangle a suitable distance away (▷ page 376). Observe legal requirements.
- ▶ Unload heavy luggage.

- i** Only operate the tyre inflation compressor using a 12 V socket, even if the ignition is turned off (▷ page 350).

An emergency cut-off ensures that the on-board voltage does not drop too low. If the on-board voltage is too low, the power to the sockets is automatically cut. This ensures that there is sufficient power to start the engine.

MOExtended tyres (tyres with run-flat characteristics)

WARNING

When driving in emergency mode, the driving characteristics deteriorate, e.g. when cornering, accelerating quickly and when braking. There is a risk of accident.

Do not exceed the stated maximum speed. Avoid abrupt steering and driving manoeuvres, and driving over obstacles (kerbs, pot-holes, off-road). This applies in particular to a laden vehicle.

Stop driving in emergency mode if:

- you hear banging noises.
- the vehicle starts to shake.
- you see smoke and smell rubber.

- ESP® is intervening constantly.
- there are tears in the sidewalls of the tyre.

After driving in emergency mode, have the wheel rims checked at a qualified specialist workshop with regard to their further use. The faulty tyre must be replaced.

With MOExtended tyres (tyres with run-flat characteristics), you can continue to drive your vehicle even if there is a total loss of pressure in one or more tyres.

MOExtended tyres may only be used in conjunction with an active tyre pressure loss warning system or with an active tyre pressure monitor.

The maximum driving distance is approximately 80 km when the vehicle is partially laden, and approximately 30 km when the vehicle is fully laden.

In addition to the vehicle load, the driving distance possible depends upon:

- speed
- road condition
- outside temperature

The driving distance possible in run-flat mode may be reduced by extreme driving conditions/manoeuvres, or it can be increased through a moderate style of driving.

The maximum permissible distance which can be driven in run-flat mode is counted from the moment the tyre pressure loss warning appears in the multifunction display.

You must not exceed a maximum speed of 80 km/h.

- i** When replacing one or all tyres, make sure that you only use tyres marked "MOExtended". Make sure that you only use the size of tyre specified for the vehicle.
- i** Vehicles with MOExtended tyres are not equipped with a TIREFIT kit at the factory. It is therefore recommended that you additionally equip your vehicle with a TIREFIT kit if you fit tyres that do not feature run-flat characteristics, e.g. winter tyres. A TIREFIT

kit can be obtained from a qualified specialist workshop.

TIREFIT kit

Using the TIREFIT kit

TIREFIT is a tyre sealant.

You can use TIREFIT to seal punctures of up to 4 mm, particularly those in the tyre tread. You can use TIREFIT at outside temperatures down to -20 °C.

WARNING

In the following situations, the tyre sealant is unable to provide sufficient breakdown assistance, as it is unable to seal the tyre properly:

- there are cuts or punctures in the tyre larger than those mentioned above.
- the wheel rim is damaged.
- you have driven at very low tyre pressures or on a flat tyre.

There is a risk of accident.

Do not drive any further. Contact a qualified specialist workshop.

WARNING

The tyre sealant is harmful and causes irritation. It must not come into contact with your skin, eyes or clothing or be swallowed. Do not inhale TIREFIT fumes. Keep tyre sealant away from children. There is a risk of injury.

If you come into contact with the tyre sealant, observe the following:

- Rinse off the tyre sealant from your skin immediately with water.
- If the tyre sealant comes into contact with your eyes, immediately rinse them thoroughly with clean water.
- If tyre sealant is swallowed, immediately rinse your mouth out thoroughly and drink plenty of water. Do not induce vomiting, and seek medical attention immediately.

- Immediately change out of clothing which has come into contact with tyre sealant.
- If an allergic reaction occurs, seek medical attention immediately.

! Do not operate the tyre inflation compressor for longer than eight minutes at a time without a break. It may otherwise overheat.

The tyre inflation compressor can be operated again once it has cooled down.

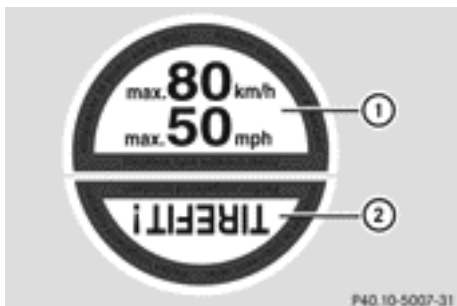

TIREFIT sticker, 2-part

- ▶ Do not remove any foreign objects which have penetrated the tyre, e.g. screws or nails.
- ▶ Remove the tyre sealant bottle, the accompanying TIREFIT sticker and the tyre inflation compressor from the stowage well underneath the luggage compartment floor (▷ page 377).
- ▶ Affix part ① of the TIREFIT sticker within the driver's field of vision.
- ▶ Affix part ② of the TIREFIT sticker near the valve on the wheel with the defective tyre.

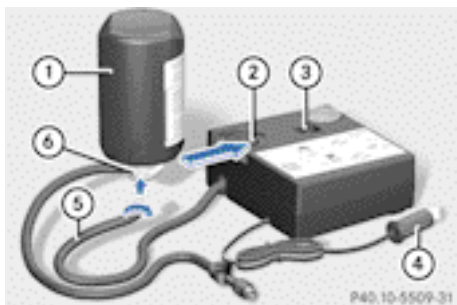

- ▶ Pull plug ④ with the cable and hose ⑤ out of the housing.
- ▶ Screw hose ⑤ onto flange ⑥ of tyre sealant bottle ①.
- ▶ Place tyre sealant bottle ① head downwards into recess ② of the tyre inflation compressor.

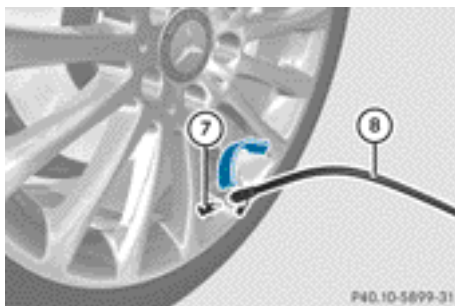

- ▶ Remove the cap from valve ⑦ on the faulty tyre.
- ▶ Screw filler hose ⑧ onto valve ⑦.
- ▶ Insert connector ④ into a 12 V socket in your vehicle.
Observe the notes on sockets (▷ page 350).
- ▶ Turn the key to position 1 in the ignition lock (▷ page 159).
- ▶ Press on/off switch ③ on the tyre inflation compressor to I.
The tyre inflation compressor is switched on. The tyre is inflated.

i First, tyre sealant is pumped into the tyre. The pressure can briefly rise to approximately 500 kPa (5 bar/73 psi).

Do not switch off the tyre inflation compressor during this phase.

- ▶ Let the tyre inflation compressor run for five minutes. The tyre should then have attained a pressure of at least 180 kPa (1.8 bar/26 psi).

If a tyre pressure of 180 kPa (1.8 bar/26 psi) has been attained after five minutes: (▷ page 381).

If a tyre pressure of 180 kPa (1.8 bar / 26 psi) has not been attained after five minutes: (▷ page 381).

- i** If the tyre sealant leaks out, allow it to dry. It can then be removed like a layer of film. If you get tyre sealant on your clothing, have it cleaned as soon as possible with perchloroethylene.

Tyre pressure not reached

If a pressure of 180 kPa (1.8 bar/26 psi) has not been achieved after five minutes:

- ▶ Switch off the tyre inflation compressor.
- ▶ Unscrew the filler hose from the valve of the faulty tyre.
- ▶ Very slowly drive forwards or reverse approximately 10 m.
- ▶ Pump up the tyre again.

After a maximum of five minutes the tyre pressure must be at least 180 kPa (1.8 bar / 26 psi).

WARNING

If the required tyre pressure is not reached after the specified time, the tyre is too badly damaged. The tyre sealant cannot repair the tyre in this instance. Damaged tyres and a tyre pressure that is too low can significantly impair the vehicle's braking and driving characteristics. There is a risk of accident.

Do not continue driving. Contact a qualified specialist workshop.

Tyre pressure reached

WARNING

A tyre temporarily sealed with tyre sealant impairs the driving characteristics and is not suitable for higher speeds. There is a risk of accident.

You should therefore adapt your driving style accordingly and drive carefully. Do not exceed the specified maximum speed with a tyre that has been repaired using tyre sealant.

- !** After use, excess tyre sealant may run out of the filler hose. This could cause stains.

Therefore, place the filler hose in the plastic bag which contained the TIREFIT kit.

Environmental note

Have the used tyre sealant bottle disposed of professionally, e.g. at a qualified specialist workshop.

If a tyre pressure of 180 kPa (1.8 bar/26 psi) has been attained after five minutes:

- ▶ Switch off the tyre inflation compressor.
- ▶ Unscrew the filler hose from the valve of the faulty tyre.
- ▶ Stow the tyre sealant bottle, the tyre inflation compressor and the warning triangle.
- ▶ **Pull away immediately.**

The maximum speed for a tyre sealed with tyre sealant is 80 km/h. The upper part of the TIREFIT sticker must be affixed to the instrument cluster in the driver's field of vision.

- ▶ Stop after driving for approximately ten minutes and check the tyre pressure with the tyre inflation compressor. The tyre pressure must now be at least 130 kPa (1.3 bar / 19 psi).

WARNING

If the required tyre pressure is not reached after driving for a short period, the tyre is too badly damaged. The tyre sealant cannot repair the tyre in this instance. Damaged tyres and a tyre pressure that is too low can significantly impair the vehicle's braking and driving characteristics. There is a risk of accident.

Do not continue driving. Contact a qualified specialist workshop.

- ▶ Correct the tyre pressure if it is still at least 130 kPa (1.3 bar / 19 psi) (see the fuel filler flap for values).
- ▶ **To increase the tyre pressure:** switch on the tyre inflation compressor.

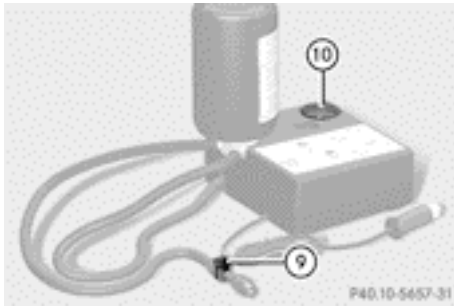

- ⑨ Pressure release button
- ⑩ Pressure gauge

- ▶ **To reduce the tyre pressure:** press pressure release button ⑨ on the filler hose.
- ▶ Stow the tyre sealant bottle, the tyre inflation compressor and the warning triangle.
- ▶ Drive to the nearest qualified specialist workshop and have the tyre changed there.
- ▶ Have the tyre sealant bottle replaced as soon as possible at a qualified specialist workshop.
- ▶ Have the tyre sealant bottle replaced every four years at a qualified specialist workshop.

i In your vehicle, you will find a sticker with the Mercedes-Benz Service24h telephone number, e.g. on the B-pillar on the driver's side.

Battery (vehicle)

Important safety notes

Work on the battery, e.g. removing or installing, requires specialist knowledge and the use of special tools. Therefore, always have work on the battery carried out at a qualified specialist workshop.

⚠ WARNING

Work carried out incorrectly on the battery can, for example, lead to a short circuit and damage your vehicle's electronic system. This can disrupt driving safety systems such as

ABS (anti-lock braking system) or ESP® (Electronic Stability Program).

- If ABS malfunctions, the wheels can lock during braking. This limits the steerability of the vehicle when braking and the braking distance may increase. There is a risk of accident.
- If ESP® malfunctions, the vehicle will not be stabilised if it starts to skid or a wheel starts to spin. There is a risk of accident.

You should therefore have all work involving the battery carried out at a qualified specialist workshop.

⚠ WARNING

Electrostatic build-up can lead to the creation of sparks, which could ignite the highly explosive gases of a battery. There is a risk of an explosion.

Before handling the battery, touch the vehicle body to remove any existing electrostatic build-up.

The highly flammable gas mixture forms when charging the battery as well as when jump-starting.

Always make sure that neither you nor the battery is electrostatically charged. There is a build-up of electrostatic charge, e.g.:

- by wearing clothing made from synthetic fibres
- due to friction between clothing and seats
- if you push or pull the battery across the carpet or other synthetic materials
- if you wipe the battery with a cloth.

⚠ WARNING

During the charging process, a battery produces hydrogen gas. If a short circuit occurs or sparks are created, the hydrogen gas can ignite. There is a risk of an explosion.

- Make sure that the positive terminal of a connected battery does not come into contact with vehicle parts.
- Never place metal objects or tools on a battery.
- It is important that you observe the described order of the battery terminals when connecting and disconnecting a battery.
- When jump-starting, make sure that the battery poles with identical polarity are connected.
- It is particularly important to observe the described order when connecting and disconnecting the jump leads.
- Never connect or disconnect the battery terminals while the engine is running.

WARNING

Battery acid is caustic. There is a risk of injury. Avoid contact with the skin, eyes or clothing. Do not inhale any battery gases. Do not lean over the battery. Keep children away from batteries. Wash battery acid immediately with water and seek medical attention.

Environmental note



Batteries contain pollutants. It is illegal to dispose of them with the household rubbish. They must be collected separately and disposed of in an environmentally responsible recycling system.



Dispose of batteries in an environmentally responsible manner. Take discharged batteries to a qualified specialist workshop or to a collection point for used batteries.

- ! Have the battery checked regularly at a qualified specialist workshop. Observe the service intervals in the Service Booklet or contact a qualified specialist workshop for more information.

- ! You should have all work involving the battery carried out at a qualified specialist workshop. In the exceptional case that it is necessary for you to disconnect the battery yourself, make sure that:

- you switch off the engine and remove the key. On vehicles with KEYLESS-GO, ensure that the ignition is switched off. Check that all the indicator lamps in the instrument cluster are off. Otherwise, electronic components, such as the alternator, may be damaged.
- you first remove the negative terminal clamp and then the positive terminal clamp. Never swap the terminal clamps. Otherwise, the vehicle's electronic system may be damaged.
- the transmission is locked in position **P** after disconnecting the battery. The vehicle is secured against rolling away. You can then no longer move the vehicle.

The battery and the cover of the positive terminal clamp must be fitted securely during operation.

Comply with safety precautions and take protective measures when handling batteries.



WARNING



Fire, naked flames and smoking are prohibited when handling the battery. Avoid creating sparks.



Battery acid is caustic. Avoid contact with the skin, eyes or clothing. Wear suitable protective clothing, in particular gloves, an apron and a face mask.

Immediately rinse acid splashes off with clean water. Consult a doctor if necessary.



Wear eye protection.



Keep children away.



Observe this Owner's Manual.

For safety reasons, Mercedes-Benz recommends that you only use batteries which have been tested and approved for your vehicle by Mercedes-Benz. These batteries provide increased impact protection to prevent vehicle occupants from suffering acid burns should the battery be damaged in the event of an accident.

In order for the battery to achieve the maximum possible service life, it must always be sufficiently charged.

The vehicle battery, like other batteries, can discharge over time if you do not use the vehicle. In such cases, have the battery disconnected at a qualified specialist workshop. You can also charge the battery with a charger recommended by Mercedes-Benz. For more information, please contact a qualified specialist workshop.

Have the battery charge checked more frequently if you use the vehicle mainly for short trips or if you leave it standing idle for a lengthy period. Consult a qualified specialist workshop if you wish to leave your vehicle parked up for a long period of time.

- i** When you park the vehicle, remove the key if you do not require any electrical consumers. The vehicle will then use very little energy, thus conserving battery power.
- i** If the power supply has been interrupted, e.g. if the battery was discharged, you will have to:
 - set the clock. Information on setting the clock can be found in the separate operating instructions.

On vehicles with COMAND Online and a navigation system, the clock is set automatically.

- reset the function for folding the exterior mirrors in/out automatically, by folding the mirrors out once (▷ page 113).

Charging the battery

WARNING

During charging and jump-starting, explosive gases can escape from the battery. There is a risk of an explosion.

Particularly avoid fire, naked flames, creating sparks and smoking. Ensure there is sufficient ventilation while charging and jump-starting. Do not lean over a battery.

WARNING

Battery acid is caustic. There is a risk of injury. Avoid contact with the skin, eyes or clothing. Do not inhale any battery gases. Do not lean over the battery. Keep children away from batteries. Wash battery acid immediately with water and seek medical attention.

WARNING

A discharged battery can freeze at temperatures below freezing point. When jump-starting the vehicle or charging the battery, gases can escape from the battery. There is a risk of an explosion.

Allow the frozen battery to thaw out before charging it or jump-starting.

- !** Only use battery chargers with a maximum charging voltage of 14.8 V.

- !** Only charge the battery using the jump-start connection point.

Never charge a battery still installed in the vehicle unless a battery charger unit approved by Mercedes-Benz is being used. A battery charger unit specially adapted for Mercedes-Benz vehicles and tested and approved by Mercedes-Benz is available as an

accessory. It permits the charging of the battery in its installed position. Contact a Mercedes-Benz Service Centre for information and availability. Charge the battery in accordance with the separate instructions for the battery charger.

The jump-starting connection point is in the engine compartment (▷ page 386).

Read the battery charger's operating instructions before charging the battery.

- ▶ Open the bonnet (▷ page 360).
- ▶ Connect the battery charger to the positive terminal and earth point in the same order as when connecting the donor battery in the jump-starting procedure (▷ page 386).

Jump-starting

WARNING

Battery acid is caustic. There is a risk of injury.

Avoid contact with the skin, eyes or clothing. Do not inhale any battery gases. Do not lean over the battery. Keep children away from batteries. Wash battery acid immediately with water and seek medical attention.

WARNING

During charging and jump-starting, explosive gases can escape from the battery. There is a risk of an explosion.

Particularly avoid fire, naked flames, creating sparks and smoking. Ensure there is sufficient ventilation while charging and jump-starting. Do not lean over a battery.

WARNING

During the charging process, a battery produces hydrogen gas. If a short circuit occurs or sparks are created, the hydrogen gas can ignite. There is a risk of an explosion.

- Make sure that the positive terminal of a connected battery does not come into contact with vehicle parts.
- Never place metal objects or tools on a battery.
- It is important that you observe the described order of the battery terminals when connecting and disconnecting a battery.
- When jump-starting, make sure that the battery poles with identical polarity are connected.
- It is particularly important to observe the described order when connecting and disconnecting the jump leads.
- Never connect or disconnect the battery terminals while the engine is running.

WARNING

A discharged battery can freeze at temperatures below freezing point. When jump-starting the vehicle or charging the battery, gases can escape from the battery. There is a risk of an explosion. Allow the frozen battery to thaw out before charging it or jump-starting.

WARNING

Non-combusted fuel can collect in the exhaust system and ignite. There is a risk of fire. Avoid repeated and lengthy starting attempts.

! **Vehicles with a petrol engine:** avoid repeated and lengthy starting attempts. Otherwise, the non-combusted fuel may damage the catalytic converter.

Do not use a rapid charging device to start the vehicle. If your vehicle's battery is discharged, the engine can be jump-started from another vehicle or from a second battery using jump leads. Observe the following points:

- the battery is not accessible in all vehicles. If the other vehicle's battery is not accessible, jump-start the vehicle using a second battery or a jump-starting device.
- **vehicles with a petrol engine:** only jump-start the vehicle when the engine and exhaust system are cold.
- do not start the engine if the battery is frozen. Let the battery thaw first.
- jump-starting may only be performed from batteries with a nominal voltage of 12 V.
- only use jump leads that have a sufficient cross-section and insulated terminal clamps.
- if the battery is fully discharged, leave the battery that is being used to jump-start connected for a few minutes before attempting to start. This charges the empty battery a little.
- make sure that the two vehicles do not touch.

Make sure that:

- the jump leads are not damaged.
- non-insulated parts of the terminal clamps do not come into contact with other metal parts while the jump leads are connected to the battery.
- the jump leads cannot come into contact with parts such as the V-belt pulley or the fan. These parts move when the engine is started and while it is running.
- ▶ Secure the vehicle by applying the electric parking brake.
- ▶ Shift the transmission to position **P**.
- ▶ Turn the key to position **0** in the ignition lock and remove it (> page 159). On vehicles with KEYLESS-GO, make sure the ignition is switched off (> page 159). All indicator lamps in the instrument cluster must be off.
- ▶ Switch off all electrical consumers (e.g. radio, blower, etc.).
- ▶ Open the bonnet (> page 360).

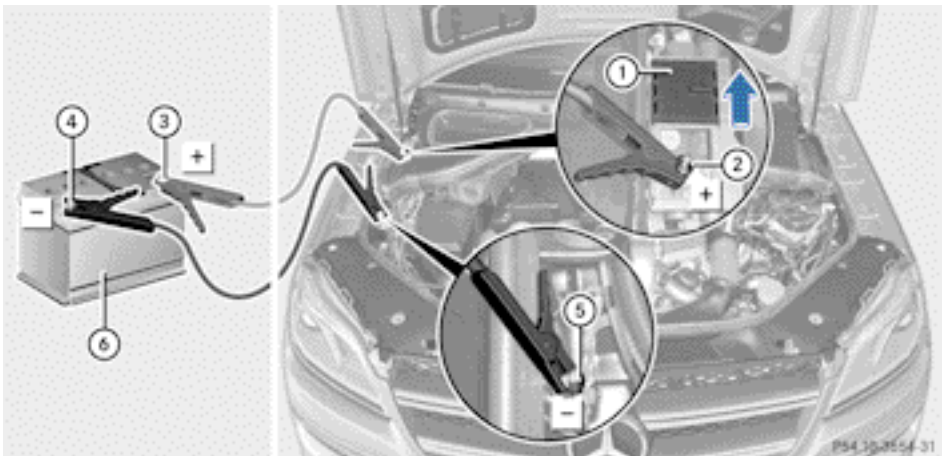

Position number ⑥ identifies the charged battery of the other vehicle or an equivalent jump-starting device.

- ▶ Slide cover ① of positive terminal ② in the direction of the arrow.
 - ▶ Connect positive terminal ② on your vehicle to positive terminal ③ of donor battery ⑥ using the jump lead. Always begin with positive terminal ② on your own vehicle first.
 - ▶ Start the engine of the donor vehicle and run it at idling speed.
 - ▶ Connect negative terminal ④ of donor battery ⑥ to earth point ⑤ of your vehicle using the jump lead, connecting the jump lead to donor battery ⑥ first.
 - ▶ Start the engine.
 - ▶ Before disconnecting the jump leads, let the engines run for several minutes.
 - ▶ First, remove the jump leads from earth point ⑤ and negative terminal ④, then from positive terminal ② and positive terminal ③, each time beginning at the contacts on your own vehicle first.
 - ▶ Close cover ① of positive terminal ② after removing the jump leads.
 - ▶ Have the battery checked at a qualified specialist workshop.
- i** Jump-starting is not considered to be a normal operating condition.
- i** Jump-starting cables and further information regarding jump starting can be obtained at any qualified specialist workshop.

Towing and tow-starting

Important safety notes

WARNING

Safety-relevant functions are restricted or not available if:

- the engine is not running.
- the brake system or the power steering is malfunctioning
- the voltage supply or the vehicle's electrical system is malfunctioning.

If your vehicle is towed, significantly greater force may be required to steer the vehicle or to brake. There is a risk of an accident.

In such circumstances, use a towing bar. Make sure that the steering is moving freely before towing.

WARNING

If the weight of the vehicle to be towed or tow-started is greater than the permissible gross weight of your vehicle:

- the towing eye could detach itself
- the vehicle/trailer combination could overturn.

There is a risk of an accident.

When towing or tow-starting another vehicle, its weight should not be greater than the permissible gross weight of your vehicle.

WARNING

The vehicle is braked when the HOLD function or DISTRONIC PLUS is activated. Therefore, deactivate HOLD and DISTRONIC PLUS if the vehicle is to be towed.

! Make sure that the electric parking brake is released. If the electric parking brake is faulty, visit a qualified specialist workshop.

! Only secure the tow rope or towing bar to the towing eyes. The vehicle may otherwise be damaged.

! Observe the following points when towing with a tow rope:

- secure the tow rope on the same side on both vehicles.
- the tow rope must not be longer than is legally permitted. It should be marked in the middle, e.g. with a white cloth (30 x 30 cm) so that other road users are aware that a vehicle is being towed.
- the tow rope may only be attached to the towing eyes.
- observe the brake lamps of the towing vehicle while driving. Always maintain a distance so that the tow rope does not sag.
- do not use steel cables or chains to tow your vehicle. The vehicle could be damaged.

! Do not use the towing eye for recovery, this could damage the vehicle. If in doubt, recover the vehicle with a crane.

! When towing, pull away slowly and smoothly. If the tractive power is too high, the vehicles could be damaged.

! To tow vehicles with KEYLESS-GO, use the key instead of the Start/Stop button. The automatic transmission may otherwise switch to position **P** when you open the driver's or front-passenger door which could damage the transmission.

! Vehicles with differential locks: make sure the differential locks are in automatic mode. When towing, the differential locks must not be switched on. The transmission may otherwise be damaged.

! You may tow the vehicle for a maximum of 50km. A towing speed of 50 km/h must not be exceeded.

For towing distances over 50 km, the entire vehicle must be lifted up and transported.

! If you tow or tow-start another vehicle, its weight must not exceed the maximum per-

missible gross vehicle weight of your vehicle.

Information on your vehicle's gross vehicle weight rating can be found on the vehicle identification plate (▷ page 422).

Observe the legal requirements for the relevant countries when towing.

It is better to have the vehicle transported than to have it towed.

If the vehicle has suffered transmission damage, have it transported on a transporter or trailer.

The automatic transmission must be in position **N** when the vehicle is being towed.

The battery must be connected and charged. Otherwise, you:

- cannot turn the key in the ignition lock to position **2**
- cannot release the electric parking brake
- cannot shift the automatic transmission to position **N**

i Deactivate the automatic locking feature (▷ page 283). You could otherwise be locked out when pushing or towing the vehicle.

Deactivate tow-away protection (▷ page 71) before the vehicle is towed.

Fitting/removing the towing eye

Fitting the towing eye

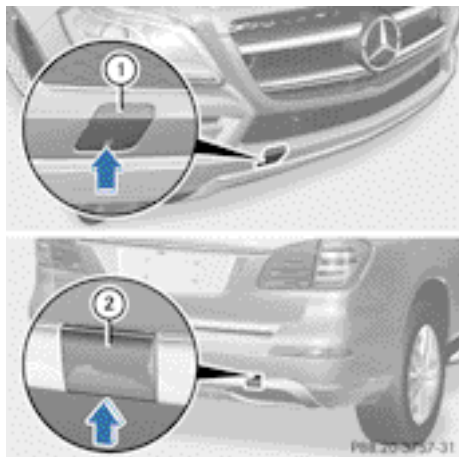

Example: covers for towing eye mountings

- ① Front cover
- ② Back cover

Vehicles with a trailer tow hitch: if you intend to use the vehicle for towing, fold out the ball coupling (▷ page 259) and connect the tow-bar to it.

The brackets for the screw-in towing eyes are located in the bumpers. They are at the front and at the rear, under the covers.

- ▶ Remove the towing eye from the vehicle tool kit (▷ page 377).
- ▶ **To open the cover at the front:** press the mark on cover ① inwards in the direction of the arrow.
- ▶ **To open the cover at the rear:** insert a flat, blunt object into the cutout and lever cover ② out of the bumper.
- ▶ Remove cover ① or ② from the opening.
- ▶ Screw the towing eye in clockwise to the stop and tighten it.

Removing the towing eye

- ▶ Loosen the towing eye and unscrew it.
- ▶ Attach cover ① or ② to the bumper and press until it engages.
- ▶ Place the towing eye in the vehicle tool kit.

Towing the vehicle with both axles on the ground

It is important that you observe the safety instructions when towing away your vehicle (▷ page 388).

The automatic transmission automatically shifts to position **P** when you open the driver's or front-passenger door or when you remove the key from the ignition lock.

In order to ensure that the automatic transmission stays in position **N** when towing the vehicle, you must observe the following points:

- ▶ Make sure that the vehicle is stationary and that the key is in position **0** in the ignition lock.
- ▶ Turn the key to position **2** in the ignition lock.
 - On vehicles with KEYLESS-GO, use the key instead of the Start/Stop button (▷ page 159).
- ▶ Depress and hold the brake pedal.
- ▶ Shift the automatic transmission to position **N**.
- ▶ Release the brake pedal.
- ▶ Release the electric parking brake.
- ▶ Leave the key in position **2** in the ignition lock.
- ▶ Switch on the hazard warning lamps (▷ page 122).
- ▶ **i** In order to signal a change of direction when towing the vehicle with the hazard warning lamps switched on, use the combination switch as usual. In this case, only the turn signals for the desired direction flash. When you reset the combination

switch, the hazard warning lamps start flashing again.

Transporting the vehicle

! Only lash the vehicle down by the wheels or wheel rims, not by parts of the vehicle such as axle or steering components. Otherwise, the vehicle could be damaged.

The towing eyes or trailer tow hitch can be used to pull the vehicle onto a trailer or transporter if you wish to transport it.

- ▶ Turn the key to position **2** in the ignition lock.
- ▶ Shift the automatic transmission to position **N**.

As soon as the vehicle is loaded:

- ▶ Prevent the vehicle from rolling away by applying the electric parking brake.
- ▶ Shift the automatic transmission to position **P**.
- ▶ Turn the key to position **0** in the ignition lock and remove it.
- ▶ Secure the vehicle.

Information for 4MATIC vehicles

! Vehicles with 4MATIC must not be towed with the front or rear axle raised; otherwise, the transmission may be damaged.

If the vehicle has transmission damage or damage to the front or rear axle, have it transported on a transporter or trailer.

In the event of damage to the electrical system

If the battery is defective, the automatic transmission will be locked in position **P**. To shift the automatic transmission to position **N**, you must provide power to the vehicle's electrical system in the same way as when jump-starting (▷ page 386).

Have the vehicle transported on a transporter or trailer.

Recovering a vehicle that has become stuck

! When recovering a trapped vehicle, do not jerk the vehicle or pull it at an angle. If the tractive power is too high, the vehicles could be damaged.

If the drive wheels get trapped on loose or muddy ground, recover the vehicle with the utmost care, especially so if the vehicle is laden.

Never attempt to recover a vehicle with a trailer attached.

Pull out the vehicle backwards, if possible, using the tracks it made when it became stuck.

Tow-starting (emergency engine starting)

! Vehicles with automatic transmission must not be tow-started. Otherwise, you could damage the automatic transmission.

You can find information on "Jump-starting" at (▷ page 386).

Electrical fuses

Important safety notes

WARNING

Only use fuses that have been approved for Mercedes-Benz vehicles and which have the correct fuse rating for the systems concerned. Do not attempt to repair or bridge faulty fuses. Using fuses which have not been approved or attempting to repair or bridge faulty fuses could cause the fuse to be overloaded and result in a fire. Have the cause traced and rectified at a qualified specialist workshop.

! Only use fuses marked with an "S" for the fuse box in the engine compartment and under the rear bench seat. Components or systems could otherwise be damaged.

The fuses in your vehicle serve to close down faulty circuits. If a fuse blows, all the components on the circuit and their functions stop operating.

Blown fuses must be replaced with fuses of the same rating, which you can recognise by the colour and fuse rating. The fuse ratings are listed in the fuse allocation chart.

If the newly inserted fuse also blows, have the cause traced and rectified at a qualified specialist workshop, e.g. a Mercedes-Benz Service Centre.

Before replacing a fuse

- ▶ Secure the vehicle against rolling away (▷ page 181).
- ▶ Switch off all electrical consumers.
- ▶ Turn the key to position **0** in the ignition lock and remove it (▷ page 159). On vehicles with KEYLESS-GO, make sure the ignition is switched off (▷ page 159). All indicator lamps in the instrument cluster must be off.

The fuses are located in various fuse boxes:

- fuse box on the front-passenger side of the dashboard
- fuse box in the engine compartment on the right-hand side of the vehicle, when viewed in the direction of travel
- fuse box under the rear bench seat

The fuse allocation chart is located in the fuse box under the rear bench seat (▷ page 393).

Dashboard fuse box

- ❗ Do not use a pointed object such as a screwdriver to open the cover in the dashboard. You could damage the dashboard or the cover.
- ❗ Make sure that no moisture can enter the fuse box when the cover is open.
- ❗ When closing the cover, make sure that it is lying correctly on the fuse box. Moisture

seeping in or dirt could otherwise impair the operation of the fuses.

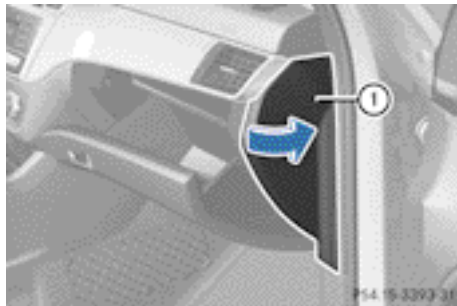

- ▶ **To open:** pull cover ① outwards in the direction of the arrow and remove it.
- ▶ **To close:** clip in cover ① on the front of the dashboard.
- ▶ Fold cover ① inwards until it engages.

Fuse box in the engine compartment

- ❗ Make sure that no moisture can enter the fuse box when the cover is open.
- ❗ When closing the cover, make sure that it is lying correctly on the fuse box. Moisture seeping in or dirt could otherwise impair the operation of the fuses.

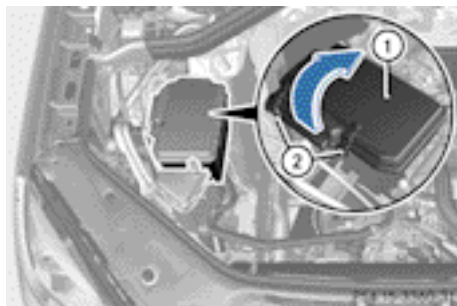

- ▶ Open the bonnet.
- ▶ Remove any existing moisture from the fuse box using a dry cloth.
- ▶ **To open:** open clamps ②.
- ▶ Fold up cover ① in the direction of the arrow and remove it.

- ▶ **To close:** check whether the seal is seated correctly in cover ①.
- ▶ Insert cover ① at the side of the fuse box into the retainers.
- ▶ Fold down cover ① and close clamps ②.
- ▶ Close the bonnet.

Fuse box under the rear bench seat

- ❗ Make sure that no moisture can enter the fuse box when the cover is open.
- ❗ When closing the cover, make sure that it is lying correctly on the fuse box. Moisture seeping in or dirt could otherwise impair the operation of the fuses or the cover could be damaged by the rear bench seat.
- ▶ Fold the left-hand rear bench seat forward (▷ page 341).

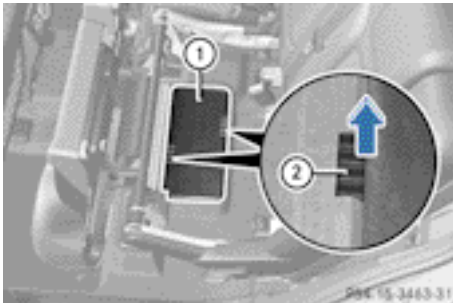

- ▶ **To open:** reach into recesses ② on each side of fuse box cover ①.
- ▶ Fold cover ① up in the direction of the arrow and remove it from the fuse box.
- ❗ The fuse allocation chart is located in a recess at the side of the fuse box.
- ▶ **To close:** place cover ① on the fuse box.
- ▶ Press cover ① down until you feel the clamps engage.
- ▶ Fold back the left-hand rear bench seat (▷ page 341).

Useful information	396
Important safety notes	396
Operation	396
Winter operation	398
Tyre pressure	399
Changing a wheel	404
Wheel and tyre combinations	409
Emergency spare wheel	414

Useful information

- i** This Owner's Manual describes all models, series and optional equipment for your vehicle that were available at the time of going to press. National variations are possible. Note that your vehicle may not be equipped with all of the functions described. This is also the case for systems and functions relevant to safety.
- i** Read the information on qualified specialist workshops: (▷ page 25).

Important safety notes

WARNING

If wheels and tyres of the wrong size are used, the wheel brakes or suspension components may be damaged. There is a risk of accident. Always replace wheels and tyres with those that fulfil the specifications of the original part (designation, manufacturer, model).

WARNING

A flat tyre severely impairs the driving, steering and braking characteristics of the vehicle. There is a risk of accident.

Tyres without run-flat characteristics:

- do not drive with a flat tyre.
- immediately replace the flat tyre with your emergency spare wheel or spare wheel, or consult a qualified specialist workshop.

Tyres with run-flat characteristics:

- pay attention to the information and warning notices on MOExtended tyres (tyres with run-flat characteristics).

Accessories that are not approved for your vehicle by Mercedes-Benz or are not being used correctly can impair the operating safety.

Before purchasing and using non-approved accessories, visit a qualified specialist workshop and enquire about:

- suitability
- legal stipulations
- factory recommendations

Information on the dimensions and types of wheels and tyres for your vehicle can be found in the "Wheel/tyre combinations" section (▷ page 409).

Information on air pressure for the tyres on your vehicle can be found:

- on the tyre pressure label on the fuel filler flap (▷ page 175)
- in the "Tyre pressure" section
- under "Tyre pressure" (▷ page 399)

Modification work on the brake system and wheels is not permitted. The use of wheel spacers or brake dust shields is not permitted. This invalidates the general operating permit for the vehicle.

- i** Further information on wheels and tyres can be obtained at any qualified specialist workshop.

Operation

Information on driving

Check the tyre pressures when the vehicle is heavily laden and, if necessary, adjust.

While driving, pay attention to vibrations, noises and unusual handling characteristics, e.g. pulling to one side. This may indicate that the wheels or tyres are damaged. If you suspect that a tyre is defective, reduce your speed immediately. Stop the vehicle as soon as possible to check the wheels and tyres for damage. Hidden tyre damage could also be causing the unusual handling characteristics. If you find no signs of damage, have the tyres and wheels checked at a qualified specialist workshop.

When parking your vehicle, make sure that the tyres do not get deformed by the kerb or

other obstacles. If it is necessary to drive over kerbs, speed humps or similar elevations, try to do so slowly and at an obtuse angle. Otherwise, the tyres, particularly the sidewalls, may be damaged.

Regular checking of wheels and tyres

WARNING

Damaged tyres can cause tyre inflation pressure loss. As a result, you could lose control of your vehicle. There is a risk of accident.

Check the tyres regularly for signs of damage and replace any damaged tyres immediately.

Regularly check the wheels and tyres of your vehicle for damage at least once a month, as well as after driving off-road or on rough roads. Damaged wheels can cause a loss of tyre pressure. Pay particular attention to damage such as:

- cuts in the tyres
- punctures
- tears in the tyres
- bulges on tyres
- deformation or severe corrosion on wheels

Regularly check the tyre tread depth and the condition of the tread across the whole width of the tyre (> page 397). If necessary, turn the front wheels to full lock in order to inspect the inner side of the tyre surface.

All wheels must have a valve cap to protect the valve against dirt and moisture. Do not fit anything onto the valve other than the standard valve cap or other valve caps approved by Mercedes-Benz for your vehicle. Do not fit any other valve caps or systems, e.g. tyre pressure monitoring systems.

Regularly check the pressure of all the tyres, particularly prior to long trips. Adjust the tyre pressure as necessary (> page 399).

Observe the notes on the emergency spare wheel (> page 414).

The service life of tyres depends on various factors, including the following:

- driving style
- tyre pressure
- tyre mileage

Tyre tread

WARNING

Insufficient tyre tread will reduce tyre traction. The tyre is no longer able to dissipate water. This means that on wet road surfaces, the risk of aquaplaning increases, in particular where speed is not adapted to suit the driving conditions. There is a risk of accident.

If the tyre pressure is too high or too low, tyres may exhibit different levels of wear at different locations on the tyre tread. Thus, you should regularly check the tread depth and the condition of the tread across the entire width of all tyres.

Minimum tyre tread depth for:

- summer tyres: 3 mm
- M+S tyres: 4 mm

For safety reasons, replace the tyres before the legally prescribed limit for the minimum tyre tread depth is reached..

Selecting, fitting and replacing tyres

- Only fit tyres and wheels of the same type and make.
- Only fit tyres of the correct size onto the wheels.
- Run in new tyres at moderate speeds for the first 100 km. They only reach their full performance after this distance.
- Do not drive with tyres which have too little tread depth. This otherwise significantly reduces the traction on wet roads (aquaplaning).
- Replace the tyres after six years at the latest, regardless of wear.

Observe the notes on the emergency spare wheel (▷ page 414).

MOExtended tyres (tyres with run-flat characteristics)

With MOExtended tyres (tyres with run-flat characteristics), you can continue to drive your vehicle even if there is a total loss of pressure in one or more tyres.

MOExtended tyres may only be used in conjunction with an active tyre pressure loss warning system or with an active tyre pressure monitor and on wheels specifically tested by Mercedes-Benz.

Notes on driving with MOExtended tyres with a flat tyre (▷ page 378).

- i** Vehicles with MOExtended tyres are not equipped with a TIREFIT kit at the factory. It is therefore recommended that you additionally equip your vehicle with a TIREFIT kit if you fit tyres that do not feature run-flat characteristics, e.g. winter tyres. A TIREFIT kit can be obtained from a qualified specialist workshop.

Winter operation

General notes

Have your vehicle winterproofed at a qualified specialist workshop at the onset of winter.

Observe the notes in the "Changing a wheel" section (▷ page 404).

Driving with summer tyres

At temperatures below +7 °C, summer tyres lose elasticity and therefore traction and braking power. Change the tyres on your vehicle to M+S tyres. Using summer tyres at very cold temperatures could cause tears to form, thereby damaging the tyres permanently. Mercedes-Benz cannot accept responsibility for this type of damage.

M+S tyres

WARNING

M+S tyres with a tyre tread depth of less than 4 mm are not suitable for use in winter as they do not provide sufficient traction. There is a risk of accident.

M+S tyres with a tread depth of less than 4 mm must be replaced.

At temperatures below +7 °C, use winter tyres or all-season tyres. Both types of tyre are identified by the M+S marking.

Only winter tyres bearing the  snowflake symbol in addition to the M+S marking provide the best possible grip in wintry road conditions.

Only these tyres will allow driving safety systems such as ABS and ESP® to function optimally in winter. These tyres have been developed specifically for driving in snow.

Use M+S tyres of the same make and tread on all wheels to maintain safe handling characteristics.

Always observe the maximum permissible speed specified for the M+S tyres you have fitted.

If you fit M+S tyres that have a lower maximum permissible speed than that of the vehicle, affix a corresponding warning label in the driver's field of vision. This can be obtained at a qualified specialist workshop.

Under these circumstances, you should also restrict the maximum speed of the vehicle using permanent SPEEDTRONIC so that it does not exceed the maximum permissible speed for the M+S tyres (▷ page 198).

When you have fitted the M+S tyres:

- ▶ Check the tyre pressures (▷ page 399).
- ▶ Restart the tyre pressure monitor (▷ page 403).
- ▶ Restart the tyre pressure loss warning system (▷ page 401).

For more information on driving with the emergency spare wheel, see (▷ page 414).

Snow chains

WARNING

If you have fitted snow chains to the front wheels, they may scrape against the vehicle body or chassis components. This could cause damage to the vehicle or the tyres. There is a risk of an accident.

To avoid hazardous situations:

- never fit snow chains on the front wheels
- fit snow chains to the rear wheels in pairs.

! You must drive at raised vehicle level if snow chains have been fitted. The vehicle could otherwise be damaged. Observe the information in the "AIRMATIC package" section.

! Do not use the Adaptive Damping System (ADS) sports mode if you have fitted snow chains. The vehicle could otherwise be damaged.

! On some tyre sizes there is not enough space for snow chains. In order to prevent damage to the vehicle or the tyres, observe the "Tyre and wheel combinations" section under "Tyres and wheels".

For safety reasons, Mercedes-Benz recommends that you only use snow chains that have been specially approved for your vehicle by Mercedes-Benz, or that are of a corresponding standard of quality.

If you intend to fit snow chains, please bear the following points in mind:

- only use snow chains when the road surface is completely snow-covered. Remove the snow chains as soon as possible when you come to a road that is not snow-covered.
- do not exceed the maximum permissible speed of 50 km/h.

- local regulations may restrict the use of snow chains. Observe the appropriate regulations if you wish to fit snow chains.
- snow chains cannot be fitted to all wheel-tyre combinations. Permissible wheel-tyre combinations (▷ page 409).

i You may wish to deactivate ESP® when pulling away with snow chains fitted (▷ page 67). This way you can allow the wheels to spin in a controlled manner, achieving an increased driving force (cutting action).

For more information on driving with the emergency spare wheel, see (▷ page 414).

Tyre pressure

Tyre pressure specifications

WARNING

Tyres with too low or too high tyre pressure contain the following hazards:

- they can burst, in particular if the vehicle is heavily laden or when driven at high speeds.
- the tyres can wear excessively and/or unevenly, which can severely impair tyre traction.
- the driving, steering and braking characteristics may be severely impaired.

There is a risk of accident.

Follow recommended tyre inflation pressures and check the pressure of all the tyres including the spare wheel:

- at least every two weeks
- if the load changes
- before beginning a long journey
- for changed operating conditions, e.g. off-road driving

If necessary, correct the tyre pressure.

WARNING

If you fit unsuitable accessories onto tyre valves, the tyre valves may be overloaded and

malfunction, which can cause tyre pressure loss. Due to their design, retrofitted tyre pressure monitors keep the tyre valve open. This can also result in tyre pressure loss. There is a risk of accident.

Only screw standard valve caps or valve caps specifically provided by Mercedes-Benz for your vehicle onto the tyre valve.

WARNING

If the tyre pressure drops repeatedly, the wheel, valve or tyre may be damaged. Tyre pressure that is too low may result in a tyre blow-out. There is a risk of accident.

- Check the tyre for foreign objects.
- Check whether the wheel is losing air or the valve is leaking.

If you are unable to rectify the damage, contact a qualified specialist workshop.

Environmental note

Check the tyre pressure regularly, at least every 14 days.

You will find a table of tyre pressures for various operating conditions on the inside of your vehicle's fuel filler flap.

Operation with the emergency spare wheel (▷ page 414).

Operation with a trailer: the applicable value for the rear tyres is the maximum tyre pressure value stated in the table inside the fuel filler flap.

The table inside the fuel filler flap may state tyre pressures for different load conditions. These are defined in the table as different numbers of passengers and amounts of luggage. The actual number of seats may vary – for more information, please refer to the vehicle's registration documents.

If tyre sizes are not specified, the tyre pressures stated on the tyre pressure information label apply for all tyres approved for this vehicle.

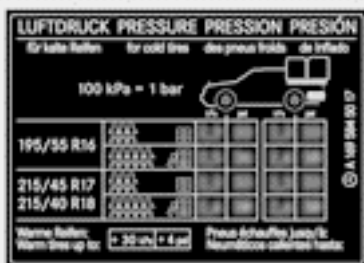

The image shows a tyre pressure information label with the following content:

LUFTDRUCK PRESSURE PRESSION PRESSION
 für kalte Reifen für kalte Reife des pneus froids des pneus
 100 kPa = 1 bar

Reifenart	1 Person	2 Personen	3 Personen	4 Personen
195/55 R16	2.3	2.5	2.7	2.9
215/45 R17	2.3	2.5	2.7	2.9
215/45 R18	2.3	2.5	2.7	2.9

Normale Belastung Norm loading for: 2.25 t / 4.95 t
 Druck Anschlag/tyre lock/tyre
 Mercedes-Benz/mercedes-benz

P40.00-2193-31

If a tyre size precedes a tyre pressure, the following tyre pressure information is only valid for that tyre size.

Use a suitable pressure gauge to check the tyre pressure. The outer appearance of a tyre does not permit any reliable conclusion about the tyre pressure. On vehicles fitted with the electronic tyre pressure monitor, the tyre pressure can be checked using the on-board computer.

If possible, only correct tyre pressures when the tyres are cold.

The tyres are cold:

- if the vehicle has been parked with the tyres out of direct sunlight for at least three hours and
- if the vehicle has not been driven further than 1.6 km

Depending on the ambient temperature, the speed at which you are driving and the load on the tyres, the tyre temperature and thus the tyre pressure change by approximately 10 kPa per 10 °C (0.1 bar/1.5 psi). Take this into account when checking the pressure of warm tyres. Only correct the tyre pressure if it is too low for the current operating conditions.

Driving with tyre pressure that is too high or too low can:

- shorten the service life of the tyres
- cause increased tyre damage
- have a negative effect on handling characteristics and thus the driving safety (e.g. aquaplaning)

i The tyre pressure values given for low loads are minimum values which offer you good ride comfort characteristics.

However, you can also use the values given for higher loads. These are permissible and will not adversely affect the running of the vehicle.

Tyre pressure loss warning system

Important safety notes

While the vehicle is in motion, the tyre pressure loss warning system monitors the set tyre pressure using the rotational speed of the wheels. This enables the system to detect significant pressure loss in a tyre. If the speed of rotation of a wheel changes as a result of a loss of pressure, a corresponding warning message will appear in the multifunction display.

The tyre pressure warning system does not warn you of an incorrectly set tyre pressure. Observe the notes on the recommended tyre pressure (▷ page 399).

The tyre pressure loss warning system does not replace the need to regularly check your vehicle's tyre pressures, since an even loss of pressure on several tyres at the same time cannot be detected by the tyre pressure loss warning system.





The tyre pressure monitor is not able to warn you of a sudden loss of pressure, e.g. if the tyre is penetrated by a foreign object. In the event of a sudden loss of pressure, bring the vehicle to a halt by braking carefully. Avoid abrupt steering manoeuvres.

The function of the tyre pressure loss warning system is limited or delayed if:

- snow chains are fitted to your vehicle's tyres.
- road conditions are wintry.
- you are driving on sand or gravel.
- you adopt a very sporty driving style (cornering at high speeds or driving with high rates of acceleration).
- you are towing a very heavy or large trailer.
- you are driving with a heavy load (in the vehicle or on the roof).

Restarting the tyre pressure loss warning system



Restart the tyre pressure loss warning system if you have:

- changed the tyre pressure
 - changed the wheels or tyres
 - fitted new wheels or tyres
- ▶ Before restarting, make sure that the tyre pressures are set properly on all four tyres for the respective operating conditions. The recommended tyre pressures can be found in the table on the fuel filler flap.
- The tyre pressure loss warning system can only give reliable warnings if you have set the correct tyre pressure. If an incorrect tyre pressure is set, these incorrect values will be monitored.
- ▶ Also observe the notes in the section on tyre pressures (▷ page 399).
- ▶ Make sure that the key is in position **2** (▷ page 159) in the ignition lock.
- ▶ Press the  or  button on the steering wheel to select the **Serv.** menu.
- ▶ Press the  or  button to select **Tyre pressure**.
- ▶ Press the  button.
- The **Run Flat Indicator active Restart with OK** message appears in the multifunction display.

If you wish to confirm the restart:

- ▶ Press the  button.





The **Tyre press. now OK?** message appears in the multifunction display.

- ▶ Press the  or  button to select **Yes**.
- ▶ Press the  button.

The **Run Flat Indicator restarted** message appears in the multifunction display.

After a teach-in period, the tyre pressure loss warning system will monitor the set tyre pressures of all four tyres.

If you wish to cancel the restart:

- ▶ Press the  button.
- or
- ▶ If the **Tyre press. now OK?** message appears, use the  or  button to select **Cancel**.
- ▶ Press the  button.
The tyre pressure values stored at the last restart will continue to be monitored.

Tyre pressure monitor

Important safety notes

It is the driver's responsibility to set the tyre pressure to the recommended cold tyre pressure suitable for the operating situation (▷ page 399). Note that the correct tyre pressure for the current operating situation must first be taught-in to the tyre pressure monitor. If there is a substantial loss of pressure, the warning threshold for the warning message is aligned to the reference values taught-in. Restart the tyre pressure monitor after adjusting to the cold tyre pressure (▷ page 403). The current pressures are saved as new reference values. This will ensure that a warning message will only appear if the tyre pressure drops significantly. The tyre pressure monitor does not warn you of an incorrectly set tyre pressure. Observe the notes on the recommended tyre pressure (▷ page 399).

The tyre pressure monitor is not able to warn you of a sudden loss of pressure, e.g. if the tyre is penetrated by a foreign object. In the event of a sudden loss of pressure, bring the vehicle to a halt by braking carefully. Avoid abrupt steering manoeuvres.

If a tyre pressure monitor system is fitted, the vehicle's wheels have sensors fitted that monitor the tyre pressures in all four tyres.





The tyre pressure monitor warns you if the pressure drops in one or more of the tyres. The tyre pressure monitor only functions if the corresponding sensors are fitted to all wheels.

Information on tyre pressures is displayed in the multifunction display. After a few minutes of driving, the current tyre pressure of each tyre is shown in the multifunction display.

The tyre pressure values indicated by the on-board computer may differ from those measured at a filling station using a pressure gauge. The tyre pressures shown by the on-board computer refer to those measured at sea level. At high altitudes, the tyre pressure values indicated by a pressure gauge are higher than those shown by the on-board computer. In this case, do not reduce the tyre pressures.

The operation of the tyre pressure monitor can be affected by interference from radio transmitting equipment (e.g. radio headphones, two-way radios) that may be being operated in or near the vehicle.

Checking tyre pressure electronically

- ▶ Make sure that the key is in position **2** (▷ page 159) in the ignition lock.
- ▶ Press the  or  button on the steering wheel to select the **Serv.** menu.
- ▶ Press the  or  button to select **Tyre pressure**.
- ▶ Press the  button.
The current tyre pressure for each wheel will be displayed in the multifunction display.

If the vehicle has been parked for longer than 20 minutes, the **Tyre pressures will be displayed after a few minutes of driving** message appears.

After a teach-in period, the tyre pressure monitor automatically recognises new wheels or new sensors. As long as a clear allocation of the tyre pressure values to the individual wheels is not possible, the **Tyre**

pressure monitor active display message is shown instead of the tyre pressure display. The tyre pressures are already being monitored.

Warning messages of the tyre pressure monitor

If the tyre pressure monitor detects a significant pressure loss on one or more tyres, a warning message is shown in the multifunction display. A warning tone also sounds and the tyre pressure warning lamp lights up in the instrument cluster.

Each tyre that is affected by a significant loss of pressure is highlighted in the pressure display.

- ▶ If the **Please correct tyre pressure** message appears in the multifunction display, check the tyre pressure on all four wheels and correct it if necessary.





i If the wheel positions on the vehicle are interchanged, the tyre pressures may be displayed for the wrong positions for a short time. This is rectified after a few minutes of driving, and the tyre pressures are displayed for the correct positions.

Restarting the tyre pressure monitor

When you restart the tyre pressure monitor, all existing warning messages are deleted and the warning lamps go out. The monitor uses the currently set tyre pressures as the reference values for monitoring. In most cases, the tyre pressure monitor will automatically detect the new reference values after you have changed the tyre pressure. However, you can also define reference values manually as described here.

- ▶ Use the table on the inside of the fuel filler flap to ensure that the tyre pressure is set correctly in all four tyres for the current operating conditions.

Also observe the notes in the section on tyre pressures (▷ page 399).

- ▶ Make sure that the key is in position **2** in the ignition lock.
- ▶ Press the  or  button on the steering wheel to select the **Serv.** menu.
- ▶ Press the  or  button to select **Tyre pressure**.
- ▶ Press the  button.

The multifunction display shows the current tyre pressure for the individual tyres or the **Tyre pressures will be displayed after a few minutes of driving** message.

- ▶ Press the  button. The **Use current pressures as new reference values** message appears in the multifunction display.

If you wish to confirm the restart:

- ▶ Press the  button. The **Tyre press. monitor restarted** message appears in the multifunction display.

After you have driven for a few minutes, the system checks whether the current tyre pressures are within the specified range. The new tyre pressures are then accepted as reference values and monitored.

If you wish to cancel the restart:

- ▶ Press the  button. The tyre pressure values stored at the last restart will continue to be monitored.

Radio type approval for the tyre pressure monitor

In certain countries, a radio type approval for the tyre pressure monitor may be required. The radio type approval number for the tyre pressure monitor can be found online at: <http://www.mercedes-benz.de/betriebsanleitung>.

Country	Radio type approval number
Brazil	1489-10-44 15
Dubai	TRA, Registered NO 0016161/08 TRA, Registered NO 0016162/08
Morocco	MR5527 ANRT 2010/ 27. April 2010 MR5526 ANRT 2010/ 27. April 2010
Philippines	ESD-1105558C
Singapore	Compliance with IDA Standard N0140-09
South Africa	TA-2008/1068 TA-2008/1069

Changing a wheel

Flat tyre

You can find information on what to do in the event of a flat tyre in the "Breakdown assistance" section (▷ page 378). Instructions for driving with MOExtended tyres in the event of a flat tyre are also provided there.

Vehicles with an emergency spare

wheel: in the event of a flat tyre, the emergency spare wheel is fitted according to the description under "Fitting a wheel" (▷ page 405).

Interchanging the wheels

WARNING

Interchanging the front and rear wheels may severely impair the driving characteristics if the wheels or tyres have different dimensions. The wheel brakes or suspension components may also be damaged. There is a risk of accident.

Interchange front and rear wheels only if the wheels and tyres are of the same dimensions.

! On vehicles fitted with a tyre pressure monitor, electronic components are located in the wheel.

Tyre-fitting tools should not be applied in the area of the valve, as this could damage the electronic components.

Only have tyres changed at a qualified specialist workshop.

Interchanging the front and rear wheels of differing dimensions can render the general operating permit invalid.

Observe the instructions and safety notes in the "Fitting a wheel" section (▷ page 405).

The wear patterns on the front and rear tyres differ, depending on the operating conditions. Interchange the wheels before a clear wear pattern has formed on the tyres. Front tyres typically wear more on the shoulders and the rear tyres in the centre.

On vehicles that have the same size front and rear wheels, you can interchange the wheels every 5000km to 10,000 km depending on the degree of tyre wear. Maintain the direction of tyre rotation.

Clean the contact surfaces of the wheel and the brake disc thoroughly every time a wheel is interchanged. Check the tyre pressure and, if necessary, restart the tyre pressure loss warning system or the tyre pressure monitor.

Direction of rotation

Tyres with a specified direction of rotation have additional benefits, e.g. if there is a risk of aquaplaning. You will only gain these benefits if the correct direction of rotation is observed.

An arrow on the sidewall of the tyre indicates its correct direction of rotation.

Storing wheels

Store wheels that are not being used in a cool, dry and preferably dark place. Protect the tyres against oil, grease, petrol and diesel.

Cleaning the wheels

WARNING

The water jet of circular-jet nozzles (dirt grinders) can cause damage not visible from the outside to tyres or chassis components. Components damaged in this way can unexpectedly fail. There is a risk of an accident.

Do not use high-pressure cleaners with circular-jet nozzles to clean the vehicle. Have damaged tyres or chassis components replaced immediately.

Fitting a wheel

Preparing the vehicle

- ▶ **Vehicles with an emergency spare wheel:** when fitting the emergency spare wheel in the event of a flat tyre, observe the additional notes on vehicle preparation under "Flat tyre" (▷ page 378).
- ▶ Park the vehicle on firm, non-slippery and level ground.
- ▶ Unload heavy luggage.
- ▶ Engage the electric parking brake manually.
- ▶ Bring the front wheels into the straight-ahead position.
- ▶ Shift the transmission to position **P**.
- ▶ Switch off the engine.
- ▶ **Vehicles without KEYLESS-GO:** remove the key from the ignition lock.
- ▶ **Vehicles with KEYLESS-GO:** open the driver's door. The on-board electronics have status **0**, which is the same as the key having been removed.

- ▶ **Vehicles with KEYLESS-GO:** remove the Start/Stop button from the ignition lock (▷ page 159).
- ▶ If included in the vehicle equipment, take the tyre-change tool kit out of the vehicle.
- ▶ Secure the vehicle to prevent it from rolling away.

i Apart from some country-specific variants, vehicles are not equipped with tyre-changing tools. For more information on which tools are required to perform a wheel change on your vehicle, consult a Mercedes-Benz Service Centre.

Required tyre-changing tools could be, for example:

- jack
- wheel chock
- wheel wrench

Securing the vehicle against rolling away

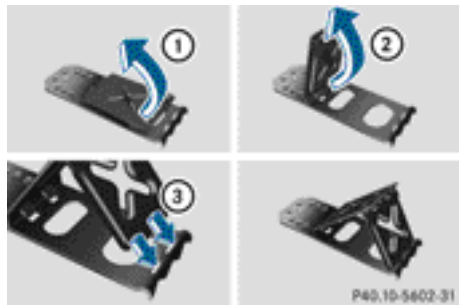

If your vehicle is equipped with a wheel chock, it can be found in the tyre-change tool kit (▷ page 377).

The folding wheel chock is an additional securing measure to prevent the vehicle from rolling away, for example when changing a wheel.

- ▶ Fold both plates upwards ①.
- ▶ Fold out lower plate ②.
- ▶ Guide the lugs on the lower plate fully into the openings in base plate ③.



Securing the vehicle on level ground

- ▶ **On level ground:** place chocks or other suitable items under the front and rear of the wheel that is diagonally opposite the wheel you wish to change.



Securing the vehicle on slight downhill gradients

- ▶ **On light downhill gradients:** place chocks or other suitable items in front of the wheels of the front and rear axle.

Raising the vehicle

WARNING

If you do not position the jack correctly at the appropriate jacking point of the vehicle, the jack could tip over with the vehicle raised. There is a risk of injury.

Only position the jack at the appropriate jacking point of the vehicle. The base of the jack must be positioned vertically, directly under the jacking point of the vehicle.

- ❗ **AMG vehicles equipped with the "Minispare" emergency spare wheel:** Use the "Minispare" emergency spare

wheel **only on the rear axle**. If the "Minispare" emergency spare wheel is mounted on the front axle, it could damage the brake system.

If a tyre on the front axle is faulty, an intact wheel from the rear axle must first be replaced by the "Minispare" emergency spare wheel. The faulty tyre on the front axle should then be replaced by the intact tyre from the rear axle.

Be sure to observe the instruction label on the "Minispare" emergency spare wheel.

The following must be observed when raising the vehicle:

- to raise the vehicle, only use the vehicle-specific jack that has been tested and approved by Mercedes-Benz. If the jack is used incorrectly, it could tip over while the vehicle is raised.
- the jack is designed only to raise and hold the vehicle for a short time while a wheel is being changed. It is not suited for performing maintenance work under the vehicle.
- avoid changing the wheel on uphill and downhill slopes.
- before raising the vehicle, secure it from rolling away by applying the parking brake and inserting wheel chocks. Never disengage the parking brake while the vehicle is raised.
- the jack must be placed on a firm, flat and non-slip surface. On a loose surface, a large, load-bearing underlay must be used. On a slippery surface, a non-slip underlay must be used, e.g. rubber mats.
- do not use wooden blocks or similar objects as a jack underlay. Otherwise, the jack will not be able to achieve its load-bearing capacity due to the restricted height.
- make sure that the distance between the underside of the tyres and the ground does not exceed 3 cm.

- never place your hands or feet under the raised vehicle.
- never lie under the raised vehicle.
- never start the engine when the vehicle is raised.
- never open or close a door or the tailgate when the vehicle is raised.
- make sure that no persons are present in the vehicle when the vehicle is raised.

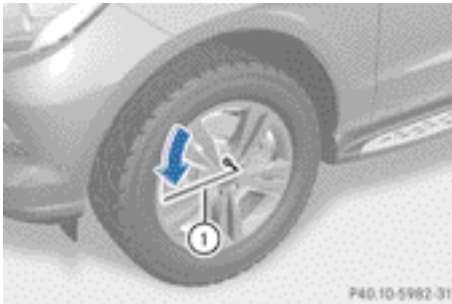

- ▶ Using wheel wrench ①, loosen the bolts on the wheel you wish to change by about one full turn. Do not unscrew the bolts completely.



The jacking points are located just behind the front wheel arches and just in front of the rear wheel arches (arrows).

- ▶ Take the ratchet ring spanner out of the vehicle tool kit and place it on the hexagon nut of the jack so that the letters **AUF** are visible.

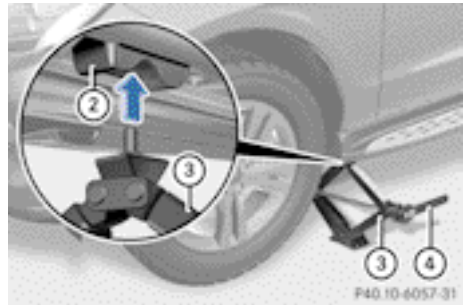

② Jacking points

③ Jack

④ Crank

- ▶ Position jack ③ at jacking point ②.

The centring pin on the jack must be inserted into the intended opening on the jacking point.

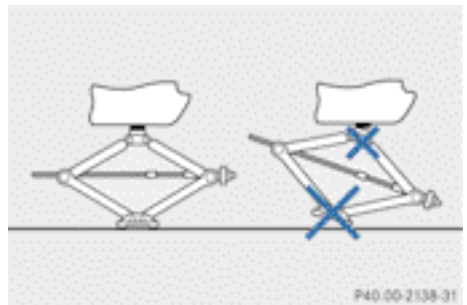

Example

- ▶ Make sure that the base of the jack is positioned vertically under the jacking point.
- ▶ Turn ratchet ring spanner ④ until jack ③ sits completely on jacking point ② and the base of the jack lies evenly on the ground.
- ▶ Turn ratchet ring spanner ④ until the tyre is raised a maximum of three centimetres from the ground.

Removing a wheel

- ⚠ Do not place wheel bolts in sand or dirt. The threads of the wheel bolts and wheel hubs could otherwise be damaged when the bolts are tightened.



- ▶ Unscrew the uppermost wheel bolt completely.
- ▶ Screw centring pin ① into the thread instead of the wheel bolt.
- ▶ Unscrew the remaining wheel bolts fully.
- ▶ Remove the wheel.

Fitting a new wheel

WARNING

Oiled or greased wheel bolts or damaged wheel bolts/hub threads can cause the wheel bolts to come loose. As a result, you could lose a wheel while driving. There is a risk of accident.

Never oil or grease wheel bolts. In the event of damage to the threads, contact a qualified specialist workshop immediately. Have the damaged wheel bolts or hub threads replaced/renewed. Do not continue driving.

WARNING

If you tighten the wheel bolts or wheel nuts when the vehicle is raised, the jack could tip over. There is a risk of injury.

Only tighten the wheel bolts or wheel nuts when the vehicle is on the ground.

Always pay attention to the instructions and safety notices in "Changing a wheel" (▷ page 404).

Only use wheel bolts that have been designed for the wheel and the vehicle. For safety reasons, Mercedes-Benz recommends that you only use wheel bolts which have been

approved for Mercedes-Benz vehicles and the respective wheel.

- ❗ Always use wheel bolts ② to fit the collapsible emergency spare wheel. Using other wheel bolts to fit the collapsible emergency spare wheel could damage the brake system.

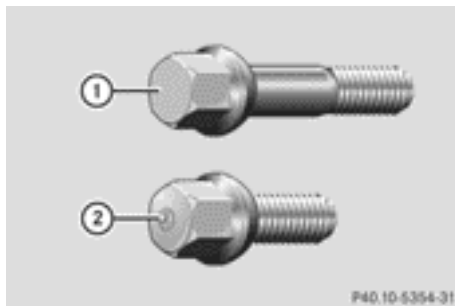

- ① Wheel bolts for all wheels supplied by the factory
- ② Wheel bolts for the "Minispare" emergency spare wheel



- ▶ Clean the wheel and wheel hub contact surfaces.
- ▶ Slide the wheel to be mounted onto the centring pin and push it on.
- ▶ Tighten the wheel bolts until they are finger-tight.
- ▶ Unscrew the centring pin.
- ▶ Tighten the last wheel bolt until it is finger-tight.

Lowering the vehicle

WARNING

The wheels could work loose if the wheel nuts and bolts are not tightened to the specified tightening torque. There is a risk of accident. Have the tightening torque immediately checked at a qualified specialist workshop after a wheel is changed.

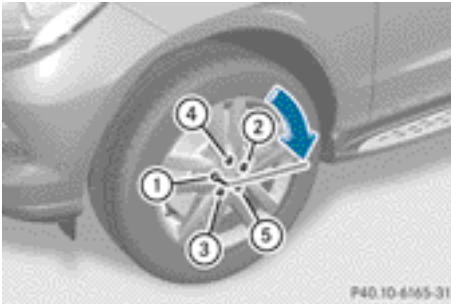

- ▶ Place the ratchet ring spanner onto the hexagon nut of the jack so that the letters **AB** are visible.
- ▶ Turn the ratchet ring spanner until the vehicle is once again standing firmly on the ground.
- ▶ Place the jack to one side.
- ▶ Tighten the wheel bolts evenly in a cross-wise pattern in the sequence indicated (① to ⑤). The tightening torque must be **150 Nm**.
- ▶ Turn the jack back to its initial position.
- ▶ Stow the jack and the rest of the tyre-changing tools in the stowage well under the luggage compartment floor.
- ▶ Check the tyre pressure of the newly fitted wheel and adjust it if necessary. Observe the recommended tyre pressure (▷ page 399).

i Vehicles with tire pressure control system: all fitted wheels must be equipped with functioning sensors.

Wheel and tyre combinations

General notes

! For safety reasons, Mercedes-Benz recommends that you only use tyres and wheels which have been approved by Mercedes-Benz specifically for your vehicle.

These are specially adapted to the control systems, such as ABS or ESP® and are marked as follows:

- MO = Mercedes-Benz Original
- MOE = Mercedes-Benz Original Extended (tyres featuring run-flat characteristics)
- MO1 = Mercedes-Benz Original (only certain AMG tyres)

Mercedes-Benz Original Extended tyres may only be used on wheels that have been specifically approved by Mercedes-Benz.

Only use tyres, wheels or accessories tested and approved by Mercedes-Benz. Certain characteristics, e.g. handling, vehicle noise emissions or fuel consumption, may otherwise be adversely affected. In addition, when driving with a load, tyre dimension variations could cause the tyres to come into contact with the bodywork and axle components. This could result in damage to the tyres or the vehicle.

Mercedes-Benz accepts no liability for damage resulting from the use of tyres, wheels or accessories other than those tested and approved.

Further information about wheels, tyres and approved combinations can be obtained from any qualified specialist workshop.

! Retreaded tyres are neither tested nor recommended by Mercedes-Benz, since previous damage cannot always be detected on retreaded tyres. As a result, Mercedes-Benz cannot guarantee vehicle safety if retreaded tyres are fitted. Do not fit used tyres if you have no information about their previous usage.

! Large wheels: the lower the section width for a certain wheel size, the lower the ride comfort is on poor road surfaces. Roll comfort and suspension comfort are reduced and the risk of damage to the wheels and tyres as a result of driving over obstacles increases.

Overview of abbreviations used in the following tyre tables:

- BA: both axles
- FA: front axle
- RA: rear axle

You will find a table with recommended tyre pressures for various operating conditions on the inside of your vehicle's fuel filler flap. For further information on tyre pressure, see (▷ page 399). Check tyre pressures regularly and only when the tyres are cold.

Notes on the vehicle equipment – always fit the vehicle:

- with tyres of the same size on a given axle (left/right)
- with the same type of tyres at a given time (summer tyres, winter tyres, MOExtended tyres)

Vehicles with MOExtended tyres are not equipped with a TIREFIT kit at the factory. It is therefore recommended that you additionally equip your vehicle with a TIREFIT kit if you fit tyres that do not feature run-flat characteristics, e.g. winter tyres. A TIREFIT kit can be obtained from a qualified specialist workshop.

i Not all wheel/tyre combinations can be mounted at the factory in all countries.

Tyres**GL 350 BlueTEC 4MATIC****Summer tyres****R 19**

Tyres	Light-alloy wheels
BA: 275/55 R 19 111 V ¹	BA: 8.5 J x 19 H2 ET 62

R 20

Tyres	Light-alloy wheels
BA: 275/50 R 20 109 W ¹	BA: 8.5 J x 20 H2 ET 62

R 21

Tyres	Light-alloy wheels
BA: 295/40 ZR 21 111 Y XL ¹	BA: 10.0 J x 21 H2 ET 46

All-weather tyres**R 18**

Tyres	Light-alloy wheels
BA: 265/60 R 18 110 H M+S	BA: 8.0 J x 18 H2 ET 56.5

All-terrain tyres**R 18**

Tyres	Light-alloy wheels
BA: 265/60 R 18 110 H M+S	BA: 8.0 J x 18 H2 ET 56.5

R 19

Tyres	Light-alloy wheels
BA: 275/55 R 19 111 H M+S ¹	BA: 8.5 J x 19 H2 ET 62

Winter tyres**R 18**

Tyres	Light-alloy wheels
BA: 265/60 R 18 110 H M+S 	BA: 8.0 J x 18 H2 ET 56.5

¹ Use of snow chains is not permitted. Observe the notes under "Snow chains".

R 19

Tyres	Light-alloy wheels
BA: 265/55 R 19 109 H M+S 	BA: 8.5 J x 19 H2 ET 62

GL 350 CDI 4MATIC

Summer tyres

R 19

Tyres	Light-alloy wheels
BA: 275/55 R 19 111 V ¹	BA: 8.5 J x 19 H2 ET 62

R 20

Tyres	Light-alloy wheels
BA: 275/50 R 20 109 W ¹	BA: 8.5 J x 20 H2 ET 62

R 21

Tyres	Light-alloy wheels
BA: 295/40 ZR 21 111 Y XL ¹	BA: 10.0 J x 21 H2 ET 46

All-weather tyres

R 18

Tyres	Light-alloy wheels
BA: 265/60 R 18 110 H M+S	BA: 8.0 J x 18 H2 ET 56.5

All-terrain tyres

R 18

Tyres	Light-alloy wheels
BA: 265/60 R 18 110 H M+S	BA: 8.0 J x 18 H2 ET 56.5

R 19

Tyres	Light-alloy wheels
BA: 275/55 R 19 111 H M+S ¹	BA: 8.5 J x 19 H2 ET 62

¹ Use of snow chains is not permitted. Observe the notes under "Snow chains".

Winter tyres**R 18**

Tyres	Light-alloy wheels
BA: 265/60 R 18 110 H M+S 	BA: 8.0 J x 18 H2 ET 56.5

R 19

Tyres	Light-alloy wheels
BA: 265/55 R 19 109 H M+S 	BA: 8.5 J x 19 H2 ET 62

GL 500 4MATIC BlueEFFICIENCY**Summer tyres****R 19**

Tyres	Light-alloy wheels
BA: 275/55 R 19 111 V ¹	BA: 8.5 J x 19 H2 ET 62

R 20

Tyres	Light-alloy wheels
BA: 275/50 R 20 109 W ¹	BA: 8.5 J x 20 H2 ET 62

R 21

Tyres	Light-alloy wheels
BA: 295/40 ZR 21 111 Y XL ¹	BA: 10.0 J x 21 H2 ET 46

All-terrain tyres**R 19**

Tyres	Light-alloy wheels
BA: 275/55 R 19 111 H M+S ¹	BA: 8.5 J x 19 H2 ET 62

Winter tyres**R 19**

Tyres	Light-alloy wheels
BA: 265/55 R 19 109 H M+S 	BA: 8.5 J x 19 H2 ET 62

¹ Use of snow chains is not permitted. Observe the notes under "Snow chains".

GL 63 AMG

Summer tyres

R 21

Tyres	Light-alloy wheels
BA: 295/40 ZR 21 111 Y XL ¹	BA: 10.0 J x 21 H2 ET 46

Winter tyres

R 20

Tyres	Light-alloy wheels
BA: 275/45 R 20 110 V XL M+S 	BA: 9.0 J x 20 H2 ET 41

Emergency spare wheel

Important safety notes

 **WARNING**

The wheel/tyre dimensions and the tyre type of the spare wheel/emergency spare wheel and the wheel to be replaced may differ. Fitting a spare wheel/emergency spare wheel may severely impair the driving characteristics. There is a risk of accident.

To prevent hazardous situations:

- Adapt your driving style accordingly and drive carefully.
- Never fit more than one spare wheel/emergency spare wheel if the dimensions are different to those of the wheel being replaced.
- Only use a spare wheel/emergency spare wheel briefly if the dimensions are different to those of the wheel being replaced.
- Do not switch off ESP®.
- Have the spare wheel/emergency spare wheel in question replaced at the nearest qualified specialist workshop. Make sure that the wheel/tyre dimensions and tyre type are correct.

 **AMG vehicles equipped with the "Minispare" emergency spare wheel:**

Use the "Minispare" emergency spare

wheel **only on the rear axle**. If the "Minispare" emergency spare wheel is mounted on the front axle, it could damage the brake system.

If a tyre on the front axle is faulty, an intact wheel from the rear axle must first be replaced by the "Minispare" emergency spare wheel. The faulty tyre on the front axle should then be replaced by the intact tyre from the rear axle.

Be sure to observe the instruction label on the "Minispare" emergency spare wheel.

When using an emergency spare wheel or spare wheel of a different size, you must not exceed the maximum speed of 80 km/h.

Snow chains must not be fitted to emergency spare wheels.

General notes

Fitting the emergency spare wheel is described in "Fitting a Wheel" (> page 405).

You should regularly check the pressure of the emergency spare wheel, particularly prior to long trips, and correct the pressure as necessary (> page 399). The applicable value is found on the wheel or under "Technical data" (> page 417).

¹ Use of snow chains is not permitted. Observe the notes under "Snow chains".

An emergency spare wheel may also be fitted against the direction of rotation. Observe the time restriction on use as well as the speed limitation specified on the emergency spare wheel.

Replace the tyres after six years at the latest, regardless of wear. This also applies to the emergency spare wheel.

i When you are driving with the collapsible emergency spare wheel fitted, the tyre pressure loss warning system or the tyre pressure monitor cannot function reliably. Only restart the tyre pressure loss warning system/tyre pressure monitor when the defective wheel has been replaced with a new wheel.

Vehicles with tyre pressure monitor:

after mounting an emergency spare wheel, the system may still display the tyre pressure of the removed wheel for a few minutes. The value displayed for the mounted emergency spare wheel is not the same as the current tyre pressure of the emergency spare wheel.

Removing the emergency spare wheel

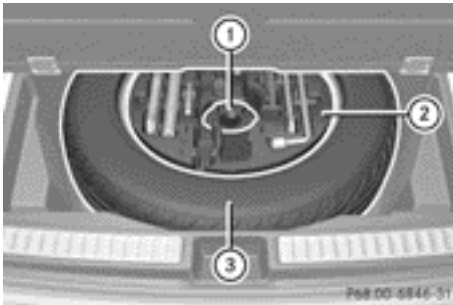

Emergency spare wheel (example: vehicle without lockable luggage compartment floor)

- ① Emergency spare wheel retainer
- ② Stowage tray
- ③ "Minispare" emergency spare wheel

The "Minispare" emergency spare wheel can be found in the stowage well under the luggage compartment floor.

- ▶ Lift the luggage compartment floor up (▷ page 344).
- ▶ **Vehicles with a lockable luggage compartment floor:** remove the stowage tray.
- ▶ Release the Velcro fastener (▷ page 377).
- ▶ Remove the warning triangle and jack.
- ▶ Turn emergency spare wheel retainer ① anti-clockwise and remove it.
- ▶ Remove stowage well ②.
- ▶ Remove "Minispare" emergency spare wheel ③.

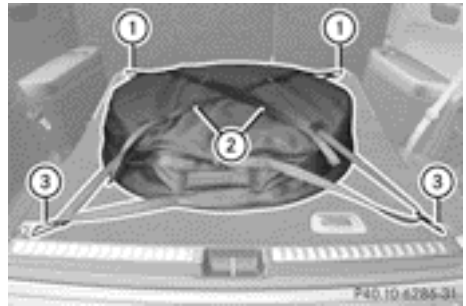

In vehicles with a Bang & Olufsen sound system, the "Minispare" emergency spare wheel is stored in a bag. The bag is secured to the lashing eyelets in the boot.

To stow the "Minispare" emergency spare wheel, the rear seats in the third row must be folded in (▷ page 105).

- ▶ **To remove the emergency spare wheel:** open the tailgate.
- ▶ Loosen tensioning straps ② on both sides.
- ▶ Unhook retaining spring hooks ① and ③ on tensioning straps ② from the lashing eyelets.
- ▶ Remove the bag with the "Minispare" emergency spare wheel.
- ▶ Open the bag and remove the "Minispare" emergency spare wheel.
- ▶ **To stow the emergency spare wheel:** place the "Minispare" emergency spare wheel in the bag and close the bag.
- ▶ Place the bag with the "Minispare" emergency spare wheel in the boot.

- ▶ Hook retaining spring hooks ① and ③ on tensioning straps ② in the lashing eyelets.
- ▶ Tighten tensioning straps ② on both sides.

For further information on changing and fitting a wheel, see (▶ page 405).

Technical data**"Minispare" emergency spare wheel**

Tyres	Light-alloy wheels
T 165/90 R19 119 M	4.5 B x 19 H2 ET 40
Tyre pressure: 420 kPa (4.2 bar/61 psi)	

Useful information	420
Information on technical data	420
Genuine Mercedes-Benz parts	420
Vehicle electronics	421
Identification plates	422
Service products and capacities	423
Vehicle data	431
Trailer tow hitch	432
24 GHz radar sensor system	433

Useful information

- i** This Owner's Manual describes all models, series and optional equipment for your vehicle that were available at the time of going to press. National variations are possible. Note that your vehicle may not be equipped with all of the functions described. This is also the case for systems and functions relevant to safety.
- i** Read the information on qualified specialist workshops: (▷ page 25).

Information on technical data

You can find current technical data on the Internet at:
<http://www.mercedes-benz.com>

- i** The technical data was determined in accordance with EC Directives. All data applies to the vehicle's standard equipment. The data may therefore differ for vehicles with optional equipment. You can obtain further information from a Mercedes-Benz Service Centre.

Genuine Mercedes-Benz parts

WARNING

Driving safety may be impaired if non-approved parts, tyres and wheels or safety-relevant accessories are used.

This could lead to malfunctions in safety-relevant systems, e.g. the brake system. This could cause you to lose control of your vehicle and cause an accident.

For this reason, Mercedes-Benz recommends that you use genuine Mercedes-Benz parts or parts of equal quality. Only use tyres, wheels and accessories that have been specifically approved for your vehicle.

Environmental note

Daimler AG also supplies reconditioned assemblies and parts which are of the same quality as new parts. For these, the same warranty applies as for new parts.

- !** Airbags and seat belt tensioners, as well as control units and sensors for these restraint systems, may be installed in the following areas of your vehicle:

- doors
- door pillars
- door sills
- seats
- dashboard
- instrument cluster
- centre console

Do not install accessories such as audio systems in these areas. Do not carry out repairs or welding. You could impair the operating efficiency of the restraint systems.

Have accessories retrofitted at a qualified specialist workshop.

Mercedes-Benz tests genuine parts and conversion parts and accessories that have been specifically approved for your vehicle for their reliability, safety and suitability. Despite ongoing market research, Mercedes-Benz is unable to assess other parts. Mercedes-Benz accepts no responsibility for the use of parts that have been independently or officially approved.

In Germany, certain parts are only officially approved for installation or modification if they comply with legal requirements. This also applies to some other countries. All genuine Mercedes-Benz parts meet the approval requirements. The use of non-approved parts may invalidate the vehicle's general operating permit.

This is the case:

- if they cause a change of the vehicle type from that for which the vehicle's general operating permit was granted
- if other road users could be endangered
- if the emission or noise levels are adversely affected.

Always specify the vehicle identification number (VIN) (> page 422) and the engine number (> page 423) when ordering genuine Mercedes-Benz parts.

Vehicle electronics

Tampering with the engine electronics

WARNING

Always have work on the engine electronics and related components carried out at a qualified specialist workshop. Otherwise, the vehicle's operating safety could be affected.

- ❗ Only have work carried out on the engine electronics and its associated parts, such as control units, sensors and connector leads, at a qualified specialist workshop. Vehicle components may otherwise wear more quickly and the vehicle's operating permit may be invalidated.

Retrofitting two-way radios and mobile phones (RF transmitters)

WARNING

Incorrect retrofitting of RF transmitters can cause the vehicle electronics to malfunction. The vehicle's operating safety and thus your own safety are impaired.

Have aftermarket radio frequency transmitting equipment installed at a qualified specialist workshop.

WARNING

Incorrect retrofitting of RF transmitters can lead to increased electromagnetic radiation in the vehicle interior. Using an exterior aerial takes into account current scientific discussions relating to the possible health hazards that may result from electromagnetic fields. Have aftermarket radio frequency transmitting equipment installed at a qualified specialist workshop.

- ❗ The operating permit may be invalidated if the instructions for installation and use of RF transmitters are not observed.

In particular, the following conditions must be complied with:

- only approved wavebands may be used.
- the maximum permissible output in these wavebands must be complied with.
- the approved aerial positions must be complied with.

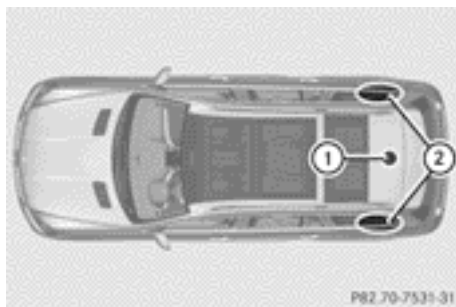

Approved aerial positions

- ① Rear roof area
- ② Rear wing

- ❗ On the rear wing, it is recommended that you position the aerial on the side of the vehicle closest to the centre of the road.

Use Technical Specification ISO/TS 21609 (Road Vehicles – "EMC guidelines for fitting aftermarket radio frequency transmitting equipment") when retrofitting RF (radio frequency) transmitters. Comply with the legal requirements for add-on parts.

If your vehicle has fittings for two-way radio equipment, use the power supply or aerial connections intended for use with the basic wiring. Be sure to observe the manufacturer's additional instructions when installing.

Deviations with respect to wavebands, maximum transmission outputs or aerial positions must be approved by Mercedes-Benz.

The maximum transmission output (PEAK) at the base of the aerial must not exceed the following values:

Waveband	Maximum transmission output
Short wave (f < 54 MHz)	100 W
4 m waveband	30 W
2 m waveband	50 W
Trunked radio/Tetra	35 W
70 cm waveband	35 W
GSM/DCS/PCS 850/900/1800/1900	10 W
UMTS/LTE	10 W

The following can be used in the vehicle without restrictions:

- RF transmitters with a maximum transmission output of up to 100 mW
- mobile phones (GSM/DCS/PCS/UMTS/LTE)

There are no restrictions when positioning the aerial on the outside of the vehicle for the following wavebands:

- Trunked radio/Tetra
- 70 cm waveband
- GSM/DCS/PCS
- UMTS/LTE

Identification plates

Vehicle identification plate with vehicle identification number (VIN)

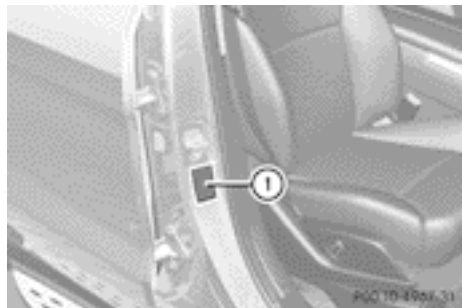

- Open the front right-hand door. You will see vehicle identification plate ①.

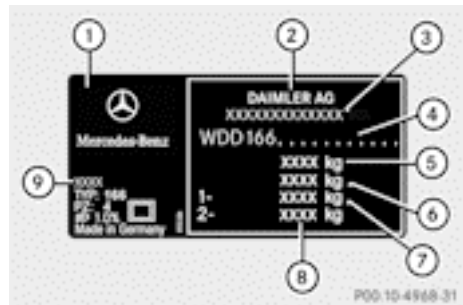

Example: vehicle identification plate

- ① Vehicle identification plate
- ② Vehicle manufacturer (Daimler AG)
- ③ EU type approval number (only for certain countries)
- ④ VIN
- ⑤ Maximum permissible gross vehicle weight (kg)
- ⑥ Maximum permissible mass of vehicle/trailer combination (kg)
- ⑦ Maximum permissible front axle load (kg)
- ⑧ Maximum permissible rear axle load (kg)
- ⑨ Paint code

i The data shown on the vehicle identification plate is example data. This data is different for every vehicle and can deviate from the data shown here. You can find the

data applicable to your vehicle on the vehicle's identification plate.

VIN

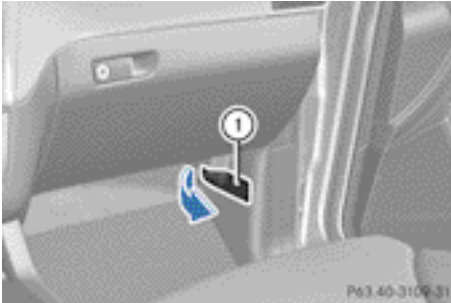

- ▶ Open the front right-hand door.
- ▶ Open cover ① in the direction of the arrow and remove it.
The VIN can be seen.

The VIN can also be found on the vehicle identification plate (▷ page 422).

Engine number

The engine number is stamped onto the crankcase. You can obtain further information from any qualified specialist workshop.

Service products and capacities

Important safety notes

WARNING

When handling, storing and disposing of any service products, please observe the relevant regulations, as you could otherwise endanger yourself and others.

Keep service products away from children.

To protect your health, do not allow service products to come into contact with your eyes or open wounds. See a doctor immediately if any service product is swallowed.

Environmental note

Dispose of service products in an environmentally-responsible manner.

Service products include the following:

- fuels (e.g. petrol, diesel)
- exhaust gas aftertreatment additives, e.g. AdBlue®
- lubricants (e.g. engine oil, transmission oil)
- coolant
- brake fluid
- windscreen washer fluid
- climate control system refrigerant

Components and service products must be matched. Mercedes-Benz recommends that you use products tested and approved by Mercedes-Benz. They are listed in this Mercedes-Benz Owner's Manual in the appropriate section.

You can identify service products approved by Mercedes-Benz by the following inscriptions on the container:

- MB Freigabe (e.g. MB Freigabe 229.51)
- MB Approval (e.g. MB Approval 229.51)

Other designations or recommendations indicate a level of quality or a specification in accordance with an MB Sheet Number (e.g. MB 229.5). They have not necessarily been approved by Mercedes-Benz.

Further information can be obtained from any Mercedes-Benz Service Centre or on the Internet at <http://bevo.mercedes-benz.com>.

Fuel

Important safety notes

WARNING

Fuel is highly flammable. If you handle fuel incorrectly, there is a risk of fire and explosion.

You must avoid fire, naked flames, creating sparks and smoking. Switch off the engine

and, if applicable, the auxiliary heating before refuelling.

WARNING

Fuels are poisonous and hazardous to health. There is a danger of injury.

Do not swallow fuel or let it come into contact with skin, eyes or clothing. Do not inhale fuel vapours. Keep fuels out of the reach of children.

If you or others come into contact with fuel, observe the following:

- Wash the fuel off any affected areas of skin with water and soap immediately.
- If you get fuel in your eyes, rinse them thoroughly with clean water immediately. Seek immediate medical attention.
- If fuel is swallowed, seek immediate medical attention. Do not induce vomiting.
- Change any clothing that has come into contact with fuel immediately.

fuel could result in damage to the fuel system and the engine. The repair costs are high. Notify a qualified specialist workshop and have the fuel tank and fuel lines drained completely.

- ❗ Only refuel using unleaded petrol with at least 95 RON/85 MON that conforms to European standard EN 228 or E DIN 51626-1 or an equivalent specification.

Fuel with this specification may contain up to 10 % ethanol.

- ❗ Do not use the following:

- E85 (petrol with 85 % ethanol)
- E100 (100 % ethanol)
- M15 (petrol with 15 % methanol)
- M85 (petrol with 85 % methanol)
- M100 (100 % methanol)
- Petrol with metallic additives
- Diesel

Do not mix these fuels with petrol, and do not use any additives. This can otherwise lead to engine damage. This does not include cleaning additives for the removal and prevention of residue build-up. Only cleaning additives recommended by Mercedes-Benz should be added to petrol, see "Additives". You can obtain further information from any Mercedes-Benz Service Centre.

Usually you will find information about the fuel grade on the pump. If you cannot find the label on the petrol pump, ask the filling station staff.

- ❗ E10 fuel contains up to 10% bioethanol. Your vehicle is suitable for use with E10 fuel. You can refuel your vehicle using E10 fuel.

- ❗ As a temporary measure, if the recommended fuel is not available, you may also use unleaded petrol with an octane rating of 91 RON/82 MON. This may reduce engine performance and increase fuel consumption. Avoid driving at full throttle.

Tank capacity

Model	Total capacity
All models	100.0 l

Model	Of which reserve fuel
All models	Approx. 12.0 l
GL 63 AMG	Approx. 14.0 l

Petrol (EN 228, E DIN 51626-1)

Fuel grade

- ❗ Do not use diesel to refuel vehicles with a petrol engine. Do not switch on the ignition if you accidentally refuel with the wrong fuel. Otherwise, the fuel will enter the fuel system. Even small amounts of the wrong

Information on refuelling (▷ page 175).

AMG vehicles

! Only refuel using super unleaded petrol with at least 98 RON/88 MON that conforms to European standard EN 228 or an equivalent specification.

You can otherwise impair engine output or damage the engine.

! Premium-grade unleaded petrol with an octane rating of 95 RON/85 MON may be used as a temporary measure if the recommended fuel is not available. This may reduce engine performance and increase fuel consumption. As much as possible, avoid driving at full throttle.

! Regular unleaded petrol with an octane rating of 91 RON/82.5 MON may also be used as a temporary measure if the recommended fuel is not available.

Doing so results in noticeably higher fuel consumption, and the engine power output is noticeably reduced. Avoid driving at full throttle.

If only regular unleaded petrol with an octane rating of 91 RON/82.5 MON or lower is available, you must have the vehicle adapted to this fuel at a qualified specialist workshop.

i E10 fuel contains up to 10% bioethanol. Your vehicle is suitable for use with E10 fuel. You can refuel your vehicle using E10 fuel.

Additives

! Operating the engine with fuel additives can cause wear in the fuel high-pressure pump and contaminate the entire fuel system. The repair costs are high. This does not include additives for the removal and prevention of residue build-up. Petrol must only be mixed with additives recommended by Mercedes-Benz. More information about recommended additives can be obtained from any Mercedes-Benz Service Centre.

One of the major problems with low-grade fuel is the creation of carbon deposits during the process of burning fuel. Mercedes-Benz recommends that you use fuel brands that have additives.

If you use fuels without these additives for a longer period of time, there may be a build-up of carbon deposits. These will form especially on the inlet valves and in the combustion chamber.

This could lead to engine running problems, e.g.:

- longer engine warm-up phase
- uneven idle
- engine noise
- misfiring
- loss of power

In areas where petrol with the required additives is not available, carbon deposits can build up. In this case, Mercedes-Benz recommends the use of additives that have been approved for Mercedes-Benz vehicles; see <http://bevo.mercedes-benz.com>.

The quality of the fuel available in some countries may not be sufficient. Residue could build up as a result. In such cases, and in consultation with a Mercedes-Benz Service Centre, the petrol may be mixed with the additive recommended by Mercedes-Benz (part no. A000989254510). You must observe the notes and mixing ratios specified on the container.

Consult a Mercedes-Benz Service Centre to view a list of approved products. Observe the instructions for use in the product description.

Do not mix other fuel additives with fuel. This causes unnecessary costs and could damage the engine.

Diesel (EN 590)

Fuel grade

WARNING

If you mix diesel fuel with petrol, the flash point of this fuel mixture is lower than that of pure diesel fuel. When the engine is running, components in the exhaust system may overheat unnoticed. There is a risk of fire.

Never refuel with petrol. Never add petrol to diesel fuel.

! When refuelling, only use diesel fuel that conforms to the European standard EN 590 or is of equivalent quality. Fuel that does not conform to EN 590 can lead to increased wear as well as damage to the engine and exhaust system.

! Do not use the following:

- marine diesel
- heating oil
- bio-diesel
- vegetable oil
- petrol
- paraffin
- kerosene

Do not mix such fuels with diesel fuel and do not use any special additives. This can otherwise lead to engine damage. This does not include flow improver additives. For further information, see "Flow improvers".

! **Vehicles with a diesel particle filter:** in countries outside the EU, only refuel with low-sulphur Euro diesel with a sulphur content under 50 ppm; otherwise the emission control system could be damaged.

! **Vehicles without a diesel particle filter:** in countries where only diesel fuel with a high sulphur content is available, you will need to carry out your vehicle's oil change at shorter intervals. More information about the interval for oil change can be

obtained from any qualified specialist workshop.

Usually you will find information about the fuel grade on the pump. If you cannot find the label on the petrol pump, ask the filling station staff.

Information on refuelling (▷ page 175).

Low outside temperatures

In winter months, diesel fuel with an improved cold flow quality is available. In Europe, the EN 590 standard defines various climate-dependent temperature categories. Malfunctions can be avoided by refuelling with diesel fuel that corresponds to the climatic specifications outlined in EN 590. At unusually low outside temperatures, it is possible that the flow characteristics of the diesel fuel could be insufficient. Accordingly, diesel fuel from warmer areas may not be suitable for operation in colder climatic conditions.

i Further information on country-specific fuel properties can be obtained from oil companies, e.g. at filling stations.

Flow improvers

To improve the low-temperature resistance of diesel fuel, a flow improver can be attached. The effectiveness of a flow improver is not guaranteed for every fuel.

Only use flow improvers tested and approved by Mercedes-Benz. During use, please observe the information on operation.

Correct dosage and sufficient mixing are decisive in improving low-temperature resistance with the flow improver. Overdosage can potentially even decrease low-temperature resistance and must therefore be avoided. Follow the manufacturer's guidelines on dosage.

Mix the additive into the diesel in good time, before the flow characteristics of the diesel become insufficient. Otherwise, malfunctions can only be rectified by heating the entire fuel system, e.g. by parking in a heated garage.

More information about recommended flow improvers can be obtained from any qualified specialist workshop.

Fuel consumption information



Environmental note

CO₂ (carbon dioxide) is the gas which scientists believe to be principally responsible for global warming (the greenhouse effect). Your vehicle's CO₂ emissions are directly related to fuel consumption and therefore depend on:

- efficient use of the fuel by the engine
- driving style
- other non-technical factors, such as environmental influences or road conditions

You can minimise your vehicle's CO₂ emissions by driving carefully and having it serviced regularly.

The vehicle will use more fuel than usual in the following situations:

- at very low outside temperatures
- in urban traffic
- on short journeys
- in mountainous terrain
- when towing a trailer

- i** Only for certain countries: you can find the current consumption and emission values of your vehicle in the COC documents (EU CERTIFICATE OF CONFORMITY). These documents are delivered with your vehicle. The consumption figures were in each case based on the currently applicable version:
- for vehicles that comply with standards up to and including the EURO 4 standard, in accordance with EU Directive 80/1268/EEC
 - for vehicles that comply with or exceed the EURO 5 standard, in accordance with Regulation (EC) No. 715/2007

Deviations from these values may occur under normal operating conditions.

AdBlue®

Important safety notes

AdBlue® is a water-soluble fluid for the exhaust gas aftertreatment of diesel engines. It is:

- not poisonous
- colourless and odourless
- not flammable

When you open the AdBlue® container, small amounts of ammonia vapour may be released.

Ammonia vapours have a pungent odour and are particularly irritating to the skin, to mucous membranes and to the eyes. You may experience a burning sensation in your eyes, nose and throat. Coughing and watering of the eyes are possible.

Do not inhale any ammonia vapours that may be released. Fill the AdBlue® tank only in well-ventilated areas.

Low outside temperatures

AdBlue® freezes at a temperature of approximately -11 °C. The vehicle is equipped with an AdBlue® preheating system at the factory. Winter operation can therefore be guaranteed even at temperatures below -11 °C.

Additives

- !** Only use AdBlue® in accordance with ISO 22241. Do not use additives with AdBlue® and do not dilute AdBlue® with water. This may destroy the BlueTEC exhaust gas aftertreatment system.

Purity

- !** Impurities in AdBlue® (e.g. due to other service products, cleaning agents or dust) lead to:

- increased emission values
- damage to the catalytic converter

- engine damage
- malfunctions in the BlueTEC® exhaust gas aftertreatment system

Assuring the purity of AdBlue® is particularly important with respect to avoiding malfunctions in the BlueTEC exhaust gas aftertreatment system.

If AdBlue® is pumped out of the AdBlue® tank, e.g. during repair work, do not use this fluid to refill the tank. The purity of the fluid can no longer be guaranteed.

Capacities

Model	Total capacity
GL 350 Blue-TEC 4MATIC	31.2 l

Engine oil

General notes

The quality of the engine oil is decisive for the function and service life of an engine. After extensive tests, Mercedes-Benz approves engine oils that correspond to the current technical standard.

Therefore, only Mercedes-Benz approved engine oils may be used in Mercedes-Benz engines.

Further information on tested and approved engine oils can be obtained from any Mercedes-Benz Service Centre. Mercedes-Benz recommends that you have the oil change carried out at a qualified specialist workshop. Mercedes-Benz approval is indicated on the oil container by the inscription "MB Approval" and the corresponding designation, e.g. MB Approval 229.51.

You can call up an overview of approved engine oils on the Internet at: <http://bevo.mercedes-benz.com> by entering the designation, e.g. 229.5.

The table shows which engine oils have been approved for your vehicle.

Petrol engines	MB Approval
GL 500 4MATIC Blue-EFFICIENCY	229.5
GL 63 AMG	

Diesel engines with a diesel particle filter	MB Approval
GL 350 Blue-TEC 4MATIC	228.51, 229.31, 229.51
GL 350 CDI 4MATIC	

Diesel engines without a diesel particle filter	MB Approval
GL 350 CDI 4MATIC	228.31, 228.5, 228.51, 229.3, 229.31, 229.5, 229.51

Use only SAE 0W-40 or SAE 5W-40 engine oils for AMG vehicles.

i If the engine oils listed in the table are not available, you may add the following engine oils until the next oil change:

- vehicles with a petrol engine: MB Approval 229.1 229.3 or ACEA A3
- diesel engines: MB Approval 229.1, 229.3, 229.5 or ACEA C3

Use only SAE 0W-40 or SAE 5W-40 engine oils for AMG vehicles.

This may only be topped up once, and the quantity must not be greater than 1.0 l.

Capacities

The following values refer to an oil change including the oil filter.

Model	Replacement amount
GL 500 4MATIC BlueEFFICIENCY	8.5 l
GL 63 AMG	With external oil cooler: 9.5 l
GL 350 Blue-TEC 4MATIC GL 350 CDI 4MATIC	8.0 l

Additives

! Do not use any additives with the engine oil. This could damage the engine.

Engine oil viscosity

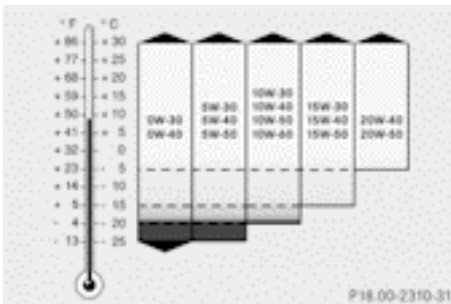

Viscosity describes the flow characteristics of a fluid. If an engine oil has a high viscosity rating, it flows slowly; the lower the viscosity, the faster it flows.

Engine oil selection is based on the respective outside temperatures and in accordance with the SAE classification (viscosity). The table shows you which SAE classifications are to be used. The low-temperature properties of engine oils can be significantly impaired during operation due to, for example, ageing or soot and fuel accretion. It is therefore strongly recommended to observe regular oil changes using an approved engine oil with the appropriate SAE classification.

Brake fluid

⚠ WARNING

Over a period of time, the brake fluid absorbs moisture from the air; This lowers its boiling point.

If the boiling point of the brake fluid is too low, vapour pockets may form in the brake system when the brakes are applied hard (e.g. when driving downhill). This impairs braking efficiency.

You should have the brake fluid renewed at regular intervals. The brake fluid change intervals can be found in the Service Booklet.

Only use brake fluid approved by Mercedes-Benz according to MB Approval 331.0.

Information about approved brake fluid can be obtained at any qualified specialist workshop or on the Internet at <http://bevo.mercedes-benz.com>.

i Have the brake fluid renewed regularly at a qualified specialist workshop.

Coolant

Important safety notes

⚠ WARNING

Antifreeze is highly flammable. Fire, naked flames and smoking are prohibited when handling antifreeze.

If antifreeze comes into contact with hot engine parts, it may ignite and you could burn yourself. Do not spill any antifreeze on hot engine parts.

! Only add coolant that has been premixed with the desired antifreeze protection. You could otherwise damage the engine.

Further information on coolants can be found in the Mercedes-Benz Specifications for Service Products, MB Specifications for Service Products 310.1, e.g. on the Internet at <http://bevo.mercedes-benz.com>. Or contact a qualified specialist workshop.

! Always use a suitable coolant mixture, even in countries where high temperatures prevail.

Otherwise, the engine cooling system is not sufficiently protected from corrosion and overheating.

! The engine cooling system is filled with coolant, which must be renewed after 15 years or after 250,000 kilometres at the latest.

The coolant is a mixture of water and anti-freeze/corrosion inhibitor. It performs the following tasks:

- anti-corrosion protection
- antifreeze protection
- raising the boiling point

If antifreeze/corrosion inhibitor is present in the correct concentration, the boiling point of the coolant during operation will be approximately 130 °C.

The antifreeze/corrosion inhibitor concentration in the engine cooling system should:

- be at least 50%. This will protect the engine cooling system against freezing down to approximately -37 °C.
- not exceed 55% (antifreeze protection down to -45 °C). Heat will otherwise not be dissipated as effectively.

If the vehicle has lost coolant, top it up with equal amounts of water and antifreeze/corrosion inhibitor. Mercedes-Benz recommends an antifreeze/corrosion inhibitor concentrate in accordance with MB Specifications for Service Products 310.1.

The coolant is checked at every maintenance interval at a qualified specialist workshop.

i When the vehicle is first delivered, it is filled with a coolant mixture that ensures adequate antifreeze and corrosion protection.

Windscreen washer system and headlamp cleaning system

Important safety notes

WARNING

Windscreen washer concentrate is highly flammable. If it comes into contact with hot engine components or the exhaust system it could ignite. There is a risk of fire and injury. Make sure that no windscreen washer concentrate is spilled next to the filler neck.

- !** Only use washer fluid that is suitable for plastic lamp lenses, e.g. MB SummerFit or MB WinterFit. Unsuitable washer fluid could damage the plastic lenses of the headlamps.
- !** Do not use distilled or de-ionised water in the washer fluid reservoir. Otherwise, the level sensor may be damaged.
- !** Only the washer fluids SummerFit and WinterFit can be mixed. Otherwise, the spraying nozzles could become blocked.

At temperatures above freezing:

- ▶ Fill the washer fluid reservoir with a mixture of water and washer fluid, e.g. MB SummerFit.

Mix 1 part MB SummerFit to 100 parts water.

At temperatures below freezing:

- ▶ Fill the washer fluid reservoir with a mixture of water and washer fluid, e.g. MB WinterFit.

Adapt the mixing ratio to the outside temperature.

- Down to -10 °C: mix 1 part MB WinterFit to 2 parts water.
- Down to -20 °C: mix 1 part MB WinterFit to 1 part water.
- Down to -29 °C: mix 2 parts MB WinterFit to 1 part water.

i Add washer fluid concentrate, e.g. MB SummerFit or MB WinterFit, to the washer fluid all year round.

Vehicle data

General notes

Please note that for the specified vehicle data:

- the heights specified may vary as a result of:
 - tyres
 - load
 - condition of the suspension
 - optional equipment
- items of optional equipment increase the unladen weight and reduce the maximum payload. The unladen weight is specified in accordance with EC directive and includes:
 - driver (68 kg)
 - luggage (7 kg)
 - all fluids (fuel tank 90% full)
- vehicle-specific weight information can be found on the vehicle identification plate (▷ page 422).
- only for certain countries: you can find vehicle-specific vehicle data in the COC documents (CERTIFICATE OF CONFORMITY). These documents are delivered with your vehicle.

Dimensions and weights

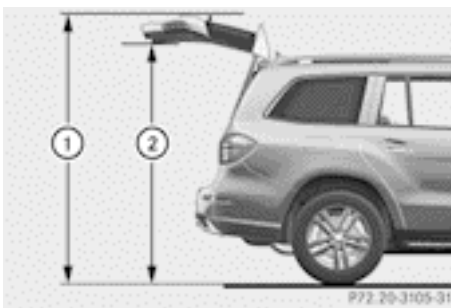

	① Opening height	② Maximum headroom
Models without ON&OFF-ROAD package	2132 mm – 2207 mm	1934 mm – 2009 mm
Models with ON&OFF-ROAD package	2132 mm – 2237 mm	1934 mm – 2039 mm
AMG vehicles	2146 mm – 2200 mm	1949 mm – 2002 mm

Missing values were not available at the time of going to print.

All models (except AMG vehicles)	
Vehicle length	5 120 mm
Vehicle width including exterior mirrors	2 141 mm
Vehicle width excluding exterior mirrors	1 934 mm
Maximum vehicle height	1 910 mm
Maximum vehicle height (ON&OFFROAD package)	1 940 mm
Minimum vehicle height (highway driving level)	1 850 mm
Wheelbase	3 075 mm
Maximum ground clearance	276 mm
Maximum ground clearance (ON&OFFROAD package)	306 mm
Minimum ground clearance	201 mm

All models (except AMG vehicles)

Unladen weight

Maximum roof load 100 kg

GL 63 AMG

Vehicle length 5146 mm

Vehicle width including exterior mirrors 2141 mm

Vehicle width excluding exterior mirrors 1982 mm

Maximum vehicle height 1903 mm

Minimum vehicle height 1850 mm

Wheelbase 3075 mm

Maximum ground clearance 249 mm

Minimum ground clearance 198 mm

Unladen weight 2580 kg

Maximum roof load 100 kg

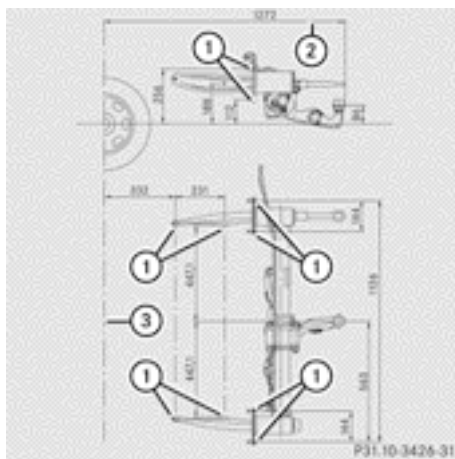

Example: anchorage points for the trailer tow hitch

- ① Anchorage points
- ② Overhang dimension
- ③ Rear axle centre line

For trailer tow hitches fitted at the factory, the overhang dimension including protective covering is 1,272mm.

Trailer tow hitch

Mounting dimensions

! If you have a trailer tow hitch retrofitted, changes to the cooling system and drive train may be necessary, depending on the vehicle type.

If you have a trailer tow hitch retrofitted, observe the anchorage points on the chassis frame.

Trailer loads	
	All models (except AMG vehicles)
Permissible trailer load, unbraked	750 kg
Permissible trailer load, braked (at a minimum gradient-climbing capability of 12 % from a standstill)	3500 kg
Maximum drawbar noseweight (the drawbar nose-weight is not included in the trailer load)	140 kg
Permissible rear axle load when towing a trailer	1900 kg

	AMG vehicles
Permissible trailer load, unbraked	750 kg
Permissible trailer load, braked (at a minimum gradient-climbing capability of 12 % from a standstill)	3050 kg
Maximum drawbar noseweight (the drawbar nose-weight is not included in the trailer load)	140 kg
Permissible rear axle load when towing a trailer	1750 kg

24 GHz radar sensor system

The 24 GHz radar sensor system requires separate approval for each country. If you are driving in a country in which the radar sensor system is not approved, you must deactivate the system using the on-board computer (▷ page 283).

The current country overview can be obtained from a Mercedes-Benz Service Centre or in the Internet under: <http://www.mercedes-benz.de/betriebsanleitung>.

Vehicles with a navigation system: the radar sensor system is deactivated automatically near radio telescope facilities. A display message appears in the multifunction display to tell you that the radar sensor system is being switched off (▷ page 310).

The currently active systems are automatically deactivated:

- DISTRONIC PLUS (▷ page 198)
- Blind Spot Assist (▷ page 238)
- Active Blind Spot Assist (▷ page 242)
- BAS PLUS (▷ page 62)
- PRE-SAFE® Brake (▷ page 68)

If the deactivation does not occur automatically, you must deactivate the radar sensor system using the on-board computer (▷ page 283).

Vehicles without navigation and vehicles for Australia: you must deactivate the radar sensor system using the on-board computer when you are near a radio telescope facility (▷ page 283).

Publication details

Internet

Further information about Mercedes-Benz vehicles and about Daimler AG can be found on the following websites:

<http://www.mercedes-benz.com>

<http://www.daimler.com>

Editorial office

You are welcome to forward any queries or suggestions you may have regarding this Owner's Manual to the technical documentation team at the following address:

Daimler AG, HPC: CAC, Customer Service,
70546 Stuttgart, Germany

©Daimler AG: Not to be reprinted, translated or otherwise reproduced, in whole or in part, without written permission of Daimler AG.

As at 25.01.2012

Nur für internen Gebrauch / For internal use only



1665840781Z102

Order no. 6515 0428 02 Part no. 166 584 07 81 Z102 Edition NA 2012-11b

Nur für internen Gebrauch / For internal use only